



2N7304D, 2N7304R 2N7304H

REGISTRATION PENDING
Currently Available as FRE264 (D, R, H)
 January 1994

**Radiation Hardened
 N-Channel Power MOSFETs**

Features

- 23A, 250V, RDS(on) = 0.130Ω
- Second Generation Rad Hard MOSFET Results From New Design Concepts
- Gamma
 - Meets Pre-Rad Specifications to 100KRAD(Si)
 - Defined End Point Specs at 300KRAD(Si) and 1000KRAD(Si)
 - Performance Permits Limited Use to 3000KRAD(Si)
- Gamma Dot
 - Survives 3E9RAD(Si)/sec at 80% BVDS Typically
 - Survives 2E12 Typically If Current Limited to IDM
- Photo Current
 - 22.0nA Per-RAD(Si)/sec Typically
- Neutron
 - Pre-RAD Specifications for 1E13 Neutrons/cm²
 - Usable to 1E14 Neutrons/cm²
- Single Event
 - Typically Survives 1E5ions/cm² Having an LET ≤ 35MeV/mg/cm² and a Range ≥ 30μm at 80% BVDS

Description

The Harris Semiconductor Sector has designed a series of SECOND GENERATION hardened power MOSFETs of both N and P channel enhancement types with ratings from 100V to 500V, 1A to 60A, and on resistance as low as 25mΩ. Total dose hardness is offered at 100KRAD(Si) and 1000KRAD(Si) with neutron hardness ranging from 1E13n/cm² for 500V product to 1E14n/cm² for 100V product. Dose rate hardness (GAMMA DOT) exists for rates to 1E9 without current limiting and 2E12 with current limiting. Heavy ion survival from signal event drain burn-out exists for linear energy transfer (LET) of 35 at 80% of rated voltage.

This MOSFET is an enhancement-mode silicon-gate power field effect transistor of the vertical DMOS (VDMOS) structure. It is specially designed and processed to exhibit minimal characteristic changes to total dose (GAMMA) and neutron (n⁰) exposures. Design and processing efforts are also directed to enhance survival to heavy ion (SEE) and/or dose rate (GAMMA DOT) exposure.

This part may be supplied as a die or in various packages other than shown above. Reliability screening is available as either non TX (commercial), TX equivalent of MIL-S-19500, TXV equivalent of MIL-S-19500, or space equivalent of MIL-S-19500. Contact the Harris Semiconductor High-Reliability Marketing group for any desired deviations from the data sheet.

Package

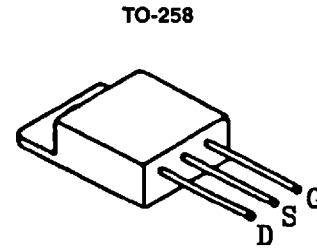

Symbol

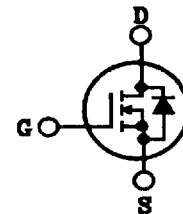

Absolute Maximum Ratings (TC = +25°C) Unless Otherwise Specified

	2N7304D, R, H	UNITS
Drain-Source Voltage.....	VDS 250	V
Drain-Gate Voltage (RGS = 20kΩ).....	VDGR 250	V
Continuous Drain Current		
TC = +25°C.....	ID 23	A
TC = +100°C.....	ID 15	A
Pulsed Drain Current.....	IDM 69	A
Gate-Source Voltage.....	VGS ±20	V
Maximum Power Dissipation		
TC = +25°C.....	PT 150	W
TC = +100°C.....	PT 60	W
Derated Above +25°C.....	1.20	W/°C
Inductive Current, Clamped, L = 100μH, (See Test Figure).....	ILM 69	A
Continuous Source Current (Body Diode).....	IS 23	A
Pulsed Source Current (Body Diode).....	ISM 69	A
Operating And Storage Temperature.....	TJC, TSTG -55 to +150	°C
Lead Temperature (During Soldering)		
Distance > 0.063 in. (1.6mm) From Case, 10s Max.....	TL 300	°C

CAUTION: These devices are sensitive to electrostatic discharge. Users should follow proper I.C. Handling Procedures.
 Copyright © Harris Corporation 1994

Specifications 2N7304D, 2N7304R, 2N7304H - Registration Pending

Pre-Radiation Electrical Specifications TC = +25°C, Unless Otherwise Specified

PARAMETER	SYMBOL	TEST CONDITIONS	LIMITS		UNITS	
			MIN	MAX		
Drain-Source Breakdown Volts	BVDSS	VGS = 0, ID = 1mA	250	-	V	
Gate-Threshold Volts	VGS(th)	VDS = VGS, ID = 1mA	2.0	4.0	V	
Gate-Body Leakage Forward	IGSSF	VGS = +20V	-	100	nA	
Gate-Body Leakage Reverse	IGSSR	VGS = -20V	-	100	nA	
Zero-Gate Voltage Drain Current	IDSS1	VDS = 250V, VGS = 0	-	1	mA	
	IDSS2	VDS = 200V, VGS = 0	-	0.025		
	IDSS3	VDS = 200V, VGS = 0, TC = +125°C	-	0.25		
Rated Avalanche Current	IAR	Time = 20µs	-	69	A	
Drain-Source On-State Volts	VDS(on)	VGS = 10V, ID = 23A	-	3.14	V	
Drain-Source On Resistance	RDS(on)	VGS = 10V, ID = 15A	-	0.130	W	
Turn-On Delay Time	td(on)	VDD = 125V, ID = 23A Pulse Width = 3µs Period = 300µs RG = 10Ω 0 ≤ VGS ≤ 10 (See Test Circuit)	-	84	ns	
Rise Time	tr		-	158		
Turn-Off Delay Time	td(off)		-	544		
Fall Time	tf		-	134		
Gate-Charge Threshold	QG(th)	VDD = 125V, ID = 23A IGS1 = IGS2 0 ≤ VGS ≤ 20	5	22	nc	
Gate-Charge On State	QG(on)		103	412		
Gate-Charge Total	QGM		200	800		
Plateau Voltage	VGP		3	12		V
Gate-Charge Source	QGS		20	80		nc
Gate-Charge Drain	QGD		50	200		
Diode Forward Voltage	VSD	ID = 23A, VGD = 0	0.6	1.8	V	
Reverse Recovery Time	TT	I = 23A; di/dt = 100A/µs	-	2000	ns	
Junction-To-Case	Rθjc		-	0.83	°C/W	
Junction-To-Ambient	Rθja	Free Air Operation	-	48		

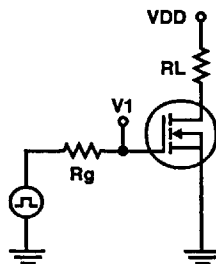

FIGURE 1. SWITCHING TIME TESTING

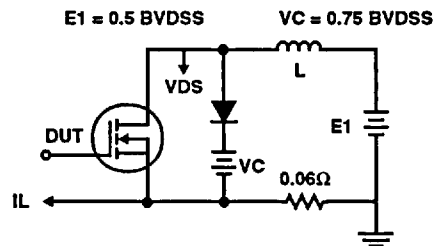

FIGURE 2. CLAMPED INDUCTIVE SWITCHING, ILM

Specifications 2N7304D, 2N7304R, 2N7304H - Registration Pending**Post-Radiation Electrical Specifications TC = +25°C, Unless Otherwise Specified**

PARAMETER	SYMBOL	TYPE	TEST CONDITIONS	LIMITS		UNITS	
				MIN	MAX		
Drain-Source Breakdown Volts	(Note 4, 6)	BVDSS	2N7304D, R	VGS = 0, ID = 1mA	250	-	V
	(Note 5, 6)	BVDSS	2N7304H	VGS = 0, ID = 1mA	238	-	V
Gate-Source Threshold Volts	(Note 4, 6)	VGS(th)	2N7304D, R	VGS = VDS, ID = 1mA	2.0	4.0	V
	(Note 3, 5, 6)	VGS(th)	2N7304H	VGS = VDS, ID = 1mA	1.5	4.5	V
Gate-Body Leakage Forward	(Note 4, 6)	IGSSF	2N7304D, R	VGS = 20V, VDS = 0	-	100	nA
	(Note 5, 6)	IGSSF	2N7304H	VGS = 20V, VDS = 0	-	200	nA
Gate-Body Leakage Reverse	(Note 2, 4, 6)	IGSSR	2N7304D, R	VGS = -20V, VDS = 0	-	100	nA
	(Note 2, 5, 6)	IGSSR	2N7304H	VGS = -20V, VDS = 0	-	200	nA
Zero-Gate Voltage Drain Current	(Note 4, 6)	IDSS	2N7304D, R	VGS = 0, VDS = 200V	-	25	μA
	(Note 5, 6)	IDSS	2N7304H	VGS = 0, VDS = 200V	-	100	μA
Drain-Source On-State Volts	(Note 1, 4, 6)	VDS(on)	2N7304D, R	VGS = 10V, ID = 23A	-	3.14	V
	(Note 1, 5, 6)	VDS(on)	2N7304H	VGS = 16V, ID = 23A	-	4.71	V
Drain-Source On Resistance	(Note 1, 4, 6)	RDS(on)	2N7304D, R	VGS = 10V, ID = 15A	-	.130	Ω
	(Note 1, 5, 6)	RDS(on)	2N7304H	VGS = 14V, ID = 15A	-	.195	Ω

NOTES:

1. Pulse test, 300μs max
2. Absolute value
3. Gamma = 300KRAD(Si)
4. Gamma = 10KRAD(Si) for "D", 100KRAD(Si) for "R" Neutron = 1E13
5. Gamma = 1000KRAD(Si) Neutron = 1E13
6. Insitu Gamma bias must be sampled for both VGS = +10V, VDS = 0V and VGS = 0V, VDS = 80% BVDSS
7. Gamma data taken 6/15/90 on TA 17663 devices by GE ASTRO SPACE; EMC/SURVIVABILITY LABORATORY; KING OF PRUSSIA, PA 19401
8. Single event drain burnout testing by Titus, J.L., et al of NWSC, Crane, IN at Brookhaven Nat. Lab. Dec 11-14, 1989
9. Neutron derivation, HARRIS Application Note AN-8831, Oct. 1988

2N7304D, 2N7304R, 2N7304H - Registration Pending

Typical Performance Characteristics

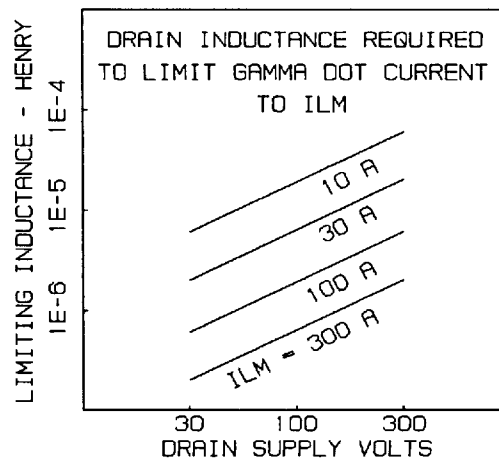
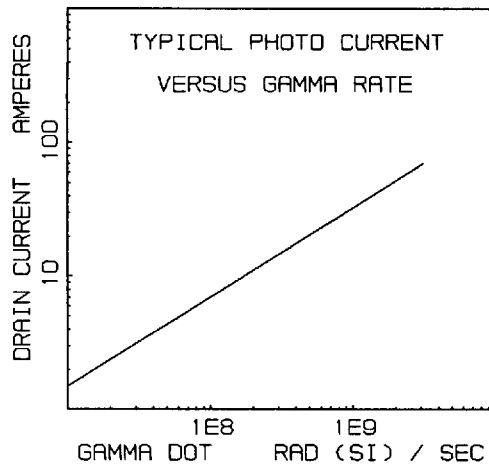
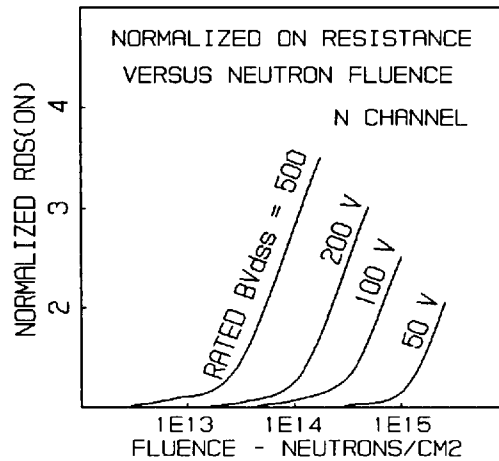
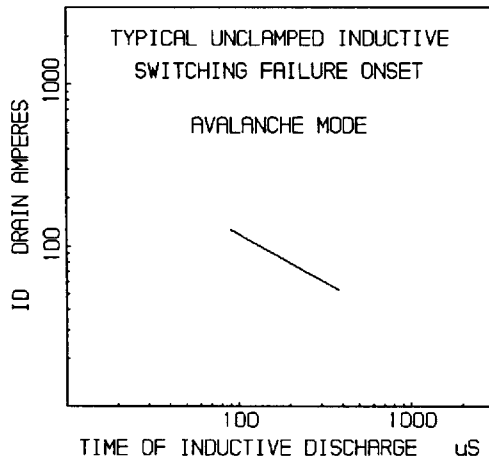
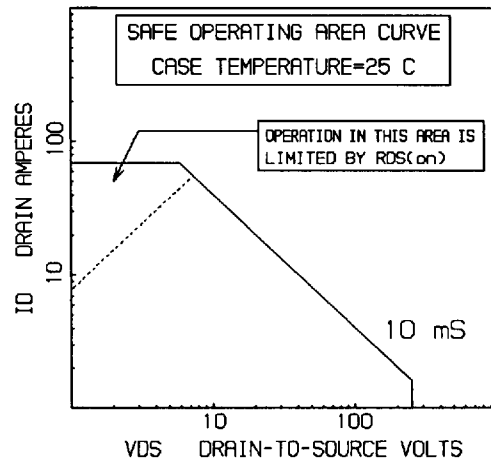
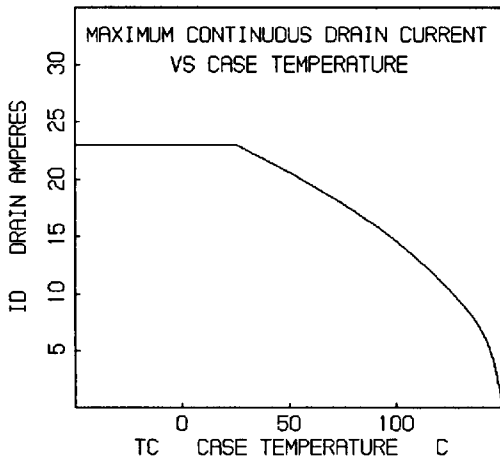

2N7304D, 2N7304R, 2N7304H - Registration Pending

Packaging

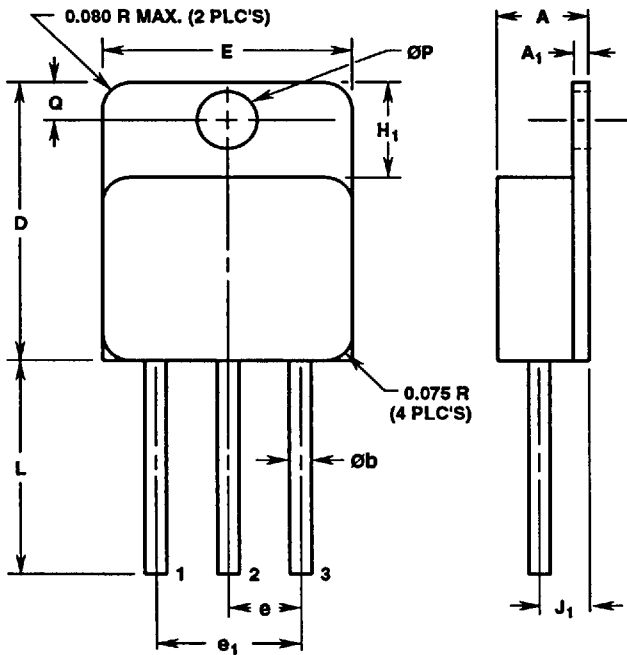

TO-258AA
3 LEAD JEDEC TO-258AA HERMETIC METAL PACKAGE

SYMBOL	INCHES		MILLIMETERS		NOTES
	MIN	MAX	MIN	MAX	
A	0.250	0.270	6.35	6.85	-
A ₁	0.035	0.045	0.89	1.14	-
Øb	0.055	0.065	1.40	1.65	2, 3
D	0.815	0.830	20.71	21.08	-
E	0.685	0.695	17.40	17.65	-
e	0.200 TYP		5.08 TYP		4
e ₁	0.400 BSC		10.16 BSC		4
H ₁	0.270	0.290	6.86	7.36	-
J ₁	0.130	0.150	3.31	3.81	4
L	0.600	0.650	15.24	16.51	-
ØP	0.155	0.165	3.94	4.19	-
Q	0.115	0.125	2.93	3.17	-

NOTES:

1. These dimensions are within allowable dimensions of Rev. A of JEDEC TO-258AA outline dated 2-88.
2. Add typically 0.002 inches (0.05mm) for solder coating.
3. Lead dimension (without solder).
4. Position of lead to be measured 0.250 inches (6.35mm) from bottom of dimension D.
5. Die to base BeO isolated, terminals to case ceramic isolated.
6. Controlling dimension: Inch.
7. Revision 1 dated 1-93.