



TO : General Accounts

DATE : October. 22, 2009.

SAMSUNG TFT-LCD**MODEL NO. : LTN133AT09-G02****NOTE :**

- Extension code [-G] ; LTN133AT09-G02
- Surface type [**Glare**]

APPROVED BY : *SS SEOMUN*PREPARED BY : **Application Engineering Part , Mobile LCD Division****SAMSUNG ELECTRONICS CO., LTD.****Samsung Secret**

CONTENTS

Revision History ----- (3)

General Description ----- (4)

1. Absolute Maximum Ratings ----- (5)

 1.1 Absolute Ratings of environment

 1.2 Electrical Absolute Ratings

2. Optical Characteristics ----- (7)

3. Electrical Characteristics ----- (11)

 3.1 TFT LCD Module

 3.2 Backlight Unit

 3.3 LED Array

 3.4 LED information

4. Block Diagram ----- (14)

 4.1 TFT LCD Module

 4.2 Backlight Unit

5. Input Terminal Pin Assignment ----- (15)

 5.1 Input Signal & Power

 5.2 LVDS Interface

 5.3 Backlight Unit

 5.4 Timing Diagrams of LVDS For Transmitting

 5.5 Input Signals, Basic Display Colors and Gray Scale of Each Color.

 5.6 Pixel format

6. Interface Timing ----- (20)

 6.1 Timing Parameters

 6.2 Timing Diagrams of interface Signal

 6.3 Power ON/OFF Sequence

7. Outline Dimension ----- (22)

8. General Precaution ----- (24)

Samsung Secret

REVISION HISTORY

Approval

Date	Revision No.	Page	Summary
Apr. 27, 2009	P00	All	LTN133AT09-G02 Model spec was issued first.
Oct. 22, 2009	A00	All	LTN133AT09-G02 Model spec was approved.

Samsung Secret

Doc.No.

LTN133AT09-G02

Rev.No

04-A00-S-091022

Page

3 / 26

GENERAL DESCRIPTION

DESCRIPTION

LTN133AT09-G02 is a color active matrix TFT (Thin Film Transistor) liquid crystal display (LCD) that uses amorphous silicon TFT as a switching devices. This model is composed of a TFT LCD panel, a driver circuit and a backlight unit. The resolution of a 13.3" contains 1,280 x 800 pixels and can display up to 262,144 colors. 6 O'clock direction is the Optimum viewing angle.

FEATURES

- High contrast ratio, high aperture structure
- 1280 x 800 pixels resolution
- Low power consumption
- Fast Response
- W-LED BLU
- DE(Data enable) only mode
- 3.3V LVDS Interface
- Onboard EEDID chip
- RoHS / Halogen free compliance

APPLICATIONS

- Notebook PC
- If the usage of this product is not for PC application, but for others, please contact SEC.

GENERAL INFORMATION

Item	Specification	Unit	Note
Display area	286.08(H) x 178.80(V) (13.3" diagonal)	mm	
Driver element	a-Si TFT active matrix		
Display colors	262,144		
Number of pixel	1280 x RGB(3) x 800	pixel	16 : 10
Pixel arrangement	RGB vertical stripe		
Pixel pitch	0.2235(H) x 0.2235(V) (TYP.)	mm	113.6DPI
Display Mode	Normally white		
Surface treatment	Haze 0, Hard-Coating 3H		LT4

Samsung Secret

Mechanical Information

Item		Min.	Typ.	Max.	Unit	Note
Module size	Horizontal (H)	296.85	297.15	297.45	mm	
	Vertical (V)	191.85	192.15	192.45	mm	
	Depth (D)	-	3.38	3.68	mm	
Weight		-	300	310	g	

1. ABSOLUTE MAXIMUM RATINGS

1.1 ENVIRONMENTAL ABSOLUTE RATINGS

Item	Symbol	Min.	Max.	Unit	Note
Storage temperate	TSTG	-20	60	°C	(1)
Operating temperate (Temperature of glass surface)	TOPR	0	50	°C	(1)
Shock (non-operating)	Snop	-	240	G	(2),(4)
Vibration (non-operating)	Vnop	-	2.41	G	(3),(4)

Note (1) Temperature and relative humidity range are shown in the figure below.

95 % RH Max. ($40\text{ }^{\circ}\text{C} \geq T_a$)

Maximum wet - bulb temperature at $39\text{ }^{\circ}\text{C}$ or less. ($T_a > 40\text{ }^{\circ}\text{C}$) No condensation

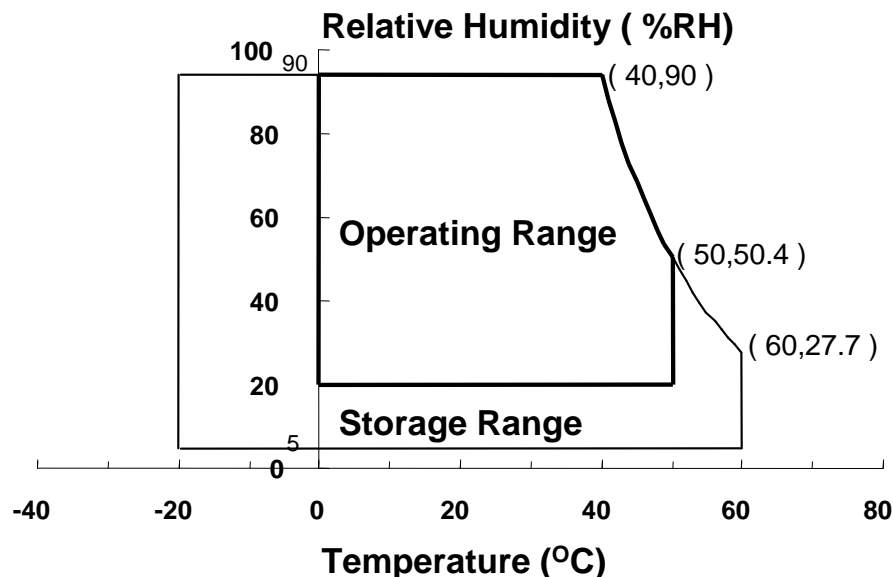

(2) 2ms, half sine wave, one time for $\pm X$, $\pm Y$, $\pm Z$.

(3) 5 - 500 Hz, random vibration, 30min for X, Y, Z.

(4) At testing Vibration and Shock, the fixture in holding the Module to be tested have to be hard and rigid enough so that the Module would not be twisted or bent by the fixture.

Samsung Secret

1.2 ELECTRICAL ABSOLUTE RATINGS

(1) TFT LCD MODULE

$V_{DD} = 3.3V, V_{SS} = GND = 0V$

Item	Symbol	Min.	Max.	Unit	Note
Power Supply Voltage	V_{DD}	$V_{SS} - 0.3$	3.6	V	(1)

Note (1) Within T_a ($25 \pm 2 \text{ }^\circ\text{C}$)

(2) BACK-LIGHT UNIT

$T_a = 25 \pm 2 \text{ }^\circ\text{C}$

Item	Symbol	Min.	Max.	Unit	Note
LED Current	I_L	-	25	mA	(1)
LED Voltage	V_L	2.8	3.6	V	(1)

Note 1) Permanent damage to the device may occur if maximum values are exceeded
 Functional operation should be restricted to the conditions described under normal operating conditions.

2. OPTICAL CHARACTERISTICS

The following items are measured under stable conditions. The optical characteristics should be measured in a dark room or equivalent state with the methods shown in Note (5).
Measuring equipment : TOPCON SR-3

* Ta = 25 ± 2 °C, V_{DD}=3.3V, fv= 60Hz, f_{DCLK} = 72.5MHz, IL = 19.0 mArms

Item	Symbol	Condition	Min.	Typ.	Max	Unit	Note
Contrast Ratio (Center)	CR		600	700	-	-	(1), (2), (5)
Response Time at Ta (Rising + Falling)	T _{RT,BW}		-	16	-	msec	(1), (3)
Average Luminance of White (center)	Y _{L,AVE}		248	275	-	cd/m ²	I _L =19.0mA (1), (4)
Color Chromaticity (CIE)	Red	R _X	0.575	0.595	0.615	-	(1), (5) SR-3
		R _Y	0.300	0.330	0.360		
	Green	G _X	0.305	0.335	0.365		
		G _Y	0.535	0.565	0.595		
	Blue	B _X	0.125	0.155	0.185		
		B _Y	0.100	0.130	0.160		
	White	W _X	0.297	0.313	0.329		
		W _Y	0.313	0.329	0.345		
Color Gamut			-	45	-	%	
Viewing Angle	Hor.	θ _L	65	70	-	Degrees	
		θ _H	65	70	-		
	Ver.	φ _H	50	55	-		
		φ _L	55	60	-		
160 Points White Variation			50	-	-	-	(6)

Samsung Secret

Note 1) Definition of Viewing Angle : Viewing angle range($10 \leq C/R$, $100 \leq C/R$)

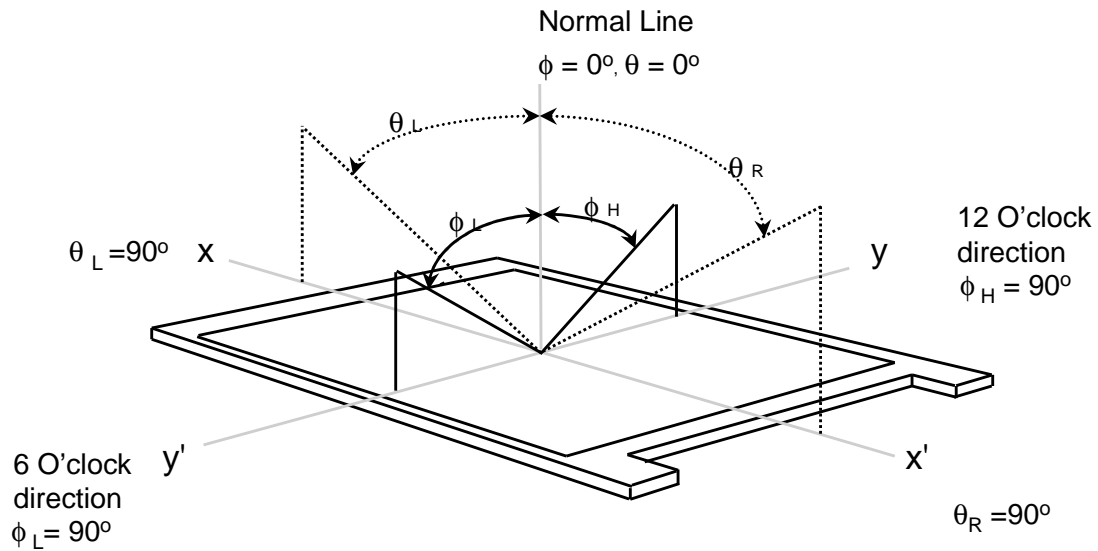

Note 2) Definition of Contrast Ratio (CR) : Ratio of gray max (Gmax), gray min (Gmin) at center point

$$CR = \text{Luminance at Gmax} / \text{Luminance at Gmin}$$

{ Average contrast value at point # 72, 73, 88, 89 },

Test points are figured out at Note 4).

Note 3) Definition of Response time :

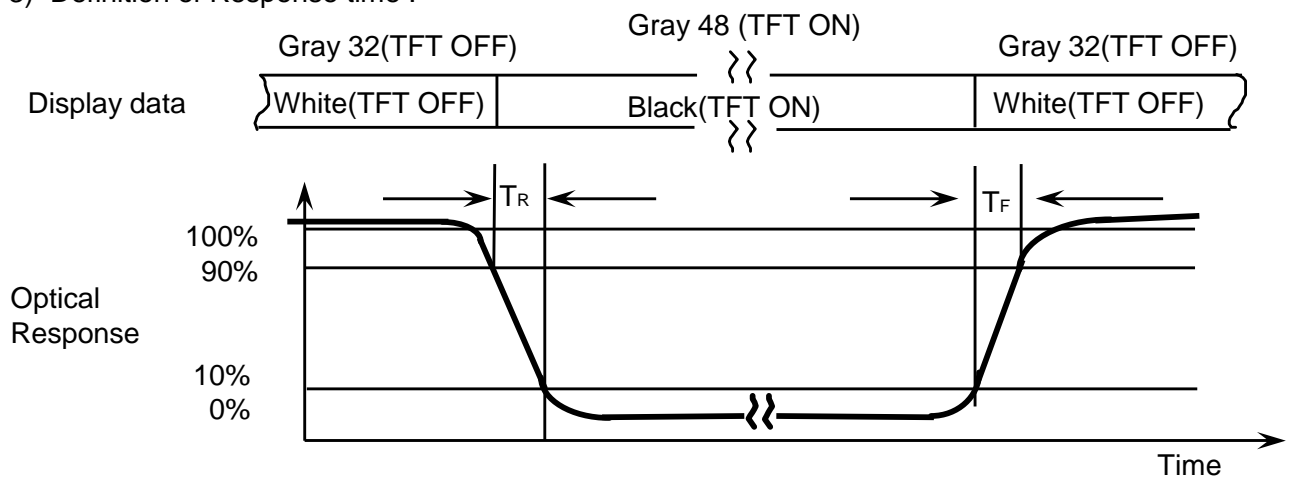

Note 4) Definition of Average Luminance of White

: measure the luminance of white at center 4 points out of 160 points .

Average Luminance of White ($Y_{L,AVE}$)

$$Y_{L,AVE} = \frac{Y_{L72} + Y_{L73} + Y_{L88} + Y_{L89}}{4}$$

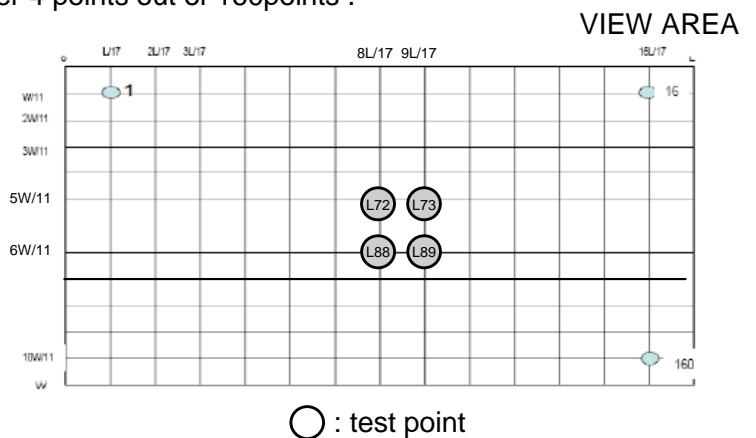

Note 5) After stabilizing and leaving the panel alone at a given temperature for 30 min , the measurement should be executed. Measurement should be executed in a stable, windless, and dark room. 30 min after lighting the backlight. This should be measured in the center of screen.
 Lamp current : 6.0mA (Inverter : SIC-130T)
 Environment condition : $T_a = 25 \pm 2 \text{ } ^\circ\text{C}$

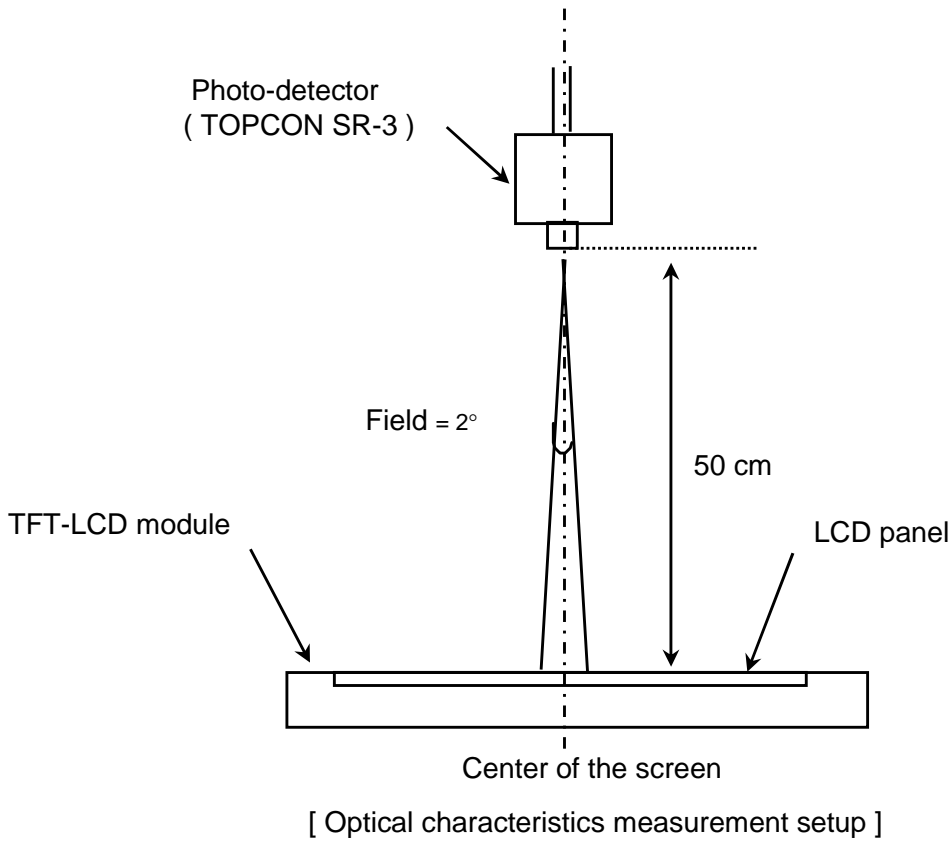

Note 6) Definition of 160 points white variation (δL), CR variation(C_{VER}) [① ~ ①60]

$$\delta L = 100\% - (L_{max} - L_{min}) / L_{max}$$

Where, $L_{max} = \max \{ \text{Luminance values at 160 points} \}$,

$L_{min} = \min \{ \text{Luminance values at 160 points} \}$

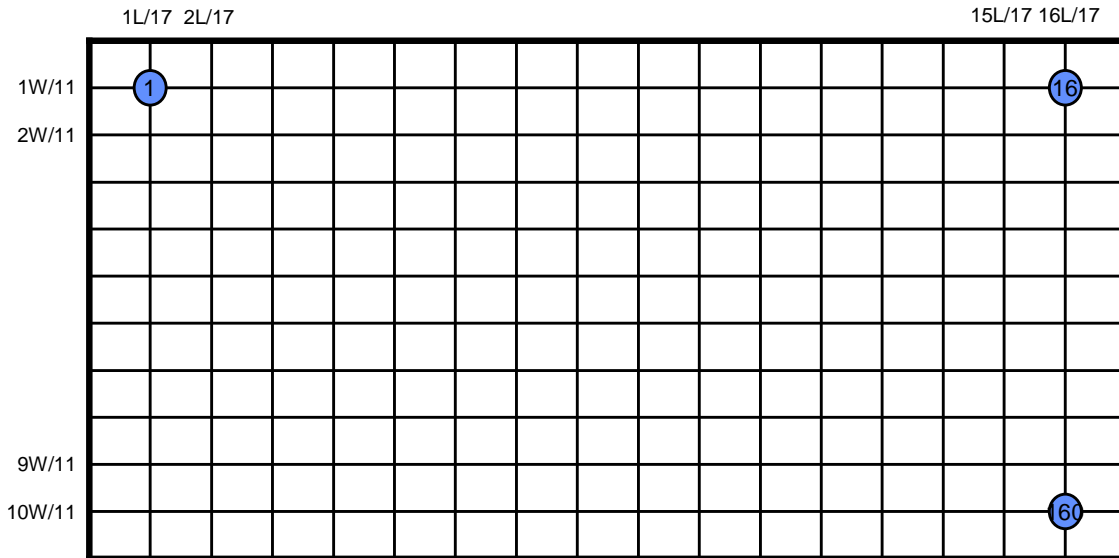

Samsung Secret

3. ELECTRICAL CHARACTERISTICS

Approval

3.1 TFT LCD MODULE

Ta= 25 ± 2°C

Item	Symbol	Min.	Typ.	Max.	Unit	Note	
Voltage of Power Supply	V _{DD}	3.0	3.3	3.6	V		
Differential Input Voltage for LVDS Receiver Threshold	High	V _{IH}	-	-	+100	mV	V _{CM} = +1.2V
	Low	V _{IL}	-100	-	-	mV	
Vsync Frequency	f _v	-	60	-	Hz		
Hsync Frequency	f _H	-	50.8	-	KHz		
Main Frequency	f _{DCLK}	-	72.2	-	MHz		
Rush Current	I _{RUSH}	-	-	1.5	A	(4)	
Current of Power Supply	White	I _{DD}	-	230	-	mA	(2),(3)*a
	Mosaic		-	242	273	mA	(2),(3)*b
	Black		-	273	303	mA	(2),(3)

Note (1) Display data pins and timing signal pins should be connected.(GND = 0V)

(2) f_v = 60Hz, f_{DCLK} = 72.5MHz, V_{DD} = 3.3V , DC Current.

(3) Power dissipation pattern

*a) White Pattern

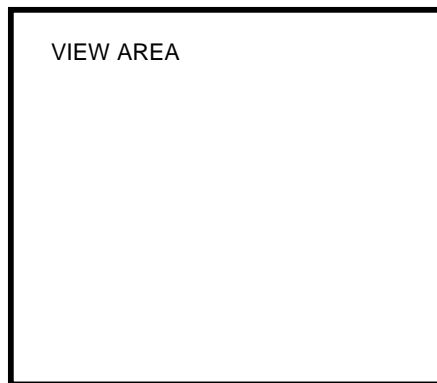

*b) Mosaic Pattern

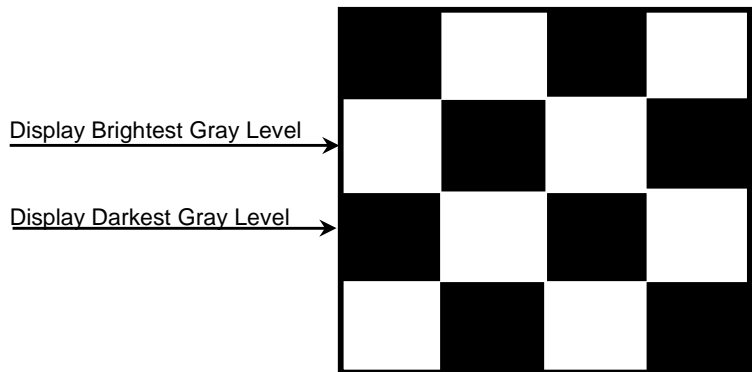

Samsung Secret

4) Rush current measurement condition

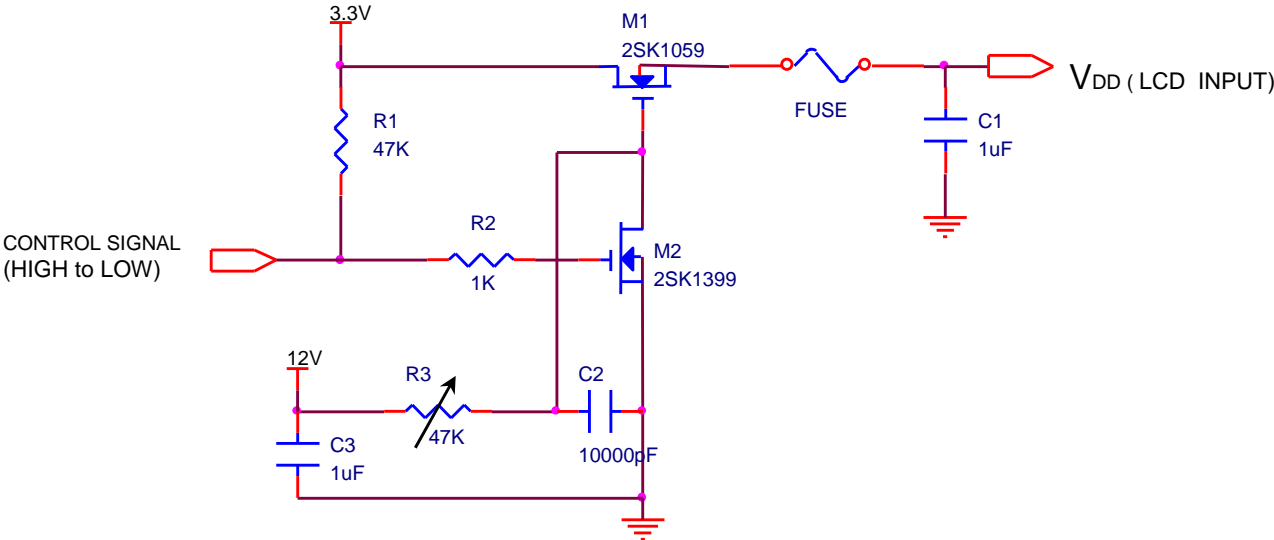

V_{DD} rising time is 470us

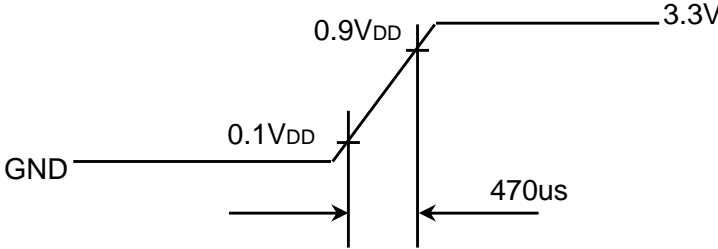

3.2 BACK-LIGHT UNIT

Ta= 25 ± 2 °C

Item	Symbol	Min.	Typ.	Max.	Unit	Note
LED Forward Current	IF	-	19	-	mA	
LED Forward Voltage	VF	-	3.3	3.45	V	
LED Array Voltage	VP	-	29.7	30.6V	V	Vf X 9 LEDs
Power Consumption	P	-	3.39	-	W	If X Vf X 54 LEDs

3.3 LED array

String	LED1	LED2	LED3	LED4	LED5	LED6	LED7	LED8	LED9
1	1	7	13	19	25	31	37	43	49
2	2	8	14	20	26	32	38	44	50
3	3	9	15	21	27	33	39	45	51
4	4	10	16	22	28	34	40	46	52
5	5	11	17	23	29	35	41	47	53
6	6	12	18	24	30	36	42	48	54

3.4 LED information

LED Manufacturer	Nichia
LED P/N	NNSW108T-S1
LED Bin	No-Need-To-Mix Bins:a5286, a5288, a6275, a6277, a6276, a6278 Mix Pairs: a5276-a6276, a5276-a6278, a5278-a6276, a5278-a6278 a5285-a6285, a5285-a6287, a5287-a6285, a5287-a6287
LED rank	1800mcd to 2400mcd
LED Brightness Bin	50mcd per bin

4. BLOCK DIAGRAM

4.1 TFT LCD Module

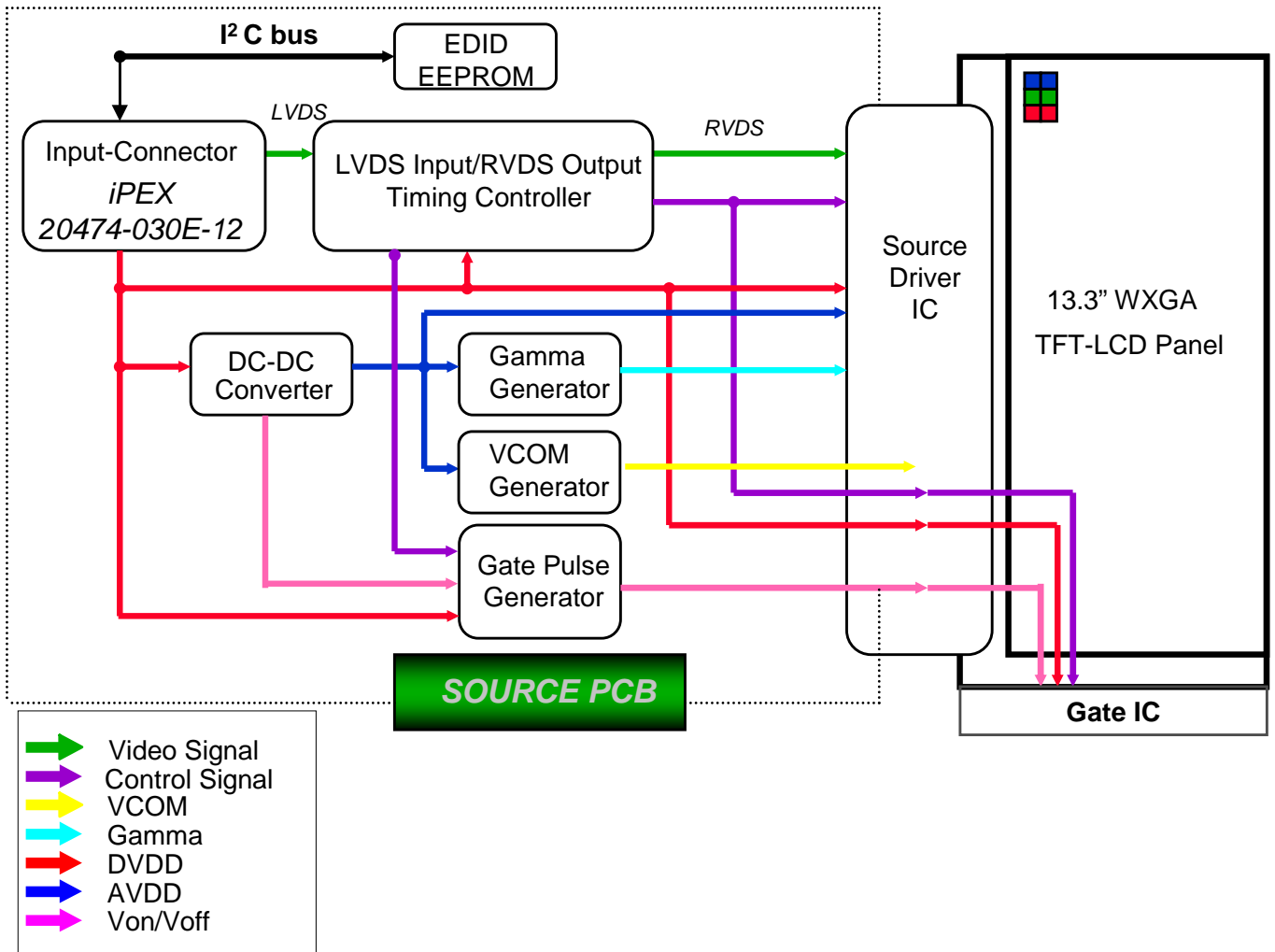

4.2 Back light Unit (LED)

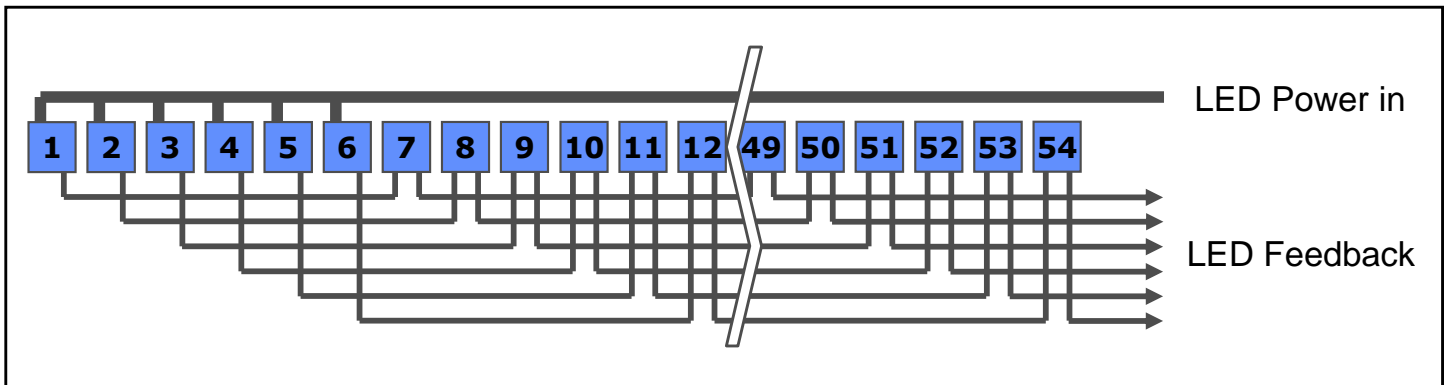

5. INPUT TERMINAL PIN ASSIGNMENT

5.1. Input Signal & Power (LVDS, Connector : IPEX 20474-030E-12)

No.	Symbol	Function	Polarity	Remarks
1	VSS	Ground		
2	VDD	POWER SUPPLY +3.3V		
3	VDD	POWER SUPPLY +3.3V		
4	VEEDID	DDC 3.3V Power		
5	VSUNC	STV out		
6	CLKEDID	DDC Clock		
7	DATAEDID	DDC data		
8	RxIN0-	LVDS Differential Data INPUT (R0-R5,G0)	Negative	
9	RxIN0+	LVDS Differential Data INPUT (R0-R5,G0)	Positive	
10	GND	Ground		
11	RxIN1-	LVDS Differential Data INPUT (G1-G5,B0-B1)	Negative	
12	RxIN1+	LVDS Differential Data INPUT (Odd G1-G5,B0-B1)	Positive	
13	GND	Ground		
14	RxIN2-	LVDS Differential Data INPUT (B2-B5,Sync,DE)	Negative	
15	RxIN2+	LVDS Differential Data INPUT (B2-B5,Sync,DE)	Positive	
16	GND	Ground		
17	RxCLK-	LVDS Differential Data INPUT	Negative	
18	RxCLK+	LVDS Differential Data INPUT	Positive	
19	GND	Ground		
20	WPN	Bist		
21	Vdc (1 to 6)	LED Annode	Positive	
22	Vdc (1 to 6)	LED Annode		
23	NC	NC		
24	Vdc1	LED Cathode	Negative	
25	Vdc2	LED Cathode	Negative	
26	Vdc3	LED Cathode	Negative	
27	Vdc4	LED Cathode	Negative	
28	Vdc5	LED Cathode	Negative	
29	Vdc6	LED Cathode	Negative	
30	NC	NC		

Samsung Secret

5.2 LVDS Interface : Transmitter DS90CF383 or Compatible

Pin No.	Name	RGB Signal	Pin No.	Name	RGB Signal
51	TxIN0	R0	14	TxIN14	G5
52	TxIN1	R1	15	TxIN15	B0
54	TxIN2	R2	19	TxIN18	B1
55	TxIN3	R3	20	TxIN19	B2
56	TxIN4	R4	22	TxIN20	B3
3	TxIN6	R5	23	TxIN21	B4
4	TxIN7	G0	24	TxIN22	B5
6	TxIN8	G1	27	TxIN24	Hsync
7	TxIN9	G2	28	TxIN25	Vsync
11	TxIN12	G3	30	TxIN26	DE
12	TxIN13	G4	31	TxCLKIN	Clock

LVDS INTERFACE

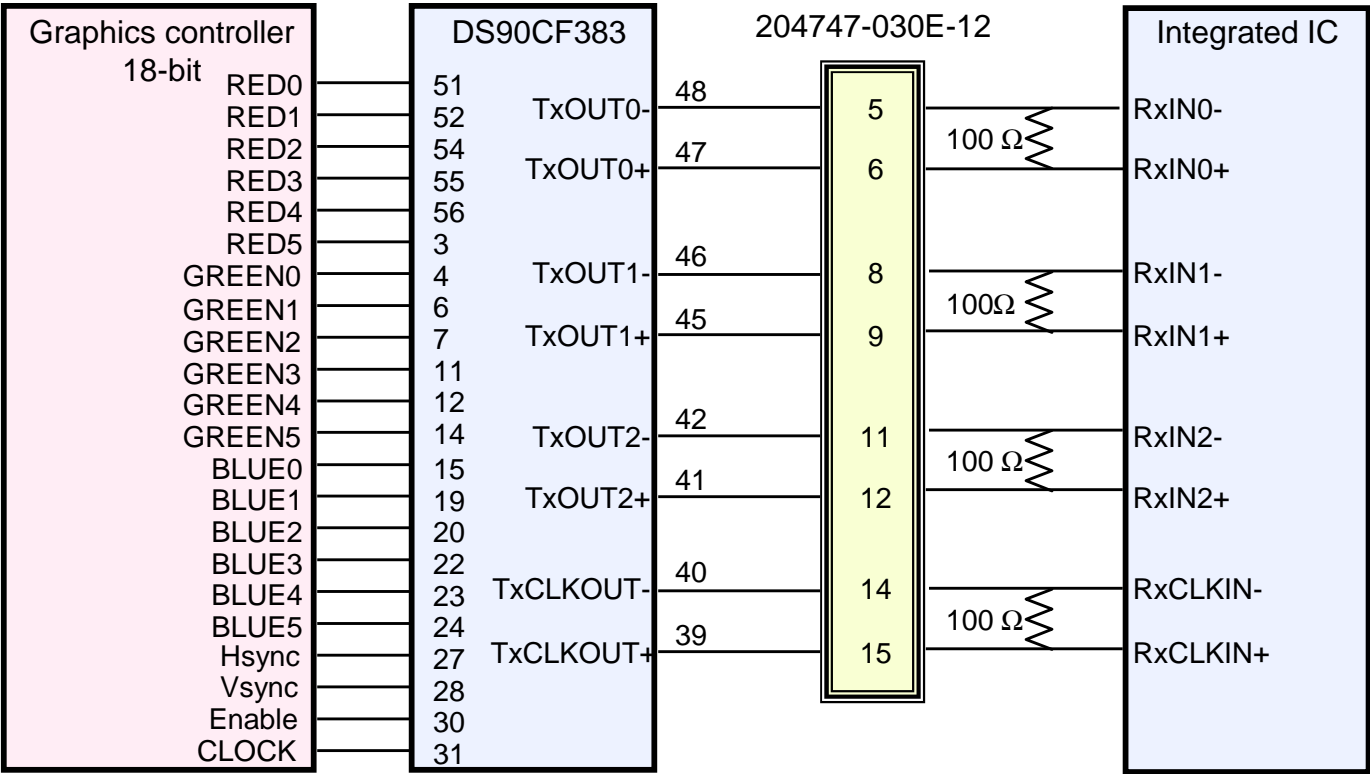

Samsung Secret

박성민00227203충청기술1파트(LCD)1292122117 20091023152405

020761256278830

5.3 Timing Diagrams of LVDS For Transmission

LVDS Receiver : Integrated T-CON

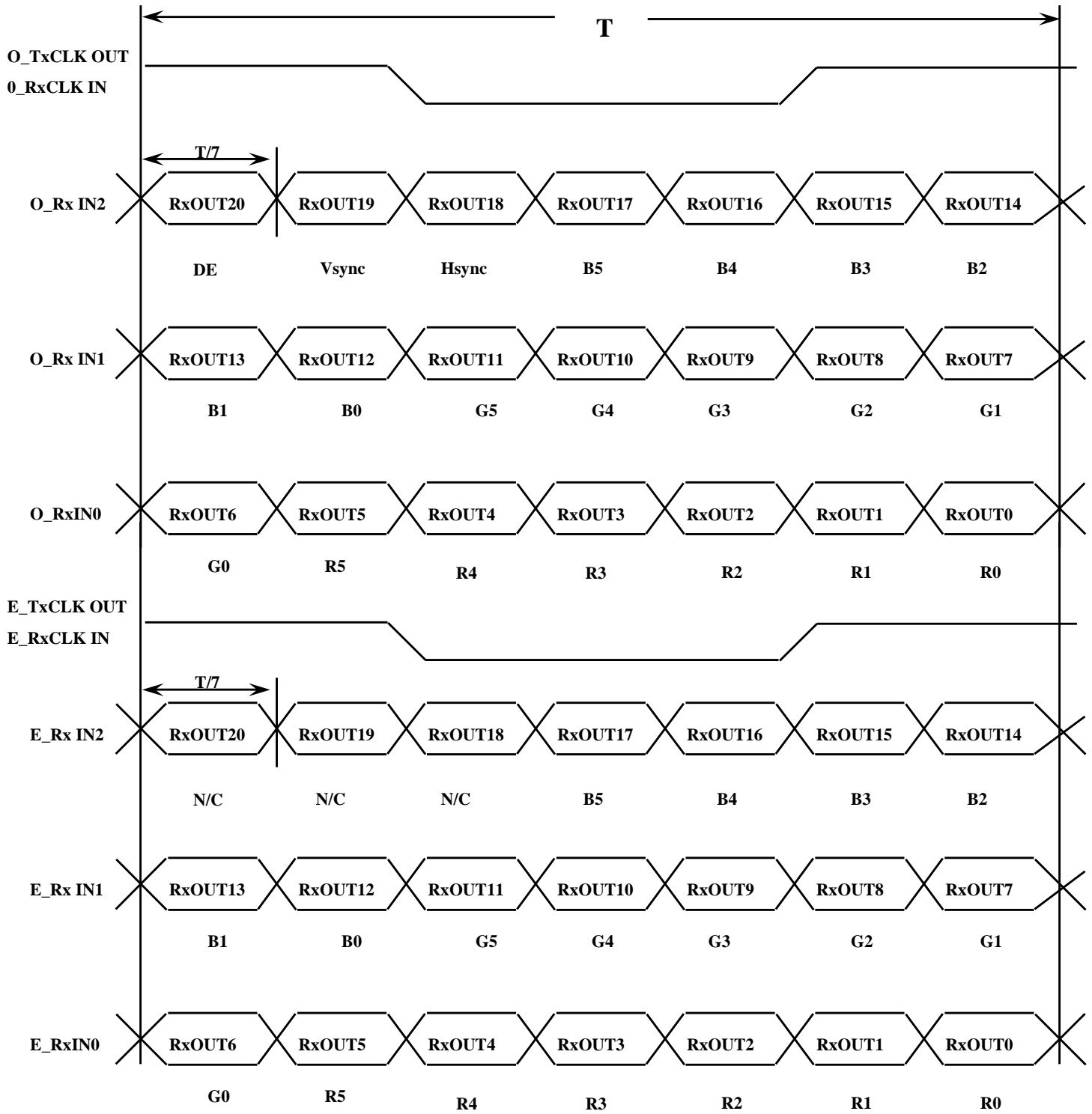

5.4 Input Signals, Basic Display Colors and Gray Scale of Each Color

Color	Display	Data Signal																		Gray Scale Level
		Red						Green						Blue						
		R0	R1	R2	R3	R4	R5	G0	G1	G2	G3	G4	G5	B0	B1	B2	B3	45	B5	
Basic Colors	Black	0	0	0	0	0	0	0	0	0	0	0	0	0	0	0	0	0	0	-
	Blue	0	0	0	0	0	0	0	0	0	0	0	0	1	1	1	1	1	1	-
	Green	0	0	0	0	0	0	1	1	1	1	1	1	0	0	0	0	0	0	-
	Cyan	0	0	0	0	0	0	1	1	1	1	1	1	1	1	1	1	1	1	-
	Red	1	1	1	1	1	1	0	0	0	0	0	0	0	0	0	0	0	0	-
	Magenta	1	1	1	1	1	1	0	0	0	0	0	0	1	1	1	1	1	1	-
	Yellow	1	1	1	1	1	1	1	1	1	1	1	1	0	0	0	0	0	0	-
	White	1	1	1	1	1	1	1	1	1	1	1	1	1	1	1	1	1	1	-
Gray Scale Of Red	Black	0	0	0	0	0	0	0	0	0	0	0	0	0	0	0	0	0	R0	
	Dark	1	0	0	0	0	0	0	0	0	0	0	0	0	0	0	0	0	R1	
	↑	0	1	0	0	0	0	0	0	0	0	0	0	0	0	0	0	0	R2	
	:	:	:	:	:	:	:	:	:	:	:	:	:	:	:	:	:	:	R3~R60	
	:	:	:	:	:	:	:	:	:	:	:	:	:	:	:	:	:	:		
	↓	1	0	1	1	1	1	0	0	0	0	0	0	0	0	0	0	0	R61	
	Light	0	1	1	1	1	1	0	0	0	0	0	0	0	0	0	0	0	R62	
	Red	1	1	1	1	1	1	0	0	0	0	0	0	0	0	0	0	0	R63	
Gray Scale Of Green	Black	0	0	0	0	0	0	0	0	0	0	0	0	0	0	0	0	0	G0	
	Dark	0	0	0	0	0	0	1	0	0	0	0	0	0	0	0	0	0	G1	
	↑	0	0	0	0	0	0	0	1	0	0	0	0	0	0	0	0	0	G2	
	:	:	:	:	:	:	:	:	:	:	:	:	:	:	:	:	:	:	G3~G60	
	:	:	:	:	:	:	:	:	:	:	:	:	:	:	:	:	:	:		
	↓	0	0	0	0	0	0	1	0	1	1	1	1	0	0	0	0	0	G61	
	Light	0	0	0	0	0	0	0	1	1	1	1	1	0	0	0	0	0	G62	
	Green	0	0	0	0	0	0	1	1	1	1	1	1	0	0	0	0	0	G63	
Gray Scale Of Blue	Black	0	0	0	0	0	0	0	0	0	0	0	0	0	0	0	0	0	B0	
	Dark	0	0	0	0	0	0	0	0	0	0	0	1	0	0	0	0	0	B1	
	↑	0	0	0	0	0	0	0	0	0	0	0	0	1	0	0	0	0	B2	
	:	:	:	:	:	:	:	:	:	:	:	:	:	:	:	:	:	:	B3~B60	
	:	:	:	:	:	:	:	:	:	:	:	:	:	:	:	:	:	:		
	↓	0	0	0	0	0	0	0	0	0	0	0	0	1	0	1	1	1	B61	
	Light	0	0	0	0	0	0	0	0	0	0	0	0	0	1	1	1	1	B62	
	Blue	0	0	0	0	0	0	0	0	0	0	0	0	1	1	1	1	1	B63	

Note 1) Definition of gray :

Rn: Red gray, Gn: Green gray, Bn: Blue gray (n=gray level)

Note 2) Input signal: 0 =Low level voltage, 1=High level voltage

Samsung Secret

5.5 Pixel Format in the display

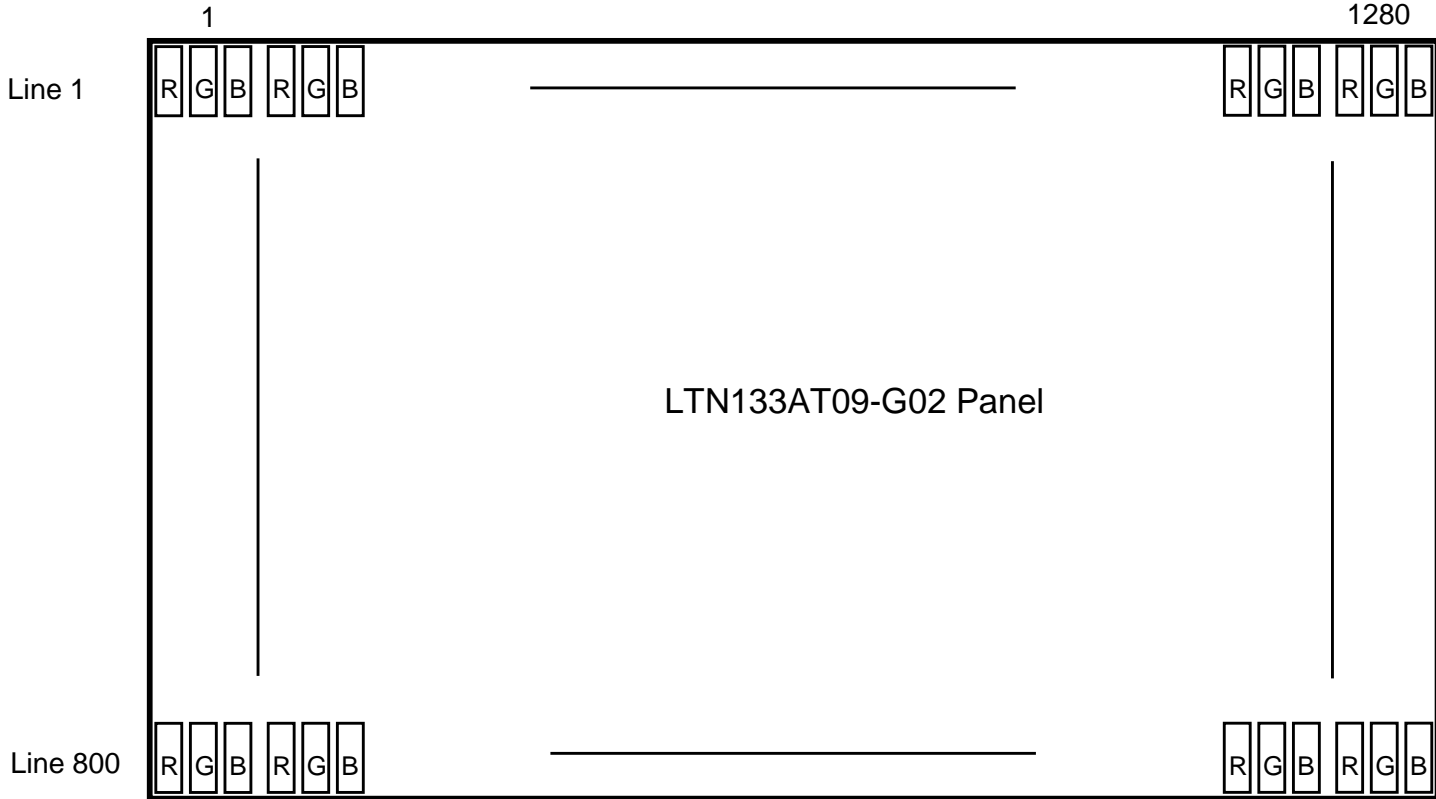

Samsung Secret

6. INTERFACE TIMING

6.1 Timing Parameters

Signal	Item	Symbol	Min.	Typ.	Max.	Unit	Note
Frame Frequency	Cycle	TV	-	846	-	Lines	
Vertical Active Display Term	Display Period	TVD	-	800	-	Lines	
One Line Scanning Time	Cycle	TH	-	1423	-	Clocks	
Horizontal Active Display Term	Display Period	THD	-	1280	-	Clocks	

6.2 Timing diagrams of interface signal

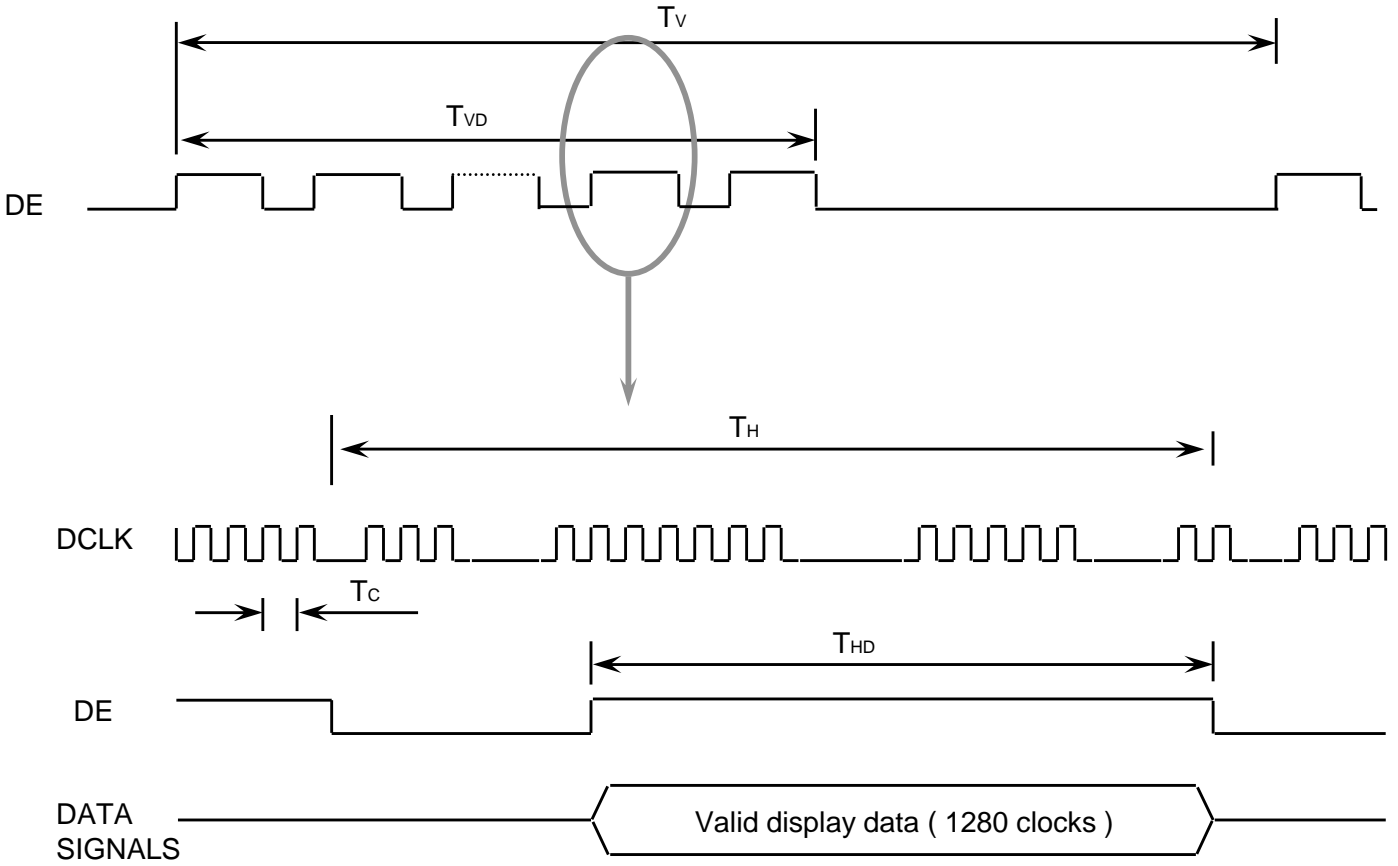

Samsung Secret

6.3 Power ON/OFF Sequence

Approval

: To prevent a latch-up or DC operation of the LCD module, the power on/off sequence should be as the diagram below.

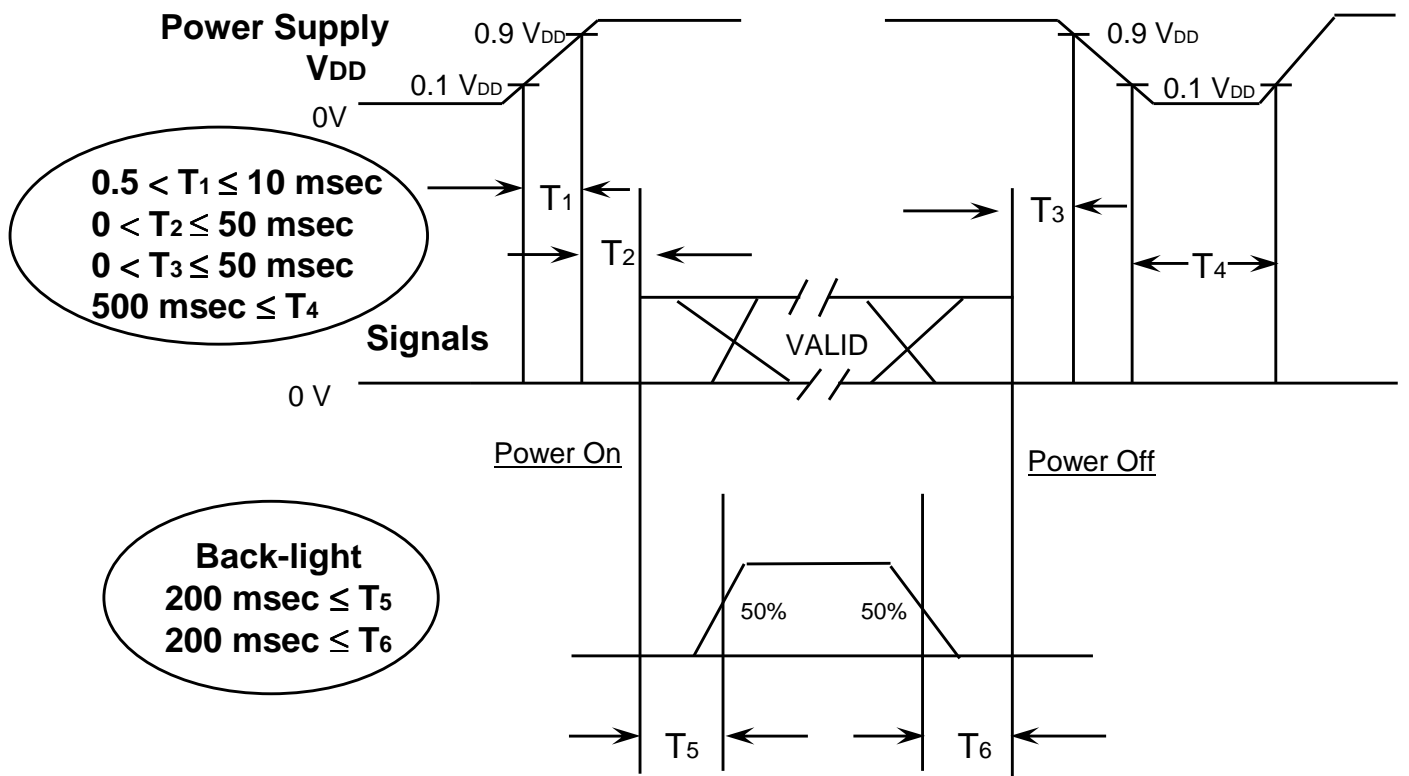

- T1 : Vdd rising time from 10% to 90%
- T2 : The time from Vdd to valid data at power ON.
- T3 : The time from valid data off to Vdd off at power Off.
- T4 : Vdd off time for Windows restart
- T5 : The time from valid data to B/L enable at power ON.
- T6 : The time from valid data off to B/L disable at power Off.

NOTE.

- (1) The supply voltage of the external system for the module input should be the same as the definition of VDD.
- (2) Apply the lamp voltage within the LCD operation range. When the back-light turns on before the LCD operation or the LCD turns off before the back-light turns off, the display may momentarily become white.
- (3) In case of VDD = off level, please keep the level of input signals on the low or keep a high impedance.
- (4) T4 should be measured after the module has been fully discharged between power off and on period.
- (5) Interface signal shall not be kept at high impedance when the power is on.

Samsung Secret

7. Mechanical Outline Dimension

Approval

Next page

Samsung Secret

Doc.No.

LTN133AT09-G02

Rev.No

04-A00-S-091022

Page

21 / 26

8. GENERAL PRECAUTIONS

Approval

1. Handling

- (a) When the module is assembled, It should be attached to the system firmly using every mounting holes. Be careful not to twist and bend the modules.
- (b) Refrain from strong mechanical shock and / or any force to the module. In addition to damage, this may cause improper operation or damage to the module and CCFT back-light.
- (c) Note that polarizers are very fragile and could be easily damaged. Do not press or scratch the surface harder than a HB pencil lead.
- (d) Wipe off water droplets or oil immediately. If you leave the droplets for a long time, Staining and discoloration may occur.
- (e) If the surface of the polarizer is dirty, clean it using some absorbent cotton or soft cloth.
- (f) The desirable cleaners are water, IPA (Isopropyl Alcohol) or Hexane. Do not use Ketone type materials(ex. Acetone), Ethyl alcohol, Toluene, Ethyl acid or Methyl chloride. It might permanent damage to the polarizer due to chemical reaction.
- (g) If the liquid crystal material leaks from the panel, it should be kept away from the eyes or mouth . In case of contact with hands, legs or clothes, it must be washed away thoroughly with soap.
- (h) Protect the module from static , it may cause damage to the C-MOS Gate Array IC.
- (i) Use fingerstalls with soft gloves in order to keep display clean during the incoming inspection and assembly process.
- (j) Do not disassemble the module.
- (k) Do not pull or fold the lamp wire.
- (l) Do not adjust the variable resistor which is located on the back side.
- (m) Protection film for polarizer on the module shall be slowly peeled off just before use so that the electrostatic charge can be minimized.
- (n) Pins of I/F connector shall not be touched directly with bare hands.

Samsung Secret

2. STORAGE

Approval

- (a) Do not leave the module in high temperature, and high humidity for a long time. It is highly recommended to store the module with temperature from 0 to 35 °C and relative humidity of less than 70%.
- (b) Do not store the TFT-LCD module in direct sunlight.
- (c) The module shall be stored in a dark place. It is prohibited to apply sunlight or fluorescent light during the store.

3. OPERATION

- (a) Do not connect,disconnect the module in the “ Power On” condition.
- (b) Power supply should always be turned on/off by following item 6.3 “ Power on/off sequence “.
- (c) Module has high frequency circuits. Sufficient suppression to the electromagnetic interference shall be done by system manufacturers. Grounding and shielding methods may be important to minimize the interference.
- (d) The cable between the back-light connector and its inverter power supply shall be a minimized length and be connected directly . The longer cable between the back-light and the inverter may cause lower luminance of lamp(CCFT) and may require higher startup voltage (Vs).
- (e) The standard limited warranty is only applicable when the module is used for general notebook applications. If used for purposes other than as specified, SEC is not to be held reliable for the defective operations. It is strongly recommended to contact SEC to find out fitness for a particular purpose.

4. OTHERS

- (a) Ultra-violet ray filter is necessary for outdoor operation.
- (b) Avoid condensation of water. It may result in improper operation or disconnection of electrode.
- (c) Do not exceed the absolute maximum rating value. (the supply voltage variation, input voltage variation, variation in part contents and environmental temperature, so on) Otherwise the module may be damaged.
- (d) If the module displays the same pattern continuously for a long period of time,it can be the situation when the image “sticks” to the screen.
- (e) This module has its circuitry PCB's on the rear side and should be handled carefully in order not to be stressed.

Samsung Secret

EDID Table LTN133AT09-G02

2009.4.17

Address (Decimal)	Address (HEX)	Field Name & Comments	Value (HEX)	Value (BIN)	Value (DEC)
0	0	Header	00	00000000	0
1	1		FF	11111111	255
2	2		FF	11111111	255
3	3		FF	11111111	255
4	4		FF	11111111	255
5	5		FF	11111111	255
6	6		FF	11111111	255
7	7		00	00000000	0
8	8	EISA Manuf. Code LSB (3 character ID = APP)	06	00000110	6
9	9	Compressed ASCII	10	00010000	16
10	0A	Product Code = C0	C0	11000000	192
11	0B	hex, LSB first = 9C	9C	10011100	156
12	0C	32-bit serial #	00	00000000	0
13	0D		00	00000000	0
14	0E		00	00000000	0
15	0F		00	00000000	0
16	10	Week of manufacture (week 35)	23	00100011	35
17	11	Year of manufacture (2009)	13	00010011	19
18	12	EDID Structure Ver # = 1	01	00000001	1
19	13	EDID revision # = 3	03	00000011	3
20	14	Video input definition = Digital input, Non TMDS CRGB	80	10000000	128
21	15	Max H image size = 29 Cm	1D	00011101	29
22	16	Max V image size = 18 Cm	12	00010010	18
23	17	Display Gamma = 2.2	78	01111000	120
24	18	Feature support (DPMS) = Active off, RGB color	0A	00001010	10
25	19	Red/green low bits	50	01010000	80
26	1A	Blue/white low bits	C5	11000101	197
27	1B	Red x , Red x = 0.595	98	10011000	152
28	1C	Red y , Red y = 0.345	58	01011000	88
29	1D	Green x , Green x = 0.320	52	01010010	82
30	1E	Green y , Green y = 0.555	8E	10001110	142
31	1F	Blue x , Blue x = 0.155	27	00100111	39
32	20	Blue y , Blue y = 0.145	25	00100101	37
33	21	White x , White x = 0.313	50	01010000	80
34	22	White y , White y = 0.329	54	01010100	84
35	23	Established timing 1	00	00000000	0
36	24	Established timing 2	00	00000000	0
37	25	Manufacturer's timings	00	00000000	0
38	26	Standard timing #1 was not used	01	00000001	1
39	27		01	00000001	1
40	28	Standard timing #2 was not used	01	00000001	1
41	29		01	00000001	1
42	2A	Standard timing #3 was not used	01	00000001	1
43	2B		01	00000001	1
44	2C	Standard timing #4 was not used	01	00000001	1
45	2D		01	00000001	1
46	2E	Standard timing #5 was not used	01	00000001	1
47	2F		01	00000001	1
48	30	Standard timing #6 was not used	01	00000001	1
49	31		01	00000001	1
50	32	Standard timing #7 was not used	01	00000001	1
51	33		01	00000001	1
52	34	Standard timing #8 was not used	01	00000001	1
53	35		01	00000001	1

Samsung Secret

박성민00227203등록기술1파트(LCD)1292122117 20091023152405

020761256278830

EDID Table LTN133AT09-G02

2009.4.17

Address (Decimal)	Address (HEX)	Field Name & Comments	Value (HEX)	Value (BIN)	Value (DEC)
54	36	Detailed timing/monitor	EE	11101110	238
55	37	1280x800 @60.223Hz : Pixel Clock = 72.50 MHz	1A	00011010	26
56	38	Hor active=1280 pixels	00	00000000	0
57	39	Hor blanking=143 pixels	80	10000000	128
58	3A		50	01010000	80
59	3B	Vertical active=800 lines	20	00100000	32
60	3C	Vertical blanking=46lines	10	00010000	16
61	3D		30	00110000	48
62	3E	H sync. Offset=48 pixels	10	00010000	16
63	3F	H sync. Width=32 pixels	30	00110000	48
64	40	V sync. Offset=3 lines	13	00010011	19
65	41	V sync. Width=6 lines	00	00000000	0
66	42	H image size= 286 mm	05	00000101	5
67	43	V image size = 179 mm	A3	10100011	163
68	44		10	00010000	16
69	45	No Horizontal Border	00	00000000	0
70	46	No Vertical Border	00	00000000	0
71	47	Non-interlaced, Normal display, No stereo, Digital separate sync, H/V pol Negatives	19	00011001	25
72	48	Detailed timing/monitor	00	00000000	0
73	49	descriptor #3	00	00000000	0
74	4A		00	00000000	0
75	4B		01	00000001	1
76	4C	Version	00	00000000	0
77	4D	Apple edid signature	06	00000110	6
78	4E	Apple edid signature	10	00010000	16
79	4F	Link Type (LVDS Link,MSB justified)	20	00100000	32
80	50	Pixel and link component format (6-bit panel interface)	00	00000000	0
81	51	Panel features (No inverter)	00	00000000	0
82	52		00	00000000	0
83	53		00	00000000	0
84	54		00	00000000	0
85	55		00	00000000	0
86	56		00	00000000	0
87	57		00	00000000	0
88	58		0A	00001010	10
89	59		20	00100000	32
90	5A	Detailed timing/monitor	00	00000000	0
91	5B	descriptor #3	00	00000000	0
92	5C	LTN133AT09-G01	00	00000000	0
93	5D		FE	11111110	254
94	5E		00	00000000	0
95	5F	L	4C	01001100	76
96	60	T	54	01010100	84
97	61	N	4E	01001110	78
98	62	1	31	00110001	49
99	63	3	33	00110011	51
100	64	3	33	00110011	51
101	65	A	41	01000001	65
102	66	T	54	01010100	84
103	67	0	30	00110000	48
104	68	9	39	00111001	57
105	69		00	00000000	0
106	6A		0A	00001010	10
107	6B		20	00100000	32

Samsung Secret

박상민00227203등록기술1파트(LCD)1292122117 20091023152405

020761256278830

EDID Table LTN133AT09-G02

2009.4.17

Address (Decimal)	Address (HEX)	Field Name & Comments	Value (HEX)	Value (BIN)	Value (DEC)
108	6C	Detailed timing/monitor	00	00000000	0
109	6D	descriptor #4	00	00000000	0
110	6E	Color LCD	00	00000000	0
111	6F		FC	11111100	252
112	70		00	00000000	0
113	71	C	43	01000011	67
114	72	o	6F	01101111	111
115	73	l	6C	01101100	108
116	74	o	6F	01101111	111
117	75	r	72	01110010	114
118	76	space	20	00100000	32
119	77	L	4C	01001100	76
120	78	C	43	01000011	67
121	79	D	44	01000100	68
122	7A		0A	00001010	10
123	7B		20	00100000	32
124	7C		20	00100000	32
125	7D		20	00100000	32
126	7E	Extension Flag = 00	00	00000000	0
127	7F	Checksum	84	10000100	132

Samsung Secret

박상민00227203응용기술1파트(LCD)1292122117 20091023152405

020761256278830