

# R2A20158NP

8-bit 8ch D/A Converter with Buffer Amplifiers for I<sup>2</sup>C BUS (Corresponds to Fast mode)

R03DS0015EJ0100

Rev.1.00

2011.09.05

## Description

The R2A20158NP is an integrated circuit semiconductor of CMOS structure with 8 channels of built in D/A converters with output buffer operational amplifiers. It is the electrical characteristic improvement version of the M62393.

The input is 2-wires serial method is used for the transfer format of digital data to allow connection with a microcomputer with minimum wiring. This IC corresponds to Fast mode of I<sup>2</sup>C BUS standard.

The output buffer operational amplifier employs AB class output circuit with sync and source drive capacity of 1.0mA or more, and it operates in the whole voltage range from V<sub>CC</sub> to ground.

Maximum 8 ICs can be connected to a bus by using 3-chip select pins, so that it is possible to handle up to 64 channels analog data.

## Features

- Guarantee Differential nonlinearity error : +/-0.7LSB, Nonlinearity error : +/-1.0LSB
- Digital data transfer format: I<sup>2</sup>C BUS serial data method (corresponds to Fast mode: 400kHz)
- Output buffer operational amplifier  
It operates in the whole range from V<sub>CC</sub> to ground.
- High output current drive capacity: 1mA over
- The very small size (4mmX4mm) QFN-20 package is added to the lineup.

## Application

Conversion from digital data to analog control data for home-use and industrial equipment.

Signal gain control or automatic adjustment of LCD-TV, PDP-TV or LCD display-monitor.

Blurring correction control or various control of the interchangeable lens of digital camera

## Block Diagram

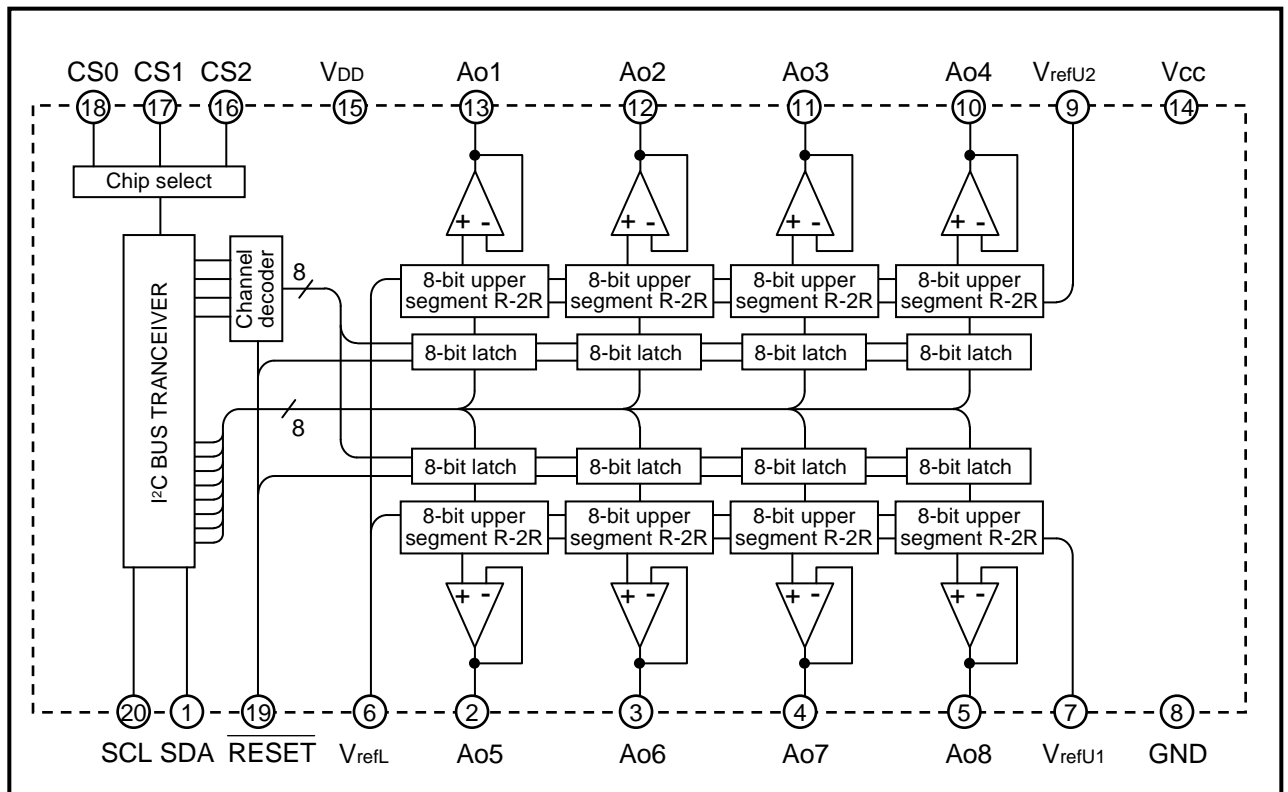

## Pin Arrangement

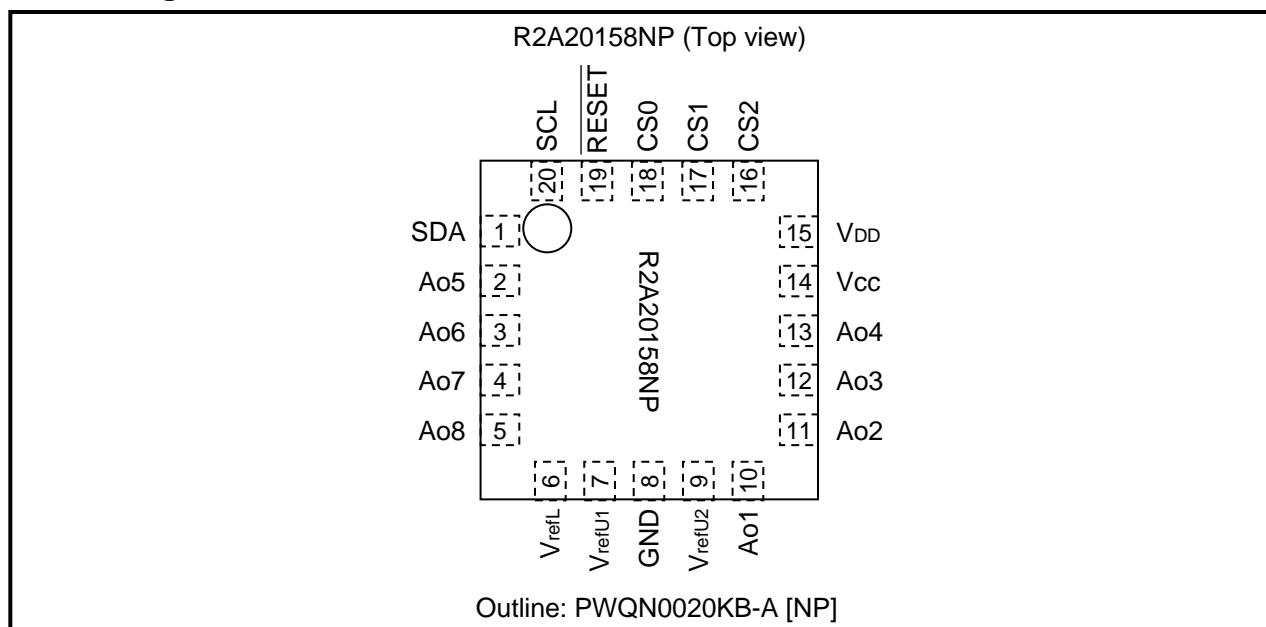

## Pin Description

Pin No.	Pin Name	Function
1	SDA	Serial data input terminal
19	$\overline{\text{RESET}}$	Reset signal input terminal. A low state of $\overline{\text{RESET}}$ clear the all 8-bit latches.
20	SCL	Serial clock input terminal
10	Ao1	8-bit resolution D/A converter output terminal (After power on, analog output of every channel is set in DAC data "00h")
11	Ao2	
12	Ao3	
13	Ao4	
2	Ao5	
3	Ao6	
4	Ao7	
5	Ao8	
14	Vcc	Analog power supply terminal
15	VDD	Digital power supply terminal
8	GND	Analog and digital common GND
6	VrefL	D/A converter low level reference voltage input terminal
7	VrefU1	D/A converter high level reference voltage input terminal 1 (for ch5 to ch8)
9	VrefU2	D/A converter high level reference voltage input terminal 2 (for ch1 to ch4)
16	CS2	Chip select data input terminal 2 *1
17	CS1	Chip select data input terminal 1 *1
18	CS0	Chip select data input terminal 0 *1

\*1 : This IC can be accessed only when the slave address (A0 to A2) coincides with the chip select input (CS0 to CS2).

## Absolute Maximum Ratings

(Ta = 25 deg unless otherwise noted)

Item	Symbol	Conditions	Ratings	Unit
Analog Supply voltage	V <sub>CC</sub>		-0.3 to +6.5	V
Digital Supply voltage	V <sub>DD</sub>		-0.3 to < 6.5	V
Upper reference voltage of D/A *1	V <sub>refU1</sub> , V <sub>refU2</sub>		-0.3 to < 6.5	V
Digital input voltage	V <sub>IN D</sub>		-0.3 to V <sub>DD</sub> +0.3 ≤ 6.5	V
Buffer amplifier output current	I <sub>AO</sub>	Continuous	-2.0 to +2.0	mA
Power dissipation	P <sub>d</sub>	Ta = +85deg	290	mW
Thermal derating factor	K theta	Ta > +25deg	7.25	mW/deg
Operating temperature	T <sub>opr</sub>		-30 to +85	deg
Storage temperature	T <sub>stg</sub>		-40 to +125	deg

\*1 V<sub>DD</sub> ≥ V<sub>refU1</sub>, V<sub>refU2</sub>

## Electrical Characteristics

« Digital Part » (V<sub>CC</sub>, V<sub>DD</sub>, V<sub>refU1</sub>, V<sub>refU2</sub> = +5V +/-10%, V<sub>CC</sub> ≥ V<sub>refU1</sub>, V<sub>refU2</sub>, GND=V<sub>refL</sub>=0V, Ta=-30 to +85deg unless otherwise noted)

Item	Symbol	Test conditions	Limits			Unit
			Min	Typ	Max	
Supply voltage	V <sub>DD</sub>		2.7	5.0	5.5	V
Supply current	I <sub>DD</sub>	CLK = 500kHz operation, I <sub>AO</sub> = 0 μA	-	-	1.0	mA
Input leak current	I <sub>ILK</sub>	V <sub>IN</sub> = 0 to V <sub>CC</sub>	-10	-	10	μA
Output low voltage (SDA)	V <sub>OL</sub>	I <sub>OL</sub> = 3 mA	-	-	0.4	V
Input low voltage	V <sub>IL</sub>		-	-	0.2V <sub>DD</sub>	V
Input high voltage	V <sub>IH</sub>		0.8V <sub>DD</sub>	-	-	V

« Analog Part » (V<sub>CC</sub>, V<sub>DD</sub>, V<sub>refU1</sub>, V<sub>refU2</sub> = +5V +/-10%, V<sub>CC</sub> ≥ V<sub>refU1</sub>, V<sub>refU2</sub>, GND=V<sub>refL</sub>=0V, Ta=-30 to +85deg unless otherwise noted)

Item	Symbol	Test conditions	Limits			Unit
			Min	Typ	Max	
Supply Voltage	V <sub>CC</sub>		2.7	-	5.5	V
Supply current	I <sub>CC</sub>	CLK=500kHz operation, I <sub>AO</sub> = 0μA	-	0.4	1.2	mA
D-A converter high level reference voltage input current	I <sub>refU1, 2</sub>	V <sub>tefU</sub> = 5V, V <sub>refL</sub> = 0V, Data condition: at maximum current for each terminal	-	0.6	1.2	mA
D-A converter high level reference voltage range *2	V <sub>refU1</sub> , V <sub>refU2</sub>		0.7V <sub>CC</sub>	-	V <sub>CC</sub>	V
D-A converter low level reference voltage range *2	V <sub>refL</sub>		GND	-	0.3V <sub>CC</sub>	V
Buffer amplifier output voltage range	V <sub>AO</sub>	I <sub>AO</sub> = +/- 100 μA	0.1	-	V <sub>CC</sub> -0.1	V
		I <sub>AO</sub> = +/- 500 μA	0.2	-	V <sub>CC</sub> -0.2	V
Buffer amplifier output current range	I <sub>AO</sub>	Upper side saturation voltage = 0.3V, Lower side saturation voltage = 0.2V	-1.0	-	1.0	mA
Differential nonlinearity error	S <sub>DL</sub>	V <sub>refU1</sub> , V <sub>refU2</sub> = 4.79V, V <sub>refL</sub> = 0.95V, V <sub>CC</sub> = 5.5V (15mV/LSB), Without load (I <sub>AO</sub> = 0μA)	-0.7	-	0.7	LSB
Nonlinearity error	S <sub>L</sub>		-1.0	-	1.0	LSB
Zero code error	S <sub>ZERO</sub>		-2.0	-	2.0	LSB
Full scale error	S <sub>FULL</sub>		-2.0	-	2.0	LSB
Output capacitive load	C <sub>O</sub>		-	-	0.1	μF
Buffer amplifier output impedance	R <sub>p</sub>		-	5.0	-	ohm

\*2 : The output does not necessary be the value with the reference voltage setting range.

The output value is determined by the buffer amplifier output voltage range (V<sub>AO</sub>).V<sub>DD</sub> ≥ V<sub>refU1</sub>, V<sub>refU2</sub>

## I<sup>2</sup>C BUS Line Characteristics

Item	Symbol	STANDARD MODE		FAST MODE		Unit
		Min.	Max.	Min.	Max.	
SCL clock frequency	fSCL	0	100	0	400	kHz
Free time: the bus must be free before a new transmission can start	tBUF	4.7	-	1.3	-	μs
Hold time START condition after this period, the first clock pulse is generated	tHD:STA	4.0	-	0.6	-	μs
Low period of the clock	tLOW	4.7	-	1.3	-	μs
High period of the clock	tHIGH	4.0	-	0.6	-	μs
Set-up time for START condition. Only relevant for a repeated START condition.	tsu:STA	4.7	-	0.6	-	μs
Data Hold time	tHD:DAT	0	3.45	0	0.9	μs
Data Set-up time	tsu:DAT	250	-	100	-	ns
Rise time of SDA and SCL signals	tR	-	1000	-	300	ns
Fall time of SDA and SCL signals	tF	-	300	-	300	ns
Set-up time for STOP condition	tsu:STO	4.0	-	0.6	-	μs
Capacitive load of bus line	Cb	-	400	-	400	pF

All of above value are corresponds to  $V_{IHmin}$  and  $V_{ILmax}$ .

## Timing Chart

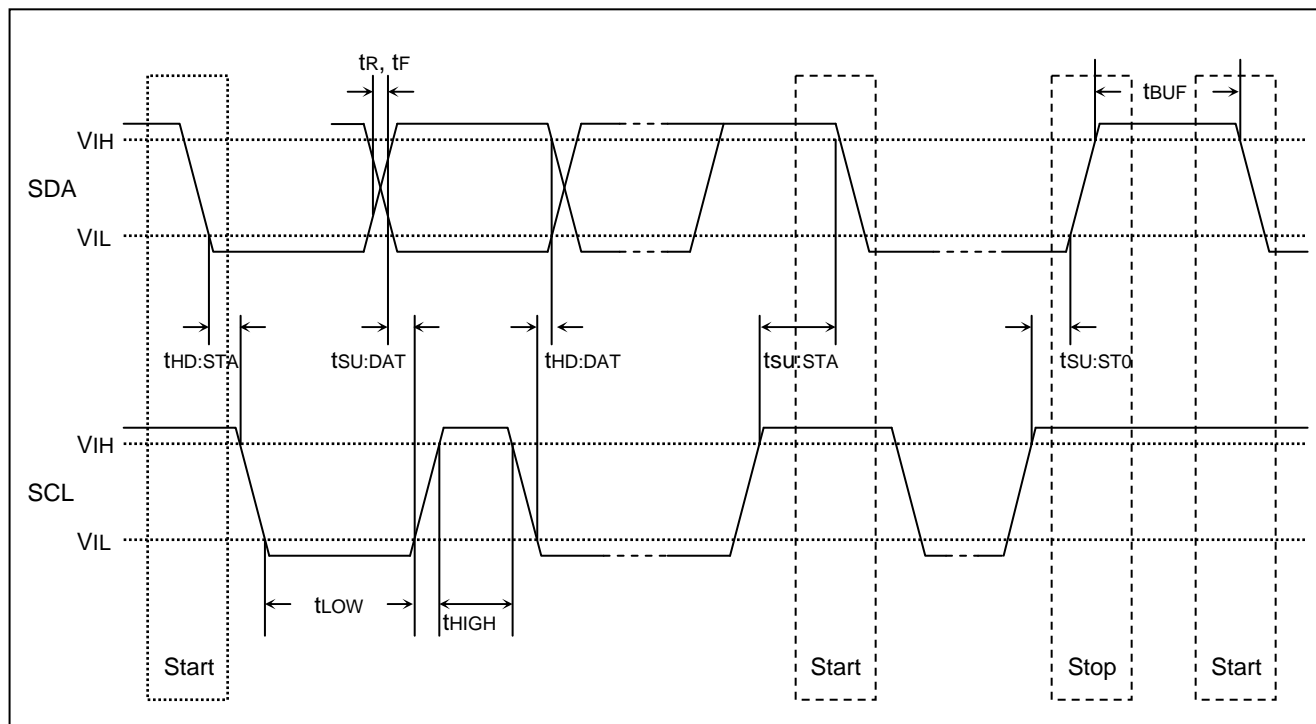

## I<sup>2</sup>C BUS Format

STA	Slave address	W	A	Sub address	A	DAC data	A	STP
-----	---------------	---	---	-------------	---	----------	---	-----

Note: STA: start condition, A: acknowledge bit, W: write (SDA=Low), STP: stop condition

### • Slave address

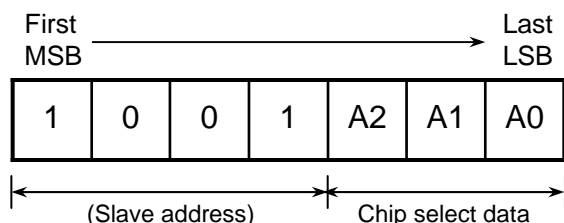

### • Sub address

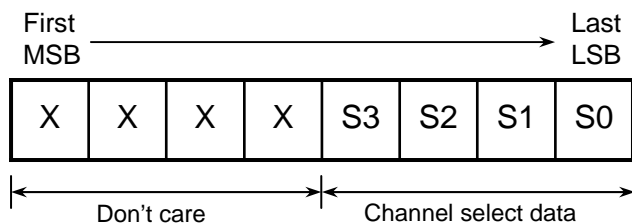

### • DAC data

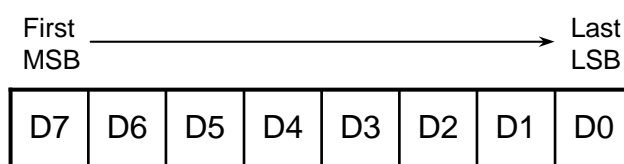

### Chip select data

A2	A1	A0	CS2	CS1	CS0
0	0	0	L	L	L
0	0	1	L	L	H
0	1	0	L	H	L
:	:	:	:	:	:
1	1	1	H	H	H

(L=Low, H=High)

Note: This IC can be accessed only when the lower 3 bits data of slave address (A0 to A2) coincide with the input data of CS0 to CS2.

### Channel select data

S3	S2	S1	S0	Channel selection
0	0	0	0	Don't care
0	0	0	1	ch1 selection
0	0	1	0	ch2 selection
0	0	1	1	ch3 selection
0	1	0	0	ch4 selection
0	1	0	1	ch5 selection
0	1	1	0	ch6 selection
0	1	1	1	ch7 selection
1	0	0	0	ch8 selection
1	0	0	1	Don't care
:	:	:	:	:
1	1	1	1	Don't care

### DAC data

D7	D6	D5	D4	D3	D2	D1	D0	DAC output
0	0	0	0	0	0	0	0	$(V_{refU} - V_{refL}) / 256 \times 1 + V_{refL}$
0	0	0	0	0	0	0	1	$(V_{refU} - V_{refL}) / 256 \times 2 + V_{refL}$
0	0	0	0	0	0	1	0	$(V_{refU} - V_{refL}) / 256 \times 3 + V_{refL}$
0	0	0	0	0	0	1	1	$(V_{refU} - V_{refL}) / 256 \times 4 + V_{refL}$
:	:	:	:	:	:	:	:	:
1	1	1	1	1	1	1	0	$(V_{refU} - V_{refL}) / 256 \times 255 + V_{refL}$
1	1	1	1	1	1	1	1	$V_{refU}$

## Data Timing Chart SCL and SDA (Model)

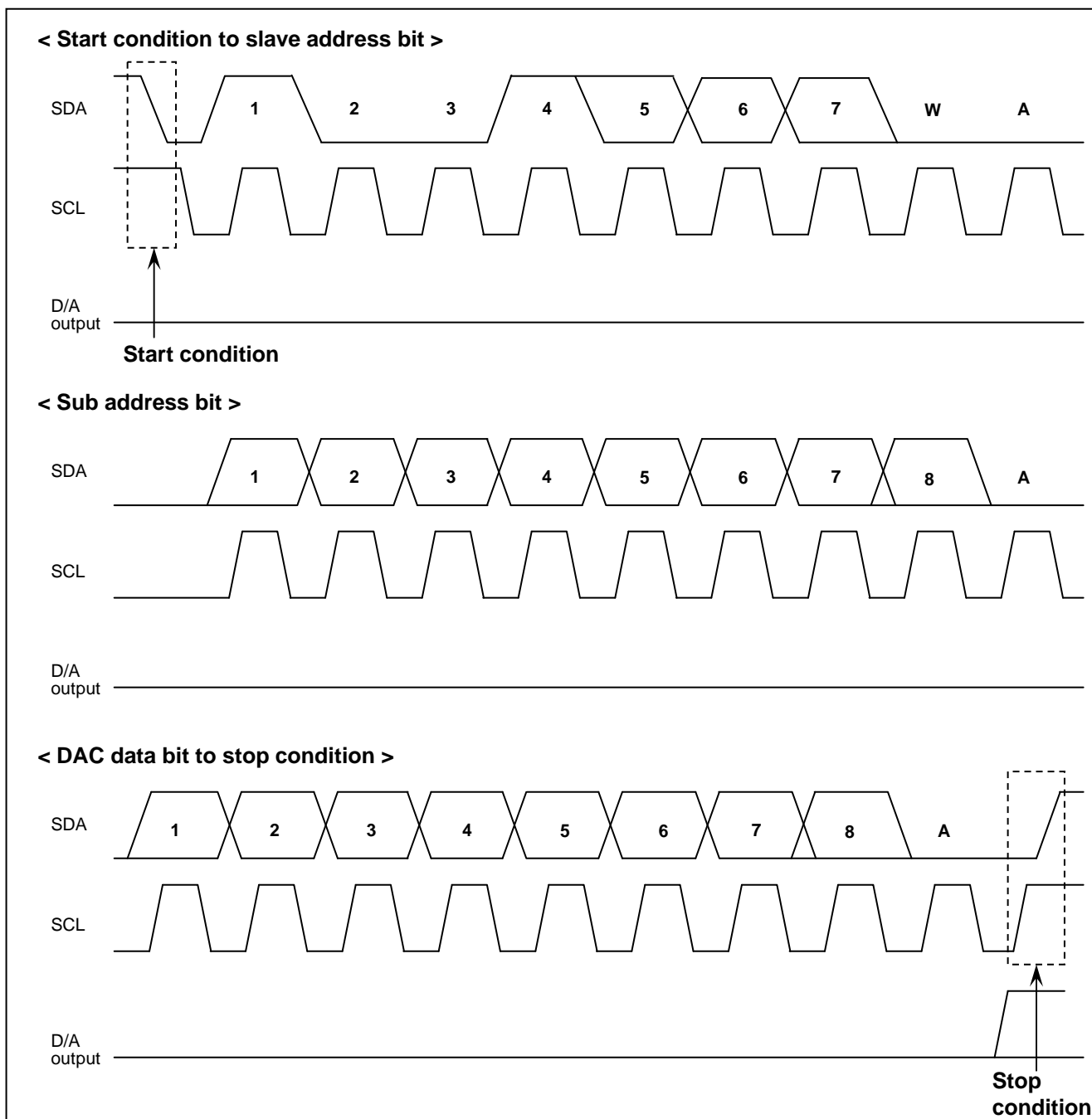

- Start condition With SCL at High, SDA line goes from High to Low
- Stop condition With SCL at High, SDA line goes from Low to High  
( Under normal circumstance, SDA is changed when SCL is Low )
- Acknowledge bit The receiving IC has to pull down SDA line whenever receive slave data.  
( The transmitting IC releases the SDA line just then transmit 8-bit data. )

### Digital Data Format

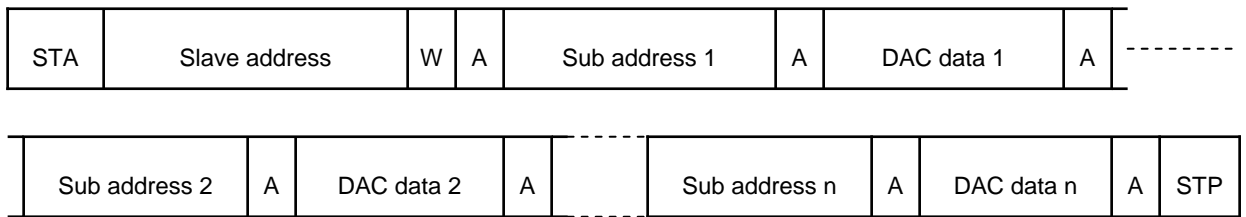

After the Start condition, the transmitting IC accesses the slave IC by Slave address, and transmits the data to each channel by two bites (Sub address and DAC data).

### Precaution For use

- If ripple or spike is input to D/A converter upper reference voltage terminal (VrefU1,2), accuracy of D/A converter is down, So, when use this device, please connect capacitor among Vcc to GND for stable D/A conversion.
- This IC's output amplifier has an advantage to capacitive load, So, it's no problem at device action when connect capacitor ( 0.1  $\mu$ F Max ) among output to GND for every noise elimination.

### Application Example

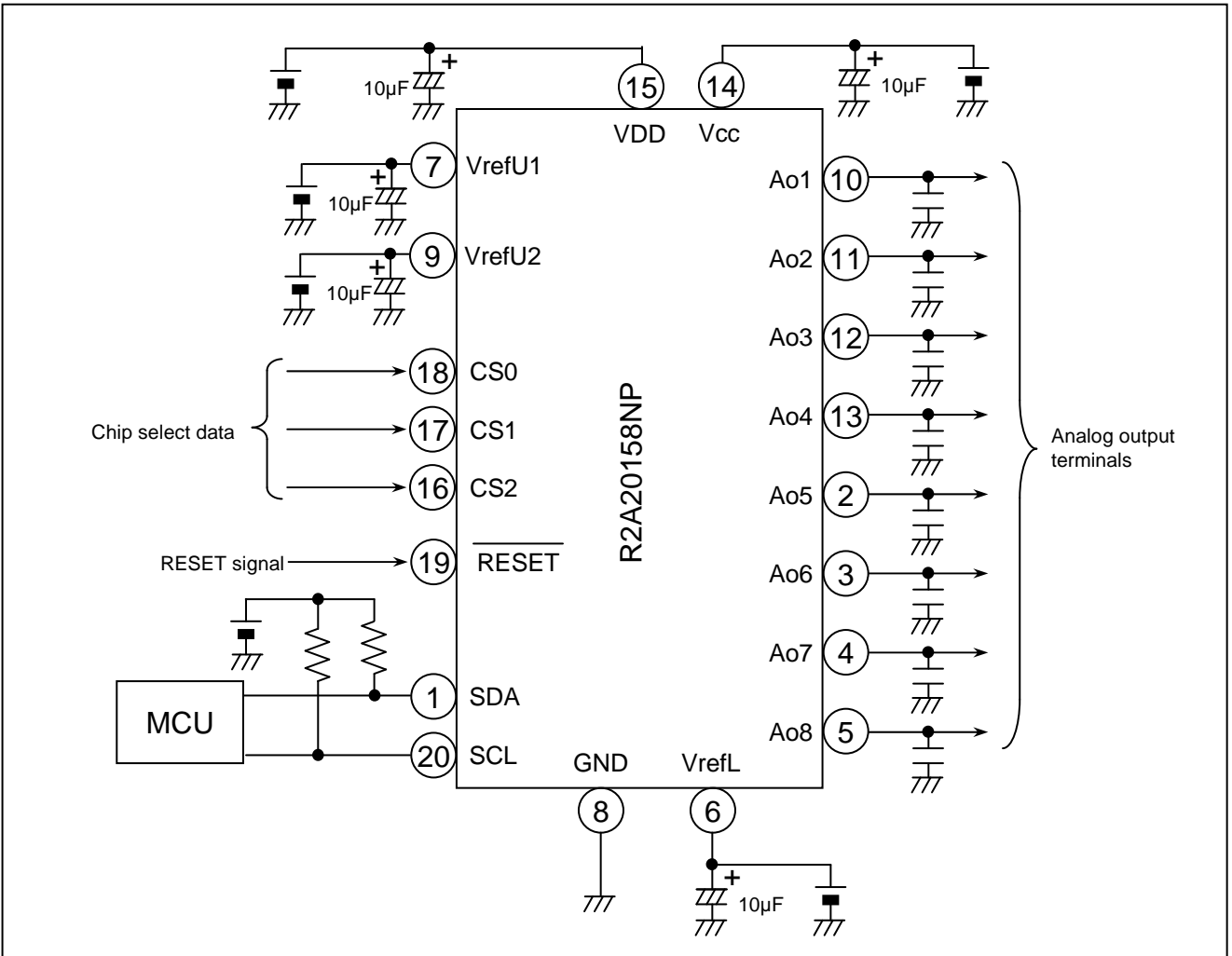

## Package Dimensions

### PWQN0020KB-A [NP]

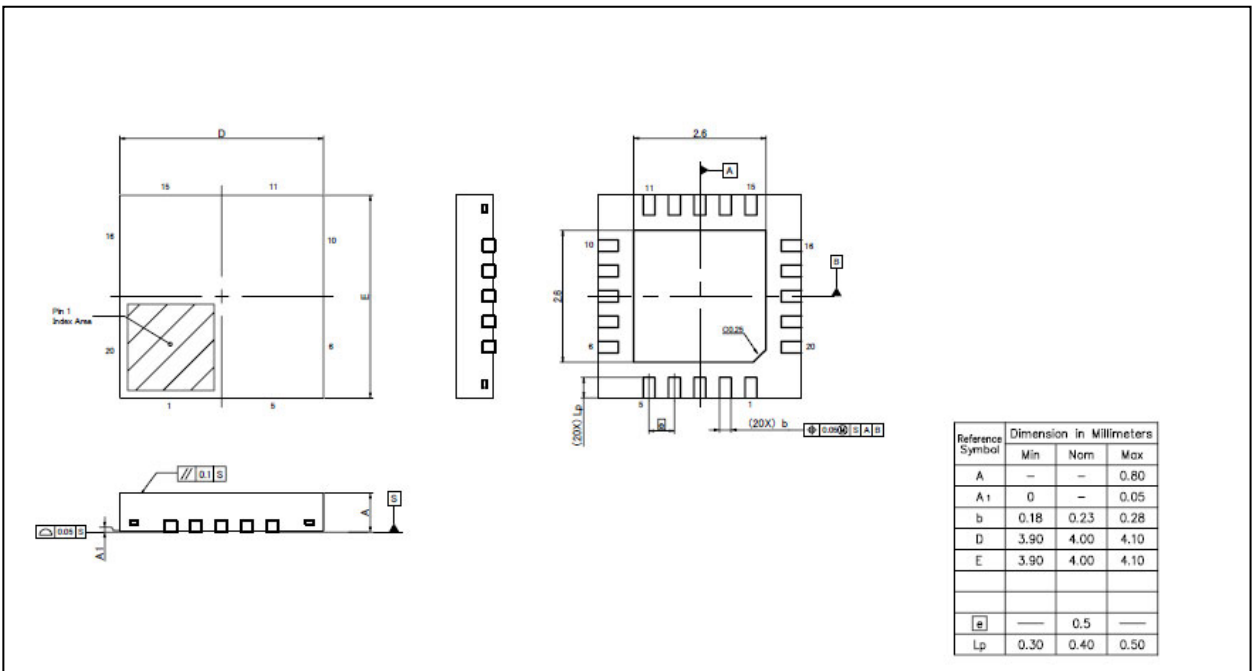

## Ordering Information

Order part No.	Package Name	Package Code	Package type No.	Packing/Quantity
R2A20158NP	QFN-20	PWQN0020KB-A	NP	Embossed Taping/2,500 pcs.



## Notice

- All information included in this document is current as of the date this document is issued. Such information, however, is subject to change without any prior notice. Before purchasing or using any Renesas Electronics products listed herein, please confirm the latest product information with a Renesas Electronics sales office. Also, please pay regular and careful attention to additional and different information to be disclosed by Renesas Electronics such as that disclosed through our website.
- Renesas Electronics does not assume any liability for infringement of patents, copyrights, or other intellectual property rights of third parties by or arising from the use of Renesas Electronics products or technical information described in this document. No license, express, implied or otherwise, is granted hereby under any patents, copyrights or other intellectual property rights of Renesas Electronics or others.
- You should not alter, modify, copy, or otherwise misappropriate any Renesas Electronics product, whether in whole or in part.
- Descriptions of circuits, software and other related information in this document are provided only to illustrate the operation of semiconductor products and application examples. You are fully responsible for the incorporation of these circuits, software, and information in the design of your equipment. Renesas Electronics assumes no responsibility for any losses incurred by you or third parties arising from the use of these circuits, software, or information.
- When exporting the products or technology described in this document, you should comply with the applicable export control laws and regulations and follow the procedures required by such laws and regulations. You should not use Renesas Electronics products or the technology described in this document for any purpose relating to military applications or use by the military, including but not limited to the development of weapons of mass destruction. Renesas Electronics products and technology may not be used for or incorporated into any products or systems whose manufacture, use, or sale is prohibited under any applicable domestic or foreign laws or regulations.
- Renesas Electronics has used reasonable care in preparing the information included in this document, but Renesas Electronics does not warrant that such information is error free. Renesas Electronics assumes no liability whatsoever for any damages incurred by you resulting from errors in or omissions from the information included herein.
- Renesas Electronics products are classified according to the following three quality grades: "Standard", "High Quality", and "Specific". The recommended applications for each Renesas Electronics product depends on the product's quality grade, as indicated below. You must check the quality grade of each Renesas Electronics product before using it in a particular application. You may not use any Renesas Electronics product for any application categorized as "Specific" without the prior written consent of Renesas Electronics. Further, you may not use any Renesas Electronics product for any application for which it is not intended without the prior written consent of Renesas Electronics. Renesas Electronics shall not be in any way liable for any damages or losses incurred by you or third parties arising from the use of any Renesas Electronics product for an application categorized as "Specific" or for which the product is not intended where you have failed to obtain the prior written consent of Renesas Electronics. The quality grade of each Renesas Electronics product is "Standard" unless otherwise expressly specified in a Renesas Electronics data sheets or data books, etc.  
"Standard": Computers; office equipment; communications equipment; test and measurement equipment; audio and visual equipment; home electronic appliances; machine tools; personal electronic equipment; and industrial robots.  
"High Quality": Transportation equipment (automobiles, trains, ships, etc.); traffic control systems; anti-disaster systems; anti-crime systems; safety equipment; and medical equipment not specifically designed for life support.  
"Specific": Aircraft; aerospace equipment; submersible repeaters; nuclear reactor control systems; medical equipment or systems for life support (e.g. artificial life support devices or systems), surgical implantations, or healthcare intervention (e.g. excision, etc.), and any other applications or purposes that pose a direct threat to human life.
- You should use the Renesas Electronics products described in this document within the range specified by Renesas Electronics, especially with respect to the maximum rating, operating supply voltage range, movement power voltage range, heat radiation characteristics, installation and other product characteristics. Renesas Electronics shall have no liability for malfunctions or damages arising out of the use of Renesas Electronics products beyond such specified ranges.
- Although Renesas Electronics endeavors to improve the quality and reliability of its products, semiconductor products have specific characteristics such as the occurrence of failure at a certain rate and malfunctions under certain use conditions. Further, Renesas Electronics products are not subject to radiation resistance design. Please be sure to implement safety measures to guard them against the possibility of physical injury, and injury or damage caused by fire in the event of the failure of a Renesas Electronics product, such as safety design for hardware and software including but not limited to redundancy, fire control and malfunction prevention, appropriate treatment for aging degradation or any other appropriate measures. Because the evaluation of microcomputer software alone is very difficult, please evaluate the safety of the final products or system manufactured by you.
- Please contact a Renesas Electronics sales office for details as to environmental matters such as the environmental compatibility of each Renesas Electronics product. Please use Renesas Electronics products in compliance with all applicable laws and regulations that regulate the inclusion or use of controlled substances, including without limitation, the EU RoHS Directive. Renesas Electronics assumes no liability for damages or losses occurring as a result of your noncompliance with applicable laws and regulations.
- This document may not be reproduced or duplicated, in any form, in whole or in part, without prior written consent of Renesas Electronics.
- Please contact a Renesas Electronics sales office if you have any questions regarding the information contained in this document or Renesas Electronics products, or if you have any other inquiries.  
(Note 1) "Renesas Electronics" as used in this document means Renesas Electronics Corporation and also includes its majority-owned subsidiaries.  
(Note 2) "Renesas Electronics product(s)" means any product developed or manufactured by or for Renesas Electronics.



### SALES OFFICES

Renesas Electronics Corporation

<http://www.renesas.com>

Refer to "<http://www.renesas.com/>" for the latest and detailed information.

**Renesas Electronics America Inc.**  
2880 Scott Boulevard Santa Clara, CA 95050-2554, U.S.A.  
Tel: +1-408-586-6000, Fax: +1-408-586-6130

**Renesas Electronics Canada Limited**  
1101 Nicholson Road, Newmarket, Ontario L3Y 9C3, Canada  
Tel: +1-905-898-5441, Fax: +1-905-898-3220

**Renesas Electronics Europe Limited**  
Dukes Meadow, Millboard Road, Bourne End, Buckinghamshire, SL8 5FH, U.K.  
Tel: +44-1628-585-100, Fax: +44-1628-585-900

**Renesas Electronics Europe GmbH**  
Arcadiastrasse 10, 40472 Düsseldorf, Germany  
Tel: +49-211-65030, Fax: +49-211-6503-1327

**Renesas Electronics (China) Co., Ltd.**  
7th Floor, Quantum Plaza, No.27 ZhiChunLu Haidian District, Beijing 100083, P.R.China  
Tel: +86-10-8235-1155, Fax: +86-10-8235-7679

**Renesas Electronics (Shanghai) Co., Ltd.**  
Unit 204, 205, AZIA Center, No.1233 Lujiazui Ring Rd., Pudong District, Shanghai 200120, China  
Tel: +86-21-5877-1818, Fax: +86-21-6887-7858 / -7898

**Renesas Electronics Hong Kong Limited**  
Unit 1601-1613, 16/F., Tower 2, Grand Century Place, 193 Prince Edward Road West, Mongkok, Kowloon, Hong Kong  
Tel: +852-2886-9318, Fax: +852 2886-9022/9044

**Renesas Electronics Taiwan Co., Ltd.**  
13F, No. 363, Fu Shing North Road, Taipei, Taiwan  
Tel: +886-2-8175-9600, Fax: +886 2-8175-9670

**Renesas Electronics Singapore Pte. Ltd.**  
1 HarbourFront Avenue, #06-10, Keppel Bay Tower, Singapore 098632  
Tel: +65-6213-0200, Fax: +65-6276-8001

**Renesas Electronics Malaysia Sdn.Bhd.**  
Unit 906, Block B, Menara Amcorp, Amcorp Trade Centre, No. 18, Jln Persiaran Barat, 46050 Petaling Jaya, Selangor Darul Ehsan, Malaysia  
Tel: +60-3-7955-9390, Fax: +60-3-7955-9510

**Renesas Electronics Korea Co., Ltd.**  
11F., Samik Lavied' or Bldg., 720-2 Yeoksam-Dong, Kangnam-Ku, Seoul 135-080, Korea  
Tel: +82-2-558-3737, Fax: +82-2-558-5141