

Cell Type NBL414R Specifications

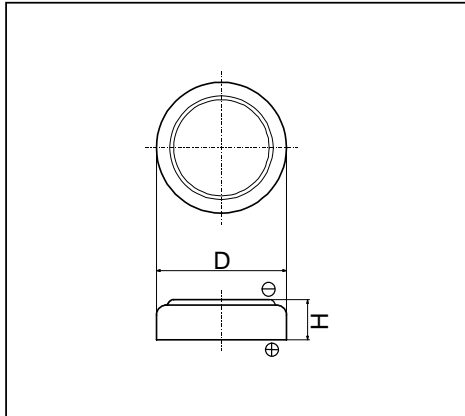

Nominal Capacity ^{*1}		0.5mAh
Nominal Voltage		2V
Standard Charge / Discharge Current		0.005mA
Max. Discharge Current	Continuous ^{*2}	0.02mA
	Pulse ^{*3}	0.05mA
Charge/Discharge Cycle Characteristics	Discharging Depth of 5%	3000
	Discharging Depth of 10%	300
Charging Method		Constant Voltage Charge
Temperature Range		-20 ~ 60
Weight		0.08g
Dimensions	Diameter(D)	4.8mm
	Height(H)	1.4mm
Max. Reflow Temperature		260

*1 Nominal capacity is determined to an end voltage of 1.0V when the battery is allowed to discharge at a standard current level at 23°C.

*2 Current value is determined so that 50% of the nominal capacity is obtained with an end voltage of 1.0V at 23 °C.

*3 Current value for obtaining 1.0V cell voltage when 15sec. pulse is applied at 50% discharge depth at 23 °C.

* NBL414R is capable of reflow soldering. Consult Sanyo about the reflow condition.

Typical Characteristics

Charge Characteristics of NBL414R

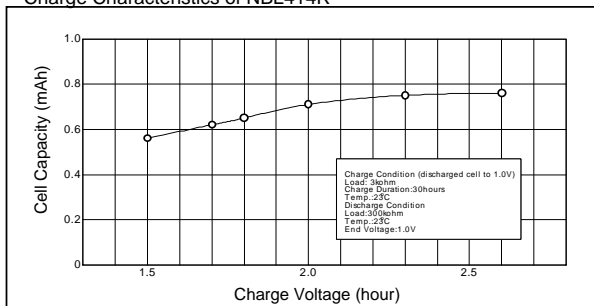

Temperature Characteristics of NBL414R

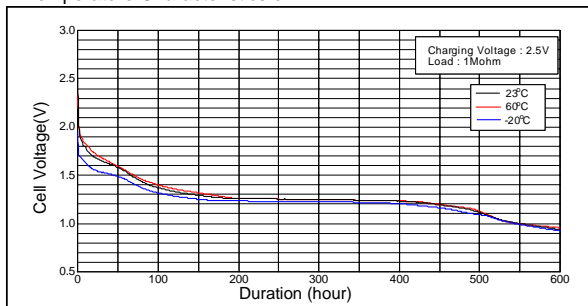

Discharge/Discharge Cycle Characteristics of NBL414R

