

Power Bead > 2A, RAC@100 MHz = 70 ohm, RDC(max)= 0.4 ohm

**SUNPLUS**

POWER & CONNECTOR

Document Number: **8202L-16-64M-SY-128-0-C**

Date: Monday, January 22, 2007 Sheet 1 of 6

Rev: 1.02



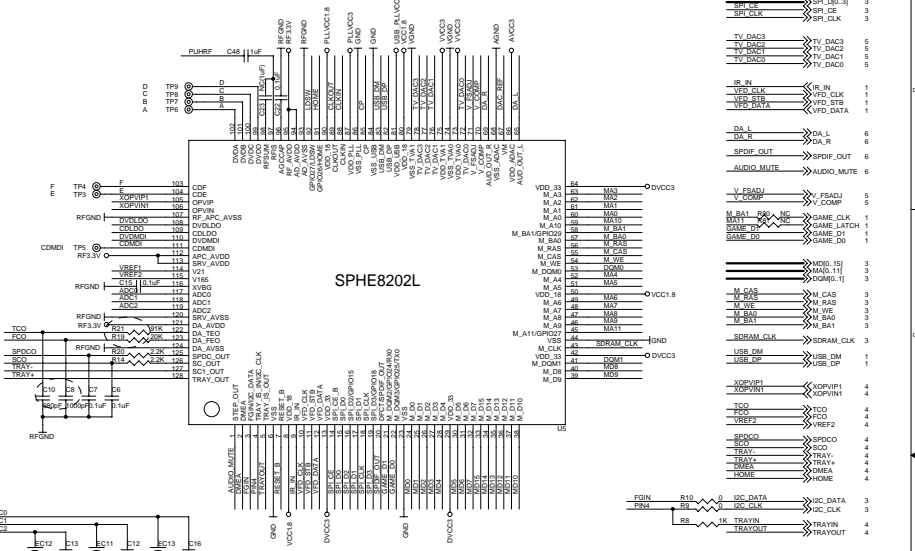
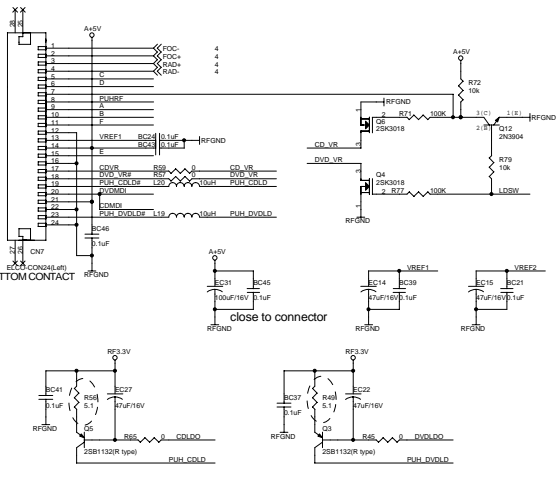

Pickup head parameter		VR电阻		TCO		FCO		
OPU	Mecha	Motor Driver	R59	R57	R21	C10	R19	C8
Santo HD65	DV34 clones	AM5888	0R	0R	91K	680P	20K	1000P
Santo HD65	Foryou DL-05	AM5668	0R	0R	91K	680P	20K	1000P
Samsung	Samsung S76	AM5668	0R	0R	68K	1000P	20K	1000P
Samsung	DV34 clones	AM5668	0R	0R	68K	1000P	20K	1000P
SONY KHM-313	SONY KHM-313	AM5668	100R	100R	91K	680P	20K	1000P
Mitsumi 502W	DeChang ZB-101	AM5668	0R	0R	91K	680P	20K	1000P

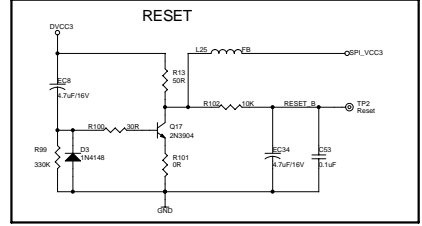
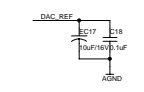
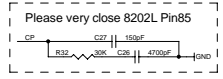
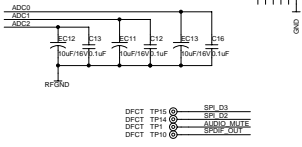
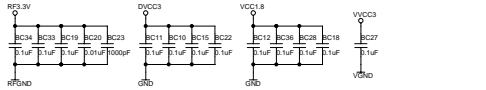

**SUNPLUS**  
**SPHE8202L**  
 8202L-16-64M-SY-128-0-C Rev 1.02  
 Date: Monday, January 29, 2007 Page 2 of 6

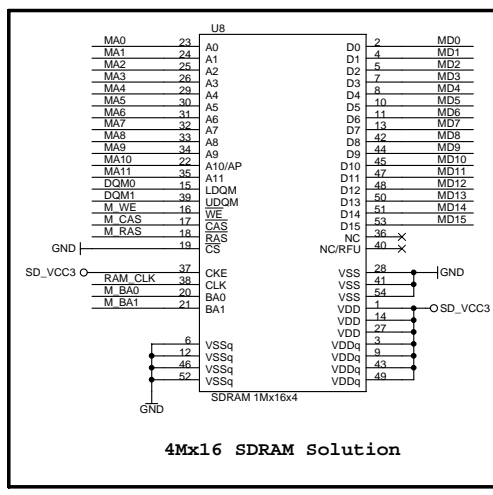
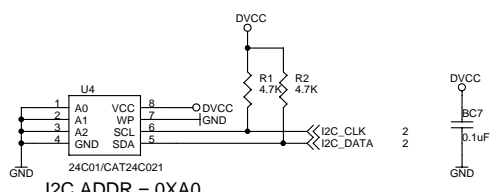
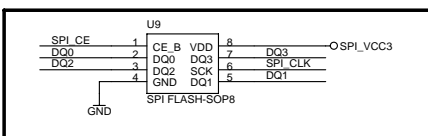
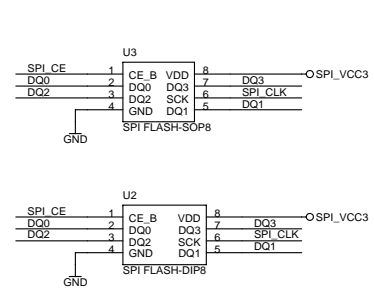
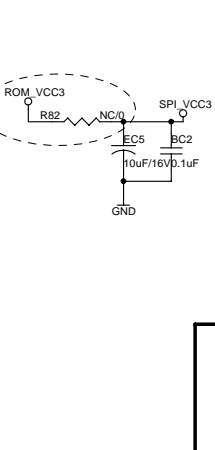
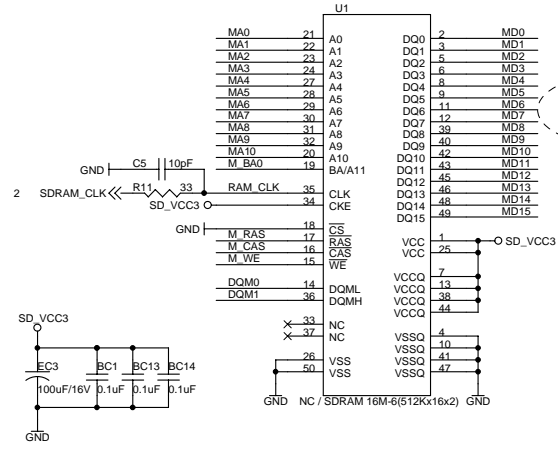

4Mx16 SDRAM Solution

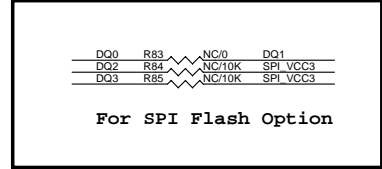
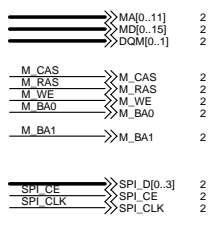

For SPI Flash Option

**SUNPLUS**

Title: **SDRAM / SPI FLASH / EEPROM**

Size: Document Number **8202L-16-64M-SY-128-0-C** Rev **1.02**

Date: Monday, January 22, 2007 Sheet 3 of 6

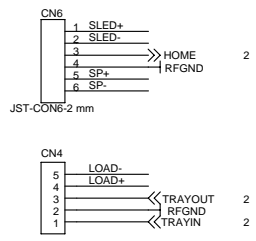
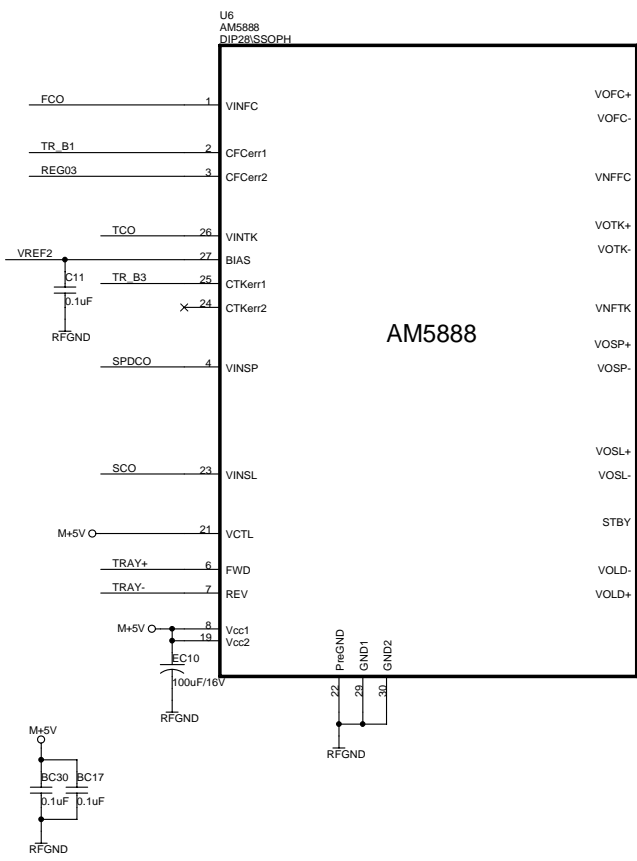

FOC+	FOC+	2
FOC-	FOC-	2
RAD+	RAD+	2
RAD-	RAD-	2
TCO	TCO	2
FCO	FCO	2
SCO	SCO	2
SPDCO	SPDCO	2
TRAY-	TRAY-	2
TRAY+	TRAY+	2
DMEA	DMEA	2
TRAYOUT	TRAYOUT	2
TRAYIN	TRAYIN	2
HOME	HOME	2
XOPVIP1	XOPVIP1	2
XOPVIN1	XOPVIN1	2
VREF2	VREF2	2
TR_B1	TR_B1	1
TR_B3	TR_B3	1
REG01	REG01	1
REG03	REG03	1

**SUNPLUS**

Title: **MOTOR-DRIVER**

Size: Document Number

**8202L-16-64M-SY-128-0-C**

Date: Monday, January 22, 2007

Rev: **1.02**

Sheet 4 of 6

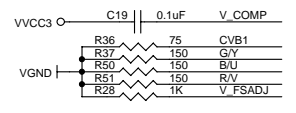
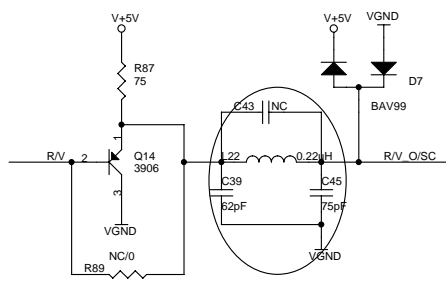
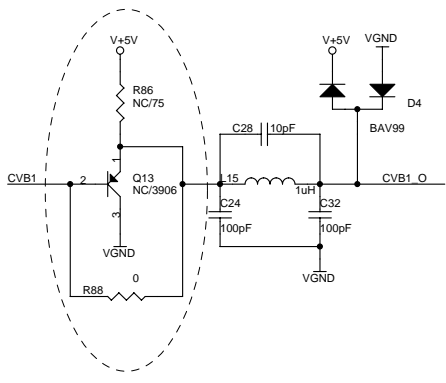

TV0	TV1	TV2	TV3
CVB	Y	Cb	Cr
CVB	Y(S-Video)	CVB	C(S-Video)
CVB	G	B	R

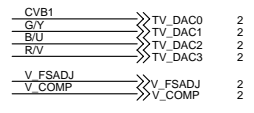
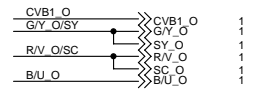
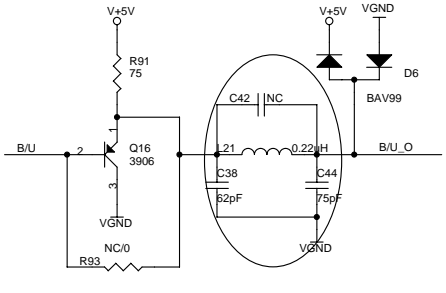
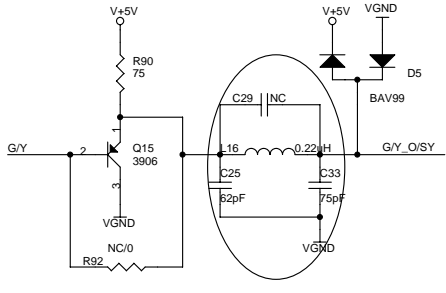

**SUNPLUS**

Title: **VIDEO BUFFER**

Size: Document Number **8202L-16-64M-SY-128-0-C** Rev **1.02**

Date: Monday, January 22, 2007 Sheet 5 of 6

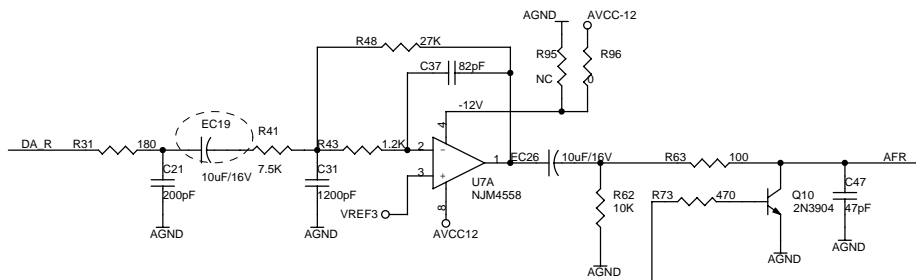

EC18 EC19极性，图中OP采用双电源供电，  
若OP采用单电源供电，EC18 EC19极性需对调

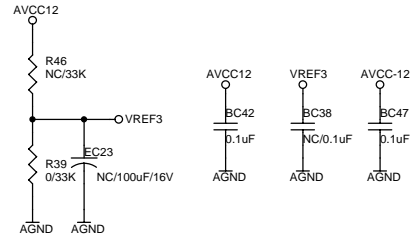
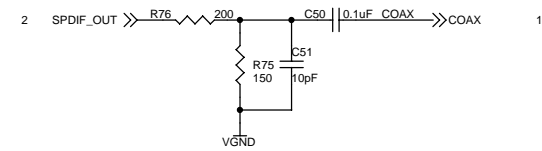
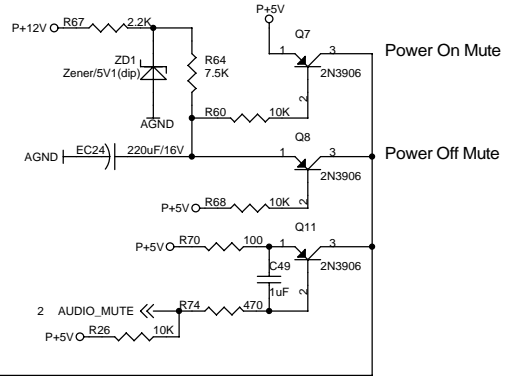
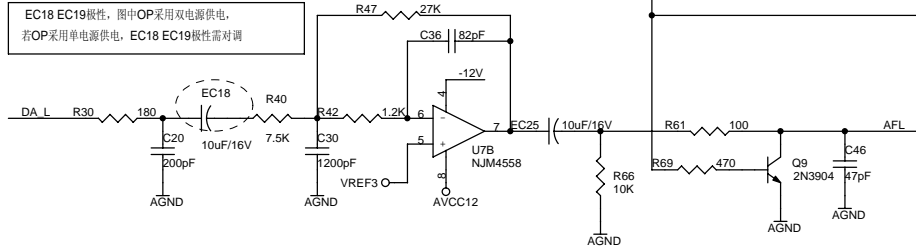

**SUNPLUS**

Title: **AUDIO FILTER**

Size: Document Number: **8202L-16-64M-SY-128-0-C** Rev: **1.02**

Date: Monday, January 22, 2007 Sheet 6 of 6