

- Low saturation voltage.
 (Typical 1.35V at load current 0.5A and no bootstrap condition.)
 - Absolute maximum rating of load current : CH1~5 500mA
 By taking advantage of the bootstrap function,
 the saturation voltage can be lower.
 - There are two motor power supplies.
 Vm1 CH1,2 motor power supply-1
 Vm2 CH3,4,5 motor power supply-2
 - Built-in OP amp. for Regulator.
 (It enables a Regulator which consists of external PNP Tr.s
 and resistors.)
 - Flexible Input amp. setting.(It enables PWM control.)
 - Low cross-over distortion.
 - Wide supply voltage range.(4.5V ~13.2V)
 - Built-in Thermal Shut Down circuit.
 - Built-in Mute circuit.(two systems)
- MUTE1: CH1~4, MUTE2: CH5

PIN CONFIGURATION (TOPVIEW)

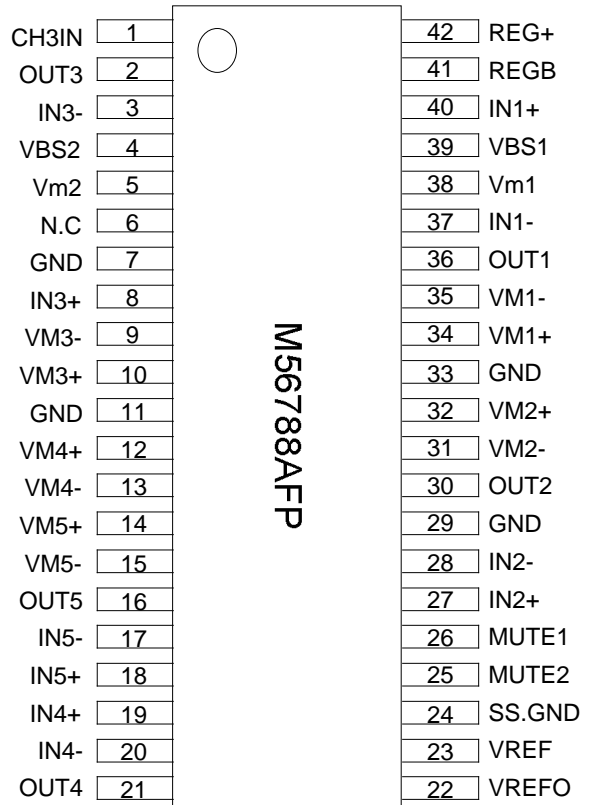

42pin POWER SSOP (42P9R-K)

MD,CD-audio,CDROM,VCD,DVD etc.

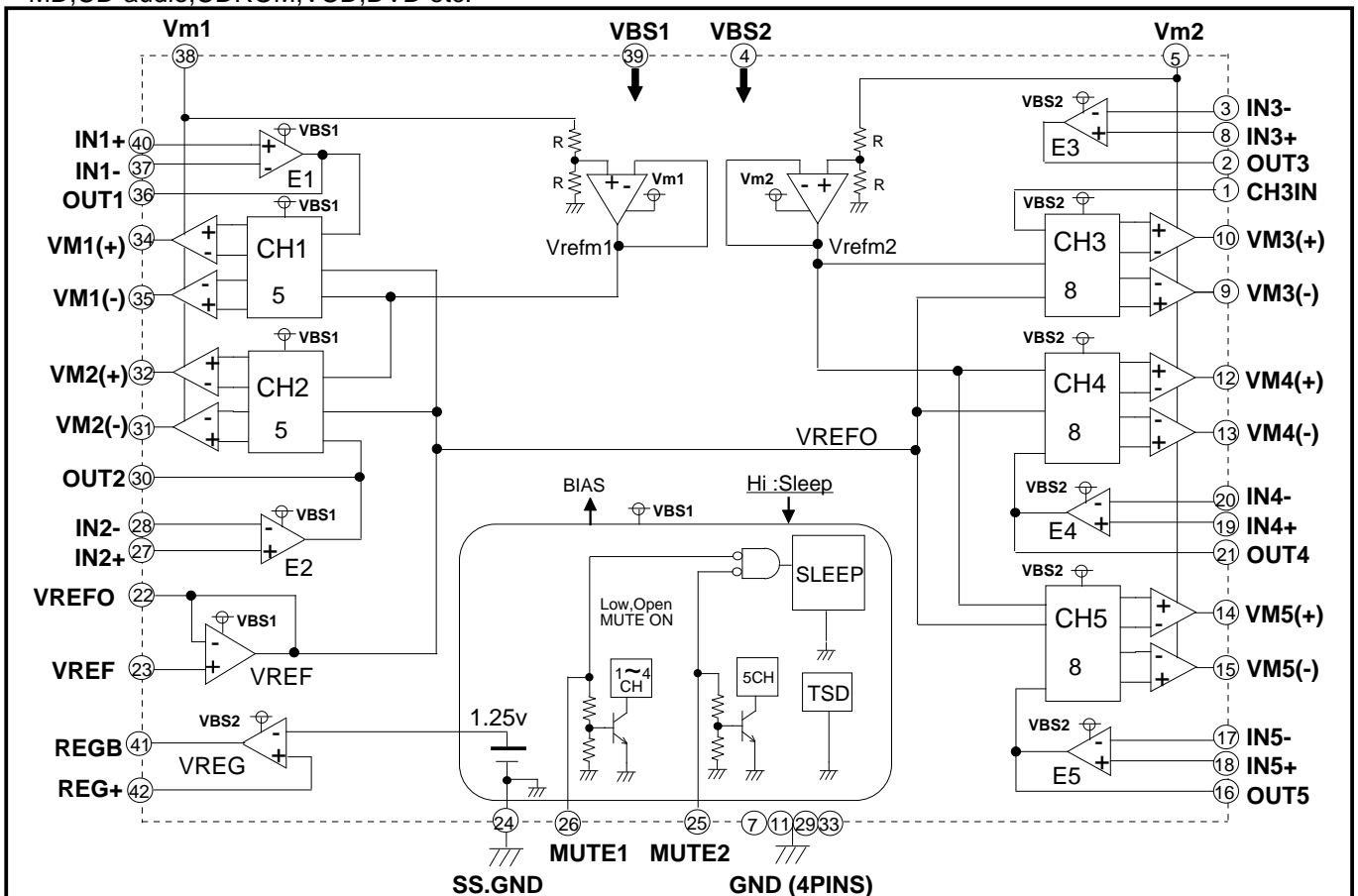

<PIN FUNCTION>

TERMINAL	SYMBOL	TERMINAL FUNCTION	TERMINAL	SYMBOL	TERMINAL FUNCTION
1	CH3IN	CH3 non-inverted input	42	REG+	Regulator voltage setting resistor
2	OUT3	E3 amplifier output	41	REGB	Regulator PNP base connect
3	IN3-	E3 amplifier inverted input	40	IN1+	E1 amplifier non-inverted input
4	VBS2	Bootstrap power supply	39	VBS1	Bootstrap power supply
5	Vm2	Motor power supply	38	Vm1	Motor power supply
6	N.C	N.C	37	IN1-	E1 amplifier inverted input
7,11	GND	Motor GND	36	OUT1	E1 amplifier output
8	IN3+	E3 amplifier non-inverted input	35	VM1(-)	CH1 inverted output
9	VM3(-)	CH3 inverted output	34	VM1(+)	CH1 non-inverted output
10	VM3(+)	CH3 non-inverted output	29,33	GND	Motor GND
12	VM4(+)	CH4 non-inverted output	32	VM2(+)	CH2 non-inverted output
13	VM4(-)	CH4 inverted output	31	VM2(-)	CH2 inverted output
14	VM5(+)	CH5 non-inverted output	30	OUT2	E2 amplifier output
15	VM5(-)	CH5 inverted output	28	IN2-	E2 amplifier inverted input
16	OUT5	E5 amplifier output	27	IN2+	E2 amplifier non-inverted input
17	IN5-	E5 amplifier inverted input	26	MUTE1	CH1~4 mute
18	IN5+	E5 amplifier non-inverted input	25	MUTE2	CH5 mute
19	IN4+	E4 amplifier non-inverted input	24	SS.GND	Small signal GND
20	IN4-	E4 amplifier inverted input	23	VREF	Reference voltage input
21	OUT4	E4 amplifier output	22	VREF0	Reference voltage output

<ABSOLUTE MAXIMUM RATING> (Ta=25°C)

SYMBOL	PARAMETER	CONDITIONS	RATING	Units
VBS	Bootstrap power supply	VBS power supply	15	V
Vm	Motor power supply	Vm power supply	15	V
Io	Output Current		500	mA
Vin	Maximum input voltage of terminals	23,25,26,27,28,37,40PIN	0 ~ VBS1	V
		1,3,8,17,18,19,20,42PIN	0 ~ VBS2	V
Pt	Power dissipation	Free Air	1.2	W
K	Thermal derating	Free Air	9.6	mW / °C
Tj	Junction temperature		150	°C
Topr	Operating temperature		-20 ~ +75	°C
Tstg	Storage temperature		-40 ~ +150	°C

<THERMAL DERATING>

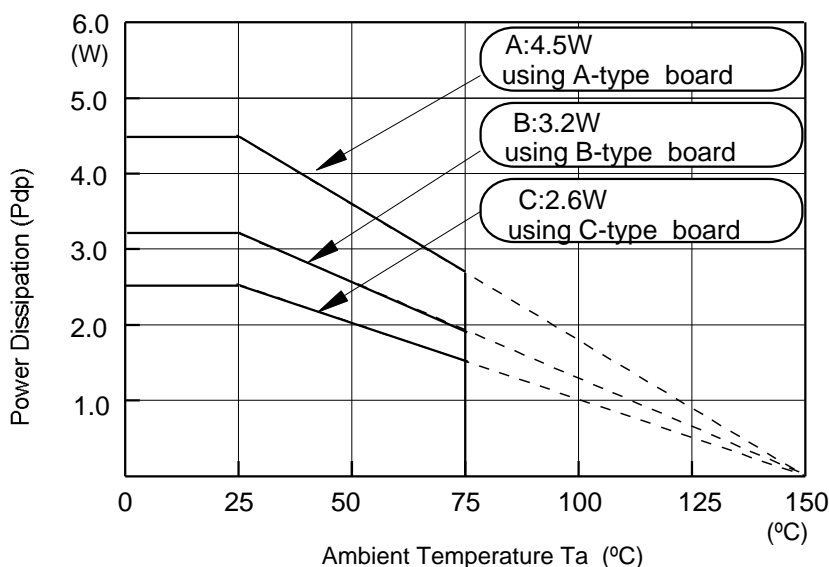

This IC's package is POWER-SSOP, so improving the board on which the IC is mounted enables a large power dissipation without a heat sink.

For example, using an 1 layer glass epoxy resin board, the IC's power dissipation is 2.6W at least. And it comes to 4.5W by using an improved 2 layer board.

The information of the A, B, C type board is shown on page 8.

<RECOMMENDED OPERATING CONDITIONS>

SYMBOL	PARAMETER	LIMITS			Units
		minimum	typical	maximum	
Vm1,Vm2	Motor power supply		5.0		V
VBS1,VBS2	Bootstrap power supply		Vm *+ 1.0		V

<ELECTRICAL CHARACTERISTICS>

(Ta=25°C, VBS=Vm=5V unless otherwise noted.)

SYMBOL	PARAMETER	CONDITIONS	LIMITS			Units
			MIN	TYP	MAX	
Icc1	Supply current - 1	VBS1,VBS2,Vm1,Vm2 current	—	35	50	
Icc2	Supply current - 2	VBS1,VBS2,Vm1,Vm2 current at Sleep Mode (MUTE1 = MUTE 2 =0V).	—	1.3	2.2	mA
Vsat1	CH1~5 Saturation voltage	Top and Bottom saturation voltage. Load current 0.5A and no bootstrap.	—	1.35	1.9	V
Voff1	CH1 output offset voltage	VREFO=OUT1=1.5V	-41	—	41	mV
Voff2	CH2 output offset voltage	VREFO=OUT2=1.5V	-41	—	41	mV
Voff3	CH3 output offset voltage	VREFO=CH3IN=1.5V	-47	—	47	mV
Voff4	CH4 output offset voltage	VREFO=OUT4=1.5V	-47	—	47	mV
Voff5	CH5 output offset voltage	VREFO=OUT5=1.5V	-47	—	47	mV
Gain1	CH1 Voltage Gain between input and output	{VM1(+)-VM1(-)} (OUT1-VREFO)	4.5	5	5.5	V/V
Gain2	CH2 Voltage Gain between input and output	{VM2(+)-VM2(-)} (OUT2-VREFO)	4.5	5	5.5	V/V

<ELECTRICAL CHARACTERISTICS>

(Ta=25°C, VBS=Vm=5V unless otherwise noted.)

SYMBOL	PARAMETER	CONDITIONS	LIMITS			Units
			MIN	TYP	MAX	
Gain3	CH3 Voltage Gain between input and output	{VM3(+)-VM3(-)} (CH3IN-VREFO)	7.2	8	8.8	V/V
Gain4	CH4 Voltage Gain between input and output	{VM4(+)-VM4(-)} (OUT4-VREFO)	7.2	8	8.8	V/V
Gain5	CH5 Voltage Gain between input and output	{VM5(+)-VM5(-)} (OUT5-VREFO)	7.2	8	8.8	V/V
VinE	E1,2,3,4,5 amplifier input voltage range	E1,E2 amp	0.5	—	VBS1-2.0	V
		E3,E4,E5 amp	0.5	—	VBS2-2.0	V
VoutE	E1,2,3,4,5 amplifier output voltage range	E1,E2 amp (no load)	0.5	—	VBS1-0.5	V
		E3,E4,E5 amp (no load)	0.5	—	VBS2-0.5	V
VofE	E1,2,3,4,5 amplifier offset voltage	Vin = 1.5V(at buffer)	-10	—	+10	mV
linE	E1,2,3,4,5 amplifier input current	IN+ = IN- = 1.5V	-1.0	-0.05	0	μA
Reg-out	Regulator output voltage range	At VBS=7.5V, Regulator voltage setting resistor 10K/29.7K , connects external PNP.	4.8	5.0	5.2	V
VinVREF	VREF amplifier input voltage range		1.0	—	VBS1-2.0	V
VofVREF	VREF amplifier offset voltage	Vin= 1.5V ±2mA load	-10	—	+10	mV
linVREF	VREF amplifier input current	VREF= 1.5V	-1.0	-0.05	0	μA
Vmute-on	Mute-on voltage	Mute-on	—	—	0.8	V
Vmute-off	Mute-off voltage	Mute-off	2.0	—	—	V
Imute	Mute terminal input current	Mute terminal input current (at 5V input voltage)	—	170	250	μA

<MUTE Function.>

M56788AFP has 2 MUTE terminals and the functions are as follows.

MUTE 1 26 pin	MUTE 2 25 pin	Power and Control Amp. circuits of CH1 to CH4.	Power and Control Amp. circuits of CH5.	VREF Amp.	VREG Amp.
High	High	ENABLE	ENABLE	ENABLE	ENABLE
Low/Open	High	DISABLE	ENABLE	ENABLE	ENABLE
High	Low/Open	ENABLE	DISABLE	ENABLE	ENABLE
Low/Open	Low/Open	DISABLE	DISABLE	DISABLE	ENABLE

When both MUTE1 inputs and MUTE 2 inputs are low voltage or open, the IC is in Sleep Mode.

[THERMAL CHARACTERISTICS]

SYMBOL	PARAMETER	FUNCTION START TEMPERATURE OF IC			FUNCTION STOP TEMPERATURE OF IC			Unit
		MIN	TYP	MAX	MIN	TYP	MAX	
TSD	Thermal Shut Down	—	155	—	—	120	—	°C

*note

This TSD function start temperature doesn't show the guaranteed max. temperature of the devices.

The guaranteed max. temperature is Tj max. which is shown in "ABSOLUTE MAXIMUM RATING". The TSD function is a thermal protection in case the temperature of the devices goes up above Tjmax because of wrong use.

And these TSD temperature are the target temperatures for circuit design, not the guaranteed temperatures.

(The TSD function of all the devices is not checked by a test in high temperature.)

<INPUT and OUTPUT CHARACTERISTICS of EACH CHANNELS>

CH1,2

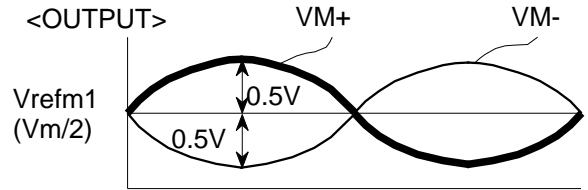
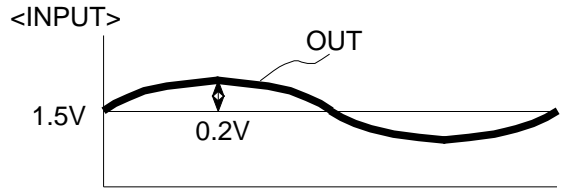
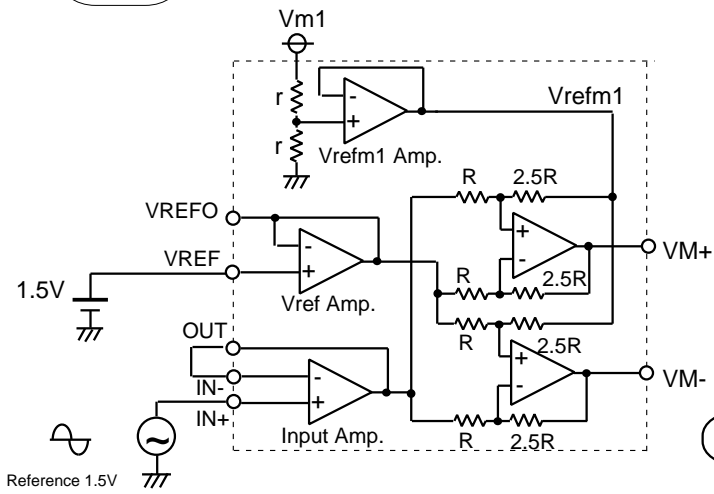

Gain = 5

CH3

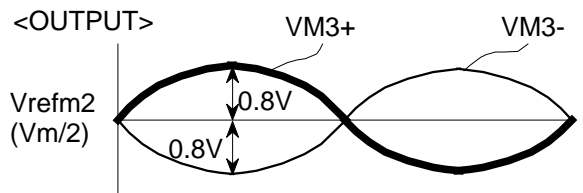
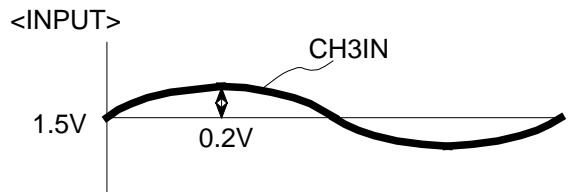
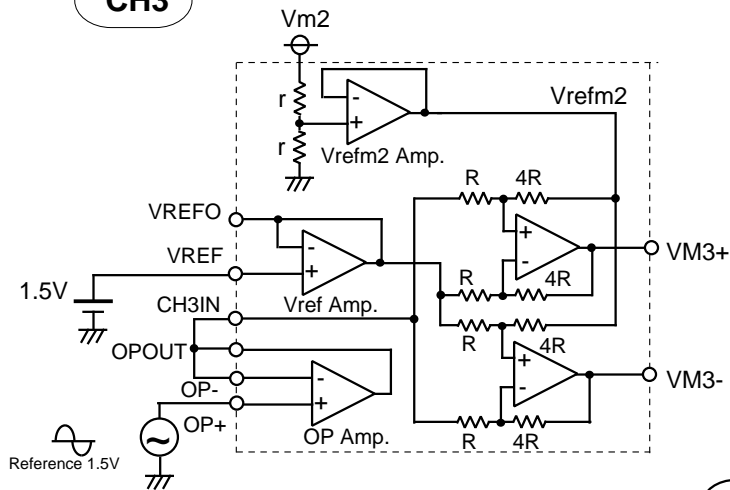

Gain = 8

CH4,5

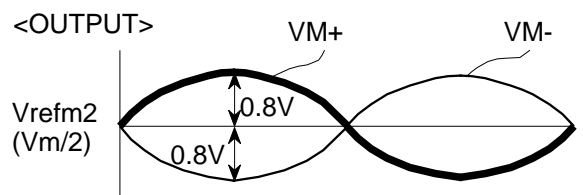
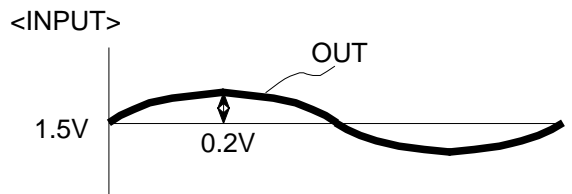
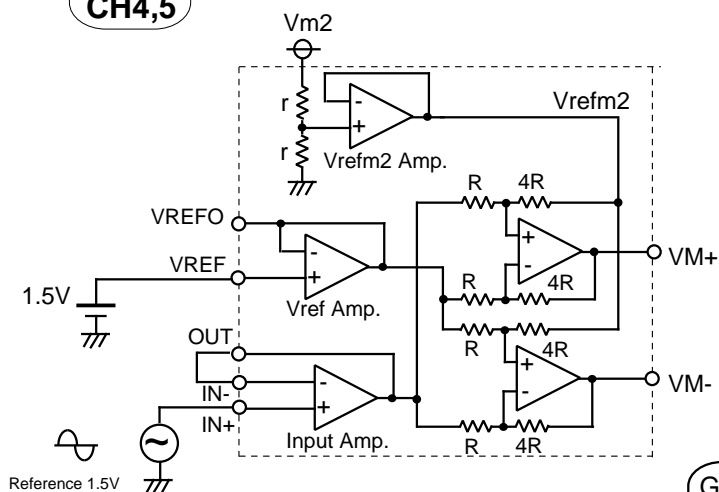

Gain = 8

< I/O terminal Equivalent circuit >

(1) E1, E2 input amplifier
 I/O terminal equivalent circuit

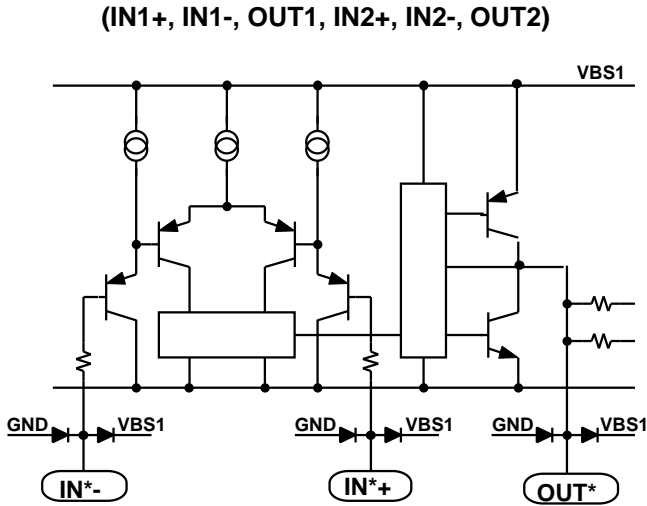

(2) E3, E4, E5 input amplifier
 I/O terminal equivalent circuit

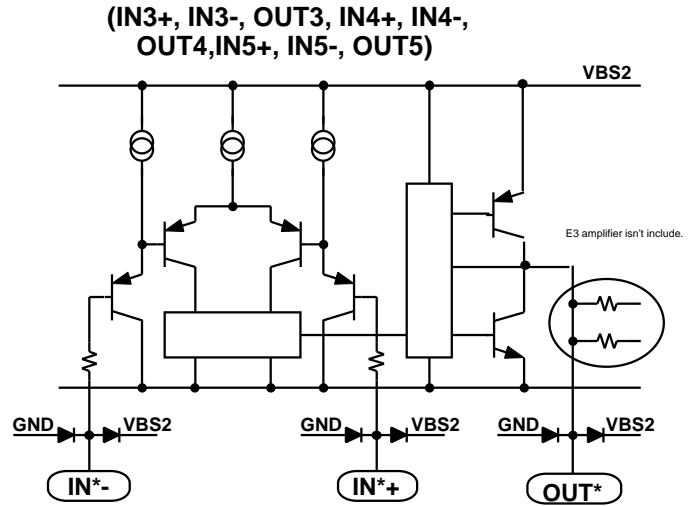

(3) VREF amplifier I/O terminal
 equivalent circuit

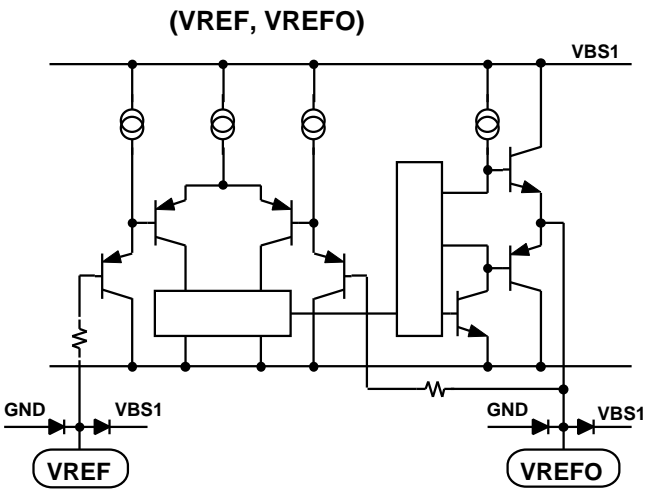

(4) VREG amplifier I/O terminal
 equivalent circuit

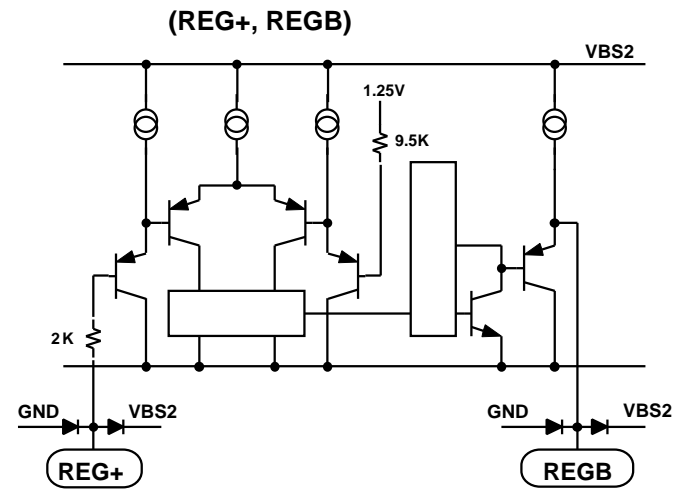

(5) CH3IN input terminal equivalent
 circuit

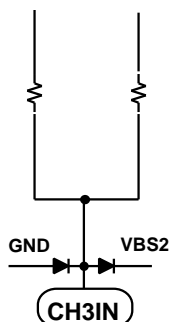

(6) MUTE equivalent circuit
 (MUTE1, MUTE2)

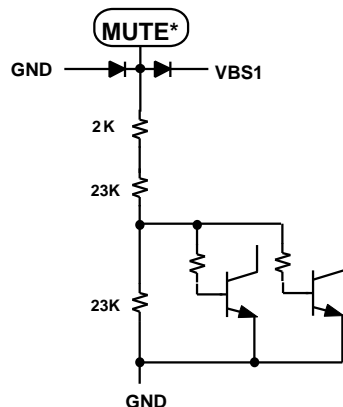

Please refer to the application circuits.
 (It shows the circuitry of the IC.)

<I/O terminal equivalent circuit >

(7) CH1,CH2 power I/O terminal equivalent circuit

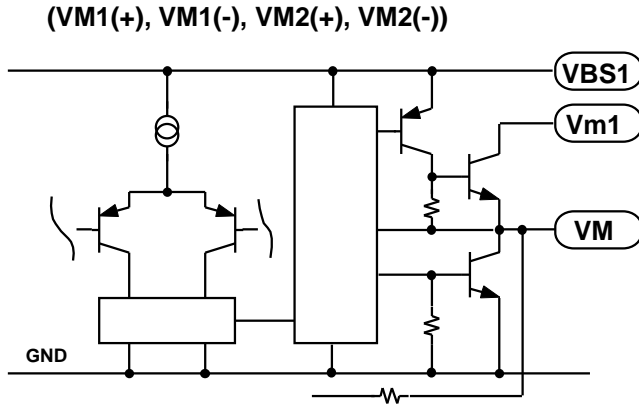

The equivalent circuits of an output stage of power amplifiers are shown in (7) and (8). The power supplies of CH1,CH2 are V_{m1} . And the power supplies of CH3, CH4, CH5 are V_{m2} . The source side of the power amplifier output stage consists of a PNP and a NPN. In the case of the CH1 and CH2, the emitta of the PNP is connected to V_{BS1} , and in the case of the CH3, CH4 and CH5, it is connected to V_{BS2} . So the power supplies of the PNP can be adjusted externally.

(8) CH3,CH4,CH5 power amplifier output terminal equivalent circuit

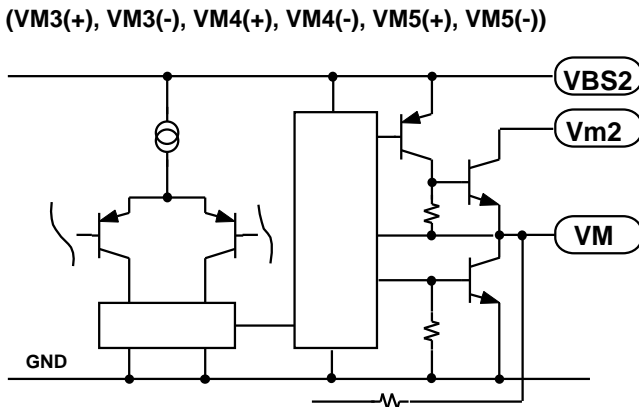

[About bootstrap advantage]

The output stage of the power amplifier consists of the preceding components. If V_{BS}^* is provided with higher voltage input than V_{m}^* (The recommendation voltage is V_{m}^*+1V) externally, the output range can be wider than that of $V_{BS}^*=V_{m}^*$.

Please take advantage of this bootstrap function for the system which has many power supplies. And it is the same with the external bootstrap circuit which provides V_{BS}^* with higher voltage inputs than V_{m}^* .

Also the bootstrap can decrease the saturation voltage at the source side of the power amplifier output stage. Therefore, when the outputs of the power amplifiers which drive motors and actuators are fully swung, the power dissipation of the IC will be decreased.

The boards for thermal derating evaluation

Board material
 Glass-epoxy FR-4
 Size
 70 70mm
 thickness
 t=1.6mm
 1 and 2 layers
 material : copper
 thickness:t=18μm

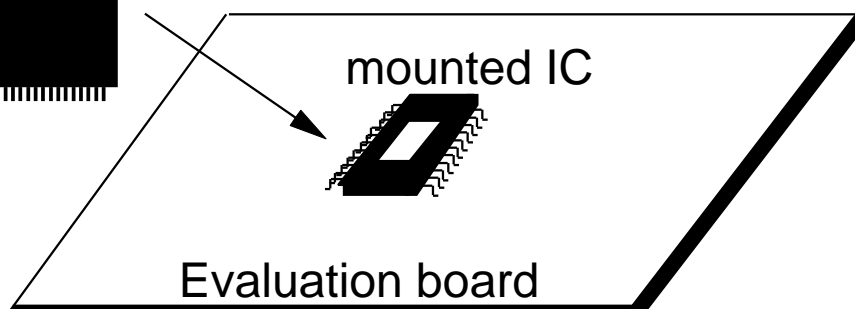
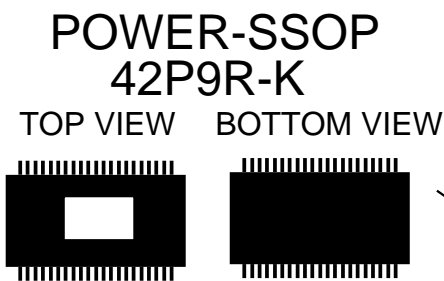
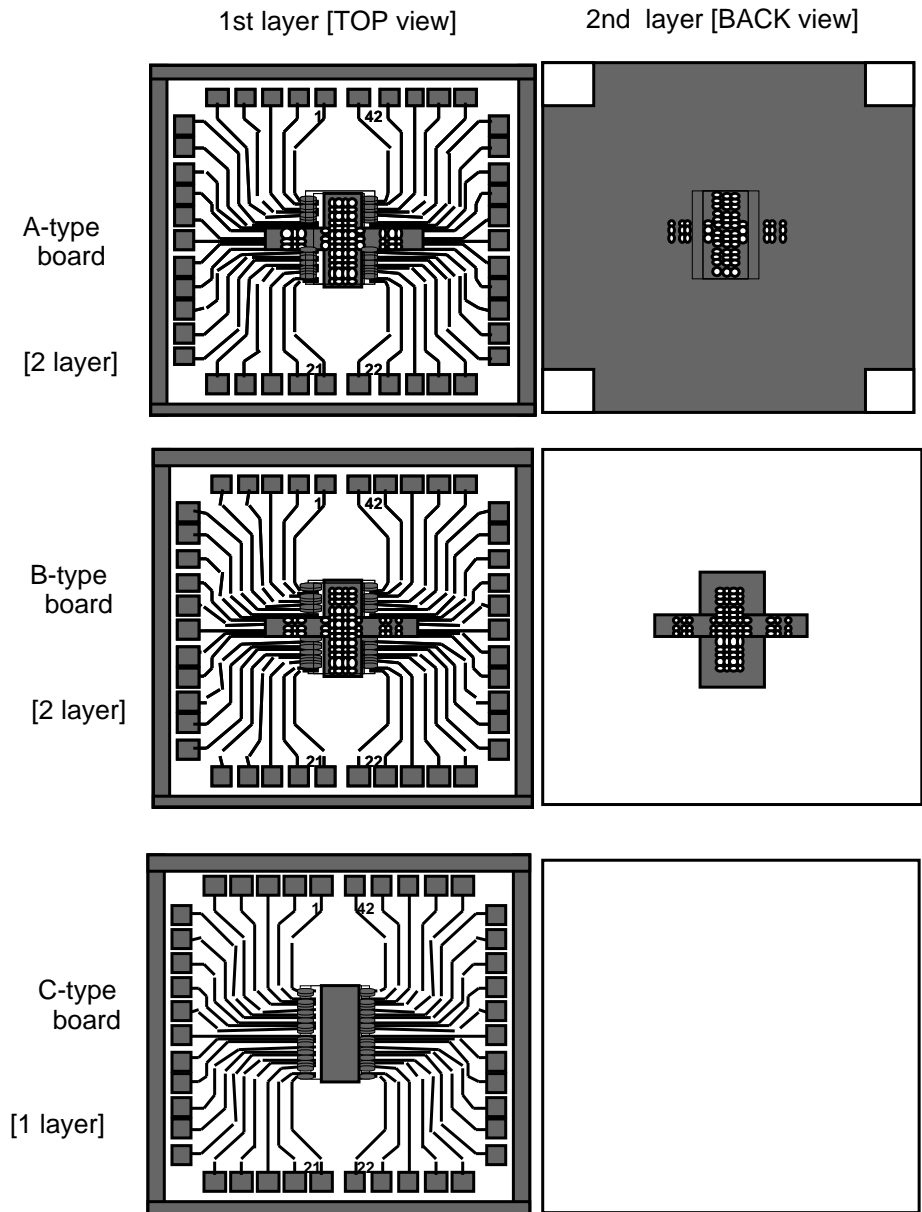

<APPLICATION CIRCUIT no.1>

single input (linear signal) Direct voltage control

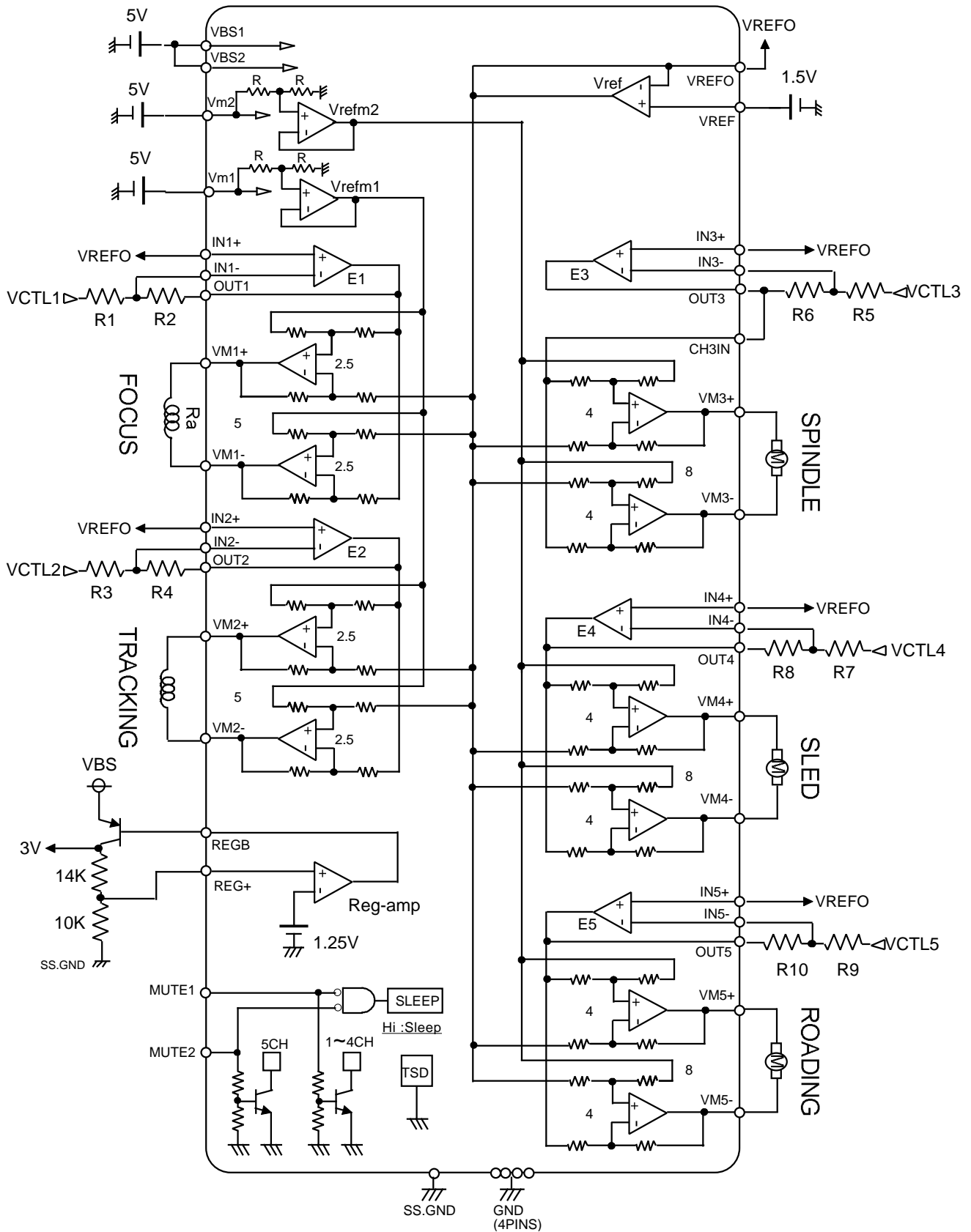

<APPLICATION CIRCUIT no.2>

Differential PWM input/Direct voltage control (FOCUS, TRACKING , SPINDLE, SLED, ROADING)

