



TAI-SAW TECHNOLOGY CO., LTD.

No. 3, Industrial 2nd Rd., Ping-Chen Industrial District,
Taoyuan, 324, Taiwan, R.O.C.

TEL: 886-3-4690038 FAX: 886-3-4697532

E-mail: tstsales@mail.taisaw.com Web: www.taisaw.com

Approval Sheet For Product Specification

Issued Date:

Product Name: SAW IF Filter 43.75MHz for Digital Cable TV

TST Parts No.: TB0182A

Customer Parts No.: _____

Company: _____
Division: _____
Approved by : _____
Date: _____

Checked by: _____ Kazuma Lee 

Approval by: _____ Francis Chen 

Date: _____ 12/15/2008



TAI-SAW TECHNOLOGY CO., LTD.

No. 3, Industrial 2nd Rd., Ping-Chen Industrial District,
Taoyuan, 324, Taiwan, R.O.C.

TEL: 886-3-4690038 FAX: 886-3-4697532

E-mail: tstsales@mail.taisaw.com Web: www.taisaw.com

IF SAW Filter 43.75 MHz

MODEL NO.: TB0182A

REV. NO.:4

A. FEATURES:

1. IF Filter for Digital Cable TV

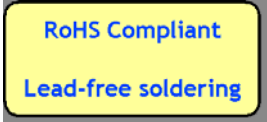

B. MAXIMUM RATING:

1. DC voltage: 12 V.

2. AC voltage: 10 V.

3. Storage Temperature: -40°C to +85 °C.

4. Operating Temperature: -25 °C to +65 °C

Terminating source impedance $Z_S=50\Omega$

Terminating load impedance $Z_L=2k\Omega//3\text{ pF}$

C. ELECTRICAL CHARACTERISTICS:

Attenuation (ref. : 43.75 MHz):

	MIN.	TYP.	MAX.	
Center frequency f_c				
Center frequency between 3dB point	43.68	43.75	43.82	MHz
Insertion attenuation				
Reference level for the Following data 43.75 MHz	13.5	15.0	16.5	dB
3dB Pass Bandwidth	-	6.0	-	MHz
30dB Pass Bandwidth	-	7.6	-	MHz
41.22 MHz	-1.0	0.2	1.4	dB
46.28 MHz	-1.0	0.2	1.4	dB
40.75 MHz	1.2	2.7	4.2	dB
46.75 MHz	1.2	2.7	4.2	dB
39.75 MHz	38.0	53.0	-	dB
47.75 MHz	37.0	48.0	-	dB
Lower side lobe				
35.00-39.00 MHz	42.0	48.0	-	dB
39.00-39.75 MHz	37.0	46.0	-	dB
Upper side lobe				
47.75-50.00 MHz	36.0	41.0	-	dB
50.00-55.00 MHz	42.0	48.0	-	dB
Reflected Wave Signal Suppression	42.0	52.0		dB
Feed through Signal Suppression	50.0	56.0		dB
Group delay ripple				
40.75-46.75 MHz	-	40	-	ns

Impedance at 43.75 MHz				
Input Impedance	-	1.1 16.4	-	KΩ pF
Output Impedance		1.1 5.0		KΩ pF
Temperature Coefficient of frequency	-	-72.0	-	ppm/K

D. FREQUENCY CHARACTERISTICS:

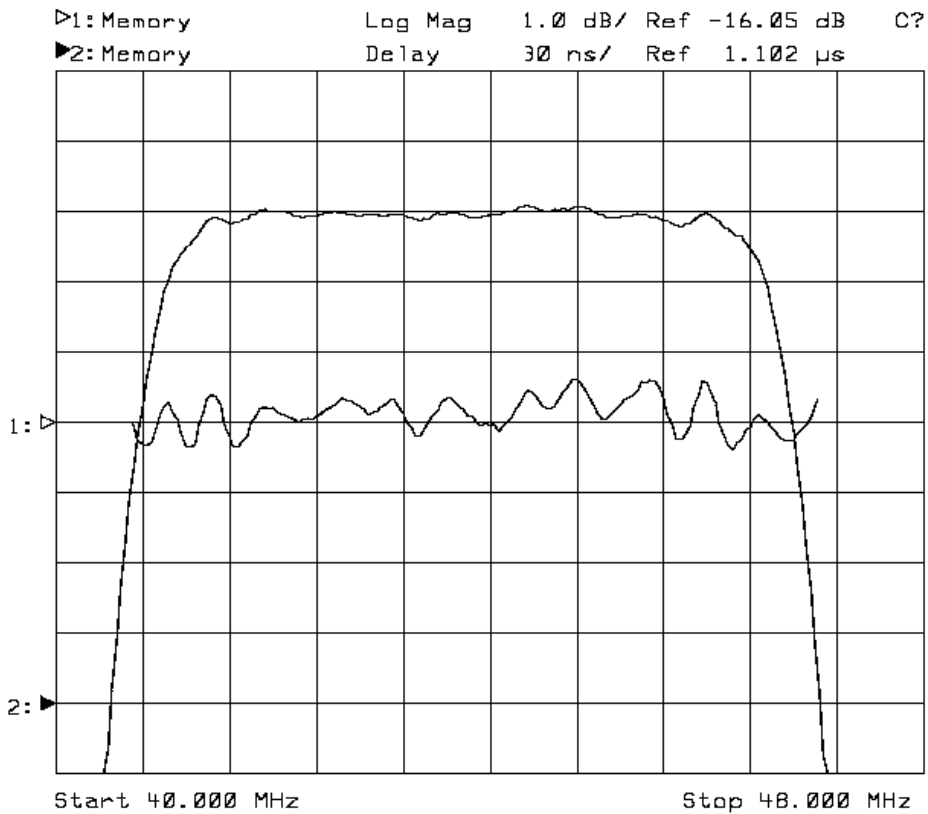
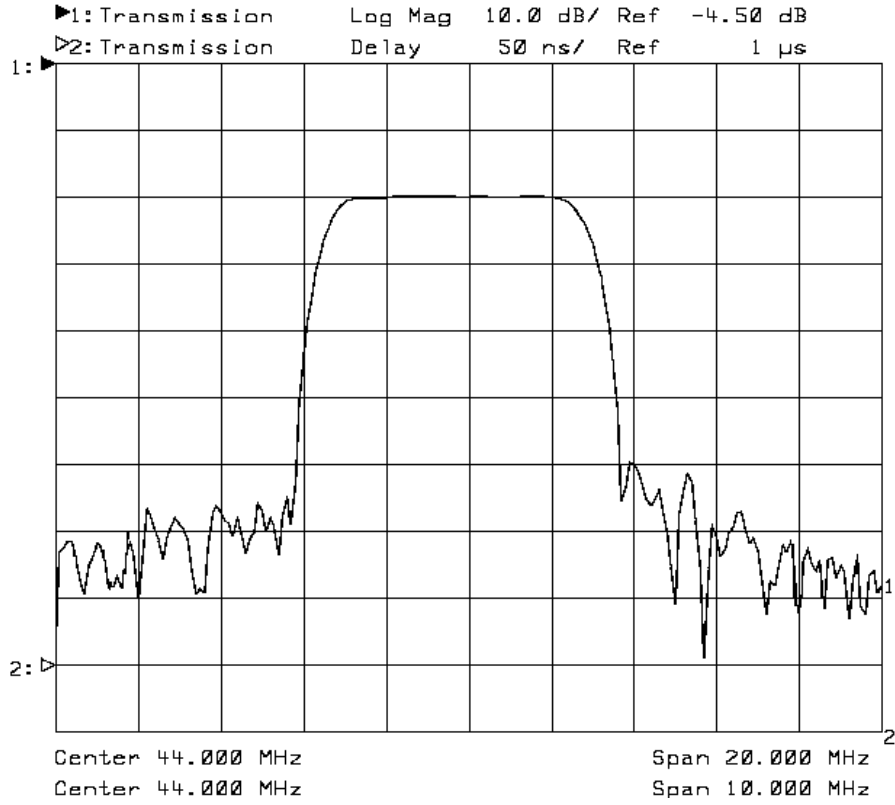

E. TEST CIRCUIT

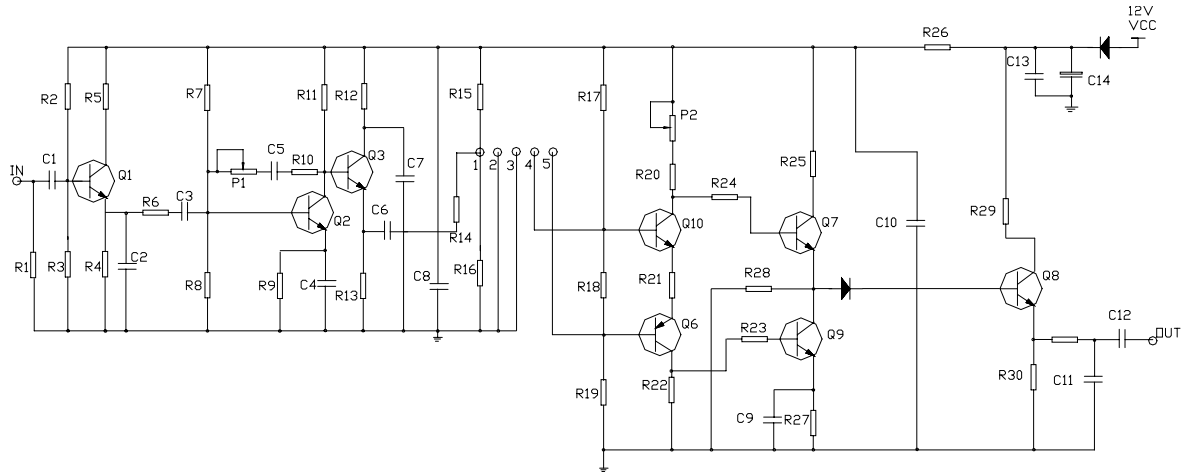

F. OUTLINE DRAWING:

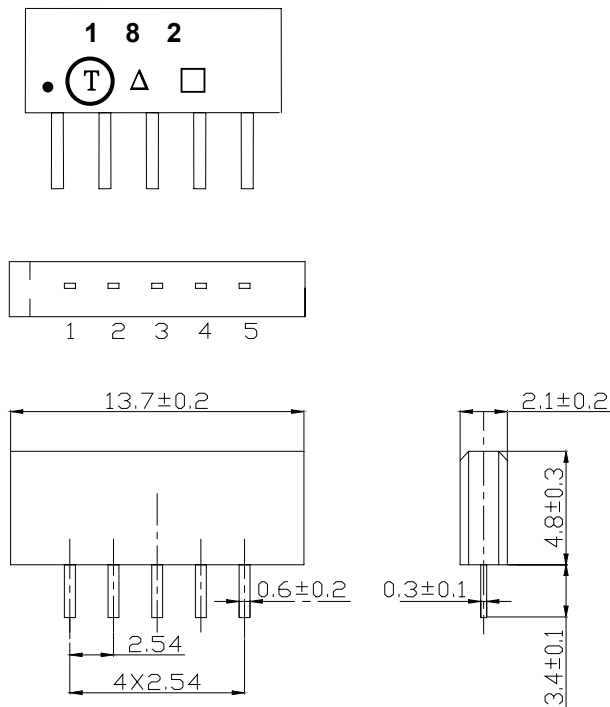

Pin 1: Input

Pin 2: Input-Ground

Pin 3: Chip carrier-Ground

Pin 4: Output

Pin 5: Output

YY : Date Code for Year

MM : Date Code for Month

Unit : mm

□ : Week Code (Follow the table from planner each year)

△ : Product / Year Code

Year	2005 2009	2006 2010	2007 2011	2008 2012
Product Code	B	b	<u>B</u>	<u>b</u>

G. PACKING:

Inside package:

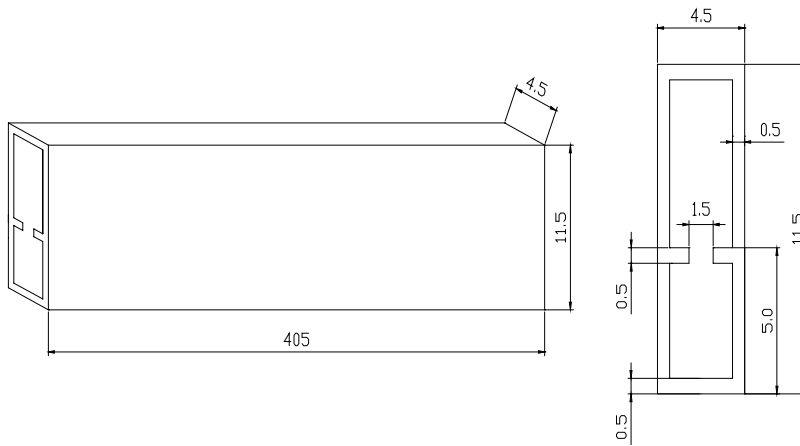

Dimensions of inside package:

Unit: mm

L	W	H	Products contained
405	4.50	11.50	28pcs

Dimensions of outside box:

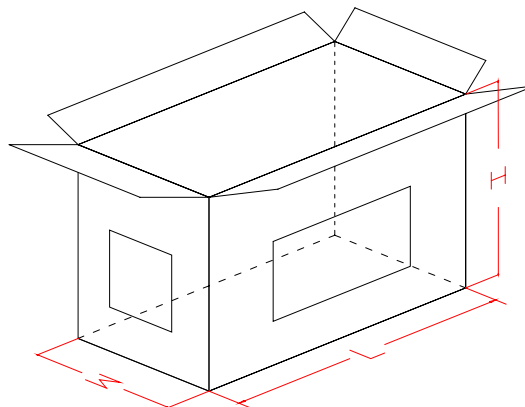

Unit: mm

L	W	H	Inside box contained
490	260	190	12000PCS

H. RECOMMENDED REFLOW PROFILE_:

