

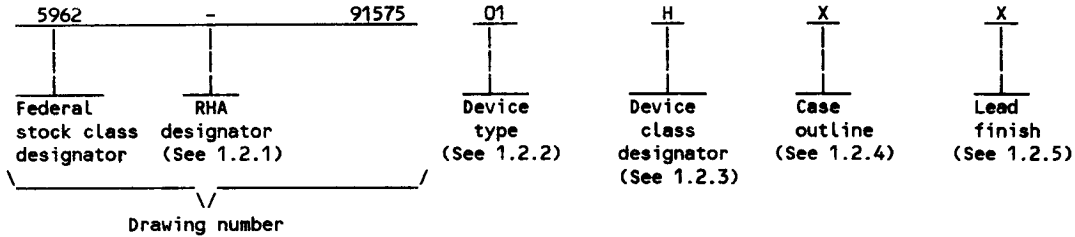

1. SCOPE

1.1 Scope. This drawing forms a part of a one part - one part number documentation system (see 6.6 herein). This drawing describes device requirements for hybrid microcircuits to be processed in accordance with MIL-H-38534. Two product assurance classes, military high reliability (device class H) and space application (device class K) and a choice of case outlines and lead finishes are available and are reflected in the Part or Identifying Number (PIN). When available, a choice of radiation hardness assurance levels are reflected in the PIN.

1.2 PIN. The PIN shall be as shown in the following example:



1.2.1 Radiation hardness assurance (RHA) designator. Device classes H and K RHA marked devices shall meet the MIL-H-38534 specified RHA levels and shall be marked with the appropriate RHA designator. A dash (-) indicates a non-RHA device.

1.2.2 Device type(s). The device type(s) shall identify the circuit function as follows:

<u>Device type</u>	<u>Generic number</u>	<u>Circuit function</u>
01	AHE2815D/CH	DC/DC converter, 15 W, ±15 V dual output
02	AHE2815D/CH - SLAVE	DC/DC converter, 15 W, ±15 V dual output
03	AHE2815D/CH - MASTER	DC/DC converter, 15 W, ±15 V dual output

1.2.3 Device class designator. This device class designator shall be a single letter identifying the product assurance level as follows:

<u>Device class</u>	<u>Device requirements documentation</u>
H or K	Certification and qualification to MIL-H-38534

1.2.4 Case outline(s). The case outline(s) shall be as designated in appendix C of MIL-M-38510, and as follows:

<u>Outline letter</u>	<u>Case outline</u>
X	See figure 1 (10-lead, 2.120" x 1.120" x .495"), dual-in-line package
Z	See figure 1 (10-lead, 2.880" x 1.120" x .495"), fanged package

1.2.5 Lead finish. The lead finish shall be as specified in MIL-H-38534 for classes H and K. Finish letter "X" shall not be marked on the microcircuit or its packaging. The "X" designation is for use in specifications when lead finishes A, B, and C are considered acceptable and interchangeable without preference.

<b>STANDARDIZED MILITARY DRAWING DEFENSE ELECTRONICS SUPPLY CENTER DAYTON, OHIO 45444</b>	<b>SIZE A</b>		<b>5962-91575</b>
		<b>REVISION LEVEL</b>	<b>SHEET 2</b>

DESC FORM 193A  
JUL 91



2.2 Order of precedence. In the event of a conflict between the text of this drawing and the references cited herein, the text of this drawing shall take precedence.

### 3. REQUIREMENTS

3.1 Item requirements. The individual item requirements shall be in accordance with MIL-H-38534 and as specified herein.

3.2 Design, construction, and physical dimensions. The design, construction, and physical dimensions shall be as specified in MIL-H-38534 and herein.

3.2.1 Case outline(s). The case outline(s) shall be in accordance with 1.2.4 herein and figure 1.

3.2.2 Terminal connections. The terminal connections shall be as specified on figure 2.

3.2.3 Block diagram. The block diagram shall be as specified on figure 3.

3.3 Electrical performance characteristics. Unless otherwise specified herein, the electrical performance characteristics are as specified in table I and shall apply over the full specified operating temperature range.

3.4 Electrical test requirements. The electrical test requirements shall be the subgroups specified in table II. The electrical tests for each subgroup are described in table I.

3.5 Marking. Marking shall be in accordance with MIL-H-38534. The part shall be marked with the PIN listed in 1.2 herein. In addition, the manufacturer's PIN may also be marked as listed in QML-38534.

3.6 Manufacturer eligibility. In addition to the general requirements of MIL-H-38534, the manufacturer of the part described herein shall submit for DESC-ECT review and approval electrical test data (variables format) on 22 devices from the initial quality conformance inspection group A lot sample, produced on the certified line, for each device type listed herein. The data should also include a summary of all parameters manually tested, and for those which, if any, are guaranteed.

3.7 Certificate of compliance. A certificate of compliance shall be required from a manufacturer in order to supply to this drawing. The certificate of compliance submitted to DESC-ECT shall affirm that the manufacturer's product meets the requirements of MIL-H-38534 and the requirements herein.

3.8 Certificate of conformance. A certificate of conformance as required in MIL-H-38534 shall be provided with each lot of microcircuits delivered to this drawing.

### 4. QUALITY ASSURANCE PROVISIONS

4.1 Sampling and inspection. Sampling and inspection procedures shall be in accordance with MIL-H-38534.

4.2 Screening. Screening shall be in accordance with MIL-H-38534. The following additional criteria shall apply:

a. Burn-in test, method 1015 of MIL-STD-883.

(1) Test condition A, B, C, or D using the circuit submitted with the certificate of compliance (see 3.7 herein).

(2)  $T_C$  as specified in accordance with table I of method 1015 of MIL-STD-883.

b. Interim and final electrical test parameters shall be as specified in table II herein, except interim electrical parameter tests prior to burn-in are optional at the discretion of the manufacturer.

STANDARDIZED MILITARY DRAWING DEFENSE ELECTRONICS SUPPLY CENTER DAYTON, OHIO 45444	SIZE A		5962-91575
		REVISION LEVEL	SHEET 4

DESC FORM 193A  
JUL 91

TABLE 1. Electrical performance characteristics.

Test	Symbol	Conditions -55°C ≤ T <sub>C</sub> ≤ +125°C V <sub>IN</sub> = 28 V dc ±5%, C <sub>L</sub> = 0 unless otherwise specified	Group A subgroups	Device types	Limits		Unit
					Min	Max	
Output voltage <u>1/</u>	V <sub>OUT</sub>	I <sub>OUT</sub> = 0	1	ALL	±14.85	±15.15	V
			2,3		±14.70	±15.30	
Output current <u>1/</u> <u>2/</u>	I <sub>OUT</sub>	V <sub>IN</sub> = 17, 28, and 40 V dc	1,2,3	ALL	0.0	±500	mA
Output ripple <u>3/</u> voltage <u>1/</u>	V <sub>RIP</sub>	V <sub>IN</sub> = 17, 28, and 40 V dc B.W. = dc to 2 MHz	1,2,3	ALL		60	mV p-p
Output power <u>4/</u> <u>1/</u> <u>2/</u>	P <sub>OUT</sub>	V <sub>IN</sub> = 17, 28, and 40 V dc	1,2,3	ALL	15		W
Line regulation <u>1/</u> <u>5/</u>	V <sub>RLINE</sub>	V <sub>IN</sub> = 17, 28, and 40 V dc I <sub>OUT</sub> = 0, ±250, and ±500 mA	1	ALL		35	mV
			2,3			75	
Load regulation <u>1/</u>	V <sub>RLOAD</sub>	V <sub>IN</sub> = 17, 28, and 40 V dc I <sub>OUT</sub> = 0, ±250, and ±500 mA	1,2,3	ALL		150	mV
Input current	I <sub>IN</sub>	I <sub>OUT</sub> = 0, inhibit (pin 2) tied to input return (pin 10)	1,2,3	ALL		18	mA
		I <sub>OUT</sub> = 0, inhibit (pin 2) = open				40	
Input ripple <u>3/</u> current	I <sub>RIP</sub>	I <sub>OUT</sub> = ±500 mA B.W. = dc to 2 MHz	1,2,3	ALL		50	mA p-p
Efficiency	E <sub>FF</sub>	I <sub>OUT</sub> = ±500 mA, T <sub>C</sub> = +25°C	1	ALL	80		%
Isolation	ISO	Input to output or any pin to case (except pin 8) at 500 V dc, T <sub>C</sub> = +25°C	1	ALL	100		MΩ
Capacitive <u>6/</u> <u>7/</u> load	C <sub>L</sub>	No effect on dc performance, T <sub>C</sub> = +25°C	4	ALL		200	μF
Power dissipation load fault	P <sub>D</sub>	Overload, T <sub>C</sub> = +25°C <u>8/</u>	1	ALL		6	W
		Short circuit, T <sub>C</sub> = +25°C				6	

See footnotes at end of table.

<b>STANDARDIZED MILITARY DRAWING DEFENSE ELECTRONICS SUPPLY CENTER DAYTON, OHIO 45444</b>	<b>SIZE A</b>		<b>5962-91575</b>
		<b>REVISION LEVEL</b>	<b>SHEET 5</b>

DESC FORM 193A  
JUL 91

TABLE 1. Electrical performance characteristics - Continued.

Test	Symbol	Conditions -55°C ≤ T <sub>C</sub> ≤ +125°C V <sub>IN</sub> = 28 V dc ±5%, C <sub>L</sub> = 0 unless otherwise specified	Group A subgroups	Device types	Limits		Unit
					Min	Max	
Switching frequency <u>1/</u>	F <sub>S</sub>	I <sub>OUT</sub> = ±500 mA	4,5,6	01	225	275	kHz
				02	225	245	
				03	250	275	
Output response to step transient load changes <u>9/</u>	V <sub>O-TLOAD</sub>	50 percent load to/from 100 percent load	4	ALL	-300	+300	mV pk
			5,6		-450	+450	
		No load to/from 50 percent load	4	ALL	-500	+500	
			5,6		-750	+750	
Recovery time step transient load changes <u>10/ 9/</u>	T <sub>T-LOAD</sub>	50 percent load to/from 100 percent load	4	ALL		70	μs
			5,6			100	
		No load to 50 percent load	4,5,6	ALL		1500	
			4,5,6		ALL		5
Output response to transient step <u>11/</u> line changes <u>7/</u>	V <sub>O-TLINE</sub>	Input step 17 to 40 V dc	4,5,6	ALL		1500	mV pk
		Input step 40 to 17 V dc	4,5,6	ALL		-1500	
Recovery time <u>10/</u> transient step <u>1/</u> line changes <u>12/</u>	T <sub>T-LINE</sub>	Input step 17 to 40 V dc	4,5,6	ALL		4	ms
		Input step 40 to 17 V dc	4,5,6	ALL		4	
Turn on overshoot <u>1/</u>	V <sub>Ton-OS</sub>	I <sub>OUT</sub> = 0 and ±500 mA	4,5,6	ALL		600	mV pk
Turn on delay <u>12/1/</u>	T <sub>on-D</sub>	I <sub>OUT</sub> = 0 and ±500 mA	4,5,6	ALL		10	ms
Load fault recovery <u>7/</u>	T <sub>r-LF</sub>		4,5,6	ALL		10	ms

See footnotes at end of table.

<b>STANDARDIZED MILITARY DRAWING DEFENSE ELECTRONICS SUPPLY CENTER DAYTON, OHIO 45444</b>	<b>SIZE A</b>		<b>5962-91575</b>
		<b>REVISION LEVEL</b>	<b>SHEET 6</b>

DESC FORM 193A  
JUL 91

TABLE 1. Electrical performance characteristics - Continued.

- 1/ Tested at each output.
- 2/ Parameter guaranteed by line and load regulation tests.
- 3/ Bandwidth guaranteed by design. Tested for 20 kHz to 2 MHz.
- 4/ Total power at both outputs. For operation at 16 V dc input, derate output power by 33 percent.
- 5/ When operating with unbalanced loads, at least 25 percent of the load must be on the positive output to maintain regulation.
- 6/ Capacitive load may be any value from 0 to the maximum limit without compromising dc performance. A capacitive load in excess of the maximum limit will not disturb loop stability but may interfere with the operation of the load fault detection circuitry, appearing as a short circuit during turn on.
- 7/ Parameter shall be tested as part of design characterization and after design or process changes. Thereafter parameters shall be guaranteed to the limits specified in table 1.
- 8/ An overload is that condition with a load in excess of the rated load but less than that necessary to trigger the short circuit protection and is the condition of maximum power dissipation.
- 9/ Load step transition time between 2 and 10 microseconds.
- 10/ Recovery time is measured from the initiation of the transient to where  $V_{OUT}$  has returned to within  $\pm 1$  percent of  $V_{OUT}$  at 50 percent load.
- 11/ Input step transition time between 2 and 10 microseconds.
- 12/ Turn on delay time measurement is for either a step application of power at the input or the removal of a ground signal from the inhibit pin (pin 2) while power is applied to the input.

<b>STANDARDIZED MILITARY DRAWING DEFENSE ELECTRONICS SUPPLY CENTER DAYTON, OHIO 45444</b>	<b>SIZE A</b>		<b>5962-91575</b>
		<b>REVISION LEVEL</b>	<b>SHEET 7</b>

DESC FORM 193A  
JUL 91

Case outline X

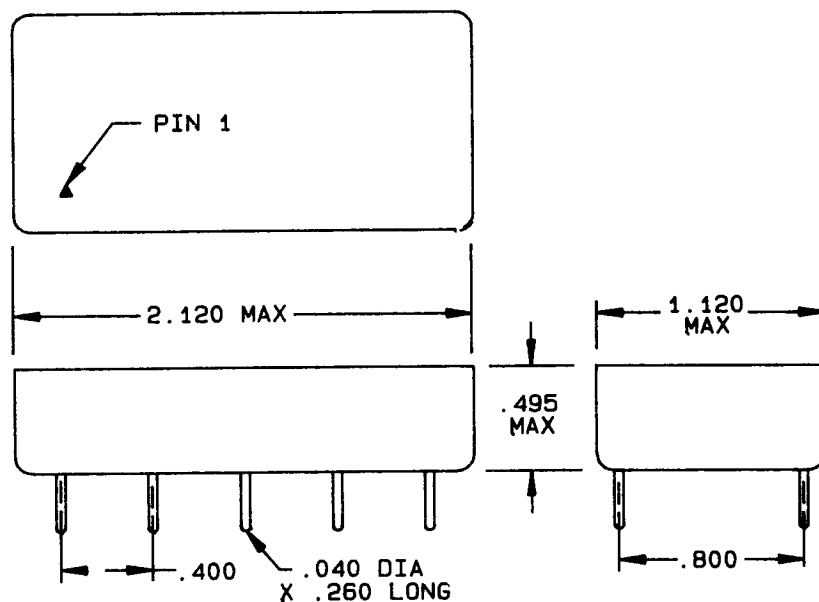
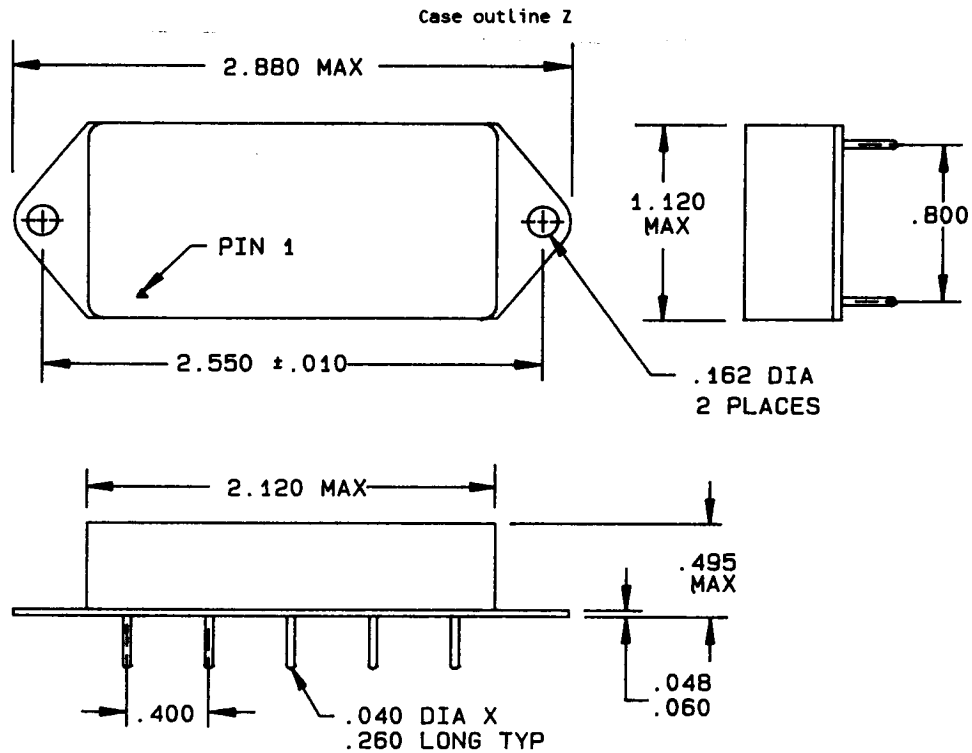

FIGURE 1. Case outlines.

<b>STANDARDIZED MILITARY DRAWING DEFENSE ELECTRONICS SUPPLY CENTER DAYTON, OHIO 45444</b>	<b>SIZE</b> <b>▲</b>		<b>5962-91575</b>
		<b>REVISION LEVEL</b>	<b>SHEET</b> <b>8</b>

DESC FORM 193A  
JUL 91





Inches	mm
.010	0.25
.040	1.02
.048	1.22
.060	1.52
.162	4.11
.260	6.60
.400	10.16
.495	12.57
.800	20.32
1.120	28.45
2.120	53.85
2.550	64.77
2.880	73.15

NOTES:

1. Dimensions are in inches.
2. Metric equivalents are for general information only.
3. Unless otherwise specified, tolerance is  $\pm 0.005$ .
4. Case outline X weight: 55 grams maximum.
5. Case outline Z weight: 58 grams maximum.

FIGURE 1. Case outlines - Continued.

<b>STANDARDIZED MILITARY DRAWING DEFENSE ELECTRONICS SUPPLY CENTER DAYTON, OHIO 45444</b>	<b>SIZE A</b>		<b>5962-91575</b>
		REVISION LEVEL	SHEET 9

DESC FORM 193A  
JUL 91

Device types	01	02 and 03
Case outlines	X and Z	X and Z
Terminal number	Terminal symbol	Terminal symbol
1	Input	Input
2	Inhibit in	Inhibit in
3	Positive output	Positive output
4	Output return	Output return
5	Negative output	Negative output
6	No connection	No connection
7	No connection	No connection
8	Case ground	Case ground
9	No connection	Sync in/out
10	Input return	Input return

FIGURE 2. Terminal connections.

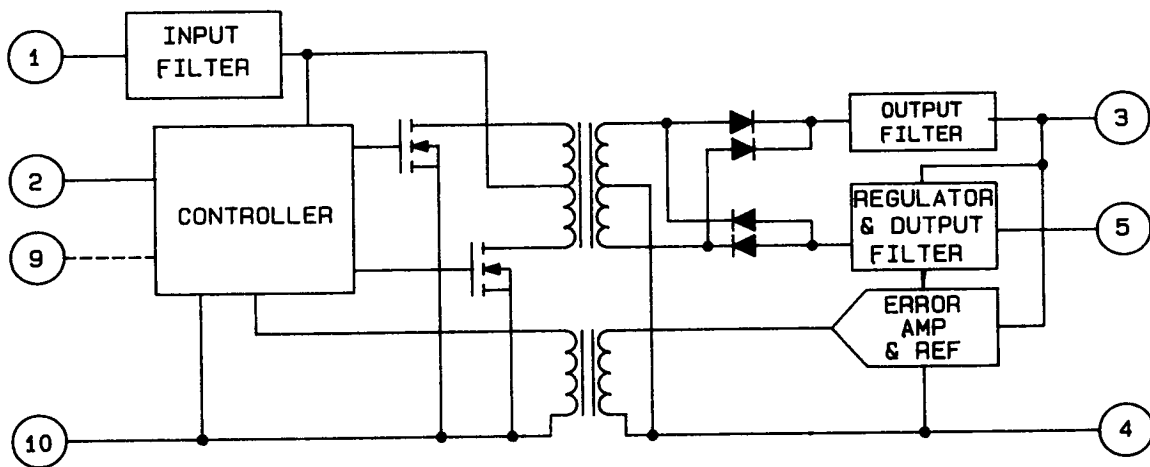

FIGURE 3. Block diagram.

<b>STANDARDIZED MILITARY DRAWING DEFENSE ELECTRONICS SUPPLY CENTER DAYTON, OHIO 45444</b>	<b>SIZE A</b>		<b>5962-91575</b>
		<b>REVISION LEVEL</b>	<b>SHEET 10</b>

DESC FORM 193A  
JUL 91

TABLE II. Electrical test requirements.

MIL-STD-883 test requirements	Subgroups (per method 5008, group A test table)
Interim electrical parameters	
Final electrical test parameters	1*,2,3,4,5,6
Group A test requirements	1,2,3,4,5,6
Group C end-point electrical parameters	1,4
Group E end-point electrical parameters for RHA devices	Subgroups ** (per method 5005, group A test table)

\* PDA applies to subgroup 1.

\*\* When applicable to this standardized military drawing,  
the subgroups shall be defined.

4.3 Quality conformance inspection. Quality conformance inspection shall be in accordance with MIL-H-38534 and as specified herein.

4.3.1 Group A inspection. Group A inspection shall be in accordance with MIL-H-38534 and as follows:

- a. Tests shall be as specified in table II herein.
- b. Subgroups 7, 8, 9, 10, and 11 shall be omitted.

4.3.2 Group B inspection. Group B inspection shall be in accordance with MIL-H-38534.

4.3.3 Group C inspection. Group C inspection shall be in accordance with MIL-H-38534 and as follows:

- a. End-point electrical parameters shall be as specified in table II herein.
- b. Steady-state life test conditions, method 1005 of MIL-STD-883.
  - (1) Test condition A, B, C, or D using the circuit submitted with the certificate of compliance (see 3.7 herein).
  - (2)  $T_C$  as specified in accordance with table I of method 1005 of MIL-STD-883.
  - (3) Test duration: 1,000 hours, except as permitted by method 1005 of MIL-STD-883.

4.3.4 Group D inspection. Group D inspection shall be in accordance with MIL-H-38534.

4.3.5 Group E inspection. Group E inspection is required only for parts intended to be marked as radiation hardness assured (see 3.5 herein). RHA levels for device classes H and K shall be M, D, R, and H. RHA quality conformance inspection sample tests shall be performed at the RHA level specified in the acquisition document.

- a. RHA tests for device classes H and K for levels M, D, R, and H shall be performed through each level to determine at what levels the devices meet the RHA requirements. These RHA tests shall be performed for initial qualification and after design or process changes which may affect the RHA performance of the device.
- b. End-point electrical parameters shall be as specified in table II herein.

STANDARDIZED MILITARY DRAWING DEFENSE ELECTRONICS SUPPLY CENTER DAYTON, OHIO 45444	SIZE A		5962-91575
		REVISION LEVEL	SHEET 11

- c. Prior to total dose irradiation, each selected sample shall be assembled in its qualified package. It shall pass the specified group A electrical parameters in table I for subgroups specified in table II herein.
- d. For device classes H and K, the devices shall be subjected to radiation hardness assured tests as specified in MIL-H-38534 for RHA level being tested, and meet the postirradiation end-point electrical parameter limits as defined in table I at  $T_A = +25^\circ\text{C} \pm 5$  percent, after exposure.
- e. Prior to and during total dose irradiation testing, the devices shall be biased to establish a worst case condition as specified in the radiation exposure circuit.
- f. For device classes H and K, subgroups 1 and 2 in table V, method 5005 of MIL-STD-883 shall be tested as appropriate for device construction.
- g. When specified in the purchase order or contract, a copy of the RHA delta limits shall be supplied.

5. PACKAGING

5.1 Packaging requirements. The requirements for packaging shall be in accordance with MIL-H-38534.

6. NOTES

6.1 Intended use. Microcircuits conforming to this drawing are intended for use for Government microcircuit applications (original equipment), design applications, and logistics purposes.

6.2 Replaceability. Microcircuits covered by this drawing will replace the same generic device covered by a contractor-prepared specification or drawing.

6.3 Configuration control of SMD's. All proposed changes to existing SMD's will be coordinated with the users of record for the individual documents. This coordination will be accomplished in accordance with MIL-STD-481 using DD Form 1693, Engineering Change Proposal (Short Form).

6.4 Record of users. Military and industrial users shall inform Defense Electronics Supply Center when a system application requires configuration control and the applicable SMD. DESC will maintain a record of users and this list will be used for coordination and distribution of changes to the drawings. Users of drawings covering microelectronic devices (FSC 5962) should contact DESC-ECT, telephone (513) 296-6047.

6.5 Comments. Comments on this drawing should be directed to DESC-ECT, Dayton, Ohio 45444, or telephone (513) 296-5374.

<b>STANDARDIZED MILITARY DRAWING DEFENSE ELECTRONICS SUPPLY CENTER DAYTON, OHIO 45444</b>	<b>SIZE A</b>		<b>5962-91575</b>
		<b>REVISION LEVEL</b>	<b>SHEET 12</b>

DESC FORM 193A  
JUL 91

6.6 One part - one part number system. The one part - one part number system described below has been developed to allow for transitions between identical generic devices covered by the four major microcircuit requirements documents (MIL-M-38510, MIL-H-38534, MIL-I-38535, and 1.2.1 of MIL-STD-883) without the necessity for the generation of unique PIN's. The four military requirements documents represent different class levels, and previously when a device manufacturer upgraded military product from one class level to another, the benefits of the upgraded product were unavailable to the Original Equipment Manufacturer (OEM), that was contractually locked into the original unique PIN. By establishing a one part number system covering all four documents, the OEM can acquire to the highest class level available for a given generic device to meet system needs without modifying the original contract parts selection criteria.

<u>Military documentation format</u>	<u>Example PIN under new system</u>	<u>Manufacturing source Listing</u>	<u>Document Listing</u>
New MIL-M-38510 Military Detail Specifications (in the SMD format)	5962-XXXXZZ(B or S)YY	QPL-38510 (Part 1 or 2)	MIL-BUL-103
New MIL-H-38534 Standardized Military Drawings	5962-XXXXZZ(H or K)YY	QML-38534	MIL-BUL-103
New MIL-I-38535 Standardized Military Drawings	5962-XXXXZZ(Q or V)YY	QML-38535	MIL-BUL-103
New 1.2.1 of MIL-STD-883 Standardized Military Drawings	5962-XXXXZZ(M)YY	MIL-BUL-103	MIL-BUL-103

6.7 Sources of supply for device classes H and K. Sources of supply for device classes H and K are listed in QML-38534. The vendors listed in QML-38534 have submitted a certificate of compliance (see 3.7 herein) to DESC-ECT and have agreed to this drawing.

<b>STANDARDIZED MILITARY DRAWING DEFENSE ELECTRONICS SUPPLY CENTER DAYTON, OHIO 45444</b>	<b>SIZE A</b>		<b>5962-91575</b>
		<b>REVISION LEVEL</b>	<b>SHEET 13</b>

DESC FORM 193A  
JUL 91