

Fast CMOS 1-of-8 Decoder
Product Features

- PI74FCT138/238T is pin compatible with bipolar FAST™ Series at a higher speed and lower power consumption
- TTL input and output levels
- Extremely low static power
- Hysteresis on all inputs
- Industrial operating temperature range: -40°C to $+85^{\circ}\text{C}$
- Packages available:
 - 16-pin 150 mil wide plastic QSOP (Q)
 - 16-pin 300 mil wide plastic SOIC (S)
 - 16-pin 150 mil wide plastic SOIC (W)

Product Description

Pericom Semiconductor's PI74FCT series of logic circuits are produced using the Company's advanced 0.8 micron CMOS technology, achieving industry leading speed grades.

These high-speed decoders accept three binary weighted inputs (A_0 , A_1 , A_2) and gives eight mutually exclusive active LOW outputs (\bar{O}_0 - \bar{O}_7 : PI74FCT138T) or active HIGH outputs (O_0 - O_7 : PI74FCT238T) when enabled. These devices contain three enable inputs, two active LOW (\bar{E}_1 , \bar{E}_2) and one active HIGH (E_3). On the PI74FCT138T all outputs will be HIGH and on the PI74FCT238T all outputs will be LOW, except when \bar{E}_1 and \bar{E}_2 are LOW and E_3 is HIGH.

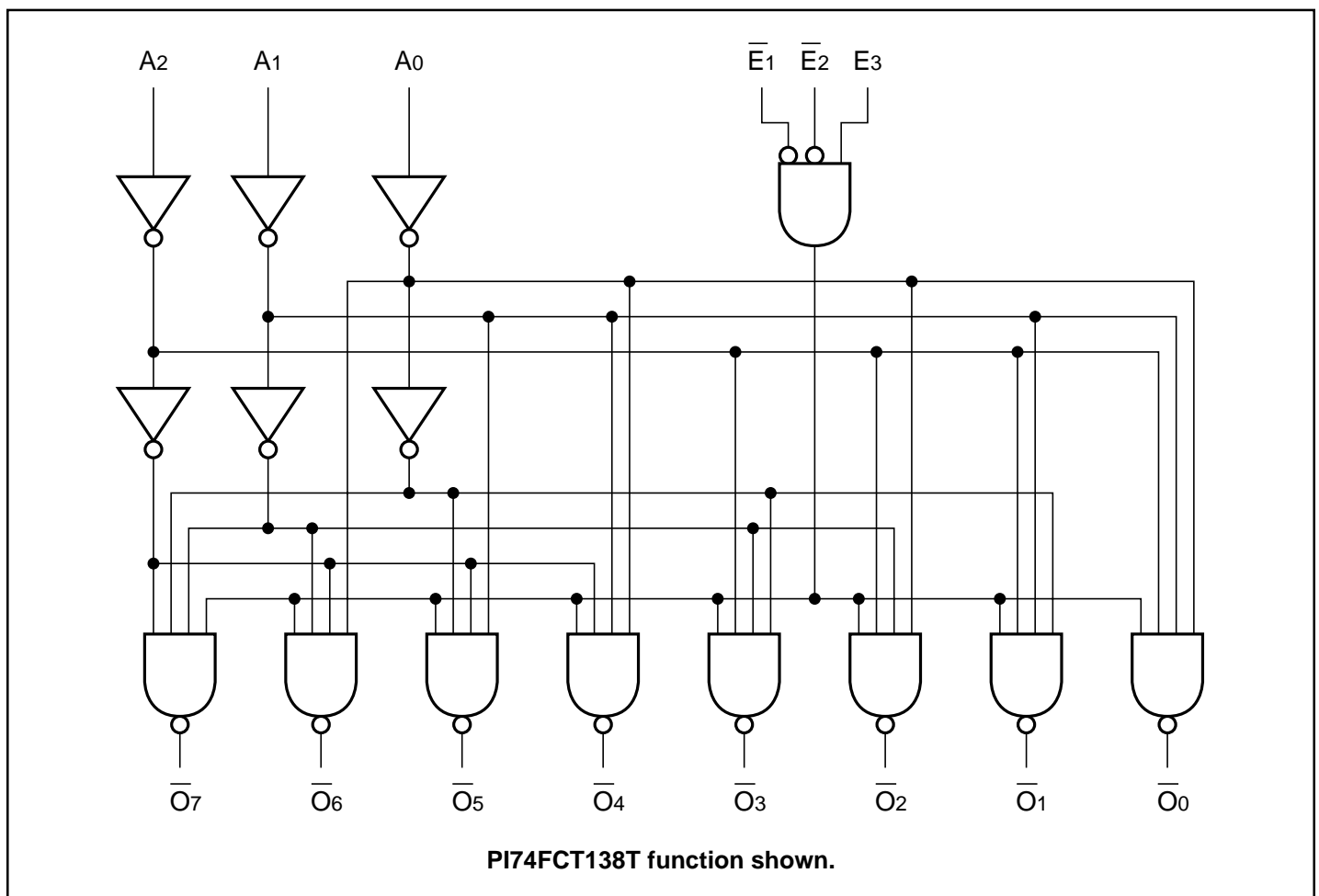
Logic Block Diagram

PI74FCT138T Product Pin Configuration

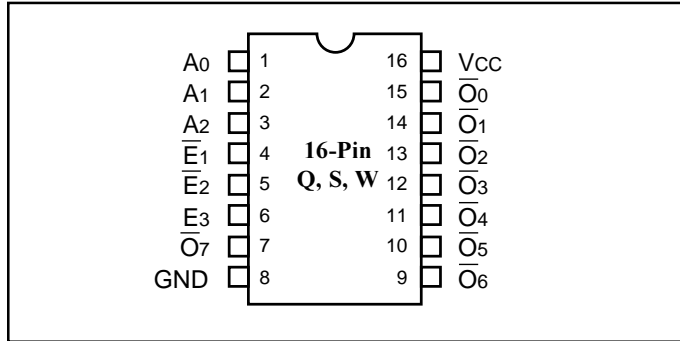

PI74FCT138T Product Pin Description

Pin Name	Description
A0-A2	Address Inputs
$\bar{E}1, \bar{E}2$	Enable Inputs (Active LOW)
E3	Enable Input (Active HIGH)
$\bar{O}0-\bar{O}7$	Outputs (Active LOW)

PI74FCT138T Truth Table (1)

Inputs						Outputs								
$\bar{E}1$	$\bar{E}2$	E3	A0	A1	A2	$\bar{O}0$	$\bar{O}1$	$\bar{O}2$	$\bar{O}3$	$\bar{O}4$	$\bar{O}5$	$\bar{O}6$	$\bar{O}7$	Function
H	X	X	X	X	X	H	H	H	H	H	H	H	H	Disable
X	H	X	X	X	X	H	H	H	H	H	H	H	H	Disable
X	X	L	X	X	X	H	H	H	H	H	H	H	H	Disable
L	L	H	L	L	L	L	H	H	H	H	H	H	H	A2-0 = 0
L	L	H	H	L	L	H	L	H	H	H	H	H	H	A2-0 = 1
L	L	H	L	H	L	H	H	L	H	H	H	H	H	A2-0 = 2
L	L	H	H	H	L	H	H	H	L	H	H	H	H	A2-0 = 3
L	L	H	L	L	H	H	H	H	H	L	H	H	H	A2-0 = 4
L	L	H	H	L	H	H	H	H	H	H	L	H	H	A2-0 = 5
L	L	H	L	H	H	H	H	H	H	H	H	L	H	A2-0 = 6
L	L	H	H	H	H	H	H	H	H	H	H	H	L	A2-0 = 7

Note:

- H = HIGH Voltage Level
L = LOW Voltage Level
X = Don't Care

PI74FCT238T Product Pin Configuration

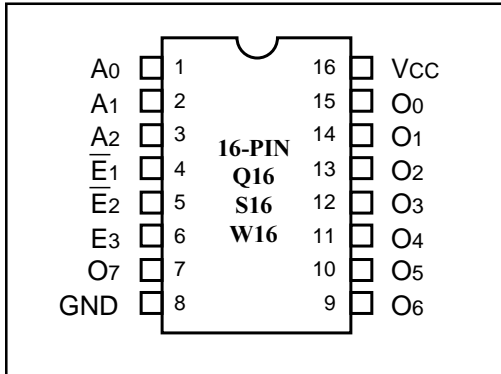

PI74FCT238T Product Pin Description

Pin Name	Description
A0-A2	Address Inputs
$\bar{E}1, \bar{E}2$	Enable Inputs (Active LOW)
E3	Enable Input (Active HIGH)
O0-O7	Outputs (Active HIGH)

PI74FCT238T Truth Table ⁽¹⁾

Inputs						Outputs								Function
$\bar{E}1$	$\bar{E}2$	E3	A0	A1	A2	O0	O1	O2	O3	O4	O5	O6	O7	
H	X	X	X	X	X	L	L	L	L	L	L	L	L	Disable
X	H	X	X	X	X	L	L	L	L	L	L	L	L	Disable
X	X	L	X	X	X	L	L	L	L	L	L	L	L	Disable
L	L	H	L	L	L	H	L	L	L	L	L	L	L	A2-0 = 0
L	L	H	H	L	L	L	H	L	L	L	L	L	L	A2-0 = 1
L	L	H	L	H	L	L	L	H	L	L	L	L	L	A2-0 = 2
L	L	H	H	H	L	L	L	L	H	L	L	L	L	A2-0 = 3
L	L	H	L	L	H	L	L	L	L	H	L	L	L	A2-0 = 4
L	L	H	H	L	H	L	L	L	L	L	H	L	L	A2-0 = 5
L	L	H	L	H	H	L	L	L	L	L	L	H	L	A2-0 = 6
L	L	H	H	H	H	L	L	L	L	L	L	L	H	A2-0 = 7

Note:

- H = HIGH Voltage Level
L = LOW Voltage Level
X = Don't Care

Maximum Ratings

(Above which the useful life may be impaired. For user guidelines, not tested.)

Storage Temperature	-65°C to +150°C
Ambient Temperature with Power Applied	-40°C to +85°C
Supply Voltage to Ground Potential (Inputs & Vcc Only)	-0.5V to +7.0V
Supply Voltage to Ground Potential (Outputs & D/O Only)	-0.5V to +7.0V
DC Input Voltage	-0.5V to +7.0V
DC Output Current	120 mA
Power Dissipation	0.5W

Note:

Stresses greater than those listed under MAXIMUM RATINGS may cause permanent damage to the device. This is a stress rating only and functional operation of the device at these or any other conditions above those indicated in the operational sections of this specification is not implied. Exposure to absolute maximum rating conditions for extended periods may affect reliability.

DC Electrical Characteristics (Over the Operating Range, $T_A = -40^\circ\text{C}$ to $+85^\circ\text{C}$, $V_{CC} = 5.0\text{V} \pm 5\%$)

Parameters	Description	Test Conditions ⁽¹⁾		Min.	Typ ⁽²⁾	Max.	Units
V _{OH}	Output HIGH Voltage	V _{CC} = Min., V _{IN} = V _{IH} or V _{IL}	I _{OH} = -15.0 mA	2.4	3.0		V
V _{OL}	Output LOW Current	V _{CC} = Min., V _{IN} = V _{IH} or V _{IL}	I _{OL} = 48 mA		0.3	0.50	V
V _{IH}	Input HIGH Voltage	Guaranteed Logic HIGH Level		2.0			V
V _{IL}	Input LOW Voltage	Guaranteed Logic LOW Level				0.8	V
I _{IH}	Input HIGH Current	V _{CC} = Max.	V _{IN} = V _{CC}			1	μA
I _{IL}	Input LOW Current	V _{CC} = Max.	V _{IN} = GND			-1	μA
V _{IK}	Clamp Diode Voltage	V _{CC} = Min., I _{IN} = -18 mA			-0.7	-1.2	V
I _{OS}	Short Circuit Current	V _{CC} = Max. ⁽³⁾ , V _{OUT} = GND		-60	-120	-225	mA
I _{OFF}	Power Down Disable	V _{CC} = GND, V _{OUT} = 4.5V		—	—	100	μA
V _H	Input Hysteresis				200		mV

Capacitance ($T_A = 25^\circ\text{C}$, $f = 1\text{ MHz}$)

Parameters ⁽⁴⁾	Description	Test Conditions	Typ	Max.	Units
C _{IN}	Input Capacitance	V _{IN} =0V	6	10	pF
C _{OUT}	Output Capacitance	V _{OUT} =0V	8	12	pF

Notes:

1. For Max. or Min. conditions, use appropriate value specified under Electrical Characteristics for the applicable device type.
2. Typical values are at V_{CC} = 5.0V, +25°C ambient and maximum loading.
3. Not more than one output should be shorted at one time. Duration of the test should not exceed one second.
4. This parameter is determined by device characterization but is not production tested.

Power Supply Characteristics

Parameters	Description	Test Conditions ⁽¹⁾		Min.	Typ ⁽²⁾	Max.	Units
I _{CC}	Quiescent Power Supply Current	V _{CC} = Max.	V _{IN} = GND or V _{CC}		0.1	500	μA
ΔI _{CC}	Supply Current per Input @ TTL HIGH	V _{CC} = Max.	V _{IN} = 3.4V ⁽³⁾		0.5	2.0	mA
I _{CCD}	Supply Current per Input per MHz ⁽⁴⁾	V _{CC} = Max., Outputs Open One Input Toggling 50% Duty Cycle	V _{IN} = V _{CC} V _{IN} = GND		0.15	0.3	mA/ MHz
I _C	Total Power Supply Current ⁽⁶⁾	V _{CC} = Max., Outputs Open f _{CP} = 10 MHz, 50% Duty Cycle Toggle $\bar{E}1$, $\bar{E}2$, or E3 One Bit toggling	V _{IN} = V _{CC} V _{IN} = GND		1.5	4.0 ⁽⁵⁾	mA
			V _{IN} = 3.4V V _{IN} = GND		1.8	5.0 ⁽⁵⁾	

Notes:

- For Max. or Min. conditions, use appropriate value specified under Electrical Characteristics for the applicable device.
- Typical values are at V_{CC} = 5.0V, +25°C ambient.
- Per TTL driven input (V_{IN} = 3.4V); all other inputs at V_{CC} or GND.
- This parameter is not directly testable, but is derived for use in Total Power Supply Calculations.
- Values for these conditions are examples of the I_{CC} formula. These limits are guaranteed but not tested.
- I_C = I_{QUIESCENT} + I_{INPUTS} + I_{DYNAMIC}
 $I_C = I_{CC} + \Delta I_{CC} D_H N_T + I_{CCD} (f_{CP}/2 + f_i N_i)$
 I_{CC} = Quiescent Current
 ΔI_{CC} = Power Supply Current for a TTL High Input (V_{IN} = 3.4V)
 D_H = Duty Cycle for TTL Inputs High
 N_T = Number of TTL Inputs at D_H
 I_{CCD} = Dynamic Current Caused by an Input Transition Pair (HLH or LHL)
 f_{CP} = Clock Frequency for Register Devices (Zero for Non-Register Devices)
 f_o = Output Frequency
 N_o = Number of Outputs at f_o
 All currents are in milliamps and all frequencies are in megahertz.

PI74FCT138T Switching Characteristics over Operating Range

Parameters	Description	Conditions ⁽¹⁾	138T		138AT		138CT	
			Com.		Com.		Com.	
			Min	Max	Min	Max	Min	Max
t _{PLH} t _{PHL}	Propagation Delay A _n to \bar{O}_n	C _L = 50 pF R _L = 500Ω	15	90	15	58	15	51
t _{PLH} t _{PHL}	Propagation Delay \bar{E}_1 or \bar{E}_2 to \bar{O}_n		15	90	15	59	15	52
t _{PLH} t _{PHL}	Propagation Delay E ₃ to \bar{O}_n		15	90	15	59	15	52

Notes:

1. See test circuit and wave forms.
2. Minimum limits are guaranteed but not tested on Propagation Delays.

PI74FCT238T Switching Characteristics over Operating Range

Parameters	Description	Conditions ⁽¹⁾	238T		238AT		238CT		Unit
			Com.		Com.		Com.		
			Min	Max	Min	Max	Min	Max	
t _{PLH} t _{PHL}	Propagation Delay A _n to \bar{O}_n	C _L = 50 pF R _L = 500Ω	1.5	9.0	1.5	5.8	1.5	5.0	ns
t _{PLH} t _{PHL}	Propagation Delay \bar{E}_1 or \bar{E}_2 to \bar{O}_n		1.5	8.0	1.5	5.9	1.5	5.0	ns
t _{PLH} t _{PHL}	Propagation Delay E ₃ to \bar{O}_n		1.5	8.0	1.5	5.9	1.5	5.0	ns

Notes:

1. See test circuit and wave forms.
2. Minimum limits are guaranteed but not tested on Propagation Delays.