



TFT LCD Approval Specification

MODEL NO.: N12111 - L02

Revision : C1

Customer : _____

Approved by : _____

Note :

Liquid Crystal Display Division	
QRA Division.	OA Head Division.
Approval	Approval
	<p><i>Wu Chao-Wen</i></p> <p><i>11/11 '04</i></p> <p><i>16235</i></p>

- CONTENTS -

REVISION HISTORY	-----	3
1. GENERAL DESCRIPTION	-----	4
1.1 OVERVIEW		
1.2 FEATURES		
1.3 APPLICATION		
1.4 GENERAL SPECIFICATIONS		
1.5 MECHANICAL SPECIFICATIONS		
2. ABSOLUTE MAXIMUM RATINGS	-----	5
2.1 ABSOLUTE RATINGS OF ENVIRONMENT		
2.2 ELECTRICAL ABSOLUTE RATINGS		
2.2.1 TFT LCD MODULE		
2.2.2 BACKLIGHT UNIT		
3. ELECTRICAL CHARACTERISTICS	-----	7
3.1 TFT LCD MODULE		
3.2 BACKLIGHT UNIT		
4. BLOCK DIAGRAM	-----	10
4.1 TFT LCD MODULE		
4.2 BACKLIGHT UNIT		
5. INPUT TERMINAL PIN ASSIGNMENT	-----	11
5.1 TFT LCD MODULE		
5.2 BACKLIGHT UNIT		
5.3 TIMING DIAGRAM OF LVDS INPUT SIGNAL		
5.4 COLOR DATA INPUT ASSIGNMENT		
5.5 EDID DATA STRUCTURE		
5.6 EDID SIGNAL SPECIFICATION		
6. INTERFACE TIMING	-----	18
6.1 INPUT SIGNAL TIMING SPECIFICATIONS		
6.2 POWER ON/OFF SEQUENCE		
7. OPTICAL CHARACTERISTICS	-----	20
7.1 TEST CONDITIONS		
7.2 OPTICAL SPECIFICATIONS		
8. PRECAUTIONS	-----	24
8.1 HANDLING PRECAUTIONS		
8.2 STORAGE PRECAUTIONS		
8.3 OPERATION PRECAUTIONS		
9. PACKING	-----	25
9.1 CARTON		
9.2 PALLET		
10. DEFINITION OF LABELS	-----	27
10.1 CMO MODULE LABEL		
10.2 CARTON LABEL		
11. Outline Dimension Drawing	-----	29

REVISION HISTORY

Version	Date	Page (New)	Section	Description
Ver 2.0	Nov. 10,'04	All	All	Approval specification first issued.

1. GENERAL DESCRIPTION

1.1 OVERVIEW

N12111 -L02 is a 12.1" TFT Liquid Crystal Display module with single CCFL Backlight unit and 20 pins LVDS interface. This module supports 1280 x 800 Wide-XGA mode and can display 262,144 colors. The optimum viewing angle is at 6 o'clock direction. The inverter module for Backlight is not built in.

1.2 FEATURES

- Thin and light weight
- WXGA (1280 x 800 pixels) resolution
- 3.3V LVDS (Low Voltage Differential Signaling) interface with 1 pixel/clock

1.3 APPLICATION

- TFT LCD Notebook

1.4 GENERAL SPECIFICATIONS

Item	Specification	Unit	Note
Active Area	261.12 (H) x 163.2 (V) (12.1" diagonal)	mm	(1)
Bezel Opening Area	264.12 (H) x 166.2 (V)	mm	
Driver Element	a-si TFT active matrix	-	-
Pixel Number	1280 x R.G.B. x 800	pixel	-
Pixel Pitch	0.204 (H) x 0.204 (V)	mm	-
Pixel Arrangement	RGB vertical stripe	-	-
Display Colors	262,144	color	-
Transmissive Mode	Normally white	-	-
Surface Treatment	Hard coating (2H), glare type	-	-

1.5 MECHANICAL SPECIFICATIONS

Item		Min.	Typ.	Max.	Unit	Note
Module Size	Horizontal(H)	275.3	275.8	276.3	mm	(1)
	Vertical(V)	177.5	178	178.5	mm	
	Depth(D)	-	5.2	5.5	mm	
Weight		-	300	315	g	-

Note (1) Please refer to the attached drawings for more information of front and back outline dimensions.

2. ABSOLUTE MAXIMUM RATINGS

2.1 ABSOLUTE RATINGS OF ENVIRONMENT

Item	Symbol	Value		Unit	Note
		Min.	Max.		
Storage Temperature	T _{ST}	-20	+60	°C	(1)
Operating Ambient Temperature	T _{OP}	0	+50	°C	(1), (2)
Shock (Non-Operating)	S _{NOP}	-	200	G	(3), (5)
Vibration (Non-Operating)	V _{NOP}	-	1.5	G	(4), (5)

Note (1) Temperature and relative humidity range is shown in the figure below.

- (a) 90 %RH Max. ($T_a \leq 40\text{ }^\circ\text{C}$).
- (b) Wet-bulb temperature should be 39 °C Max. ($T_a > 40\text{ }^\circ\text{C}$).
- (c) No condensation.

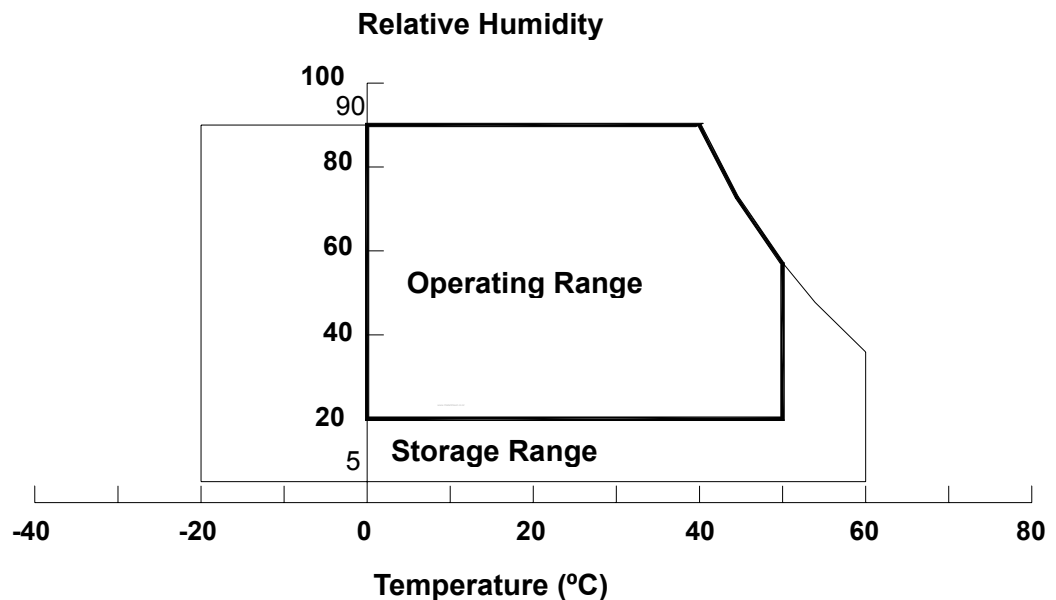

Note (2) The temperature of panel surface should be 0 °C Min. and 50 °C Max.

Note (3) 3ms, half sine wave, 1 time for ± X, ± Y, ± Z.

Note (4) 10 ~ 500Hz, 0.5 Hr/cycle, 0.5hr each X, Y, Z,

Note (5) At testing Vibration and Shock, the fixture in holding the module has to be hard and rigid enough so that the module would not be twisted or bent by the fixture.

2.2 ELECTRICAL ABSOLUTE RATINGS

2.2.1 TFT LCD MODULE

Item	Symbol	Value		Unit	Note
		Min.	Max.		
Power Supply Voltage	V _{CC}	-0.3	+4.0	V	(1)
Logic Input Voltage	V _{IN}	-0.3	V _{CC} +0.3	V	

2.2.2 BACKLIGHT UNIT

Item	Symbol	Value		Unit	Note
		Min.	Max.		
Lamp Voltage	V _L	-	2.5K	V _{RMS}	(1), (2), I _L = 6.0 mA
Lamp Current	I _L	-	6.5	mA _{RMS}	(1), (2)
Lamp Frequency	F _L	-	80	KHz	

Note (1) Permanent damage to the device may occur if maximum values are exceeded. Function operation should be restricted to the conditions described under Normal Operating Conditions.

Note (2) Specified values are for lamp (Refer to Section 3.2 for further information).

3. ELECTRICAL CHARACTERISTICS

3.1 TFT LCD MODULE

Ta = 25 ± 2 °C

Parameter	Symbol	Value			Unit	Note
		Min.	Typ.	Max.		
Power Supply Voltage	V _{CC}	3.0	3.3	3.6	V	-
Ripple Voltage	V _{RP}	-	-	100	mV	-
Rush Current	I _{RUSH}	-	-	1.5	A	(2)
Power Supply Current	White	-	340		mA	(3)a
	Black	-	410		mA	(3)b
	Vertical Stripe	-	440		mA	(3)c
Differential Input Voltage for LVDS Receiver Threshold	"H" Level	V _{IH}	-	+100	mV	-
	"L" Level	V _{IL}	-100	-	mV	-
Terminating Resistor	R _T	-	100	-	Ohm	-

Note (1) The module should be always operated within above ranges.

Note (2) Measurement Conditions:

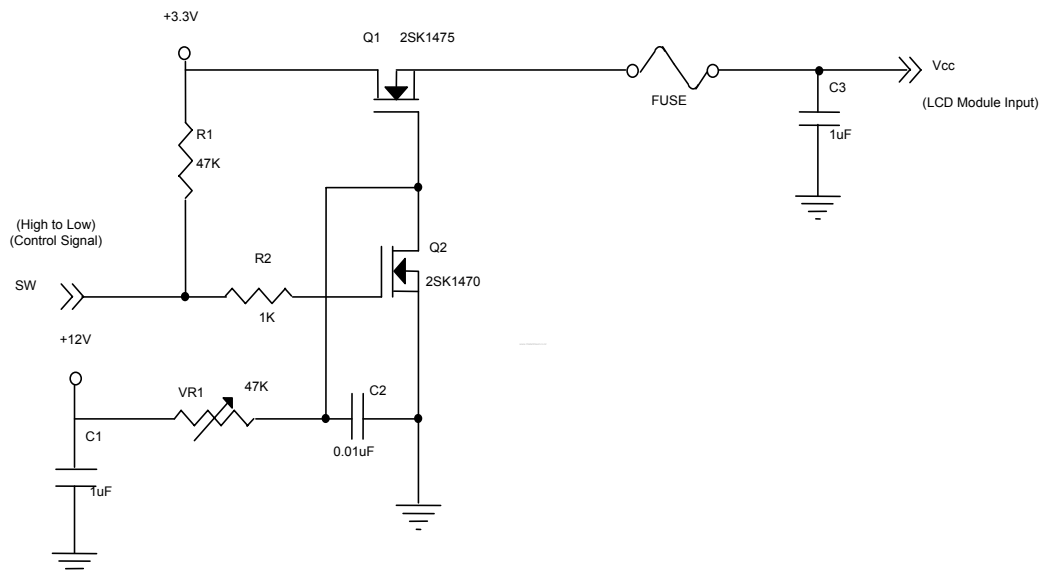

Vcc rising time is 470us

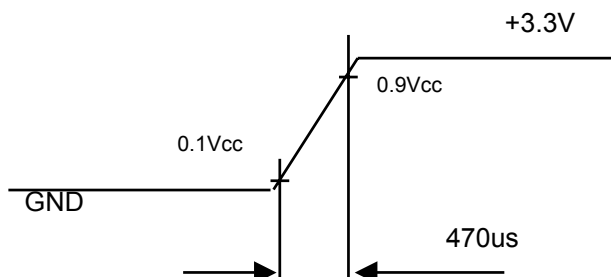

Note (3) The specified power supply current is under the conditions at V_{CC} = 3.3 V, Ta = 25 ± 2 °C, DC Current and f_v = 60 Hz, whereas a power dissipation check pattern below is displayed.

a. White Pattern



Active Area

b. Black Pattern

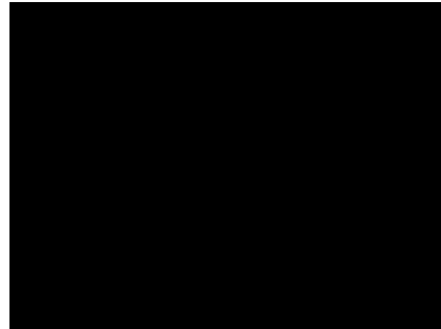

Active Area

c. Vertical Stripe Pattern

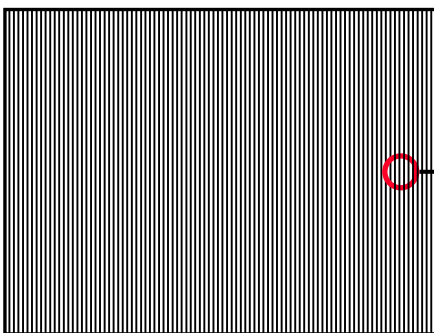

Active Area

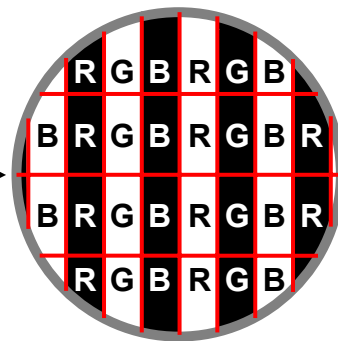

3.2 BACKLIGHT UNIT

Ta = 25 ± 2 °C

Parameter	Symbol	Value			Unit	Note
		Min.	Typ.	Max.		
Lamp Input Voltage	V _L	548	610	673	V _{RMS}	I _L = 6.0 mA
Lamp Current	I _L	2.0	6.0	6.5	mA _{RMS}	(1),(2)
		3.0				(1),(3)
Lamp Turn On Voltage	V _S	-	-	1,300 (25 deg C)	V _{RMS}	(4)
		-	-	1,550 (0 deg C)	V _{RMS}	(4)
Operating Frequency	F _L	40	-	80	KHz	(5)
Lamp Life Time	L _{BL}	10,000	-	-	Hrs	(7)
Power Consumption	P _L	-	3.66	-	W	(4), I _L = 6.0 mA

Note (1) Lamp current is measured by utilizing a high frequency current meter as shown below:

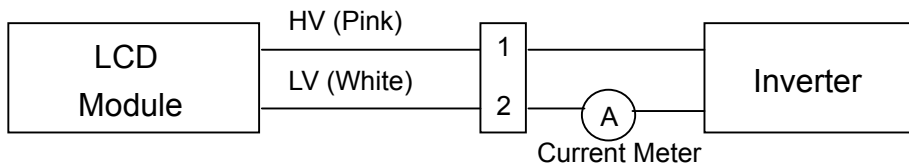

Note (2) for burst mode inverter design

Note (3) for continuous mode inverter design

Note (4) The voltage shown above should be applied to the lamp for more than 1 second after startup.

Otherwise the lamp may not be turned on.

Note (5) The lamp frequency may generate interference with horizontal synchronous frequency from the display, and this may cause line flow on the display. In order to avoid interference, the lamp frequency should be detached from the horizontal synchronous frequency and its harmonics as far as possible.

Note (6) $P_L = I_L \times V_L$

Note (7) The lifetime of lamp is defined as the time when it continues to operate under the conditions at $T_a = 25 \pm 2 \text{ }^\circ\text{C}$ and $I_L = 6.0 \text{ mA}_{\text{RMS}}$ until one of the following events occurs:

- (a) When the brightness becomes $\leq 50\%$ of its original value.
- (b) When the effective ignition length becomes $\leq 80\%$ of its original value. (Effective ignition length is defined as an area that the brightness is less than 70% compared to the center point.)

Note (8) The waveform of the voltage output of inverter must be area-symmetric and the design of the inverter must have specifications for the modularized lamp. The performance of the Backlight, such as lifetime or brightness, is greatly influenced by the characteristics of the DC-AC inverter for the lamp. All the parameters of an inverter should be carefully designed to avoid generating too much current leakage from high voltage output of the inverter. When designing or ordering the inverter please make sure that a poor lighting caused by the mismatch of the Backlight and the inverter (miss-lighting, flicker, etc.) never occurs. If the above situation is confirmed, the module should be operated in the same manners when it is installed in your instrument.

The output of the inverter must have symmetrical (negative and positive) voltage waveform and symmetrical current waveform. (Unsymmetrical ratio is less than 10%) Please do not use the inverter which has unsymmetrical voltage and unsymmetrical current and spike wave. Lamp frequency may produce interface with horizontal synchronous frequency and as a result this may cause beat on the display. Therefore lamp frequency shall be as away possible from the horizontal synchronous frequency and from its harmonics in order to prevent interference.

Requirements for a system inverter design, which is intended to have a better display performance, a better power efficiency and a more reliable lamp. It shall help increase the lamp lifetime and reduce its leakage current.

- a. The asymmetry rate of the inverter waveform should be 10% below;
- b. The distortion rate of the waveform should be within $\sqrt{2} \pm 10\%$;
- c. The ideal sine wave form shall be symmetric in positive and negative polarities.

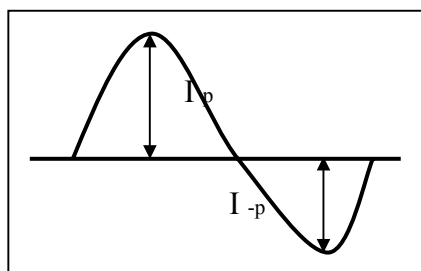

* Asymmetry rate:

$$\frac{|I_p - I_{-p}|}{I_{\text{rms}}} * 100\%$$

* Distortion rate

$$I_p \text{ (or } I_{-p}) / I_{\text{rms}}$$

4. BLOCK DIAGRAM

4.1 TFT LCD MODULE

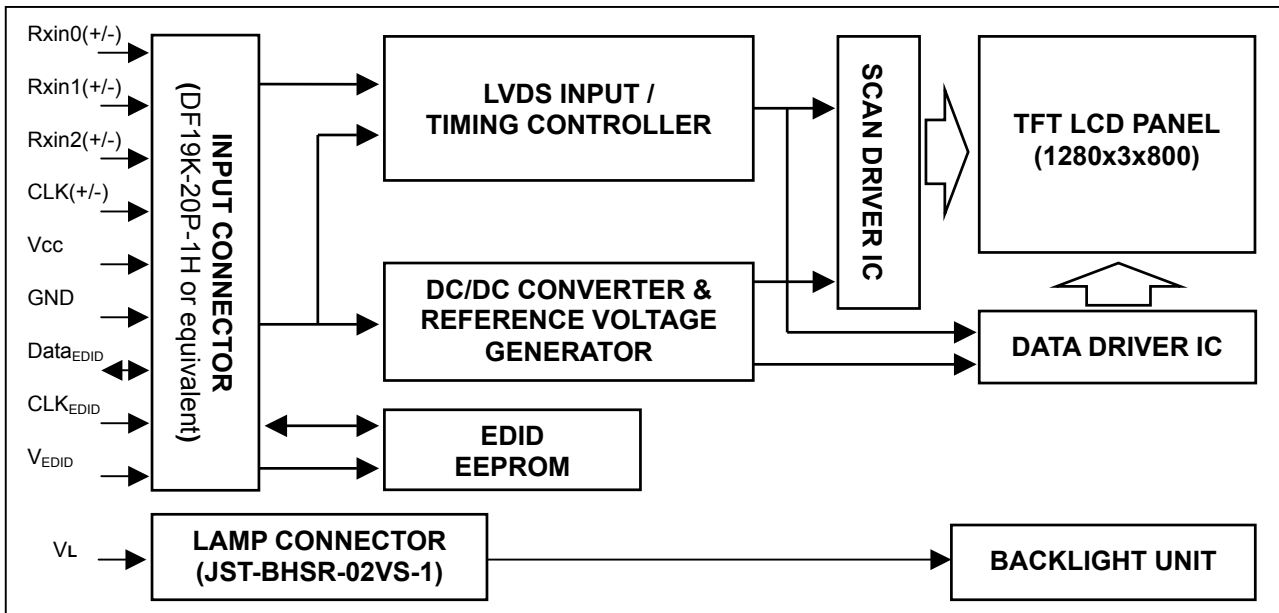

4.2 BACKLIGHT UNIT

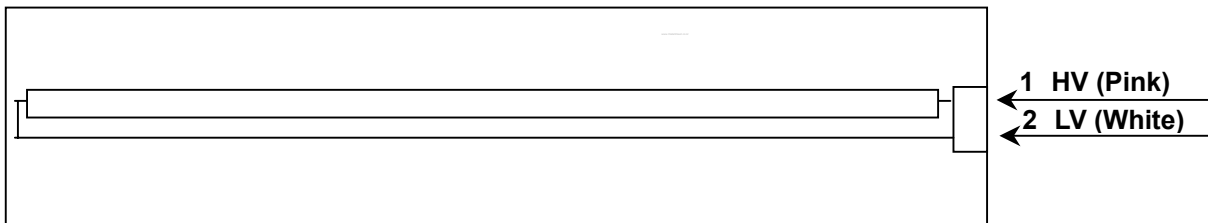

5. INPUT TERMINAL PIN ASSIGNMENT

5.1 TFT LCD MODULE

Pin	Symbol	Description	Polarity	Remark
1	VDD	Power Supply +3.3 V		-
2	VDD	Power Supply +3.3 V		-
3	GND	Ground		-
4	GND	Ground		
5	Rxin0-	LVDS Differential Data Input	Negative	R0~R5,G0-
6	Rxin0+	LVDS Differential Data Input	Positive	
7	GND	Ground		
8	Rxin1-	LVDS Differential Data Input	Negative	G1~G5,B0,B1
9	Rxin1+	LVDS Differential Data Input	Positive	
10	GND	Ground		
11	Rxin2-	LVDS Differential Data Input	Negative	B2~B5,Hsync,Vsync,DE
12	Rxin2+	LVDS Differential Data Input	Positive	
13	GND	Ground		
14	CLK-	LVDS Clock Data Input	Negative	LVDS Level
15	CLK+	LVDS Clock Data Input	Positive	
16	GND	Ground		
17	V _{EDID}	DDC +3.3 V		
18	NC			
19	CLK _{EDID}	DDC Clock		
20	Data _{EDID}	DDC Data	-	-

Note (1) Connector Part No.: DF19K-20P-1H or equivalent

Note (2) User's connector Part No: DF19G-20S-1C or equivalent

5.2 BACKLIGHT UNIT

Pin	Symbol	Description	Color
1	HV	High Voltage	Pink
2	LV	Ground	White

Note (1) Connector Part No.: JST-BHSR-02VS-1 or equivalent

Note (2) User's connector Part No.: JST-SM02B-BHSS-1-TB or equivalent

5.3 TIMING DIAGRAM OF LVDS INPUT SIGNAL

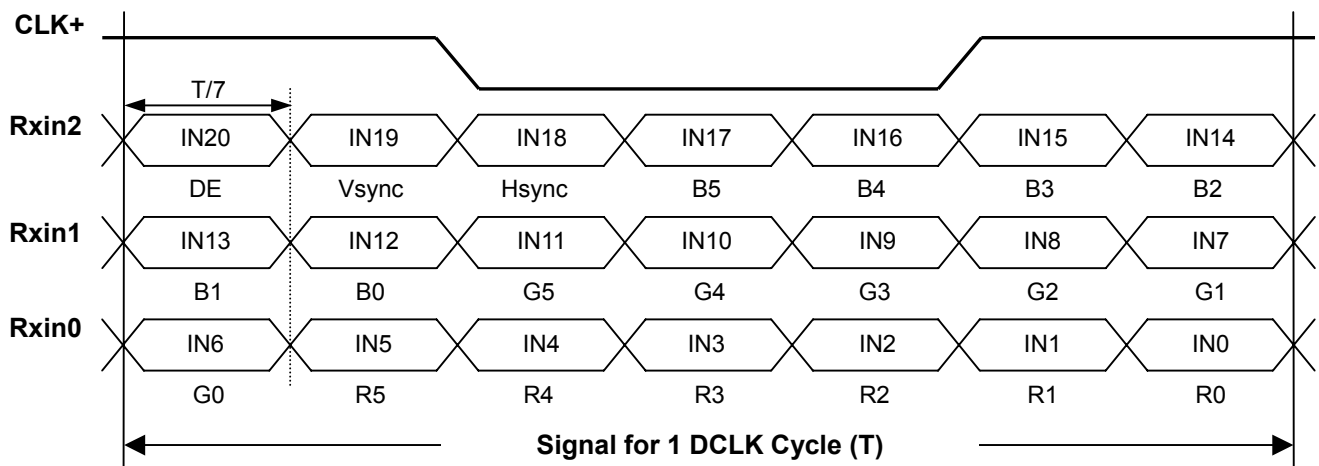

5.4 COLOR DATA INPUT ASSIGNMENT

The brightness of each primary color (red, green and blue) is based on the 6-bit gray scale data input for the color. The higher the binary input the brighter the color. The table below provides the assignment of color versus data input.

Color		Data Signal																	
		Red						Green						Blue					
		R5	R4	R3	R2	R1	R0	G5	G4	G3	G2	G1	G0	B5	B4	B3	B2	B1	B0
Basic Colors	Black	0	0	0	0	0	0	0	0	0	0	0	0	0	0	0	0	0	0
	Red	1	1	1	1	1	1	0	0	0	0	0	0	0	0	0	0	0	0
	Green	0	0	0	0	0	0	1	1	1	1	1	1	0	0	0	0	0	0
	Blue	0	0	0	0	0	0	0	0	0	0	0	0	1	1	1	1	1	1
	Cyan	0	0	0	0	0	0	1	1	1	1	1	1	1	1	1	1	1	1
	Magenta	1	1	1	1	1	1	0	0	0	0	0	0	0	1	1	1	1	1
	Yellow	1	1	1	1	1	1	1	1	1	1	1	1	0	0	0	0	0	0
	White	1	1	1	1	1	1	1	1	1	1	1	1	1	1	1	1	1	1
Gray Scale Of Red	Red(0)/Dark	0	0	0	0	0	0	0	0	0	0	0	0	0	0	0	0	0	0
	Red(1)	0	0	0	0	0	1	0	0	0	0	0	0	0	0	0	0	0	0
	Red(2)	0	0	0	0	1	0	0	0	0	0	0	0	0	0	0	0	0	0
	:	:	:	:	:	:	:	:	:	:	:	:	:	:	:	:	:	:	:
	:	:	:	:	:	:	:	:	:	:	:	:	:	:	:	:	:	:	:
	:	:	:	:	:	:	:	:	:	:	:	:	:	:	:	:	:	:	:
	Red(61)	1	1	1	1	0	1	0	0	0	0	0	0	0	0	0	0	0	0
	Red(62)	1	1	1	1	1	0	0	0	0	0	0	0	0	0	0	0	0	0
Red(63)	1	1	1	1	1	1	0	0	0	0	0	0	0	0	0	0	0	0	
Gray Scale Of Green	Green(0)/Dark	0	0	0	0	0	0	0	0	0	0	0	0	0	0	0	0	0	0
	Green(1)	0	0	0	0	0	0	0	0	0	0	0	1	0	0	0	0	0	0
	Green(2)	0	0	0	0	0	0	0	0	0	0	1	0	0	0	0	0	0	0
	:	:	:	:	:	:	:	:	:	:	:	:	:	:	:	:	:	:	:
	:	:	:	:	:	:	:	:	:	:	:	:	:	:	:	:	:	:	:
	:	:	:	:	:	:	:	:	:	:	:	:	:	:	:	:	:	:	:
	Green(61)	0	0	0	0	0	0	1	1	1	1	0	1	0	0	0	0	0	0
	Green(62)	0	0	0	0	0	0	1	1	1	1	1	0	0	0	0	0	0	0
Green(63)	0	0	0	0	0	0	1	1	1	1	1	1	0	0	0	0	0	0	
Gray Scale Of Blue	Blue(0)/Dark	0	0	0	0	0	0	0	0	0	0	0	0	0	0	0	0	0	0
	Blue(1)	0	0	0	0	0	0	0	0	0	0	0	0	0	0	0	0	0	1
	Blue(2)	0	0	0	0	0	0	0	0	0	0	0	0	0	0	0	0	1	0
	:	:	:	:	:	:	:	:	:	:	:	:	:	:	:	:	:	:	:
	:	:	:	:	:	:	:	:	:	:	:	:	:	:	:	:	:	:	:
	:	:	:	:	:	:	:	:	:	:	:	:	:	:	:	:	:	:	:
	Blue(61)	0	0	0	0	0	0	0	0	0	0	0	0	1	1	1	1	0	1
	Blue(62)	0	0	0	0	0	0	0	0	0	0	0	0	1	1	1	1	1	0
Blue(63)	0	0	0	0	0	0	0	0	0	0	0	0	1	1	1	1	1	1	

Note (1) 0: Low Level Voltage, 1: High Level Voltage

5.5 EDID DATA STRUCTURE

The EDID (Extended Display Identification Data) data formats are to support displays as defined in the VESA Plug & Display and FPD1 standards.

Byte # (decimal)	Byte # (hex)	Field Name and Comments	Value (hex)	Value (binary)
0	0	Header , Fixed	00	00000000
1	1	Header , Fixed	FF	11111111
2	2	Header , Fixed	FF	11111111
3	3	Header , Fixed	FF	11111111
4	4	Header , Fixed	FF	11111111
5	5	Header , Fixed	FF	11111111
6	6	Header , Fixed	FF	11111111
7	7	Header , Fixed	00	00000000
8	8	EISA Mfg. Code LSB 3 character in compressed ASCII: "CMO" -> 0D AF	0D	00001101
9	9	EISA Mfg. Code LSB 3 character in compressed ASCII: "CMO" -> 0D AF	AF	10101111
10	0A	Product code 1500, (hex, LSB first)	01	00000001
11	0B	Product code 1500, (hex, LSB first)	12	00010010
12	0C	32-bit serial # Unused(01h for VESA, 00h for SPWG)	00	00000000
13	0D	32-bit serial # Unused(01h for VESA, 00h for SPWG)	00	00000000
14	0E	32-bit serial # Unused(01h for VESA, 00h for SPWG)	00	00000000
15	0F	32-bit serial # Unused(01h for VESA, 00h for SPWG)	00	00000000
16	10	Week of manufacture 1 - 53 (unused: 00h) : 02h fixed by CMO	00	00000000
17	11	Year of manufacture year - 1990(unsed:00h) : 0Dh (Year 2003) fixed by CMO	00	00000000
18	12	Version=1	01	00000001
19	13	Revision=3	03	00000011
20	14	Digital	80	10000000
21	15	Active area horizontal 26.112cm	1A	00011010
22	16	Active area vertical 16.32cm	10	00010000
23	17	gamma * 100-100 = 2.2*100-100=120	78	01111000
24	18	Feature support (no DPMS, Active off, RGB, Preferred Timing Mode)	0A	00001010
25	19	Rx1 Rx0 Ry1 Ry0 Gx1 Gx0 Gy1 Gy0	BB	10111011
26	1A	Bx1 Bx0 By1 By0 Wx1 Wx0 Wy1 Wy0	80	10000000
27	1B	Rx=0.573	92	10010010
28	1C	Ry=0.339	56	01010110
29	1D	Gx=0.327	53	01010011
30	1E	Gy=0.566	90	10010000
31	1F	Bx=0.151	26	00100110
32	20	By=0.125	20	00100000
33	21	Wx=0.313	50	01010000
34	22	Wy=0.329	54	01010100
35	23	Not supported	00	00000000
36	24	Not supported	00	00000000
37	25	No manufacturer's specific timing	00	00000000

Byte # (decimal)	Byte # (hex)	Field Name and Comments	Value (hex)	Value (binary)
38	26	01h: Blank	01	00000001
39	27	01h: Blank	01	00000001
40	28	01h: Blank	01	00000001
41	29	01h: Blank	01	00000001
42	2A	01h: Blank	01	00000001
43	2B	01h: Blank	01	00000001
44	2C	01h: Blank	01	00000001
45	2D	01h: Blank	01	00000001
46	2E	01h: Blank	01	00000001
47	2F	01h: Blank	01	00000001
48	30	01h: Blank	01	00000001
49	31	01h: Blank	01	00000001
50	32	01h: Blank	01	00000001
51	33	01h: Blank	01	00000001
52	34	01h: Blank	01	00000001
53	35	01h: Blank	01	00000001
54	36	Pixel clock/10000(LSB first)	BC	10111100
55	37	71MHz/10000 = 7100 = 1BBCh	1B	00011011
56	38	HActive(D7-D0) = 1280 mod 256	00	00000000
57	39	HBlank(D7-D0) = 160 mod 256	A0	10100000
58	3A	HActive(D11-D8) : HBlank(D11-D8) = 1280/256 : 160/256	50	01010000
59	3B	VActive(D7-D0) = 800 mod 256	20	00100000
60	3C	VBlank(D7-D0) = 23 mod 256	17	00010111
61	3D	VActive(D11-D8) : VBlank(D11-D8) = 800/256 : 23/256	30	00110000
62	3E	HSyncOffset(D7-D0) = HBorder+HFrontPorch = 48	30	00110000
63	3F	HSyncWidth(D7-D0) = 32	20	00100000
64	40	VSynOffset(D3-D0) : VSynWidth(D3-D0)	36	00110110
65	41	HSyncOffset(D9-D8) : HSyncWidth(D9-D8) : VSynOffset(D5-D4) : VSynWidth(D5-D4)	00	00000000
66	42	HImageSize(mm, D7-D0) = 261mod 256	05	00000101
67	43	VImageSize(mm, D7-D0) = 163mod 256	A3	10100011
68	44	HImageSize(D11-D8) : VImageSize(D11-D8) = 261/256 : 163/256	10	00010000
69	45	Hborder=0	00	00000000
70	46	Vborder=0	00	00000000
71	47	Non-interlaced, Normal Display, Digital separate, Positive Hsync, Negative Vsync	18	00011000
72	48	Flag	00	00000000
73	49	Flag	00	00000000
74	4A	Flag	00	00000000
75	4B	Data type tag : ASCII string (FEh)	FE	11111110
76	4C	Flag	00	00000000
77	4D	"N"	4E	01001110
78	4E	"1"	31	00110001
79	4F	"2"	32	00110010
80	50	"1"	31	00110001
81	51	"I"	49	01001001

Byte # (decimal)	Byte # (hex)	Field Name and Comments	Value (hex)	Value (binary)
82	52	"1"	31	00110001
83	53	Terminator: 0Ah	0A	00001010
84	54	20h	20	00100000
85	55	20h	20	00100000
86	56	20h	20	00100000
87	57	20h	20	00100000
88	58	20h	20	00100000
89	59	20h	20	00100000
90	5A	Flag	00	00000000
91	5B	Flag	00	00000000
92	5C	Flag	00	00000000
93	5D	Data type tag : ASCII string (FEh)	FE	11111110
94	5E	Flag	00	00000000
95	5F	"N"	4E	01001110
96	60	"1"	31	00110001
97	61	"2"	32	00110010
98	62	"1"	31	00110001
99	63	"I"	49	01001001
100	64	"1"	31	00110001
101	65	Terminator: 0Ah	0A	00001010
102	66	padding: 20h	20	00100000
103	67	padding: 20h	20	00100000
104	68	padding: 20h	20	00100000
105	69	padding: 20h	20	00100000
106	6A	padding: 20h	20	00100000
107	6B	padding: 20h	20	00100000
108	6C	Flag	00	00000000
109	6D	Flag	00	00000000
110	6E	Flag	00	00000000
111	6F	Data type tag : Monitor Name as ASCII string (FCh)	FC	11111100
112	70	Flag	00	00000000
113	71	"C"	43	01000011
114	72	"o"	6F	01101111
115	73	"I"	6C	01101100
116	74	"o"	6F	01101111
117	75	"r"	72	01110010
118	76	" "	20	00100000
119	77	"L"	4C	01001100
120	78	"C"	43	01000011
121	79	"D"	44	01000100
122	7A	Terminator: 0Ah	0A	00001010
123	7B	padding: 20h	20	00100000
124	7C	padding: 20h	20	00100000
125	7D	padding: 20h	20	00100000
126	7E	No extension	00	00000000
127	7F	One-byte checksum of entire 128 bytes EDID equals 00h.	E3	11100011

5.6 EDID SIGNAL SPECIFICATION

(1) EDID Power

Parameter	Symbol	Test Condition	Min.	Typ.	Max.	Unit
Power supply voltage	Vcc	—	1.8	—	5.5	V

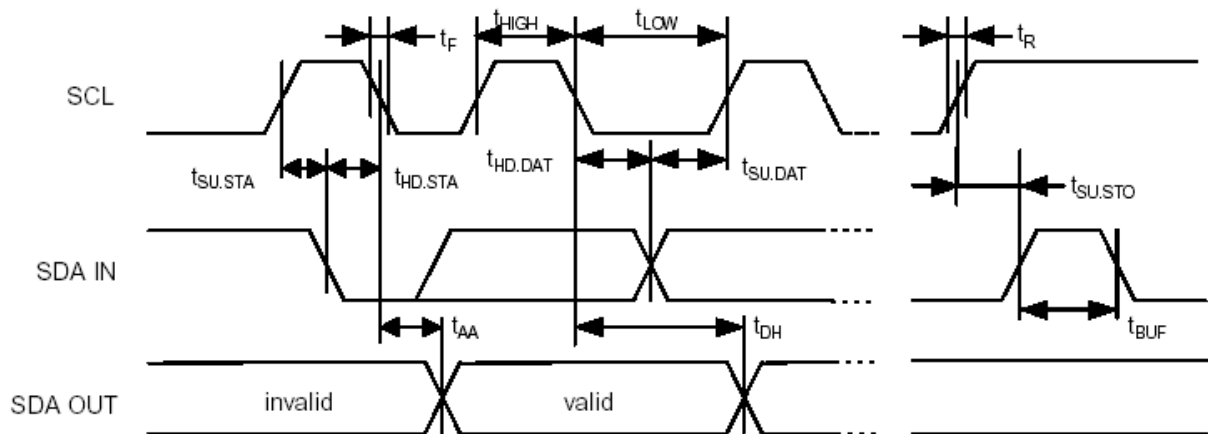

(2) DC characteristics

Parameter	Symbol	Test Condition	Min	Typ	Max	Unit
Supply current Vcc=5.0V	Icc	READ at 100kHz	—	0.4	1.0	mA
Supply current Vcc=5.0V	Icc	WRITE at 100kHz	—	2.0	3.0	mA
Standby Current	ISB	Vin=Vcc or Vss	—	1.6	4.0	μA
Input Leakage Current	ILI	Vin=Vcc or Vss	—	0.1	10	μA
Onput Leakage Current	ILO	Vout=Vcc or Vss	—	0.1	10	μA
Input Low Level	VIL	—	-1.0	—	Vcc x 0.3	V
Input High Level	VIH	—	Vcc x 0.7	—	Vcc+0.5	V
Output Low Level Vcc=3.0V	VOL1	IOL=3mA	—	—	0.4	V
Output Low Level Vcc=1.8V	VOL2	IOL=1.5mA	—	—	0.5	V

(3) AC characteristics (VCC=1.8~5.5V standard operation mode)

Parameter	Symbol	Min	Max	Unit
Clock Frequency, SCL	F _{SCL}	—	100	kHz
Clock Pulse Width Low	T _{LOW}	4.7	—	μs
Clock Pulse Width High	T _{HIGH}	4.0	—	μs
Noise Suppression Time	T _I	—	100	ns
Clock Low to Data Out Valid	T _{AA}	0.1	4.5	μs
Time the bus must be free before a new transmission can start	T _{BUF}	4.7	—	μs
Start Hold Time	T _{HD.STA}	4.7	—	μs
Start Set-up Time	T _{SU.STA}	4.7	—	μs
Data in Hold Time	T _{HD.DAT}	0	—	μs
Data in Set-up Time	T _{SU.DAT}	200	—	ns
Inputs Rise Time	T _R	—	1.0	μs
Inputs Fall Time	T _F	—	300	ns
Stop Set-up Time	T _{SU.STO}	4.7	—	μs
Data Out Hold Time	T _{DH}	100	—	ns
Write Cycle Time	T _{WR}	—	10	ms

6. INTERFACE TIMING

6.1 INPUT SIGNAL TIMING SPECIFICATIONS

The input signal timing specifications are shown as the following table and timing diagram.

Signal	Item	Symbol	Min.	Typ.	Max.	Unit	Note
DCLK	Frequency	1/Tc	-	71	80	MHz	-
DE	Vertical Total Time	T _v	802	823	1050	TH	-
	Vertical Addressing Time	T _{vD}	800	800	800	TH	-
	Horizontal Total Time	T _H	1380	1440	1680	Tc	-
	Horizontal Addressing Time	T _{HD}	1280	1280	1280	Tc	-

INPUT SIGNAL TIMING DIAGRAM

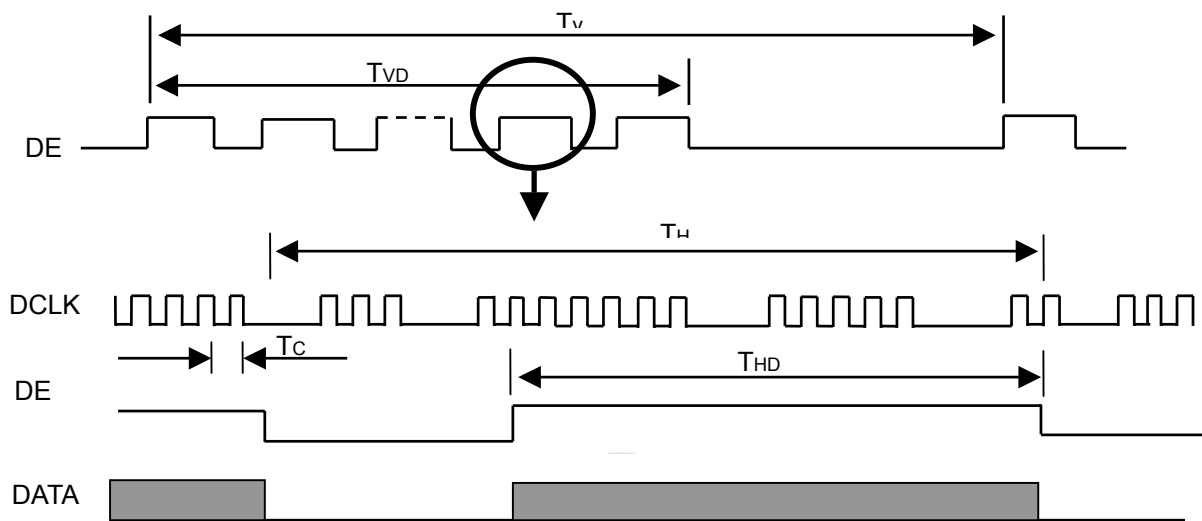

6.2 POWER ON/OFF SEQUENCE

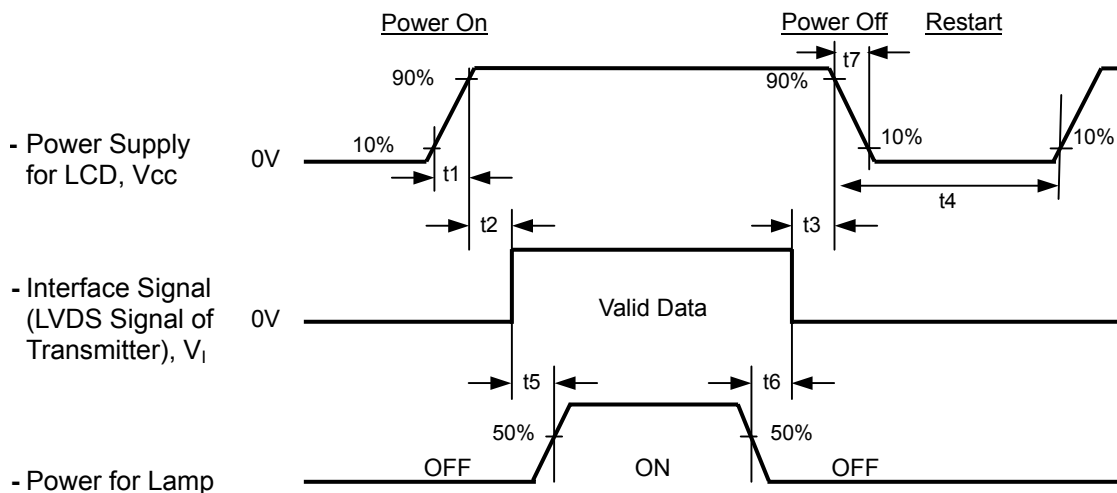

Timing Specifications:

$$0.5\text{ms} < t_1 \leq 10 \text{ msec}$$

$$0 < t_2 \leq 50 \text{ msec}$$

$$0 < t_3 \leq 50 \text{ msec}$$

$$t_4 \geq 500 \text{ msec}$$

$$t_5 \geq 200 \text{ msec}$$

$$t_6 \geq 200 \text{ msec}$$

Note (1) Please avoid floating state of interface signal at invalid period.

Note (2) When the interface signal is invalid, be sure to pull down the power supply of LCD Vcc to 0 V.

Note (3) The Backlight inverter power must be turned on after the power supply for the logic and the interface signal is valid. The Backlight inverter power must be turned off before the power supply for the logic and the interface signal is invalid.

Note (4) Sometimes some slight noise shows when LCD is turned off (even backlight is already off). To avoid this phenomenon, we suggest that the Vcc falling time had better to follow

$$t_7 \geq 5 \text{ msec}$$

7. OPTICAL CHARACTERISTICS

7.1 TEST CONDITIONS

Item	Symbol	Value	Unit
Ambient Temperature	T _a	25±2	°C
Ambient Humidity	H _a	50±10	%RH
Supply Voltage	V _{CC}	3.3	V
Input Signal	According to typical value in "3. ELECTRICAL CHARACTERISTICS"		
Inverter Current	I _L	6.0	mA
Inverter Driving Frequency	F _L	55	KHz
Inverter	Sumida-H05-4915		

The measurement methods of optical characteristics are shown in Section 7.2. The following items should be measured under the test conditions described in Section 7.1 and stable environment shown in Note (6).

7.2 OPTICAL SPECIFICATIONS

Item	Symbol	Condition	Min.	Typ.	Max.	Unit	Note	
Contrast Ratio	CR	$\theta_x=0^\circ, \theta_y=0^\circ$ Viewing Normal Angle	300	500	-	-	(2), (6)	
Response Time	T _R		-	8	10	ms	(3)	
	T _F		-	17	25	ms		
Average Luminance of White	L _{AVE}		180	200	-	cd/m ²	(4), (6)	
White Variation	δW		-	-	1.4	-	(6), (7)	
Cross Talk	CT		-	-	4.0	%	(5), (6)	
Color Chromaticity	Red		R _x	0.538	0.568	0.598	-	(1), (6)
			R _y	0.316	0.346	0.376	-	
	Green		G _x	0.289	0.319	0.349	-	
			G _y	0.549	0.579	0.609	-	
	Blue	B _x	0.122	0.152	0.182	-		
		B _y	0.102	0.132	0.162	-		
White	W _x	0.283	0.313	0.343	-			
	W _y	0.299	0.329	0.359	-			
Viewing Angle	Horizontal	θ_{x+}	40	45	-	Deg.	(1), (6)	
		θ_{x-}	40	45	-			
	Vertical	θ_{y+}	15	20	-			
		θ_{y-}	40	45	-			

Note (1) Definition of Viewing Angle (θ_x, θ_y):

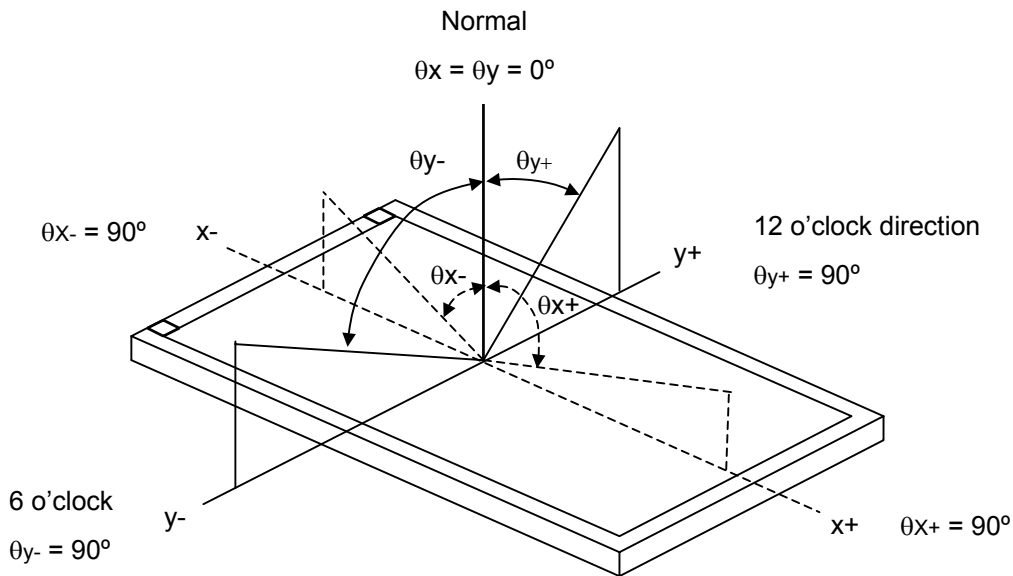

Note (2) Definition of Contrast Ratio (CR):

The contrast ratio can be calculated by the following expression.

$$\text{Contrast Ratio (CR)} = L_{63} / L_0$$

L63: Luminance of gray level 63

L 0: Luminance of gray level 0

$$CR = CR(5)$$

CR (X) is corresponding to the Contrast Ratio of the point X at Figure in Note (7).

Note (3) Definition of Response Time (T_R, T_F):

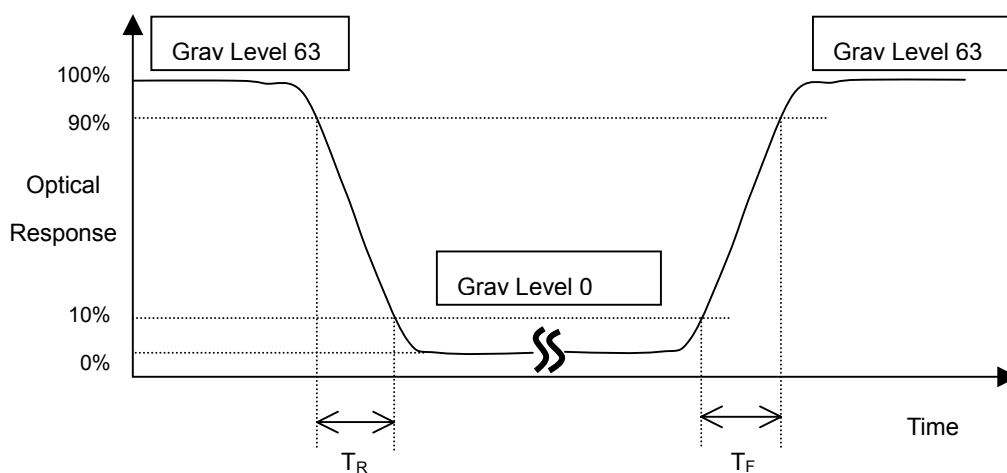

Note (4) Definition of Average Luminance of White (L_{AVE}):

Measure the luminance of gray level 63 at 5 points

$$L_{AVE} = [L(1) + L(2) + L(3) + L(4) + L(5)] / 5$$

$L(x)$ is corresponding to the luminance of the point X at Figure in Note (7).

Note (5) Definition of Cross Talk (CT):

$$CT = |Y_B - Y_A| / Y_A \times 100 (\%)$$

Where:

Y_A = Luminance of measured location without gray level 0 pattern (cd/m^2)

Y_B = Luminance of measured location with gray level 0 pattern (cd/m^2)

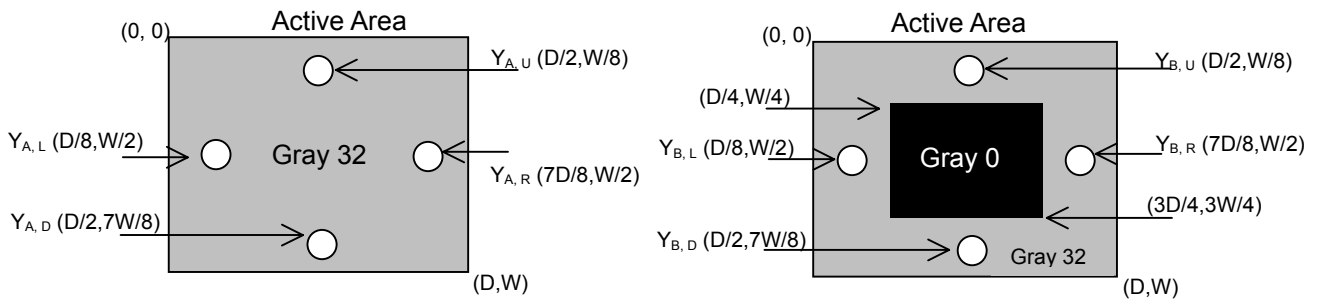

Note (6) Measurement Setup:

The LCD module should be stabilized at given temperature for 20 minutes to avoid abrupt temperature change during measuring. In order to stabilize the luminance, the measurement should be executed after lighting Backlight for 20 minutes in a windless room.

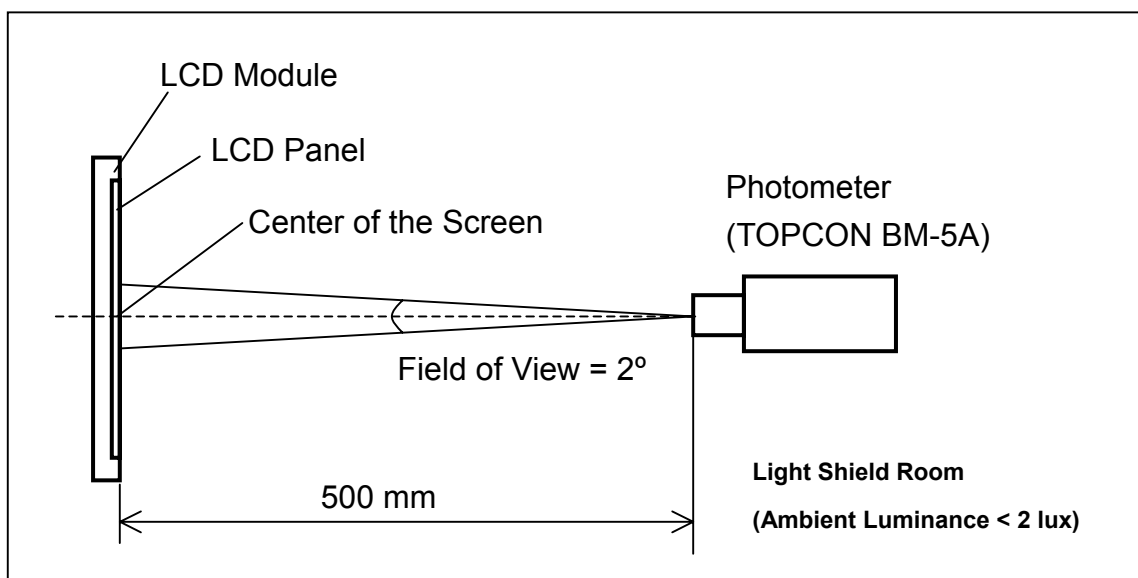

Note (7) Definition of White Variation (δW):

Measure the luminance of gray level 63 at 5 points

$$\delta W = \text{Maximum [L (1), L (2), L (3), L (4), L (5)] / Minimum [L (1), L (2), L (3), L (4), L (5)]}$$

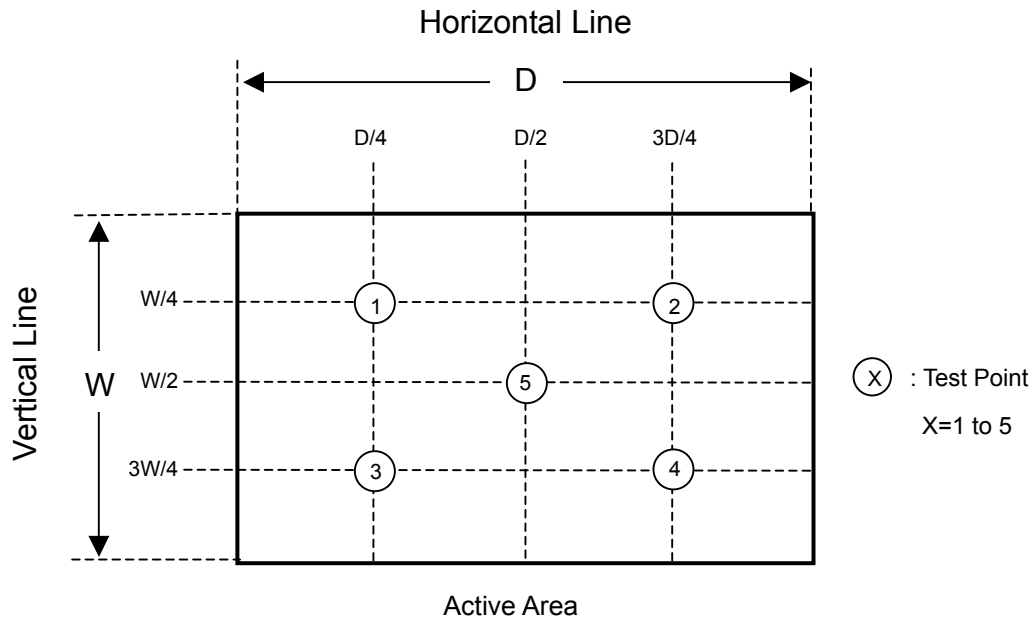

8. PRECAUTIONS

8.1 HANDLING PRECAUTIONS

- (1) The module should be assembled into the system firmly by using every mounting hole. Be careful not to twist or bend the module.
- (2) While assembling or installing modules, it can only be in the clean area. The dust and oil may cause electrical short or damage the polarizer.
- (3) Use fingerstalls or soft gloves in order to keep display clean during the incoming inspection and assembly process.
- (4) Do not press or scratch the surface harder than a HB pencil lead on the panel because the polarizer is very soft and easily scratched.
- (5) If the surface of the polarizer is dirty, please clean it by some absorbent cotton or soft cloth. Do not use Ketone type materials (ex. Acetone), Ethyl alcohol, Toluene, Ethyl acid or Methyl chloride. It might permanently damage the polarizer due to chemical reaction.
- (6) Wipe off water droplets or oil immediately. Staining and discoloration may occur if they left on panel for a long time.
- (7) If the liquid crystal material leaks from the panel, it should be kept away from the eyes or mouth. In case of contacting with hands, legs or clothes, it must be washed away thoroughly with soap.
- (8) Protect the module from static electricity, it may cause damage to the C-MOS Gate Array IC.
- (9) Do not disassemble the module.
- (10) Do not pull or fold the lamp wire.
- (11) Pins of I/F connector should not be touched directly with bare hands.

8.2 STORAGE PRECAUTIONS

- (1) High temperature or humidity may reduce the performance of module. Please store LCD module within the specified storage conditions.
- (2) It is dangerous that moisture come into or contacted the LCD module, because the moisture may damage LCD module when it is operating.
- (3) It may reduce the display quality if the ambient temperature is lower than 10 °C. For example, the response time will become slowly, and the starting voltage of lamp will be higher than the room temperature.

8.3 OPERATION PRECAUTIONS

- (1) Do not pull the I/F connector in or out while the module is operating.
- (2) Always follow the correct power on/off sequence when LCD module is connecting and operating. This can prevent the CMOS LSI chips from damage during latch-up.
- (3) The startup voltage of Backlight is approximately 1000 Volts. It may cause electrical shock while assembling with inverter. Do not disassemble the module or insert anything into the Backlight unit.

9. PACKING
 9.1 CARTON

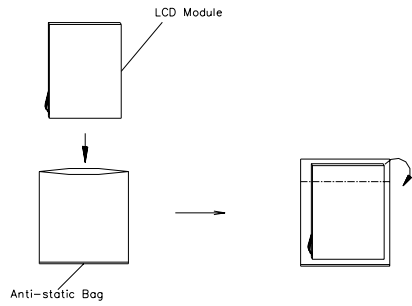

Box Dimensions: 489x(L)382x(W)x330(H)mm
 Weight: Approx . 9kg(20 module .per 1 box)

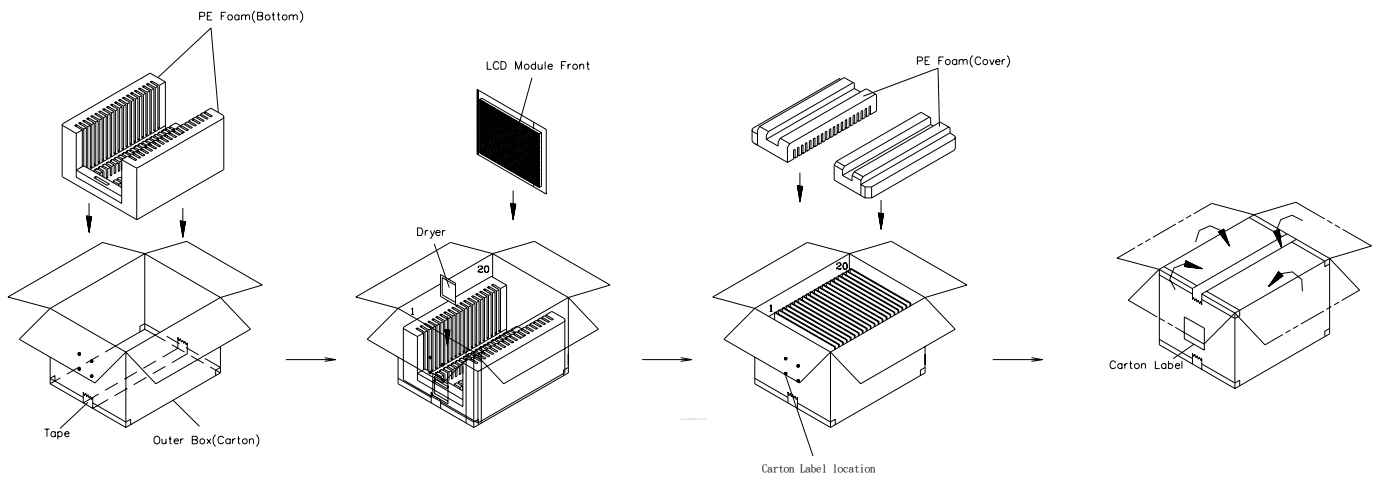

9.2 PALLET

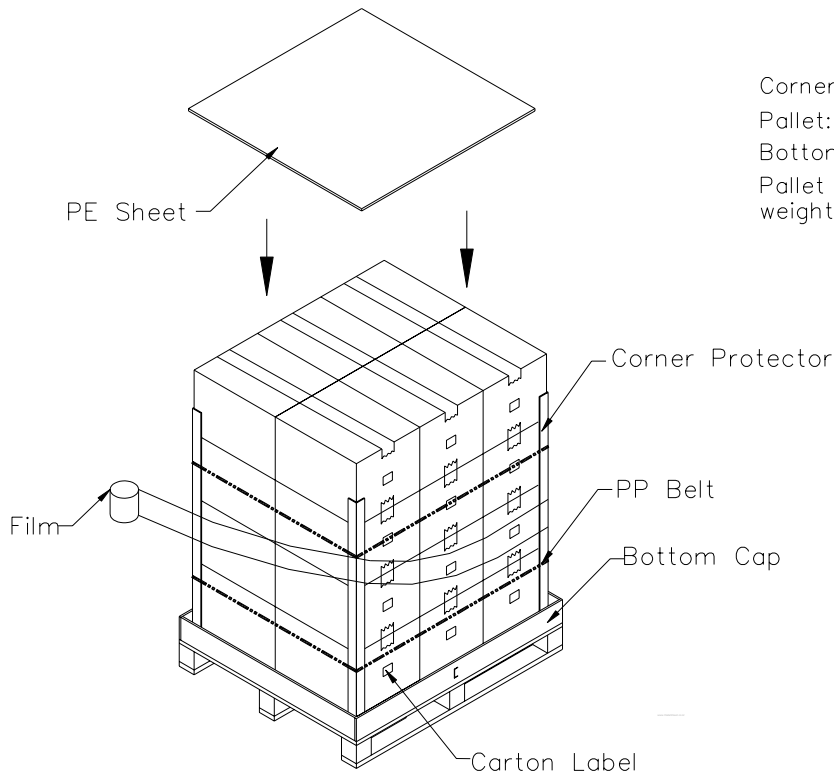

Corner Protector: L1250mm*50mm*50mm
Pallet: L1180*W1000*H135mm
Bottom Cap: L1180*W1000*H120mm
Pallet Stock Dim: L1180*W1000*H1465mm
weight: Approx.230kg

10. DEFINITION OF LABELS

10.1 CMO MODULE LABEL

The barcode nameplate is pasted on each module as illustration, and its definitions are as following explanation.

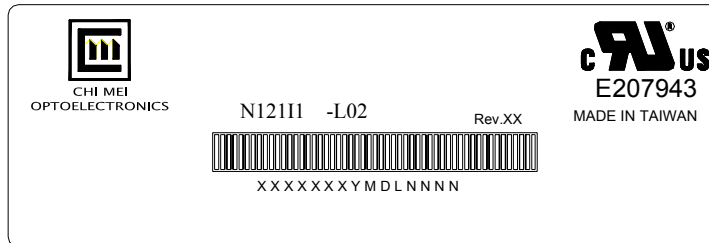

- (a) Model Name: N12111 - L02
- (b) Revision: Rev. XX, for example: C1, C2 ...etc.
- (c) Serial ID: XXXXXXXXYMDLNNNN

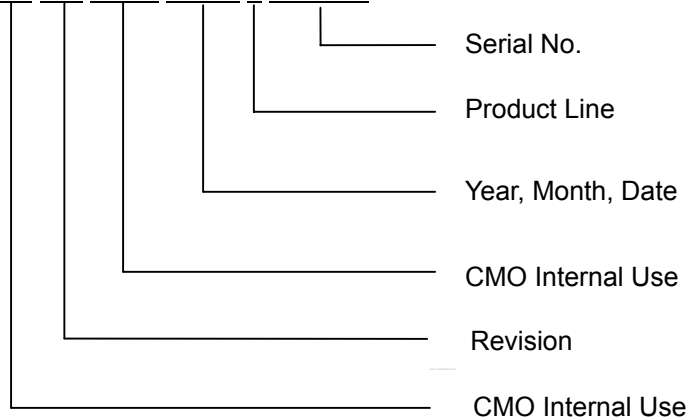

Serial ID includes the information as below:

- (a) Manufactured Date: Year: 1~9, for 2001~2009
 Month: 1~9, A~C, for Jan. ~ Dec.
 Day: 1~9, A~Y, for 1st to 31st, exclude I , O and U
- (b) Revision Code: cover all the change
- (c) Serial No.: Manufacturing sequence of product
- (d) Product Line: 1 -> Line1, 2 -> Line 2, ...etc.

10.2 CARTON LABEL

 CHI MEI OPTOELECTRONICS	
PO.NO. _____	
Part ID. _____	
Model Name _____	
Carton ID. _____	Quantities _____

