

SSM 2018



# Voltage-Controlled Amplifier/OVCE

## FEATURES

- Wide Dynamic Range
  - 118 dB typ (Class AB)
  - 108 dB typ (Class A)
- Wide Gain Range
  - 140 dB typ
- Excellent THD and IMD Performance Over Gain, Attenuation and Frequency
- Low Control Feedthrough
  - 1 mV typ (Class AB)
- Buffered Control Port and Current and Voltage Outputs
- Accepts Low or High Impedance Inputs
- Low External Parts Count
- Low Cost

## APPLICATIONS

- Voltage-Controlled Amplifiers
- Mixing Console Fader Automation Systems
- Compressors/Limiters
- Noise Gates
- Noise Reduction Systems
- Telephone Line Interfaces
- Automatic or Remote Volume Controllers
- Voltage-Controlled Equalizers
- Voltage-Controlled Panners

## GENERAL DESCRIPTION

The SSM-2018 voltage-controlled amplifier is an advanced integrated audio gain block featuring exceptional performance in voltage-controlled amplifier, panner, equalizer, and preamplifier functions. An extremely flexible architecture features inputs and outputs which can be configured for differential and single-ended signals, in both current and voltage modes. Also, the control port input and voltage outputs of the SSM-2018 are buffered, assuring optimal performance while significantly reducing the external parts count compared to other VCA products. The internal gain core can be programmed by the user for Class A, Class AB, or Intermediate operation by the selection of an external resistor. The SSM-2018 features excellent noise performance and exhibits negligible increase in distortion in Class AB operation over Class A, resulting in unusually low noise and distortion simultaneously.

SSM-2018 FUNCTIONAL DIAGRAM

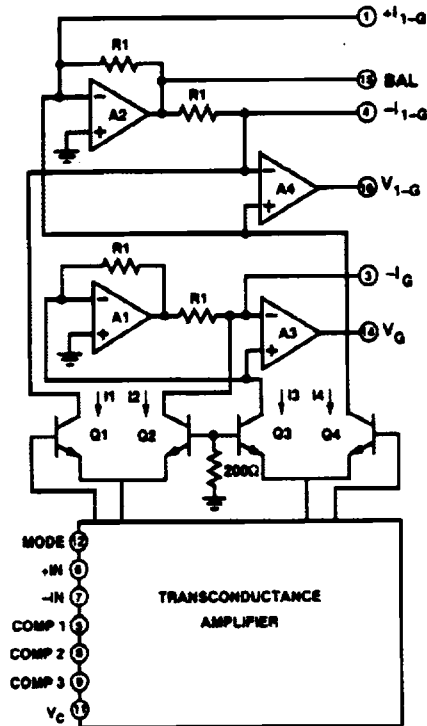

The SSM-2018's unique operational voltage-controlled element (OVCE) architecture is easily configured into many voltage-controlled functions by utilizing the simple feedback connections. Existing SSM-2014 sockets can be directly upgraded to the SSM-2018, with the additional benefit of a significant reduction in the number of external components needed to achieve full performance.

Combined with a voltage output DAC and multiplexed sample-and-hold circuit such as the DAC-7224 and SMP-08, or a multiple DAC such as the DAC-8800, high quality digital control of many audio functions can be realized with very low parts count, and at low cost.

Information furnished by Analog Devices is believed to be accurate and reliable. However, no responsibility is assumed by Analog Devices for its use; nor for any infringements of patents or other rights of third parties which may result from its use. No license is granted by implication or otherwise under any patent or patent rights of Analog Devices.

( $V_S = \pm 15\text{ V}$  and  $-40^\circ\text{C} \leq T_A \leq +85^\circ\text{C}$  with  $18\text{ k}\Omega$  feedback resistors, unless otherwise specified. Typical specifications apply to operation at  $T_A = +25^\circ\text{C}$ .)

# SSM-2018—SPECIFICATIONS

Parameters	Symbol	Conditions	Min	Typ	Max	Units
<b>INPUT AMPLIFIER</b>						
Bias Current	$I_B$	$V_{CM} = 0\text{ V}$		0.25	1	$\mu\text{A}$
Input Offset Voltage	$V_{IOS}$	$V_{CM} = 0\text{ V}$		1	20	mV
Input Offset Current	$I_{IOS}$	$V_{CM} = 0\text{ V}$		10	100	nA
Input Impedance	$Z_{IN}$			4		$\text{M}\Omega$
Equivalent Input Noise	$e_n$	$f = 1\text{ kHz}$		14		$\text{nV}/\sqrt{\text{Hz}}$
Common-Mode Range	CMR			+13, -13		V
Gain Bandwidth	GBW	VCA Configuration (See Figure 18) VCP Configuration (See Figure 22)		12		MHz
Slew Rate	SR	VCA Configuration (See Figure 18)		0.7		MHz
Supply Current	$I_{SY}$	No Load		10	15	$\text{V}/\mu\text{s}$ mA
<b>OUTPUT AMPLIFIERS</b>						
Offset Voltage	$V_{OOS}$	$V_{IN} = 0\text{ V}$		-1.0	20	mV
Minimum Load Resistor	$R_L$	For Full Output Swing		9		$\text{k}\Omega$
Output Voltage Swing		$I_{OUT} = 1.5\text{ mA}$	+10 -10	+13.0 -14.0		V V
<b>CONTROL PORT</b>						
Bias Current	$I_B$			0.36	1	$\mu\text{A}$
Input Impedance	$Z_{IN}$			1		$\text{M}\Omega$
Gain Constant	$G/(1-G)$	Ratio of Outputs		-28		$\text{mV}/\text{dB}$
Gain Constant Temperature Coefficient	$G/(1-G)_{TC}$			-2700		$\text{ppm}/^\circ\text{C}$
Control Feedthrough (Untrimmed) Class A		60 Hz Sine Wave Applied to Control Port, Causing -30 dB to +20 dB of Gain $f = 1\text{ kHz}, V_C = +4\text{ V}$		-10		mV
Class AB <sup>1</sup> Maximum Attenuation				-1	100	mV dB

## AUDIO SPECIFICATIONS<sup>2</sup>

Parameter	Conditions	Min	Typ	Max	Units
Noise					
Class A	$R_B = 30\text{ k}\Omega, BW = 20\text{ Hz} - 20\text{ kHz},$ $0\text{ dBV} = 1\text{ V}, A_V = 0\text{ dB}$		-88	-85	dBV
Class AB	$R_B = 150\text{ k}\Omega, BW = 20\text{ Hz} - 20\text{ kHz},$ $0\text{ dBV} = 1\text{ V}, A_V = 0\text{ dB}$		-97	-95	dBV
THD-A @ $A_V = 0\text{ dB}$	$R_B = 30\text{ k}\Omega, V_{IN} = +10\text{ dBV @ } 1\text{ kHz}$		0.006	0.015	%
THD-A @ $A_V = \pm 20\text{ dB}$	$R_B = 30\text{ k}\Omega, V_{IN} = +10\text{ dBV @ } 1\text{ kHz}$		0.009	0.025	%
THD-AB @ $A_V = 0\text{ dB}$	$R_B = 150\text{ k}\Omega, V_{IN} = +10\text{ dBV @ } 1\text{ kHz, w/Sym Trim}$		0.006	0.02	%
THD-AB @ $A_V = \pm 20\text{ dB}$	$R_B = 150\text{ k}\Omega, V_{IN} = +10\text{ dBV @ } 1\text{ kHz, w/Sym Trim}$		0.013	0.04	%

**NOTES**

<sup>1</sup>Symmetry trim only.

<sup>2</sup>Guaranteed specifications, based on characterization data.

Specifications subject to change without notice.

**ABSOLUTE MAXIMUM RATINGS\***

Supply Voltage	.....	±18 V
Input Voltage	.....	Supply Voltage
Junction Temperature	.....	+150°C
Operating Temperature Range	.....	-40°C to +85°C
Storage Temperature	.....	-65°C to +150°C
Lead Temperature (Soldering, 60 sec)	.....	+300°C

\*Stresses above those listed under "Absolute Maximum Ratings" may cause permanent damage to the device. These are stress ratings only; the functional operation of the device at these or any other conditions above those indicated in the operational sections of this specification is not implied. Exposure to absolute maximum rating conditions for extended periods may affect device reliability.

**Typical Performance Characteristics**

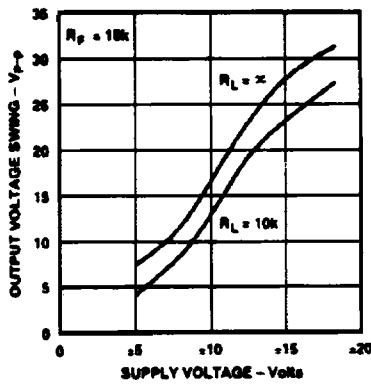

Figure 1. Maximum Output Swing vs. Supply Voltage

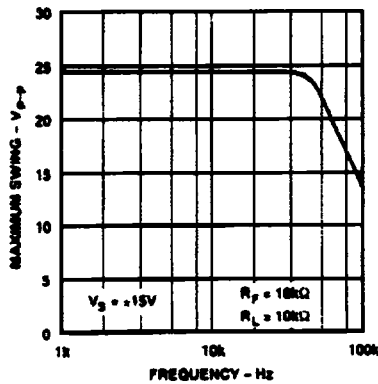

Figure 2. Maximum Output Swing vs. Frequency

**SSM-2018 PIN CONFIGURATION**  
 16-Pin Plastic Dip—P Suffix  
 16-Pin SOIC—S Suffix

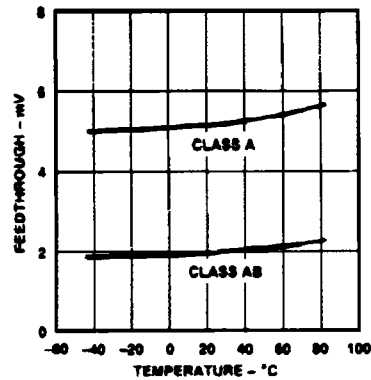
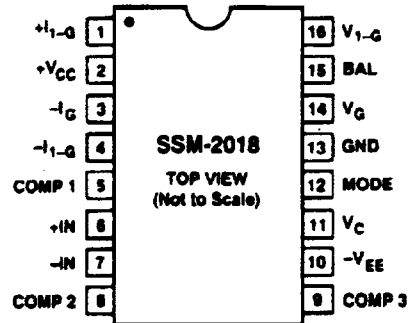

Figure 3. Trimmed Feedthrough vs. Temperature

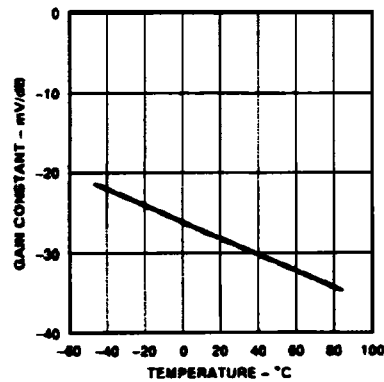

Figure 4. Gain Constant vs. Temperature

# SSM-2018

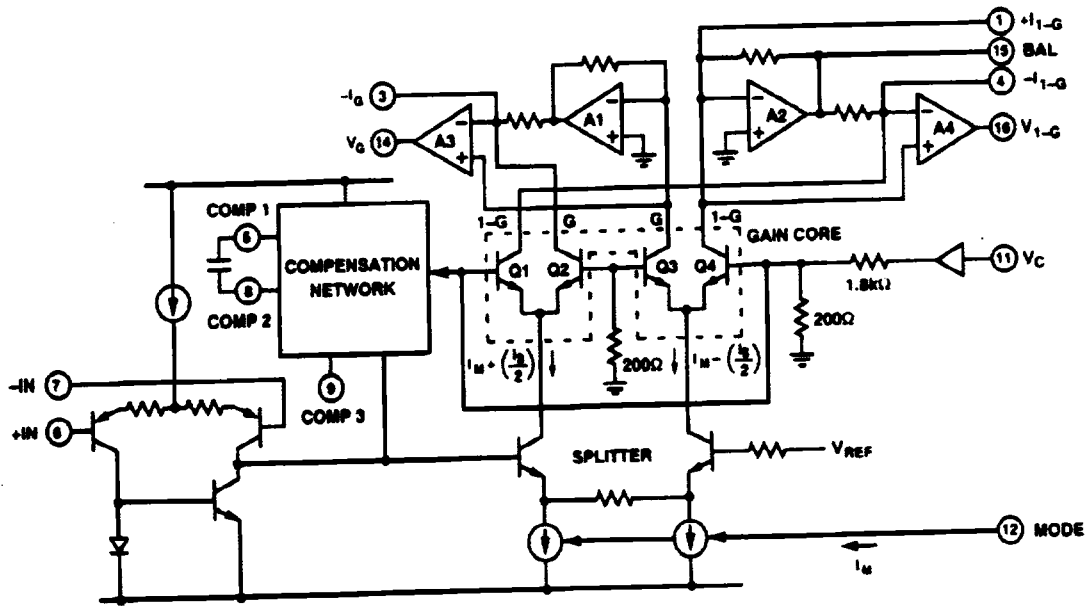

Figure 5. SSM-2018 Functional Diagram

## OPERATIONAL VOLTAGE-CONTROLLED ELEMENT THEORY OF OPERATION

The operational voltage-controlled element, or OVCE, is a new analog functional building block. It combines the function of an op amp and a voltage-controlled amplifier into a single integrated device. However, because of the special circuit topology used, this design offers higher performance than would be possible with two separate circuits. The OVCE can replace any VCA in any application simply by reconfiguring the external feedback connection. Additionally, it can perform numerous circuit functions not readily achievable with conventional VCAs.

As shown in Figure 5, the OVCE consists of three basic sections, which are:

1. The input differential pair, with compensation network;
2. A programmable current splitter which generates the biasing current for the gain core;
3. The four-transistor gain core (essentially a dual two-quadrant multiplier) and the output buffers.

The differential input pair structure is the same as that used in operational amplifiers, and generates a single-ended output current corresponding to the differential input voltage. Variable-gain amplifiers face a unique problem in maintaining optimal compensation over a wide range of selected gains. In the OVCE, an adaptive network following the input section effectively divides the external compensation capacitor by a value corresponding to the current value of VCA gain. In voltage-controlled potentiometer configurations, the adaptive network is not used because the global feedback is constant with changes in gain, requiring fixed compensation only.

The current generated by the input differential pair is split to drive the gain core transistors with currents containing equal and opposite signal components. The common-mode component of these currents ( $I_M$ ) determines the class of operation of the OVCE. This current corresponds to the current injected into

Pin 12, which is determined by a user-selected external bias resistor. Under small-signal conditions, there is a tradeoff between  $I_M$  and the noise produced in the gain core transistors.

The gain core consists of two very carefully matched differential pairs, utilizing large-geometry, high gain transistors designed to produce minimum noise and distortion. Examining Figure 6, it can be seen that a differential pair (which is forward-biased by the current source) divides the tail current  $I$  into two currents  $I_{C1}$  and  $I_{C2}$  according to the applied voltage  $V_B$ . With the high beta of these devices, we can assume that the emitter current is equal to the collector current, expressed as  $I_C = I_S \times \exp(aV_{BE})$ , where  $I_S$  is the reverse saturation current. Then, since  $I_{C1} + I_{C2} = I$  and  $V_B = V_{BE1} - V_{BE2}$ , the ratio of currents can be expressed as:

$$G = \frac{I_{C2}}{I} = \frac{\exp(aV_B)}{1 + \exp(aV_B)} \text{ and } 1 - G = \frac{I_{C1}}{I} = \frac{1}{1 + \exp(aV_B)}$$

These relationships are precisely reproduced in both pairs of the gain core, resulting in differential collector currents which accurately correspond to a function of the applied control voltage. The SSM-2018 is unique in providing both gain-multiplied and remainder-multiplied outputs, resulting in an infinitely flexible gain block.

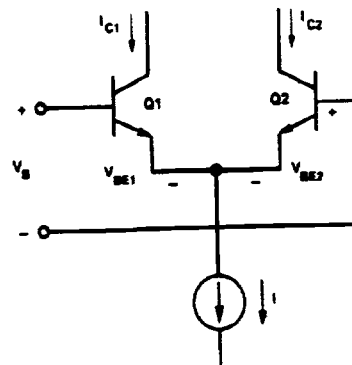

Figure 6. The OVCE Gain Core Differential Pair

The differential outputs of the gain core transistor pairs are applied to differential current-to-single ended voltage converters, composed of buffers A1 through A4 in Figure 5. Amplifiers A1 and A2 act as precision current mirrors, while A3 and A4 are current-to-voltage converters. Additionally, connections to A2 allow the user to balance the current mirror gain to achieve perfect symmetry in the positive and negative half-cycles of the output waveforms. Note that the noninverting inputs of A3 and A4 are connected to the inverting inputs of A1 and A2 respectively, thus cancelling the error contributions of the current mirror circuitry. For this reason it is recommended that in applications requiring additional output drive, external amplifiers be connected outside the feedback loops as voltage followers for best OVCE response and dynamic range.

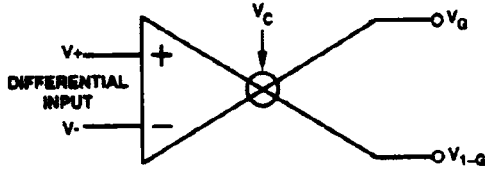

Figure 7. The OVCE Symbol

**USING THE OVCE**

The symbol for the OVCE is shown in Figure 7. The OVCE has two outputs,  $V_G$  and  $V_{1-G}$ . Both respond to the input, but in addition are in a ratio determined by the control port voltage,  $V_C$ , applied to Pin 11. Specifically,

$$V_G = (V(+)-V(-)) \times G \times A$$

and

$$V_{1-G} = (V(+)-V(-)) \times (1-G) \times A$$

where A is the open-loop gain of the circuit and

$$G = \frac{\exp(a \times V_C)}{1 + \exp(a \times V_C)}$$

As a result, the ratio of the outputs is

$$\frac{V_G}{V_{1-G}} = \exp(a \times V_C)$$

The control constant a is approximately -4 at room temperature.

Application circuits are easily understood if it is assumed that the voltages at the inputs of the OVCE are equal, as is commonly done with op amps when simplifying a negative-feedback circuit with high open-loop gain. Consider the basic follower/VCA connection for the OVCE shown in Figure 8. In this example, the input signal  $V_{IN}$  drives the noninverting input, and the  $V_{1-G}$  output is tied back to the inverting input. In closed-loop operation we can simplify by saying that the inputs are approximately equal, and so the  $V_{1-G}$  output follows the input for all control inputs. However, since from above

$$V_G = V_{1-G} \times \exp(a \times V_C)$$

then

$$V_G = V_{IN} \times \exp(a \times V_C)$$

Therefore, this OVCE configuration provides the function of a voltage follower at the  $V_{1-G}$  output, and the function of an exponential VCA at the  $V_G$  output. The direct feedback connection between the  $V_{1-G}$  output and the inverting input could be easily replaced with any general feedback network, as is commonly done in op amp circuits.

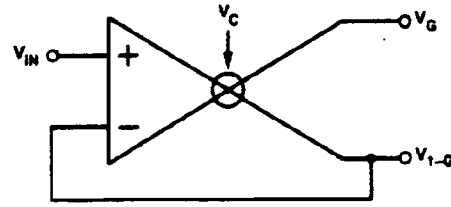
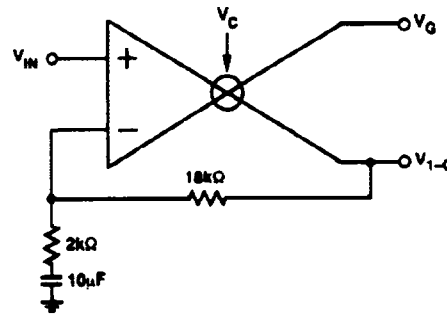
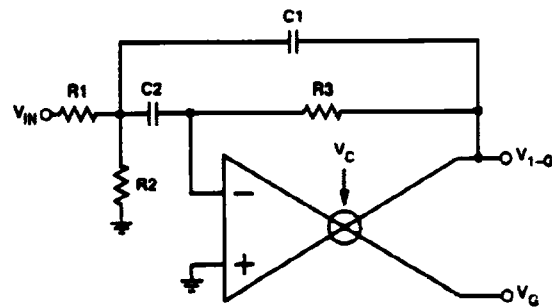

Figure 8. OVCE Follower/VCA Connection

A wide variety of transfer functions from the input to the  $V_{1-G}$  output are possible, independent of the control voltage input. At the same time, as discussed above the signal seen at the  $V_G$  output will then be equal to the transfer function times the control voltage exponential. As demonstrated in the two examples in Figure 9, this configuration provides the functions of both an operational amplifier and exponential VCA in a single device, allowing considerable flexibility in applications.



a. Voltage-Controlled Preamplifier



b. Voltage-Controlled Inverting Bandpass Filter

Figure 9. OVCE Configurations

# SSM-2018

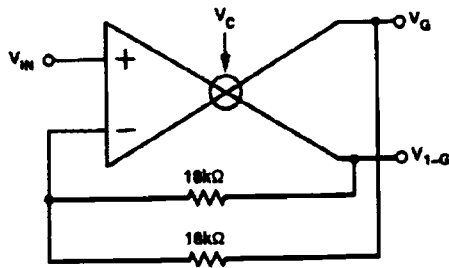

Figure 10. Basic VCP Connection

Figure 10 shows the OVCE configured with feedback applied from both outputs. Here the signal returned to the inverting input is one half of the sum of the two outputs, which must be equal to  $V_{IN}$  if we remember the approximation that the difference between the inputs is zero. The two outputs are then given by:

$$V_G = 2G \times V_{IN} \text{ and } V_{1-G} = 2(1 - G) \times V_{IN}$$

It can be seen that this provides a panning function as  $G$  ranges between 0 and 1 when  $V_C$  sweeps through its range. For instance, when  $V_C = 0$ ,  $V_G = V_{1-G} = V_{IN}$ . This configuration is called a voltage-controlled potentiometer (VCP). Note that the VCP shares the quasi-exponential gain characteristics of VCAs which operate as attenuators only. An endless variety of VCA and VCP configurations are possible using the SSM-2018, in both inverting and noninverting operation. The applications discussion below demonstrates the performance of a number of circuits.

### INPUT SECTION

The differential inputs are similar to those seen in an operational amplifier. The user may wish to utilize clamp diodes to avoid overdriving the input stage by high speed transients.

### SETTING THE GAIN CORE CLASS OF OPERATION

The mode of operation is determined by the user by programming the gain core bias current with resistor  $R_B$ . The positive supply can be used to provide a current into Pin 12, which must be between 90  $\mu A$  and 500  $\mu A$  for proper operation. The suggested value for the set resistor  $R_B$  is 30 k $\Omega$  for Class A operation and 150 k $\Omega$  for Class AB, noting that this input is approximately 0.7 V above ground. Without this current input, the output signal will appear half-wave rectified. In earlier designs, Class AB operation has always been preferred for lower noise operation, while Class A was the choice where distortion performance was the greater concern. However, as the distortion graphs below demonstrate, the SSM-2018 offers Class AB performance rivaling that of Class A. Most applications, except those demanding the lowest possible distortion performance, will bias the gain core as Class AB. Note that control feedthrough in the SSM-2018 will be significantly lower in Class AB operation. Alternatively, Intermediate Class operation offers an excellent compromise between the low noise of Class AB and the superior distortion of Class A.

### CONTROL SECTION

The sensitivity of the control port is -28 mV/dB at the input (Pin 11). A resistive divider is commonly used to scale the control voltage source range. Since this input can draw as much as 250 nA of bias current, it is recommended that the impedance

of the divider to ground be kept under 10 k $\Omega$  to minimize gain error. The user should take care to avoid coupling stray signals and ground errors into the control pin, which will directly affect the performance of the device. As shown in the application examples, a 1  $\mu F$  capacitor is recommended, located near the pin. Noisy environments may require that this value be increased to 10  $\mu F$ .

Due to temperature effects on the gain core transistors, the control port has a -2700 ppm/ $^{\circ}C$  temperature coefficient which can be compensated with a single +2700 ppm/ $^{\circ}C$  tempistor (RCD Components, Inc., Manchester, NH, (605) 669-0054) in the control voltage divider chain.

### COMPENSATION

In the VCA configuration, the SSM-2018 utilizes a unique adaptive compensation network to maximize the internal closed-loop gain of the device independent of overall system gain. As shown in the application circuits, a compensation capacitor is connected between Pins 5 and 8, and Pin 9 is unconnected. In VCP circuits, the feedback of the system is constant with gain and the adaptive circuit is defeated by connecting Pin 9 to ground. In circuits requiring moderate gain, the value of the compensation capacitor can be reduced in order to obtain wider signal bandwidth.

### OUTPUT SECTION

The SSM-2018 has two voltage outputs, and three current outputs which can deliver a minimum of 750  $\mu A$  when operating from  $\pm 15$  V supplies. Feedback resistors for the internal or external op amps which convert the currents to a desired voltage should be greater than 17 k $\Omega$  with  $\pm 15$  V supplies. As shown in the functional diagram, the current outputs are virtual grounds in normal operation. Amplifiers A1 and A2 act as current mirrors which maintain the  $+I_{1-G}$  potential to ground. A3 and A4 are current-to-voltage converters which keep the outputs  $-I_G$  and  $-I_{1-G}$  at ground potential, with current outputs capable of sinking greater than 10 mA and sourcing a minimum of 1.65 mA.

### TRIMMING THE SSM-2018

The network recommended for correcting waveform symmetry and trimming offset is shown in Figure 11. Both trims affect offset and control feedthrough. The symmetry trim also controls distortion performance and is mandatory for Class AB operation, but may not be necessary in less critical applications operating in Class A. The offset trim is appropriate in those situations requiring improved control feedthrough.

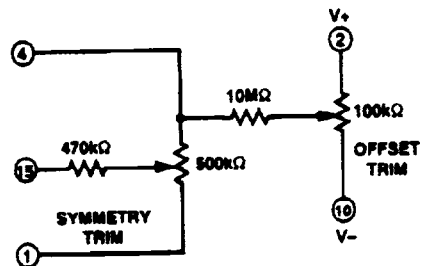

Figure 11. Symmetry and Offset Trim Network

**TRIM PROCEDURE**

**Symmetry Trim**

If the symmetry trim is to be performed, it should precede the offset adjustment.

1. Apply a 1 kHz sine wave of +10 dBV to the input, with the control voltage set at unity gain.
2. Adjust the symmetry trim potentiometer to minimize distortion of the output signal.

**Offset Trim**

The offset trim corrects for control feedthrough error.

1. Ground the input signal and apply a 60 Hz sine wave to the control port. The sine wave should have its high and low peaks correspond to the highest gain to be used in the application and 30 dB attenuation, respectively. For example, a range of +20 dB maximum gain and 30 dB attenuation requires that a sine wave swinging between -560 mV and +840 mV be applied to Pin 11.
2. Adjust the offset trim potentiometer to null the control feedthrough seen at the output.

The incorporation of dc blocking capacitors at the inputs will prevent offsets from previous stages from affecting the performance of the SSM-2018. Many applications, such as panning and equalizer circuits, will not require the offset trim. The con-

trol settings for these circuits are usually established at setup and changed infrequently. Audible control feedthrough can be suppressed by inserting a time constant of 10-20 ms in the control signal path.

**APPLICATIONS INFORMATION**

Circuits which illustrate four basic applications of the SSM-2018 are included below, accompanied by graphs demonstrating the observed performance. Armed with a basic understanding of the OVCE structure, the user can easily modify these circuits for his particular needs and realize additional functions such as voltage-controlled preamplifiers, compressors/limiters, and many other functions. Data taken on the Audio Precision System One utilizes the internal 80 kHz noise filter.

**THE BASIC OVCE**

The basic configuration for the OVCE with differential inputs discussed in Figure 7 is demonstrated in Figure 12, which includes the recommended offset and symmetry trim circuitry. Note that the feedback for the output amplifiers includes a minimum 5 pF capacitor for high frequency cutoff and noise limiting, and that the 1:4 control voltage divider is accompanied by 1 μF, to avoid control errors due to noise. The observed performance of this circuit is illustrated in Figures 13 through 17

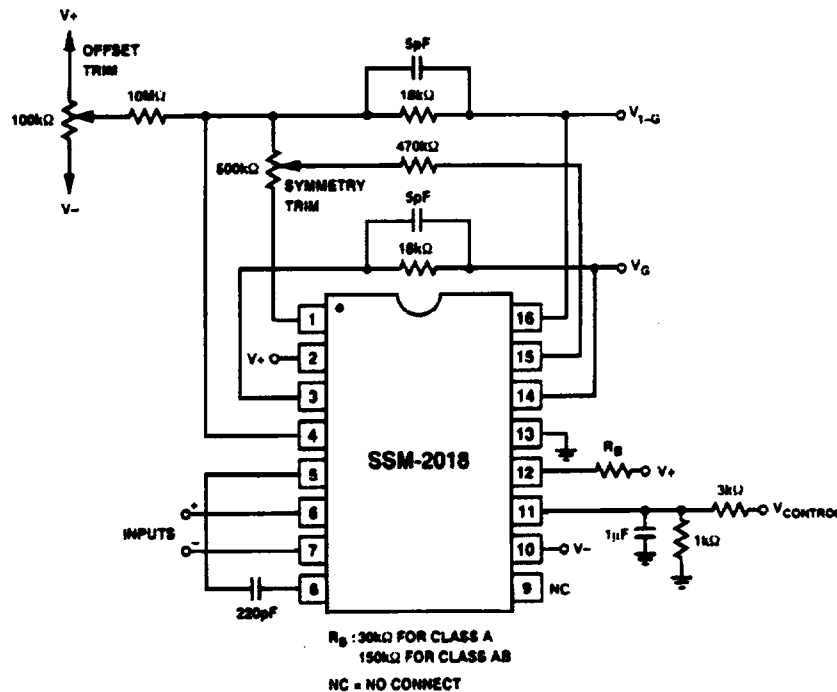

Figure 12. OVCE Application Circuit

# SSM-2018

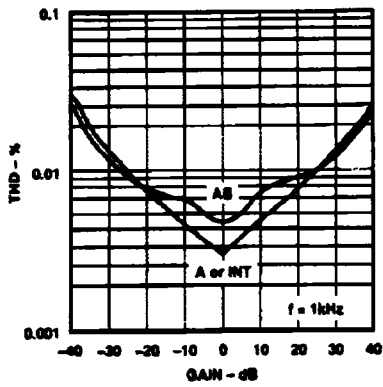

Figure 13. OVCE THD vs. Gain

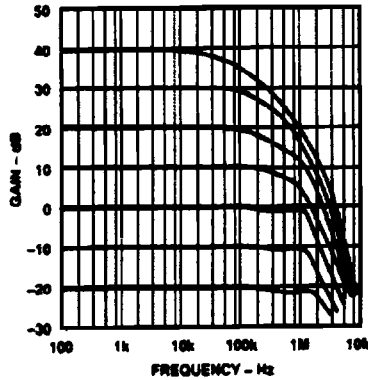

Figure 14. OVCE Bandwidth vs. Gain

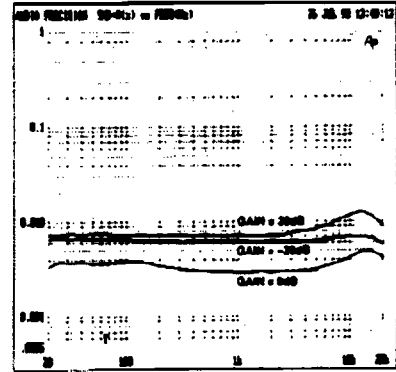

Figure 15. OVCE THD+N vs. Frequency, Class A Operation

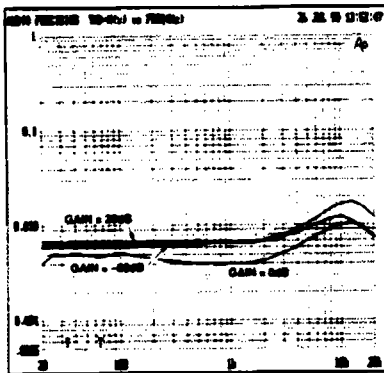

Figure 16. OVCE THD+N vs. Frequency, Class AB Operation

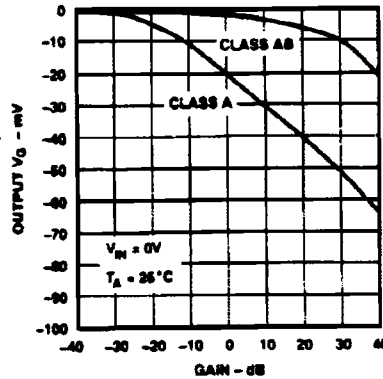

Figure 17. OVCE Output vs. Gain

## USING THE OVCE TO BUILD A SIMPLE VCA

This circuit demonstrates the flexibility of the SSM-2018 by using differential current feedback to realize a complete, minimum parts count voltage-controlled amplifier with differential or single-ended inputs. Amplifier A4 is defeated to allow current feedback to the OVCE input and enhance the frequency response and slew rate. See Figure 18. Feedback from the  $+I_{1-G}$  output to the inverting input and from  $-I_{1-G}$  to the non-inverting input creates differential virtual ground inputs. Single-ended operation allows inverting or noninverting gain, with the unused input unconnected. The output from amplifier A3 is available at Pin 14. A capacitor of any value can be connected across buffer A3 (Pin 3 to Pin 14) to band-limit the output signal as desired. Refer to Figures 19 through 21 for the typical performance obtained with this implementation.

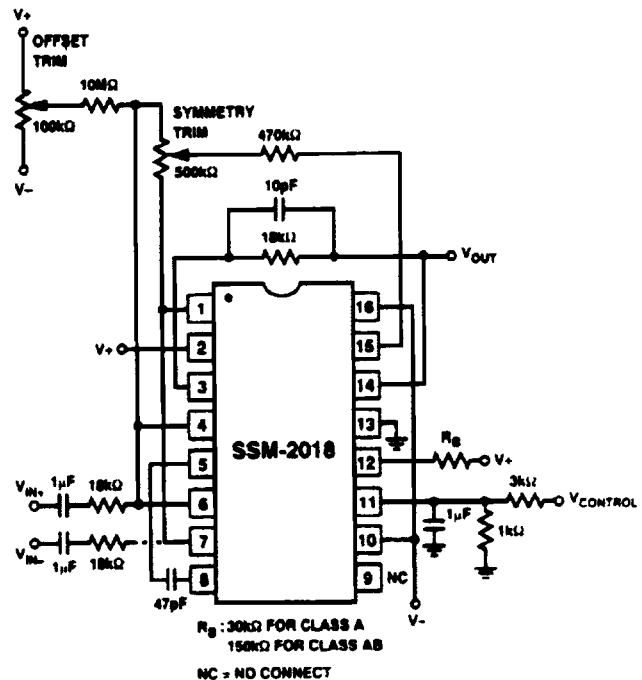

Figure 18. Simple VCA Application Circuit



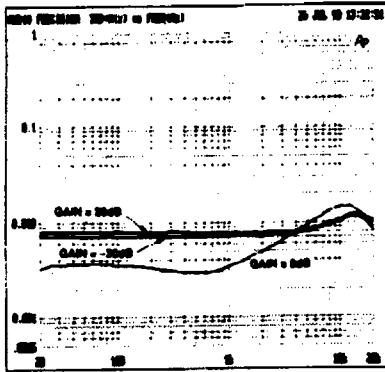

Figure 19. VCA THD+N vs. Frequency, Class A Operation

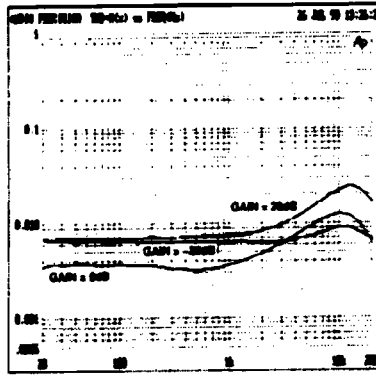

Figure 20. VCA THD+N vs. Frequency, Class AB Operation

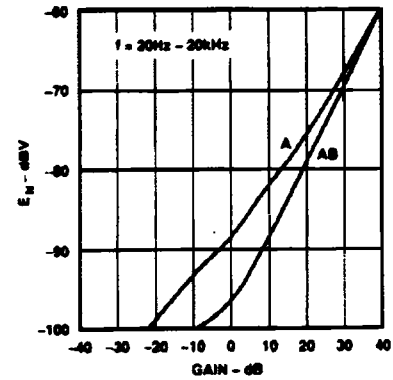

Figure 21. VCA/OVCE Noise vs. Gain

**A VOLTAGE-CONTROLLED PANNER**

The ratiometric outputs of the SSM-2018 allow the user to realize an excellent potentiometer with minimal external components, as shown in Figure 22. As first shown in Figure 10, the outputs are summed and fed back to the noninverting input to perform the basic panning function. Figures 23 through 29 demonstrate the performance observed with this configuration.

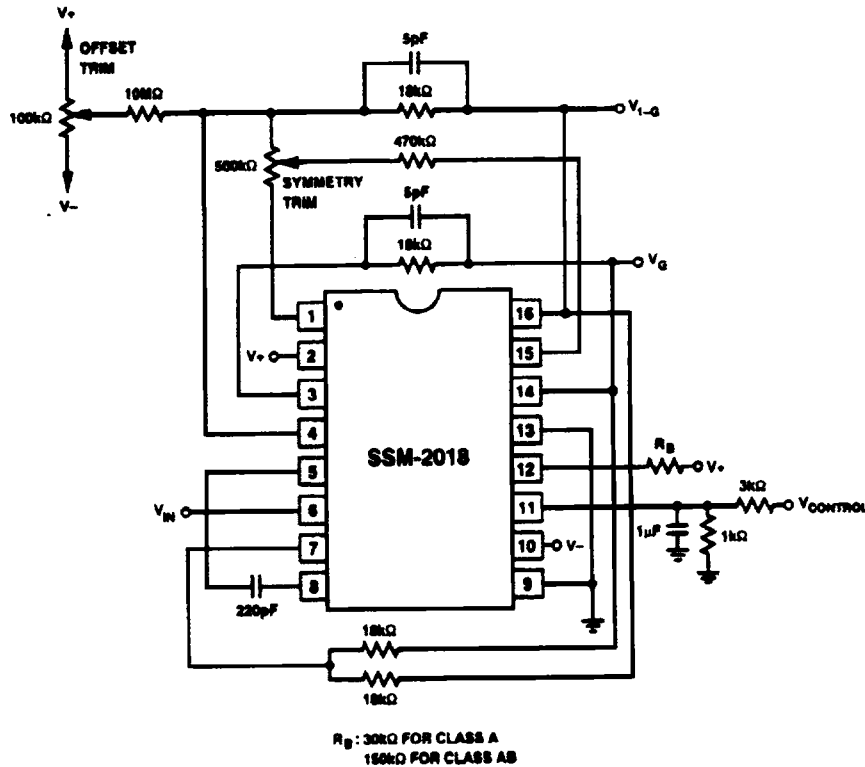

Figure 22. VCP Application Circuit

# SSM-2018

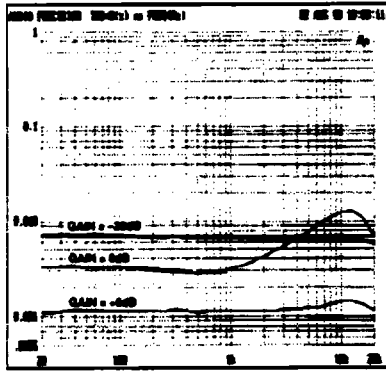

Figure 23. VCP THD+N vs. Frequency, Class A Operation

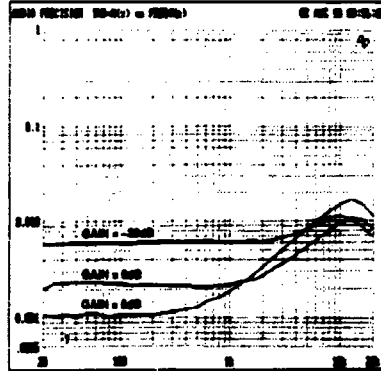

Figure 24. VCP THD+N vs. Frequency, Class AB Operation

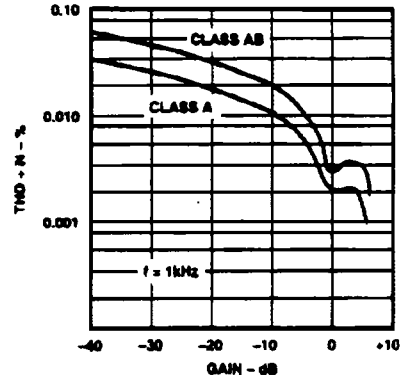

Figure 25. VCP THD+N vs. Gain

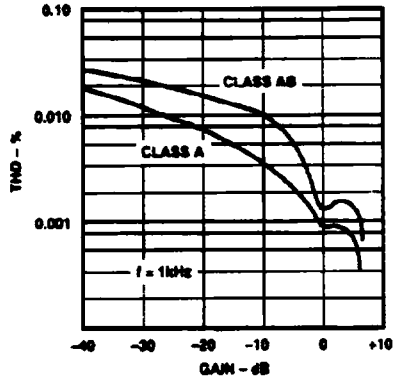

Figure 26. VCP THD vs. Gain

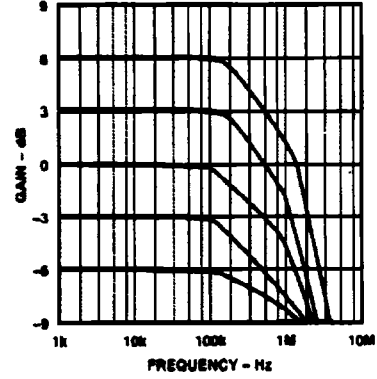

Figure 27. VCP Bandwidth vs. Gain, Class A Operation

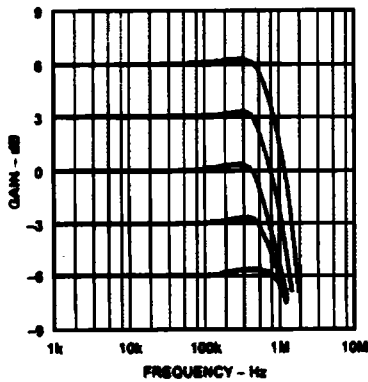

Figure 28. VCP Bandwidth vs. Gain, Class AB Operation

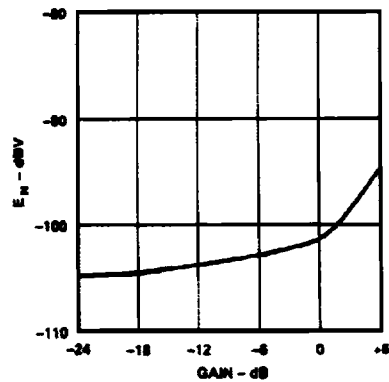

Figure 29. VCP Noise vs. Gain, Class AB Operation

**A HIGH QUALITY VOLTAGE-CONTROLLED EQUALIZER USING THE SSM-2018**

Figure 30 shows the SSM-2018 in the VCEQ configuration, utilizing a simple RC high pass filter network to generate a basic reciprocal high frequency equalizer with excellent noise and distortion characteristics. The noise and gain performance obtained with this circuit is shown in Figures 31 through 34. The user is free to replace the filter network in order to obtain the desired gain characteristics. Any other noninverting filter, including low-pass or bandpass functions, will yield a voltage-controlled equalizer with the form of the filter transfer function. The addition of voltage control to the equalization function creates an extremely attractive alternative.

**UPGRADING SSM-2014 SOCKETS WITH THE SSM-2018**

The SSM-2018 is a drop-in replacement for the SSM-2014, offering noticeable performance improvements with minor changes in the original circuitry. The SSM-2014 requires external compensation to assure optimal performance, including RC networks on Pins 1, 3, and 4, and a capacitor on Pin 9. These components are not necessary when using the SSM-2018, and should be removed in order to realize the full performance of the device. For best results, the SSM-2018 should not be evaluated in an SSM-2014 evaluation board. An SSM-2018 evaluation board is available through your local sales office.

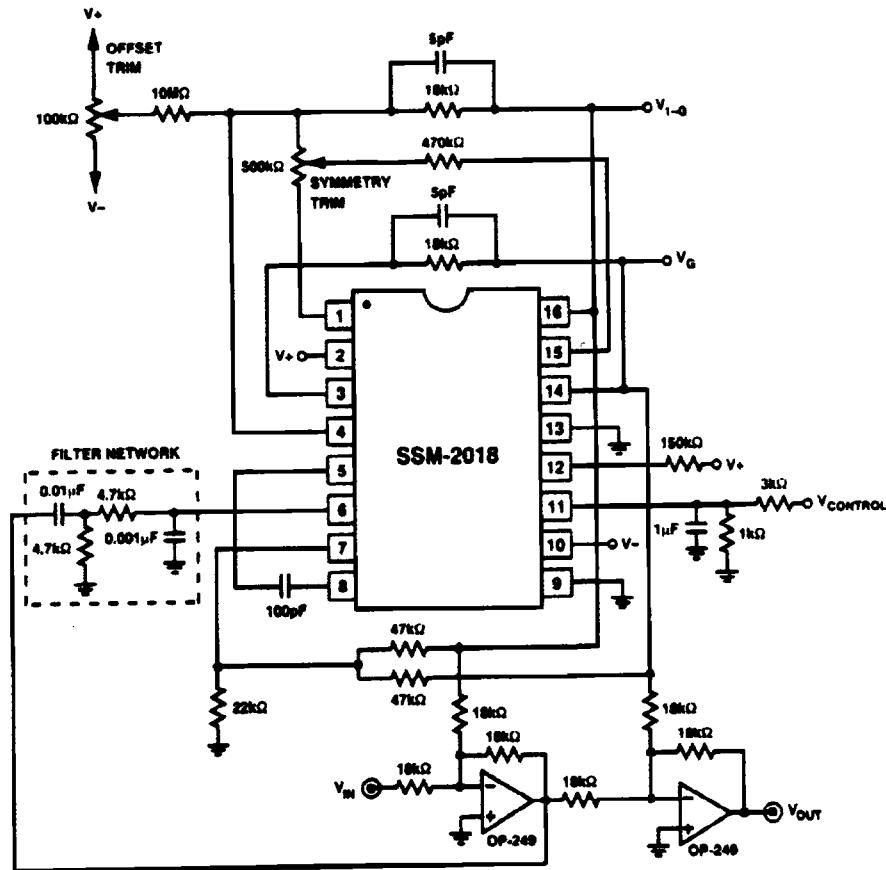

Figure 30. Voltage Controlled Equalizer Application Circuit

# SSM-2018

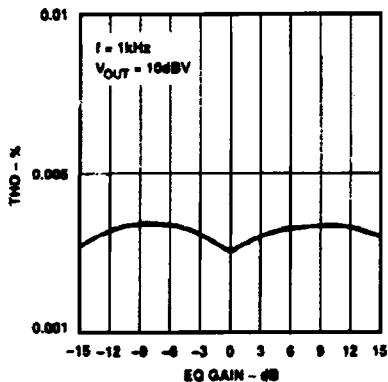

Figure 31. Equalizer THD+N vs. Gain

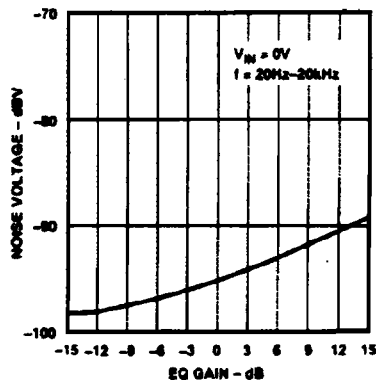

Figure 32. Equalizer Noise vs. Gain

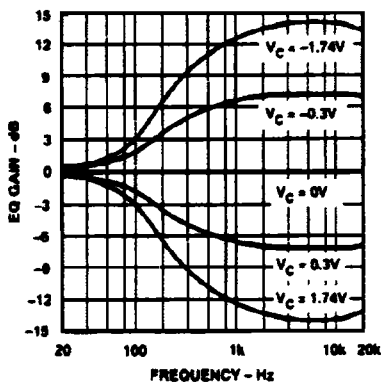

Figure 33. Equalizer Frequency Response vs. Gain

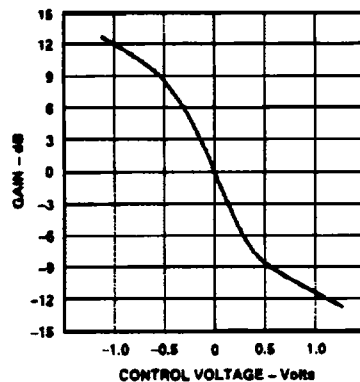

Figure 34. Equalizer Gain vs. Control Voltage

## ORDERING INFORMATION

Model	Operating Temperature Range	Package
SSM-2018P	XIND*	16-Pin Plastic
SSM-2018S	XIND	16-Pin SOIC

\*XIND = -40°C to +85°C

## OUTLINE DIMENSIONS

Dimensions shown in inches and (mm)

### 16-Pin SOIC

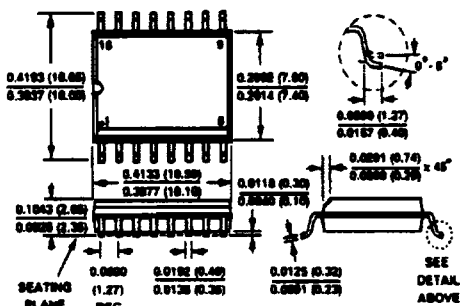

### 16-Pin Plastic

