

300 mW Dual Surface Mount Zener Diodes

Features

- SOT–23 surface mount package
- 300 mW power dissipation rating
- Ideally suited for automatic insertion
- ΔV_Z for both diodes in one case is $\leq 5\%$
- Common cathode style available see DZ series

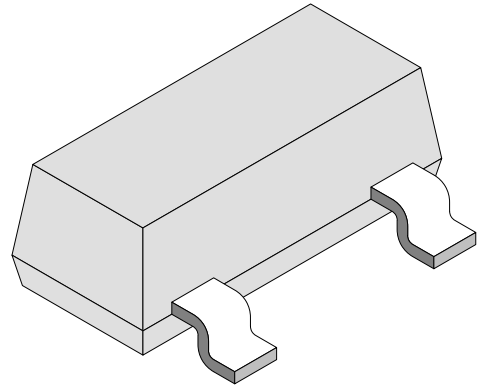

94 8550

Order Instruction

Type	Ordering Code	Remarks
AZ23C2V7	AZ23C2V7–GS08	Tape and Reel

Absolute Maximum Ratings

 $T_j = 25^\circ\text{C}$

Parameter	Test Conditions	Type	Symbol	Value	Unit
Power dissipation	on fiberglass substrate		P_d	300	mW
Junction and storage temperature range			$T_j = T_{stg}$	-55...+150	$^\circ\text{C}$

Maximum Thermal Resistance

 $T_j = 25^\circ\text{C}$

Parameter	Test Conditions	Symbol	Value	Unit
Junction ambient	on fiberglass substrate	R_{thJA}	420	K/W

Type	Marking	V_Z	Z_{ZT}	Z_{ZK}	T_C	V_R
AZ23C...		V	Ω	Ω	%/°C	V
		@ $I_{ZT}=5\text{mA}$	@ $I_{ZT}=5\text{mA}$	@ $I_{ZT}=1\text{mA}$		@ $I_R=0.1\mu\text{A}$
2V7	KD1	2.5 to 2.9	83	500	-0.065	–
3V0	KD2	2.8 to 3.2	95	500	-0.060	–
3V3	KD3	3.1 to 3.5	95	500	-0.055	–
3V6	KD4	3.4 to 3.8	95	500	-0.055	–
3V9	KD5	3.7 to 4.1	95	500	-0.050	–
4V3	KD6	4.0 to 4.6	95	500	-0.035	–
4V7	KD7	4.4 to 5.0	78	500	-0.015	–
5V1	KD8	4.8 to 5.4	60	480	+0.005	0.8
5V6	KD9	5.2 to 6.0	40	400	+0.020	1.0
6V2	KDA	5.8 to 6.6	10	200	+0.030	2.0
6V8	KDB	6.4 to 7.2	8	150	+0.045	3.0
7V5	KDC	7.0 to 7.9	7	50	+0.050	5.0
8V2	KDD	7.7 to 8.7	7	50	+0.055	6.0
9V1	KDE	8.5 to 9.6	10	50	+0.065	7.0
10	KDF	9.4 to 10.6	15	70	+0.065	7.5
11	KDG	10.4 to 11.6	20	70	+0.070	8.5
12	KDH	11.4 to 12.7	20	90	+0.075	9.0
13	KDI	12.4 to 14.1	25	110	+0.080	10.0
15	KDJ	13.8 to 15.6	30	110	+0.080	11.0
16	KDK	15.3 to 17.1	40	170	+0.090	12.0
18	KDL	16.8 to 19.1	50	170	+0.090	14.0
20	KDM	18.8 to 21.2	50	220	+0.090	15.0
22	KDN	20.8 to 23.3	55	220	+0.090	17.0
24	KDO	22.8 to 25.6	80	220	+0.090	18.0
27	KDP	25.1 to 28.9	80	250	+0.090	20.0
30	KDQ	28 to 32	80	250	+0.090	22.5
33	KDR	31 to 35	80	250	+0.090	25.0
36	KDS	34 to 38	90	250	+0.090	27.0
39	KDT	37 to 41	90	300	+0.110	29.0
43	KDU	40 to 46	100	700	+0.110	32.0
47	KDV	44 to 50	100	750	+0.110	35.0
51	KDW	48 to 54	100	750	+0.110	38.0

- 1) Device on fiberglass substrate
- 2) Tested with I_{ZT} current pulses. Pulse width = 5 ms.

Dimensions in mm

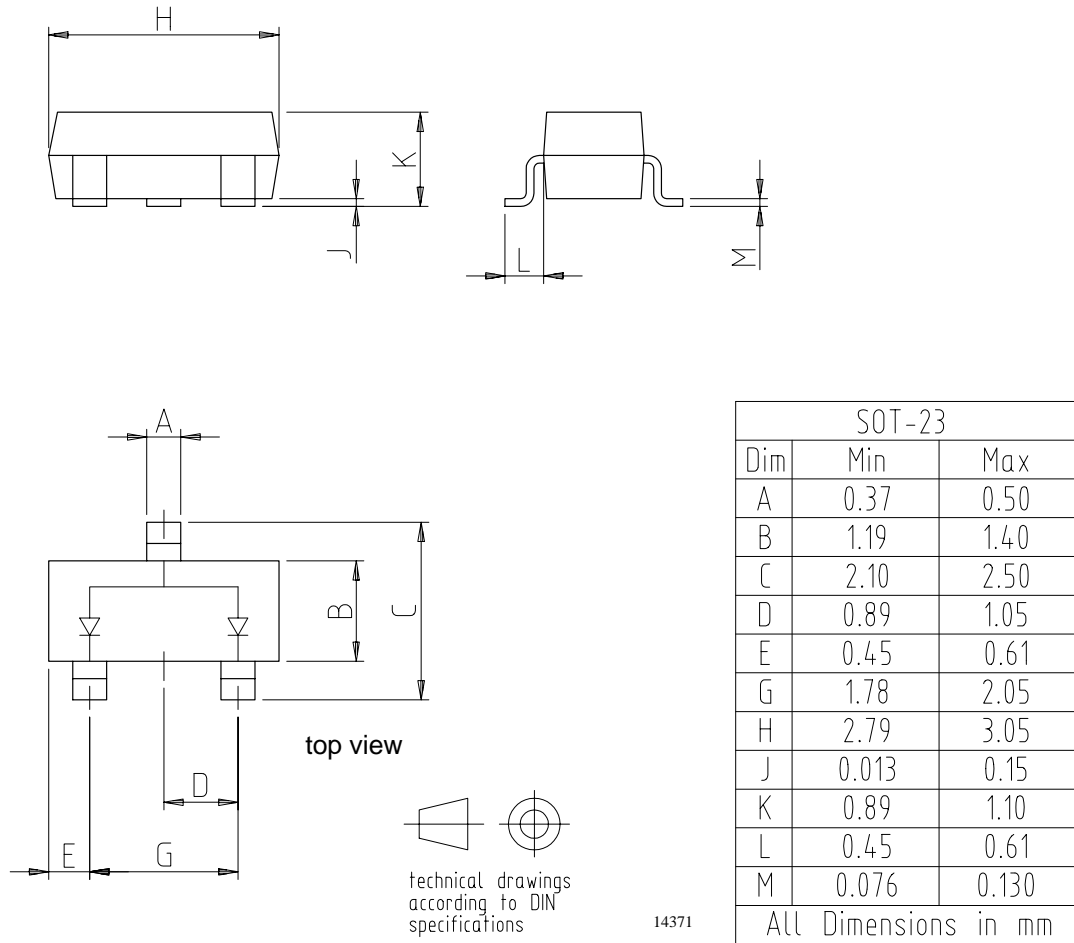

Case: SOT23, molded plastic
 Mounting position: any
 Approx. weight: 0.008 grams

Ozone Depleting Substances Policy Statement

It is the policy of **Vishay Semiconductor GmbH** to

1. Meet all present and future national and international statutory requirements.
2. Regularly and continuously improve the performance of our products, processes, distribution and operating systems
with respect to their impact on the health and safety of our employees and the public, as well as their impact on the environment.

It is particular concern to control or eliminate releases of those substances into the atmosphere which are known as ozone depleting substances (ODSs).

The Montreal Protocol (1987) and its London Amendments (1990) intend to severely restrict the use of ODSs and forbid their use within the next ten years. Various national and international initiatives are pressing for an earlier ban on these substances.

Vishay Semiconductor GmbH has been able to use its policy of continuous improvements to eliminate the use of ODSs listed in the following documents.

1. Annex A, B and list of transitional substances of the Montreal Protocol and the London Amendments respectively
2. Class I and II ozone depleting substances in the Clean Air Act Amendments of 1990 by the Environmental Protection Agency (EPA) in the USA
3. Council Decision 88/540/EEC and 91/690/EEC Annex A, B and C (transitional substances) respectively.

Vishay Semiconductor GmbH can certify that our semiconductors are not manufactured with ozone depleting substances and do not contain such substances.

We reserve the right to make changes to improve technical design and may do so without further notice.

Parameters can vary in different applications. All operating parameters must be validated for each customer application by the customer. Should the buyer use Vishay-Telefunken products for any unintended or unauthorized application, the buyer shall indemnify Vishay-Telefunken against all claims, costs, damages, and expenses, arising out of, directly or indirectly, any claim of personal damage, injury or death associated with such unintended or unauthorized use.

Vishay Semiconductor GmbH, P.O.B. 3535, D-74025 Heilbronn, Germany
Telephone: 49 (0) 7131 67 2831, Fax number: 49 (0) 7131 67 2423