

**3-TERMINAL ADJUSTABLE REGULATOR****AZ317L****General Description**

The AZ317L is an adjustable 3-terminal positive voltage regulator capable of supplying 100mA over a 1.2V to 12V output range. This voltage regulator is exceptionally easy to use and requires only two external resistors to set the output voltage. Both line and load regulation are better than standard fixed regulators.

In addition to higher performance than fixed regulators, AZ317L employs overload protection. Included on the chip are current limiting and thermal overload protection. All overload protection circuitry remains fully functional even when the adjustment terminal is disconnected.

The AZ317L is available in standard TO-92 and SOIC-8 packages.

Features

- Adjustable Output Down to 1.2V
- Guaranteed 100mA Output Current
- Output Short Circuit Protected
- Line Regulation: 0.01%/V
- Load Regulation: 0.1%
- Constant Current Limit over Temperature
- Standard 3-lead Transistor Package
- Input Ripple Rejection: 70dB

Applications

- High Efficiency Linear Regulators
- Post Regulation for Switching Supplies
- Microprocessor Power Supply
- Mother Board I/O Power Supply

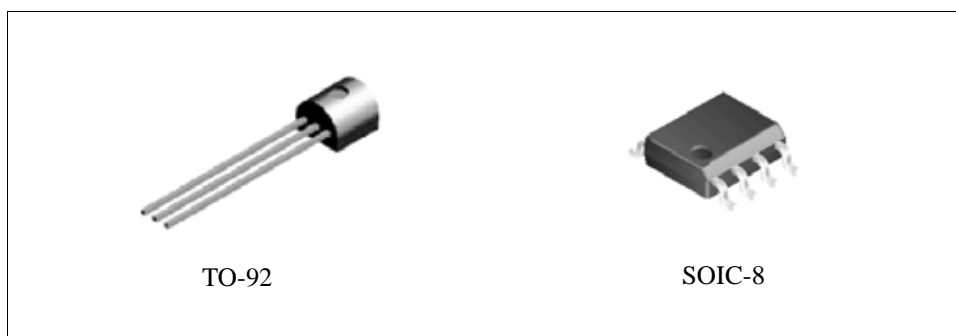

Figure 1. Package Types of AZ317L



3-TERMINAL ADJUSTABLE REGULATOR

AZ317L

Pin Configuration

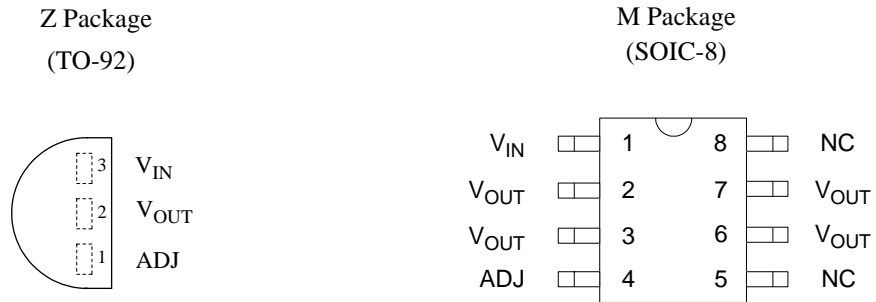

Figure 2. Pin Configuration of AZ317L (Top View)

Functional Block Diagram

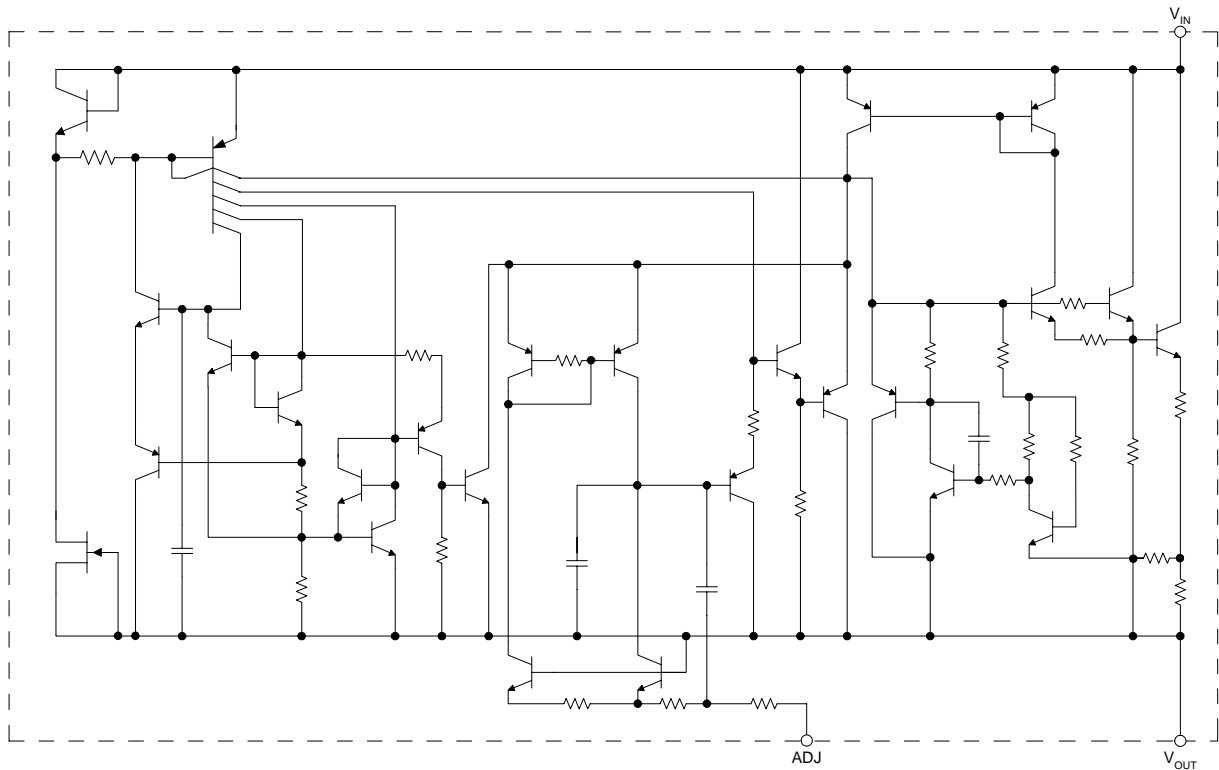

Figure 3. Functional Block Diagram of AZ317L



3-TERMINAL ADJUSTABLE REGULATOR

AZ317L

Ordering Information

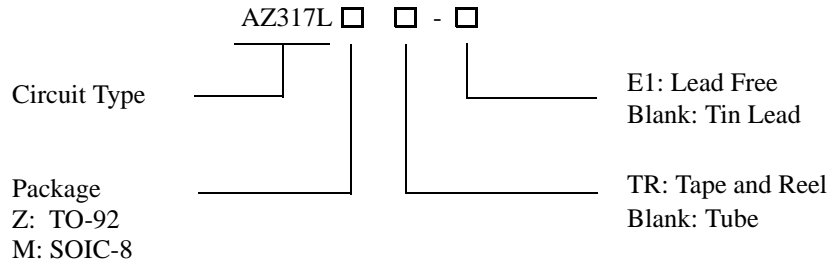

Package	Temperature Range	Part Number		Marking ID		Packing Type
		Tin Lead	Lead Free	Tin Lead	Lead Free	
TO-92	0 to 125°C	AZ317LZ	AZ317LZ-E1	AZ317LZ	AZ317LZ-E1	Tube
		AZ317LZTR	AZ317LZTR-E1	AZ317LZ	AZ317LZ-E1	Tape & Reel
SOIC-8	0 to 125°C	AZ317LM	AZ317LM-E1	317LM	317LM-E1	Tube
		AZ317LMTR	AZ317LMTR-E1	317LM	317LM-E1	Tape & Reel

BCD Semiconductor's Pb-free products, as designated with "E1" suffix in the part number, are RoHS compliant.

**3-TERMINAL ADJUSTABLE REGULATOR****AZ317L****Absolute Maximum Ratings (Note 1)**

Parameter	Symbol	Value	Unit
Input Voltage	V_{IN}	20	V
Input-Output Voltage Differential		15	V
Operating Junction Temperature	T_J	150	°C
Storage Temperature Range	T_{STG}	-65 to 150	°C
Power Dissipation	P_D	700	mW
Lead Temperature (Soldering, 4sec.)	T_{LEAD}	260	°C
ESD (Human Body Model)	ESD	2000	V
ESD (Machine Model)	ESD	200	V

Note 1: Stresses greater than those listed under "Absolute Maximum Ratings" may cause permanent damage to the device. These are stress ratings only, and functional operation of the device at these or any other conditions beyond those indicated under "Recommended Operating Conditions" is not implied. Exposure to "Absolute Maximum Ratings" for extended periods may affect device reliability.

Recommended Operating Conditions

Parameter	Symbol	Min	Max	Unit
Input Voltage	V_{IN}		18	V
Operating Junction Temperature	T_J	0	125	°C

**3-TERMINAL ADJUSTABLE REGULATOR****AZ317L****Electrical Characteristics**

$0^{\circ}\text{C} \leq T_J \leq 125^{\circ}\text{C}$, $V_{\text{IN}} - V_{\text{OUT}} = 5\text{V}$, $I_{\text{OUT}} = 40\text{mA}$, $P_D \leq 625\text{mW}$, unless otherwise specified.

Parameter	Symbol	Conditions	Min	Typ	Max	Unit
Line Regulation	ΔV_{OUT}	$T_J = 25^{\circ}\text{C}$, $3\text{V} \leq (V_{\text{IN}} - V_{\text{OUT}}) \leq 15\text{V}$ $I_{\text{OUT}} \leq 20\text{mA}$ (Note 2)		0.01	0.04	%/V
		$3\text{V} \leq (V_{\text{IN}} - V_{\text{OUT}}) \leq 15\text{V}$, $I_{\text{OUT}} \leq 20\text{mA}$ (Note 2)		0.02	0.07	%/V
Load Regulation	ΔV_{OUT}	$T_J = 25^{\circ}\text{C}$, $5\text{mA} \leq I_{\text{OUT}} \leq 100\text{mA}$ (Note 2)		0.1	0.5	%
		$5\text{mA} \leq I_{\text{OUT}} \leq 100\text{mA}$ (Note 2)		0.3	1.5	%
Thermal Regulation		$T_J = 25^{\circ}\text{C}$, 10ms Pulse		0.04	0.2	%/W
Adjust Pin Current	I_{ADJ}			50	100	μA
Adjust Pin Current Change	ΔI_{ADJ}	$5\text{mA} \leq I_{\text{OUT}} \leq 100\text{mA}$ $3\text{V} \leq (V_{\text{IN}} - V_{\text{OUT}}) \leq 15\text{V}$		0.2	5	μA
Reference Voltage	V_{REF}	$3\text{V} \leq (V_{\text{IN}} - V_{\text{OUT}}) \leq 15\text{V}$ $5\text{mA} \leq I_{\text{OUT}} \leq 100\text{mA}$	1.20	1.25	1.30	V
Current Limit	I_{LIMIT}	$3\text{V} \leq (V_{\text{IN}} - V_{\text{OUT}}) \leq 13\text{V}$	100	200	300	mA
Minimum Load Current	$I_{\text{LOAD (MIN)}}$	$3\text{V} \leq (V_{\text{IN}} - V_{\text{OUT}}) \leq 13\text{V}$		3.5	5	mA
Ripple Rejection	PSRR	$V_{\text{OUT}} = 10\text{V}$, $f = 120\text{Hz}$, $C_{\text{ADJ}} = 0\mu\text{F}$		62		dB
		$V_{\text{OUT}} = 10\text{V}$, $f = 120\text{Hz}$, $C_{\text{ADJ}} = 10\mu\text{F}$	60	70		
Temperature Stability		$0^{\circ}\text{C} \leq T_J \leq 125^{\circ}\text{C}$		0.65		%
Long Term Stability		$T_J = 125^{\circ}\text{C}$, 1000 Hours		0.3	1	%
RMS Output Noise (% of V_{OUT})		$T_J = 25^{\circ}\text{C}$, $10\text{Hz} \leq f \leq 10\text{KHz}$		0.003		%
Thermal Resistance Junction to Case		TO-92		185		$^{\circ}\text{C/W}$
		SOIC-8		175		

Note 2: Regulation is measured at constant junction temperature, using pulse testing with a low duty cycle. Changes in output voltage due to heating effects are covered under the specification of thermal regulation.



3-TERMINAL ADJUSTABLE REGULATOR

AZ317L

Typical Performance Characteristics

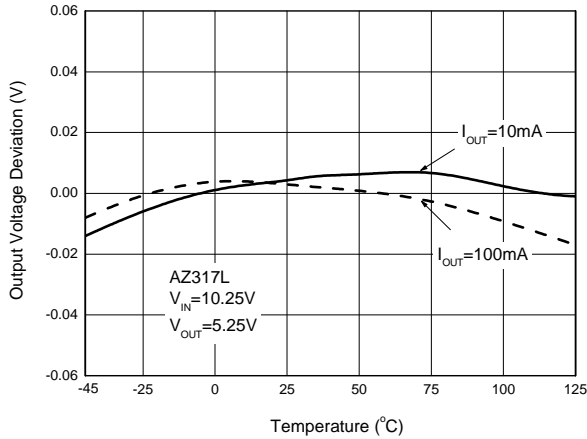

Figure 4. Load Regulation vs. Temperature

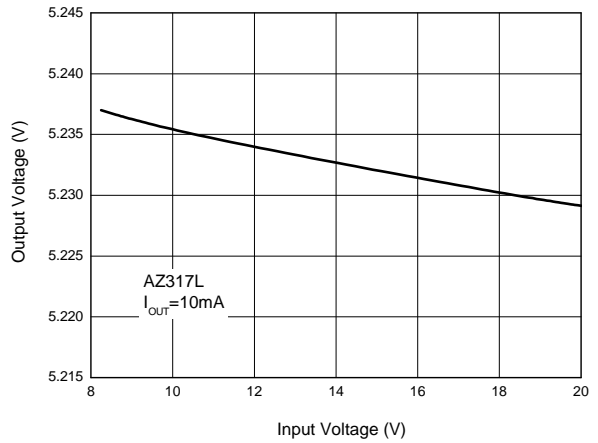

Figure 5. Output Voltage vs. Input Voltage

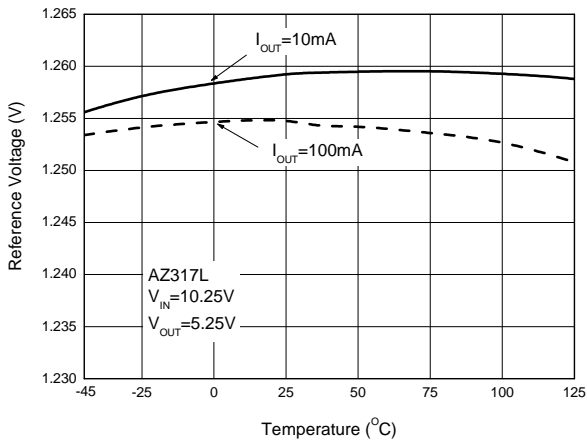

Figure 6. Reference Voltage vs. Temperature

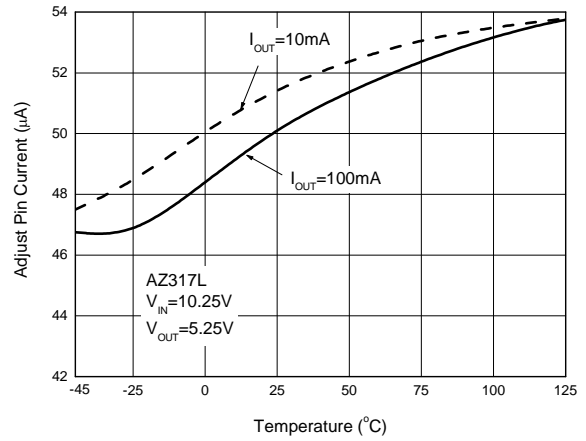

Figure 7. Adjust Pin Current vs. Temperature



3-TERMINAL ADJUSTABLE REGULATOR

AZ317L

Typical Performance Characteristics (Continued)

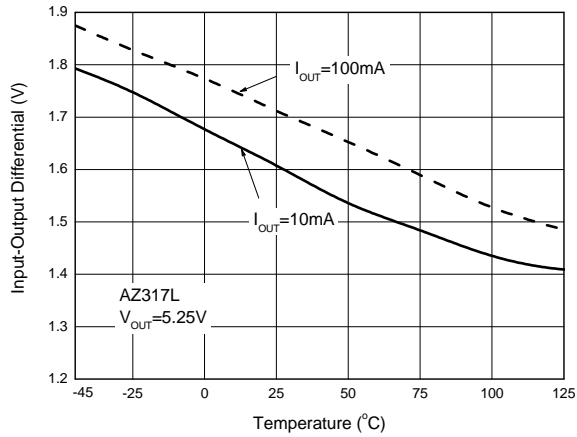

Figure 8. Dropout Voltage vs. Temperature

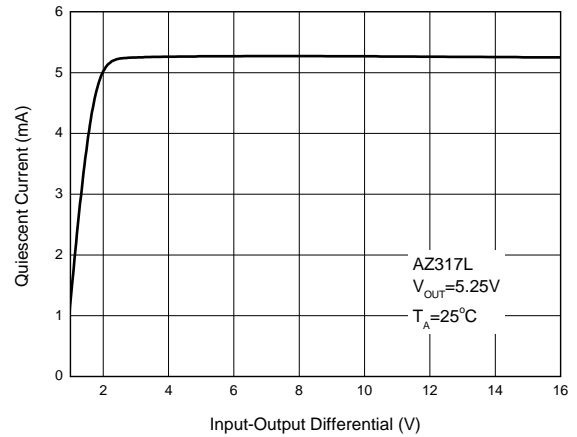

Figure 9. Minimum Operating Current

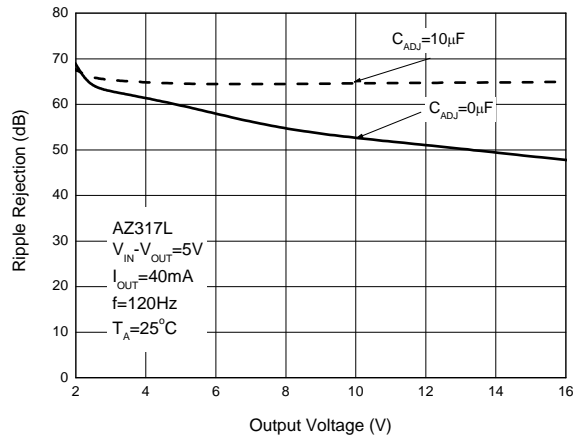

Figure 10. Ripple Rejection vs. Output Voltage

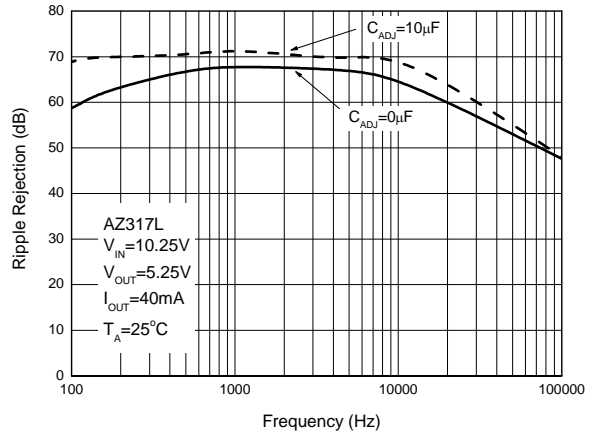

Figure 11. Ripple Rejection vs. Frequency



3-TERMINAL ADJUSTABLE REGULATOR

AZ317L

Typical Performance Characteristics (Continued)

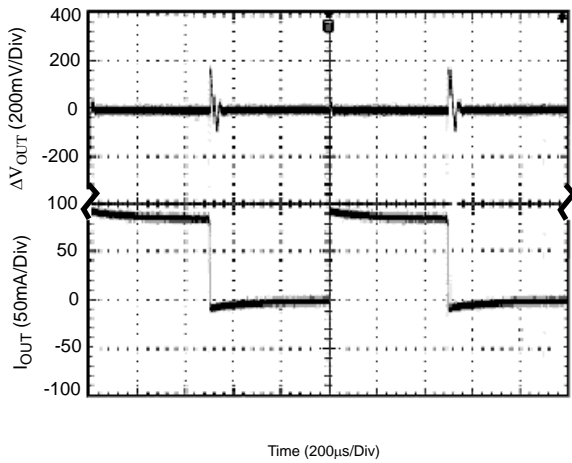

Figure 12. Load Transient Response
(Conditions: $V_{IN}=10.25V$, $V_{OUT}=5.25V$, $C_{IN}=0.1\mu F$,
 $C_{OUT}=1\mu F$, $T_A=25^{\circ}C$)

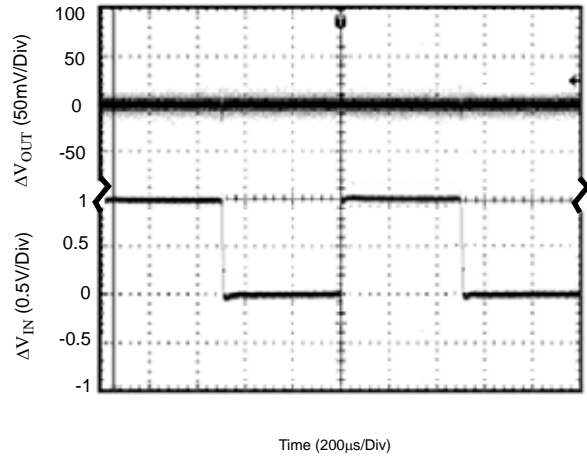

Figure 13. Line Transient Response
(Conditions: $V_{IN}=10.25$ to $11.25V$, $I_{OUT}=40mA$, $V_{OUT}=5.25V$,
 $C_{IN}=0.1\mu F$, $C_{OUT}=1\mu F$, $T_A=25^{\circ}C$)



3-TERMINAL ADJUSTABLE REGULATOR

AZ317L

Typical Application

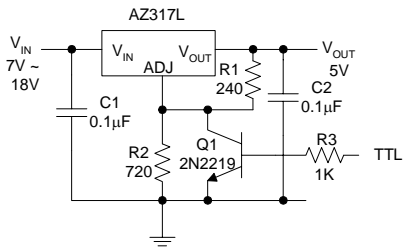

Figure 14. 5V Logic Regulator with Electronic Shutdown (Minimum output = 1.2V)

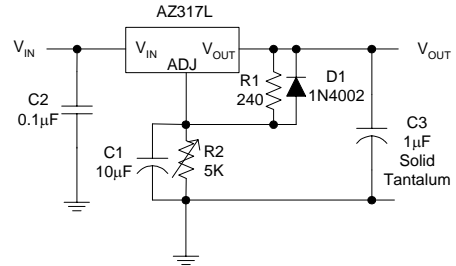

Figure 15. Adjustable Regulator with Improved Ripple Rejection
Note 5: Discharge C1 if output is shorted to ground.

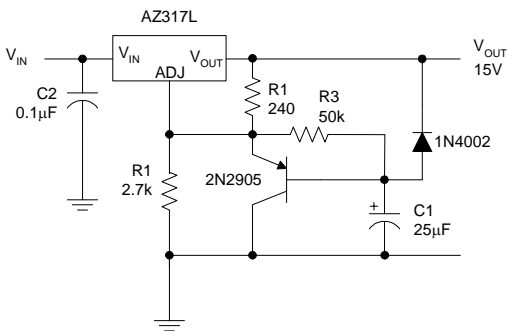

Figure 16. Slow Turn-on 15V Regulator



3-TERMINAL ADJUSTABLE REGULATOR

AZ317L

Mechanical Dimensions

TO-92

Unit: mm(inch)

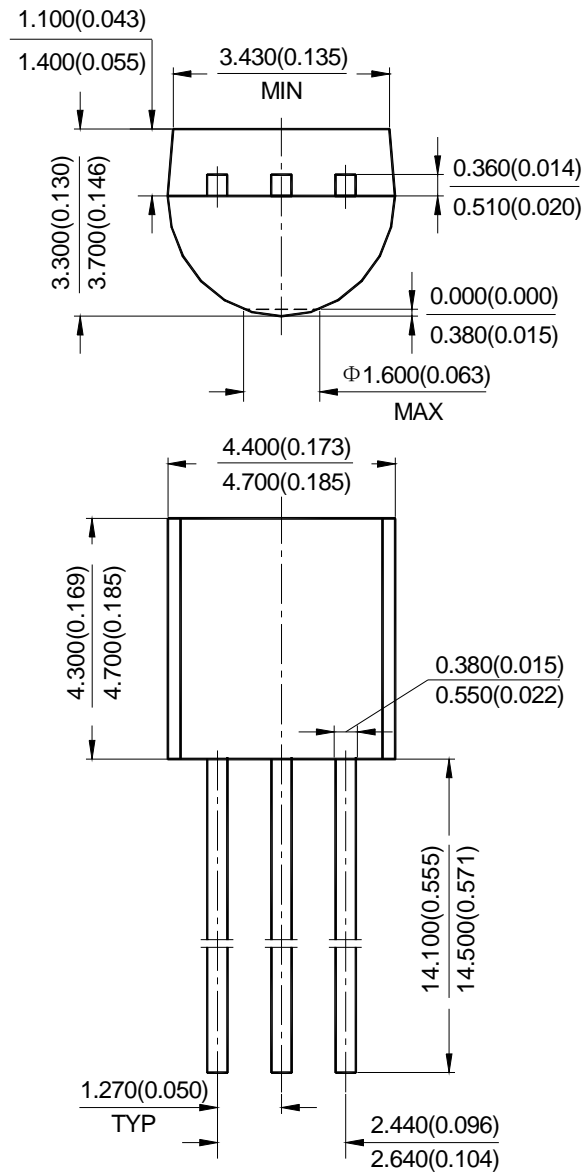



3-TERMINAL ADJUSTABLE REGULATOR

AZ317L

Mechanical Dimensions (Continued)

SOIC-8

Unit: mm(inch)

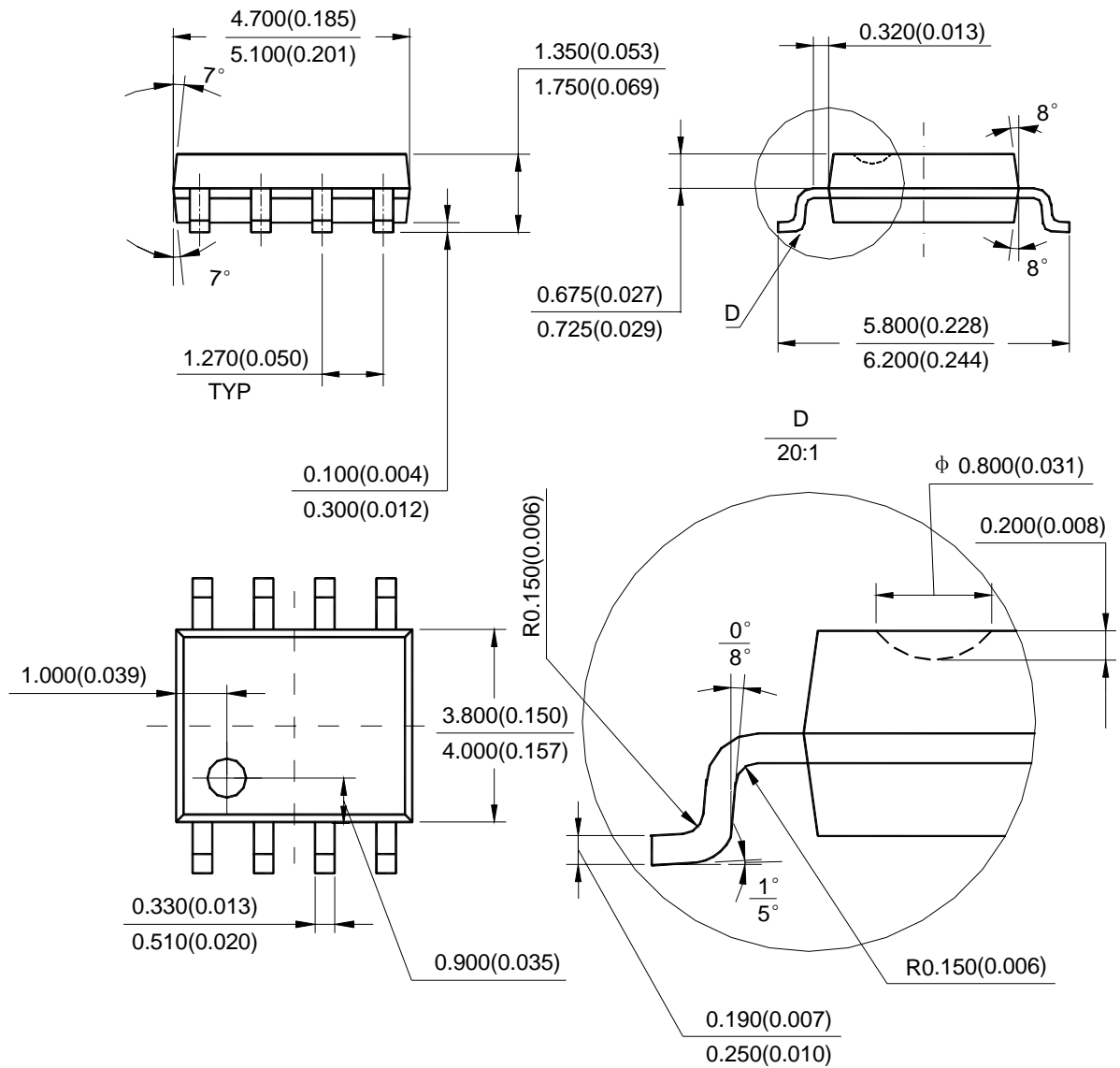



BCD Semiconductor Manufacturing Limited

<http://www.bcdsemi.com>

IMPORTANT NOTICE

BCD Semiconductor Manufacturing Limited reserves the right to make changes without further notice to any products or specifications herein. BCD Semiconductor Manufacturing Limited does not assume any responsibility for use of any its products for any particular purpose, nor does BCD Semiconductor Manufacturing Limited assume any liability arising out of the application or use of any its products or circuits. BCD Semiconductor Manufacturing Limited does not convey any license under its patent rights or other rights nor the rights of others.

MAIN SITE

BCD Semiconductor Manufacturing Limited
- Wafer Fab
Shanghai SIM-BCD Semiconductor Manufacturing Limited
800, Yi Shan Road, Shanghai 200233, China
Tel: +86-21-6485 1491, Fax: +86-21-5450 0008

BCD Semiconductor Manufacturing Limited
- IC Design Group
Advanced Analog Circuits (Shanghai) Corporation
8F, Zone B, 900, Yi Shan Road, Shanghai 200233, China
Tel: +86-21-6495 9539, Fax: +86-21-6485 9673

REGIONAL SALES OFFICE

Shenzhen Office
Shanghai SIM-BCD Semiconductor Manufacturing Co., Ltd. Shenzhen Office
Advanced Analog Circuits (Shanghai) Corporation Shenzhen Office
Room E, 5F, Noble Center, No.1006, 3rd Fuzhong Road, Futian District, Shenzhen 518026, China
Tel: +86-755-8826 7951, Fax: +86-755-8826 7865

Taiwan Office
BCD Semiconductor (Taiwan) Company Limited
4F, 298-1, Rui Guang Road, Nei-Hu District, Taipei,
Taiwan
Tel: +886-2-2656 2808, Fax: +886-2-2656 2806

USA Office
BCD Semiconductor Corporation
3170 De La Cruz Blvd., Suite 105,
Santa Clara,
CA 95054-2411, U.S.A