



Level



Pressure



Flow



Temperature



Liquid
Analysis



Registration



Systems
Components



Services



Solutions

Operating Instructions

Silopilot M FMM50

Electromechanical Level System

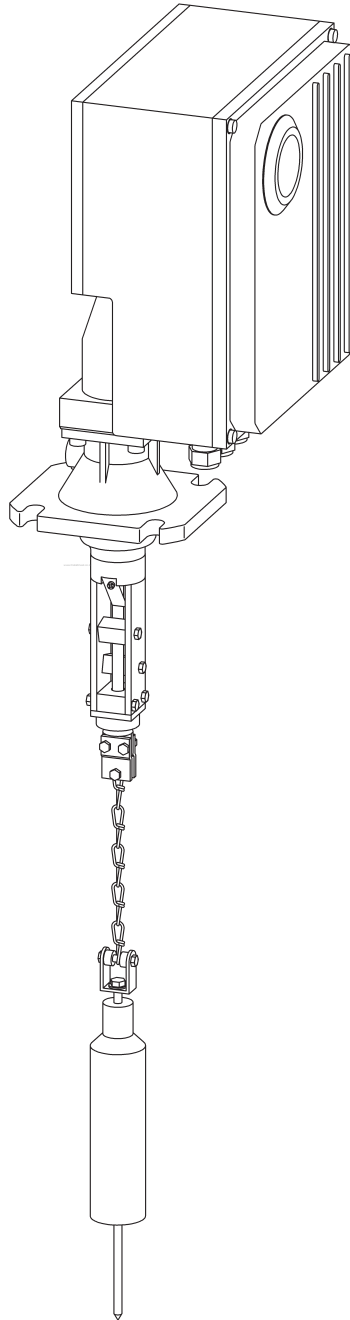

Brief overview

For easy and fast commissioning:

| | |
|---|---------------|
| Safety instructions | |
| Explanation of warning symbols Special information can be found at the corresponding point in the relevant chapter. You can see the significance from the Warning ⚠, Attention ⚡ and Note 📌 symbols. | → Page 4 ff. |
| ▼ | |
| Installation | |
| The steps for installing the device and installation conditions (such as dimensions) can be found here. | → Page 16 ff. |
| ▼ | |
| Wiring | |
| In this chapter, you can learn all about the device's electrical connections (incl. precise assignment of terminals). | → Page 26 ff. |
| ▼ | |
| Operation | |
| Here you will find an overview of the positions of the device's display and operating elements. | → Page 31 ff. |
| ▼ | |
| Commissioning | |
| Successful initial start-up is explained in this chapter. | → Page 35 ff. |
| ▼ | |
| Description of device functions | |
| All the device functions are explained in this chapter. | → Page 38 ff. |
| ▼ | |
| Troubleshooting | |
| If faults arise during operation, you can determine the causes here. Actions with which the faults can be remedied are also explained. | → Page 59 ff. |
| ▼ | |
| Index | |
| Important terms and key words for the individual chapters can be found here. Use the index to find information in a quick and targeted manner. | → Page 94 |

Table of contents

| | | | | | |
|----------|--|-----------|--------------------|--------------------------------------|-----------|
| 1 | Safety instructions | 4 | 9 | Manual mode | 57 |
| 1.1 | Intended use | 4 | 9.1 | Operation..... | 57 |
| 1.2 | Installation, commissioning, operation | 4 | 9.2 | Display..... | 58 |
| 1.3 | Safety instructions (ATEX) | 4 | 10 | Troubleshooting | 59 |
| 1.4 | Notes on safety conventions and icons | 6 | 10.1 | Error messages | 59 |
| 2 | Identification | 7 | 10.2 | Types of errors..... | 59 |
| 2.1 | Device designation | 7 | 10.3 | Error messages | 60 |
| 2.2 | Scope of delivery | 10 | 11 | Maintenance..... | 62 |
| 2.3 | Certificates and approvals | 11 | 11.1 | External cleaning | 62 |
| 3 | Sensing weights..... | 12 | 11.2 | Cleaning dirty compartment..... | 62 |
| 3.1 | Variants..... | 12 | 11.3 | Wiper check..... | 62 |
| 3.2 | Selection recommendation | 15 | 11.4 | Measuring tape check | 63 |
| 4 | Installation | 16 | 11.5 | Dirty compartment check..... | 63 |
| 4.1 | Planning the installation location | 16 | 12 | Repair..... | 64 |
| 4.2 | Installation conditions | 17 | 12.1 | Repairing Ex-certified devices..... | 64 |
| 4.3 | Installation preparation..... | 20 | 12.2 | Replacing components..... | 64 |
| 4.4 | Incoming acceptance, transport, storage..... | 21 | 12.3 | Spare parts | 69 |
| 4.5 | Installation | 22 | 12.4 | Returns | 74 |
| 4.6 | Post-installation check..... | 25 | 13 | Accessories..... | 75 |
| 5 | Wiring..... | 26 | 13.1 | Protective hood..... | 75 |
| 5.1 | Electrical connection | 26 | 14 | Technical data | 76 |
| 5.2 | Potential matching | 26 | 14.1 | Input values | 76 |
| 5.3 | Terminal assignment | 27 | 14.2 | Output values | 76 |
| 5.4 | Post-connection check | 30 | 14.3 | Accuracy..... | 76 |
| 6 | Operation | 31 | 14.4 | Activation period..... | 77 |
| 6.1 | Quick operation guide | 31 | 14.5 | Power supply | 77 |
| 6.2 | Display and operating elements | 32 | 14.6 | Environmental conditions..... | 78 |
| 6.3 | General structure of operating menu..... | 33 | 14.7 | Process conditions..... | 78 |
| 6.4 | Identification of functions | 34 | 15 | Appendix..... | 79 |
| 6.5 | Blocking / releasing operation | 34 | 15.1 | Basic settings..... | 79 |
| 7 | Commissioning..... | 35 | 15.2 | Output settings | 79 |
| 7.1 | Switching on measuring device | 35 | 15.3 | Input settings | 79 |
| 7.2 | Basic setup..... | 36 | 15.4 | Measurement parameter settings | 80 |
| 8 | Description of device functions | 38 | 15.5 | Current output settings | 80 |
| 8.1 | "Basic setup (00)" function group..... | 38 | 15.6 | Safety settings | 80 |
| 8.2 | "Inputs and outputs (01)" function group | 40 | 15.7 | Linearization settings..... | 81 |
| 8.3 | "Measurement parameters (02)" function group | 44 | 15.8 | Linearization table..... | 81 |
| 8.4 | "Current output (03)" function group..... | 48 | 15.9 | Display settings | 82 |
| 8.5 | "Safety settings (04)" function group | 49 | 15.10 | System settings..... | 82 |
| 8.6 | "Linearization (05)" function group..... | 50 | 15.11 | Explanation on contamination | 83 |
| 8.7 | "Display (06)" function group | 54 | 15.12 | Operating menu | 84 |
| 8.8 | "Diagnostics (07)" function group | 55 | 15.13 | Software history | 86 |
| 8.9 | "System parameters (08)" function group | 56 | 15.14 | EC type-examination certificate..... | 87 |
| 8.10 | "Service (0D)" function group | 56 | 15.15 | EC declaration of conformity | 92 |
| | | | Index | 94 | |

1 Safety instructions

1.1 Intended use

The Silopilot M FMM50 is a compact electromechanical level system. It is used for cyclical level measurements in bunkers or silos.

1.2 Installation, commissioning, operation

The Silopilot M FMM50 is a reliable state-of-the-art construction and complies with the relevant specifications and EC directives. However, if it is used incorrectly or not as intended, the devices may cause application-related hazardous situations, e.g. product overflow as a result of incorrect installation or setting.

Installation, electrical connection, commissioning, operation and maintenance of the measuring equipment must, therefore, only be undertaken by trained specialists who have been authorized for this purpose by the plant operator. The specialist must have read and understood these Operating Instructions and follow the instructions they contain.

Changes and repairs may only be undertaken on the device if the Operating Instructions expressly permit them.

1.3 Safety instructions (ATEX)

If the measuring system is used in explosion hazard zones, the corresponding national standards must be observed. The installation specifications, connection values and safety instructions contained in these Operating Instructions must be observed.

Please observe the following safety instructions:

- Ensure that specialists are sufficiently trained.
- The technical measurement and safety requirements of the measuring points must be observed.
- The Silopilot may only be operated when the housing is closed.
- The housing may only be opened when the supply voltage is switched off.
- The Silopilot version certified by ATEX must only be repaired by the manufacturer.
- If using the Silopilot in areas containing flammable dusts, the corresponding national standards must be observed.
- The requirements laid down in EN 50281-1-2, for example relating to dust deposits and temperatures, must be observed.
- Cable and line entries as well as dummy plugs must only be replaced with those of the same type.
- The operator must ensure that product cone discharges do not occur.

1.3.1 Features of the ATEX version

- Identification:  II 1/2D IP67 T99°C
- Certificate number: **BVS 05 ATEX E 049**





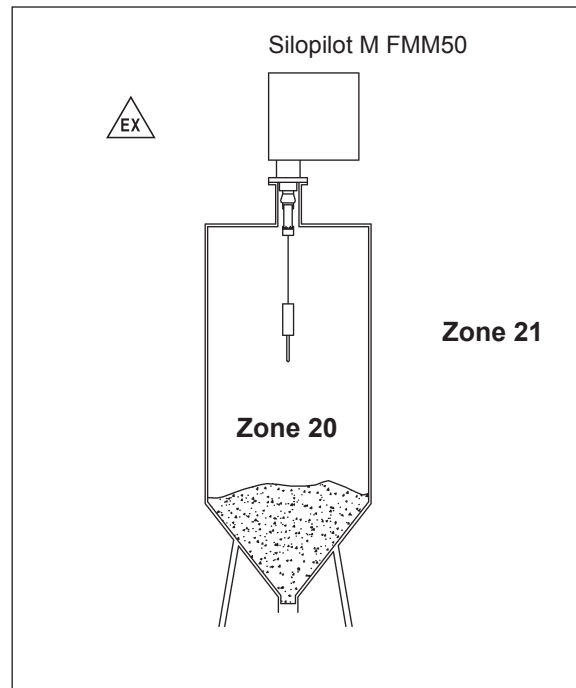







You will find a copy of the EC type-examination certificate in the Appendix 15.14.

1.3.2 Installation instructions



1.4 Notes on safety conventions and icons

In order to highlight safety-related or alternative processes, we have laid down the following safety instructions where each piece of information is identified by a corresponding pictogram.





| Safety conventions | |
|---|--|
|  | <p>Warning! A warning highlights actions or procedures which, if not performed correctly, will lead to personal injury, a safety hazard or destruction of the instrument</p> |
|  | <p>Caution! Caution highlights actions or procedures which, if not performed correctly, may lead to personal injury or incorrect functioning of the instrument</p> |
|  | <p>Note! A note highlights actions or procedures which, if not performed correctly, may indirectly affect operation or may lead to an instrument response which is not planned</p> |
| Explosion protection | |
|  | <p>Device certified for use in explosion hazardous area If the device has this symbol embossed on its name plate it can be installed in an explosion hazardous area</p> |
|  | <p>Explosion hazardous area Symbol used in drawings to indicate explosion hazardous areas. Devices located in and wiring entering areas with the designation “explosion hazardous areas” must conform with the stated type of protection.</p> |
|  | <p>Safe area (non-explosion hazardous area) Symbol used in drawings to indicate, if necessary, non-explosion hazardous areas. Devices located in safe areas still require a certificate if their outputs run into explosion hazardous areas</p> |
| Electrical symbols | |
|  | <p>Direct voltage A terminal to which or from which a direct current or voltage may be applied or supplied</p> |
|  | <p>Alternating voltage A terminal to which or from which an alternating (sine-wave) current or voltage may be applied or supplied</p> |
|  | <p>Grounded terminal A grounded terminal, which as far as the operator is concerned, is already grounded by means of an earth grounding system</p> |
|  | <p>Protective grounding (earth) terminal A terminal which must be connected to earth ground prior to making any other connection to the equipment</p> |
|  | <p>Equipotential connection (earth bonding) A connection made to the plant grounding system which may be of type e.g. neutral star or equipotential line according to national or company practice</p> |
|  | <p>Temperature resistance of the connection cables States, that the connection cables must be resistant to a temperature of at least 85 °C.</p> |

2 Identification

2.1 Device designation

2.1.1 Nameplate

You will find the following technical data on the device's nameplate:

| | |
|---|---|
| Endress+Hauser  | |
| Silopilot M FMM 50 | Order number |
| Order Code: _____ | Serial number |
| Ser. No: _____ | |
| ⊖ 180 - 253 V AC | Supply voltage |
| 230 VA Contact rating max! | |
| 50/60 Hz I 250 V AC | Communication variant |
| ⊕ 4 - 20 mA 6 A | |
|  II 1/2 D IP67 T99°C BVS 05 ATEX E... | Identification in accordance with Directive 94/9/EC and identification of type of explosion protection |
| -20°C < Tamb < +70°C | |
|  →  BA286F/.. | Reference to additional (safety-relevant) documentawöhrtion |
|  0032 | |
| Made in Germany D-79689 Maulburg | |

2.1.2 Product structure

2.1.2.1 Ordering information for the Silopilot M FMM50

| | | | | |
|-----------|--|---|--|--|
| 10 | Approval: | | | |
| | A | Non-hazardous area | | |
| | B | ATEX II 1/2D IP67 T99°C | | |
| | Y | Special version, to be specified | | |
| 20 | Housing: | | | |
| | 1 | Aluminum | | |
| | 2 | Aluminum, coated | | |
| | 9 | Special version, to be specified | | |
| 30 | Motor traction: | | | |
| | A | max. 200 N, bulk density low | | |
| | B | max. 500 N, bulk density high | | |
| | Y | Special version, to be specified | | |
| 40 | Measurement range: | | | |
| | 1 | 25 m | | |
| | 2 | 35 m | | |
| | 3 | 50 m | | |
| | 4 | 70 m | | |
| | 9 | Special version, to be specified | | |
| 50 | Maximum connection height; wiper: | | | |
| | A | 230 mm, aluminum/steel | | |
| | B | 230 mm, stainless steel | | |
| | C | 500 mm, aluminum/steel | | |
| | D | 500 mm, stainless steel | | |
| | E | 1000 mm, aluminum/steel | | |
| | F | 1000 mm, stainless steel | | |
| | Y | Special version, to be specified | | |
| 60 | Power supply: | | | |
| | 1 | 180 - 253 VAC, 50/60 Hz | | |
| | 2 | 90 - 127 VAC, 50/60 Hz | | |
| | 9 | Special version, to be specified | | |
| 70 | Output: | | | |
| | A | 0/4 - 20 mA + 2x relay, function selectable | | |
| | B | 0/4 - 20 mA + 6x relay, function selectable | | |
| | | Relay function: counting, reverse, upwards, max pos., alarm limit, measuring active | | |
| | Y | Special version, to be specified | | |

2.1.2.2 Comments regarding the product structure

The following limitations apply to devices with an ATEX license:

- **Ambient temperature (80), option B:** min. -35°C
- **Process temperature (90):** only (1)
- **Process pressure (100):** only (1)
- **Sensing weights (110):** (G) and (M) not permitted
- **Additional equipment (120):** (2) not permitted

The following limitations apply to devices with a process temperature range of up to +230°C:

- **Max. connection height; wiper (50):** only (E) or (F)
- **Sensing weights (110):** (D), (E), (G) and (M) not permissible

Other limitations:

- **Ambient temperature (80), option C:** only in conjunction with coated housing

The suitable mounting aid (bubble level) is only in versions with coated housing a part of the Silopilot.

2.2 Scope of delivery



Attention!

Always observe the information provided in the "Incoming acceptance, transport, storage" chapter relating to unpacking, transporting and storing measuring devices!

The scope of delivery consists of:

- Device (fitted)
- Possibly sensing weight
- Possibly accessories

Documentation supplied:

- Operating Instructions (this document)
- Approval documentation (unless provided in these Operating Instructions)

2.3 Certificates and approvals

2.3.1 CE mark, declaration of conformity

The device is built and tested in a reliable, state-of-the-art design and left the factory in perfect condition. The device complies with the relevant standards and specifications as defined in EN 61010 “Safety requirements for electrical equipment for measurement, control and laboratory use”. The device therefore satisfies the statutory requirements of the EC Directives.

By applying the CE mark, Endress+Hauser confirms that the device has passed the necessary tests. You will find a copy of the EC declaration of conformity in the Appendix 15.15.

2.3.2 Identification in accordance with Directive 94/9/EC (ATEX)

| | |
|---|--|
| | CE  II 1/2D IP67 T99°C |
| - Device group II | _____ |
| - Device category: Process category 1 (zone 20), Environment for category 2 (zone 21) | _____ |
| - Type of protection for housing in accordance with EN 60529 | _____ |
| - Maximum surface temperature at maximum permissible ambient temperature | _____ |

3 Sensing weights

3.1 Variants

The following forms are available and are described on the following pages:

- Normal weight (cylindrical sensing weight with spike) ①
- Umbrella weight ②
- Bag weight (in versions without ATEX certificate) ③
- Cage weight ④
- Oval float (in versions without ATEX certificate) ⑤
- Bell weight ⑥



3.1.1 Normal weight

- Application:
For coarse bulk solids, e.g. coals, ores or stones and granulates.
- The spike can be screwed off.
- If the bunker/silo has a downstream crushing or milling system, we recommend using the electrical signal function "tape breakage" or the use of a cage weight to avoid damaging the system in the event of the sensing weight breaking free.
- Materials:
Steel or stainless steel
- Weight:
3.5 kg

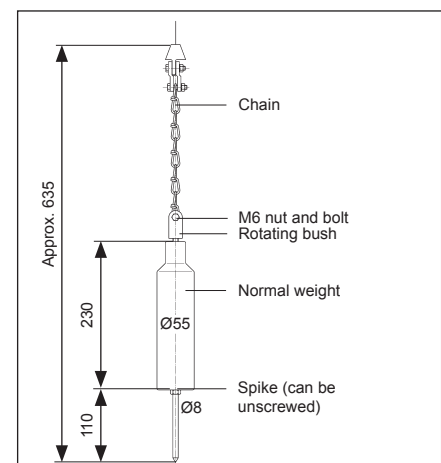

3.1.2 Umbrella weight

- Application:
For very light and loose bulk solids, e.g. flour or coal-dust.
- The umbrella weight has a large square surface area which prevents it from sinking deeply into the product.
- When folded closed, the weight can be passed through the DN100 mounting flange into the bunker.
- Maximum permissible temperature:
100°C
- Materials:
Steel or stainless steel, canvas
- Weight:
3.5 kg

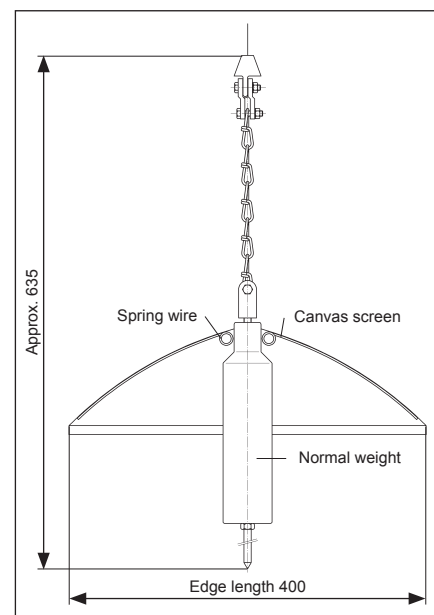

3.1.3 Bag weight

- Application:
In bunkers to which e.g. mills are connected downstream. The bag contains whichever product is contained within the bunker.
- Maximum permissible temperature:
100°C
- Materials:
Bag made of Nomex®, loops reinforced with felt, all metal parts made from stainless steel.
- Weight:
0.25 kg (empty) / 3.5 kg (filled)
- Bind the bag closed at the top so that the contents cannot fall out if the bag tips over on the slope of a product cone.
- Use of the bag weight for the "Dust ignition-proof" version is not permitted!

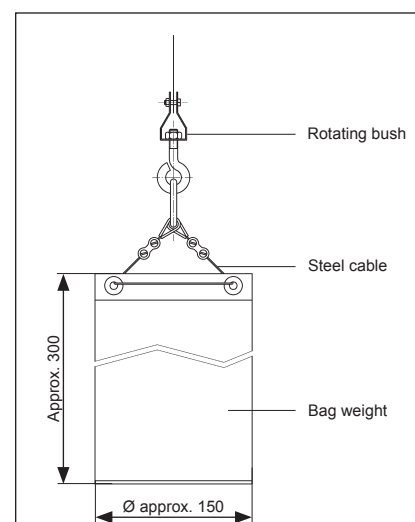

3.1.4 Cage weight

- Application:
For fine bulk solids in silos with relatively small outlet openings that must not be blocked by a sensing weight which has broken free.
- Also suitable for high temperatures for which a bag may not be used.
- The weight could become lodged over the product outlet – but would allow the bulk solid to pass through. Since the cage weight cannot enter a conveyor system (e.g. cellar wheel feeder or screw conveyor), no damage can result.
- Standard dimensions:
See illustration (other dimensions on request)
- Material:
Steel or stainless steel
- Weight:
3.5 kg

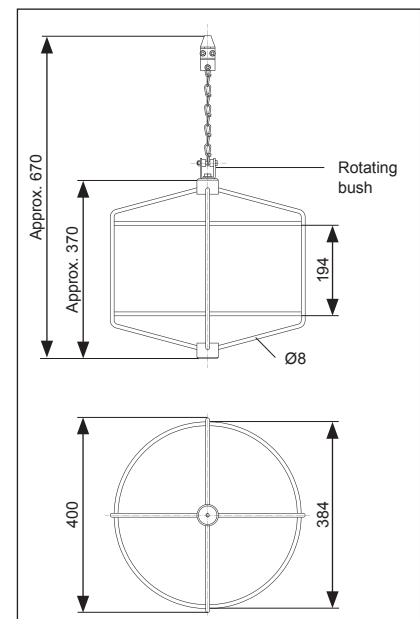

3.1.5 Oval float

- Application:
For liquids, e.g. fuel oil, also for granulates.
- Materials:
Hard PVC
- Maximum permissible temperature:
70°C
- The float must be filled with product to a total weight of 3.5 kg.
- Use of the oval float in the "Dust ignition-proof" version is not permitted!

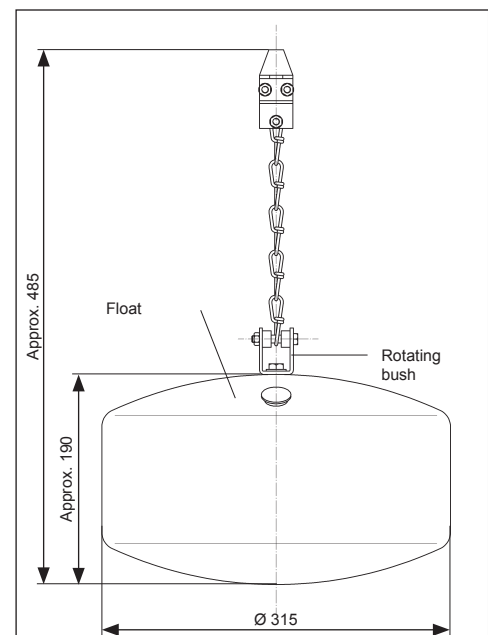

3.1.6 Bell weight

- Application:
For light and loose bulk solids; especially where higher temperatures and particular characteristics preclude the use of an umbrella weight.
- Materials:
Steel or stainless steel
- Weight:
4.3 kg

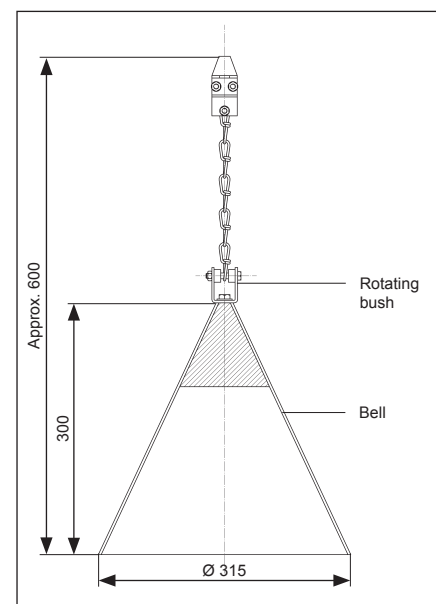

3.2 Selection recommendation

When selecting the sensing weight, the following points should be considered:

- The sensing weight must not sink into the product nor be diverted by contact with the product cone during the measuring procedure.
- The sensing weight must be suited to the chemical characteristics of the product and the temperature in the bunker or silo.
- Use of the oval float and bag weight in the "Dust ignition-proof" version is not permitted!

4 Installation

4.1 Planning the installation location

Select the installation location on the bunker or silo such that product falling inside during filling or cornices collapsing inward are prevented from covering the sensing weight or damaging the measuring tape.

Take due account of the shape and location of the product inflow cone and the outflow funnel within the vessel. The measuring path should not pass too close to any internal fixtures or struts so that the measuring tape will not brush against them if the sensing weight swings around.

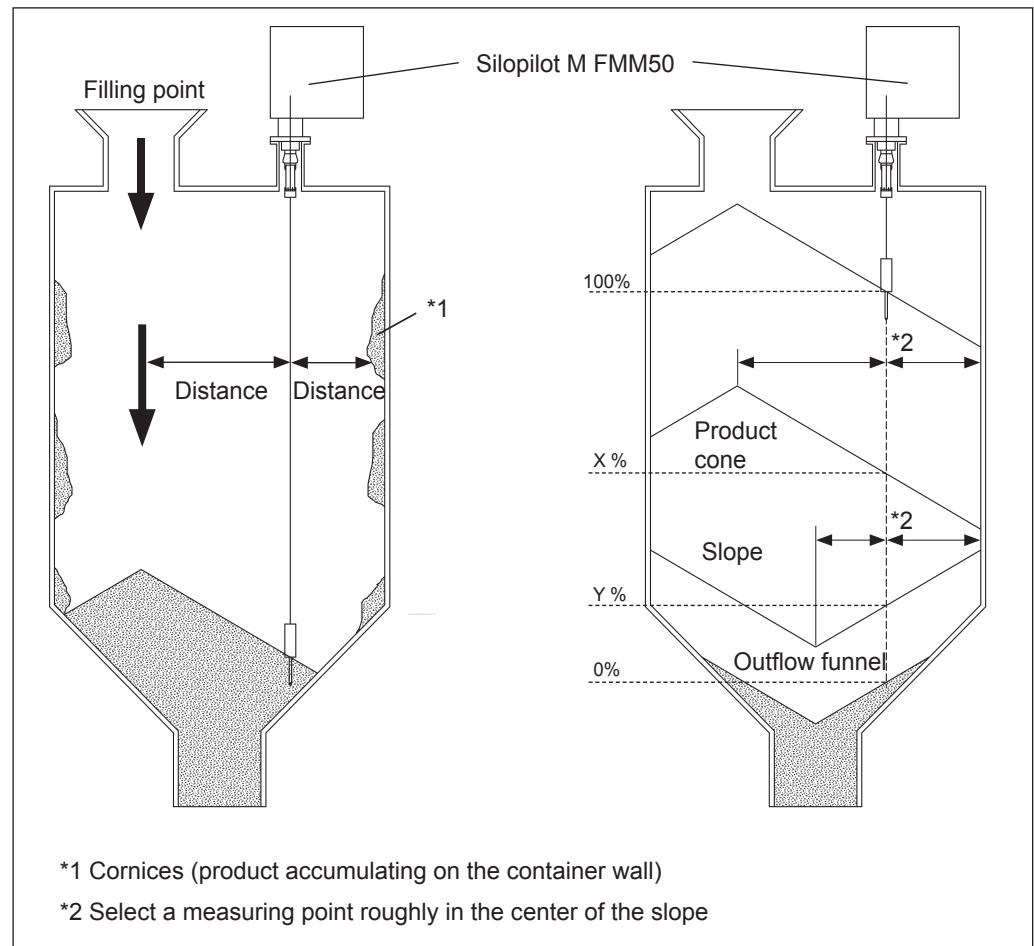

4.2 Installation conditions

4.2.1 Housing dimensions (standard version)

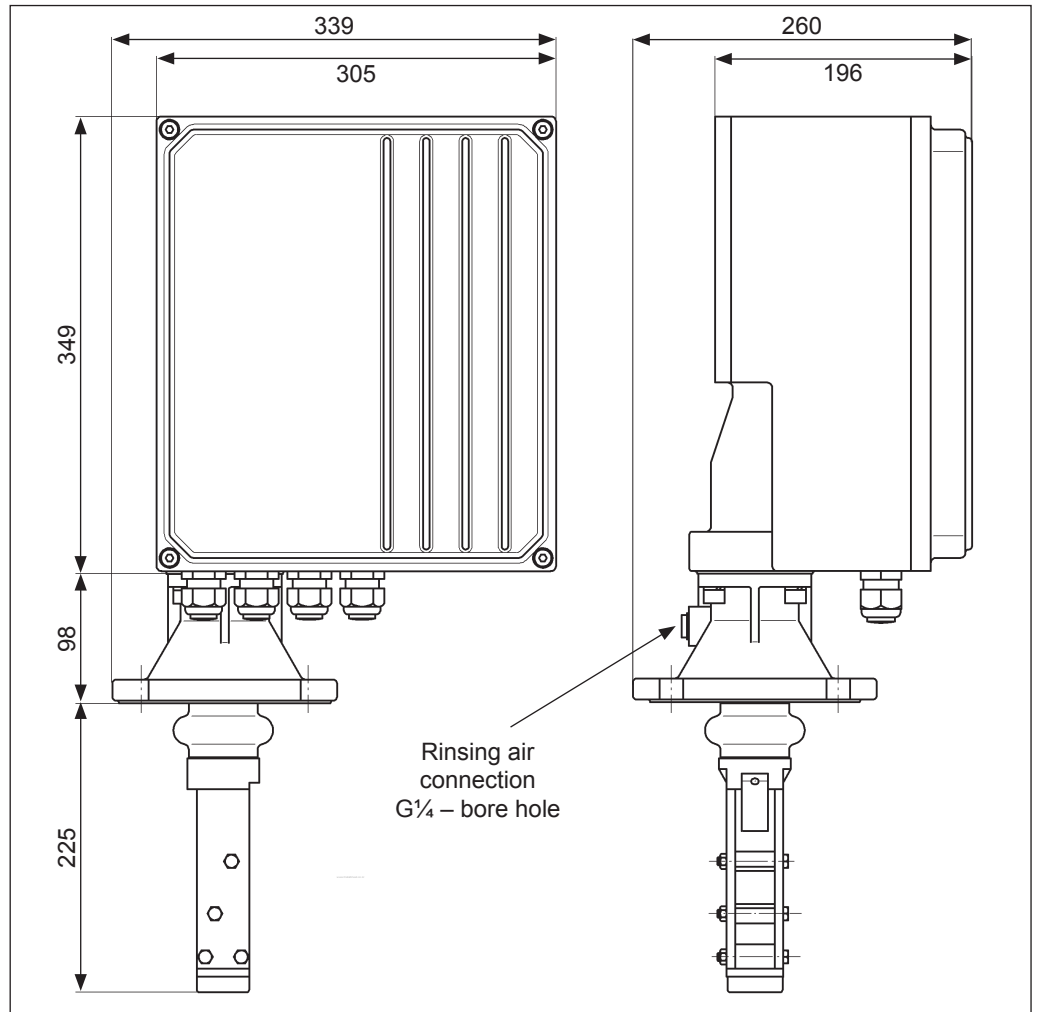

4.2.2 Dimensions of extended wiper

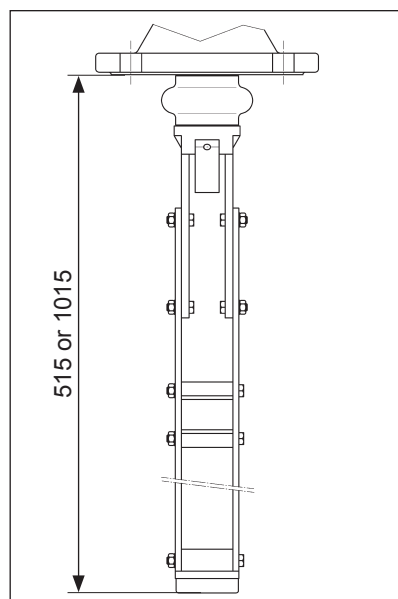

4.2.3 Dimensions of high-temperature version (up to +230°C)

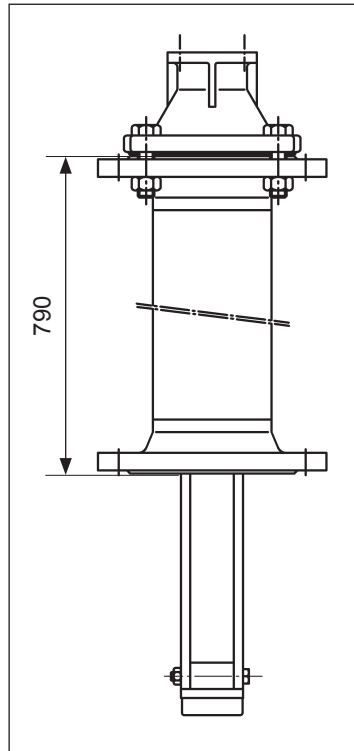

4.2.4 Dimensions of process connection (standard version)

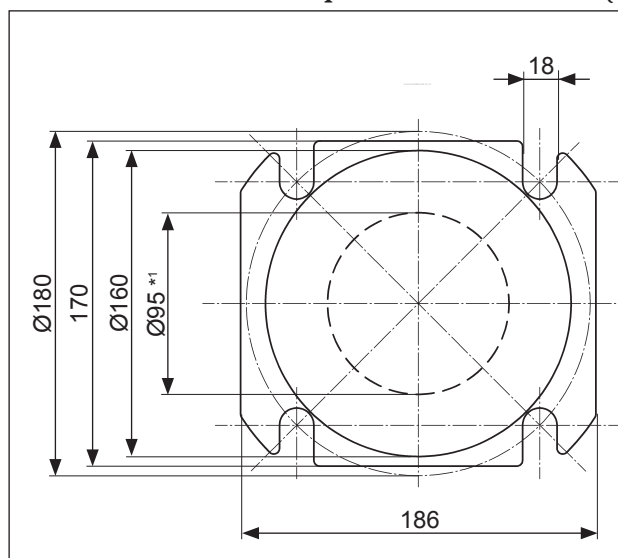

*1 Minimum dimension for installing the wiper mechanism and standard weight

4.2.5 Dimensions of process connection (high-temperature version)

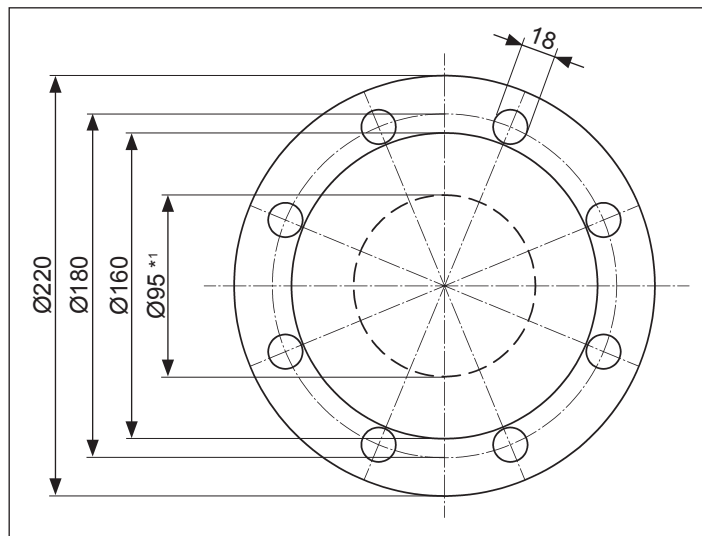

*1 Minimum dimension for installing the wiper mechanism and standard weight

4.2.6 Dimensions of optional window and external start button

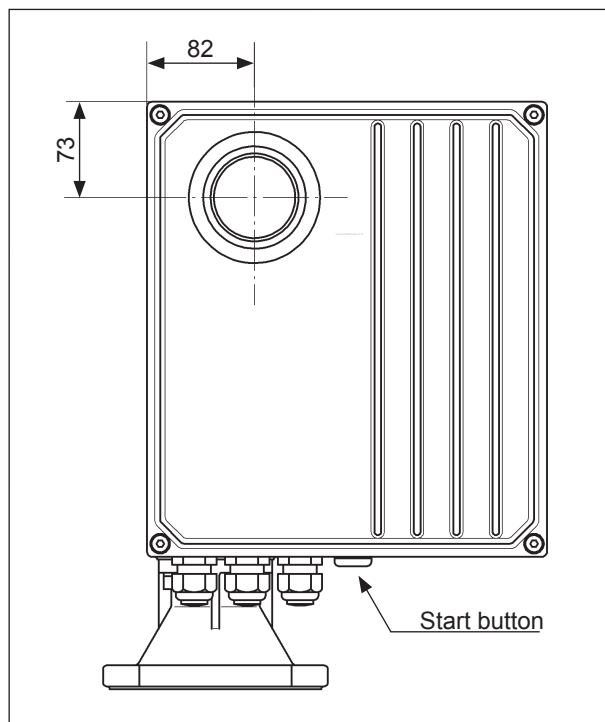

4.3 Installation preparation

The Silopilot is best mounted on a counter flange DN100 PN16 (connection dimensions acc. to DIN2501) or a flange with the same connection dimensions. Please refer to chapter 4.2 for dimensions

The counter flange must be mounted exactly horizontal so that the Silopilot can also be mounted horizontally onto it (maximum angle of inclination 2°). A suitable mounting aid (bubble level) can be found inside versions with a powder-coated housing. When the electronics cover is opened, this can be used for alignment.

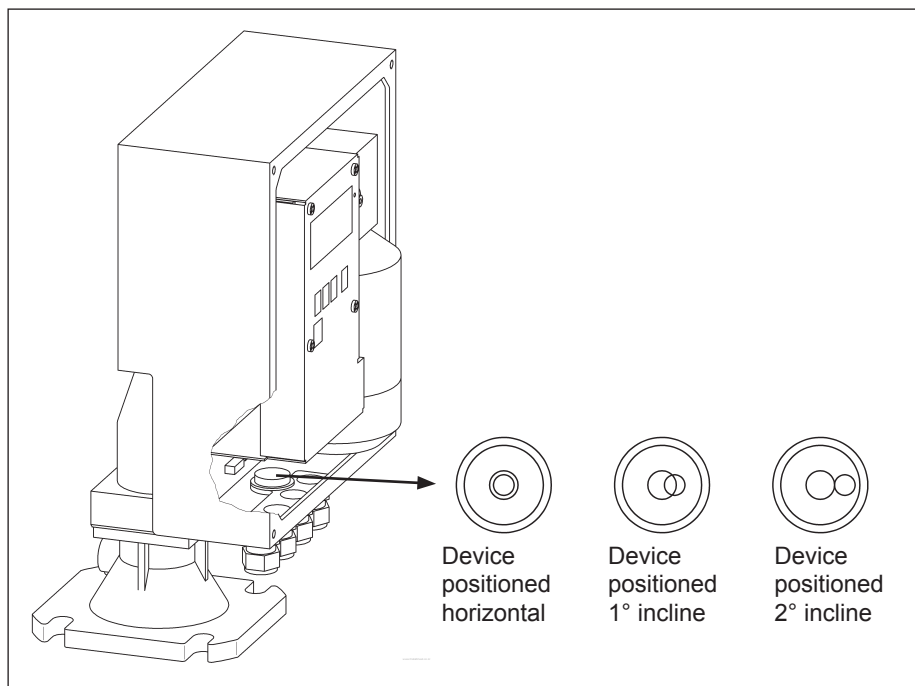

When installing outside, fit a protective hood or mount a weather protection cover.

4.4 Incoming acceptance, transport, storage

4.4.1 Incoming acceptance

Check whether the package or contents are damaged. Check that the goods supplied are complete and compare the scope of delivery with your order details.

4.4.2 Transport to the measuring point



Attention!

Observe safety instructions and transport conditions for devices weighing more than 18 kg. When transporting the measuring device, do not lift using the wiper or sensing weight.

4.4.3 Storage

The measuring device must be packaged with protection from impact for storage and transport. The permissible storage temperature is -40 °C ... $+80\text{ °C}$.

4.5 Installation

4.5.1 Installing the sensing weight

Normal weights, umbrella weights and bag weights (see chapter 3 "Sensing weights") can be passed through the DN100 mounting flange into the bunker or silo.

When using larger sensing weights, such as cage weights, bell weights, floats and some bag-type weights, access provision must be present in the design of the bunker or silo for installation of these weights.

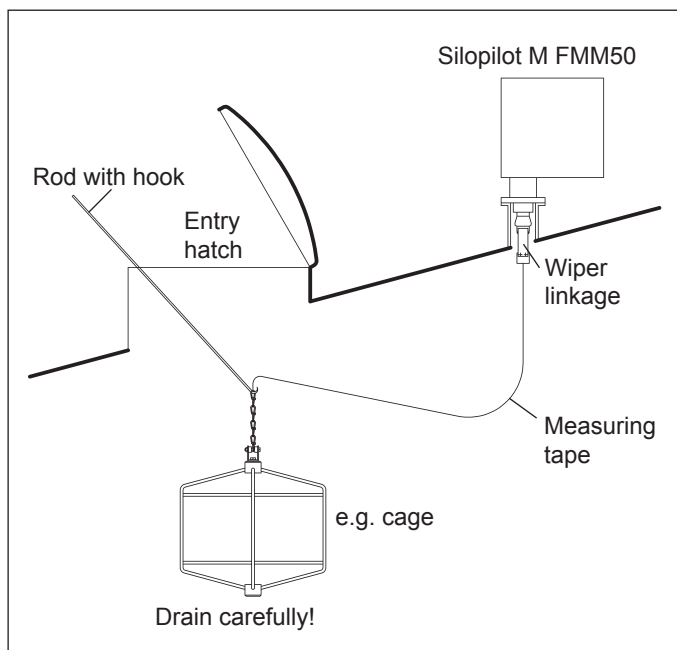

The measuring tape is pressed into the tape fastening by two screws. A third screw secures the chain. A rotating bush is mounted at the bottom end of the chain to accommodate any turning motion of the sensing weight.

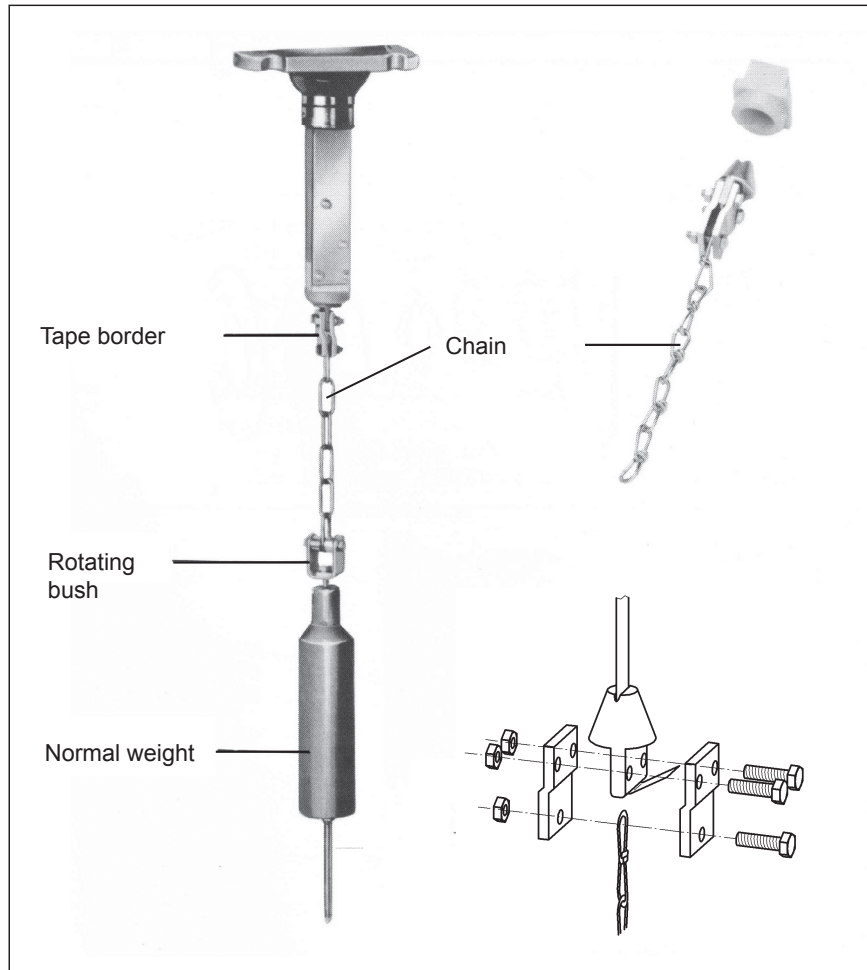

4.5.2 Installing the Silopilot

Fit a seal ring on the flange (particularly if there is positive pressure in the bunker or silo). Carefully guide the sensing weight into the bunker or silo. When using larger sensing weights, please refer to chapter 4.5.1 "Installing the sensing weight".

Now place the Silopilot onto the flange and secure it using four M16 bolts of a suitable length. Please note the following points:

- Take the position of cable entries for electrical connections into consideration (see housing dimensions in chapter 4.2).
- Install the Silopilot horizontally (see chapter 4.2 "Installation preparation").



Note!

When installing the Silopilot in bunkers or silos with heavy dust development, slight positive pressure can be generated at the Silopilot by connecting a compressed air line to its mounting flange (airflow quantity as required). There is a G $\frac{1}{4}$ female connection provided for this purpose (see housing dimensions in chapter 4.2).



Note!

The sensing weight must be outside the connection when the measuring tape is unwound. The maximum height of the connection is 230 mm when using the standard wiper. The wiper is also available in lengths of 500 mm and 1000 mm (see order code). Other lengths are available on request as special versions.

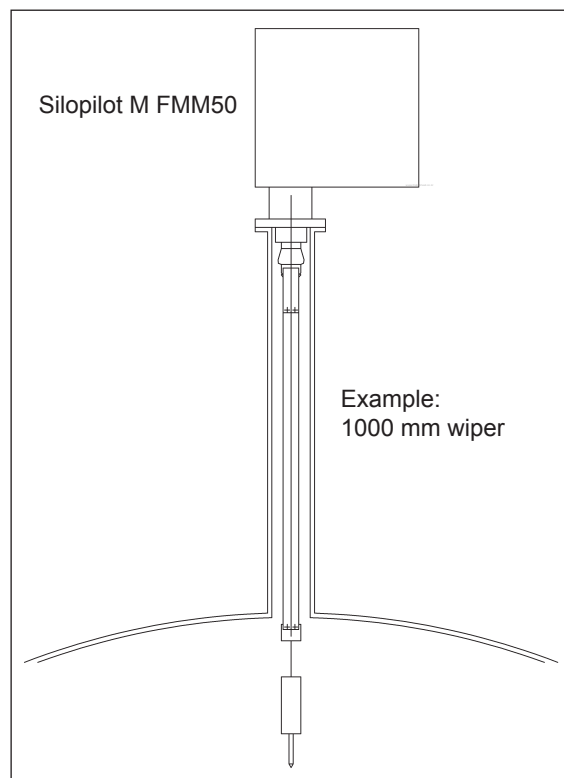

4.6 Post-installation check

Once the measuring device has been mounted, undertake the following checks:

- Is the measuring device damaged (visual check)?
- Does the measuring device corresponds to the specifications of the measuring point, such as process temperature, process pressure, ambient temperature, measurement range, etc.?
- Are the measuring point numbers and inscriptions correct (visual check)?
- Is the measuring device sufficiently protected from rain and direct sunlight (see chapter 4.3)?

5 Wiring

5.1 Electrical connection

Please note the following points before connecting up the device:

- The voltage supply must match the voltage specified on the nameplate.
- Switch off the supply voltage before connecting the device.
- Connect a potential matching line to the earthing terminal to be used on the Silopilot's housing before connecting the device.
- When using the device in explosion hazard zones, the corresponding national standards and specifications must be observed.



Warning!

Always observe the safety instructions on this provided in chapter 1 of these Operating Instructions!

5.2 Potential matching

The potential matching should be connected up to the outer earthing terminal of the Silopilot.

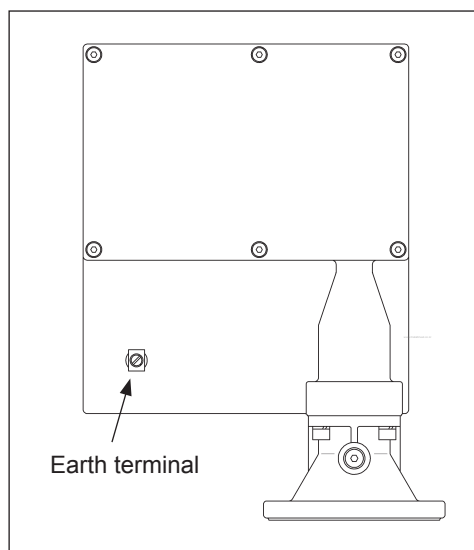

Note!

For optimum electromagnetic compatibility, the potential matching line should be as short as possible. The recommended minimum cable cross-section is 2.5 mm².



Attention!

The Silopilot's potential matching should be included in the local potential matching.

5.3 Terminal assignment

5.3.1 Overview

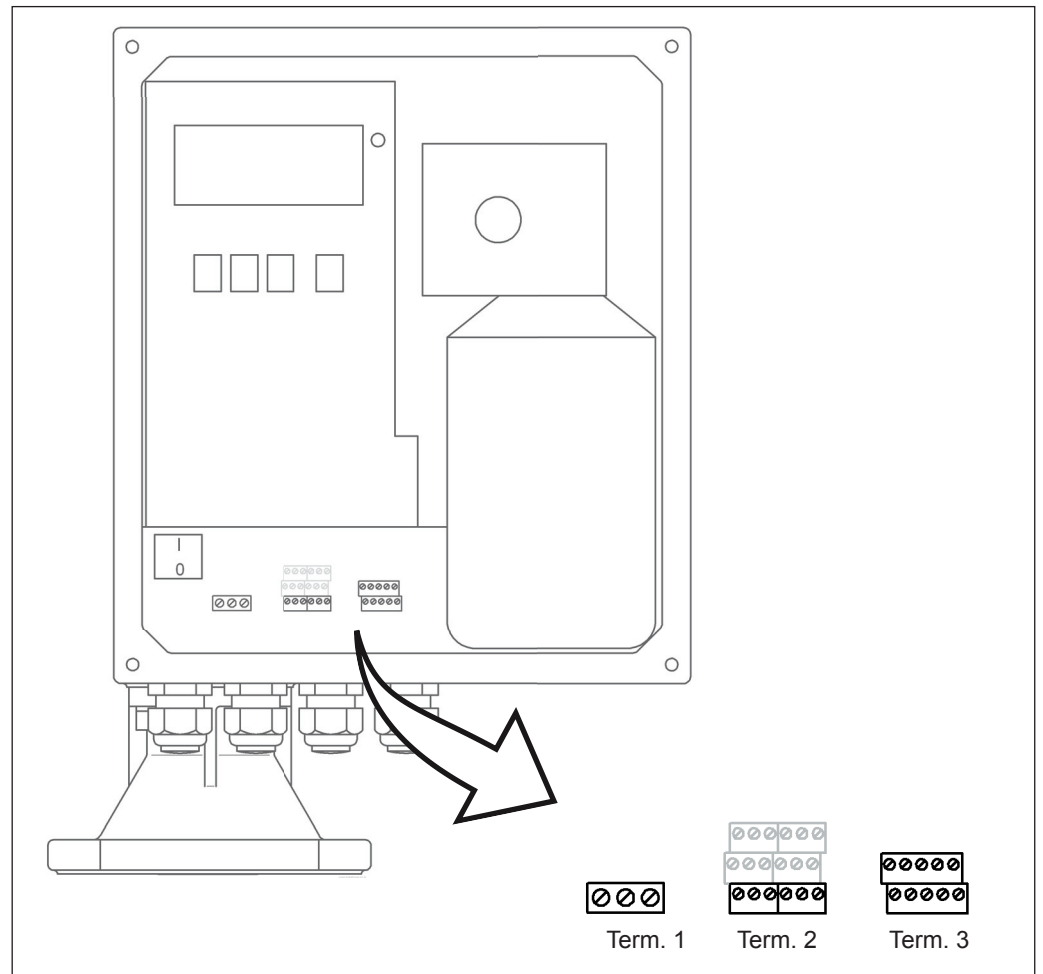

*1 optional, see type code

| Terminal | Function |
|-------------------------|---------------------------------|
| Term. 1 | Supply voltage |
| Term. 2.1 - term. 2.3 | Relay output 1 |
| Term. 2.4 - term. 2.6 | Relay output 2 |
| Term. 2.7 - term. 2.9 | Relay output 3 ^{*1} |
| Term. 2.10 - term. 2.12 | Relay output 4 ^{*1} |
| Term. 2.13 - term. 2.15 | Relay output 5 ^{*1} |
| Term. 2.16 - term. 2.18 | Relay output 6 ^{*1} |
| Term. 3.1 - term. 3.2 | Input 1 (active) ^{*2} |
| Term. 3.3 - term. 3.4 | Input 2 (active) ^{*2} |
| Term. 3.5 - term. 3.6 | Input 1 (passive) ^{*2} |
| Term. 3.7 - term. 3.8 | Input 2 (passive) ^{*2} |
| Term. 3.9 - term. 3.10 | 0/4 - 20 mA current output |

^{*2} input 1 and input 2 (active/passive) can only be used alternatively!
A double connection from input x active and passive cannot be used!

5.3.2 Supply voltage

- The supply voltage (mains voltage) is connected to the screw terminals on terminal 1.
- The maximum cable cross-section is 6 mm².
- A fuse should be fitted to protect the power supply against short circuits.
- Voltage range:
 - 180 ... 253 VAC, 50/60 Hz or
 - 90 ... 127 VAC, 50/60 Hz

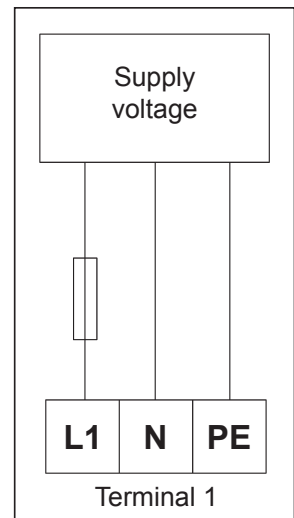

5.3.3 0/4 - 20 mA current output

- The active 0/4 - 20 mA current output is connected to the screw terminals on terminal 3.
- The maximum cable cross-section for the screw terminals is 1.5 mm².
- Normal installation cables are sufficient for making the connections.
- Load: max. 600 Ω

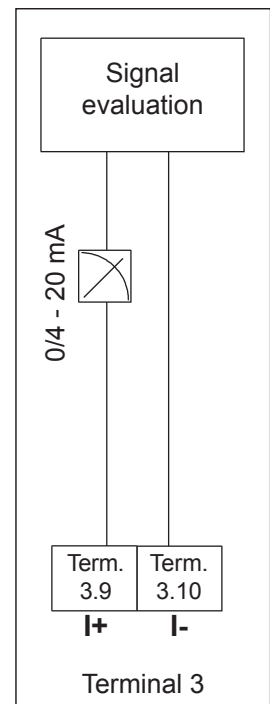

5.3.4 Relay outputs

- The connection cables of the relay outputs (relay 1 - relay 2 and optional relay 3 - relay 6) are connected to the screw terminals of terminal 2.
- The maximum cable cross-section for the screw terminals is 1.5 mm².
- Normal installation cables are sufficient for making the connections.
- The individual circuits must have a maximum of 6 A fuse protection.
- Contact load bearing capacity: 250 VAC, 6 A

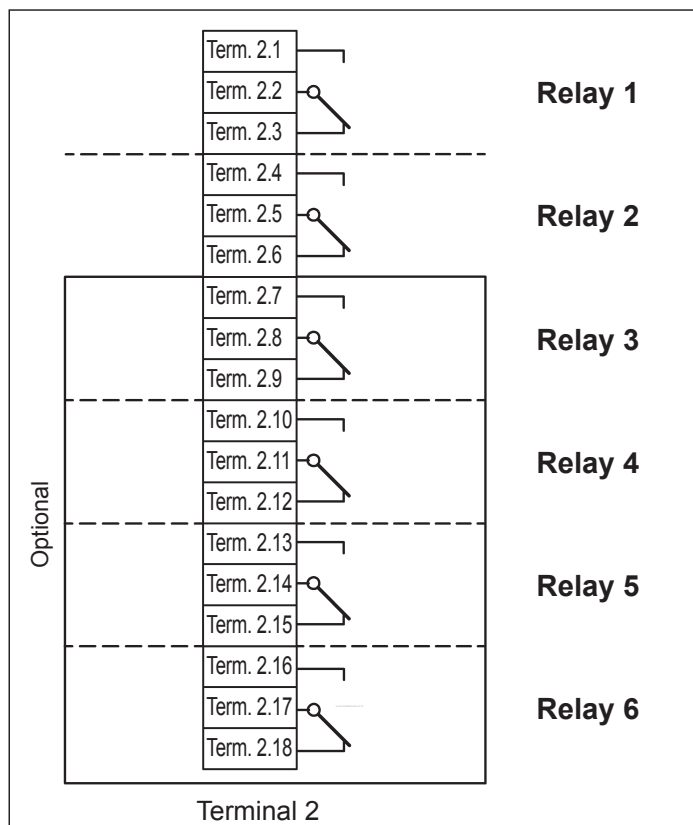

5.3.5 Signal inputs (active)

- The signal inputs are connected to the screw terminals on terminal 3.
- The maximum cable cross-section for the screw terminals is 1.5 mm².
- Normal installation cables are sufficient for making the connections.
- Input voltage range: 12 ... 24 VDC

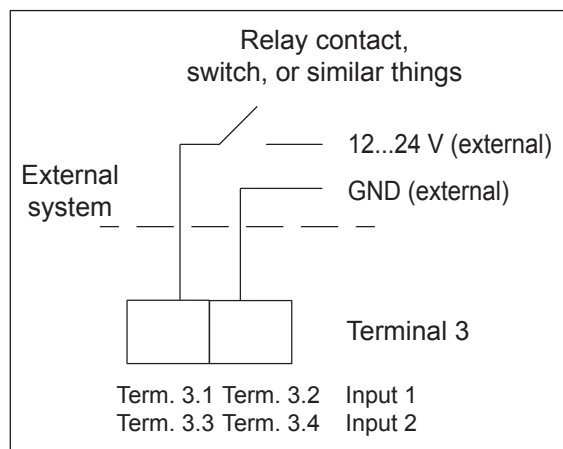

5.3.6 Signal inputs (passive)

- The signal inputs are connected to the screw terminals on terminal 3.
- The maximum cable cross-section for the screw terminals is 1.5 mm².
- Normal installation cables are sufficient for making the connections.
- Contact load: max. 5 mW

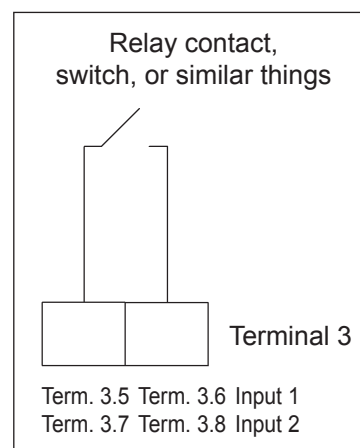

Note!

- The signal inputs (active/passive) can only be used alternatively. A double connection from input x active and passive cannot be used!
- In the device version with an external start button (Silopilot M FMM50 - *****2), this is connected to the passive signal input 1. Only signal output 2 is then available to you as active or passive.

5.4 Post-connection check

Please undertake the following checks after wiring up the measuring device:

- Is the terminal assignment correct?
- Is the cable gland sealed?
- If power supply is present:
Is the measuring device ready and is the LCD display lit up?
- Is the housing cover screwed shut?

6 Operation

6.1 Quick operation guide

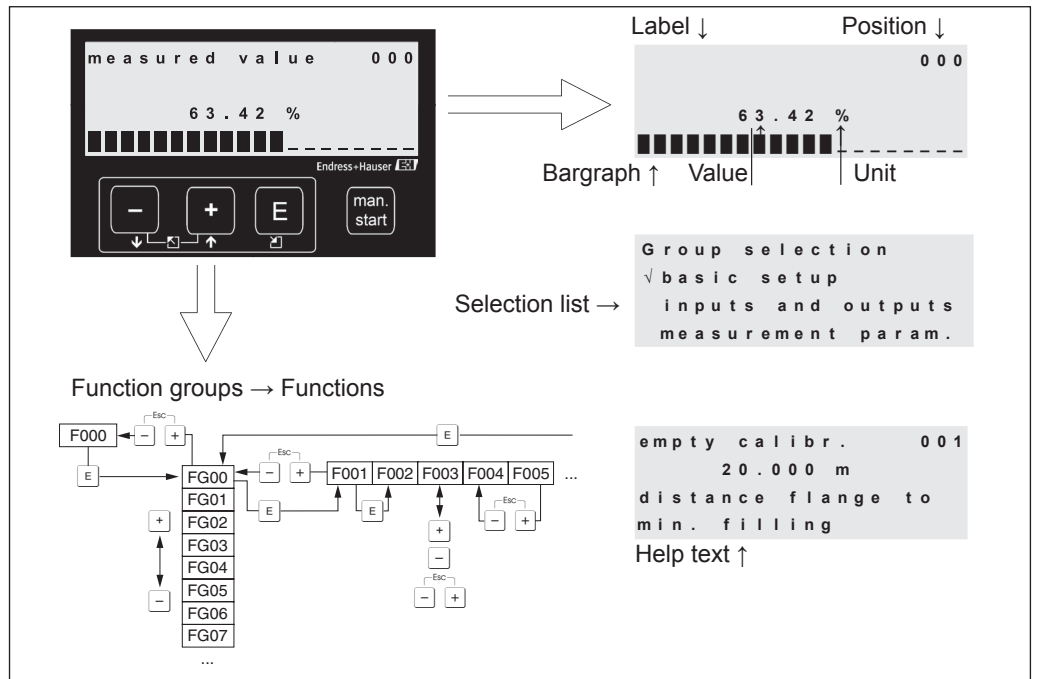

Selection and configuration in the operating menu:

1. Use **E** to switch from the measured value display to **group selection**.
2. Use **-** or **+** to select the **function group** required (e.g. "Safety settings (04)") and confirm by pressing **E**. The first **function** (e.g. "Current on alarm (040)") is selected.



Note!

The active selection is indicated by a ✓ in front of the menu text!

3. Editing mode is activated by pressing **+** or **-**.

Selection menus:

- a) In the **function** selected (e.g. "Current on alarm (040)"), **-** or **+** can be used to select the parameter required.
- b) **E** confirms the selection. ✓ appears in front of the parameter selected.
- c) **E** confirms the value edited. Editing mode is quit.
- d) **+** + **-** (= **Esc**) cancels the selection. Editing mode is quit.







Numbers and text entry:

- a) The first digit of the **number/text** can be edited by pressing **+** or **-** (e.g. "Current on alarm (040)").
 - b) **E** moves the input screen to the next digit. Continue with (a) until the value has been fully entered or modified.
 - c) When the symbol "→" appears in the input screen, use **E** to adopt (save) the value.
 - d) **+** + **-** (= **Esc**) cancels the entry. Editing mode is quit.
4. Use **E** to select the next **function** (e.g. "Min. safety (042)").
 5. Entering **+** + **-** (= **Esc**) takes you back to the last **function**.
 Entering **+** + **-** (= **Esc**) again takes you to **group selection**.
 Entering **+** + **-** (= **Esc**) again takes you back to the **measured value display**.

6.2 Display and operating elements









6.2.1 Display symbols

The following table describes the symbols used in the display:

| Symbol | Meaning |
|---|---|
|  | Alarm symbol - This alarm symbol is shown when the device is in an alarm status (error status). - If the symbol is flashing, a fault has occurred. |
|  | Lock symbol - This lock symbol is when the device is locked, i.e. when no energy is available. |
|  | COM symbol - This communication symbol is shown when data transfer is taking place. |
|  | Hand symbol - This symbol flashes when the device is in the "Manual mode" type of measurement. - When the  or  button is pressed, the symbol disappears and the direction selected (run-up ↑ or run-off ↓) is shown. |

6.2.2 Function of buttons

The following table describes the function(s) of the individual buttons:

| Button(s) | Meaning |
|--|--|
|  or  | - Upwards navigation in the selection list - Edit the numerical values within a function |
|  or  | - Downwards navigation in the selection list - Edit the numerical values within a function |
|   or  | - Navigation to the left within a function group |
|  | - Navigation to the right within a function group - Confirmation |
|  or external start button | - Starts measurement process (provided that the Silopilot is in the measured value display function) |

6.2.3 LED

The green LED positioned to the right of the LC display is used to display the pulse of the toothed wheel during a measurement process. The counting wheel emits a pulse to the evaluation electronics every 5 cm of tape length. The status of the LED changes at the same time. Once the measurement process is complete, the last LED status is retained.

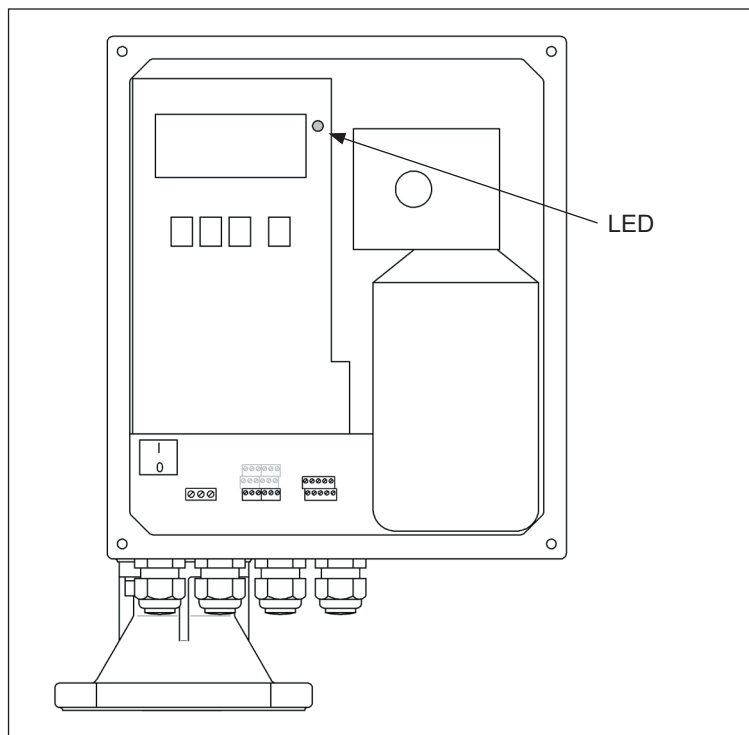

6.3 General structure of operating menu

The operating menu consists of two levels:

- **Function groups (00, 01, ..., 08):**

The individual possible ways of operating the device are divided roughly into function groups. Function groups available are e.g.: "**basic setup**", "**inputs and outputs**", "**safety settings**", "**linearization**", etc.

- **Functions (001, 002, ..., 083):**

Each function group consists of one or more functions. The actual operation and/or setting of parameters for the device takes place in the functions. Numerical values can be entered here and parameters selected and saved. Functions available from the "**inputs and outputs (01)**" function group are e.g.: "**input 1 (010)**", "**polarity input 1 (011)**", "**relay output 1 (014)**", etc.

If e.g. the polarity of input 1 is to be changed, the following procedure applies:

1. Select the function group "**inputs and outputs (01)**"
2. Select the function "**polarity input 1 (011)**"
3. Select "NC contact" (normally closed contact) or "NO contact" (normally opened contacted)

7 Commissioning

Ensure that the post-installation check and post-connection check have been undertaken before you start up your measuring point:

- Checklist "Post-installation check" (see chapter 4.5)
- Checklist "Post-connection check" (see chapter 5.4)

7.1 Switching on measuring device

If the device is being switched on for the first time, the following appears on the display:

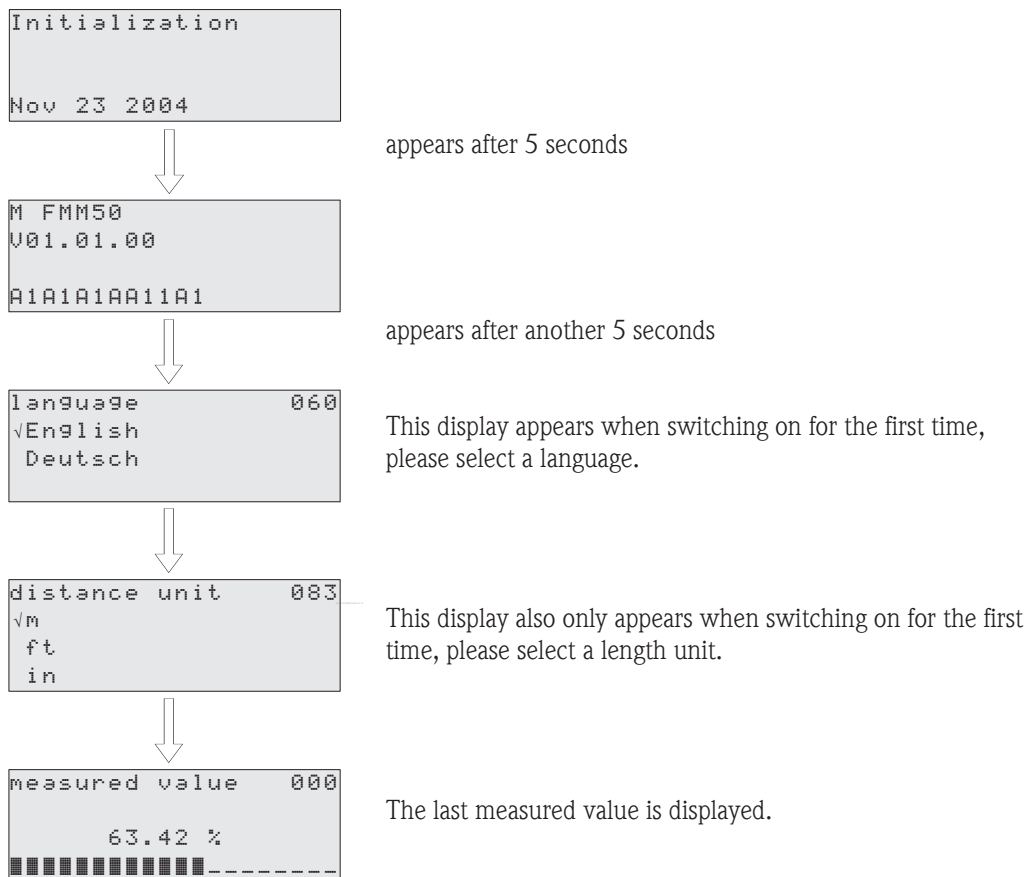

Note!

A measurement must first be undertaken before a measured value valid for the current system can be obtained.

7.2 Basic setup

In most cases, the basic calibration is sufficient for successful commissioning. More complex measurement tasks may however require further settings. For the details of all functions, please see chapter 8.

You will find a table in the appendix detailing the values preset in the factory.

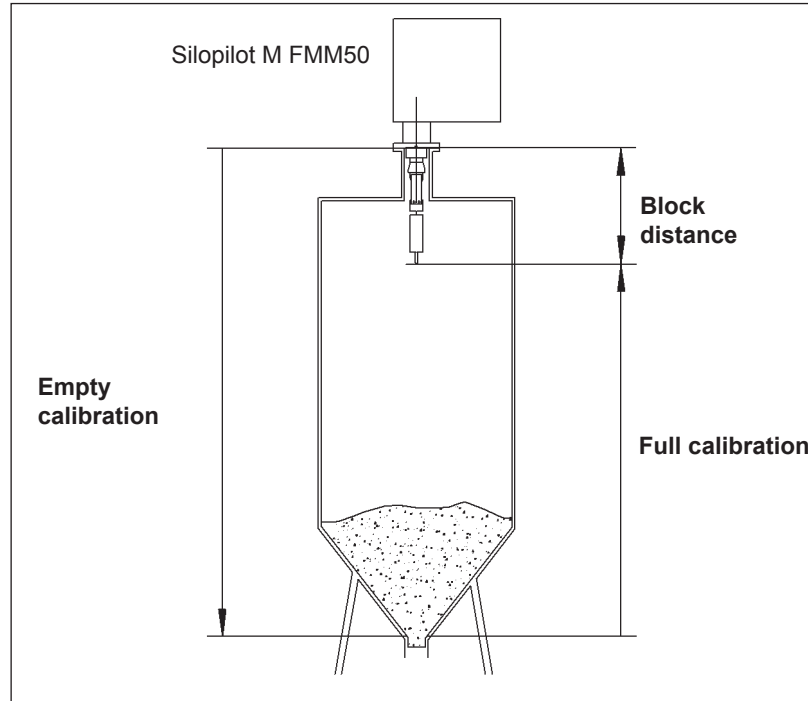

7.2.1 Empty calibration (001)

```
empty calibr.    001
                 35 m
distance flange to
min. filling
```

With this function, you enter the distance between the mounting flange (reference point for measurement) and the minimum fill level (=zero point).

Range of values: 1 m ... length of measuring tape
(or converted value in feet/inches)

Default value: length of measuring tape

7.2.2 Block distance (002)

```
block distance  002
                 0.80 m
distance flange to
bottom weight
```

With this function, you enter the distance between the flange of the Silopilot and the end of the sensing weight (in upper limit position).

Range of values: 0.23 m ... 5 m
(or converted value in feet/inches)

Default value: 0.8 m

7.2.3 Full calibration (003)

```
full calibration 003
      34 m
measuring range
max.=empty-bd
```

With this function, you enter the distance between the minimum fill level (=zero point) and maximum fill level (=measurement range).

Range of values: 1 m ... empty calibration - Block distance (or converted value in feet/inches)

Default value: Length of measuring tape - 0.8 m

7.2.4 Type of measurement (020)

```
measurement type 020
√single cycle
periodical
manual
```

With this function, you select the type of measurement for the Silopilot:

- **Single cycle:** A single measurement can be activated manually using buttons on the device or using a corresponding input signal (see chapter 7.2, functions 010 and 012).
- **Periodical:** The Silopilot can take time-controlled measurements. The time interval can be defined in functions 021 and 022 (see chapter 7.3).
- **Manual:** The Silopilot can only be operated using the buttons on the device. This type of measurement gives the user the opportunity to move the sensing weight slowly (e.g. when changing the cage sensing weight). For a precise description of this type of measurement, please refer to chapter 9.

Default value: Single cycle

8 Description of device functions

8.1 "Basic setup (00)" function group

In most cases, basic setup is sufficient for successful commissioning. More complex measurement tasks may however require further settings.

Please refer to this and the following sections for details. You will find a table in the appendix to these operating instructions detailing the values preset in the factory.

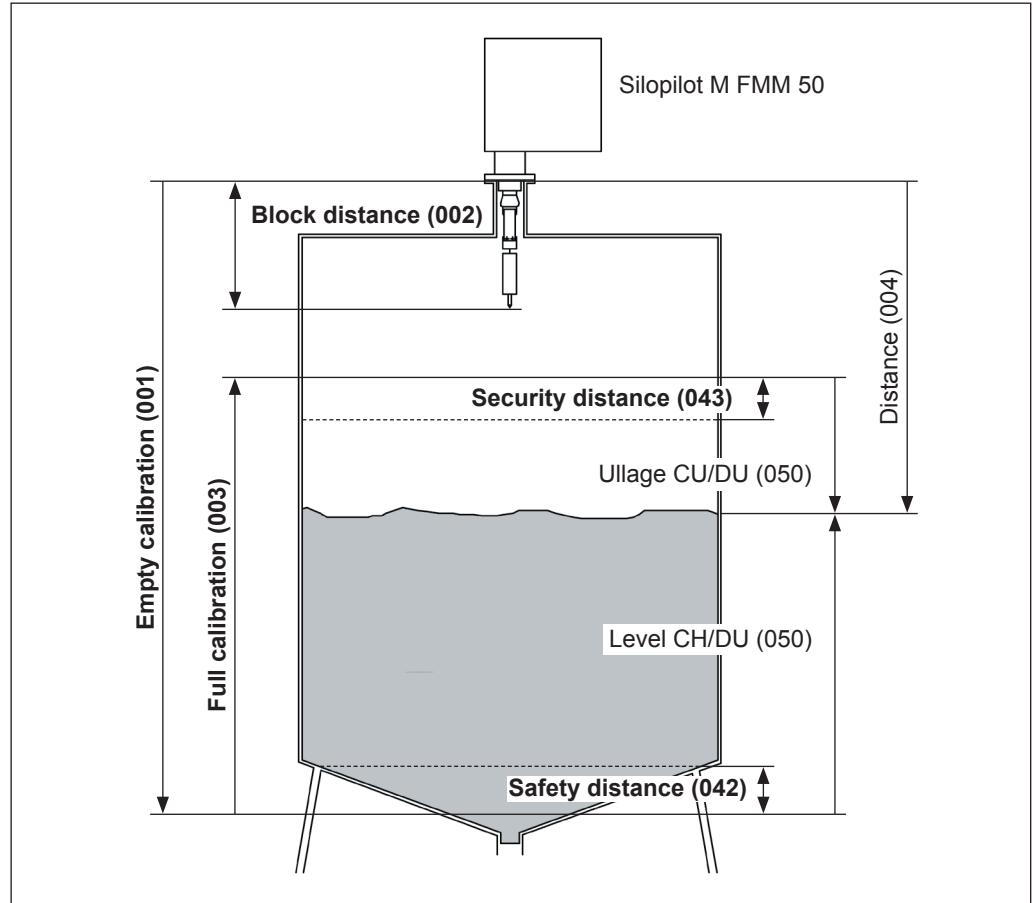

8.1.1 Empty calibration (001)

```
empty calibr. 001
      35 m
distance flange to
min. filling
```

With this function, you enter the distance between the mounting flange (reference point for measurement) and the minimum fill level (=zero point).

Range of values: 1 m ... length of measuring tape
(or converted value in feet/inches)

Default value: Length of measuring tape

8.1.2 Block distance (002)

```
block distance 002
      0.80 m
distance flange to
bottom weight
```

With this function, you enter the distance between the flange of the Silopilot and the end of the sensing weight (in upper limit position).

Range of values: 0.23 m ... 5 m
(or converted value in feet/inches)

Default value: 0.8 m

8.1.3 Full calibration (003)

```
full calibration 003
      34 m
measuring range
max.=empty-bd
```

With this function, you enter the distance between the minimum fill level (=zero point) and maximum fill level (=measurement range).

Range of values: 1 m ... empty calibration - block distance (or converted value in feet/inches)

Default value: Length of measuring tape - 0.8 m

8.1.4 Type of measurement (020)

```
measurement type 020
√single cycle
periodical
manual
```

With this function, you select the type of measurement for the Silopilot:

- **Single cycle:** A single measurement can be activated manually using buttons on the device or using a corresponding input signal (see function 010/012).
- **Periodical:** The Silopilot can take time-controlled measurements. The time interval can be defined in the 021/022 functions.
- **Manual:** The Silopilot can only be operated using the buttons on the device. This type of measurement gives the user the opportunity to move the sensing weight slowly (e.g. when changing to larger sensing weights). For a precise description of this type of measurement, please refer to the corresponding chapter .

Default value: Individual measurement



Warning!

When in manual mode, the upper limit switch and the loose band switch have no function! Users must themselves ascertain the position in which the sensing weight is currently located. With this type of measurement, the sensing weight can (depending on the maximum tape length) be lowered into unauthorized areas of the container (or e.g. in an outlet worm).



Note!

A measurement can only be taken when the device is in the measured value display (000). This also applies to the device version with an external start button.

8.1.5 Distance/measured value (004)

```
dist./meas.value 004
distance 0.90 m
meas.val 3.75 %
```

With this function, you can display the distance measured between the Silopilot and product and the current measured value. The display depends on the digits after the decimal place (function 062), length unit (function 083) and possibly . linearization.

8.2 "Inputs and outputs (01)" function group

The entries made in this function group determine the characteristics of the inputs and relay outputs.

8.2.1 Input 1 (010)

```
input 1          010
√not used
  bolting
  start measurement
```

With this function, you determine the characteristics of input 1:

- **Not used**
- **Bolting:** If there is a signal at input 1 (also see function 011), the Silopilot is blocked for further measurements. If necessary, the sensing weight is moved into the upper limit position, the measurement is canceled immediately.
- **Start measurement:** If there is a signal at input 1, the Silopilot starts a new measurement.

Default value: No function



Note!

In the device version with an external start button, this is connected to input 1. The function is then set to "Start measurement" in the factory.

8.2.2 Polarity of input 1 (011)

```
Polarity input 1 011
√NO contact
  NC contact
```

With this function, you determine the polarity of input 1, if "bolting" or "start measurement" has been selected in function 010:

- **Normally closed (NC) contact:** The input function becomes active if the input contact is opened (passive input) or the voltage level falls (active input).
- **Normally open (NO) contact:** The input function becomes active if the input contact is closed (passive input) or there is voltage (active input).

Default value: Normally open contact

8.2.3 Input 2 (012)

```
input 2          012
√not used
  bolting
  start measurement
```

With this function, you determine the characteristics of input 2. The selection options available are identical to those for input 1 (see function 010).

Default value: Not used

8.2.4 Polarity of input 2 (013)

```
Polarity input 2 013
√NO contact
  NC contact
```

With this function, you determine the polarity of input 2. The selection options available are identical to those for input 1 (see function 011).

Default value: Normally open contact

8.2.5 Relay for output 1 (014)

```
relay output 1 014
√alarm
threshold
service interval
```

With this function, you determine the characteristics of the relay for output 1:

- **Alarm:** Relay switches as soon as an error (e.g. tape breakage or burying) is detected.
- **Threshold:** Relay switches as soon as a set limit value (see function 017 and 018) is exceeded or not reached.
- **Service interval:** Relay switches when the value set in the maintenance interval (024) function is reached.
- **Counter pulses:** Relay switches at the impulse value set in function 015 and with the counter impulse length set in function 016.
- **Reset pulse:** Relay switches at the reset pulse length set in function 019 before a new measurement. This output can be used to reset an external counter.
- **Band return :** Relay switches during reversal in direction of tape from tape run off to tape run up.
- **Running up:** Relay switches when running up the sensing weight.
- **Top position:** Relay switches as soon as the upper limit position of the sensing weight (end of measurement) is reached.
- **Measuring:** Relay switches during the entire Silopilot measuring period.

Default value: Alarm

8.2.6 Relay for output 2 (01A) to relay for output 6 (01E)

The functionality of the outputs correspond to those of the relay for output 1 (see function 014). Outputs 3 (01C) to output 6 (01E) are only available as options. Please refer to the product structure in chapter 2 for details.

Default value:

| | |
|--------------------------|------------------|
| Relay for output 2 (01A) | Service interval |
| Relay for output 3 (01B) | Measuring |
| Relay for output 4 (01C) | Threshold |
| Relay for output 5 (01D) | Reset pulse |
| Relay for output 6 (01E) | Band return |

8.2.7 Pulse weight (015)

```
Pulse weight 015
  10
length per pulse
output = value * 5cm
```

With this function, you enter the move distance per pulse at the counting output. The distance is calculated from the value set $\times 5$ cm.

Range of values: 1 ... 20 (= 5 cm ... 100 cm or the value converted into feet/inches)

Default value: 1

Example (see illustration):

Every 0.2 m of move distance (pulse valve = 4) issues the preset counting pulse output e.g. relay 1, one counting pulse. You can enter the length of this pulse in the "**pulse length (016)**" function.

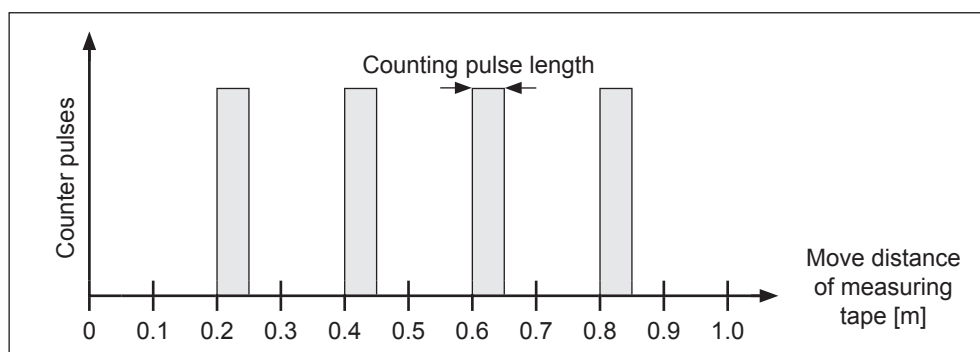

8.2.8 Pulse length (016)

```
Pulse length 016
  50 ms
length of the
counter pulse
```

With this function, you enter the length of the counter pulses in milliseconds. In such cases, the range of values depends on the pulse weight (015).

Range of values: 30 ms ... 100 ms [pulse weight = 1]
 30 ms ... 250 ms [pulse weight = 2]
 30 ms ... 400 ms [pulse weight = 3]
 30 ms ... 550 ms [pulse weight = 4 .. 20]

Default value: 50 ms

8.2.9 Limit value (017)

```
Limit value 017
  60.00 %
relative to the
full scale (003)
```

With this function, you determine the limit value of the relay outputs, when e.g. "limit value" has been selected in function 014, as a percentage of the measurement range (fill level).

Range of values: 0% ... 100%

Default value: 60%

8.2.10 Hysteresis (018)

```

hysteresis      018
      10.00 %
relative to the
full scale (003)
    
```

With this function, you determine the hysteresis of the relay outputs, when e.g. "limit value" has been selected in function 014, as a percentage of the measurement range (fill level). In such cases, the value entered relates to the limit value specified in function 017 not being reached.

Range of values: 0% ... 100%

Default value: 3%

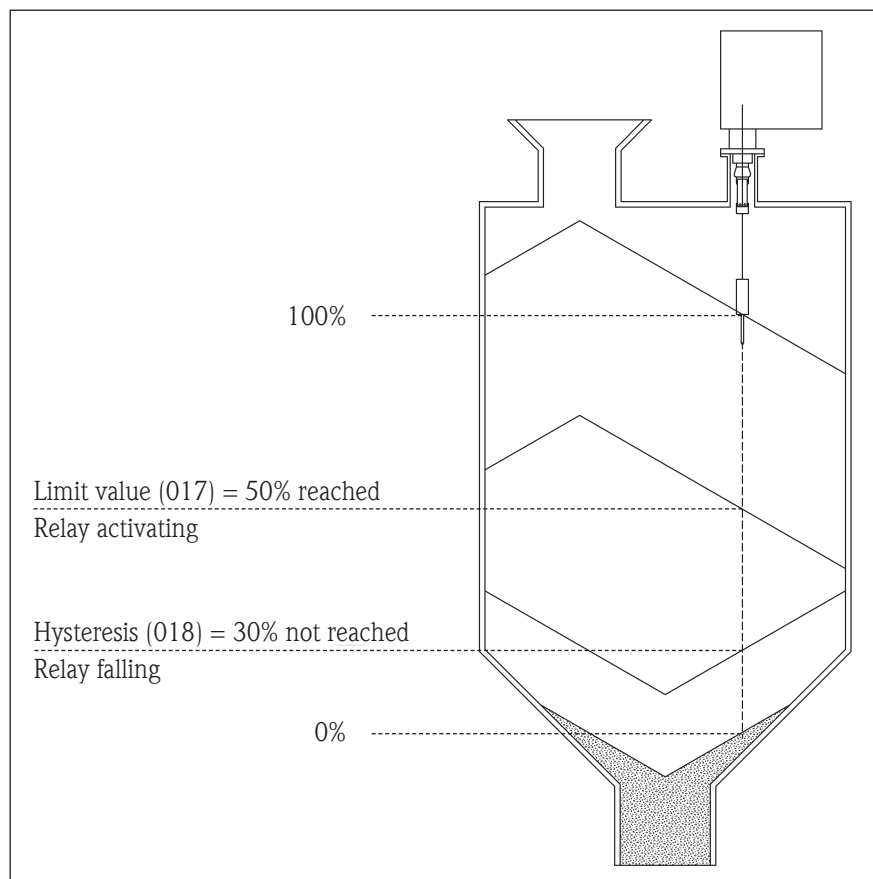

8.2.11 Reset pulse (019)

```

reset pulse     019
      300 ms
length of the
reset pulse
    
```

With this function, you determine the length of the reset pulse of the relay outputs, when e.g. "reset pulse" has been selected in function 014, in milliseconds.

Range of values: 30 ms ... 1000 ms

Default value: 300 ms

8.3 "Measurement parameters (02)" function group

8.3.1 Type of measurement (020)

```
measurement type 020
√single cycle
  Periodical
  manual
```

With this function, you select a type of measurement for the Silopilot. You will find a precise description of this function in the 8.1 "basic setup" section.

Default value: Single cycle

8.3.2 Time interval (021)

```
time interval 021
  1 min.
```

With this function, you enter a value for the time interval for the "periodical" type of measurement (see function 020). You enter the unit of this value (minutes or hours) in function 022.

Range of values: 1 ... 60 (minutes or hours)

Default value: 1



Attention!

When operating the Silopilot, please observe the minimum time (T_M) for a measurement cycle depending on the ambient temperature and measurement range.

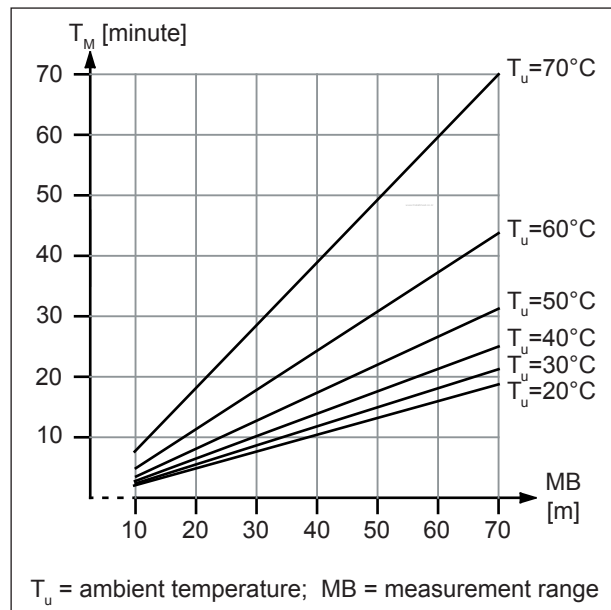

Warning!

The minimum time for a measurement cycle must be taken into account in all types of measurement (function 020). Non-observance may result in unauthorized heating and therefore malfunctions!

8.3.3 Time unit (022)

```
time unit 022
√min.
  h
```

With this function, you enter the unit of the time interval from function 021.

- **Min.:** Minute(s)
- **h:** Hour(s)

Default value: Min.

8.3.4 Normal or short (023)

```
normal or short 023
√normal
short
```

With this function, you select the operating mode for the measurement:

- **Normal:** At the start of a measurement, the Silopilot lowers the sensing weight down to the product, the sensing weight is then pulled back into the upper limit position.
- **Short:** At the start of a measurement, the Silopilot lowers the sensing weight down to product, but the sensing weight is then only raised by one meter. An input for the lock should be used since in this operating mode the sensing weight is not protected against burying. The upper limit position is approached every 20 measurement cycles.

Default value: Normal



Note!

Depending on silo height and fill level, the "short" operating mode can considerably shorten the length of a measurement cycle. Disadvantages of this operating mode:

- By selecting the appropriate settings, the user must ensure that the sensing weight is not buried.
- There is little point in using a relay output for the counter pulse since the Silopilot does not approach a defined point (and therefore no defined distance) at the end of a measurement.
- Before removing the Silopilot, e.g. for maintenance work (tape changes), the sensing weight must be moved into the upper limit position. The "manual" type of measurement should be used for this purpose.

8.3.5 Service interval (024)

```
service interval 024
45000
num. of measurements
til tape change
```

With this function, you specify the number of measurement cycles before the next maintenance (including tape changes) is undertaken. If the set value is reached, the Silopilot issues a warning. The "service interval" relay output switches. The warning and/or switched relay output can be reset by resetting the service interval counter in function 025.

Range of values: 1 ... 90000

Default value: 45000



Note!

The number of Silopilot measurements before the next round of maintenance work depends on the process environment. The user should adjust this value depending on the level of dirt and/or measuring tape condition!

8.3.6 Service interval counter (025)

```
serv.int.counter 025
5678
```

With this function, you can change the internal counter for the service interval, e.g. for resetting purposes once the service interval has been reached (see function 024).

Range of values: 0 ... 90000

8.3.7 Simulation (026)

```
simulation      026
√sim. off
  sim. level
  sim. volume
```

Simulation mode allows the user to simulate a particular measured value, e.g. in order to check downstream process control systems. The relay outputs can also be checked. During simulation, the measured value display (function 000) shows the alarm symbol. The following simulations can be selected:

- **Sim. off:** Simulation is switched off.
- **Sim. level:** A fill level can be specified in function 027. In such cases, the range of values conforms with the upper-range value entered in function 057. The value entered is shown in the measured value display. The functions of the relay outputs (e.g. the limit value) and the current output follow the simulation value.
- **Sim. volume:** A volume can be specified in function 027. In such cases, the range of values conforms with the upper-range value entered in function 057. The value entered is shown in the measured value display. The functions of the relay outputs (e.g. the limit value) and the current output follow the simulation value.
- **Sim. current :** A current value can be specified in function 027. The measured value display continues to show the last measured value. The functions of the relay outputs (e.g. the limit value) do not follow the simulation value.

Default value: Sim. off



Note!

When in simulation mode, normal measuring with the Silopilot is not possible.

- If the device was in "manual" mode before simulation was activated, the sensing weight remains in its current setting.
- If the device was in "periodical" mode before simulation was activated, this mode remains active. The last measured value is saved internally and once the simulation is ended, is shown in the measured value display.
- If the device was in "single cycle" mode before simulation was activated, this mode is no longer active. The inputs and the "Man.start" button are deactivated. A measurement which has already been started is normally ended, measured value is saved internally and once the simulation is ended, is shown in the measured value display.

8.3.8 Simulation value (027)

```
sim. value 027
 10.00 mA
```

With this function, you enter a value for the type of simulation selected in function 026.

- Range of values: 0 ... 99 m (level)
- 0 ... 22.00 mA (current)
- 0 ... 100 000 (volume)

Example of fill level simulation

Silopilot settings:

| Function | Function number | Input / value |
|--------------------|-----------------|----------------|
| Empty calibration | 001 | 50 m |
| Full calibration | 003 | 45 m |
| Relay 1 | 014 | Limit value |
| Limit value | 017 | 50% |
| Hysteresis | 018 | 10% |
| Level/ullage CU/DU | 050 | Level CU |
| Linearization | 051 | Linear |
| Customer unit | 056 | m ³ |
| Upper-range value | 057 | 10000 |

1. Simulation (026) = level
 Simulation value (027) = 8000
 → display (000) = 8000 m³
 Current output = 16.8 mA
 Relay 1 is activated

2. Simulation (026) = level
 Simulation value (027) = 2000
 → display (000) = 2000 m³
 Current output = 7.2 mA
 Relay 1 has fallen

8.4 "Current output (03)" function group

8.4.1 Current mode (030)

```
current mode      030
√standard
magnify
```

With this function, you determine the characteristics of the current output:

- **Normal:** The current output of the Silopilot delivers a current of 0/4 ... 20 mA (selectable in function 033) related to 0 ... 100% of the measurement range set (function 002 "full calibration").
- **Current magnifier:** If this option is selected, only part of the measurement range in the output current range of 0/4 ... 20 mA (selectable in function 033) is displayed (see following illustration). This range is defined by function 031 "0/4mA value" and function 042 "20mA value".

Default value: Normal

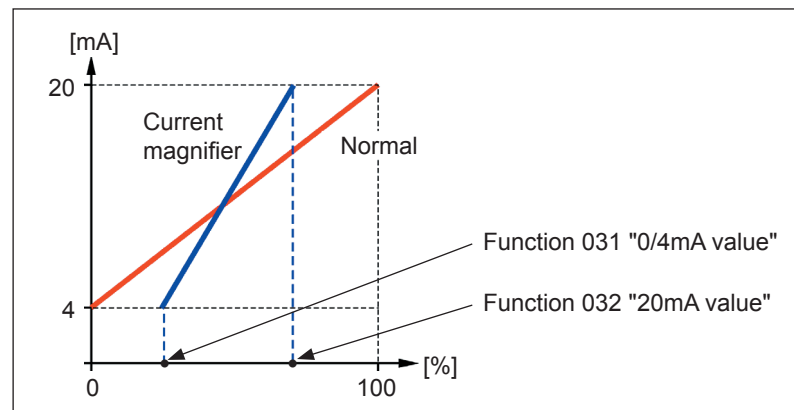

8.4.2 0/4 mA value (031)

```
0/4mA value      031
30.00 %
```

With this function, you determine the value for the lower limit of the current output (see function 030).

Range of values: Depends on distance unit or CU

8.4.3 20 mA value (032)

```
20mA value       032
70.00 %
```

With this function, you determine the value for the upper limit of the current output (see function 030).

Range of values: Depends on distance unit or CU



Attention!

When changing the upper-range value (in function 057), the 0/4 mA value or the 20 mA value must also be changed or adapted!

8.4.4 Current Range (033)

```
current range    033
√4-20mA
0-20mA
```

With this function, you select the range of the current output (030).

- **4-20mA**
- **0-20mA**

Default value: 4-20mA

8.5 "Safety settings (04)" function group

8.5.1 Output on alarm (040)

```
output on alarm 040
√MIN (0/3.6mA)
MAX (22mA)
hold
```

With this function, you determine the characteristics of the current output in the event of an error:

- **MIN (0/3.6mA):** If the Silopilot detects an error (e.g. tape tearing off), the current falls to 0 or 3.6 mA (depends on function 033).
- **MAX (22mA):** If the Silopilot detects an error, the current increases to 22 mA.
- **Hold:** If the Silopilot detects an error, the last current output is retained.
- **User-specific.:** If the Silopilot detects an error, the current set in function 041 is output.

Default value: MIN (0/3.6mA)

8.5.2 Current value (041)

```
output on alarm 041
3.60 mA
```

With this function, you determine the user-specific current value in the event of an error (see function 040).

Range of values: 0 ... 22.00 mA

Default value: 3.60 mA

8.5.3 Min. safety (042)

```
safety distance 042
1.00 m
minimum distance
to empty calibration
```

With this function, you determine the minimum distance e.g. to an outlet worm. This function prevents the measuring tape from running out into an unauthorized area of the silo or bunker (also see Basic calibration chapter 8.1).

Range of values: 0 m ... (full calibration - min. safety)
(or converted value in feet/inches)

Default value: 0 m

8.5.4 Safety distance (043)

```
security dist. 043
0.00 m
minimum distance
to empty calibration
```

A configurable safety zone is set up before the blocking distance (function 002). This zone is used to warn that if the fill level continues to rise, future measurements could be invalid since the blocking distance (and therefore also the minimum run out length of the Silopilot) could not be reached.

Range of values: 0 m ... (full calibration - min. safety)
(or converted value in feet/inches)

Default value: 0 m

8.6 "Linearization (05)" function group

8.6.1 Level/volume (050)

```
level/volume      050
√level CU
  level DU
  ullage CU
```

With this function, you determine the display value in the measured value display function (000).

- **Level CU:** Depiction of fill level in customer units. The unit can be selected or deselected in the "customer unit" function (056), and the maximum scale value in "max. scale" function (057). Linearization of the measured value is possible.
- **Level DU:** Depiction of the fill level in the "distance unit" function (083).
- **Ullage CU:** Depiction of residual volume in customers units. The unit can be selected or deselected in the "customer unit" function (056), and the maximum scale value in the "max. scale" function (057). Linearization of the measured value is possible.
- **Ullage DU:** Depiction of residual distance in "distance unit" function (083).

Default value: Level CU



Note!

The reference point for level and ullage is the "**full calibration (003)**".

Example of a volumetric measurement (without linearization, also see basic setup):

- Full calibration (003) = 20 m
- Silo volume (in measurement range selected) = 500 m³
- Current level = 4 m

1. measurement of current volume

Level/ullage (050) = Level CU
 Linearization (051) = linear,
 Customer unit (056) = m³,
 Max. scale (057) = 500

→ display (000) = 100 m³

2. measurement of residual volume

Level/ullage (050) = Ullage CU
 Linearization (051) = linear
 Customer unit (056) = m³,
 Max. scale (057) = 500

→ display (000) = 400 m³

8.6.2 Linearization (051)

```
linearization     051
√linear
  manually
  table on
```

Linearization defines the relationship between the fill level and container volume and/or product weight and permits a measurement in customers units (CU).

- **Linear:** The relationship between the fill level and container volume is linear.
- **Table On:** Activates a previously entered linearization table.
- **Delete table:** Deletes an available linearization table.
- **Manually:** Input of a linearization table.

Default value: Linear

8.6.2.1 Manual linearization

If the fill level is not proportional to the volume and/or weight within the measurement range set (**full calibration (003)**), a linearization table can be entered. The following preconditions apply:

- The maximum 32 pairs of values for level/volume and/or level/weight are known (e.g. gauging capacity by liters).
- The fill level values must be entered in ascending order (curve rises in monotone manner).
- The fill height for the first and last points of the linearization curve should correspond to the empty and full calibration.
- Linearization is undertaken in the unit of basic setup (**distance unit (083)**).

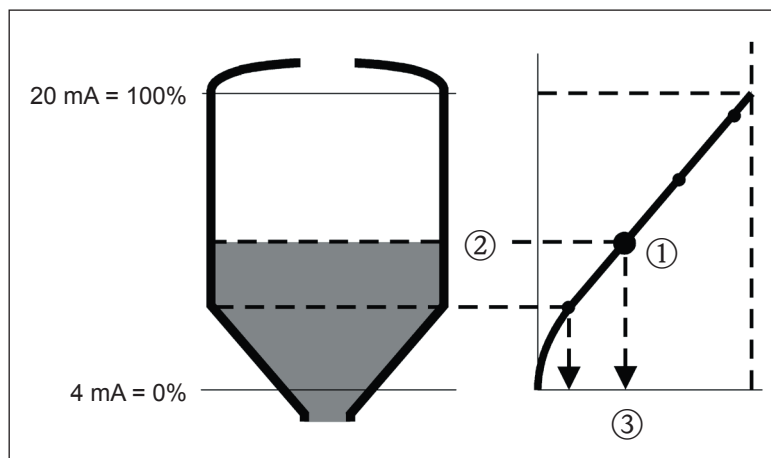

Each point ① in the linearization table is described by a pair of values:

② fill level and volume (or weight) ③.



Note!

- Before entering a linearization table, any tables present from previously must be deleted: (linearization (051) = "**clear table**").
- Once a linearization table has been entered, it must be activated: (linearization (031) = "**table on**").
- An entered linearization table can be deactivated by selecting "**linear**". This does not delete the table and it can be reactivated at any time by selecting "**table On**".

8.6.2.2 Entering a linearization table

You can enter a linearization table as follows:

```
linearization 051
√manually
  linear
  table on
```

Select manually linearization
(= entry of linearization table)



```
linearization 052
TabNo→      1
level       0.000m
volum      0.000%
```

Select table point 1
(start with 1, maximum 32)



```
linearization 053
TabNo       1
level→     0.000m
volum      0.000%
```

Enter the fill level belonging to point 1



```
linearization 054
TabNo       1
level       0.000m
volum→     0.000%
```

Enter the corresponding volume (weight)



```
next point 055
√yes
  no
```

What if another table point is to be entered?



```
linearization 052
TabNr→      2
Fülls       0.000m
Volum       0.000%
```

Select table point 2

Continue either until 32 table points have been selected or until manual entry of the linearization table is completed by selecting "next point = no".

Once the linearization table has been activated via "table on", linearization is activated.



Note!

If the customer unit (function 056) and/or upper-range value (function 057) is changed, the linearization table has to be re-entered or adjusted!

8.6.3 Customer unit (056)

```
customer unit 056
√%
kg
t
```

With this function, you can select the customer unit. The following units are available for selection:

- Percentage (%)
- Weight: **kg, t**
- Volume: **m³, ft³**
- Length: **m, ft, in**

Default value: %

8.6.4 Maximum scale (057)

```
max. scale 057
100 %
```

With this function, you can define the upper-range value (in the unit selected and the number of digits after the decimal point selected).

Range of values: 1 ... 100000

Default value: 100

8.7 "Display (06)" function group

8.7.1 Language (060)

```
language 060
√english
german
```

With this function, select the language for the display texts:

- German
- English

Default value: English

8.7.2 Back to home (061)

```
back to home 061
100 s
time until jump back
home automatically
```

With this function, you specify the time after which the display returns to the measured value display (000).

Range of values: 3 ... 9999 seconds

Default value: 100

8.7.3 Number of decimals (062)

```
no. of decimals 062
√x
x.x
x.xx
```

With this function, you select the number of digits after the decimal point for the measured value display (000) and for entry of several parameter values (e.g. limit value):

- x: No digit(s) after the decimal point
- x.x: One digit after the decimal point
- x.xx: Two digits after the decimal point
- x.xxx: Three digits after the decimal point

Default value: x.xx

8.7.4 Format display (063)

```
format display 063
√on
off
```

With this function, you activate a test for the LC display.

All points on the display are activated for around 2 seconds.

- Off: No display test
- On: Display test

Default value: Off

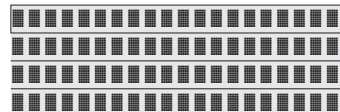

8.8 "Diagnostics (07)" function group

8.8.1 Present error (070)

```
Present error 070
simulation
activated
W621
```

The present error (e.g. "simulation activated"), its error code (e.g. 621) and the letter "W" for warning or "A" for alarm are shown in the display. If the error is a warning, only this is displayed. In the case of an alarm, this is also output via the "Alarm" relay output, provided that this has been selected.

For the depiction of all error codes, please refer to chapter 10 "Troubleshooting".

8.8.2 Previous error (071)

```
Previous error 071
minimum run down
length underflow
A440
```

The previous error, its error code and the letter "W" for warning or "A" for alarm are shown in the display.

For the depiction of all error codes, please refer to chapter 10 "Troubleshooting".

8.8.3 Clear errors (072)

```
clear errors 072
verase last
erase current
erase all
```

With this function, you can delete the errors shown:

- **keep:** Errors are not deleted.
- **erase last:** Last error is deleted.
- **erase current:** Current error is deleted.
- **erase all :** All errors are deleted.

Default value: keep

8.8.4 Reset (073)

```
reset 073
0
for reset code
see manual
```

With this function, you can reset the Silopilot. All parameters are loaded with their default values.

- Range of values:
- 333 undertakes reset
 - <>333 does not undertake reset



Note!

- At least a basic calibration must have been undertaken before the Silopilot can be reset!
- Take a note (if possible) of the parameters set so that the Silopilot function required can be re-established after the reset! You will find suitable tables for noting all settings in the appendix.

8.8.5 Unlock parameter (074)

```
unlock parameter 074
100
for reset code
see manual
```

With this function, you can lock/unlock the parameter entries. No more values can then be entered in any part of the menu (exception: release code).

- Range of values:
- <>100 locks parameter entry
 - 100 unlocks parameter entry

8.9 "System parameters (08)" function group

8.9.1 Tag number (080)

```
tag no.          080
Ratingen Silo 1
```

With this function, you can give the measuring point of the Silopilot a name of no more than 16 alpha-numerical digits.

Default value: _____

8.9.2 Protocol + software number (081)

```
Protocol+sw-no. 081
V01.01.00
```

With this function, you can display the protocol and software version of the Silopilot.

8.9.3 Serial number (082)

```
serial no.      082
1001
```

With this function, you can display the serial number of the Silopilot. You will also find the serial number on the nameplate.

8.9.4 Distance unit (083)

```
distance unit   083
√m
ft
in
```

With this function, you can enter the length unit of the Silopilot. This forms the basis for all display and entry values, with the exception of the technical unit (CU), provided that this has been selected.

- **m:** meter
- **ft:** feet
- **in:** inch

Default value: m

8.10 "Service (0D)" function group

You can find a detailed description of the "service" function group as well as a detailed overview of the function menu in the Service Manual for Silopilot M.

9 Manual mode

By selecting "manual" mode in the "measurement type (020)" function, the Silopilot can be operated using the \square and \square keys on the device. Manual mode gives the user the opportunity to move the sensing weight slowly (e.g. for a tape change).



Warning!

When in manual mode, the limit-switch and the tape-switch have no function! Users must themselves ascertain the position in which the sensing weight is currently located. In manual mode, the sensing weight can e.g. be lowered into an outlet worm (depending on the maximum tape length).



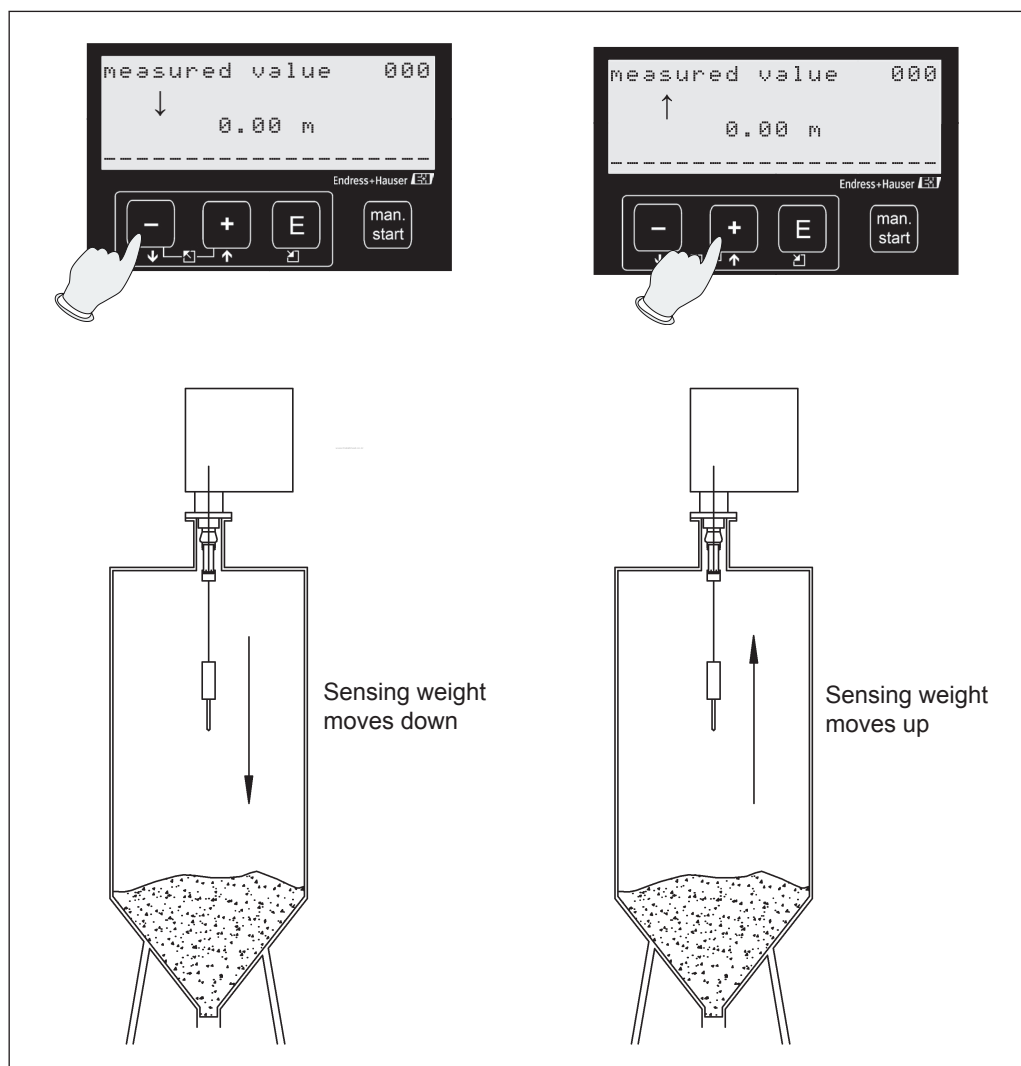

9.1 Operation

Once the "manual" mode has been selected (see chapter 8.2), the "measured value (000)" function must be selected. Manual movements can now be undertaken using the keys.



9.2 Display

If the Silopilot is in manual mode, a hand symbol appears on the display:

| Symbol | Meaning |
|---|--|
|  | - This symbol flashes when the device is in the "manual" mode without a button being pressed. |
|  | - This symbol flashes when the device is in the "manual" mode and the  button is pressed. - The sensing weight moves down. |
|  | - This symbol flashes when the device is in the "manual" mode and the  button is pressed. - The sensing weight moves up. |

In manual mode, the measured value (000) automatically shows the tape length run out. The value displayed depends on the distance unit (m, ft, in) selected in function 083 as well as the depiction of digits after the decimal point selected in function 062. Once work in manual mode has been completed, the measured value is changed back to the form of depiction originally selected (e.g. fill level in customer units).



Note!

The last valid measured value remains saved internally, it is not overwritten in manual mode. The outputs still follow this (e.g. with a 50% fill level and 4 - 20 mA output current range, 12 mA is still output for the current output).

10 Troubleshooting

10.1 Error messages

10.1.1 Current error (070)

Errors which occur during commissioning or measurement operation are displayed as follows:

- by the error symbol in the "**measured value (000)**" function
- in the "Diagnostics (07)" function group in the "**present error (070)**" function



Note!

Only the error with the highest level priority is displayed.

```
Present error      070
simulation
activated
W621
```

This display can be deleted in the "**clear errors (072)**" function.



10.1.2 Previous error (071)

The previous error is displayed in the "Diagnostics (06)" function group in the "**previous error (071)**" function.

```
Previous error    071
motor voltage
is too low
A204
```

This display can be deleted in the "**clear errors (072)**" function.

10.2 Types of errors —

| Type of error | Symbol | Meaning |
|---------------|--|---|
| Alarm (A) |  Permanent | The current output adopts a value which can be defined by the " output on alarm (040) " function: - MIN (0/3.6 mA) - MAX (22 mA) - Hold: Last value is retained - User-specific: A defined output current can be specified in the " output on alarm (041) " function. |
| Warning (W) |  Flashing | - Device continues to measure. - An error message is displayed. |

10.3 Error messages

All possible errors, their error codes and their meaning or possible forms of rectification can be seen in the following tables:

| Code | Cause | Remedy |
|------|---|--|
| A100 | Checksum error in internal program memory | <ul style="list-style-type: none"> - Reset - Avoid EMC problems - If the alarm is still present after a reset, contact service or replace the electronics |
| A101 | Checksum error in EEPROM 1 | |
| A102 | Checksum error in EEPROM 2 | |
| A103 | Initialization failed | |
| A106 | Program download error (only for service technicians) | Repeat download or restart |
| W110 | Default service parameters loaded | <ul style="list-style-type: none"> - Warning that a reset has been undertaken - Goes out automatically with next entry |
| W111 | Default user parameters loaded | |
| W112 | Default input/output configuration loaded | |
| W113 | Default table for linearization loaded | |
| A120 | Error in loading the service parameters | <ul style="list-style-type: none"> - Reset - Avoid EMC problems - If the alarm is still present after a reset, contact service or replace the electronics |
| A121 | Error when loading the user parameters | |
| A122 | Error when loading the input/output configuration | |
| A123 | Error when loading the last measured values | |
| A124 | Error when loading the linearization table | <ul style="list-style-type: none"> - Check linearization table - Re-enter linearization table if necessary |
| A130 | Process of saving the service parameters has failed | <ul style="list-style-type: none"> - Reset - Avoid EMC problems - If the alarm is still present after a reset, contact service or replace the electronics |
| A131 | Process of saving the user parameters has failed | |
| A132 | Process of saving the input/output configuration has failed | |
| A133 | Process of saving the measured values has failed | |
| A134 | Process of saving the linearization has failed | |
| A200 | Interface to motor controller defective | |
| A201 | Initialization of motor controller failed | |
| A202 | Fatal motor error | |
| A203 | Temperature switch inside motor triggered | <ul style="list-style-type: none"> - Reset - Avoid heating the Silopilot too much - If the alarm is still present after a reset, contact service or replace the electronics |

Continuation of system error messages:

| Code | Cause | Remedy |
|--------------|---|---|
| A204 | Motor voltage too low | <ul style="list-style-type: none"> - Reset - Check supply voltage (see details on Silopilot nameplate) - If the alarm is still present after a reset, contact service or replace the electronics |
| A205 | Motor current consumption is too high | <ul style="list-style-type: none"> - Reset - Avoid heating the Silopilot too much - If the alarm is still present after a reset, contact service or replace the electronics |
| A206 | Motor driver defective | <ul style="list-style-type: none"> - Reset - If the alarm is still present after a reset, contact service or replace the electronics |
| A207 | Motor voltage is too high | <ul style="list-style-type: none"> - Reset - Check supply voltage (see details on Silopilot nameplate) - If the alarm is still present after a reset, contact service or replace the electronics |
| A330 | Maximum time for a measurement exceeded | If the alarm is still present after several measurement processes, contact service |
| A340 | Sensing weight/tape is torn | <ul style="list-style-type: none"> - Check the sensing weight and measuring tape - Replace sensing weight and/or measuring tape if necessary |
| A350 | Sensing weight is buried | <ul style="list-style-type: none"> - Expose sensing weight by hand - Reset or briefly withdraw supply voltage (restart the device) |
| A430 | Tape-switch expected | Contact service or replace the tape-switch |
| A431 | Limit-switch expected | Contact service |
| A440 | Minimum move distance not reached | <ul style="list-style-type: none"> - Check mounting situation - Observe minimum sensing weight move distance of 20 cm |
| A450 | Time for counting wheel pulses exceeded | <ul style="list-style-type: none"> - Check the counting wheel - Reset |
| A460 | Slip on counting wheel | - If the alarm is still present after a several measurement processes, contact service |
| W611 | Less than 2 points entered in linearization table | <ul style="list-style-type: none"> - Check linearization table - Add missing points if needed |
| W621 | Simulation activated | Deactivate simulation in function 026 |
| A630 | Maximum move distance exceeded | <ul style="list-style-type: none"> - Check the tape-switch - Check the installation situation - Use device with larger measurement range |
| A650 W651 | Safety distance under-run | <ul style="list-style-type: none"> - Check the installation situation - Check the programming |
| A660 | Security distance under-run | |
| W681 | Measurement range exceeded | |
| W690 | Linearization incomplete or unusable | <ul style="list-style-type: none"> - Check linearization table - Add missing points if needed |
| W700 | Tape must be changed | <ul style="list-style-type: none"> - Check measuring tape, replace if necessary - Reset service interval counter |

11 Maintenance

11.1 External cleaning

When externally cleaning the Silopilot, ensure that the cleaning agent used does not attack the housing surface and seals.

11.2 Cleaning dirty compartment

The cleaning periods depend on the properties of the bulk solid. If a lot of dust has accumulated, we would recommend blowing in small amounts of clean compressed air via the mounting flange (see chapter 4 "Installation").

11.3 Wiper check

The two tape-wipers in the wiper are worn to a greater or lesser extent depending on the abrasive nature of the product and then no longer sufficiently clean the measuring tape.

To check the wiper, you have to remove the Silopilot. To do so, please note chapter 4 "Installation". The following points should be checked:

- Check whether the taper and the end guide are being dissected by the measuring tape. If there are deep gashes, there is a risk of the measuring tape jamming. Replace the end guide if necessary.
- Check whether both tape-wiper scrapers are securely in contact with the measuring tape. Also replace the tape-wiper scrapers if worn.
- Check whether the bellows are still in perfect condition. Replace if damaged.

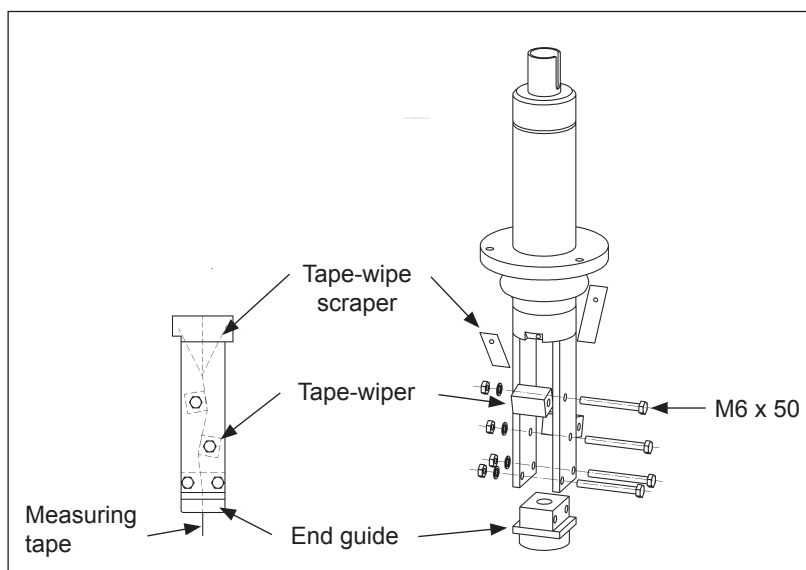

Note!

Please refer to chapter 12 "Repair" for details of how to dismantle the Silopilot.

11.4 Measuring tape check

On the Silopilot, it is the measuring tape which is subject to the greatest mechanical load. It should therefore be checked as follows at regular intervals:

- If the visible part (Silopilot top position) of the measuring tape is damaged, uncoil a section (measuring type "manual" (020)) until it looks perfect. Cut off the damaged part and re-mount the sensing weight.

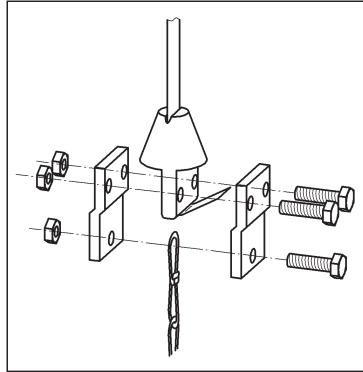

Attention!

Do not cut off too much. Note the original tape length and the measurement range required (container height).

- If the measuring tape is damaged on a longer part, replace the entire measuring tape. Tape spools of standard lengths can be supplied for this purpose.



Note!

Please refer to chapter 12 "Repair" for details of how to dismantle the Silopilot.

11.5 Dirty compartment check

Also check the dirty compartment at regular intervals as follows:

- If the tape spool is severely attacked or damaged, replace it. Reels with standard lengths of measuring tape wound on can be supplied for this purpose.
- If the counting wheel is very sluggish to turn when the measuring tape is not loaded or is damaged, replace it.
- If the metal parts in the dirty compartment (tape guide, guide plate) are severely attacked or damaged, replace them. An appropriate repair kit can be supplied for this purpose.
- If the cover seal is severely attacked or damaged, replace it.



Note!

Please refer to chapter 12 "Repair" for details of how to dismantle the Silopilot.

12 Repair

The Endress+Hauser repair concept ensures that the measuring devices have a modular structure and that repairs can be undertaken by the customer. Spare parts are combined in useful kits and are accompanied by the associated replacement instructions.

All the spare part kits and their order numbers are listed in the spare parts section. These can be ordered from Endress+Hauser for repairs to the Silopilot M. For more information on service and spare parts, please contact the Endress+Hauser service department.

12.1 Repairing Ex-certified devices

When repairing Ex-certified devices, the following must also be noted:

- Repairs to Ex-certified devices may only be undertaken by the Endress+Hauser service team.
- When replacing spare parts, only genuine parts from Endress+Hauser may be used.
- When ordering spare parts, please note the device designation on the nameplate. Parts may only be replaced with the same parts.
- Conversion of a certified device in a variant with different certification may only be undertaken by the Endress+Hauser service team.

12.2 Replacing components

Once a complete Silopilot M or the electronic module has been replaced, basic calibration must be undertaken again. All parameters also have to be re-entered. We would therefore recommend the following procedure:

- Note down all settings (including the values of any linearization tables entered)!
Tables appropriate for this purpose can be found in the appendix.
- After replacement, transfer all the settings noted and if necessary also the values from a linearization table.

12.2.1 Tape change

When changing the tape or the tape spool, proceed as follows:

1. Move the sensing weight down a little (at least 5 cm) in the "manual" mode (020) so that the measuring tape is relieved.



Note!

When using larger sensing weights (e.g. cage weight), the weight must be lowered to an appropriate hatch (see chapter 4 "Installation").

2. Switch off supply voltage:
 - Move mains switch to "O" (Off) if the sensing weight is easily accessible.
 - Disconnect the mains cable if the Silopilot needs to be removed.
3. Remove or expose the Silopilot until the wiper and sensing weight are accessible.
4. Remove the tape border from the measuring tape (see chapter 11.4).
5. Unfasten the tape spool's locking screw. To simplify the process of changing the tape, we recommend removing the counting wheel and tape guide.
6. Screw the two M6 screws (at least 50 mm, DIN 933) evenly into the relevant reel holes. The tape spool is thereby pulled off the drive shaft. Alternatively, an appropriate extraction tool is provided as a spare part.

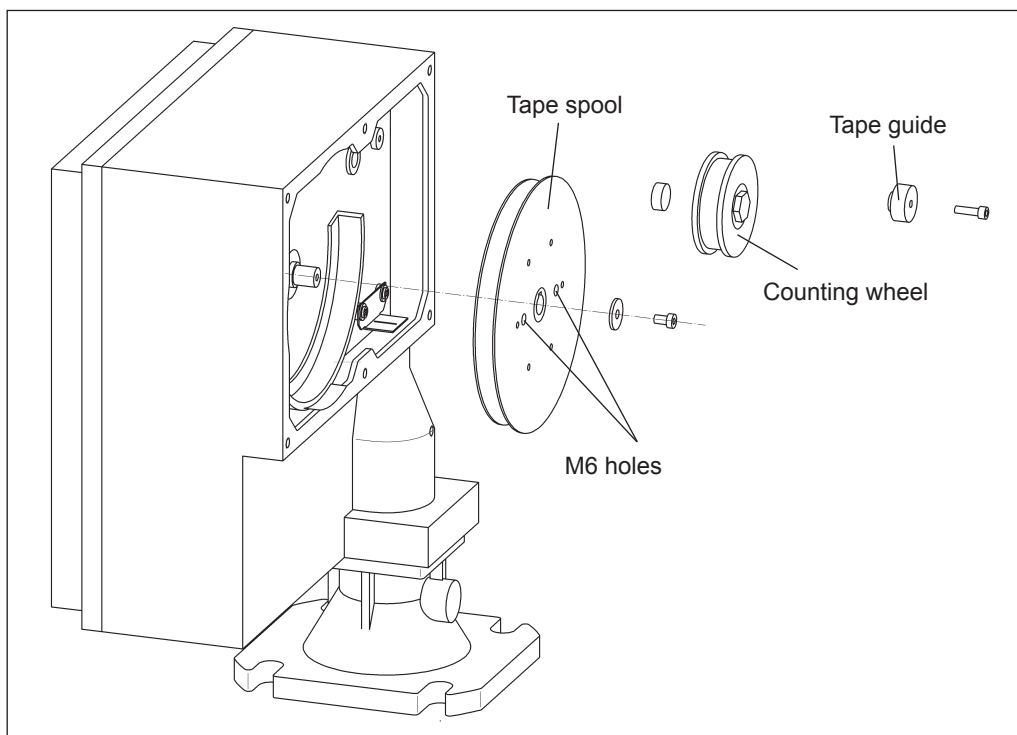

7. Carefully remove the tape spool and unwound part of the measuring tapes from the device.
8. A new tape spool is then installed in reverse order.

12.2.2 Replacing the wiper

To replace the wiper, proceed as follows:

1. Move the sensing weight down a little (at least 5 cm) in the "manual" mode (020) so that the measuring tape is relieved.



Note!

When using larger sensing weights (e.g. cage weight), the weight must be lowered to an appropriate hatch (see chapter 4 "Installation").

2. Disconnect the mains cable.
3. Remove or expose the Silopilot until the wiper and sensing weight are accessible.
4. Remove the tape border (and therefore also the sensing weight) from the measuring tape.
5. Unfasten the three M6 wiper screws. You can now take out the wiper.

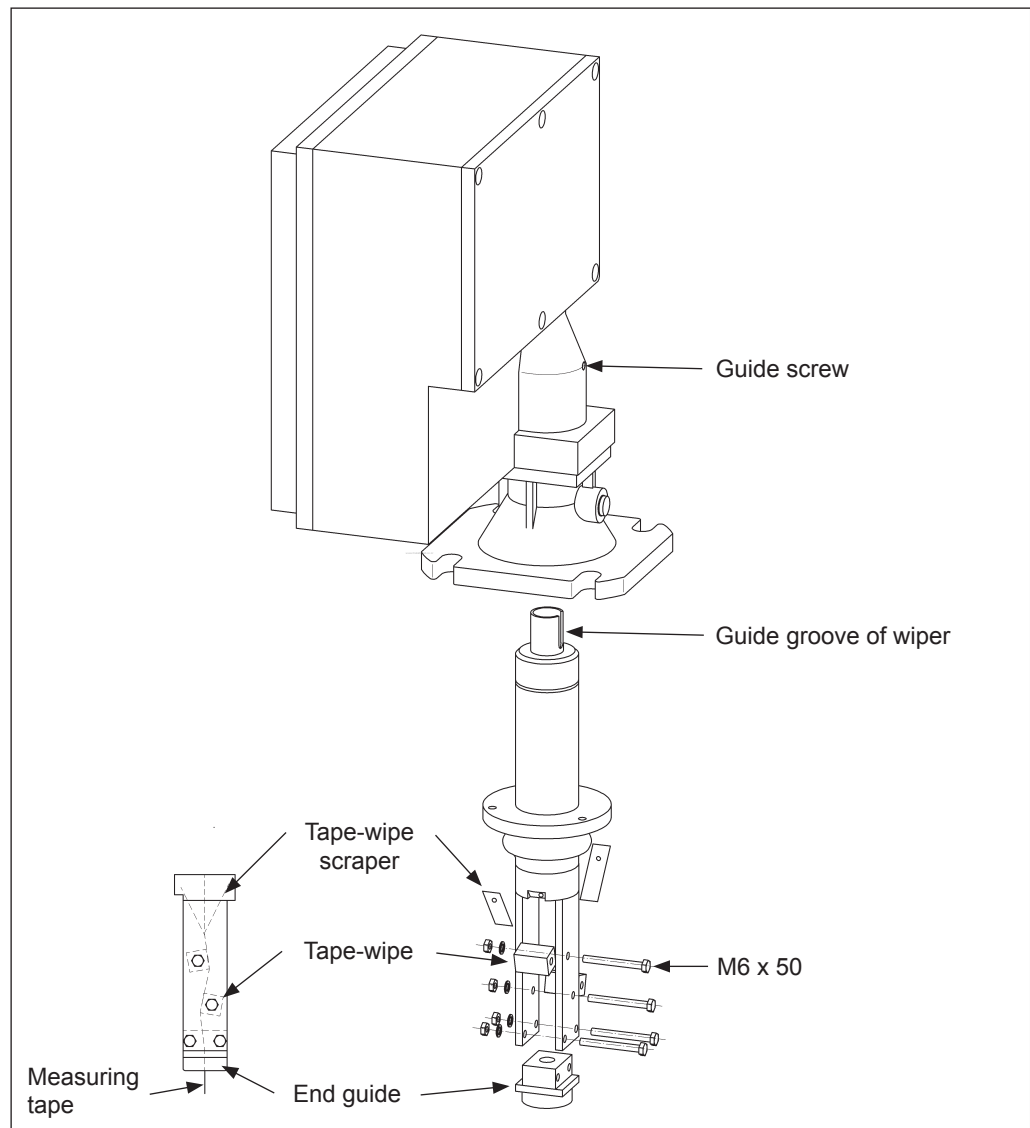

Note!

When dismantling or installing, ensure that the measuring tape is positioned correctly in the wiper. The measuring tape must not be turned in the dirty compartment. The dirty compartment cover should be opened during installation for this purpose.

6. A new wiper is then installed in reverse order. While assembling, you must ensure that the guide groove on the wiper is positioned correctly in relation to the guide screw on the Silopilot housing.

12.2.3 Replacing the drive unit

To replace the drive unit, proceed as follows:

1. Move the sensing weight down a little in the "manual" mode (020) so that the measuring tape and therefore the drive shaft are relieved. Then fix the sensing weight or measuring tape in place.
2. Switch off supply voltage:
 - Move mains switch to "O" (Off) if the sensing weight is easily accessible.
 - Disconnect the mains cable if the Silopilot needs to be removed.



Warning!

The DC link of the FMM50 remains a hazardous voltage level for a minimum of 20 minutes after disconnecting the supply voltage. Therefore always wait for 20 minutes after disconnecting the supply voltage before removing the cover!

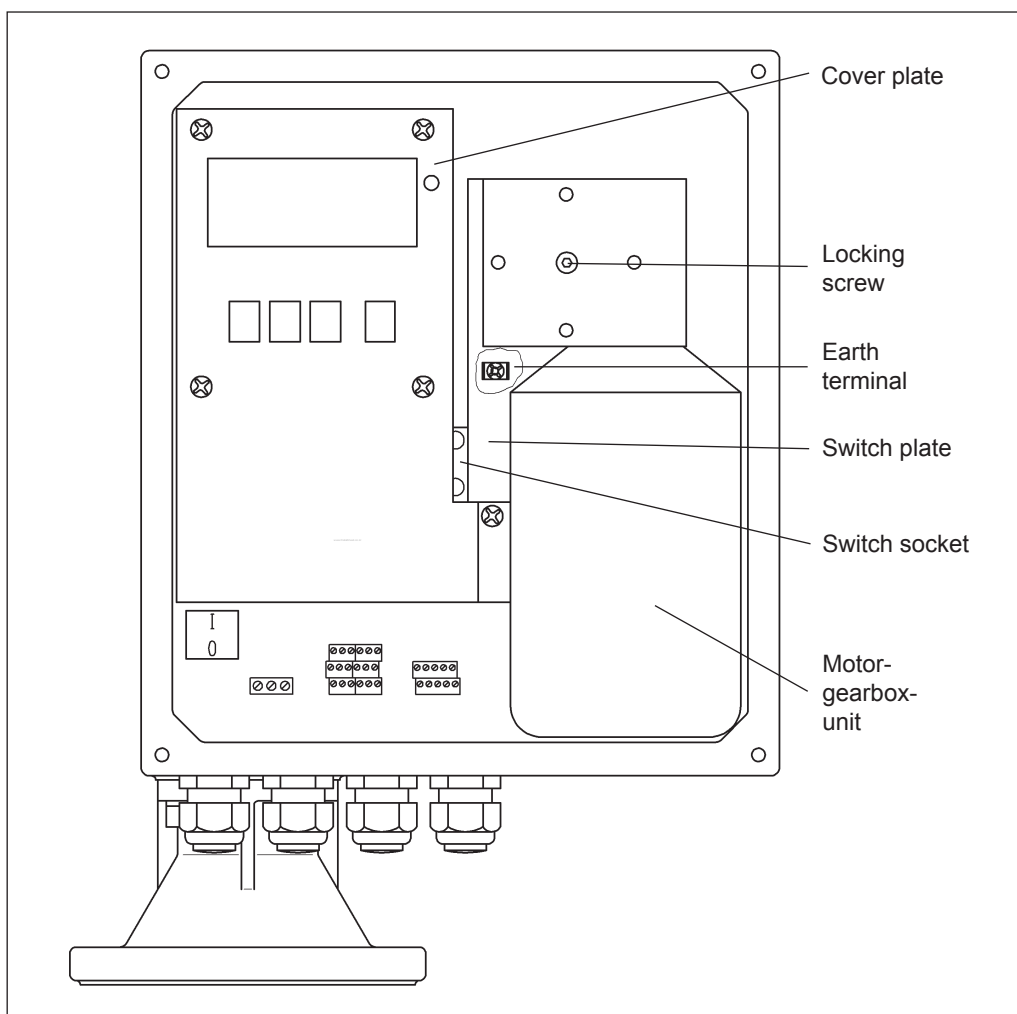

3. Loosen the 5 screws of the cover plate and take off the cover.
4. The plug for the motor connector cable can be seen at the top right of the electronics, disconnect the plug.
5. Loosen the locking screw on the drive shaft, carefully pull the motor-gearbox-unit and the switch plate linked to it out around 10 cm. An appropriate extraction tool is provided as a spare part.
6. Now disconnect the visible earthing line from the earthing terminal and you can now fully remove the drive unit.

7. A new drive unit is fitted in reverse order. Please note the following points:
 - Do not forget to reconnect the earthing cable.
 - Use a suitable tool to force the spring in the switch socket back so that you can insert the switch plate.
 - Carefully guide in the switch plate ensuring that the switch is not damaged.



Note!

Detailed replacement instructions are provided with every new drive unit!

12.2.4 Replacing the electronic unit

The electronic unit should only be replaced by a specialist. A precise description of replacement process is enclosed with every new piece of electronics. A precise description of the process is not therefore given at this point.

The following points should be noted during replacement:

- The Silopilot's electronics retain a deadly level of voltage for several minutes after the supply voltage is switched off. Always therefore wait 20 minutes, before loosening the cover plate and undertaking work on the electronics!
- When working with electronic components, ensure that you have sufficient ESD protection (protection against electrostatic discharge).
- Only use the electronics permitted for the device type when replacing parts. Using incorrect electronics may result in the device being destroyed or leads to the loss of the Ex-certification.

Once an electronic unit has been replaced, basic setup must be undertaken again. All parameters also have to be re-entered. We would therefore recommend the following procedure:

- Note down all settings (including the values of any linearization tables entered)! Tables appropriate for this purpose can be found in the appendix.
- After replacement, transfer all the settings noted and if necessary the values from a linearization table.

12.3 Spare parts



Note!

Please refer to the instruction leaflet supplied or these Operating Instructions for installation instructions.

12.3.1 Electronics

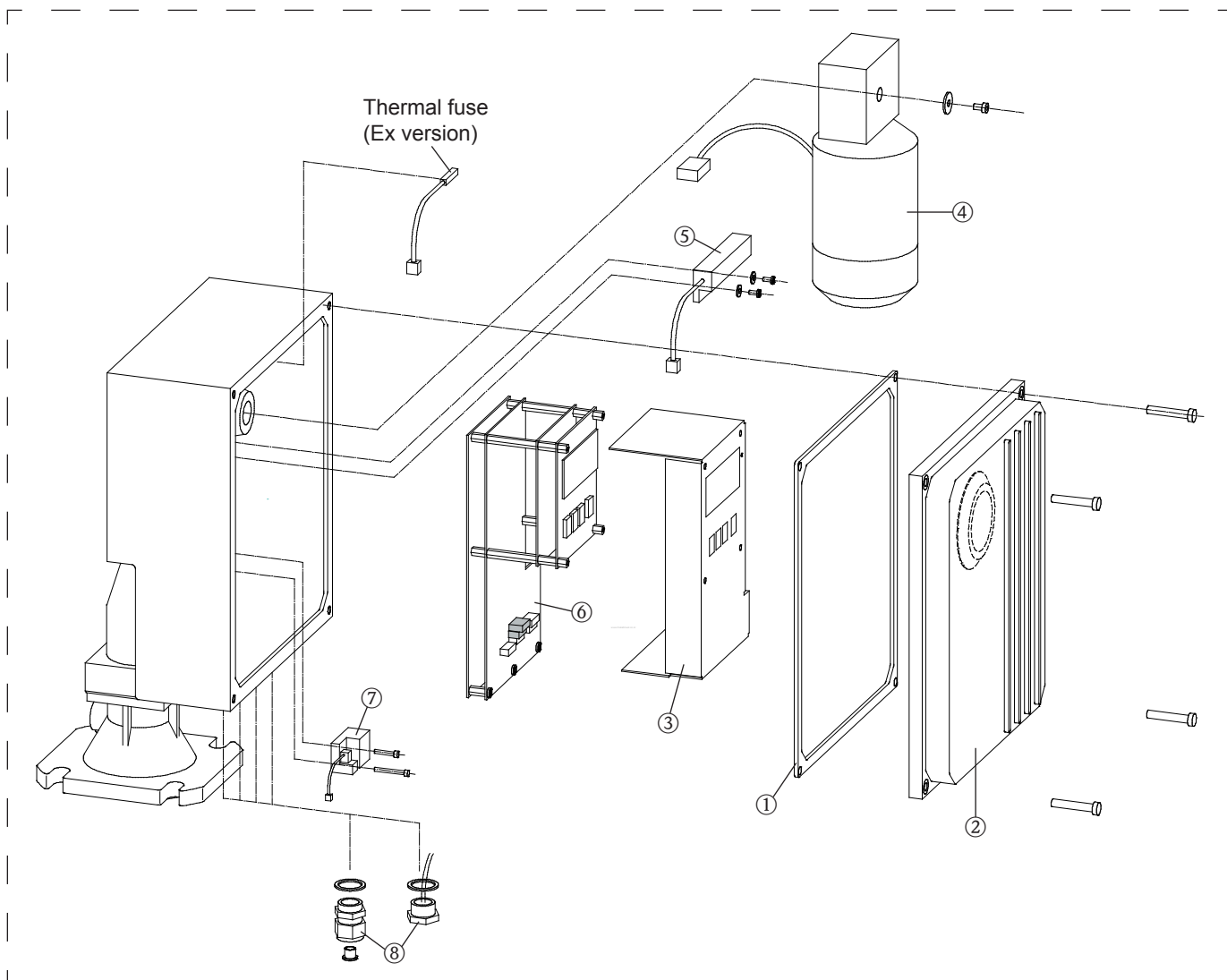

1 Cover seal for electronics compartment

- 52028104 Seal, non-Ex version
- 52028105 Seal, Ex version

2 Housing cover (incl. cover seal item 1)

- 52028136 Housing cover, not coated, non-Ex version, no sight glass
- 52028137 Housing cover, coated, non-Ex version, no sight glass
- 52028138 Housing cover, not coated, Ex version, no sight glass
- 52028139 Housing cover, coated, Ex version, no sight glass
- 52028140 Housing cover, not coated, non-Ex version, with sight glass
- 52028141 Housing cover, coated, non-Ex version, with sight glass

3 Electronic cover

- 52028155 Cover, steel plate with inscription

4 Motor-gearbox-unit

- 52028106 incl. connection and potential matching line, 230 VAC, 500 N
- 52028107 incl. connection and potential matching line, 230 VAC, 200 N
- 52028108 incl. connection and potential matching line, 115 VAC, 500 N
- 52028109 incl. connection and potential matching line, 115 VAC, 200 N

5 Device heating

- 52028177 Device heating, 115/230 VAC

6 Electronic unit, preassembled on mounting plate

- 52028120 230 VAC, 2 relay, not an Ex version, without heating connection
- 52028121 230 VAC, 6 relay, not an Ex version, without heating connection
- 52028122 230 VAC, 2 relay, Ex version, without heating connection
- 52028123 230 VAC, 6 relay, Ex version, without heating connection
- 52028124 115 VAC, 2 relay, not an Ex version, without heating connection
- 52028125 115 VAC, 6 relay, not an Ex version, without heating connection
- 52028126 115 VAC, 2 relay, Ex version, without heating connection
- 52028127 115 VAC, 6 relay, Ex version, without heating connection
- 52028128 230 VAC, 2 relay, not an Ex version, with heating connection
- 52028129 230 VAC, 6 relay, not an Ex version, with heating connection
- 52028130 230 VAC, 2 relay, Ex version, with heating connection
- 52028131 230 VAC, 6 relay, Ex version, with heating connection
- 52028132 115 VAC, 2 relay, not an Ex version, with heating connection
- 52028133 115 VAC, 6 relay, not an Ex version, with heating connection
- 52028134 115 VAC, 2 relay, Ex version, with heating connection
- 52028135 115 VAC, 6 relay, Ex version, with heating connection

7 Tape-switch

- 52028117 Tape-switch, mounting material

8 Cable glands or external start button

- 52028118 Cable gland, 4 parts, with Ex certification
- 52028119 Cable gland, 4 parts, without Ex certification
- 52028178 Start-button, external, stainless steel version

12.3.2 Mechanics

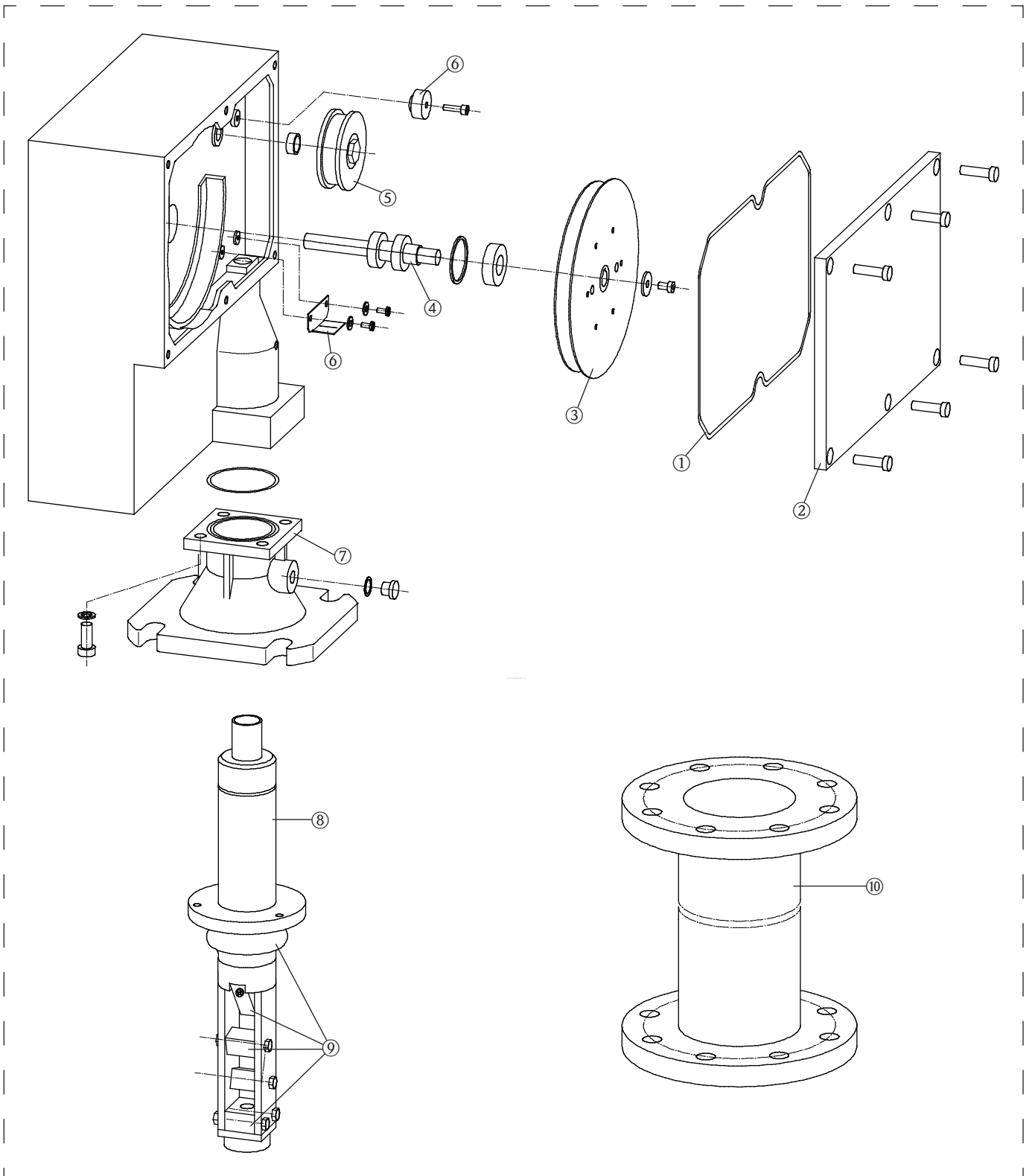

- 1 Cover seal for dirty compartment**
52028116 Seal
- 2 Housing cover (incl. cover seal item 1)**
52028142 Housing cover, not coated
52028143 Housing cover, coated

- 3 Tape spool**
52028111 Tape spool with measuring tape, 25 m
52028112 Tape spool with measuring tape, 35 m
52028113 Tape spool with measuring tape, 50 m
52028114 Tape spool with measuring tape, 70 m
- 4 Drive shaft, complete**
52028102 drive shaft incl. ball bearing, shaft seal and mounting material
- 5 Counting wheel, complete**
52028103 Counting wheel, fully mounted
- 6 Tape guide kit**
52028115 Tape guide, guide plate, mounting material
- 7 Process adapter**
52028146 Process adapter, not coated, incl. seal and mounting material
52028147 Process adapter, coated, incl. seal and mounting material
- 8 Wiper, complete**
52028068 Wiper, 230 mm, aluminum/steel, process temperature of up to +70°C
52028069 Wiper, 230 mm, stainless steel, process temperature of up to +70°C
52028070 Wiper, 230 mm, aluminum/steel, process temperature of up to +150°C
52028071 Wiper, 230 mm, stainless steel, process temperature of up to +150°C
52028072 Wiper, 500 mm, aluminum/steel, process temperature of up to +70°C
52028073 Wiper, 500 mm, stainless steel, process temperature of up to +70°C
52028074 Wiper, 500 mm, aluminum/steel, process temperature of up to +150°C
52028075 Wiper, 500 mm, stainless steel, process temperature of up to +150°C
52028076 Wiper, 1000 mm, aluminum/steel, process temperature of up to +70°C
52028077 Wiper, 1000 mm, stainless steel, process temperature of up to +70°C
52028078 Wiper, 1000 mm, aluminum/steel, process temperature of up to +150°C*
52028079 Wiper, 1000 mm, stainless steel, process temperature of up to +150°C*
*or +230°C when using the process adapter extension item 10
- 9 Spare parts kit for wiper**
52028080 Start piece, wiper plates, wiper parts, bellows, mounting material, process temperature of up to +70°C
52028081 Start piece, wiper plates, wiper parts, bellows, mounting material, process temperature of up to +150°C/+230°C
- 10 Process adapter extension**
52028082 Process adapter extension, steel
52028083 Process adapter extension, stainless steel

12.3.3 Sensing weights

For a description of the sensing weights and their possible applications, please refer to chapter 3 "Sensing weights".

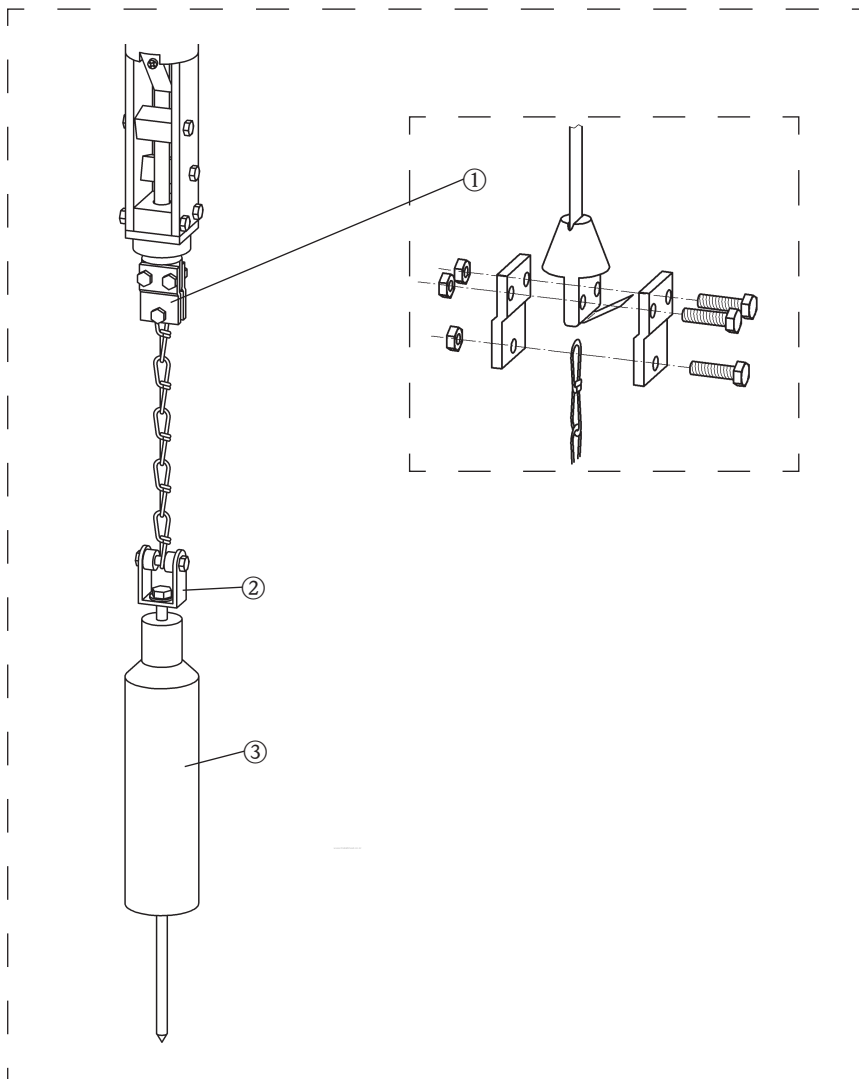

1 Sensing weight mounting, complete

52028088 Tape border, rotating bush, chain, mounting material, steel

52028089 Tape border, rotating bush, chain, mounting material, stainless steel

2 Rotating bush, complete

52028100 Rotating bush, mounting material, steel

52028101 Rotating bush, mounting material, stainless steel

3 Sensing weight, incl. rotating bush item 2

52028090 Steel

52028091 Stainless steel

52028092 Steel + umbrella

52028093 Stainless steel + umbrella

52028094 Medium bag

52028095 Steel cage

52028096 Stainless steel cage

52028097 Steel bell

52028098 Stainless steel bell

52028099 Float, PVC

12.4 Returns

The following measures must be taken before returning a measuring device to Endress+Hauser, e.g. for repair:

- Remove all residue from measuring materials which may be stuck onto the device. Pay particular attention to seal grooves and scoring in which residue from measuring materials may stick. This is of particular importance if the measuring material poses a risk to health, e.g. is flammable, poisonous, corrosive, carcinogenic etc.
- Always enclose a fully completed "**Declaration on contamination**" with the device (a template of this declaration can be found in the appendix). Endress+Hauser can only check or repair any devices returned if this is done.

Also specify:

- The chemical and physical characteristics of the measuring material
- A description of the application
- A description of the error which has occurred (if necessary, specify the error code)
- Operating period of the device

13 Accessories

13.1 Protective hood

A protective hood is available for outdoor installation of the Silopilot:

- Order no.: 52027964
- Material: stainless steel
- Weight: 7.5 kg
- The delivery includes suitable mounting screws.

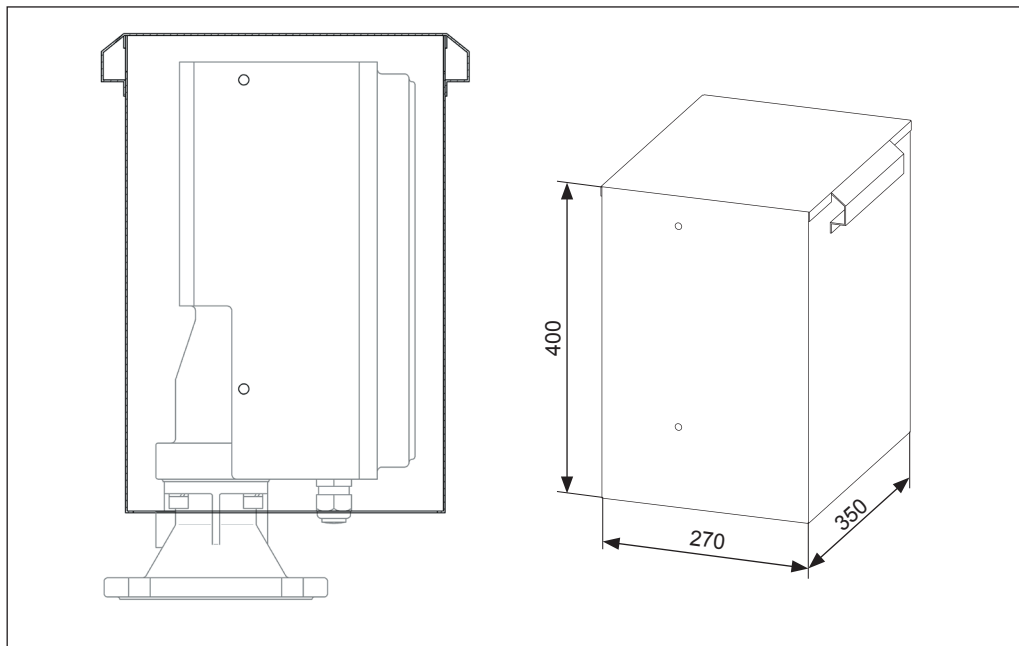

Note!

You will need a free height of at least 400 mm above the Silopilot for installing or dismantling the protective hood.

14 Technical data

14.1 Input values

| | |
|-----------------------|--|
| Measurement parameter | <p>The distance between Silopilot (device flange) and product surface is measured.</p> <p>The Silopilot can calculate the following values from this:</p> <ul style="list-style-type: none"> ■ Fill level in optional units ■ Volume in optional units, when using the linearization function even if there is a non-linear relationship between fill level and volume |
| Measurement range | <p>The maximum measurement range is calculated from the type code:</p> <ul style="list-style-type: none"> ■ Silopilot M FMM50 - ***1*: 25 m ■ Silopilot M FMM50 - ***2*: 35 m ■ Silopilot M FMM50 - ***3*: 50 m ■ Silopilot M FMM50 - ***4*: 70 m |
| Blocking distance | <p>The blocking distance is calculated from the length of the mechanism consisting of wiper, sensing weight and chain. In the 230 mm version, the wiper is 800 mm.</p> |

14.2 Output values

| | |
|----------------|--|
| Output signal | <ul style="list-style-type: none"> ■ 0/4 - 20 mA current output <ul style="list-style-type: none"> - Active - Max. load: 600 Ω ■ 2 relay outputs (max. 6 relay) <ul style="list-style-type: none"> - Contact load bearing capacity: 250 VAC, 6 A - Contact material: silver-cadmium-oxide, with gold flashings |
| Failure signal | <ul style="list-style-type: none"> ■ Error symbol, error code and description in plain text on the on-site display ■ Current output, can be configured: <ul style="list-style-type: none"> - MIN (0/3.6 mA) - MAX (22 mA) - Last value is retained - Optional value (0 ... 22 mA) is output ■ Relay outputs (alarm function) |

14.3 Accuracy

| | |
|-------------------|--|
| Measurement error | <ul style="list-style-type: none"> ■ ± 5 cm (independent of measurement range selected) |
|-------------------|--|

14.4 Activation period

Minimum time T_M for one measurement cycle

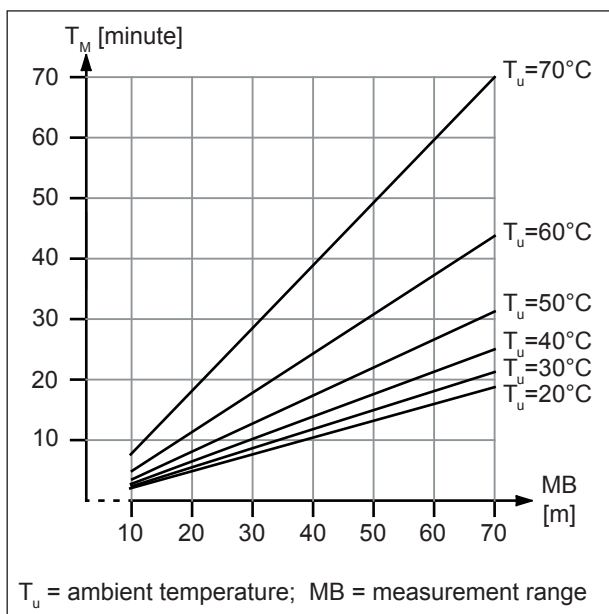

Tape running speed

- minimum 0.21 m/s
- maximum 0.35 m/s

14.5 Power supply

Supply voltage

- Silopilot M FMM50 - *****1*: 180 - 253 VAC, 50/60 Hz
- Silopilot M FMM50 - *****2*: 90 - 127 VAC, 50/60 Hz

Power consumption

- 230 VA (without device heating)
- 250 VA (with integrated device heating)

Cable entry

- M25 x 1.5
- Cable gland:
 - Material: polyamide
 - Color: gray (or black for Ex version)

14.6 Environmental conditions

| | |
|---|--|
| Ambient temperature | <ul style="list-style-type: none">■ Silopilot M FMM50 - *****A*: -20°C ... +70°C■ Silopilot M FMM50 - *****B*:<ul style="list-style-type: none">- Non-hazardous area: -40°C ... +70°C- Hazardous area: -35°C ... +70°C <p>When operating outdoors with high levels of direct sunlight, the protective hood (available as an accessory) should be used.</p> |
| Storage temperature | -40°C ... +80°C |
| Type of protection | <ul style="list-style-type: none">■ With closed housing: IP 67■ With closed housing and when using the external start button: IP 65■ With open housing: IP 20 |
| Electromagnetic version compatibility (EMC) | <ul style="list-style-type: none">■ Interference emission in accordance with EN 61326, class B operating equipment■ Interference immunity in accordance with EN 61326, Appendix A (industrial sector)■ Normal installation cable is sufficient for the wiring. |

14.7 Process conditions

| | |
|---------------------|--|
| Process temperature | <ul style="list-style-type: none">■ Silopilot M FMM50 - *****1*: -20°C ... +70°C■ Silopilot M FMM50 - *****2*: -20°C ... +150°C (non-hazardous area)■ Silopilot M FMM50 - *****3*: -20°C ... +230°C (non-hazardous area) |
| Process pressure | <ul style="list-style-type: none">■ Silopilot M FMM50 - *****1*: 0.8 ... 1.1 bar absolute■ Silopilot M FMM50 - *****2*: 0.8 ... 3.0 bar absolute (non-hazardous area) |

15 Appendix

15.1 Basic settings

| Empty calibration (001) | Block distance (002) | Full calibration (003) |
|--|-------------------------|--|
| | | |
| Default value: length of measuring tape | Default value: 0.8 m | Default: Empty calibration - 0.8 m |

15.2 Output settings

| Relay 1 (014) | Relay 2 (01A) | Relay 3 (01B) | Relay 4 (01C) |
|-------------------------|------------------------------|-----------------------|-----------------------|
| | | | |
| Default: Alarm | Default: Service interval | Default: Measuring | Default: Threshold |
| Relay 5 (01D) | Relay 6 (01E) | Pulse weight (015) | Pulse length (016) |
| | | | |
| Default: Reset pulse | Default: Band return | Default: 1 | Default: 50 ms |
| Limit value (017) | Hysteresis (018) | Reset pulse (019) | |
| | | | |
| Default: 60 % | Default: 3 % | Default: 300 ms | |

15.3 Input settings

| Input 1 (010) | Pol. Input 1 (011) | Input 2 (012) | Pol. Input 2 (013) |
|-------------------------|-----------------------------------|-------------------------|-----------------------------------|
| | | | |
| Default: No function | Default: Normally open contact | Default: No function | Default: Normally open contact |

15.4 Measurement parameter settings

| Measurement type (020) | Time interval (021) | Time unit (022) | Normal or short (023) |
|---------------------------------|-------------------------|-----------------|-----------------------|
| | | | |
| Default: Individual measurement | Default: 1 | Default: Min | Default: Normal |
| Service interval (024) | Simulation (026) | | |
| | | | |
| Default: 45000 | Default value: Sim. off | | |

15.5 Current output settings

| Current off mode (030) | 0/4 mA value (031) | 20 mA value (032) | Current range (033) |
|------------------------|--------------------|-------------------|---------------------|
| | | | |
| Default: Normal | Default: — | Default: — | Default: 4-20mA |

15.6 Safety settings

| Output on alarm (040) | Output on alarm (041) | Safety distance (042) | Security distance (043) |
|-----------------------|-----------------------|-----------------------|-------------------------|
| | | | |
| Default: MIN(0/3.6mA) | Default: 3.6mA | Default value: 0.00 m | Default value: 0.00 m |

15.7 Linearization settings

| Level/volume (050) | Linearization (051) | Customer unit (056) | Maximum scale (057) |
|----------------------|--------------------------|---------------------|---------------------|
| | | | |
| Default: Level CU | Default value: linear | Default: % | Default: 100 |

15.8 Linearization table

| | | | | | | | | |
|-------------------|-----------|-----------|-----------|-----------|-----------|-----------|-----------|-----------|
| Tab.no. | 1 | 2 | 3 | 4 | 5 | 6 | 7 | 8 |
| Fill level | | | | | | | | |
| Volume | | | | | | | | |
| Tab.no. | 9 | 10 | 11 | 12 | 13 | 14 | 15 | 16 |
| Fill level | | | | | | | | |
| Volume | | | | | | | | |
| Tab.no. | 17 | 18 | 19 | 20 | 21 | 22 | 23 | 24 |
| Fill level | | | | | | | | |
| Volume | | | | | | | | |
| Tab.no. | 25 | 26 | 27 | 28 | 29 | 30 | 31 | 32 |
| Fill level | | | | | | | | |
| Volume | | | | | | | | |

15.9 Display settings

| Language (060) | Back to home (061) | No. of decimals (062) |
|---------------------|-----------------------|--------------------------|
| | | |
| Default: English | Default: 100s | Default: x.xx |

15.10 System settings

| Tag number (080) | Distance unit (083) |
|---------------------|------------------------|
| | |
| Default: ----- | Default: m |

15.11 Explanation on contamination



Declaration of Contamination *Erklärung zur Kontamination*

Because of legal regulations and for the safety of our employees and operating equipment, we need the "declaration of contamination", with your signature, before your order can be handled. Please make absolutely sure to include it with the shipping documents, or - even better - attach it to the outside of the packaging.

Aufgrund der gesetzlichen Vorschriften und zum Schutz unserer Mitarbeiter und Betriebseinrichtungen, benötigen wir die unterschriebene "Erklärung zur Kontamination", bevor Ihr Auftrag bearbeitet werden kann. Legen Sie diese unbedingt den Versandpapieren bei oder bringen Sie sie idealerweise außen an der Verpackung an.

Type of instrument / sensor

Geräte-/Sensortyp _____

Serial number

Seriennummer _____

Process data / Prozessdaten

Temperature / Temperatur _____ [°C] Pressure / Druck _____ [Pa]

Conductivity / Leitfähigkeit _____ [S] Viscosity / Viskosität _____ [mm²/s]

Medium and warnings

Warnhinweise zum Medium



| | Medium /concentration <i>Medium /Konzentration</i> | Identification CAS No. | flammable <i>entzündlich</i> | toxic <i>giftig</i> | corrosive <i>ätzend</i> | harmful/ irritant <i>gesundheitsschädlich/ reizend</i> | other * <i>sonstiges*</i> | harmless <i>unbedenklich</i> |
|---|---|---------------------------|---------------------------------|------------------------|----------------------------|--|------------------------------|---------------------------------|
| Process medium <i>Medium im Prozess</i> | | | | | | | | |
| Medium for process cleaning <i>Medium zur Prozessreinigung</i> | | | | | | | | |
| Returned part cleaned with <i>Medium zur Endreinigung</i> | | | | | | | | |

* explosive; oxidising; dangerous for the environment; biological risk; radioactive

* *explosiv; brandfördernd; umweltgefährlich; biogefährlich; radioaktiv*

Please tick should one of the above be applicable, include security sheet and, if necessary, special handling instructions.

Zutreffendes ankreuzen; trifft einer der Warnhinweise zu, Sicherheitsdatenblatt und ggf. spezielle Handhabungsvorschriften beilegen.

Reason for return / Grund zur Rücksendung _____

Company data / Angaben zum Absender

| | |
|-------------------------|---|
| Company / Firma _____ | Contact person / Ansprechpartner _____ |
| _____ | Department / Abteilung _____ |
| Address / Adresse _____ | Phone number/ Telefon _____ |
| _____ | Fax / E-Mail _____ |
| _____ | Your order No. / Ihre Auftragsnr. _____ |

We hereby certify that the returned parts have been carefully cleaned. To the best of our knowledge they are free from any residues in dangerous quantities.

Hiermit bestätigen wir, dass die zurückgesandten Teile sorgfältig gereinigt wurden, und nach unserem Wissen frei von Rückständen in gefährbringender Menge sind.

P/SF/Kontam VIII

_____ (place, date / Ort, Datum)

_____ (Company stamp and legally binding signature)
(Firmenstempel und rechtsverbindliche Unterschrift)

15.12 Operating menu

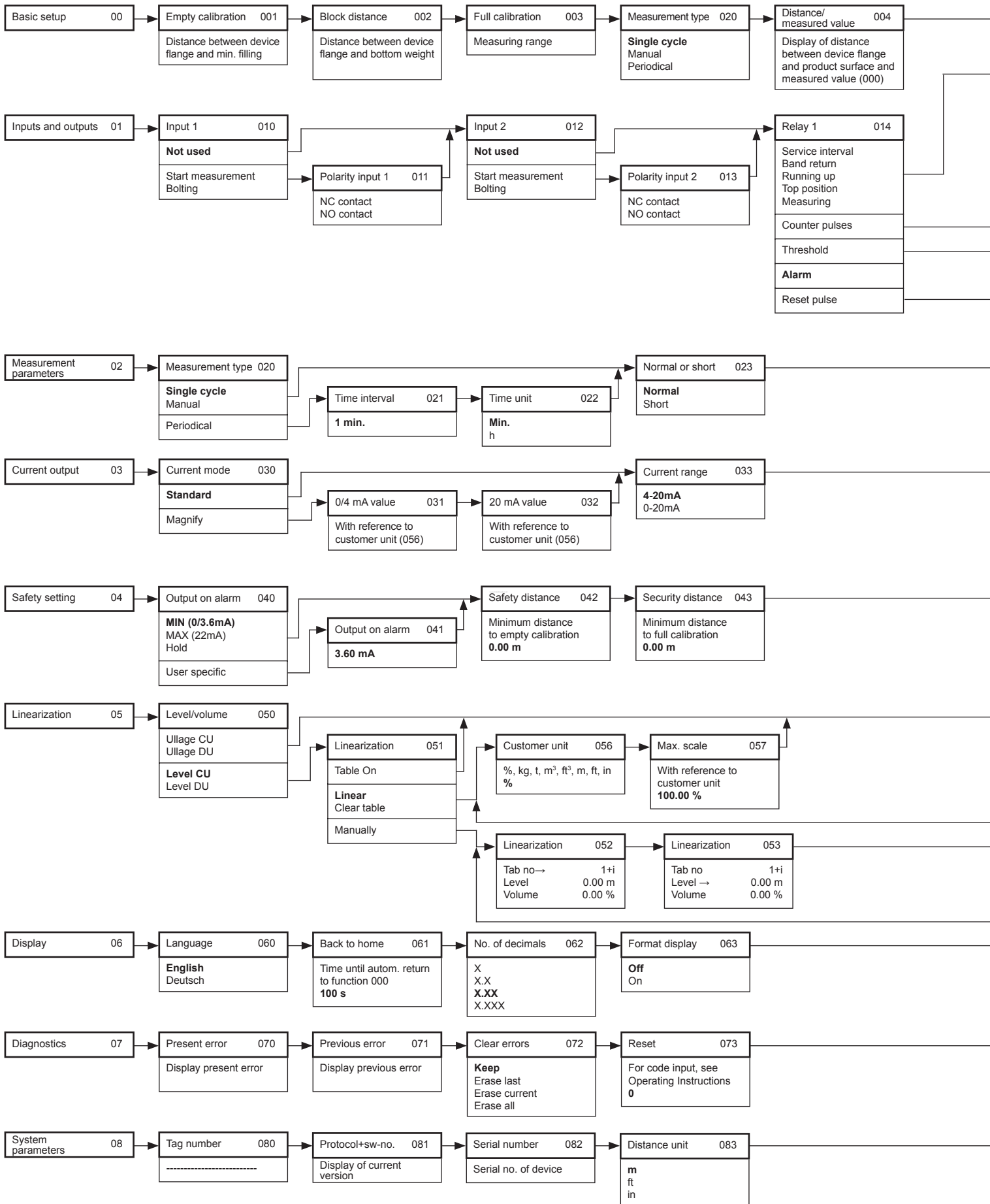

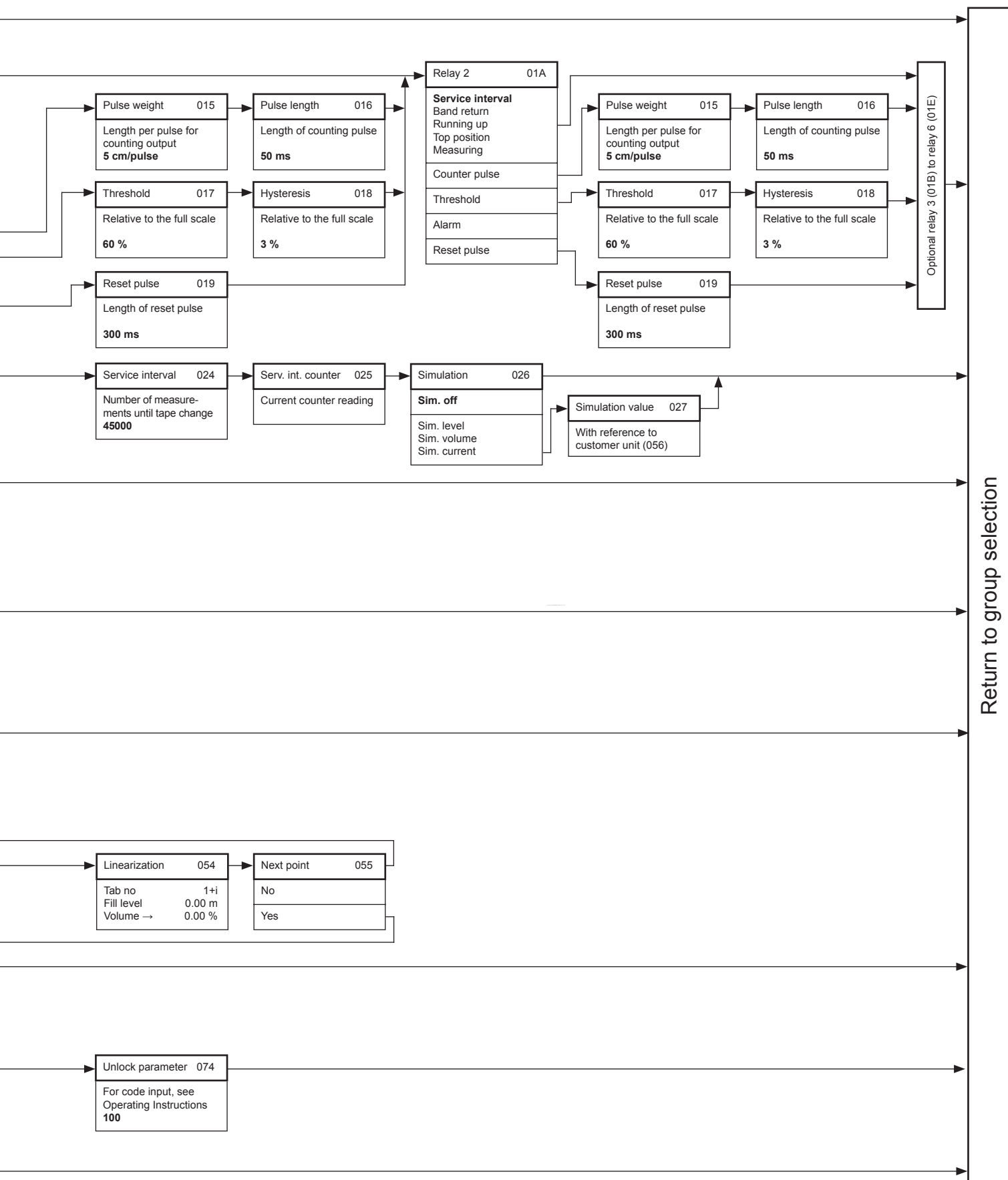

15.13 Software history

| Software version | Software modifications | Documentation modifications |
|-------------------------|---|------------------------------------|
| V 01.01.00 | Original software | |
| V 01.02.00 | Software expansion: – New functionalities (output current range 0 - 20 mA, function 033) | 52026800/06.05 |
| V 01.02.01 | Software expansion: – Factory settings (limit value motor voltage) | 52026800/06.05 |

15.14 EC type-examination certificate



Translation

EC-Type Examination Certificate

(1)

(2)

**- Directive 94/9/EC -
Equipment and protective systems intended for use
in potentially explosive atmospheres**

(3)

BVS 05 ATEX E 049

(4) **Equipment:** Level indicator Silopilot M Type FMM50-B(5) **Manufacturer:** Endress + Hauser GmbH + Co. KG(6) **Address:** D - 79689 Maulburg

(7) The design and construction of this equipment and any acceptable variation thereto are specified in the schedule to this type examination certificate.

(8) The certification body of EXAM BBG Prüf- und Zertifizier GmbH, notified body no. 0158 in accordance with Article 9 of the Directive 94/9/EC of the European Parliament and the Council of 23 March 1994, certifies that this equipment has been found to comply with the Essential Health and Safety Requirements relating to the design and construction of equipment and protective systems intended for use in potentially explosive atmospheres, given in Annex II to the Directive.

The examination and test results are recorded in the test and assessment report BVS PP 05.2034 EG.

(9) The Essential Health and Safety Requirements are assured by compliance with:

EN 50281-1-1:1998+A1 Dust explosion protection

(10) If the sign "X" is placed after the certificate number, it indicates that the equipment is subject to special conditions for safe use specified in the schedule to this certificate.

(11) This EC-Type Examination Certificate relates only to the design, examination and tests of the specified equipment in accordance to Directive 94/9/EC.

Further requirements of the Directive apply to the manufacturing process and supply of this equipment. These are not covered by this certificate.

(12) The marking of the equipment shall include the following:

 **II 1/2D IP67 T 99 °C**

EXAM BBG Prüf- und Zertifizier GmbH

Bochum, dated 21. March 2005

Signed: Dr. Eickhoff

Signed: Leiendecker

 Certification body

 Special services unit



(13) Appendix to

(14) **EC-Type Examination Certificate**

BVS 05 ATEX E 049

(15) 15.1 Subject and type

Level indicator Silopilot M type FMM50-B

15.2 Description

The level indicator Silopilot M type FMM50-B is used for the detection of the level in containers for powdery or dust generating material.

It consists of a 2part aluminium enclosure (switching department and rope department): The rope department with the mechanical components inside meets category 1D whereas the switching department with the electrical components inside meets category 2D.

15.3 Parameters

15.3.1 Electrical data

15.3.1.1 Supply circuit
voltage
frequency
power
without heating
with heating

| | | |
|----|----------|----|
| AC | 90...253 | V |
| | 50/ 60 | Hz |
| | 230 | VA |
| | 260 | VA |

15.3.1.2 Input circuits
voltage

| | | |
|----|---------|---|
| DC | 12...24 | V |
|----|---------|---|

15.3.1.3 Output circuits
current output (HART)

| | |
|---------|----|
| 4... 20 | mA |
|---------|----|

relay output (6 relais)
switching voltage
switching current

| | | | |
|------|----|-----|---|
| max. | AC | 250 | V |
| max. | | 6 | A |

serial data bus (PROFIBUS)

15.3.2 Thermal data

maximum surface temperature T
limited with thermo fuse

| | |
|----|----|
| 99 | °C |
|----|----|

permitted ambient temperature

| | |
|--------------|----|
| -35 °C...+70 | °C |
|--------------|----|

15.3.3 Degrees of protection according to EN 60529

IP 67



- (16) Test and assessment report
BVS PP 05.2034 EG as of 21.03.2005
- (17) Special conditions for safe use
None

We confirm the correctness of the translation from the German original.
In the case of arbitration only the German wording shall be valid and binding.

44809 Bochum, 21. March 2005
BVS-Hk/Kw A 20050148

EXAM BBG Prüf- und Zertifizier GmbH



Certification body



Special services unit



(1) **EG-Baumusterprüfbescheinigung**

(2) **- Richtlinie 94/9/EG -**
Geräte und Schutzsysteme zur bestimmungsgemäßen Verwendung
in explosionsgefährdeten Bereichen

(3) **BVS 05 ATEX E 049**

(4) **Gerät:** **Füllstandmessgerät Silopilot M Typ FMM50-B**

(5) **Hersteller:** **Endress + Hauser GmbH + Co. KG**

(6) **Anschrift:** **D - 79689 Maulburg**

(7) Die Bauart dieses Gerätes sowie die verschiedenen zulässigen Ausführungen sind in der Anlage zu dieser Baumusterprüfbescheinigung festgelegt.

(8) Die Zertifizierungsstelle der EXAM BBG Prüf- und Zertifizier GmbH, benannte Stelle Nr. 0158 gemäß Artikel 9 der Richtlinie 94/9/EG des Europäischen Parlaments und des Rates vom 23. März 1994, bescheinigt, dass das Gerät die grundlegenden Sicherheits- und Gesundheitsanforderungen für die Konzeption und den Bau von Geräten und Schutzsystemen zur bestimmungsgemäßen Verwendung in explosionsgefährdeten Bereichen gemäß Anhang II der Richtlinie erfüllt.
 Die Ergebnisse der Prüfung sind in dem Prüfprotokoll BVS PP 05.2034 EG niedergelegt.

(9) Die grundlegenden Sicherheits- und Gesundheitsanforderungen werden erfüllt durch Übereinstimmung mit
 EN 50281-1-1:1998+A1 Staubexplosionsschutz

(10) Falls das Zeichen „X“ hinter der Bescheinigungsnummer steht, wird in der Anlage zu dieser Bescheinigung auf besondere Bedingungen für die sichere Anwendung des Gerätes hingewiesen.

(11) Diese EG-Baumusterprüfbescheinigung bezieht sich nur auf die Konzeption und die Baumusterprüfung des beschriebenen Gerätes in Übereinstimmung mit der Richtlinie 94/9/EG.
 Für Herstellung und in Verkehr bringen des Gerätes sind weitere Anforderungen der Richtlinie zu erfüllen, die nicht durch diese Bescheinigung abgedeckt sind.

(12) Die Kennzeichnung des Gerätes muss die folgenden Angaben enthalten:

II 1/2D IP67 T 99 °C

EXAM BBG Prüf- und Zertifizier GmbH

Bochum, den 21. März 2005

 Zertifizierungsstelle

 Fachbereich



(13) Anlage zur

(14) **EG-Baumusterprüfbescheinigung**

BVS 05 ATEX E 049

(15) 15.1 Gegenstand und Typ
Füllstandmessgerät Silopilot M Typ FMM50-B

15.2 Beschreibung

Das Füllstandmessgerät Silopilot M Typ FMM50-B dient der Messung des Füllstandes in Behältern für staubförmige oder staubentwickelnde brennbare Schüttgüter.

Es besteht aus einem 2teiligen Aluminiumgehäuse (Schalt- und Seilraum), wobei der Seilraum mit den darin befindlichen mechanischen Komponenten der Kategorie 1D entspricht, während der Schaltraum mit den elektrischen Komponenten der Kategorie 2D entspricht.

15.3 Kenngrößen

15.3.1 Elektrische Daten

15.3.1.1 Versorgungsstromkreis

| | | | |
|-----------------------------------|----|----------|----|
| Spannung | AC | 90...253 | V |
| Frequenz | | 50/ 60 | Hz |
| Leistungsaufnahme ohne Heizung | | 230 | VA |
| mit Heizung | | 260 | VA |

15.3.1.2 Eingangsstromkreise
Spannung

DC 12...24 V

15.3.1.3 Ausgangsstromkreise
Stromausgang (HART)

4... 20 mA

Relaisausgang (6 Relais)

| | | | | |
|----------------|------|----|-----|---|
| Schaltspannung | max. | AC | 250 | V |
| Schaltstrom | max. | | 6 | A |

Serieller Datenbus (PROFIBUS)

15.3.2 Thermische Daten

Maximale Oberflächentemperatur T
durch Temperatursicherung begrenzt auf 99 °C

Zulässige Umgebungstemperatur -35 °C...+70 °C

15.3.3 Schutzart gemäß EN 60529

IP 67

(16) Prüfprotokoll
BVS PP 05.2034 EG, Stand 21.03.2005

(17) Besondere Bedingungen für die sichere Anwendung
Entfällt

15.15 EC declaration of conformity

(Version FMM50 - A)

EG-Konformitätserklärung EC Declaration of Conformity Déclaration CE de Conformité

Endress+Hauser GmbH+Co. KG, Hauptstraße 1, 79689 Maulburg

erklärt in alleiniger Verantwortung, dass das Produkt
declares in sole responsibility, that the product
déclare sous sa seule responsabilité que le produit

SILOPILOT M Füllstandmeßgerät

FMM 50



Level



Pressure



Flow



Temperature

Liquid
Analysis

Registration

Systems
Components

Services



Solutions

mit den Vorschriften folgender Europäischer Richtlinien übereinstimmt:
conforms with the regulations of the following European Directives:
est conforme aux prescriptions et directives Européennes suivantes:

EMV-Richtlinie 89/336/EWG

Niederspannungsrichtlinie 73/23/EWG

Angewandte harmonisierte Normen oder normative Dokumente:
Applied harmonised standards or normative documents:
Normes harmonisées ou documents normatifs appliqués:

EN 61326 (2001)

EN 61010-1 (2001)

Erstmalige Anbringung des CE-Zeichens:

2005

CE-mark first affixed:

Année de mise en conformité CE:

Maulburg, 08.03.2005

Endress + Hauser GmbH + Co. KG

i. V.

Leiter Zertifizierung
Certification Manager
Manager de Certification

Endress+Hauser 
People for Process Automation

(Version FMM50 - B)

EG-Konformitätserklärung EC Declaration of Conformity Déclaration CE de Conformité

Endress+Hauser GmbH+Co. KG, Hauptstraße 1, 79689 Maulburg

erklärt in alleiniger Verantwortung, dass das Produkt
declares in sole responsibility, that the product
déclare sous sa seule responsabilité que le produit



Level



Pressure



Flow



Temperature



Liquid Analysis



Registration



Systems Components



Services



Solutions

SILOPILOT M Füllstandmeßgerät

FMM 50

mit den Vorschriften folgender Europäischer Richtlinien übereinstimmt:
conforms with the regulations of the following European Directives:
est conforme aux prescriptions et directives Européennes suivantes:

EMV-Richtlinie 89/366/EWG

Ex-Richtlinie 94/9/EG

Angewandte harmonisierte Normen oder normative Dokumente:

Applied harmonised standards or normative documents:

Normes harmonisées ou documents normatifs appliqués:

| | | | |
|-------------------|---------------|---------------------|------------------|
| EN 61326 | (2003) | EN 50281-1-1 | (1998+A1) |
| EN 61010-1 | (2001) | EN 60529 | (1991+A1) |

EG-Baumusterprüfbescheinigung Nr:

BVS 05 ATEX E 049

EC-Type Examination Certificate No:

Numéro de l'attestation d'examen CE de type:

Benannte Stelle:

TÜV Hannover/Nr. 0032

Notified body performing the QA surveillance:

Organisme notifié de contrôle du système de qualité:

Erstmalige Anbringung des CE-Zeichens:

05

CE-mark first affixed:

Année de mise en conformité CE:

Maulburg, 04.04.2005

Endress + Hauser GmbH + Co. KG

ppa.

Hauptbereichsleiter Füllstandmesstechnik
Director Level Measurement
Le Directeur du Département Mesure Niveau

Endress+Hauser

People for Process Automation

Index

A

| | |
|------------------------|-----------|
| Accessories | 75 |
| Activation period..... | 44, 77 |
| ATEX | 5, 11, 87 |

B

| | |
|----------------------|----|
| Basic setup | 38 |
| Block distance | 38 |

C

| | |
|----------------------|--------|
| CE mark | 11, 92 |
| Commissioning | 35 |
| Counting pulse | 42 |
| Current output | 28, 48 |

D

| | |
|--------------------------------------|--------|
| Diagnostics | 55 |
| Dimensions, housing | 17 |
| Dimensions, process connection | 18 |
| Display | 32, 54 |
| Drive unit | 67 |

E

| | |
|--------------------------------------|--------|
| EC type-examination certificate..... | 87 |
| EC declaration of conformity | 92 |
| Electrical connection..... | 26 |
| Electronic unit | 68 |
| Empty calibration | 38 |
| Error | 55, 59 |
| Error codes | 60 |

F

| | |
|------------------------|----|
| Full calibration | 39 |
|------------------------|----|

H

| | |
|--------------------------|----|
| Housing dimensions | 17 |
|--------------------------|----|

I

| | |
|---|--------|
| Inputs and outputs | 28, 40 |
| Installation..... | 20 |
| Installation, location and planning | 16 |
| Installation, sensing weight | 22 |
| Intended use | 4 |

K

| | |
|----------------------|----|
| Key assignment | 32 |
|----------------------|----|

L

| | |
|---------------------|--------|
| Linearization | 50, 81 |
|---------------------|--------|

M

| | |
|------------------------|--------|
| Manual mode | 39, 57 |
| Maintenance..... | 45, 62 |
| Measurement type | 39 |
| Measuring tape | 63, 65 |

N

| | |
|-----------------|---|
| Nameplate | 7 |
|-----------------|---|

O

| | |
|----------------------|--------|
| Operation | 31 |
| Operating menu | 33, 84 |
| Operating mode | 45 |
| Output | 28 |

P

| | |
|----------------------------|--------|
| Potential matching | 26 |
| Power supply | 28, 77 |
| Process connection | 18, 24 |
| Product structure | 8 |
| Protective hood | 75 |
| Pulse weight, length | 42 |

R

| | |
|---------------------|--------|
| Relay outputs | 29, 41 |
| Repair | 64 |
| Returns | 74 |

S

| | |
|----------------------------------|------------|
| Safety settings | 49 |
| Safety instructions (ATEX) | 4 |
| Safety signals and symbols | 6 |
| Scope of delivery..... | 10 |
| Sensing weights | 12, 22, 73 |
| Settings..... | 79 |
| Sight glass | 19 |
| Signal inputs | 29 |
| Simulation | 46 |
| Spare parts | 69 |
| Start button | 19, 30 |
| System parameters | 56 |

T

| | |
|---------------------------|----|
| Technical data | 76 |
| Terminal assignment | 27 |
| Troubleshooting | 59 |

U

| | |
|------------------------|----|
| Unlock parameter | 55 |
|------------------------|----|

V

| | |
|-------------------------|----|
| Wiring | 26 |
| Locking/unlocking | 34 |
| Supply voltage | 28 |

W

| | |
|-------------|------------|
| Wiper | 17, 62, 66 |
|-------------|------------|

www.endress.com/worldwide

Endress+Hauser 
People for Process Automation