

**54, 74 Series GHz Logic**

FEATURES:	DESCRIPTION:
<ul style="list-style-type: none"> <li>. Patented technology</li> <li>. Specified From -40°C to 85°C, -40°C to 125°C, and -55°C to 125°C</li> <li>. Operating frequency up to 1.125GHz with 2pf load</li> <li>. Operating frequency up to 750MHz with 5pf load</li> <li>. Operating frequency up to 350MHz with 15pf load</li> <li>. Vcc Operates from 1.65V to 3.6V</li> <li>. Propagation delay &lt; 1.5ns max with 15pf load</li> <li>. Low input capacitance: 4pf typical</li> <li>. Latch-Up Performance Exceeds 250 mA Per JESD 17</li> <li>. ESD Protection Exceeds JESD 22</li> <li>. 2000-VHuman-BodyModel (A114-A)</li> <li>. 200-VMachineModel (A115-A)</li> <li>. 1000-VCharged-DeviceModel (C101)</li> <li>. Available in 14pin 150mil wide SOIC package</li> <li>. Available in 14pin Ceramic Dual Flatpack</li> <li>. Available in 20pin Leadless Ceramic Chip Carrier</li> </ul>	<p>Potato Semiconductor's PO74G00A is designed for world top performance using submicron CMOS technology to achieve 1.125GHz TTL/CMOS output frequency with less than 1.5ns propagation delay.</p> <p>This quadruple 2-input positive-NAND gate is designed for 1.65-V to 3.6-V VCC operation.</p> <p>The PO74G00A performs the Boolean function <math>Y = \overline{A \cdot B}</math> or <math>Y = \overline{A} + \overline{B}</math> in positive logic.</p> <p>Inputs can be driven from either 3.3V or 5V devices. This feature allows the use of these devices as translators in a mixed 3.3V/5V system environment.</p>

**Pin Configuration**

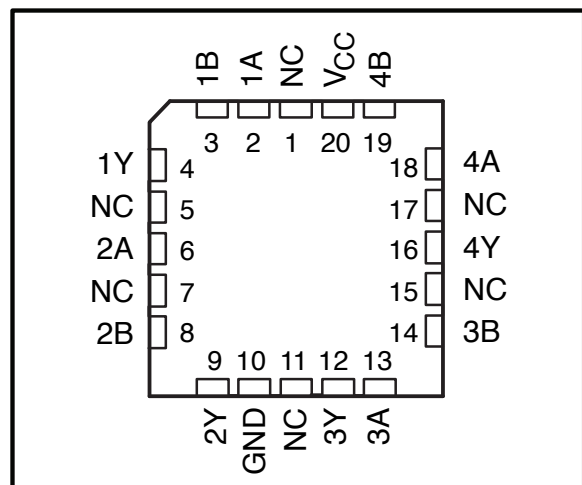
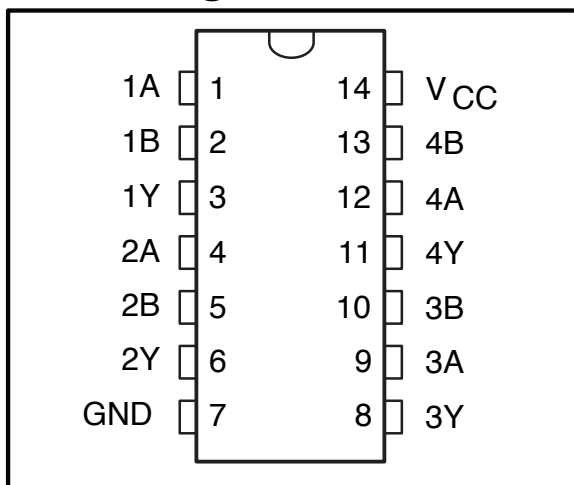

**Pin Description**

INPUTS		OUTPUT
A	B	Y
H	H	L
L	X	H
X	L	H

**Logic Block Diagram**

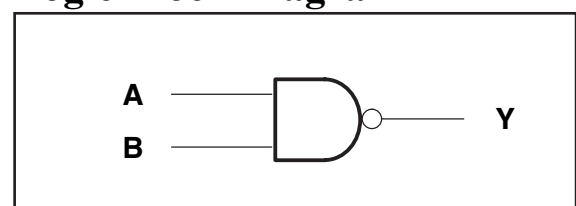

## 54, 74 Series GHz Logic

### Maximum Ratings

Description	Max	Unit
Storage Temperature	-65 to 150	°C
Operation Temperature	-55 to 125	°C
Operation Voltage	-0.5 to +4.6	V
Input Voltage	-0.5 to +5.5	V
Output Voltage	-0.5 to V <sub>cc</sub> +0.5	V

**Note:**

stresses greater than listed under Maximum Ratings may cause permanent damage to the device. This is a stress rating only and functional operation of the device at these or any other conditions above those indicated in the operational sections of this specification is not implied. Exposure to absolute maximum rating conditions for extended periods may affect reliability specification is not implied.

### DC Electrical Characteristics

Symbol	Description	Test Conditions	Min	Typ	Max	Unit
<b>V<sub>OH</sub></b>	Output High voltage	V <sub>cc</sub> =3V Vin=V <sub>IH</sub> or V <sub>IL</sub> , I <sub>OH</sub> = -12mA	<b>2.4</b>	<b>3</b>	-	<b>V</b>
<b>V<sub>OL</sub></b>	Output Low voltage	V <sub>cc</sub> =3V Vin=V <sub>IH</sub> or V <sub>IL</sub> , I <sub>OH</sub> =12mA	-	<b>0.3</b>	<b>0.5</b>	<b>V</b>
<b>V<sub>IH</sub></b>	Input High voltage	Guaranteed Logic HIGH Level (Input Pin)	<b>2</b>	-	<b>5.5</b>	<b>V</b>
<b>V<sub>IL</sub></b>	Input Low voltage	Guaranteed Logic LOW Level (Input Pin)	<b>-0.5</b>	-	<b>0.8</b>	<b>V</b>
<b>I<sub>IH</sub></b>	Input High current	V <sub>cc</sub> = 3.6V and Vin = 5.5V	-	-	<b>5</b>	<b>uA</b>
<b>I<sub>IL</sub></b>	Input Low current	V <sub>cc</sub> = 3.6V and Vin = 0V	-	-	<b>-5</b>	<b>uA</b>
<b>V<sub>IK</sub></b>	Clamp diode voltage	V <sub>cc</sub> = Min. And I <sub>IN</sub> = -18mA	-	<b>-0.7</b>	<b>-1.2</b>	<b>V</b>

**Notes:**

1. For conditions shown as Max. or Min., use appropriate value specified under Electrical Characteristics for the applicable device type.
2. Typical values are at V<sub>cc</sub> = 3.3V, 25 °C ambient.
3. This parameter is guaranteed but not tested.
4. Not more than one output should be shorted at one time. Duration of the test should not exceed one second.
5. V<sub>OH</sub> = V<sub>cc</sub> - 0.6V at rated current

## 54, 74 Series GHz Logic

### Power Supply Characteristics

Symbol	Description	Test Conditions (1)	Min	Typ	Max	Unit
<b>IccQ</b>	Quiescent Power Supply Current	Vcc=Max, Vin=Vcc or GND	-	<b>0.1</b>	<b>40</b>	<b>uA</b>
<b>ΔIcc</b>	Power Supply Current per Input High	Vcc=Max, Vin= Vcc-0.6V	-	<b>50</b>	<b>500</b>	<b>uA</b>

**Notes:**

1. For conditions shown as Max. or Min., use appropriate value specified under Electrical Characteristics for the applicable device type.
2. Typical values are at Vcc = 3.3V, 25°C ambient.
3. This parameter is guaranteed but not tested.
4. Not more than one output should be shorted at one time. Duration of the test should not exceed one second.
5. VoH = Vcc – 0.6V at rated current

### Capacitance

Parameters (1)	Description	Test Conditions	Typ	Unit
<b>Cin</b>	Input Capacitance	Vin = 0V	<b>4</b>	<b>pF</b>
<b>Cout</b>	Output Capacitance	Vout = 0V	<b>6</b>	<b>pF</b>

**Notes:**

- 1 This parameter is determined by device characterization but not production tested.

### Switching Characteristics

Symbol	Description	Test Conditions (1)	Max	Unit
<b>tPLH</b>	Propagation Delay A, B to Y	CL = 15pF	<b>1.5</b>	<b>ns</b>
<b>tPHL</b>	Propagation Delay A, B to Y	CL = 15pF	<b>1.5</b>	<b>ns</b>
<b>tr/tf</b>	Rise/Fall Time	0.8V – 2.0V	<b>0.8</b>	<b>ns</b>
<b>fmax</b>	Input Frequency	CL =15pF	<b>350</b>	<b>MHz</b>
<b>fmax</b>	Input Frequency	CL = 5pF	<b>750</b>	<b>MHz</b>
<b>fmax</b>	Input Frequency	CL = 2pF	<b>1125</b>	<b>MHz</b>

**Notes:**

1. See test circuits and waveforms.
2. tPLH, tPHL, tsk(p), and tsk(o) are production tested. All other parameters guaranteed but not production tested.
3. Airflow of 1m/s is recommended for frequencies above 133MHz

**54, 74 Series GHz Logic**

**Test Waveforms**

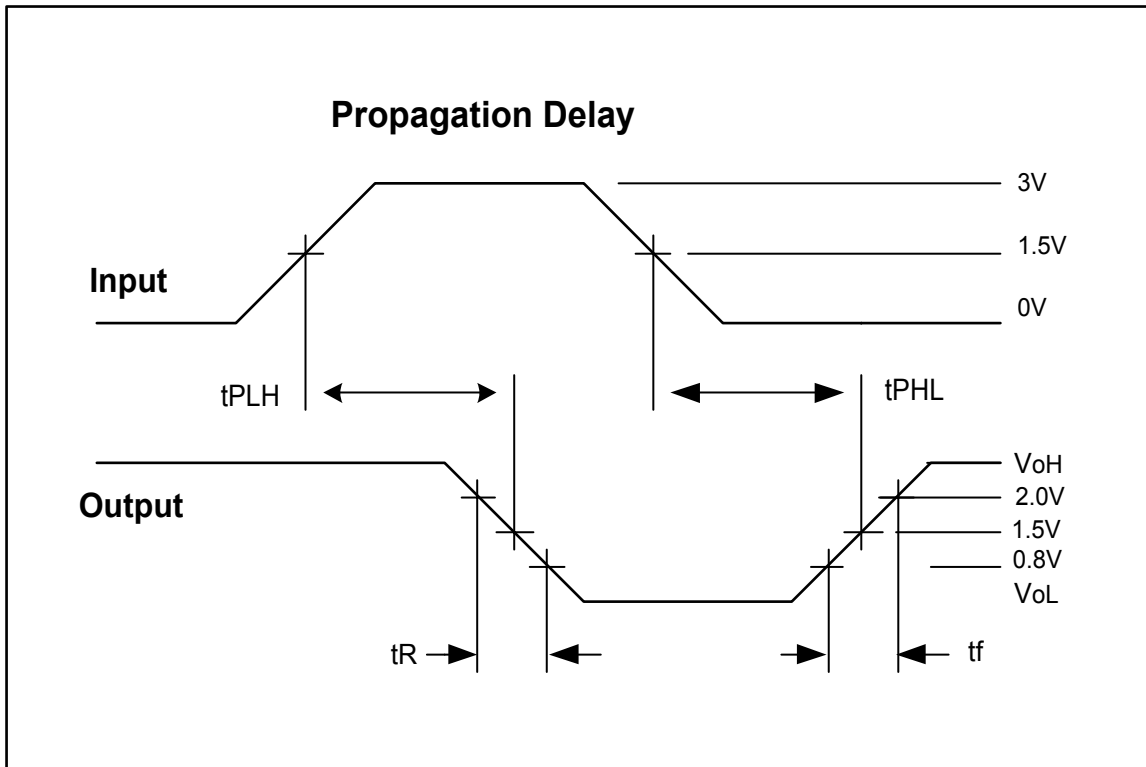

**Test Circuit**

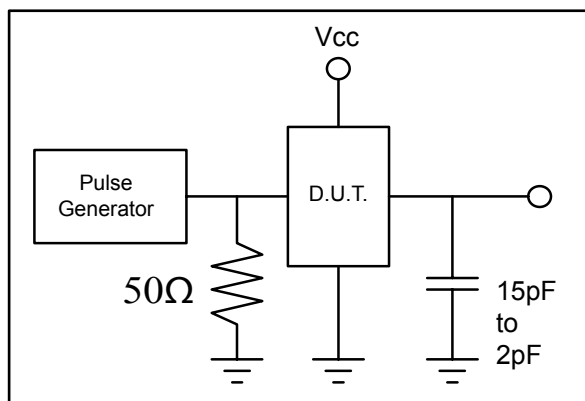

**54, 74 Series GHz Logic**

**Packaging Mechanical Drawing: 14 pin 150mil SOIC**

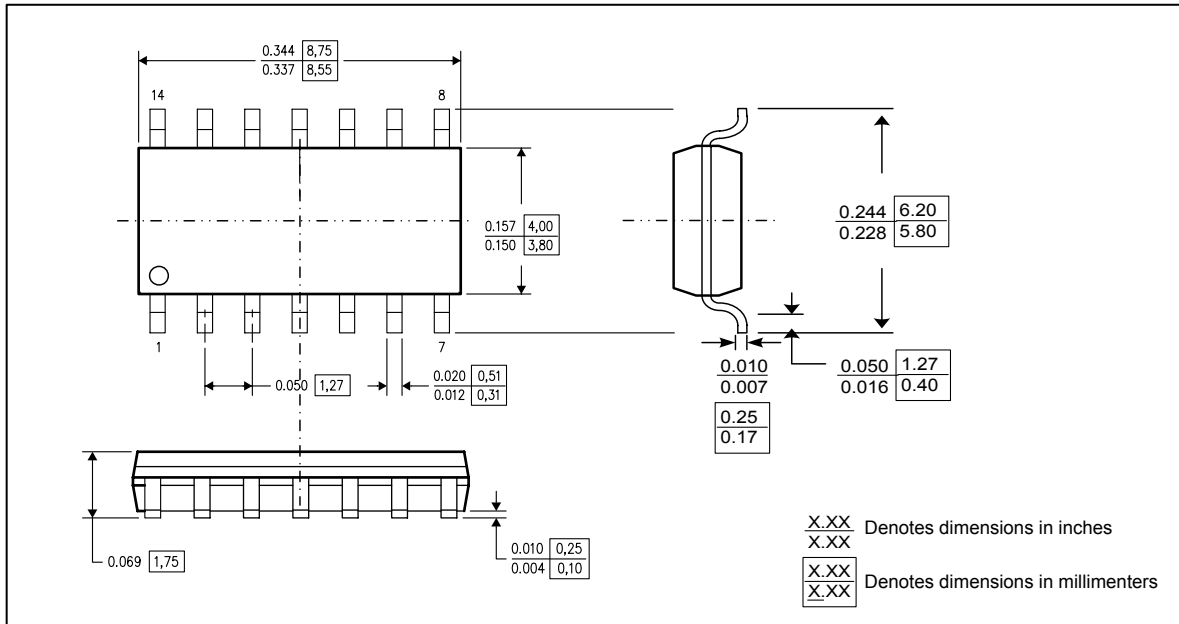

**Packaging Mechanical Drawing: 14pin Leadless Ceramic Chip Carrier**

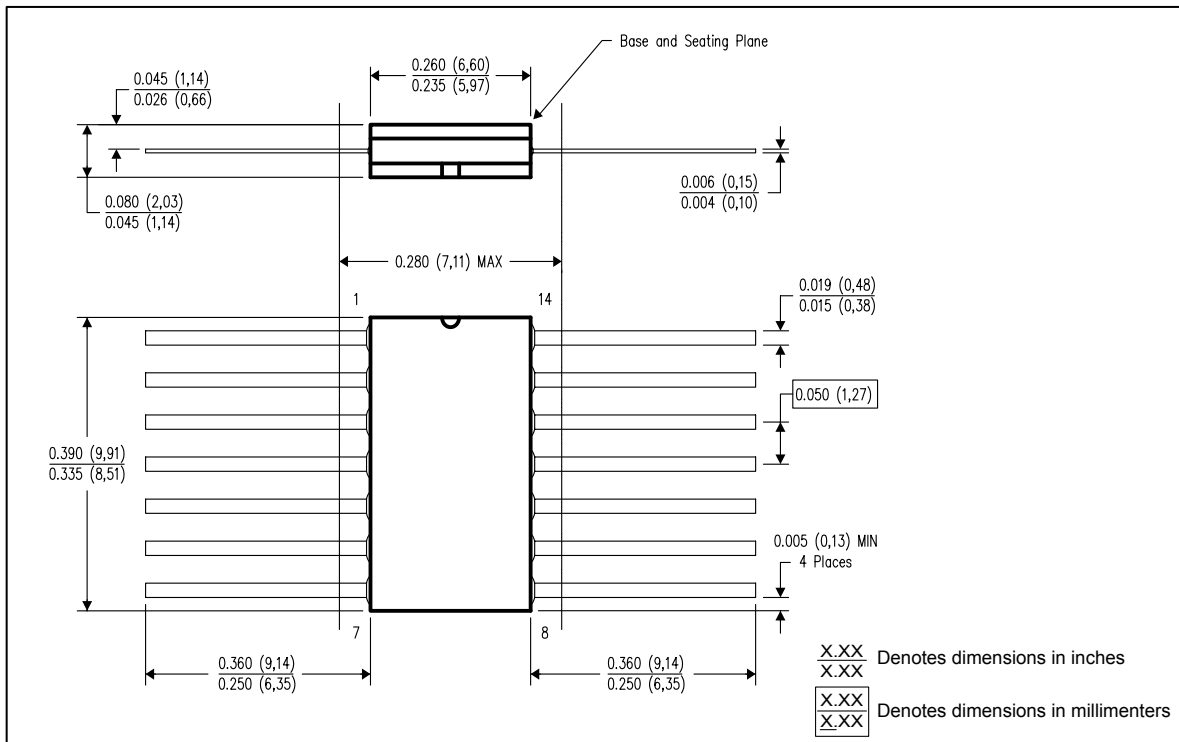

54, 74 Series GHz Logic

Packaging Mechanical Drawing: 20pin Ceramic Dual Flatpack

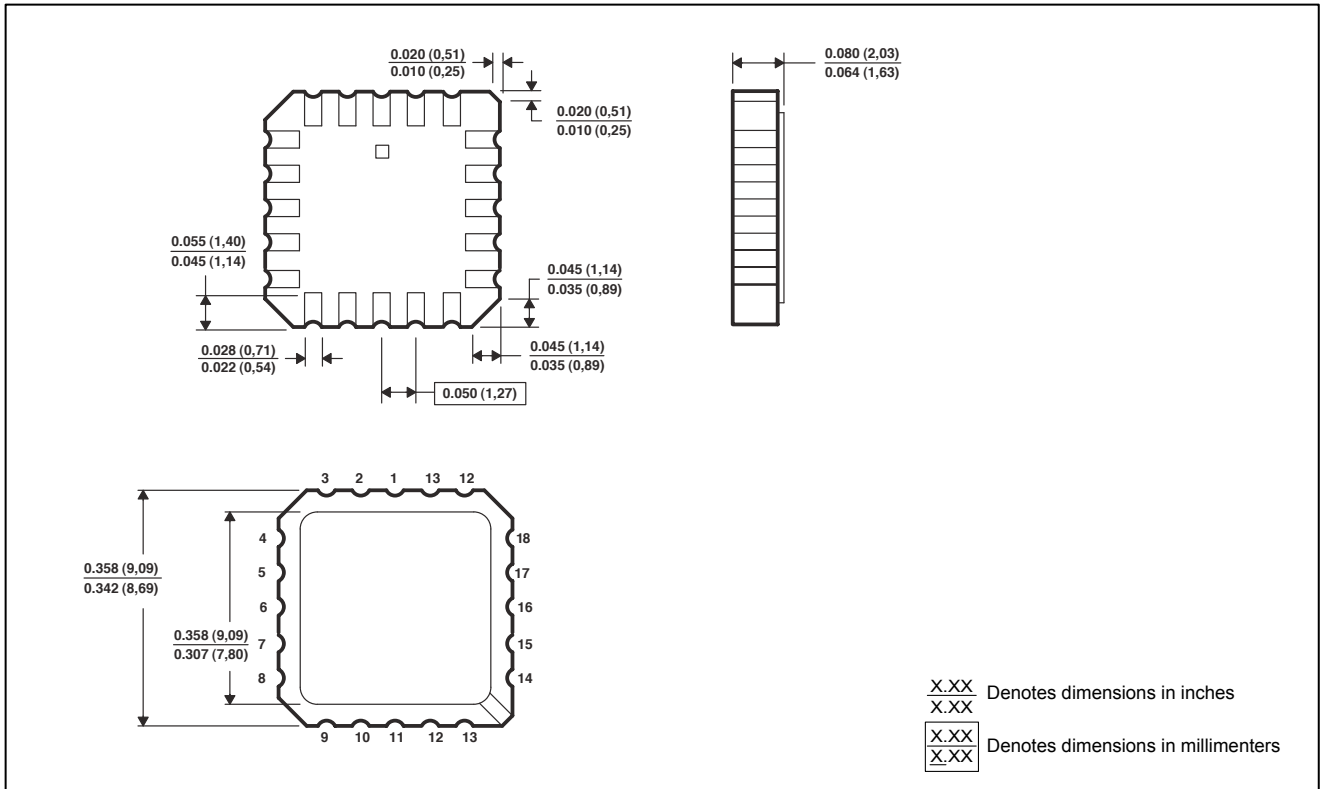

Ordering Information

Ordering Code	Package			Top-Marking	T <sub>A</sub>
PO74G00ASU	14pin SOIC	Tube	Pb-free & Green	PO74G00AS	-40°C to 85°C
PO74G00ASR	14pin SOIC	Tape and reel	Pb-free & Green	PO74G00AS	-40°C to 85°C
PO74G00ASiU	14pin SOIC	Tube	Pb-free & Green	PO74G00ASi	-40°C to 125°C
PO74G00ASiR	14pin SOIC	Tape and reel	Pb-free & Green	PO74G00ASi	-40°C to 125°C
PO54G00ALU	14pin Leadless Ceramic Chip Carrier	Tube	Pb-free & Green	PO54G00AL	-55°C to 125°C
PO54G00AFU	20pin Ceramic Dual Flatpack	Tube	Pb-free & Green	PO54G00AF	-55°C to 125°C