

RoHS Compliant Product
A suffix of "-C" specifies halogen & lead-free

DESCRIPTION

The BCP2098 is an epitaxial planar type NPN silicon transistor.

FEATURES

- Excellent DC Current Gain Characteristics
- Low Saturation Voltage, Typically $V_{CE(SAT)}=0.25V$
At $I_C / I_B=4A / 0.1A$

CLASSIFICATION OF h_{FE} (1)

Product-Rank	BCP2098-Q	BCP2098-R
Range	120~270	180~390

PACKAGE INFORMATION

Package	MPQ	Leader Size
SOT-89	1K	13' inch

SOT-89

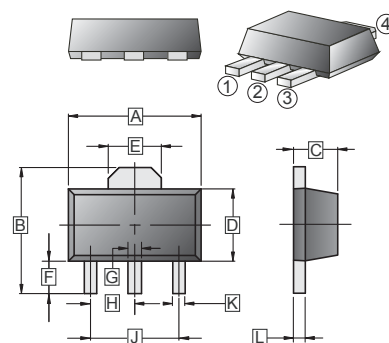

REF.	Millimeter		REF.	Millimeter	
	Min.	Max.		Min.	Max.
A	4.40	4.60	G	0.40	0.58
B	3.94	4.25	H	1.50	TYP
C	1.40	1.60	J	3.00	TYP
D	2.30	2.60	K	0.32	0.52
E	1.50	1.70	L	0.35	0.44
F	0.89	1.20			

ABSOLUTE MAXIMUM RATINGS ($T_A = 25^\circ C$ unless otherwise specified)

Parameter	Symbol	Ratings	Unit
Collector-Base Voltage	V_{CBO}	50	V
Collector-Emitter Voltage	V_{CEO}	20	V
Emitter-Base Voltage	V_{EBO}	6	V
Collector Current -Continuous	I_C	5	A
Collector Current (Pulse) ¹	I_{CP}	10	A
Total Power Dissipation	P_D	0.5(2.0) ²	W
Junction & Storage temperature	T_J, T_{STG}	-55~150	$^\circ C$

Note:

1. Single pulse, $PW=10ms$.
2. When mounted on a $40*40*0.7mm$ ceramic board.

ELECTRICAL CHARACTERISTICS ($T_A = 25^\circ C$ unless otherwise specified)

Parameters	Symbol	Min.	Typ.	Max.	Unit	Test Conditions
Collector-base breakdown voltage	$V_{(BR)CBO}$	50	-	-	V	$I_C=50\mu A, I_E=0$
Collector-emitter breakdown	$V_{(BR)CEO}$	20	-	-	V	$I_C=1mA, I_B=0$
Emitter-base breakdown voltage	$V_{(BR)EBO}$	6	-	-	V	$I_E=50\mu A, I_C=0$
Collector cut-off current	I_{CBO}	-	-	0.5	μA	$V_{CB}=40V, I_E=0$
Emitter cut-off current	I_{EBO}	-	-	0.5	μA	$V_{EB}=5V, I_C=0$
DC current gain	h_{FE}	120	-	390		$V_{CE}=2V, I_C=0.5A$
Collector-emitter saturation voltage ¹	$V_{CE(sat)}$	-	0.25	1	V	$I_C=4A, I_B=0.1A$
Transition frequency	f_T	-	150	-	MHz	$V_{CE}=6V, I_C=50mA, f=100MHz$
Output Capacitance	C_{OB}	-	30	-	pF	$V_{CB}=20V, I_E=0, f=1MHz$

Note:

1. Measured under pulse condition. Pulse width $\leq 300\mu s$, Duty Cycle $\leq 2\%$.

CHARACTERISTIC CURVES

Grounded Emitter Propagation Characteristics

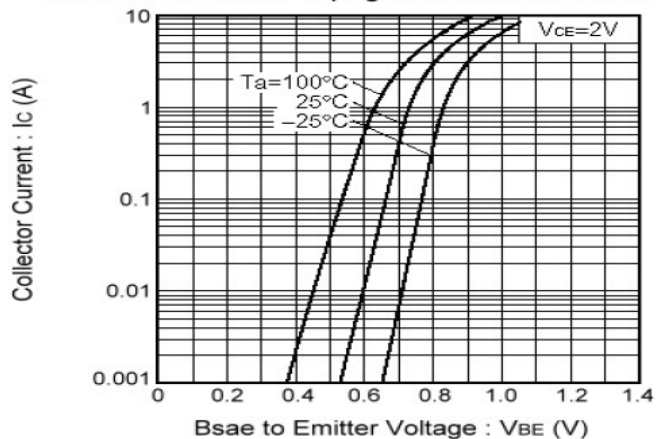

Grounded Emitter Output Characteristics

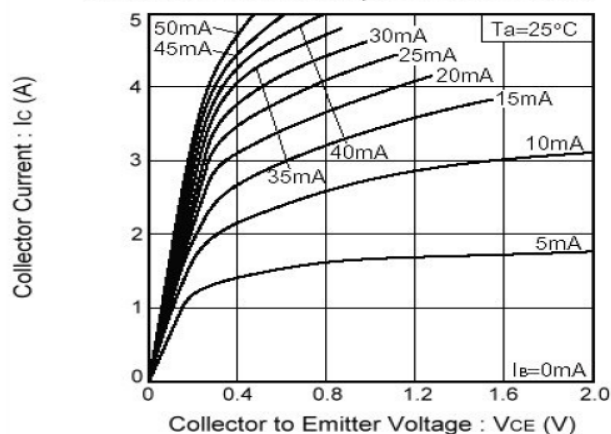

DC Current Gain & Collector Current (I)

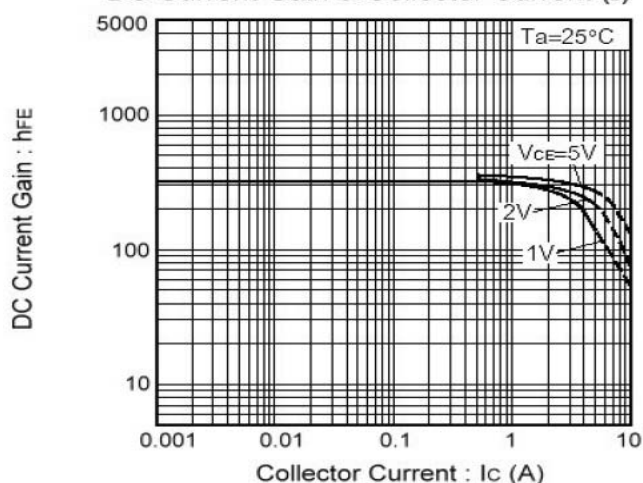

DC Current Gain & Collector Current (II)

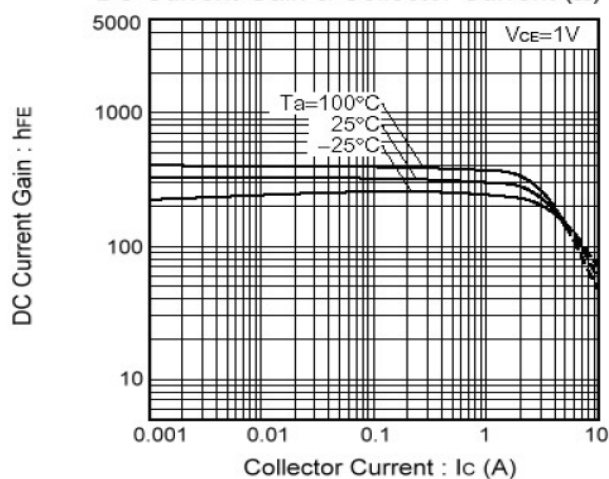

DC Current Gain & Collector Current (III)

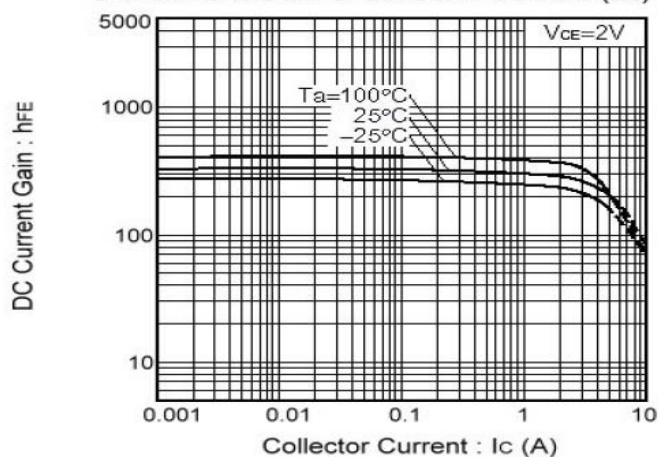

Safe Operating Area

