

QL3040 - pASIC 3 FPGA™



40,000 Usable PLD Gate pASIC 3 FPGA Combining High Performance and High Density

DEVICE HIGHLIGHTS

High Performance & High Density

- 40,000 Usable PLD Gates with 252 I/Os
- 16-bit counter speeds over 300 MHz, data path speeds over 400 MHz
- 0.35µm four-layer metal non-volatile CMOS process for smallest die sizes

Easy to Use / Fast Development Cycles

- 100% routable with 100% utilization and complete pin-out stability
- Variable-grain logic cells provide high performance and 100% utilization
- Comprehensive design tools include high quality Verilog/VHDL synthesis

Advanced I/O Capabilities

- Interfaces with both 3.3V and 5.0V devices
- PCI compliant with 3.3V and 5.0V buses for -1/-2/-3/-4 speed grades
- Full JTAG boundary scan
- Registered I/O cells with individually controlled clocks and output enables

Total of 252 I/O Pins

- 244 bidirectional input/output pins, PCI-compliant for 5.0V and 3.3V buses for -1/-2/-3/-4 speed grades
- 8 high-drive input/distributed network pins

Eight Low-Skew Distributed Networks

- Two array clock/control networks available to the logic cell flip-flop clock, set and reset inputs - each driven by an input-only pin
- Six global clock/control networks available to the logic cell F1, clock set and reset inputs and the input and I/O register clock, reset and enable inputs as well as the output enable control - each driven by an input-only or I/O pin, or any logic cell output or I/O cell feedback

High Performance

- Input + logic cell + output total delays under 6 ns
- Data path speeds over 400 MHz
- Counter speeds over 300 MHz

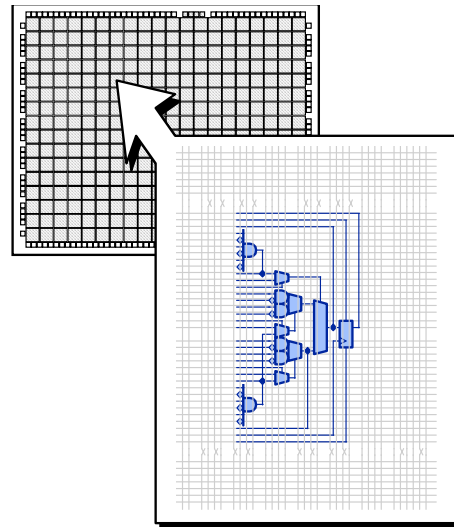

FIGURE 1. 1,008 Logic Cells

PRODUCT SUMMARY

The QL3040 is a 40,000 usable PLD gate member of the pASIC 3 family of FPGAs. pASIC 3 FPGAs are fabricated on a 0.35µm four-layer metal process using QuickLogic's patented ViaLink technology to provide a unique combination of high performance, high density, low cost, and extreme ease-of-use.

The QL3040 contains 1,008 logic cells. With a maximum of 252 I/Os, the QL3040 is available in 208-PQFP and 456-pin PBGA packages.

Software support for the complete pASIC 3 family, including the QL3040, is available through three basic packages. The turnkey QuickWorks™ package provides the most complete FPGA software solution from design entry to logic synthesis, to place and route, to simulation. The QuickChip™ and QuickTools™ packages provide a solution for designers who use Cadence, Exemplar, Mentor, Synopsys, Synplicity, Viewlogic, Veribest, or other third-party tools for design entry, synthesis, or simulation.

208-PIN PQFP PINOUT DIAGRAM

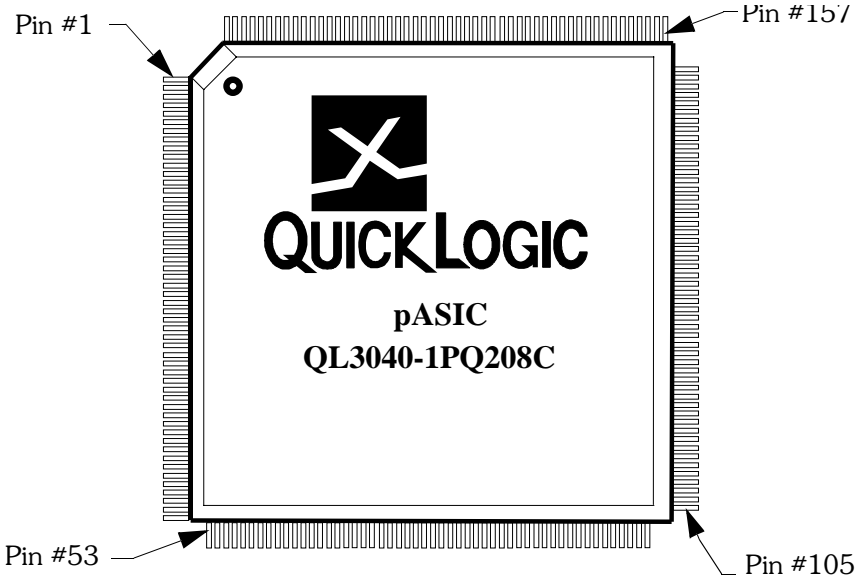

FIGURE 2. 208-Pin PQFP

QL3040 - pASIC 3 FPGATM

208 PQFP PINOUT TABLE

208 PQFP	Function	208 PQFP	Function	208 PQFP	Function	208 PQFP	Function	208 PQFP	Function
208	I/O	43	GND	84	I/O	125	I/O	168	I/O
1	I/O	44	I/O	85	I/O	126	I/O	169	I/O
2	I/O	45	I/O	86	I/O	127	GND	NC	I/O
3	I/O	46	I/O	87	I/O	128	I/O	170	I/O
4	I/O	47	I/O	88	I/O	NC	I/O	171	I/O
5	I/O	48	I/O	89	I/O	129	GCLK/I	172	I/O
NC	I/O	NC	I/O	90	I/O	130	ACLK/I	173	I/O
6	I/O	49	I/O	91	I/O	131	VCC	174	I/O
7	I/O	50	I/O	92	I/O	132	GCLK/I	175	I/O
8	I/O	51	I/O	NC	I/O	133	GCLK/I	NC	I/O
9	I/O	52	I/O	93	I/O	134	VCC	176	I/O
10	VCC	53	I/O	94	I/O	135	I/O	177	GND
11	I/O	54	TDI	95	GND	136	I/O	178	I/O
12	GND	NC	I/O	96	I/O	NC	I/O	179	I/O
13	I/O	NC	I/O	97	VCC	137	I/O	NC	I/O
14	I/O	55	I/O	98	I/O	NC	GND	180	I/O
NC	I/O	56	I/O	99	I/O	138	I/O	181	I/O
15	I/O	NC	I/O	100	I/O	139	I/O	182	GND
16	I/O	57	I/O	NC	I/O	140	I/O	NC	VCC
17	I/O	58	I/O	101	I/O	141	I/O	183	I/O
18	I/O	59	GND	NC	I/O	142	I/O	184	I/O
19	I/O	60	I/O	102	I/O	NC	I/O	185	I/O
20	I/O	61	VCC	NC	I/O	143	I/O	186	I/O
NC	I/O	62	I/O	NC	I/O	144	I/O	187	VCCIO
21	I/O	63	I/O	103	TRSTB	145	VCC	188	I/O
22	I/O	64	I/O	104	TMS	NC	I/O	NC	I/O
23	GND	NC	I/O	105	I/O	146	I/O	189	I/O
24	I/O	65	I/O	NC	I/O	147	GND	190	I/O
25	GCLK/I	66	I/O	106	I/O	148	I/O	191	I/O
26	GCLK/I	67	I/O	107	I/O	149	I/O	192	I/O
27	VCC	NC	I/O	108	I/O	150	I/O	193	I/O
28	GCLK/I	68	I/O	109	I/O	151	I/O	194	I/O
29	GCLK/I	69	I/O	NC	I/O	152	I/O	NC	I/O
30	VCC	70	I/O	110	I/O	153	I/O	195	I/O
31	I/O	NC	I/O	111	I/O	154	I/O	196	I/O
32	I/O	71	I/O	112	I/O	155	I/O	197	I/O
NC	GND	NC	I/O	113	I/O	156	I/O	198	I/O
33	I/O	72	I/O	114	VCC	157	TCK	NC	I/O
NC	I/O	73	GND	115	I/O	158	STM	199	GND
34	I/O	74	I/O	116	GND	NC	I/O	200	I/O
35	I/O	NC	VCC	117	I/O	159	I/O	201	VCC
36	I/O	75	I/O	NC	I/O	160	I/O	202	I/O
NC	I/O	76	I/O	118	I/O	161	I/O	203	I/O
37	I/O	77	I/O	119	I/O	162	I/O	204	I/O
38	I/O	78	GND	120	I/O	163	GND	205	I/O
39	I/O	79	I/O	121	I/O	164	I/O	206	I/O
NC	I/O	80	I/O	NC	I/O	165	VCC	207	TDO
40	I/O	81	I/O	122	I/O	166	I/O		
41	VCC	82	I/O	123	I/O	NC	I/O		
42	I/O	83	VCCIO	124	I/O	167	I/O		

456-PIN PBGA PINOUT DIAGRAM



TOP

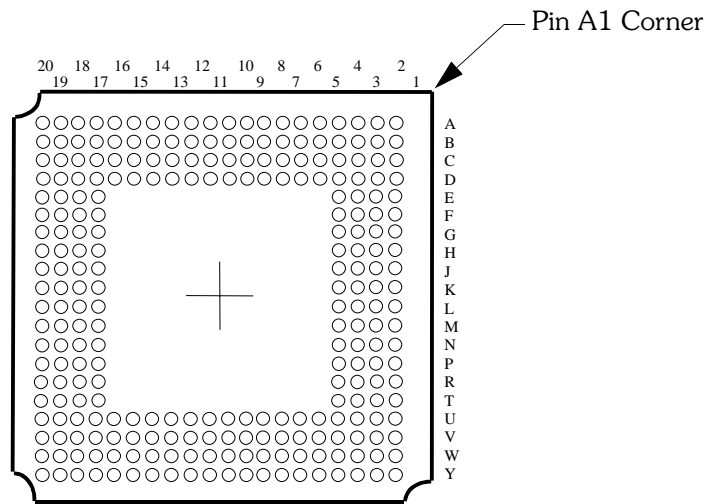

BOTTOM

QL3040 - pASIC 3 FPGATM

PBGA 456 PINOUT TABLE

456	Function	456	Function	456	Function	456	Function	456	Function
A1	I/O	B26	STM	D25	I/O	H4	I/O	M14	GND/THERM
A2	I/O	C1	I/O	D26	I/O	H5	NC	M15	GND/THERM
A3	I/O	C2	I/O	E1	I/O	H22	NC	M16	GND/THERM
A4	I/O	C3	I/O	E2	I/O	H23	NC	M22	NC
A5	I/O	C4	TDO	E3	I/O	H24	I/O	M23	NC
A6	I/O	C5	I/O	E4	I/O	H25	NC	M24	I/O
A7	I/O	C6	I/O	E5	GND	H26	I/O	M25	I/O
A8	I/O	C7	I/O	E6	VCC	J1	I/O	M26	I/O
A9	NC	C8	I/O	E7	GND	J2	I/O	N1	GCLK/I
A10	I/O	C9	I/O	E8	NC	J3	I/O	N2	I/O
A11	I/O	C10	I/O	E9	GND	J4	NC	N3	I/O
A12	VCCIO	C11	I/O	E10	I/O	J5	GND	N4	GCLK/I
A13	I/O	C12	I/O	E11	GND	J22	NC	N5	VCC
A14	I/O	C13	I/O	E12	GND	J23	NC	N11	GND/THERM
A15	NC	C14	I/O	E13	VCC	J24	I/O	N12	GND/THERM
A16	I/O	C15	I/O	E14	GND	J25	I/O	N13	GND/THERM
A17	NC	C16	I/O	E15	GND	J26	I/O	N14	GND/THERM
A18	I/O	C17	NC	E16	GND	K1	NC	N15	GND/THERM
A19	I/O	C18	NC	E17	NC	K2	NC	N16	GND/THERM
A20	I/O	C19	I/O	E18	GND	K3	I/O	N22	GND
A21	NC	C20	I/O	E19	NC	K4	I/O	N23	I/O
A22	I/O	C21	I/O	E20	GND	K5	VCC	N24	I/O
A23	NC	C22	I/O	E21	VCC	K22	GND	N25	NC
A24	I/O	C23	I/O	E22	GND	K23	I/O	N26	I/O
A25	I/O	C24	I/O	E23	I/O	K24	I/O	P1	I/O
A26	I/O	C25	TCK	E24	I/O	K25	NC	P2	I/O
B1	I/O	C26	NC	E25	I/O	K26	I/O	P3	NC
B2	NC	D1	I/O	E26	I/O	L1	I/O	P4	I/O
B3	I/O	D2	I/O	F1	I/O	L2	I/O	P5	NC
B4	NC	D3	I/O	F2	I/O	L3	I/O	P11	GND/THERM
B5	NC	D4	GND	F3	NC	L4	I/O	P12	GND/THERM
B6	NC	D5	NC	F4	NC	L5	NC	P13	GND/THERM
B7	NC	D6	NC	F5	VCC	L11	GND/THERM	P14	GND/THERM
B8	NC	D7	I/O	F22	VCC	L12	GND/THERM	P15	GND/THERM
B9	I/O	D8	I/O	F23	NC	L13	GND/THERM	P16	GND/THERM
B10	NC	D9	GND	F24	I/O	L14	GND/THERM	P22	NC
B11	NC	D10	I/O	F25	I/O	L15	GND/THERM	P23	GCLK / I
B12	I/O	D11	I/O	F26	I/O	L16	GND/THERM	P24	GCLK / I
B13	I/O	D12	GND	G1	I/O	L22	NC	P25	NC
B14	NC	D13	I/O	G2	I/O	L23	I/O	P26	ACLK / I
B15	I/O	D14	I/O	G3	I/O	L24	I/O	R1	NC
B16	I/O	D15	GND	G4	I/O	L25	NC	R2	I/O
B17	I/O	D16	I/O	G5	NC	L26	I/O	R3	I/O
B18	I/O	D17	I/O	G22	GND	M1	ACLK / I	R4	NC
B19	I/O	D18	GND	G23	NC	M2	GCLK/I	R5	NC
B20	I/O	D19	I/O	G24	I/O	M3	I/O	R11	GND/THERM
B21	I/O	D20	NC	G25	I/O	M4	NC	R12	GND/THERM
B22	I/O	D21	NC	G26	I/O	M5	GND	R13	GND/THERM
B23	NC	D22	I/O	H1	NC	M11	GND/THERM	R14	GND/THERM
B24	I/O	D23	GND	H2	I/O	M12	GND/THERM	R15	GND/THERM
B25	I/O	D24	I/O	H3	NC	M13	GND/THERM	R16	GND/THERM

(continued next page)

QL3040 - pASIC 3 FPGA™

PBGA 456 Pinout Table
(Continued from previous page)

456	Function	456	Function	456	Function	456	Function
R22	VCC	Y1	NC	AC6	NC	AE5	I/O
R23	NC	Y2	I/O	AC7	NC	AE6	I/O
R24	NC	Y3	NC	AC8	NC	AE7	I/O
R25	I/O	Y4	I/O	AC9	NC	AE8	I/O
R26	GCLK / I	Y5	I/O	AC10	NC	AE9	I/O
T1	I/O	Y22	GND	AC11	I/O	AE10	I/O
T2	I/O	Y23	I/O	AC12	NC	AE11	I/O
T3	I/O	Y24	NC	AC13	I/O	AE12	I/O
T4	I/O	Y25	I/O	AC14	VCCIO	AE13	I/O
T5	VCC	Y26	I/O	AC15	NC	AE14	I/O
T11	GND/THERM	AA1	I/O	AC16	NC	AE15	I/O
T12	GND/THERM	AA2	I/O	AC17	NC	AE16	I/O
T13	GND/THERM	AA3	NC	AC18	NC	AE17	I/O
T14	GND/THERM	AA4	NC	AC19	I/O	AE18	I/O
T15	GND/THERM	AA5	VCC	AC20	I/O	AE19	I/O
T16	GND/THERM	AA22	VCC	AC21	I/O	AE20	I/O
T22	GND	AA23	NC	AC22	NC	AE21	I/O
T23	I/O	AA24	I/O	AC23	GND	AE22	NC
T24	I/O	AA25	I/O	AC24	NC	AE23	NC
T25	NC	AA26	I/O	AC25	I/O	AE24	TMS
T26	I/O	AB1	NC	AC26	I/O	AE25	I/O
U1	NC	AB2	I/O	AD1	I/O	AE26	I/O
U2	I/O	AB3	I/O	AD2	NC	AF1	I/O
U3	I/O	AB4	I/O	AD3	I/O	AF2	NC
U4	I/O	AB5	GND	AD4	I/O	AF3	I/O
U5	GND	AB6	VCC	AD5	I/O	AF4	NC
U22	NC	AB7	NC	AD6	I/O	AF5	I/O
U23	I/O	AB8	NC	AD7	I/O	AF6	I/O
U24	I/O	AB9	NC	AD8	I/O	AF7	I/O
U25	I/O	AB10	VCC	AD9	NC	AF8	I/O
U26	I/O	AB11	GND	AD10	I/O	AF9	I/O
V1	I/O	AB12	NC	AD11	NC	AF10	I/O
V2	I/O	AB13	I/O	AD12	I/O	AF11	NC
V3	NC	AB14	GND	AD13	I/O	AF12	I/O
V4	NC	AB15	VCC	AD14	I/O	AF13	I/O
V5	NC	AB16	I/O	AD15	I/O	AF14	NC
V22	GND	AB17	NC	AD16	I/O	AF15	NC
V23	NC	AB18	VCC	AD17	I/O	AF16	I/O
V24	I/O	AB19	GND	AD18	I/O	AF17	I/O
V25	NC	AB20	NC	AD19	NC	AF18	I/O
V26	I/O	AB21	VCC	AD20	NC	AF19	NC
W1	I/O	AB22	GND	AD21	I/O	AF20	I/O
W2	I/O	AB23	I/O	AD22	I/O	AF21	I/O
W3	I/O	AB24	NC	AD23	TRSTB	AF22	I/O
W4	I/O	AB25	I/O	AD24	NC	AF23	I/O
W5	NC	AB26	I/O	AD25	I/O	AF24	I/O
W22	NC	AC1	I/O	AD26	I/O	AF25	I/O
W23	I/O	AC2	I/O	AE1	TDI	AF26	I/O
W24	I/O	AC3	NC	AE2	I/O		
W25	I/O	AC4	GND	AE3	I/O		
W26	NC	AC5	NC	AE4	I/O		

Note: NC pins must be left unconnected on printed circuit board.

QL3040 - pASIC 3 FPGA™

PIN DESCRIPTIONS

Pin	Function	Description
TDI	Test Data In for JTAG	Hold HIGH during normal operation. Connect to VCC if not used for JTAG.
TRSTB	Active low Reset for JTAG	Hold LOW during normal operation. Connect to ground if not used for JTAG.
TMS	Test Mode Select for JTAG	Hold HIGH during normal operation. Connect to VCC if not used for JTAG.
TCK	Test Clock for JTAG	Hold HIGH or LOW during normal operation. Connect to VCC or ground if not used for JTAG.
TDO	Test data out for JTAG	Output that must be left unconnected if not used for JTAG.
STM	Special Test Mode	Must be grounded during normal operation.
I/ACLK	High-drive input and/or array network driver	Can be configured as either or both.
I/GCLK	High-drive input and/or global network driver	Can be configured as either or both.
I	High-drive input	Use for input signals with high fanout.
I/O	Input/Output pin	Can be configured as an input and/or output.
VCC	Power supply pin	Connect to 3.3V supply.
VCCIO	Input voltage tolerance pin	Connect to 5.0 volt supply if 5 volt input tolerance is required, otherwise connect to 3.3V supply.
GND	Ground pin	Connect to ground.

Ordering Information

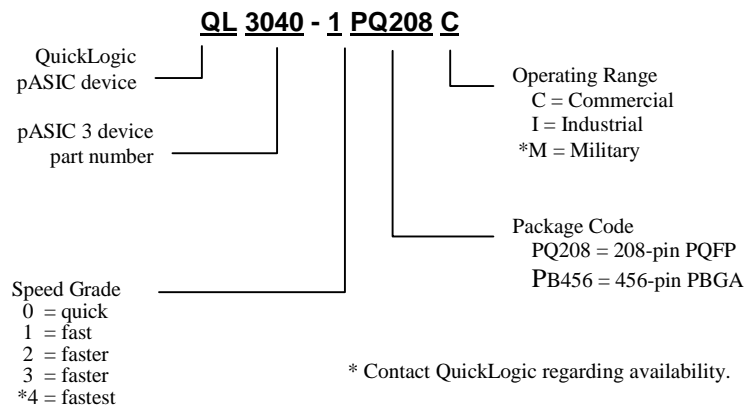

QL3040 - pASIC 3 FPGA™

Absolute Maximum Ratings

VCC Voltage	-0.5 to 4.6V	DC Input Current	±20 mA
VCCIO Voltage	-0.5 to 7.0V	ESD Pad Protection	±2000V
Input Voltage	-0.5 to VCCIO +0.5V	Storage Temperature	-65°C to +150°C
Latch-up Immunity	±200 mA	Lead Temperature	300°C

Operating Range

Symbol	Parameter	Military		Industrial		Commercial		Unit	
		Min	Max	Min	Max	Min	Max		
VCC	Supply Voltage	3.0	3.6	3.0	3.6	3.0	3.6	V	
VCCIO	I/O Input Tolerance Voltage	3.0	5.5	3.0	5.5	3.0	5.25	V	
TA	Ambient Temperature	-55		-40	85	0	70	°C	
TC	Case Temperature		125					°C	
K	Delay Factor	-0 Speed Grade			0.43	1.90	0.46	1.85	
		-1 Speed Grade	0.42	1.64	0.43	1.54	0.46	1.50	
		-2 Speed Grade	0.42	1.37	0.43	1.28	0.46	1.25	
		-3 Speed Grade	N/A	N/A	0.43	0.90	0.46	0.88	
		-4 Speed Grade	N/A	N/A	0.43	0.82	0.46	0.80	

DC Characteristics

Symbol	Parameter	Conditions	Min	Max	Unit
VIH	Input HIGH Voltage		0.5VCC	VCCIO+0.5	V
VIL	Input LOW Voltage		-0.5	0.3VCC	V
VOH	Output HIGH Voltage	IOH = -12 mA	2.4		V
		IOH = -500 µA	0.9VCC		V
VOL	Output LOW Voltage	IOL = 16 mA [1]		0.45	V
		IOL = 1.5 mA		0.1VCC	V
II	I or I/O Input Leakage Current	VI = VCCIO or GND	-10	10	µA
IOZ	3-State Output Leakage Current	VI = VCCIO or GND	-10	10	µA
CI	Input Capacitance [2]			10	pF
IOS	Output Short Circuit Current [3]	VO = GND	-15	-180	mA
		VO = VCC	40	210	mA
ICC	D.C. Supply Current [4]	VI, VIO = VCCIO or GND	0.50 (typ)	2	mA
ICCIO	D.C. Supply Current on VCCIO		0	100	µA

Notes:

- [1] Applies only to -1/-2/-3/-4 commercial grade devices. These speed grades are also PCI-compliant. All other devices have 8 mA IOL specifications.
- [2] Capacitance is sample tested only. Clock pins are 12 pF maximum.
- [3] Only one output at a time. Duration should not exceed 30 seconds.
- [4] For -1/-2/-3/-4 commercial grade devices only. Maximum ICC is 3 mA for -0 commercial grade and all industrial grade devices, and 5 mA for all military grade devices. For AC conditions, contact QuickLogic customer engineering.

QL3040 - pASIC 3 FPGA™

AC Characteristics at VCC = 3.3V, TA = 25°C (K = 1.00)

(To calculate delays, multiply the appropriate K factor in the "Operating Range" section by the following numbers.)

Logic Cells

Symbol	Parameter	Propagation Delays (ns) Fanout [5]				
		1	2	3	4	8
tPD	Combinatorial Delay [6]	1.4	1.7	1.9	2.2	3.2
tSU	Setup Time [6]	1.7	1.7	1.7	1.7	1.7
tH	Hold Time	0.0	0.0	0.0	0.0	0.0
tCLK	Clock to Q Delay	0.7	1.0	1.2	1.5	2.5
tCWHI	Clock High Time	1.2	1.2	1.2	1.2	1.2
tCWLO	Clock Low Time	1.2	1.2	1.2	1.2	1.2
tSET	Set Delay	1.0	1.3	1.5	1.8	2.8
tRESET	Reset Delay	0.8	1.1	1.3	1.6	2.6
tSW	Set Width	1.9	1.9	1.9	1.9	1.9
tRW	Reset Width	1.8	1.8	1.8	1.8	1.8

Input-Only/Clock Cells

Symbol	Parameter	Propagation Delays (ns) Fanout [5]						
		1	2	3	4	8	12	24
tIN	High Drive Input Delay	1.5	1.6	1.8	1.9	2.4	2.9	4.4
tINI	High Drive Input, Inverting Delay	1.6	1.7	1.9	2.0	2.5	3.0	4.5
tISU	Input Register Set-Up Time	3.1	3.1	3.1	3.1	3.1	3.1	3.1
tIH	Input Register Hold Time	0.0	0.0	0.0	0.0	0.0	0.0	0.0
tICLK	Input Register Clock To Q	0.7	0.8	1.0	1.1	1.6	2.1	3.6
tIRST	Input Register Reset Delay	0.6	0.7	0.9	1.0	1.5	2.0	3.5
tIESU	Input Register clock Enable Set-Up Time	2.3	2.3	2.3	2.3	2.3	2.3	2.3
tIEH	Input Register Clock Enable Hold Time	0.0	0.0	0.0	0.0	0.0	0.0	0.0

Notes:

[5] Stated timing for worst case Propagation Delay over process variation at VCC=3.3V and TA=25°C. Multiply by the appropriate Delay Factor, K, for speed grade, voltage and temperature settings as specified in the Operating Range.

[6] These limits are derived from a representative selection of the slowest paths through the pASIC 3 logic cell including typical net delays. Worst case delay values for specific paths should be determined from timing analysis of your particular design.

QL3040 - pASIC 3 FPGA™

Clock Cells

Symbol	Parameter	Propagation Delays (ns) Loads per Half Column [7]						
		1	2	3	4	8	10	11
tACK	Array Clock Delay	1.2	1.2	1.3	1.3	1.5	1.6	1.7
tGCKP	Global Clock Pin Delay	0.7	0.7	0.7	0.7	0.7	0.7	0.7
tGCKB	Global Clock Buffer Delay	0.8	0.8	0.9	0.9	1.1	1.2	1.3

I/O Cells

Symbol	Parameter	Propagation Delays (ns) Fanout [5]					
		1	2	3	4	8	10
tI/O	Input Delay (bidirectional pad)	1.3	1.6	1.8	2.1	3.1	3.6
tISU	Input Register Set-Up Time	3.1	3.1	3.1	3.1	3.1	3.1
tIH	Input Register Hold Time	0.0	0.0	0.0	0.0	0.0	0.0
tIOCLK	Input Register Clock To Q	0.7	1.0	1.2	1.5	2.5	3.0
tIORST	Input Register Reset Delay	0.6	0.9	1.1	1.4	2.4	2.9
tIESU	Input Register clock Enable Set-Up Time	2.3	2.3	2.3	2.3	2.3	2.3
tIEH	Input Register Clock Enable Hold Time	0.0	0.0	0.0	0.0	0.0	0.0

Symbol	Parameter	Propagation Delays (ns) Output Load Capacitance (pF)				
		30	50	75	100	150
tOUTLH	Output Delay Low to High	2.1	2.5	3.1	3.6	4.7
tOUTHHL	Output Delay High to Low	2.2	2.6	3.2	3.7	4.8
tPZH	Output Delay Tri-state to High	1.2	1.7	2.2	2.8	3.9
tPZL	Output Delay Tri-state to Low	1.6	2.0	2.6	3.1	4.2
tPHZ	Output Delay High to Tri-State [8]	2.0				
tPLZ	Output Delay Low to Tri-State [8]	1.2				

Notes:

[7] The array distributed networks consist of 40 half columns and the global distributed networks consist of 44 half columns, each driven by an independent buffer. The number of half columns used does not affect clock buffer delay. The array clock has up to 8 loads per half column. The global clock has up to 11 loads per half column.

[8] The following loads are used for tPXZ:

