

NTC Thermistor for Automotive: TSM-C Series



SMD NTC Thermistor for Temperature Sensing

■ Features

1. Qualification based on AEC-Q200 Rev-C
2. Operating temperature range: -50 ~ +150 °C
3. Superior stability in high-temperature and high-humidity environment
4. RoHS compliant



■ Recommended Applications

1. Car audio, car navigation
2. Various engine control units
3. Circuits for ETC equipment
4. Various motor driving circuits
5. Temperature compensation for various circuits

■ Part Number Code

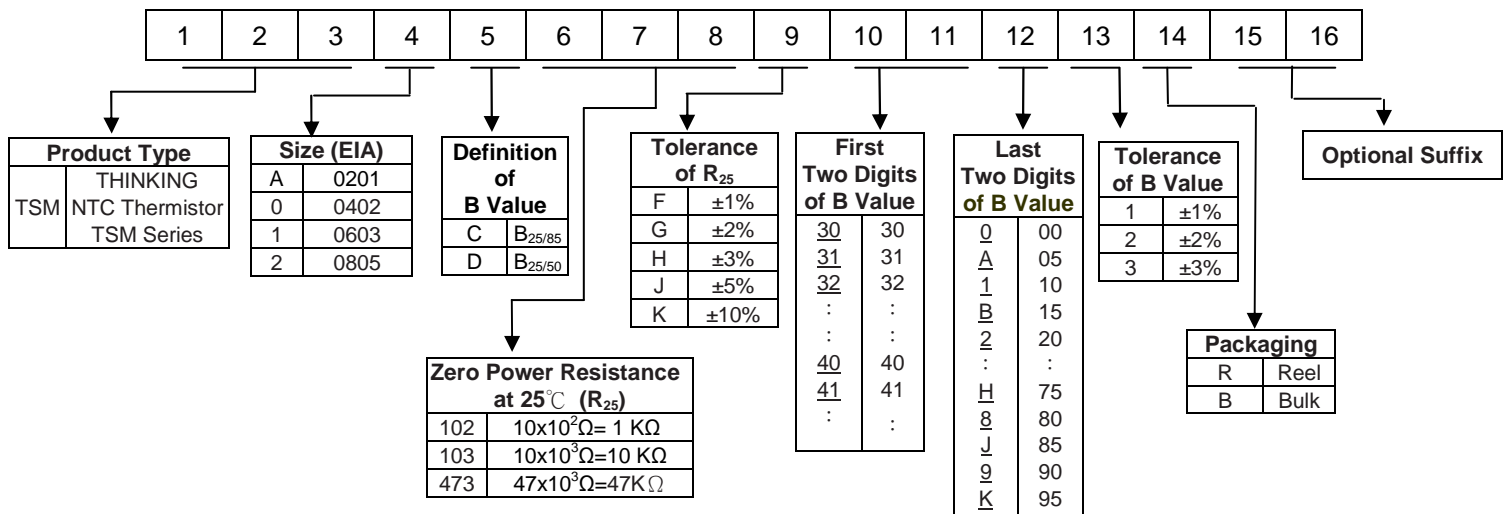

■ Structure and Dimensions

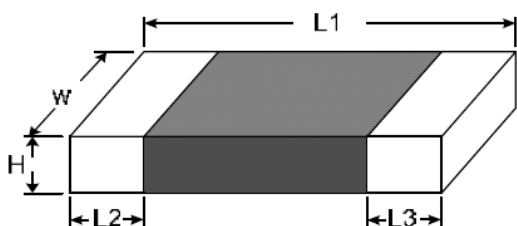

(Unit: mm)

Part No.	Size	L1.	W	H max.	L2 & L3
TSM1	0603	1.60±0.15	0.80±0.15	0.95	0.40±0.15
TSM2	0805	2.00±0.20	1.25±0.20	1.20	0.40±0.20

■ Electrical Characteristics

Part No.	Zero Power Resistance at 25°C	Tolerance of R ₂₅	B Value		Tolerance of B value	Max. Power Dissipation at 25°C	Dissipation Factor	Thermal Time Constant	Operating Temperature Range
	R ₂₅ (KΩ)	(±%)	(K)		(±%)	P _{max} (mW)	δ(mW/°C)	τ(Sec.)	T _L ~T _U (°C)
TSM1C103F34D3R	10	1 · 2 · 3	25/85	3435	3	210	Approx. 2.1	Approx. 3.1	-50 ~ +150
TSM1C103F39H3R	10		25/85	3975					
TSM1C473F39H3R	47		25/85	3975					
TSM2C103F34D3R	10	1 · 2 · 3	25/85	3435	3	240	Approx. 2.4	Approx. 5.4	-50 ~ +150
TSM2C103F39H3R	10		25/85	3975					
TSM2C473F39H3R	47		25/85	3975					

Note 1: □ = Tolerance of R₂₅

*Special specifications are available upon request

■ Max. Power Dissipation Derating Curve

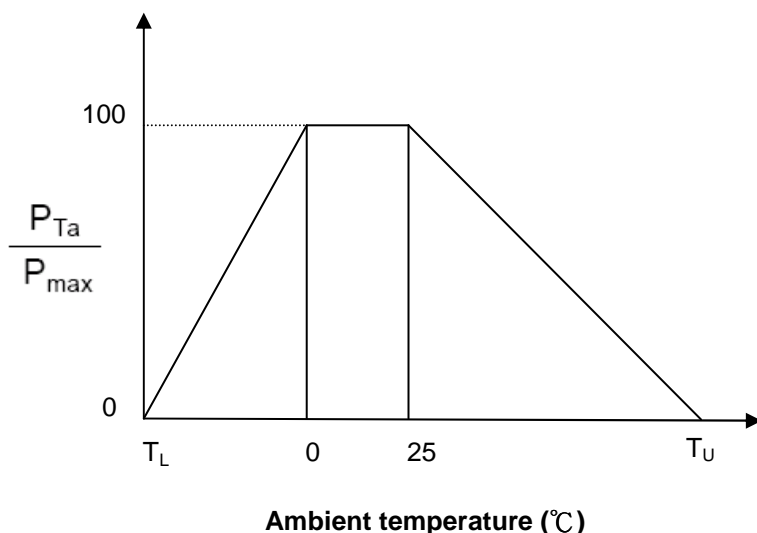

T_U : Maximum operating temperature (°C)

T_L : Minimum operating temperature (°C)

For example :

Ambient temperature (T_a)=55°C

Maximum operating temperature (T_U)=150°C

$P_{Ta} = (T_U - T_a) / (T_U - 25) \times P_{max} = 76\% P_{max}$

NTC Thermistor for Automotive: TSM-C Series

SMD NTC Thermistor for Temperature Sensing



■ R-T Characteristic Curves (representative)

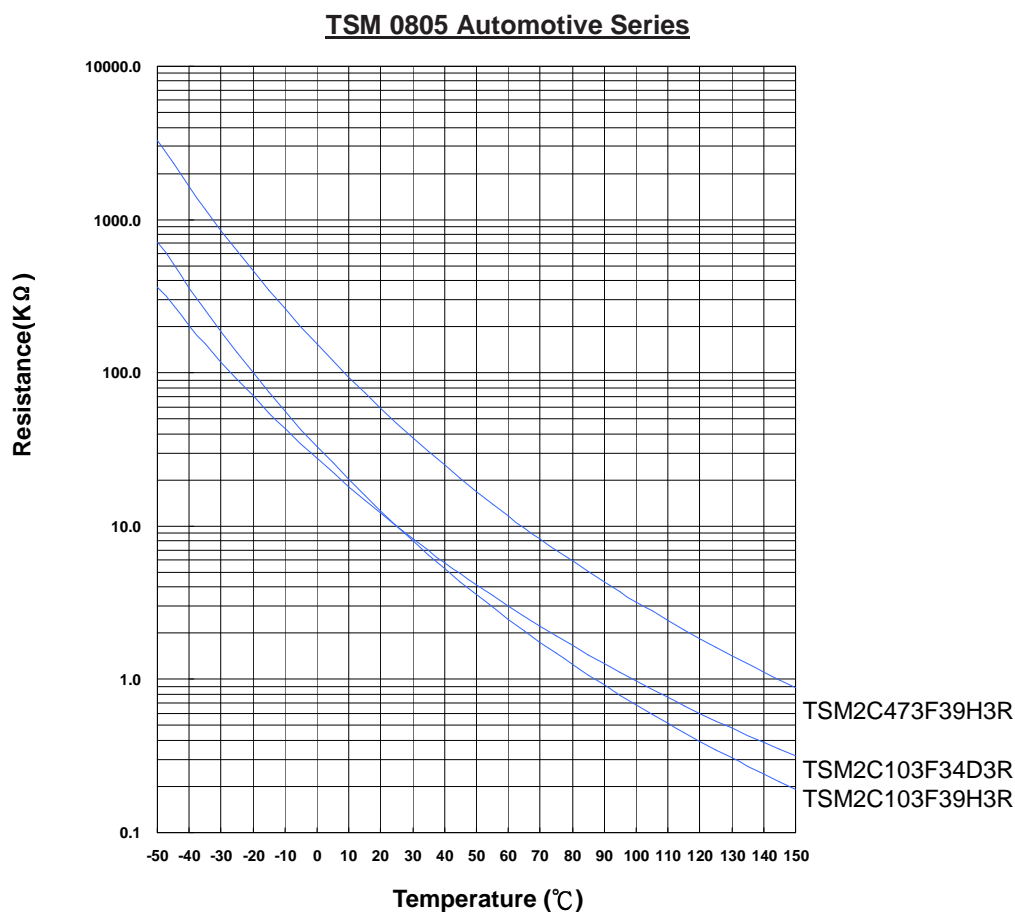
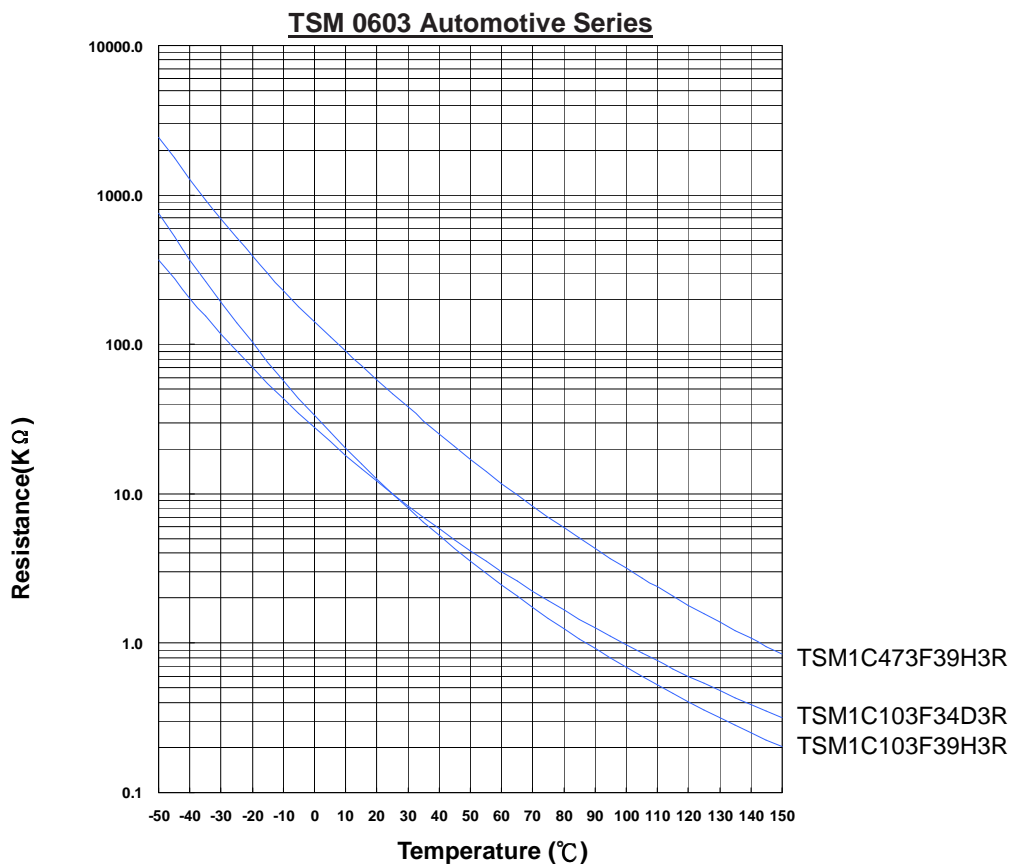

NTC Thermistor for Automotive: TSM-C Series

SMD NTC Thermistor for Temperature Sensing



■ Soldering Recommendation

● IR-reflow Soldering Profile

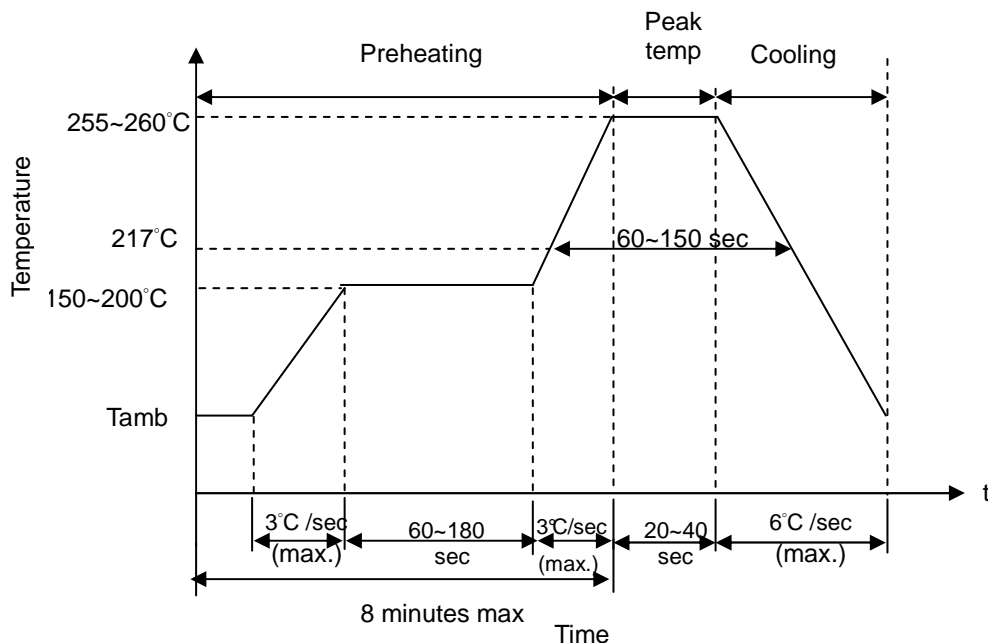

● Reworking Conditions with Soldering Iron

Item	Conditions
Temperature of Soldering Iron-tip	360°C (max.)
Soldering Time	3 sec (max.)
Diameter of Soldering Iron-tip	Φ3mm (max.)

Caution: Do not touch the component surface with soldering iron directly to prevent it from damage.

■ Recommended Soldering Pad Dimensions

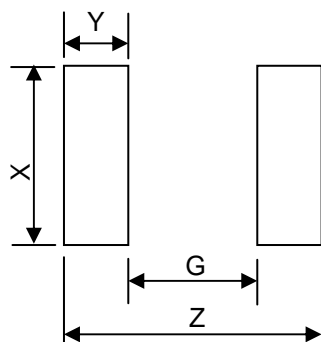

Size	Z (mm)	G (mm)	X (mm)	Y (mm)
0603	3.0	1.0	1.0	1.0
0805	3.4	1.0	1.4	1.2

NTC Thermistor for Automotive: TSM-C Series

SMD NTC Thermistor for Temperature Sensing



Reliability (based on AEC-Q200 Rev-C)

Item	Standard	Test conditions / Methods	Specifications																																										
High Temperature Exposure (Storage)	MIL-STD-202 Method 108	Test temp. : 150 +3/-0°C Duration: 1000 h Unpowered Measurement at 24±2 hours after test conclusion.	No visible damage $ \Delta R_{25}/R_{25} \leq 5\%$																																										
Temperature Cycling	JESD22 Method JA-104	Lower test temp. : -55 +0/-3°C Upper test temp. : 150 +3/-0°C Soak Time at Lower or Upper Temperature : 1 min Cycle time : 2 Cycles/hr Number of cycles : 1000 Measurement at 24±2 hours after test conclusion.	No visible damage $ \Delta R_{25}/R_{25} \leq 5\%$																																										
Moisture Resistance	MIL-STD-202 Method 106	Duration of 1 cycle: 24 h Number of cycles: 10 , Unpowered Measurement at 24±2 hours after test conclusion. <table border="1" style="margin: 10px auto;"> <thead> <tr> <th rowspan="2">Step</th> <th colspan="2">Temp.</th> <th rowspan="2">humidity (%)</th> <th rowspan="2">Period (hr)</th> </tr> <tr> <th>Start</th> <th>Finish</th> </tr> </thead> <tbody> <tr> <td>1</td> <td>25</td> <td>65</td> <td>90~100</td> <td>2.5</td> </tr> <tr> <td>2</td> <td>65</td> <td>65</td> <td>90~100</td> <td>3</td> </tr> <tr> <td>3</td> <td>65</td> <td>25</td> <td>80~100</td> <td>2.5</td> </tr> <tr> <td>4</td> <td>25</td> <td>65</td> <td>90~100</td> <td>2.5</td> </tr> <tr> <td>5</td> <td>65</td> <td>65</td> <td>90~100</td> <td>3</td> </tr> <tr> <td>6</td> <td>65</td> <td>25</td> <td>80~100</td> <td>2.5</td> </tr> <tr> <td>7</td> <td>25</td> <td>25</td> <td>80~100</td> <td>8</td> </tr> </tbody> </table>	Step	Temp.		humidity (%)	Period (hr)	Start	Finish	1	25	65	90~100	2.5	2	65	65	90~100	3	3	65	25	80~100	2.5	4	25	65	90~100	2.5	5	65	65	90~100	3	6	65	25	80~100	2.5	7	25	25	80~100	8	No visible damage $ \Delta R_{25}/R_{25} \leq 5\%$
Step	Temp.			humidity (%)	Period (hr)																																								
	Start	Finish																																											
1	25	65	90~100	2.5																																									
2	65	65	90~100	3																																									
3	65	25	80~100	2.5																																									
4	25	65	90~100	2.5																																									
5	65	65	90~100	3																																									
6	65	25	80~100	2.5																																									
7	25	25	80~100	8																																									
Biased Humidity	MIL-STD-202 Method 103	Test temp. : 85°C Rel. humidity of air : 85% Duration: 1000 h 10% Rated Power. Measurement at 24±2 hours after test conclusion.	No visible damage $ \Delta R_{25}/R_{25} \leq 5\%$																																										

NTC Thermistor for Automotive: TSM-C Series



SMD NTC Thermistor for Temperature Sensing

Item	Standard	Test conditions / Methods	Specifications
Operational Life	MIL-STD-202 Method 108	Test temp.: 150 +3/-0°C Duration: 1000 h Test Power : 1mW Measurement at 24±2 hours after test conclusion.	No visible damage $ \Delta R_{25}/R_{25} \leq 5\%$
External Visual	MIL-STD-883 Method 2009	Inspect device construction, marking and workmanship.	No visible damage
Physical Dimension	JESD22 Method JB-100	Verify physical dimensions to the applicable device specification.	Within the specified values
Resistance to Solvents	MIL-STD-202 Method 215	Per MIL-STD-202 Method 215 Solvent 1: 1 part (by volume) of isopropyl alcohol 3 part (by volume) of mineral spirits.	No visible damage
Mechanical Shock	MIL-STD -202-213	Test Condition F Peak value : 1500g's Half sine Waveform Normal duration (D) : 0.5ms In 3 directions perpendicularly intersecting each other (total 18 times).	No visible damage $ \Delta R_{25}/R_{25} \leq 5\%$
Vibration	MIL-STD-202 Method 204	Acceleration : 5 g's Sweep time: 20 min Frequency range: 10 to 2000 Hz 3×12 cycles	No visible damage $ \Delta R_{25}/R_{25} \leq 5\%$
Resistance to Soldering Heat	MIL-STD-202 Method 210	Condition B No pre-heat of samples. Temperature : 260±5°C, Time : 10±1s Immersion and emersion rate : 25mm/s ±6 mm/s Number of heat cycles : 1	No visible damage $ \Delta R_{25}/R_{25} \leq 5\%$
Thermal Shock	MIL-STD-202 Method 107	Lower test temp. : -55 +0/-3°C Upper test temp. : 150 +3/-0°C Maximum transfer time : 20 seconds. Dwell time : 15 minutes. Air-Air. Number of cycles : 300	No visible damage $ \Delta R_{25}/R_{25} \leq 5\%$

NTC Thermistor for Automotive: TSM-C Series



SMD NTC Thermistor for Temperature Sensing

Item	Standard	Test conditions / Methods	Specifications
ESD	AEC-Q200 -002	Discharge capacitance : 150 pF Charging voltage: 6 kV Contact discharge 1 pulse in each polarity	No visible damage $ \Delta R_{25}/R_{25} \leq 5\%$
Solderability	J-STD-002	a) 4 h @ 155°C dry heat Dip @235±5°C 5 +0/-0.5sec b) Steam aging 8 h±15min @93±3°C Dip @260±5°C 7±0.5sec	95% of termination wetted
Electrical Characterization	Specifications	R(-50°C) 、 R(25°C) 、 R(150°C) B(R25°C/R85°C)	Within the specified values
Board Flex	AEC-Q200 -005 (JIS-C-6429)	Bend the board : 2mm (Min.) Duration of the applied forces : 60 (+5) Sec	No visible damage $ \Delta R_{25}/R_{25} \leq 5\%$
Terminal Strength	AEC-Q200 -006 (JIS-C-6429)	Apply force : 0603=1.0kg (10 N) 0805=1.8kg (17.7 N) Duration of the applied forces : 60 (+1) Sec	No visible damage $ \Delta R_{25}/R_{25} \leq 5\%$

SMD NTC Thermistor for Temperature Sensing

■ Package

● Taping Specification

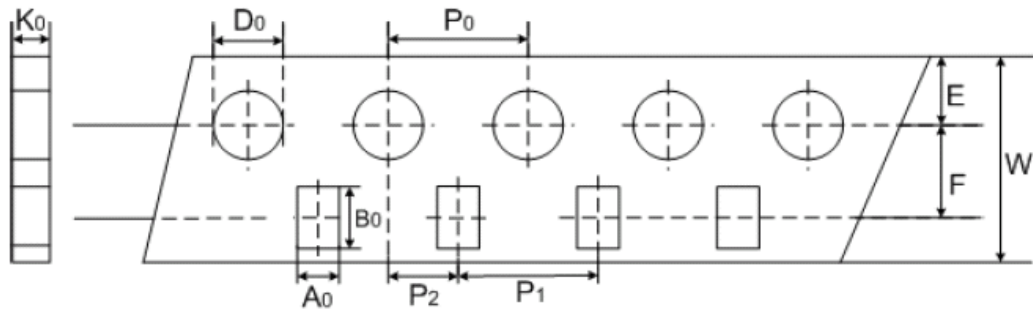

(Unit: mm)

Index Type	A_0	B_0	W	E	F	P_1	P_2	P_0	D_0	K_0
0603	± 0.2	± 0.2	± 0.2	± 0.1	± 0.05	± 0.1	± 0.05	± 0.1	± 0.1	± 0.1
0805	1.5	2.3	8	1.75	3.5	4	2	4	1.55	0.95

■ Quantity

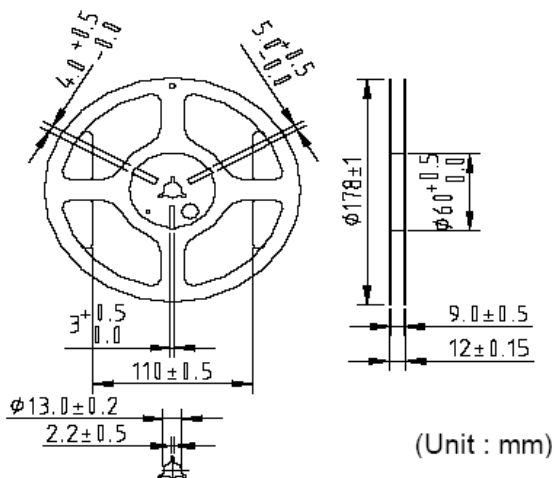

(Unit : mm)

Type	Quantity (pcs/reel)
0603	4,000
0805	3,500

■ Storage Conditions of Products

● Storage Conditions :

1. Storage Temperature: $-10^{\circ}\text{C} \sim +40^{\circ}\text{C}$
2. Relative Humidity: $\leq 75\% \text{RH}$
3. Keep away from corrosive atmosphere and sunlight.

● Shelf Life : 1 year