

CRYSTAL CONTROLLED OSCILLATORS

SURFACE MOUNT 3.3V HCMOS CLOCK OSCILLATOR



FSLD52TE

ABSOLUTE MAXIMUM RATINGS

TABLE 1.0

PARAMETER	UNITS	MINIMUM	NOMINAL	MAXIMUM	UNITS	NOTE
Storage Temperature		-40	-	85	°C	
Supply Voltage	(Vcc)	-0.5	-	7.0	Vdc	
Input Voltage	(Vc)	-0.5	-	7.0	Vdc	

OPERATING SPECIFICATIONS

TABLE 2.0

PARAMETER		MINIMUM	NOMINAL	MAXIMUM	UNITS	NOTE
Center Frequency	(Fo)	19.44	-	167	MHz	
Total Frequency Tolerance		-50	-	50	ppm	1
Operating Temperature Range		0	-	70	°C	
Supply Voltage	(Vcc)	3.0	3.3	3.6	Vdc	
Supply Current 2 to 31.999 MHz	(Icc)	-	-	50	mA	
Jitter (BW=10Hz to 20MHz)		-	-	5	pS rms	
Jitter (BW=12kHz to 20MHz)		-	-	1	pS rms	
SSB Phase Noise at 10Hz offset		-	-75	-	dBc/Hz	
SSB Phase Noise at 100Hz offset		-	-100	-	dBc/Hz	
SSB Phase Noise at 1KHz offset		-	-125	-	dBc/Hz	
SSB Phase Noise at 10KHz offset		-	-135	-	dBc/Hz	
SSB Phase Noise at 100KHz offset		-	-140	-	dBc/Hz	

INPUT CHARACTERISTICS

TABLE 3.0

PARAMETER		MINIMUM	NOMINAL	MAXIMUM	UNITS	NOTE
Enable Voltage	(Vih)	2.0	-	-	Vdc	2
Disable Voltage	(Vil)	-	-	0.5	Vdc	2

HCMOS OUTPUT CHARACTERISTICS

TABLE 4.0

PARAMETER		MINIMUM	NOMINAL	MAXIMUM	UNITS	NOTE
LOAD		-	-	50	pF	
Voltage (High)	(Voh)	Vcc-0.5V	-	-	Vdc	
(Low)	(Vol)	-	-	0.4	Vdc	
Current (High)	(Ioh)	-24	-	-	mA	
(Low)	(Iol)	-	-	24	mA	
Duty Cycle at 50% of Vcc		45	50	55	%	
Rise / Fall Time 10% to 90%		-	-	1.5	nS	
Start Up Time		-	-	10	mS	

PACKAGE CHARACTERISTICS

TABLE 5.0

Package	Non-hermetic package consisting of an FR4 substrate with grounded metal cover.
---------	--

PROCESS RECOMMENDATIONS

TABLE 6.0

Solder Reflow	The component solder used internal to this device has a melting point of 221°C. The peak temperature inside the device should be less than or equal to 220°C for a maximum of 10 seconds
Wash	Ultrasonic cleaning is not recommended.

Notes

- 1.0 Inclusive of calibration frequency at 25°C, frequency vs. temperature stability, supply voltage change, load change, shock and vibration and aging for ten years.
- 2.0 Oscillator output is enabled with no connection on pad 1

DESCRIPTION

The Connor-Winfield FSLD52TE is a surface mount 3.3V fixed frequency Crystal Controlled Oscillator (XO) with an HCMOS Tri-State output. The FSLD52TE is designed for applications requiring low jitter and tight frequency stability.

FEATURES

- 3.3V OPERATION
- OVERALL FREQUENCY TOLERANCE: ±50ppm
- TEMPERATURE RANGE: 0°C to 70°C
- LOW JITTER <1pS RMS
- TRI-STATE ENABLE/DISABLE FUNCTION
- SURFACE MOUNT PACKAGE
- TAPE AND REEL PACKAGING

ORDERING INFORMATION

FSLD52TE - 156.25 MHz

CLOCK SERIES

CENTER FREQUENCY

Specifications subject to change without notice.

CRYSTAL CONTROLLED OSCILLATORS

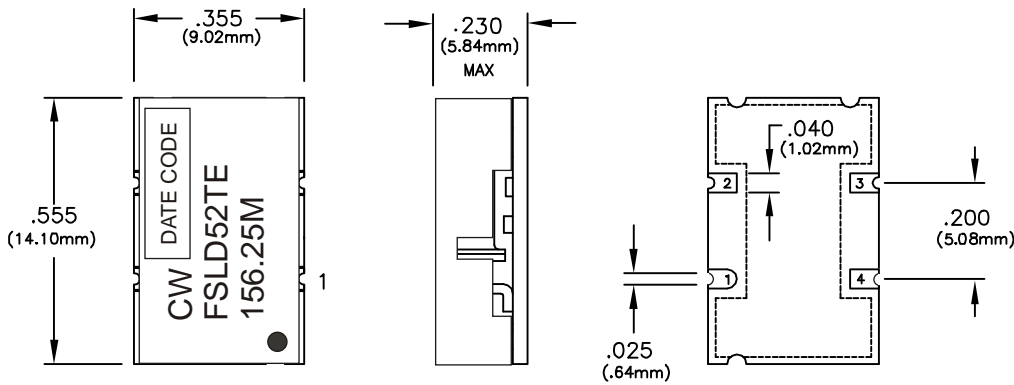

Pin	Connection
1	Enable/Disable
2	Ground
3	Output
4	Vcc

Dimensional Tolerance:  
±.005 (.127mm)

OUTPUT WAVEFORM

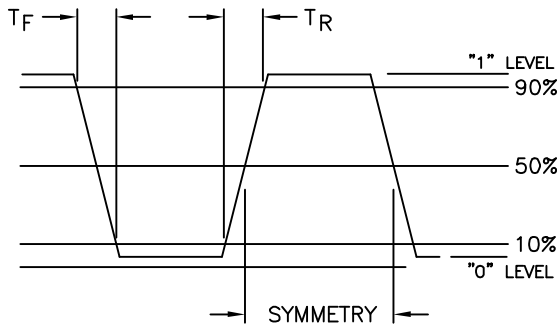

SUGGESTED PAD LAYOUT

(TOP VIEW)

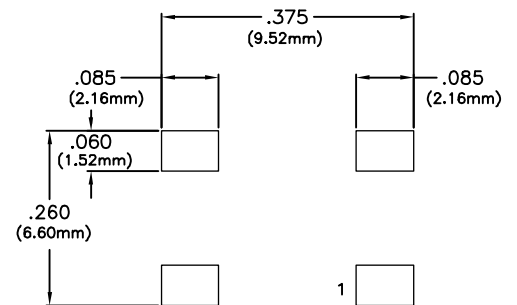

TEST CIRCUIT

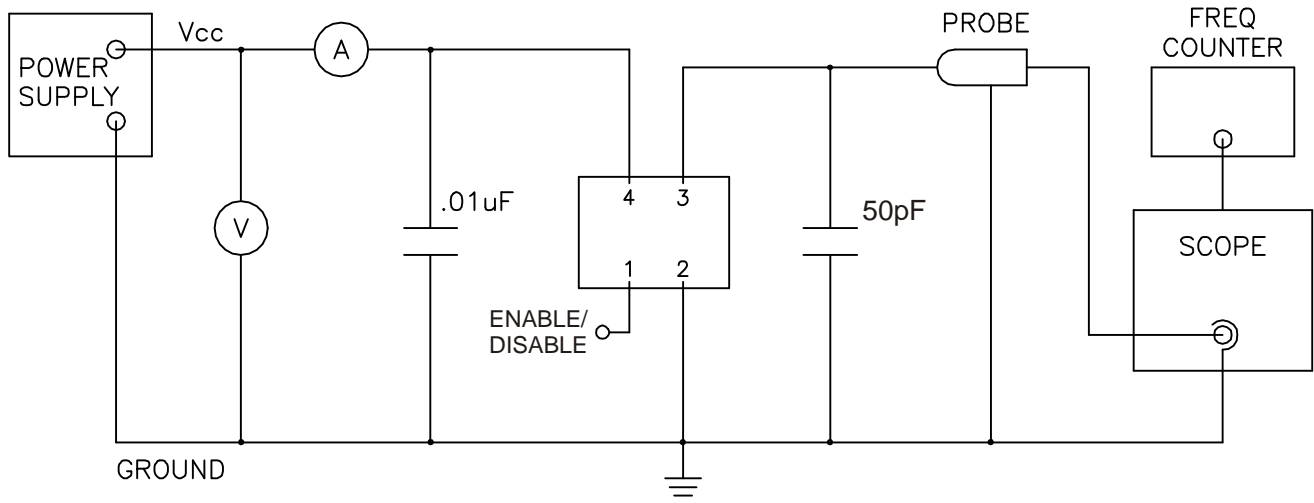

Specifications subject to change without notice.