

PLEASE CHECK WWW.MOLEX.COM FOR LATEST PART INFORMATION

Part Number: [0039302047](#)
Status: **Active**
Overview: [minifit_jr](#)
Description: 4.20mm (.165") Pitch Mini-Fit Jr.™ Header, Single Row, Vertical, with Snap-in Plastic Peg PCB Lock, 4 Circuits, PA Polyamide Nylon 6/6, UL 94V-2, 0.76µm (30µ") Gold (Au) Selective Plating, with Drain Holes

Documents:

[3D Model](#) [Product Specification PS-5556-001 \(PDF\)](#)
[Drawing \(PDF\)](#) [RoHS Certificate of Compliance \(PDF\)](#)

Agency Certification

CSA	LR19980
TUV	R72081037
UL	E29179

General

Product Family	PCB Headers
Series	5566
Application	Wire-to-Board
Comments	Current = 13A max. per circuit when header is mated to a receptacle loaded with 45750 Mini-Fit Plus HCS™ Crimp Terminal Crimped to to 16 AWG wire. . See Molex product specification PS-45750-001 for additional current de-rating information.. High Temperature, Square Pin, Solder Type
Overview	minifit_jr
Product Name	Mini-Fit Jr.™

Physical

Breakaway	No
Circuits (Loaded)	4
Circuits (maximum)	4
Color - Resin	Natural
Durability (mating cycles max)	30
First Mate / Last Break	No
Flammability	94V-2
Glow-Wire Compliant	No
Guide to Mating Part	No
Keying to Mating Part	None
Lock to Mating Part	Yes
Material - Metal	Brass
Material - Plating Mating	Gold
Material - Plating Termination	Tin
Material - Resin	Nylon
Number of Rows	1
Orientation	Vertical
PC Tail Length (in)	0.138 In
PC Tail Length (mm)	3.50 mm
PCB Locator	Yes
PCB Retention	Yes
PCB Thickness Recommended (in)	0.062 In
PCB Thickness Recommended (mm)	1.60 mm
Packaging Type	Tray
Pitch - Mating Interface (in)	0.165 In
Pitch - Mating Interface (mm)	4.20 mm

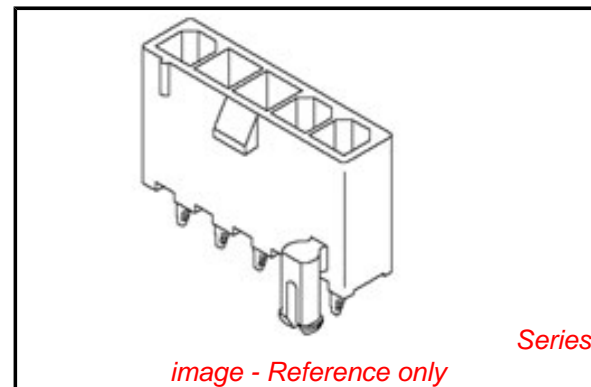

image - Reference only

EU RoHS

ELV and RoHS Compliant
REACH SVHC Contains SVHC: No
Halogen-Free Status
Not Reviewed

China RoHS



Need more information on product environmental compliance?

Email productcompliance@molex.com
 For a multiple part number RoHS Certificate of Compliance, [click here](#)

Please visit the [Contact Us](#) section for any non-product compliance questions.

Search Parts in this Series

[5566Series](#)

Mates With

[5557](#) Mini-Fit Jr.™ Receptacle Housing

Pitch - Term. Interface (in)	0.165 In
Pitch - Term. Interface (mm)	4.20 mm
Plating min: Mating (µin)	30.4
Plating min: Mating (µm)	0.76
Plating min: Termination (µin)	101.6
Plating min: Termination (µm)	2.54
Polarized to Mating Part	Yes
Polarized to PCB	Yes
Shrouded	Fully
Stackable	No
Surface Mount Compatible (SMC)	No
Temperature Range - Operating	-40°C to +105°C
Termination Interface: Style	Through Hole

Electrical

Current - Maximum per Contact	13A
Voltage - Maximum	600V

Solder Process Data

Duration at Max. Process Temperature (seconds)	5
Lead-free Process Capability	Wave Capable (TH only)
Max. Cycles at Max. Process Temperature	1
Process Temperature max. C	240

Material Info

Old Part Number	5566-04B3GS
-----------------	-------------

Reference - Drawing Numbers

Packaging Specification	PK-5566-002
Product Specification	PS-5556-001
Sales Drawing	SDA-5566-NL*
Test Summary	TS-5556-002

This document was generated on 05/21/2010

PLEASE CHECK WWW.MOLEX.COM FOR LATEST PART INFORMATION

NOTES:

1. MATERIALS:

HOUSING:

BLANK=NYLON 6/6, UL94 V-2, COLOR: NATURAL

210=NYLON 6/6, UL94 V-0, COLOR: NATURAL

BL=NYLON 6/6, UL94 V-2, COLOR: BLACK

TERMINALS:

BRASS

2. TERMINAL PLATING:

BLANK=.000035/(0.00090) MIN. BRIGHT TIN OVER

.000020/(0.00050) MIN. COPPER

*GS2=.000015/(0.00038) MIN. SELECT GOLD AND

.000100/(0.00254) MIN. SELECT MATTE TIN

OVER .000050/(0.00127) MIN. NICKEL OVERALL

*GS=.000030/(0.00076) MIN. SELECT GOLD AND

.000100/(0.00254) MIN. SELECT MATTE TIN

OVER .000050/(0.00127) MIN. NICKEL OVERALL

S=.000100/(0.00254) MIN. BRIGHT TIN OVER

.000050/(0.00127) MIN. NICKEL

*THE PRIMARY SHIPPING CARTON WILL BE LABELED

"ELV AND RoHS COMPLIANT", CARTONS WITHOUT

THIS LABEL MAY CONTAIN PRODUCT WITH

TIN-LEAD PLATING.

3. PRODUCT SPECIFICATION: PS-5566-001

4. PACKAGING: TRAY PACKED PER PK-5566-002

5. PART MATES WITH MINI-FIT JR. RECEPTACLE NO. 5557.

6. PART IS NOT DESIGNED FOR CURRENT SHARING.

7. PARTS ARE NOT TO BE MATED OR UN-MATED WHILE

CIRCUITS ARE LIVE.

8. PART CONFORMS TO CLASS "B" REQUIREMENTS OF

COSMETIC SPECIFICATION PS-45499-002.

CKT SIZE	DIM A	DIM B
4	.709 (18.00)	.496 (12.60)
5	.874 (22.20)	.661 (16.80)
6	1.039 (26.40)	.827 (21.00)
7	1.205 (30.60)	.992 (25.20)
8	1.370 (34.80)	1.157 (29.40)
9	1.535 (39.00)	1.323 (33.60)
10	1.701 (43.20)	1.488 (37.80)
11	1.866 (47.40)	1.654 (42.00)
12	2.031 (51.60)	1.819 (46.20)

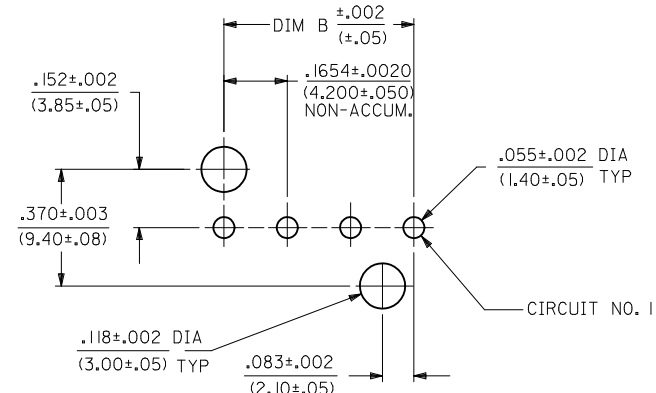
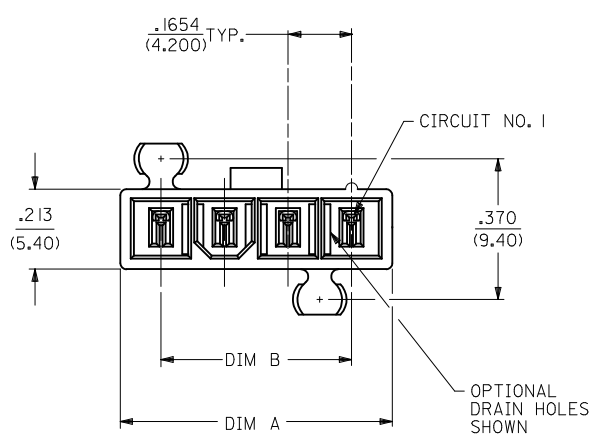
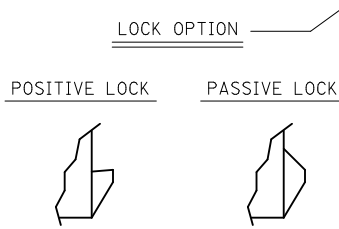
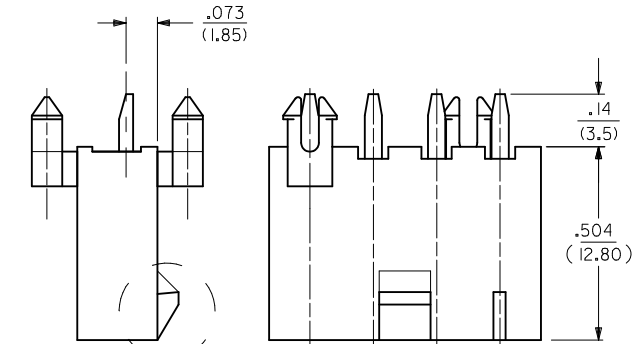
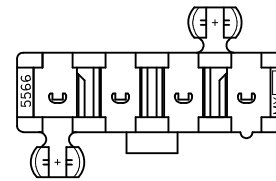

RECOMMENDED HOLE LAYOUT FOR
.070/(1.78) MAX. THICK P. C. BOARD
VIEWED FROM COMPONENT SIDE

LEGEND:

5566 - N * * * * *

CIRCUIT SIZE (04-12)

ASSEMBLY TYPE
A=W/O DRAIN HOLES
B=WITH DRAIN HOLES

PEG AND LOCK OPTION
3=MTG. PEGS, POSITIVE LOCK
4=MTG. PEGS, PASSIVE LOCK

PLATING (SEE NOTE 2)

HOUSING MAT'L (SEE NOTE 1)

4	M
3	M
2	K1
1	M
SHEET REV	

ADD PART #S EC NO: UCP2010-1922 DRWN: RBENES 2009/02/10 CHKD: BELL 2010/02/12 APPR: FSMITH 2010/02/15	QUALITY SYMBOLS ▽=0 ▽=0	GENERAL TOLERANCES (UNLESS SPECIFIED)	DIMENSION STYLE IN/MM	SCALE 1:1	DESIGN UNITS METRIC	THIRD ANGLE PROJECTION
		4 PLACES ± --- ± --- 3 PLACES ± --- ± .015 2 PLACES ± 0.38 ± --- 1 PLACE ± --- ± --- ANGULAR ± 1/2°	DRAWN BY KSS DATE 1989/02/19	CHECKED BY JTR DATE 1989/02/19	APPROVED BY RAS DATE 1989/02/19	TITLE VERTICAL HEADER ASSY W/ & W/O PEG & DRAIN HOLE MINI-FIT JR SINGLE ROW
MATERIAL NO. SEE CHART	DOCUMENT NO. SDA-5566-NL*	MOLEX INCORPORATED				
DRAFT WHERE APPLICABLE MUST REMAIN WITHIN DIMENSIONS		SIZE C	THIS DRAWING CONTAINS INFORMATION THAT IS PROPRIETARY TO MOLEX INCORPORATED AND SHOULD NOT BE USED WITHOUT WRITTEN PERMISSION			

13	12	11	10	9	8	7
PASSIVE LOCK WITH MTC, PEGS, 94V-2 HOUSING MATERIAL						
PART NO	ENG NO	CKT DRAIN SIZE/HOLE	PLATING OPTION			
NO E.D.P.	5566-04B4	4 YES	TIN OVER COPPER			
NO E.D.P.	5566-05B4	5 YES	TIN OVER COPPER			
NO E.D.P.	5566-06B4	6 YES	TIN OVER COPPER			
NO E.D.P.	5566-07B4	7 YES	TIN OVER COPPER			
NO E.D.P.	5566-08B4	8 YES	TIN OVER COPPER			
NO E.D.P.	5566-09B4	9 YES	TIN OVER COPPER			
NO E.D.P.	5566-10B4	10 YES	TIN OVER COPPER			
NO E.D.P.	5566-11B4	11 YES	TIN OVER COPPER			
NO E.D.P.	5566-12B4	12 YES	TIN OVER COPPER			
NO E.D.P.	5566-04A4	4 NO	TIN OVER COPPER			
NO E.D.P.	5566-05A4	5 NO	TIN OVER COPPER			
NO E.D.P.	5566-06A4	6 NO	TIN OVER COPPER			
NO E.D.P.	5566-07A4	7 NO	TIN OVER COPPER			
NO E.D.P.	5566-08A4	8 NO	TIN OVER COPPER			
NO E.D.P.	5566-09A4	9 NO	TIN OVER COPPER			
NO E.D.P.	5566-10A4	10 NO	TIN OVER COPPER			
NO E.D.P.	5566-11A4	11 NO	TIN OVER COPPER			
NO E.D.P.	5566-12A4	12 NO	TIN OVER COPPER			
NO E.D.P.	5566-04B4GS	4 YES	30 MI. SELECT GOLD			
NO E.D.P.	5566-05B4GS	5 YES	30 MI. SELECT GOLD			
NO E.D.P.	5566-06B4GS	6 YES	30 MI. SELECT GOLD			
NO E.D.P.	5566-07B4GS	7 YES	30 MI. SELECT GOLD			
NO E.D.P.	5566-08B4GS	8 YES	30 MI. SELECT GOLD			
NO E.D.P.	5566-09B4GS	9 YES	30 MI. SELECT GOLD			
NO E.D.P.	5566-10B4GS	10 YES	30 MI. SELECT GOLD			
NO E.D.P.	5566-11B4GS	11 YES	30 MI. SELECT GOLD			
NO E.D.P.	5566-12B4GS	12 YES	30 MI. SELECT GOLD			
NO E.D.P.	5566-04A4GS	4 NO	30 MI. SELECT GOLD			
NO E.D.P.	5566-05A4GS	5 NO	30 MI. SELECT GOLD			
NO E.D.P.	5566-06A4GS	6 NO	30 MI. SELECT GOLD			
NO E.D.P.	5566-07A4GS	7 NO	30 MI. SELECT GOLD			
NO E.D.P.	5566-08A4GS	8 NO	30 MI. SELECT GOLD			
NO E.D.P.	5566-09A4GS	9 NO	30 MI. SELECT GOLD			
NO E.D.P.	5566-10A4GS	10 NO	30 MI. SELECT GOLD			
NO E.D.P.	5566-11A4GS	11 NO	30 MI. SELECT GOLD			
NO E.D.P.	5566-12A4GS	12 NO	30 MI. SELECT GOLD			

6	5	4	3	2	1
PASSIVE LOCK WITH MTC, PEGS, 94V-0 HOUSING MATERIAL					
PART NO	ENG NO	CKT DRAIN SIZE/HOLE	PLATING OPTION		
NO E.D.P.	5566-04B4-210	4 YES	TIN OVER COPPER		
NO E.D.P.	5566-05B4-210	5 YES	TIN OVER COPPER		
NO E.D.P.	5566-06B4-210	6 YES	TIN OVER COPPER		
NO E.D.P.	5566-07B4-210	7 YES	TIN OVER COPPER		
NO E.D.P.	5566-08B4-210	8 YES	TIN OVER COPPER		
NO E.D.P.	5566-09B4-210	9 YES	TIN OVER COPPER		
NO E.D.P.	5566-10B4-210	10 YES	TIN OVER COPPER		
NO E.D.P.	5566-11B4-210	11 YES	TIN OVER COPPER		
NO E.D.P.	5566-12B4-210	12 YES	TIN OVER COPPER		
NO E.D.P.	5566-04A4-210	4 NO	TIN OVER COPPER		
NO E.D.P.	5566-05A4-210	5 NO	TIN OVER COPPER		
NO E.D.P.	5566-06A4-210	6 NO	TIN OVER COPPER		
NO E.D.P.	5566-07A4-210	7 NO	TIN OVER COPPER		
NO E.D.P.	5566-08A4-210	8 NO	TIN OVER COPPER		
NO E.D.P.	5566-09A4-210	9 NO	TIN OVER COPPER		
NO E.D.P.	5566-10A4-210	10 NO	TIN OVER COPPER		
NO E.D.P.	5566-11A4-210	11 NO	TIN OVER COPPER		
NO E.D.P.	5566-12A4-210	12 NO	TIN OVER COPPER		
NO E.D.P.	5566-04B4GS-210	4 YES	30 MI. SELECT GOLD		
NO E.D.P.	5566-05B4GS-210	5 YES	30 MI. SELECT GOLD		
NO E.D.P.	5566-06B4GS-210	6 YES	30 MI. SELECT GOLD		
NO E.D.P.	5566-07B4GS-210	7 YES	30 MI. SELECT GOLD		
NO E.D.P.	5566-08B4GS-210	8 YES	30 MI. SELECT GOLD		
NO E.D.P.	5566-09B4GS-210	9 YES	30 MI. SELECT GOLD		
NO E.D.P.	5566-10B4GS-210	10 YES	30 MI. SELECT GOLD		
NO E.D.P.	5566-11B4GS-210	11 YES	30 MI. SELECT GOLD		
NO E.D.P.	5566-12B4GS-210	12 YES	30 MI. SELECT GOLD		
NO E.D.P.	5566-04A4GS-210	4 NO	30 MI. SELECT GOLD		
NO E.D.P.	5566-05A4GS-210	5 NO	30 MI. SELECT GOLD		
NO E.D.P.	5566-06A4GS-210	6 NO	30 MI. SELECT GOLD		
NO E.D.P.	5566-07A4GS-210	7 NO	30 MI. SELECT GOLD		
NO E.D.P.	5566-08A4GS-210	8 NO	30 MI. SELECT GOLD		
NO E.D.P.	5566-09A4GS-210	9 NO	30 MI. SELECT GOLD		
NO E.D.P.	5566-10A4GS-210	10 NO	30 MI. SELECT GOLD		
NO E.D.P.	5566-11A4GS-210	11 NO	30 MI. SELECT GOLD		
NO E.D.P.	5566-12A4GS-210	12 NO	30 MI. SELECT GOLD		

13	12	11	10	9	8	7
POSITIVE LOCK WITH MTC, PEGS, 94V-2 HOUSING MATERIAL						
PART NO	ENG NO	CKT DRAIN SIZE/HOLE	PLATING OPTION			
39-30-2045	5566-04B3	4 YES	TIN OVER COPPER			
39-30-2055	5566-05B3	5 YES	TIN OVER COPPER			
39-30-2065	5566-06B3	6 YES	TIN OVER COPPER			
39-30-2075	5566-07B3	7 YES	TIN OVER COPPER			
39-30-2085	5566-08B3	8 YES	TIN OVER COPPER			
39-30-2095	5566-09B3	9 YES	TIN OVER COPPER			
39-30-2105	5566-10B3	10 YES	TIN OVER COPPER			
39-30-2115	5566-11B3	11 YES	TIN OVER COPPER			
39-30-2125	5566-12B3	12 YES	TIN OVER COPPER			
39-30-1049	5566-04A3	4 NO	TIN OVER COPPER			
39-30-1059	5566-05A3	5 NO	TIN OVER COPPER			
39-30-1069	5566-06A3	6 NO	TIN OVER COPPER			
39-30-1079	5566-07A3	7 NO	TIN OVER COPPER			
39-30-1089	5566-08A3	8 NO	TIN OVER COPPER			
39-30-1099	5566-09A3	9 NO	TIN OVER COPPER			
39-30-1109	5566-10A3	10 NO	TIN OVER COPPER			
39-30-1119	5566-11A3	11 NO	TIN OVER COPPER			
39-30-1129	5566-12A3	12 NO	TIN OVER COPPER			
39-30-2047	5566-04B3GS	4 YES	30 MI. SELECT GOLD			
39-30-2057	5566-05B3GS	5 YES	30 MI. SELECT GOLD			
39-30-2067	5566-06B3GS	6 YES	30 MI. SELECT GOLD			
39-30-2077	5566-07B3GS	7 YES	30 MI. SELECT GOLD			
39-30-2087	5566-08B3GS	8 YES	30 MI. SELECT GOLD			
39-30-2097	5566-09B3GS	9 YES	30 MI. SELECT GOLD			
39-30-2107	5566-10B3GS	10 YES	30 MI. SELECT GOLD			
39-30-2117	5566-11B3GS	11 YES	30 MI. SELECT GOLD			
39-30-2127	5566-12B3GS	12 YES	30 MI. SELECT GOLD			
39-30-2041	5566-04A3GS	4 NO	30 MI. SELECT GOLD			
39-30-2051	5566-05A3GS	5 NO	30 MI. SELECT GOLD			
39-30-2061	5566-06A3GS	6 NO	30 MI. SELECT GOLD			
39-30-2071	5566-07A3GS	7 NO	30 MI. SELECT GOLD			
39-30-2081	5566-08A3GS	8 NO	30 MI. SELECT GOLD			
39-30-2091	5566-09A3GS	9 NO	30 MI. SELECT GOLD			
39-30-2101	5566-10A3GS	10 NO	30 MI. SELECT GOLD			
39-30-2111	5566-11A3GS	11 NO	30 MI. SELECT GOLD			
39-30-2121	5566-12A3GS	12 NO	30 MI. SELECT GOLD			

6	5	4	3	2	1
POSITIVE LOCK WITH MTC, PEGS, 94V-0 HOUSING MATERIAL					
PART NO	ENG NO	CKT DRAIN SIZE/HOLE	PLATING OPTION		
39-30-2046	5566-04B3-210	4 YES	TIN OVER COPPER		
39-30-2056	5566-05B3-210	5 YES	TIN OVER COPPER		
39-30-2066	5566-06B3-210	6 YES	TIN OVER COPPER		
39-30-2076	5566-07B3-210	7 YES	TIN OVER COPPER		
39-30-2086	5566-08B3-210	8 YES	TIN OVER COPPER		
39-30-2096	5566-09B3-210	9 YES	TIN OVER COPPER		
39-30-2106	5566-10B3-210	10 YES	TIN OVER COPPER		
39-30-2116	5566-11B3-210	11 YES	TIN OVER COPPER		
39-30-2126	5566-12B3-210	12 YES	TIN OVER COPPER		
39-30-2040	5566-04A3-210	4 NO	TIN OVER COPPER		
39-30-2050	5566-05A3-210	5 NO	TIN OVER COPPER		
39-30-2060	5566-06A3-210	6 NO	TIN OVER COPPER		
39-30-2070	5566-07A3-210	7 NO	TIN OVER COPPER		
39-30-2080	5566-08A3-210	8 NO	TIN OVER COPPER		
39-30-2090	5566-09A3-210	9 NO	TIN OVER COPPER		
39-30-2100	5566-10A3-210	10 NO	TIN OVER COPPER		
39-30-2110	5566-11A3-210	11 NO	TIN OVER COPPER		
39-30-2120	5566-12A3-210	12 NO	TIN OVER COPPER		
39-30-2048	5566-04B3GS-210	4 YES	30 MI. SELECT GOLD		
39-30-2058	5566-05B3GS-210	5 YES	30 MI. SELECT GOLD		
39-30-2068	5566-06B3GS-210	6 YES	30 MI. SELECT GOLD		
39-30-2078	5566-07B3GS-210	7 YES	30 MI. SELECT GOLD		
39-30-2088	5566-08B3GS-210	8 YES	30 MI. SELECT GOLD		
39-30-2098	5566-09B3GS-210	9 YES	30 MI. SELECT GOLD		
39-30-2108	5566-10B3GS-210	10 YES	30 MI. SELECT GOLD		
39-30-2118	5566-11B3GS-210	11 YES	30 MI. SELECT GOLD		
39-30-2128	5566-12B3GS-210	12 YES	30 MI. SELECT GOLD		
39-30-2042	5566-04A3GS-210	4 NO	30 MI. SELECT GOLD		
39-30-2052	5566-05A3GS-210	5 NO	30 MI. SELECT GOLD		
39-30-2062	5566-06A3GS-210	6 NO	30 MI. SELECT GOLD		
39-30-2072	5566-07A3GS-210	7 NO	30 MI. SELECT GOLD		
39-30-2082	5566-08A3GS-210	8 NO	30 MI. SELECT GOLD		
39-30-2092	5566-09A3GS-210	9 NO	30 MI. SELECT GOLD		
39-30-2102	5566-10A3GS-210	10 NO	30 MI. SELECT GOLD		
39-30-2112	5566-11A3GS-210	11 NO	30 MI. SELECT GOLD		
39-30-2122	5566-12A3GS-210	12 NO	30 MI. SELECT GOLD		

SEE SHEET 1
 FC NO: UCP2006-1990 2006/02/28
 DRAWN:ADRAINOL 2006/02/28
 CHKD:JPOLGAR 2006/02/28
 APPR:ICOMERCI 2006/02/28

QUALITY SYMBOLS

DESCRIPTION
 VERTICAL HEADER ASSY W/ PEG AND DRAIN OPTIONS MINI-FIT JR SINGLE ROW

GENERAL TOLERANCES (UNLESS SPECIFIED)
 mm INCH
 4 PLACES ± --- ± ---
 3 PLACES ± --- ± ---
 2 PLACES ± --- ± ---
 1 PLACE ± --- ± ---
 ANGULAR ± --- °

DIMENSION STYLE
 IN/MM
 DRAWN BY DATE
 GEP 1989/07/13
 CHECKED BY DATE
 RJF 1989/07/13
 APPROVED BY DATE
 RAS 1989/07/13

SCALE

 DESIGN UNITS
 METRIC

THIRD ANGLE PROJECTION

MOLEX MOLEX INCORPORATED
 MATERIAL NO. SDA-5566-NL*
 DOCUMENT NO. SHEET NO. 2 OF 4

DRAFT WHERE APPLICABLE MUST REMAIN WITHIN DIMENSIONS
 THIS DRAWING CONTAINS INFORMATION THAT IS PROPRIETARY TO MOLEX INCORPORATED AND SHOULD NOT BE USED WITHOUT WRITTEN PERMISSION

13	PASSIVE LOCK WITH MTG. PEGS, 94V-2 BLACK HOUSING		
12	POSITIVE LOCK WITH MTG. PEGS, 94V-2 BLACK HOUSING		
11	POSITIVE LOCK WITH MTG. PEGS, 94V-2 BLACK HOUSING		
10	POSITIVE LOCK WITH MTG. PEGS, 94V-2 BLACK HOUSING		
9	POSITIVE LOCK WITH MTG. PEGS, 94V-2 BLACK HOUSING		
8	POSITIVE LOCK WITH MTG. PEGS, 94V-2 BLACK HOUSING		
7	POSITIVE LOCK WITH MTG. PEGS, 94V-2 BLACK HOUSING		
6	POSITIVE LOCK WITH MTG. PEGS, 94V-2 BLACK HOUSING		
5	POSITIVE LOCK WITH MTG. PEGS, 94V-2 BLACK HOUSING		
4	POSITIVE LOCK WITH MTG. PEGS, 94V-2 BLACK HOUSING		
3	POSITIVE LOCK WITH MTG. PEGS, 94V-2 BLACK HOUSING		
2	POSITIVE LOCK WITH MTG. PEGS, 94V-2 BLACK HOUSING		
1	POSITIVE LOCK WITH MTG. PEGS, 94V-2 BLACK HOUSING		

PART NO	ENG NO	CKT DRAIN SIZE HOLE	PLATING OPTION
50-29-1528	5566-04A3-BL	04 NO	TIN OVER COPPER
50-29-1529	5566-05A3-BL	05 NO	TIN OVER COPPER
50-29-1530	5566-06A3-BL	06 NO	TIN OVER COPPER
50-29-1531	5566-07A3-BL	07 NO	TIN OVER COPPER
50-29-1532	5566-08A3-BL	08 NO	TIN OVER COPPER
50-29-1533	5566-09A3-BL	09 NO	TIN OVER COPPER
50-29-1534	5566-10A3-BL	10 NO	TIN OVER COPPER
50-29-1535	5566-11A3-BL	11 NO	TIN OVER COPPER
50-29-1536	5566-12A3-BL	12 NO	TIN OVER COPPER
26-01-3162	5566-04A3S-BL	04 NO	TIN OVER NICKEL
26-01-3163	5566-05A3S-BL	05 NO	TIN OVER NICKEL
		06	
		07	
		08	
		09	
		10	
		11	
		12	
		04	
		05	
		06	
		07	
		08	
		09	
		10	
		11	
		12	
		04	
		05	
		06	
		07	
		08	
		09	
		10	
		11	
		12	
		04	
		05	
		06	
		07	
		08	
		09	
		10	
		11	
		12	
		04	
		05	
		06	
		07	
		08	
		09	
		10	
		11	
		12	

SEE SHEET 1	EC NO: UCP2010-1922	2009/02/12
DRWN:TBENES	CHKD:JBELL	2010/02/12
APPR:FSMITH		2010/02/15
REV	DESCRIPTION	
M		

QUALITY SYMBOLS	$\nabla = 0$	$\nabla = 0$
-----------------	--------------	--------------

GENERAL TOLERANCES (UNLESS SPECIFIED)	mm	INCH
4 PLACES	± ---	± ---
3 PLACES	± ---	± ---
2 PLACES	± ---	± ---
1 PLACE	± ---	± ---
ANGULAR	± ---°	
DRAFT WHERE APPLICABLE MUST REMAIN WITHIN DIMENSIONS		

DIMENSION STYLE		SCALE	DESIGN UNITS	THIRD ANGLE PROJECTION
IN/MM		1:1	METRIC	
DRAWN BY	DATE	TITLE		
GEP	1989/07/13	VERTICAL HEADER ASSY W/ PEG AND DRAIN OPTIONS MINI-FIT JR SINGLE ROW		
CHECKED BY	DATE	MOLEX INCORPORATED		
RJF	1989/07/13			
APPROVED BY	DATE	DOCUMENT NO.		
RAS	1989/07/13	SDA-5566-NL*		
MATERIAL NO.	SEE CHART	SHEET NO.		
		3 OF 4		
THIS DRAWING CONTAINS INFORMATION THAT IS PROPRIETARY TO MOLEX INCORPORATED AND SHOULD NOT BE USED WITHOUT WRITTEN PERMISSION				

PART NO	ENG NO	CKT DRAIN SIZE HOLE	PLATING OPTION
39-30-5049	5566-04B3S	04 YES	TIN OVER NICKEL
NO EDP	5566-05B3S	05 YES	TIN OVER NICKEL
NO EDP	5566-06B3S	06 YES	TIN OVER NICKEL
NO EDP	5566-07B3S	07 YES	TIN OVER NICKEL
NO EDP	5566-08B3S	08 YES	TIN OVER NICKEL
NO EDP	5566-09B3S	09 YES	TIN OVER NICKEL
NO EDP	5566-10B3S	10 YES	TIN OVER NICKEL
NO EDP	5566-11B3S	11 YES	TIN OVER NICKEL
NO EDP	5566-12B3S	12 YES	TIN OVER NICKEL
50-36-2453	5566-04A3S	04 NO	TIN OVER NICKEL
50-36-2454	5566-05A3S	05 NO	TIN OVER NICKEL
		06	
		07	
		08	
		09	
		10	
		11	
		12	
		04	
		05	
		06	
		07	
		08	
		09	
		10	
		11	
		12	
		04	
		05	
		06	
		07	
		08	
		09	
		10	
		11	
		12	
		04	
		05	
		06	
		07	
		08	
		09	
		10	
		11	
		12	
		04	
		05	
		06	
		07	
		08	
		09	
		10	
		11	
		12	
		04	
		05	
		06	
		07	
		08	
		09	
		10	
		11	
		12	
		04	
		05	
		06	
		07	
		08	
		09	
		10	
		11	
		12	

PART NO	ENG NO	CKT DRAIN SIZE HOLE	PLATING OPTION
		04	
		05	
		06	
		07	
		08	
		09	
		10	
		11	
		12	
		04	
		05	
		06	
		07	
		08	
		09	
		10	
		11	
		12	
		04	
		05	
		06	
		07	
		08	
		09	
		10	
		11	
		12	
		04	
		05	
		06	
		07	
		08	
		09	
		10	
		11	
		12	
		04	
		05	
		06	
		07	
		08	
		09	
		10	
		11	
		12	
		04	
		05	
		06	
		07	
		08	
		09	
		10	
		11	
		12	
		04	
		05	
		06	
		07	
		08	
		09	
		10	
		11	
		12	
		04	
		05	
		06	
		07	
		08	
		09	
		10	
		11	
		12	