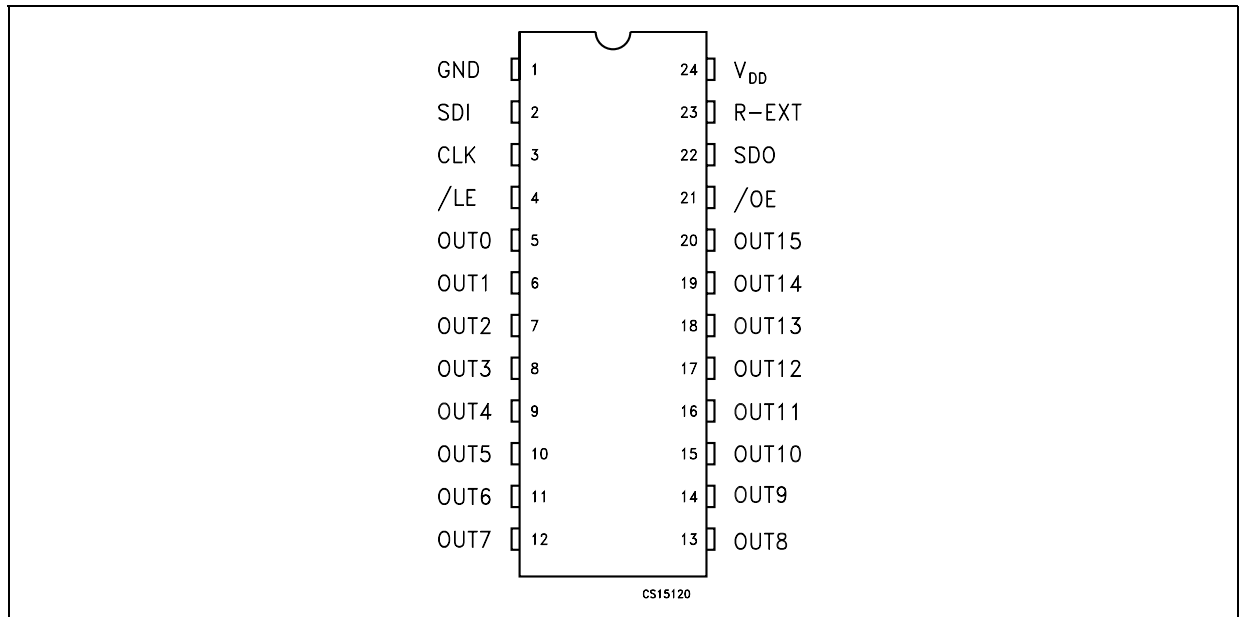


Table 2: Typical Current Accuracy

Output Voltage	Output Current	Between Bits	Between ICs
$\geq 0.1V$	$3 \text{ mA}/V_{CC} = 5V$	$\pm 3\%$	$\pm 6\%$
$\geq 0.15V$	$5 \text{ mA}/V_{CC} = 5V$	$\pm 2\%$	$\pm 6\%$
$\geq 0.25V$	$10 \text{ mA}/V_{CC} = 5V$	$\pm 2\%$	$\pm 6\%$
$\geq 0.5V$	$20 \text{ mA}/V_{CC} = 5V$	$\pm 1\%$	$\pm 6\%$
$\geq 1.2V$	$40 \text{ mA}/V_{CC} = 5V$	$\pm 1\%$	$\pm 6\%$
$\geq 1.4V$	$50 \text{ mA}/V_{CC} = 5V$	$\pm 1\%$	$\pm 6\%$

Figure 1: Pin Connection (Note 1)



Note 1: The exposed Pad is electrically not connected.

Table 3: Pin Description

PIN N°	Symbol	Name and Function
1	GND	Ground Terminal
2	SDI	Serial data input terminal
3	CLK	Clock input terminal
4	/LE	Latch input terminal
5-20	OUT 0-15	Output terminal
21	/OE	Input terminal of output enable (active low)
22	SDO	Serial data out terminal
23	R-EXT	Input terminal of an external resistor for constant current programing
24	V _{DD}	Supply voltage terminal

Table 4: Absolute Maximum Ratings

Symbol	Parameter	Value	Unit
V_{DD}	Supply Voltage	0 to 7	V
V_O	Output Voltage	-0.5 to 16	V
I_O	Output Current	50	mA
V_I	Input Voltage	-0.4 to $V_{DD}+0.4$	V
I_{GND}	GND Terminal Current	800	mA
f_{CLK}	Clock Frequency	25	MHz
T_{OPR}	Operating Temperature Range	-40 to +125	°C
T_{STG}	Storage Temperature Range	-65 to +150	°C

Absolute Maximum Ratings are those values beyond which damage to the device may occur. Under these conditions, functional operation is not implied.

Table 5: Thermal Data

Symbol	Parameter	DIP-24	SO-24	TSSOP24	TSSOP24 (*) (exposed pad)	Unit
$R_{thj-amb}$	Thermal Resistance Junction-ambient	60	75	85	37.5	°C/W

(*) The exposed pad should be soldered directly to the PCB to realize the thermal benefits.

Table 6: Recommended Operating Conditions

Symbol	Parameter	Test Conditions	Min.	Typ.	Max.	Unit
V_{DD}	Supply Voltage		3.0		5.5	V
V_O	Output Voltage				16.0	V
I_O	Output Current	OUTn	3		50	mA
I_{OH}	Output Current	SERIAL-OUT			+1	mA
I_{OL}	Output Current	SERIAL-OUT			-1	mA
V_{IH}	Input Voltage		$0.7V_{DD}$		$V_{DD}+0.3$	V
V_{IL}	Input Voltage		-0.3		$0.3V_{DD}$	V
t_{wLAT}	/LE Pulse Width	$V_{DD} = 3.0$ to $3.6V$	20			ns
t_{wCLK}	CLK Pulse Width		20			ns
t_{wEN}	/OE Pulse Width		400			ns
$t_{SETUP(D)}$	Setup Time for DATA		20			ns
$t_{HOLD(D)}$	Hold Time for DATA		15			ns
$t_{REM(L)}$	Removal Time for LATCH		15			ns
f_{CLK}	Clock Frequency	Cascade Operation			25	MHz

Table 7: Electrical Characteristics ($V_{DD}=3.3V$ to $5V$, $T = 25^{\circ}C$, unless otherwise specified.)

Symbol	Parameter	Test Conditions	Min.	Typ.	Max.	Unit
V_{IH}	Input Voltage High Level		$0.7V_{DD}$		V_{DD}	V
V_{IL}	Input Voltage Low Level		GND		$0.3V_{DD}$	V
I_{OH}	Output Leakage Current	$V_{OH} = 16 V$			10	μA
V_{OL}	Output Voltage (Serial-OUT)	$I_{OL} = 1mA$			0.4	V
V_{OH}	Output Voltage (Serial-OUT)	$I_{OH} = -1mA$	$V_{DD}-0.4V$			V
I_{OL1A}	Output Current	$V_O = \geq 0.2V$, $R_{EXT}=6.2K\Omega$, $V_{DD}=3.3V$	2.85	3	3.15	mA
I_{OL2A}		$V_O = \geq 0.5V$, $R_{EXT}=1K\Omega$, $V_{DD} = 3.3V$	19.6	20	20.4	mA
ΔI_{OL1A}	Output Current Error between bit (All Output ON)	$V_O = \geq 0.2V$, $R_{EXT}=6.2K\Omega$, $V_{DD}=3.3V$		± 4	± 6	%
ΔI_{OL2A}		$V_O = \geq 0.5V$, $R_{EXT}=1K\Omega$, $V_{DD} = 3.3V$		± 2	± 3	%
I_{OL1B}	Output Current	$V_O = \geq 0.2V$, $R_{EXT}=6.2K\Omega$, $V_{DD}=5V$	2.9	3	3.1	mA
I_{OL2B}		$V_O = \geq 0.5V$, $R_{EXT}=1K\Omega$, $V_{DD} = 5V$	19.6	20	20.4	mA
ΔI_{OL1B}	Output Current Error between bit (All Output ON)	$V_O = \geq 0.2V$, $R_{EXT}=6.2K\Omega$, $V_{DD}=5V$		± 2	± 3.5	%
ΔI_{OL2B}		$V_O = \geq 0.5V$, $R_{EXT}=1K\Omega$, $V_{DD} = 5V$		± 1	± 2	%
$R_{SIN(up)}$	Pull-up Resistor		150	300	600	K Ω
$R_{SIN(down)}$	Pull-down Resistor		100	200	400	K Ω
$I_{DD(OFF1)}$	Supply Current (OFF)	$R_{EXT} = OPEN$ OUT 0 to 15 = OFF		0.3		mA
$I_{DD(OFF2)}$		$R_{EXT} = 6.2K\Omega$ OUT 0 to 15 = OFF		1		
$I_{DD(OFF3)}$		$R_{EXT} = 1K\Omega$ OUT 0 to 15 = OFF		3		
$I_{DD(ON1)}$	Supply Current (ON)	$R_{EXT} = 6.2K\Omega$ OUT 0 to 15 = ON		1		
$I_{DD(ON2)}$		$R_{EXT} = 1K\Omega$ OUT 0 to 15 = ON		3		

Table 8: Switching Characteristics ($V_{DD}=3V$, $T = 25^{\circ}C$, unless otherwise specified.)

Symbol	Parameter	Test Conditions	Min.	Typ.	Max.	Unit
t_{PLH1}	Propagation Delay Time, CLK-OUTn, /LE = H, /OE = L	$V_{DD} = 3 V$ $V_{IL} = GND$ $I_O = 40mA$		250	280	ns
t_{PLH2}	Propagation Delay Time, /LE-OUTn, /OE = L					
t_{PLH3}	Propagation Delay Time, /OE-OUTn, /LE = H	$R_{EXT} = 470 \Omega$	$R_L = 65 \Omega$	200	250	ns
t_{PLH}	Propagation Delay Time, CLK-SDO			25	50	ns
t_{PHL1}	Propagation Delay Time, CLK-OUTn, /LE = H, /OE = L			25	50	ns
t_{PHL2}	Propagation Delay Time, /LE-OUTn, /OE = L			25	50	ns
t_{PHL3}	Propagation Delay Time, /OE-OUTn, /LE = H			50	70	ns
t_{PHL}	Propagation Delay Time, CLK-SDO			25	50	ns
t_{ON}	Output Rise Time	10 ~ 90% of voltage waveform		260	400	ns
t_{OFF}	Output Fall Time	90 ~ 10% of voltage waveform		50	80	ns

EQUIVALENT CIRCUIT OF INPUTS AND OUTPUTS

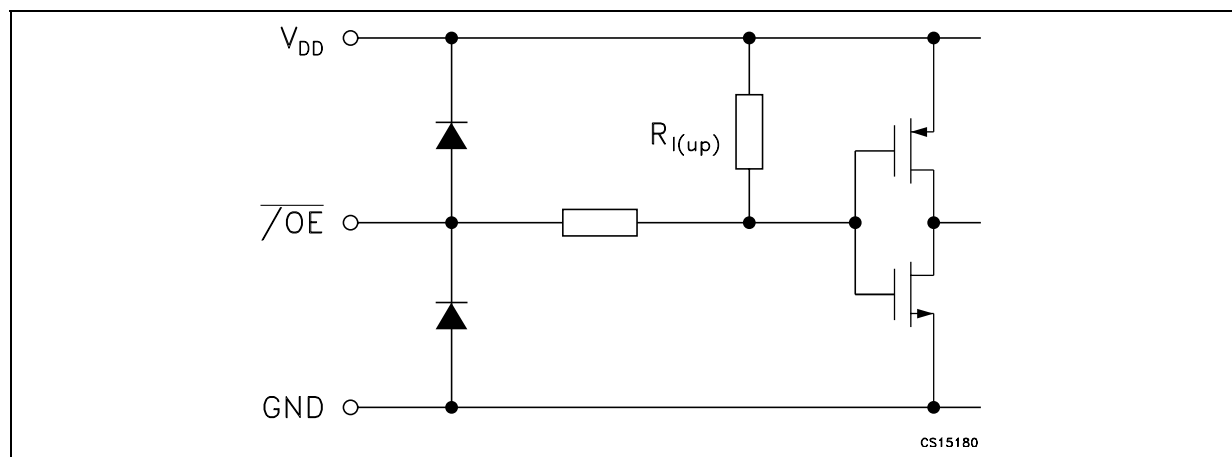
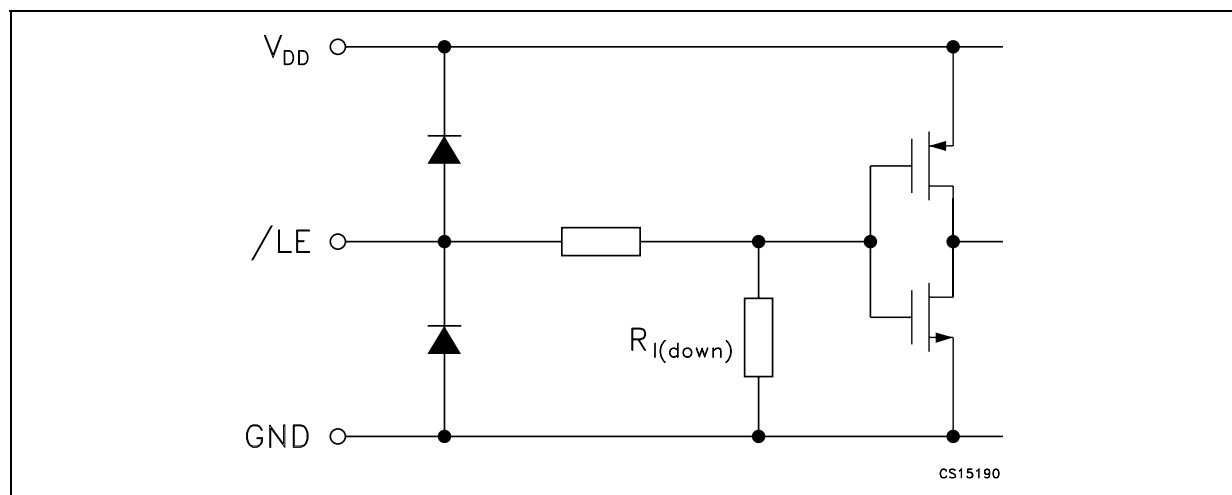
Figure 2: \overline{OE} TerminalFigure 3: \overline{LE} Terminal

Figure 4: CLK, SDI Terminal

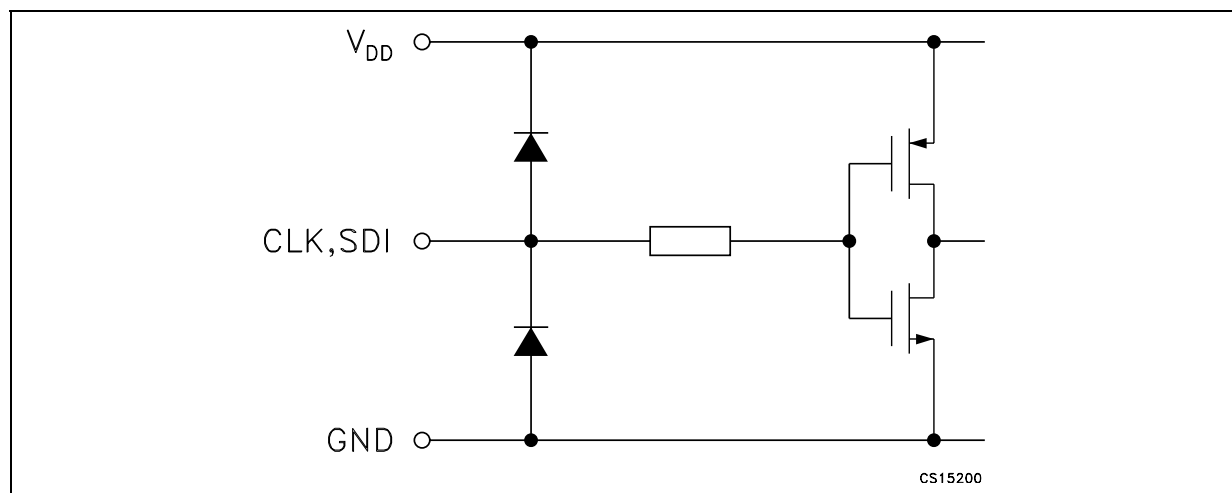


Figure 5: SDO Terminal

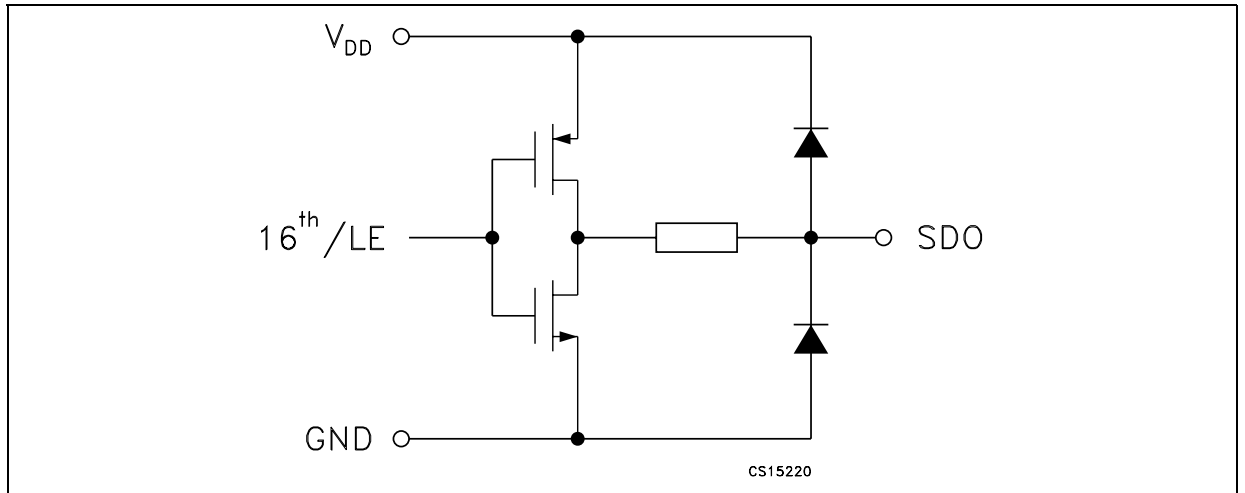


Figure 6: Block Diagram

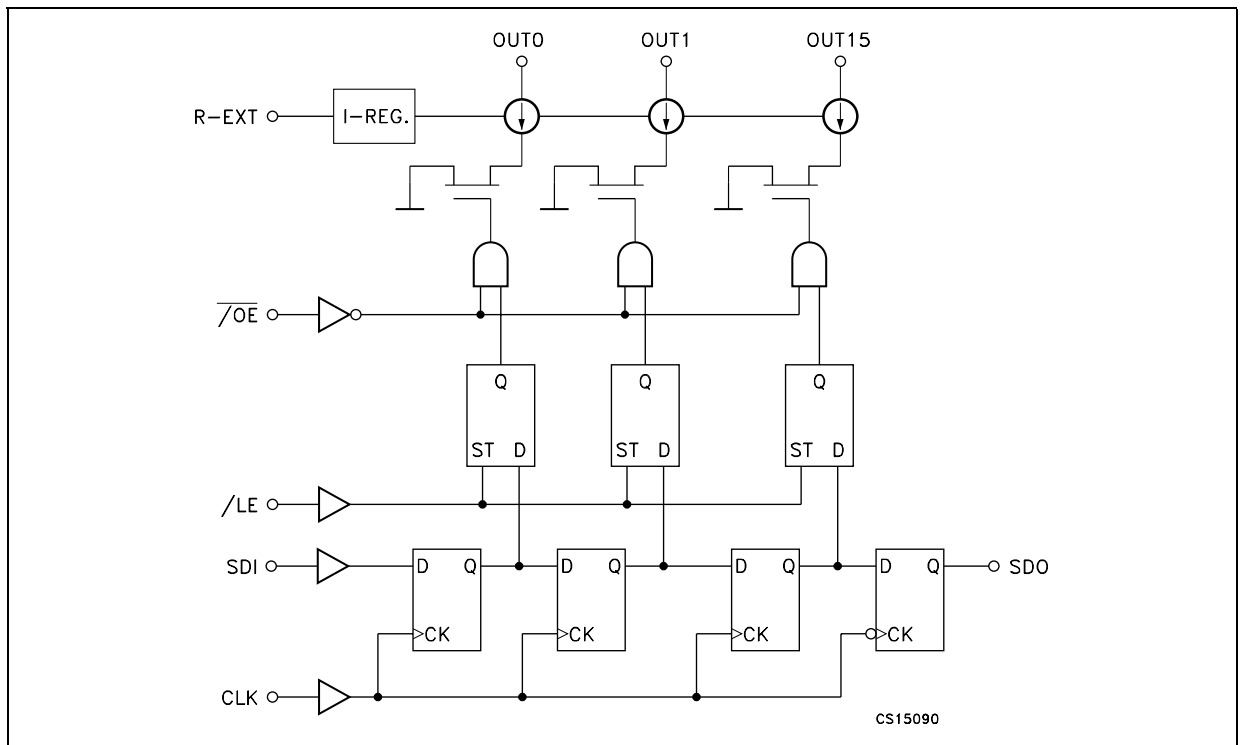
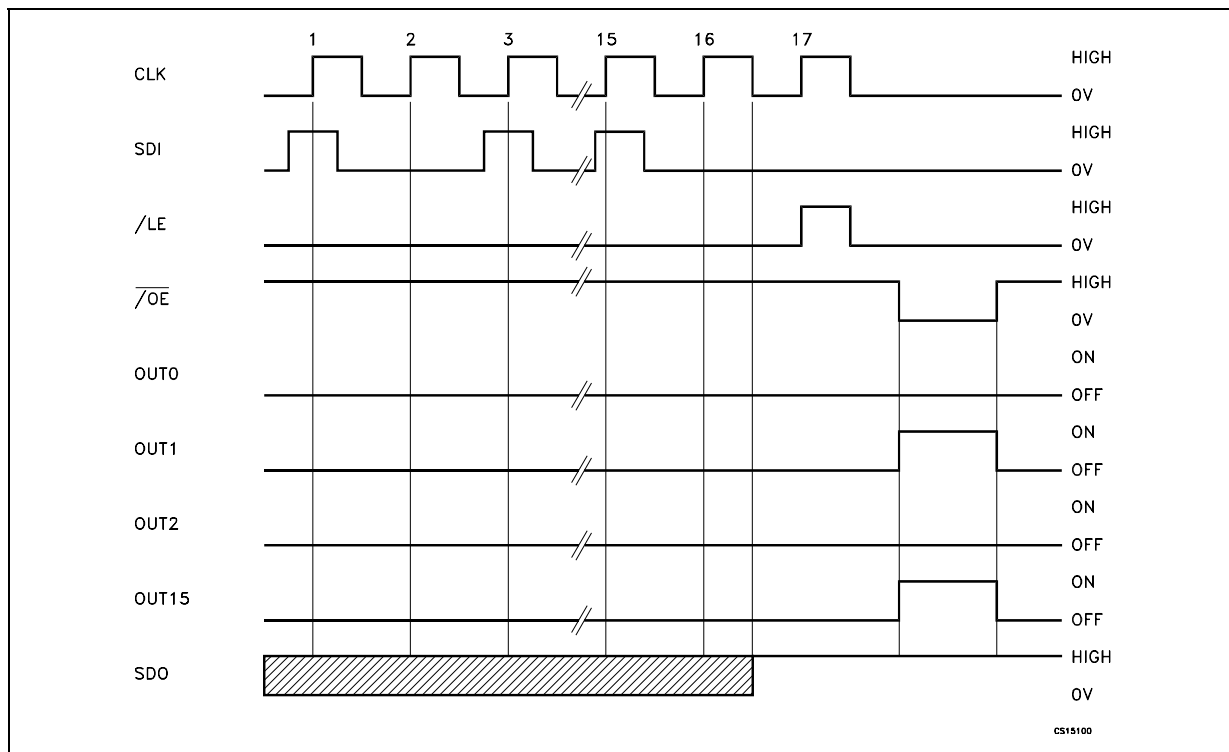


Table 9: Truth Table

CLOCK	/LE	/OE	SERIAL-IN	OUT0 OUT7 OUT15	SDO
	H	L	Dn	Dn Dn - 7 Dn -15	Dn - 15
	L	L	Dn + 1	No Change	Dn - 14
	H	L	Dn + 2	Dn - 2 Dn - 5 Dn -13	Dn - 13
	X	L	Dn + 3	Dn - 2 Dn - 5 Dn -13	Dn - 13
	X	L	Dn + 3	OFF	Dn - 13

Note 1: OUT0 to OUT15 = ON when Dn = H; OUT0 to OUT15 = OFF when Dn = L.

Figure 7: Timing Diagram



Note: The latches circuit holds data when the LE terminal is Low.
 When LE terminal is at High level, latch circuit doesn't hold the data it passes from the input to the output.
 When OE terminal is at Low level, output terminals OUT0 to OUT15 respond to the data, either ON or OFF.
 When OE terminal is at High level, it switches off all the data on the output terminal.

Figure 8: Clock, Serial-in, Serial-out

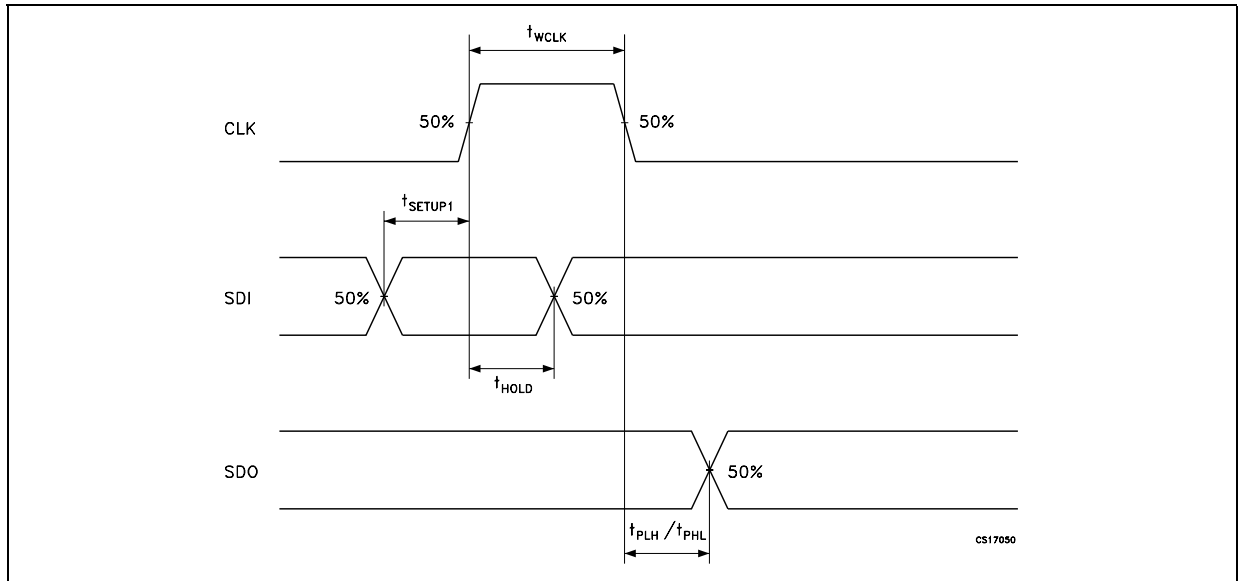


Figure 9: Clock, Serial-in, Latch, Enable, Outputs

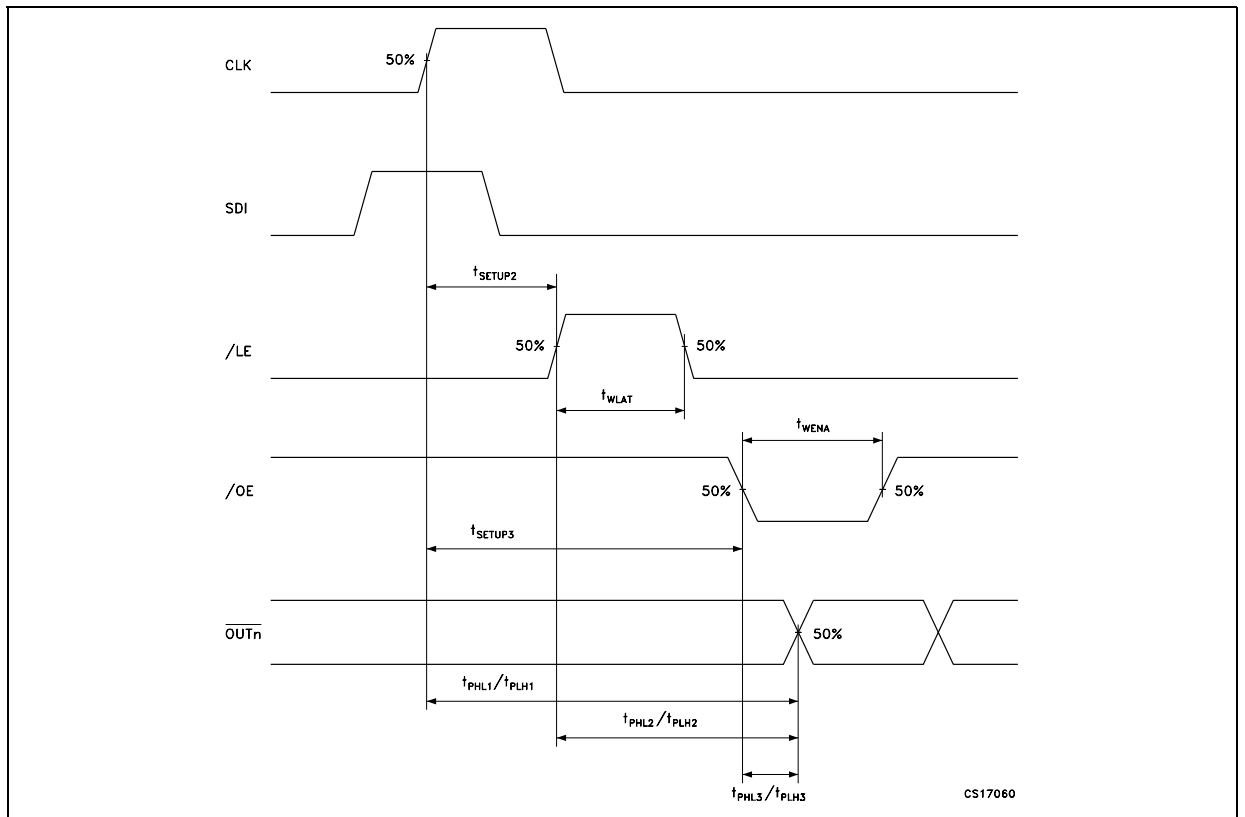
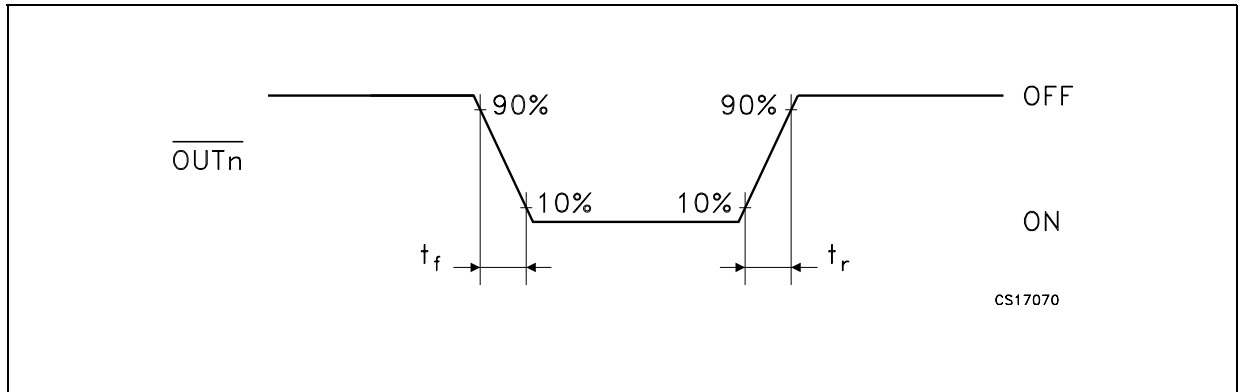


Figure 10: Outputs



TEST CIRCUIT

Figure 11: DC Characteristic

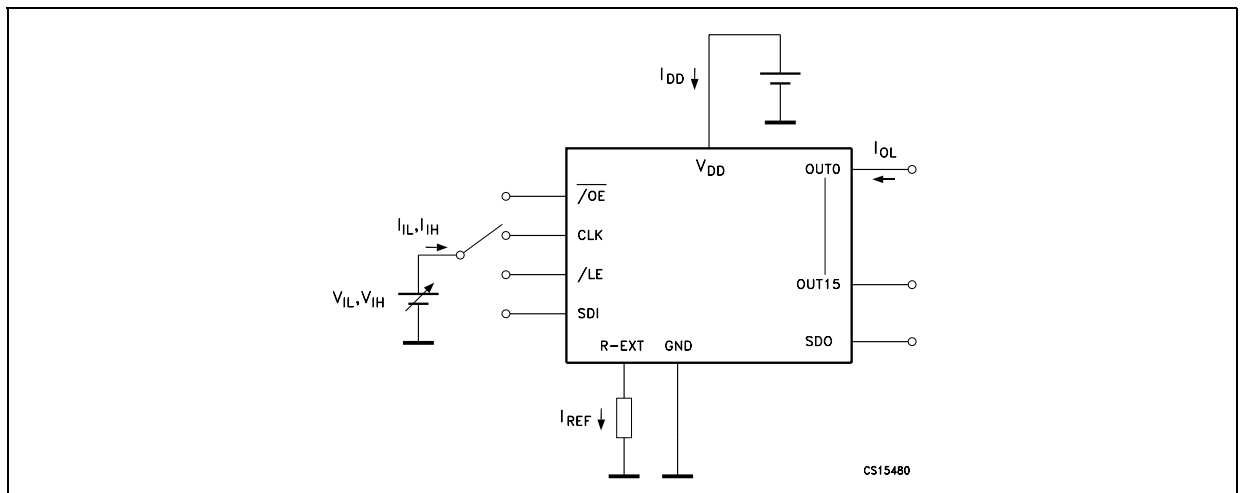


Figure 12: AC Characteristic

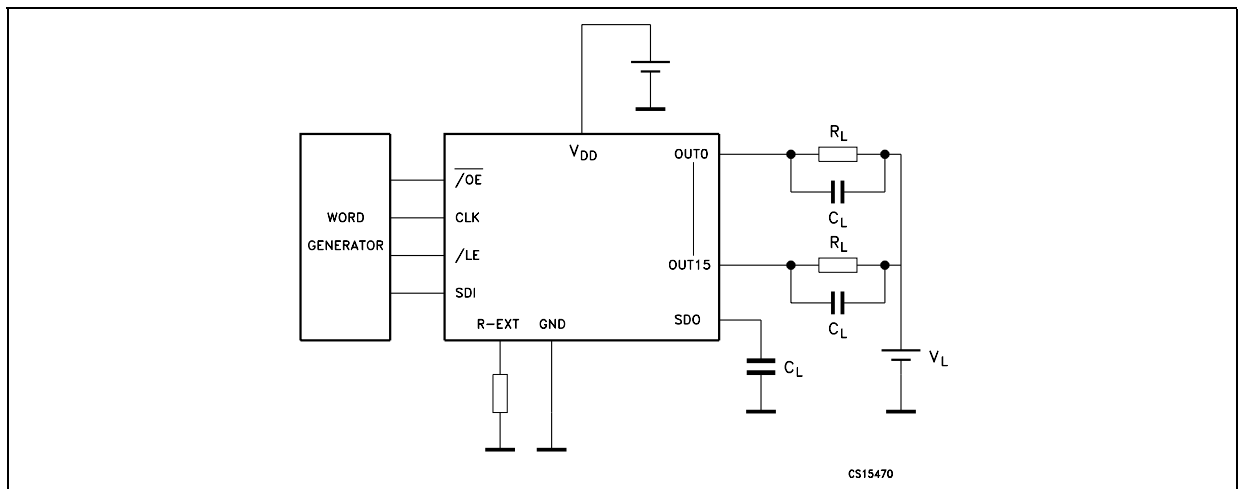


Figure 13: Output Current- R_{EXT} Resistor

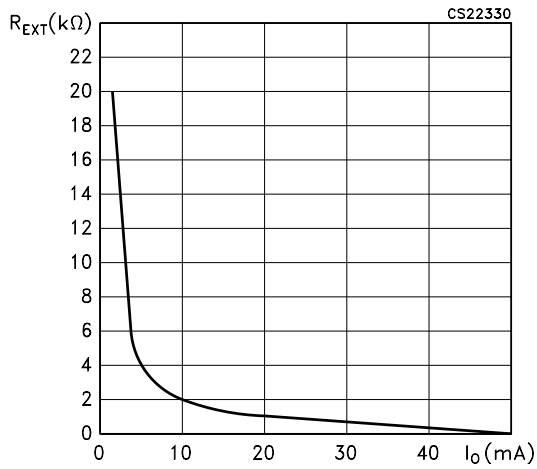


Figure 15: Output Current vs Dropout Voltage

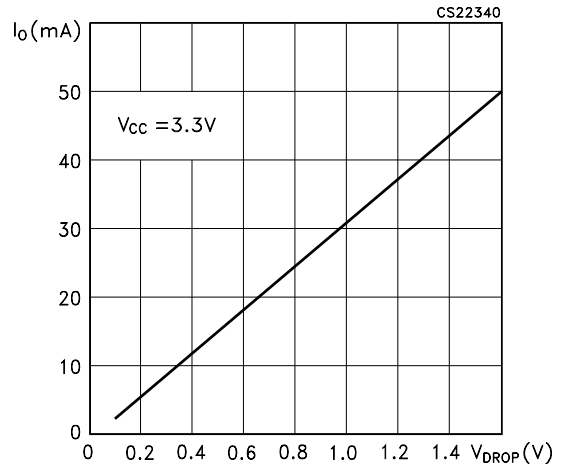


Figure 14: Power Dissipation vs Temperature Package

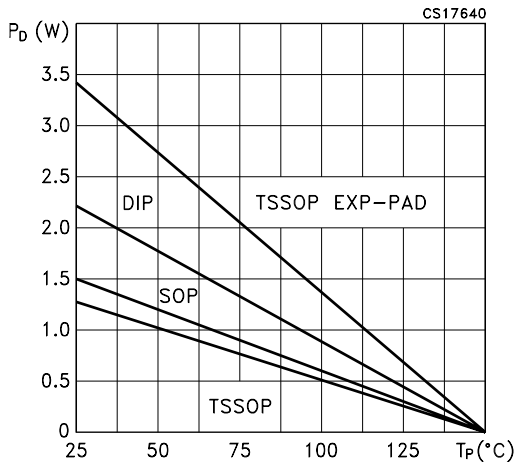
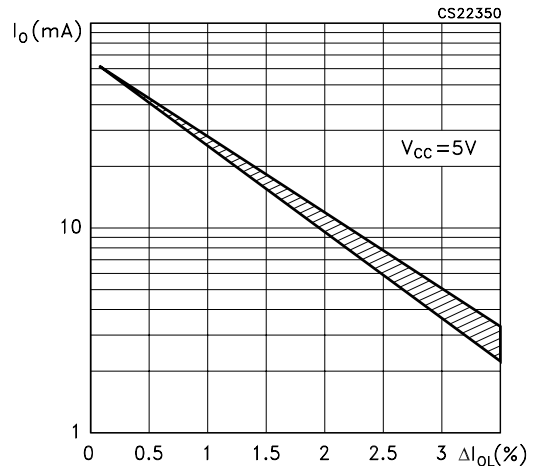
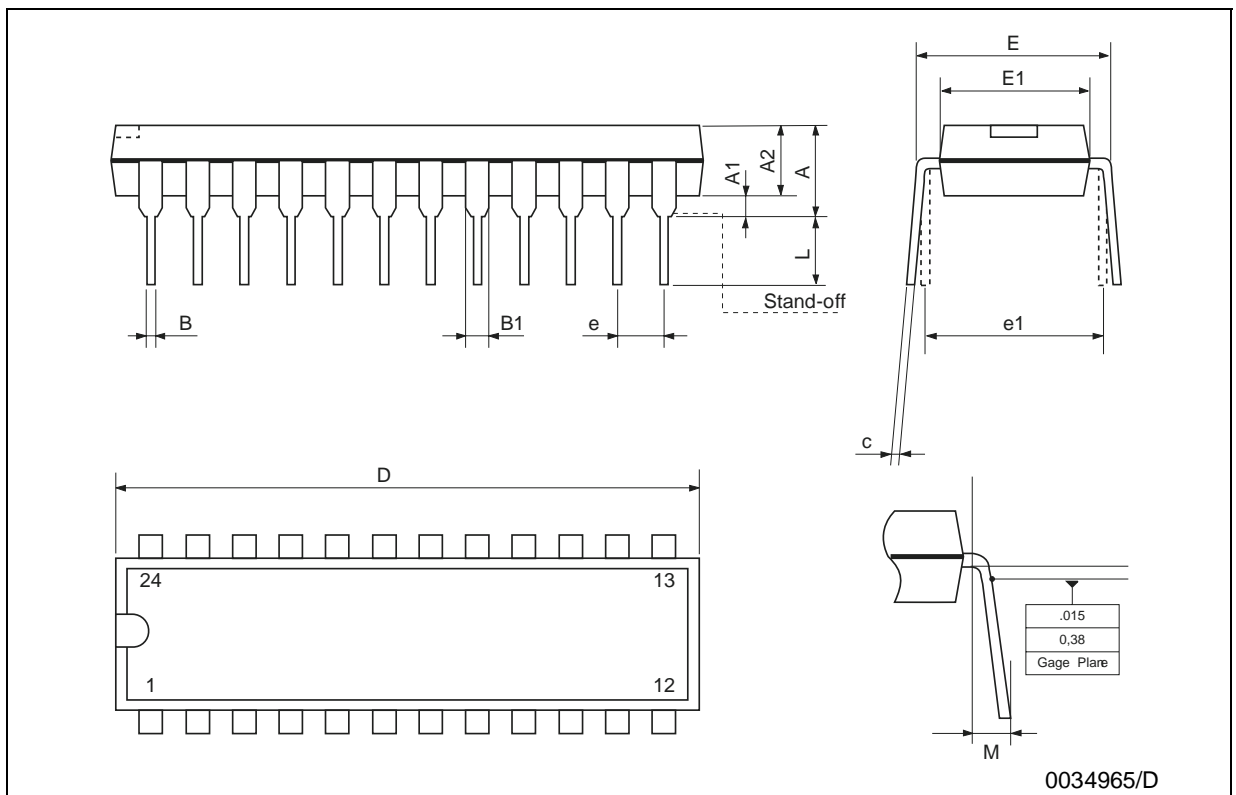


Figure 16: Output Current vs $\pm\Delta I_{OL}$ (%)



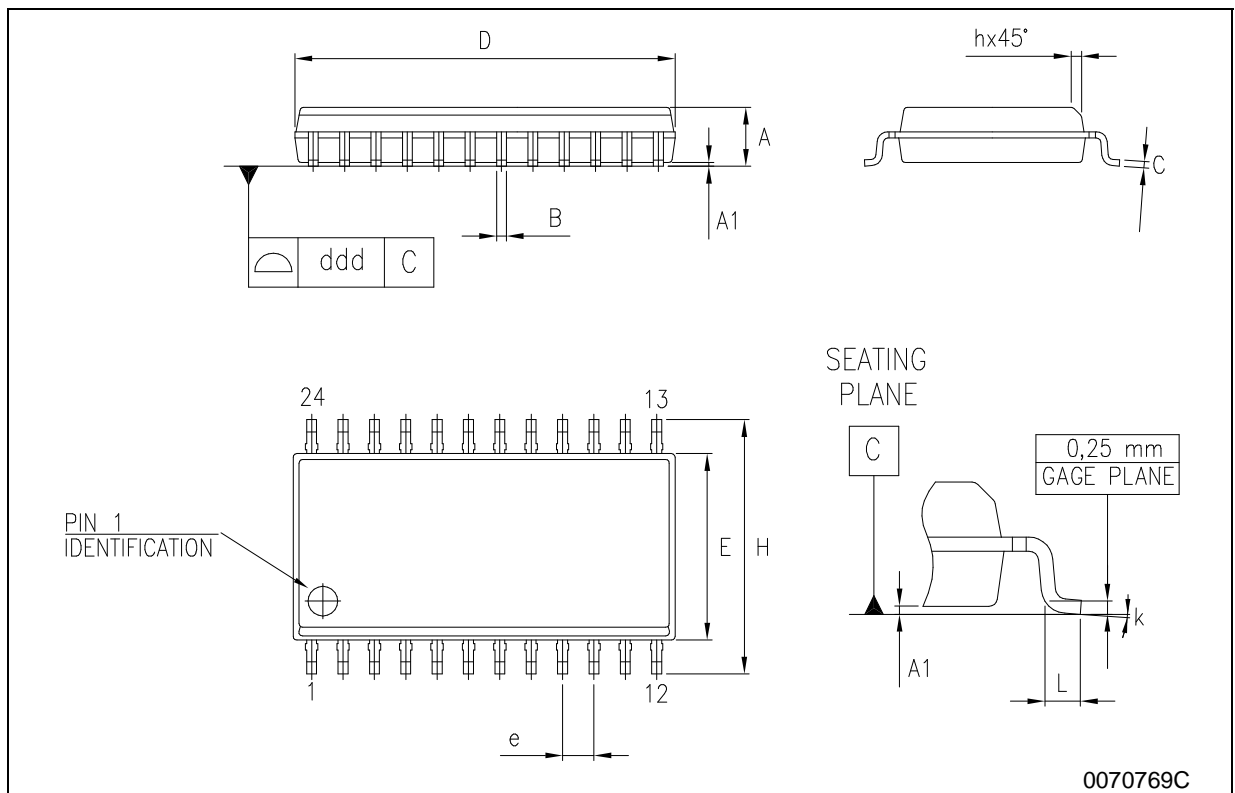
Plastic DIP-24 (0.25) MECHANICAL DATA

DIM.	mm.			inch		
	MIN.	TYP	MAX.	MIN.	TYP.	MAX.
A			4.32			0.170
A1	0.38			0.015		
A2		3.3			0.130	
B	0.41	0.46	0.51	0.016	0.018	0.020
B1	1.40	1.52	1.65	0.055	0.060	0.065
c	0.20	0.25	0.30	0.008	0.010	0.012
D	31.62	31.75	31.88	1.245	1.250	1.255
E	7.62		8.26	0.300		0.325
E1	6.35	6.60	6.86	0.250	0.260	0.270
e		2.54			0.100	
E1		7.62			0.300	
L	3.18		3.43	0.125		0.135
M	0°		15°	0°		15°



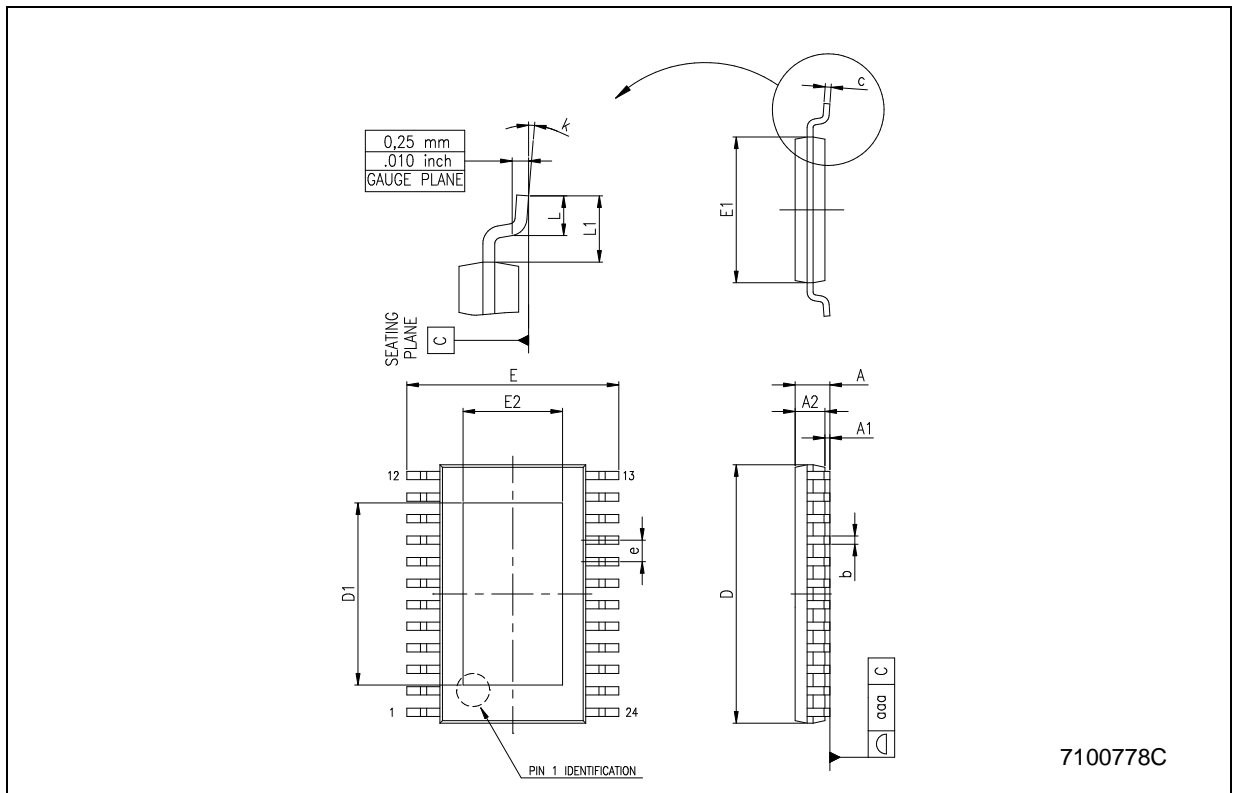
SO-24 MECHANICAL DATA

DIM.	mm.			inch		
	MIN.	TYP.	MAX.	MIN.	TYP.	MAX.
A	2.35		2.65	0.093		0.104
A1	0.1		0.30	0.004		0.012
B	0.33		0.51	0.013		0.020
C	0.23		0.32	0.009		0.013
D	15.20		15.60	0.598		0.614
E	7.4		7.6	0.291		0.299
e		1.27			0.050	
H	10.00		10.65	0.394		0.419
h	0.25		0.75	0.010		0.030
L	0.4		1.27	0.016		0.050
k	0°		8°	0°		8°
ddd			0.100			0.004



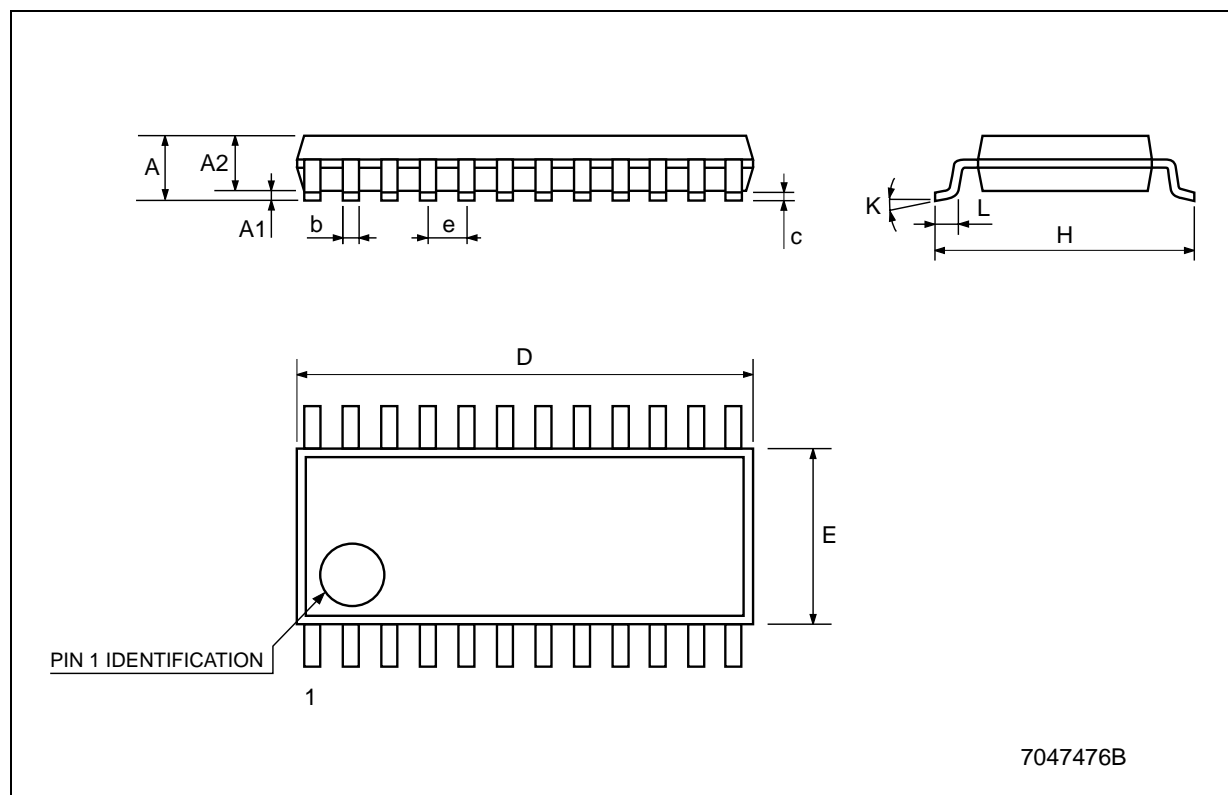
TSSOP24 EXPOSED PAD MECHANICAL DATA

DIM.	mm.			inch		
	MIN.	TYP	MAX.	MIN.	TYP.	MAX.
A			1.2			0.047
A1			0.15		0.004	0.006
A2	0.8	1	1.05	0.031	0.039	0.041
b	0.19		0.30	0.007		0.012
c	0.09		0.20	0.004		0.0089
D	7.7	7.8	7.9	0.303	0.307	0.311
D1	2.7			0.106		
E	6.2	6.4	6.6	0.244	0.252	0.260
E1	4.3	4.4	4.5	0.169	0.173	0.177
E2	1.5			0.059		
e		0.65			0.0256	
K	0°		8°	0°		8°
L	0.45	0.60	0.75	0.018	0.024	0.030



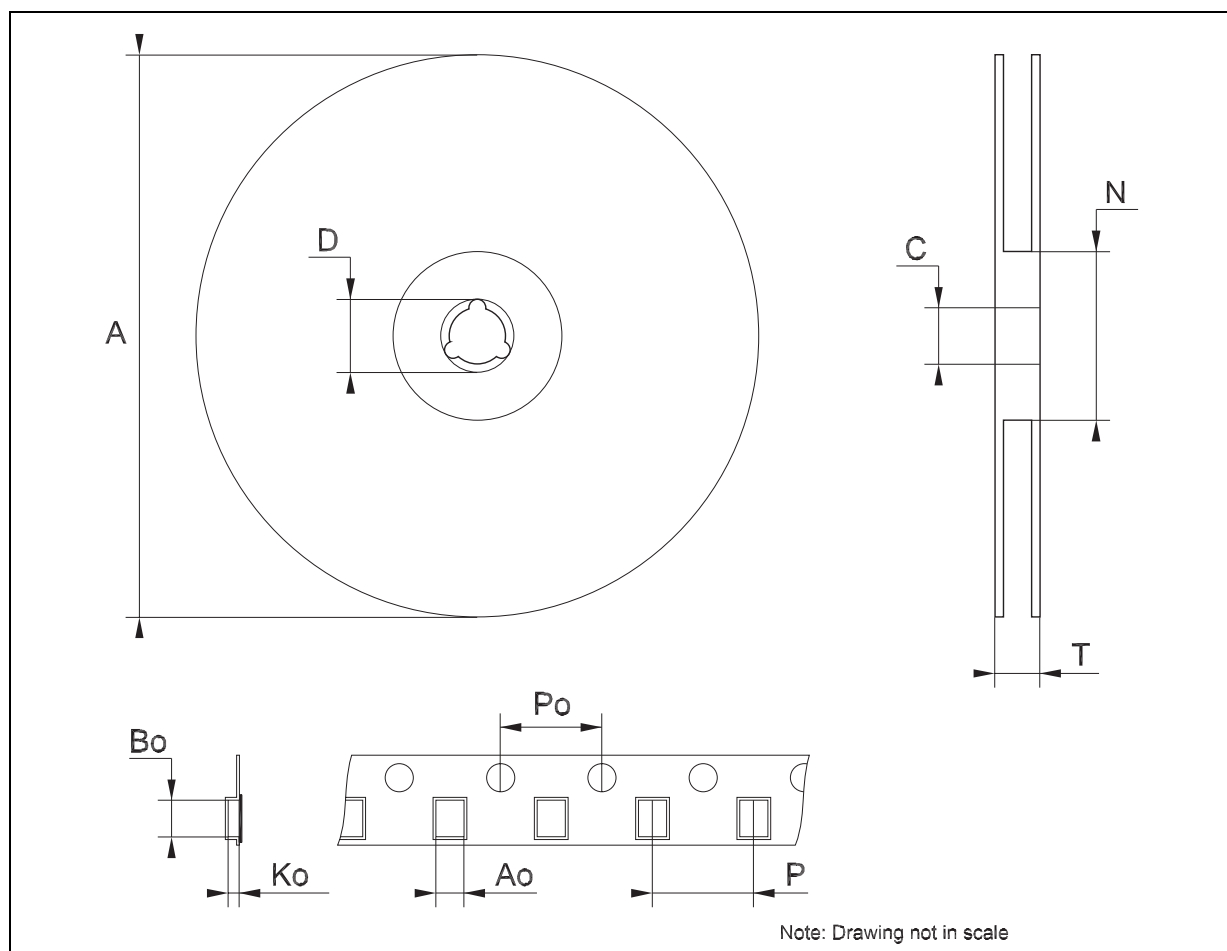
TSSOP24 MECHANICAL DATA

DIM.	mm.			inch		
	MIN.	TYP.	MAX.	MIN.	TYP.	MAX.
A			1.1			0.043
A1	0.05		0.15	0.002		0.006
A2		0.9			0.035	
b	0.19		0.30	0.0075		0.0118
c	0.09		0.20	0.0035		0.0079
D	7.7		7.9	0.303		0.311
E	4.3		4.5	0.169		0.177
e		0.65 BSC			0.0256 BSC	
H	6.25		6.5	0.246		0.256
K	0°		8°	0°		8°
L	0.50		0.70	0.020		0.028



Tape & Reel SO-24 MECHANICAL DATA

DIM.	mm.			inch		
	MIN.	TYP	MAX.	MIN.	TYP.	MAX.
A			330			12.992
C	12.8		13.2	0.504		0.519
D	20.2			0.795		
N	60			2.362		
T			30.4			1.197
Ao	10.8		11.0	0.425		0.433
Bo	15.7		15.9	0.618		0.626
Ko	2.9		3.1	0.114		0.122
Po	3.9		4.1	0.153		0.161
P	11.9		12.1	0.468		0.476



Tape & Reel TSSOP24 MECHANICAL DATA

DIM.	mm.			inch		
	MIN.	TYP	MAX.	MIN.	TYP.	MAX.
A			330			12.992
C	12.8		13.2	0.504		0.519
D	20.2			0.795		
N	60			2.362		
T			22.4			0.882
Ao	6.8		7	0.268		0.276
Bo	8.2		8.4	0.323		0.331
Ko	1.7		1.9	0.067		0.075
Po	3.9		4.1	0.153		0.161
P	11.9		12.1	0.468		0.476

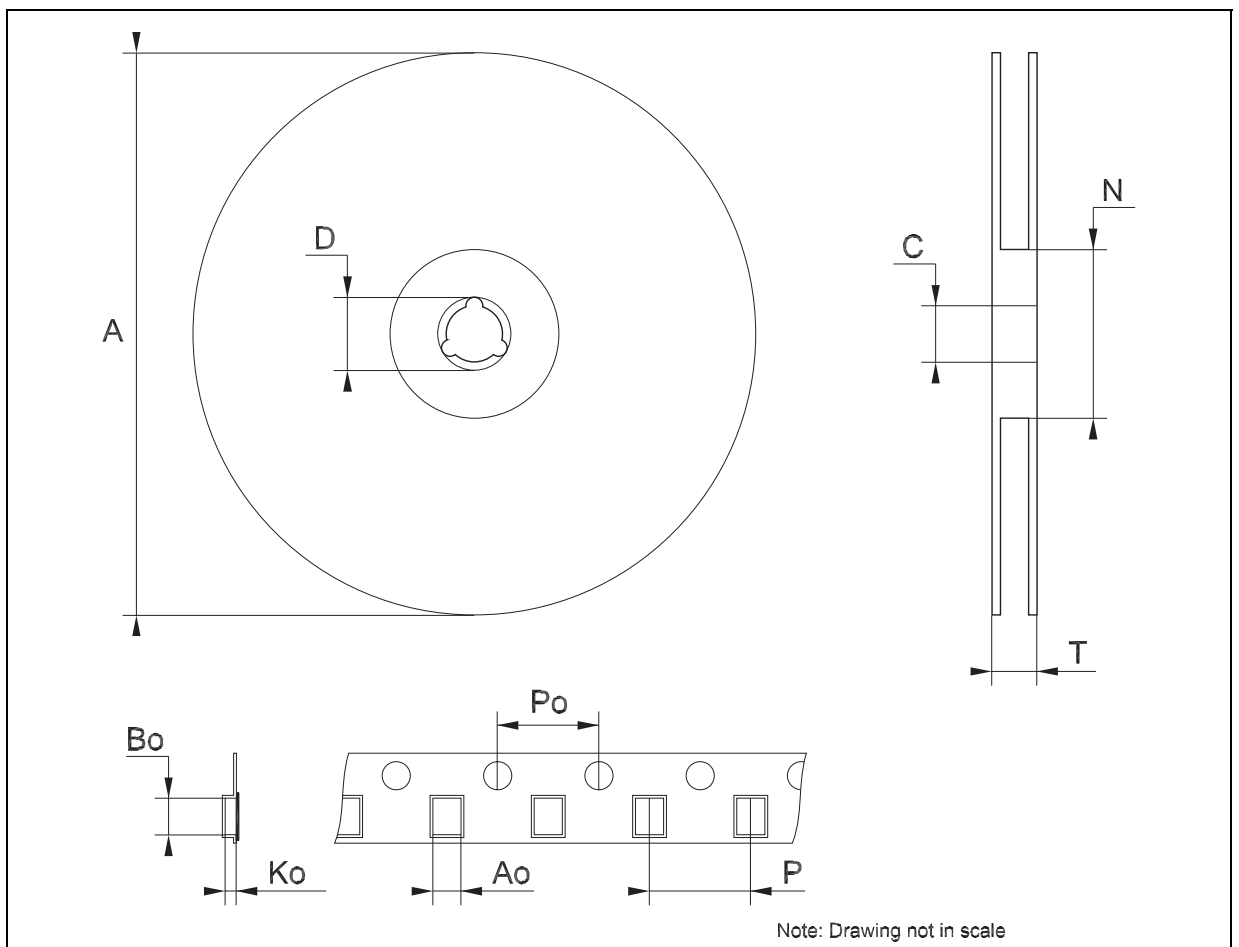


Table 10: Revision History

Date	Revision	Description of Changes
08-Apr-2005	1	First Release.
02-May-2005	2	Typing Error on the description features.
25-Jul-2005	3	Add note on Fig. 1 and Table 5.

Information furnished is believed to be accurate and reliable. However, STMicroelectronics assumes no responsibility for the consequences of use of such information nor for any infringement of patents or other rights of third parties which may result from its use. No license is granted by implication or otherwise under any patent or patent rights of STMicroelectronics. Specifications mentioned in this publication are subject to change without notice. This publication supersedes and replaces all information previously supplied. STMicroelectronics products are not authorized for use as critical components in life support devices or systems without express written approval of STMicroelectronics.

The ST logo is a registered trademark of STMicroelectronics

All other names are the property of their respective owners

© 2005 STMicroelectronics - All Rights Reserved

STMicroelectronics group of companies

Australia - Belgium - Brazil - Canada - China - Czech Republic - Finland - France - Germany - Hong Kong - India - Israel - Italy - Japan - Malaysia - Malta - Morocco - Singapore - Spain - Sweden - Switzerland - United Kingdom - United States of America

www.st.com