

To all our customers

---

## **Regarding the change of names mentioned in the document, such as Mitsubishi Electric and Mitsubishi XX, to Renesas Technology Corp.**

---

The semiconductor operations of Hitachi and Mitsubishi Electric were transferred to Renesas Technology Corporation on April 1st 2003. These operations include microcomputer, logic, analog and discrete devices, and memory chips other than DRAMs (flash memory, SRAMs etc.) Accordingly, although Mitsubishi Electric, Mitsubishi Electric Corporation, Mitsubishi Semiconductors, and other Mitsubishi brand names are mentioned in the document, these names have in fact all been changed to Renesas Technology Corp. Thank you for your understanding. Except for our corporate trademark, logo and corporate statement, no changes whatsoever have been made to the contents of the document, and these changes do not constitute any alteration to the contents of the document itself.

Note : Mitsubishi Electric will continue the business operations of high frequency & optical devices and power devices.

Renesas Technology Corp.  
Customer Support Dept.  
April 1, 2003

## DESCRIPTION

M66014 Semiconductor Integrated Circuit is a serial bus controller. It converts 2-byte parallel data that arrives from microcomputer into serial and outputs it to serial bus. It also converts serial data input from serial bus into parallel and outputs it to microcomputer.

The M66014 is used for the extension of microcomputer I/O ports and two-way communication with peripheral equipment connected with serial buses.

## FEATURES

- Compatible with general-purpose 8-bit microprocessor buses
- TTL level input (one microcomputer side)
- Interrupt output
- Schmitt input (RESET, CS, SIN)
- Pin arrangement is fully compatible with M66011FP
- Low power dissipation
- Wide operating temperature range (Ta = -20 to 75°C)

## APPLICATION

Microcomputer I/O port extension, etc.

## PIN CONFIGURATION (TOP VIEW)

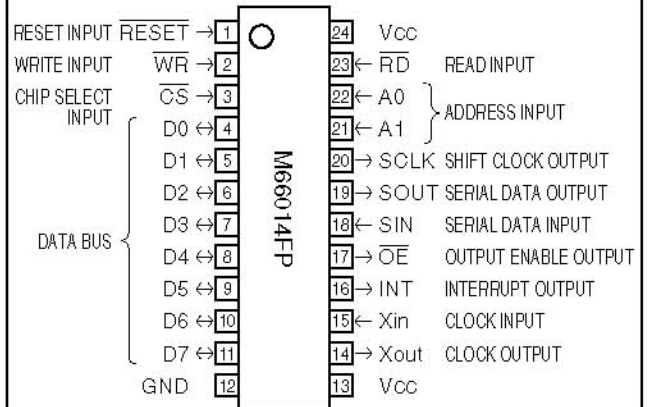

Outline 24P2N-B

## BLOCK DIAGRAM

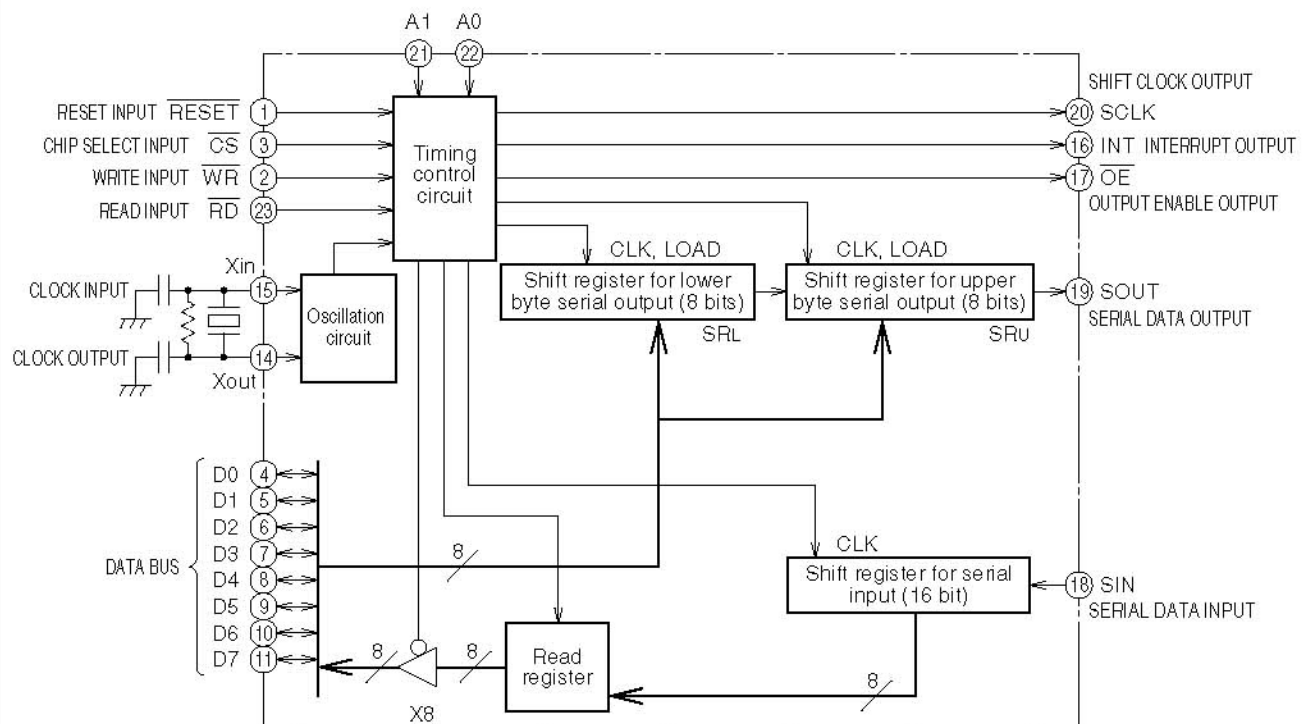

**Serial data input/output operation**

A cycle of 16-bit serial output data setting and serial data communication starts with a write access given by micro-computer to transmission shift registers in M66014.

M66014 has two 8-bit shift registers, one for upper byte (SRU), the other for lower byte (SRL). If the  $\overline{CS}$  status rises from "L" to "H" after a write access is given to SRL, serial data communication is started. SRU 8-bit data and SRL 8-bit data are output in series in this order. Output of each data starts from its most significant bit.

At the  $\overline{CS}$  rise edge, busy flag in M66014 is set, and  $\overline{OE}$  output shifts from "H" to "L". Shift clock SCLK and serial data SOUT are then output.

At SCLK fall edges, serial output shift register executes shifting operation, and data on shift register is output in series from pin SOUT. Serial input data from pin SIN is taken into input shift register at SCLK rise edges.

After the SCLK 16T rise edge, the status of SOUT and  $\overline{OE}$  shifts to "H" after one bit's delay of SCLK, and busy flag is reset. When interrupt output is being set to enable, INT output is set.

**(Remarks)**

- (1) If  $\overline{CS}$  rises after write operation is executed on SRL only and not on SRU, SRU data is unstable.
- (2) When write operations executed on SRL, M66014 becomes ready for start of serial communication and stands by for detection of  $\overline{CS}$  rise. However, if a read access is given after data is written on SRL while  $\overline{CS}$  is maintained on "L" level, this standby status is canceled. To resume serial communication in this case, rewrite data on SRL and raise  $\overline{CS}$ .

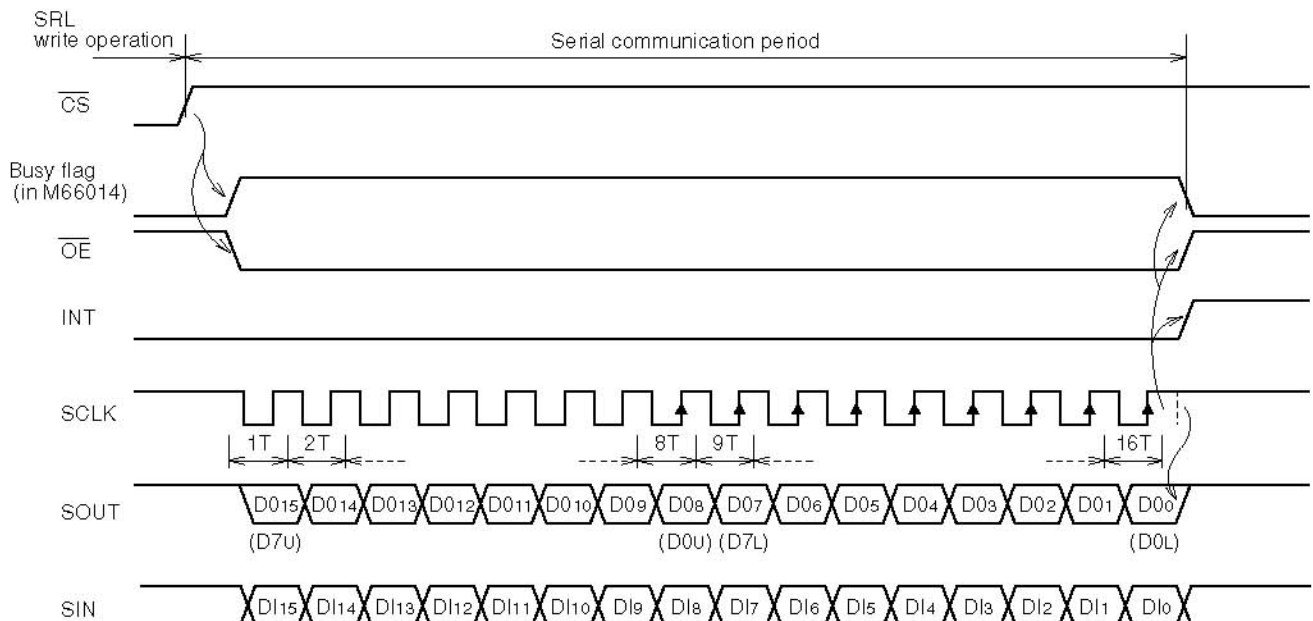

Serial Communication Timing Chart