



## SINGLE-CHIP SET-TOP BOX WITH DOCSIS® 1.1 AND PVR

### FEATURES

- Dual 1024/256/64-QAM variable symbol rate receivers supporting ITU-T J.83 Annex A/B/C
- QPSK out-of-band receiver and a QPSK to 256-QAM upstream burst modulator
- DOCSIS® 1.1 MAC supporting quality of service (QoS)
- DAVIC 1.2/1.5 MAC
- Dolby AC-3/Musicam® audio decoding
- Advanced 2D/3D graphics engine
- Dual NTSC/PAL video decoders
- NTSC/PAL video encoder
- BTSC decoder
- External bus interface (EBI) serving as local bus
- High-performance 250-MHz RISC MIPS32™ processor with 16-KB I cache and 16-KB D cache
- USB host and device (OHCI)
- Ethernet 10/100 MAC
- Personal video recording (PVR) with IDE controller, 3DES, and dedicated DMA engines
- On-board DES/DVB decryption
- Single unified memory architecture
- Software device drivers supporting multiple operating systems and middlewares
- BCM7041 dual-MPEG encoder interface
- Other peripheral devices include IEEE 1394 interface, POD interface, V.90 softmodem support, LED and UARTs

### SUMMARY OF BENEFITS

- Integrated front-end and back-end results in the most cost-effective single-chip set-top box solution with personal video recording (PVR) and DOCSIS 1.1
- PVR engine supports time shifting on a program being viewed and recording of another program simultaneously (watch and record)
- Dual tuner architecture allows for simultaneous viewing of internet and video or two independent program streams for watch and record PVR
- DOCSIS 1.1 quality of service (QoS) enables applications requiring minimum bandwidths, such as VoIP and video conferencing
- Support for DOCSIS 1.1, DAVIC 1.2/1.5, and DCII enables deployment in virtually all major markets worldwide
- Single high-performance RISC processor is capable of supporting today's demanding set-top box operating systems, applications, and cable modem traffic
- External QAM demodulator support for simultaneous DOCSIS and PVR watch and record

### Single-Chip Set-top Box with DOCSIS® 1.1 and PVR System Block Diagram

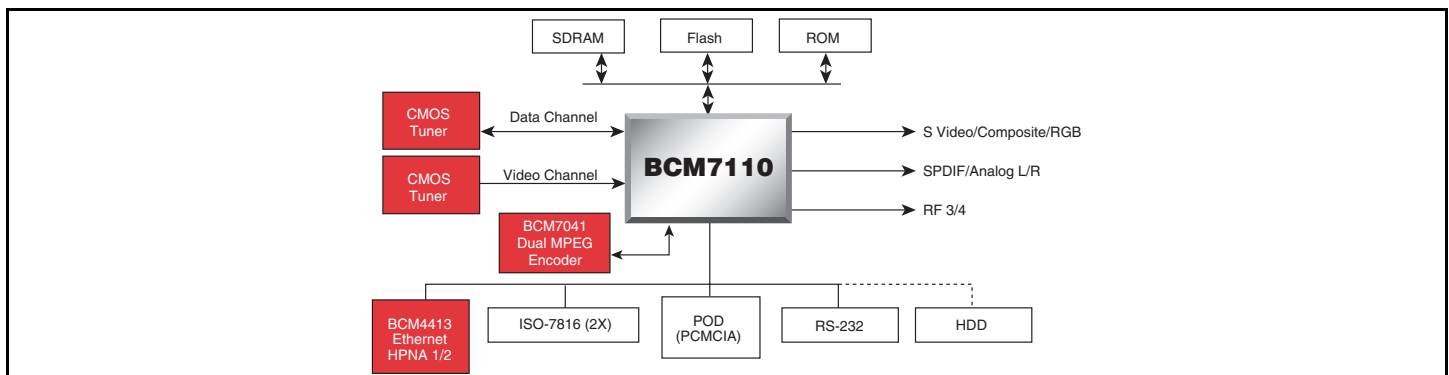

# OVERVIEW

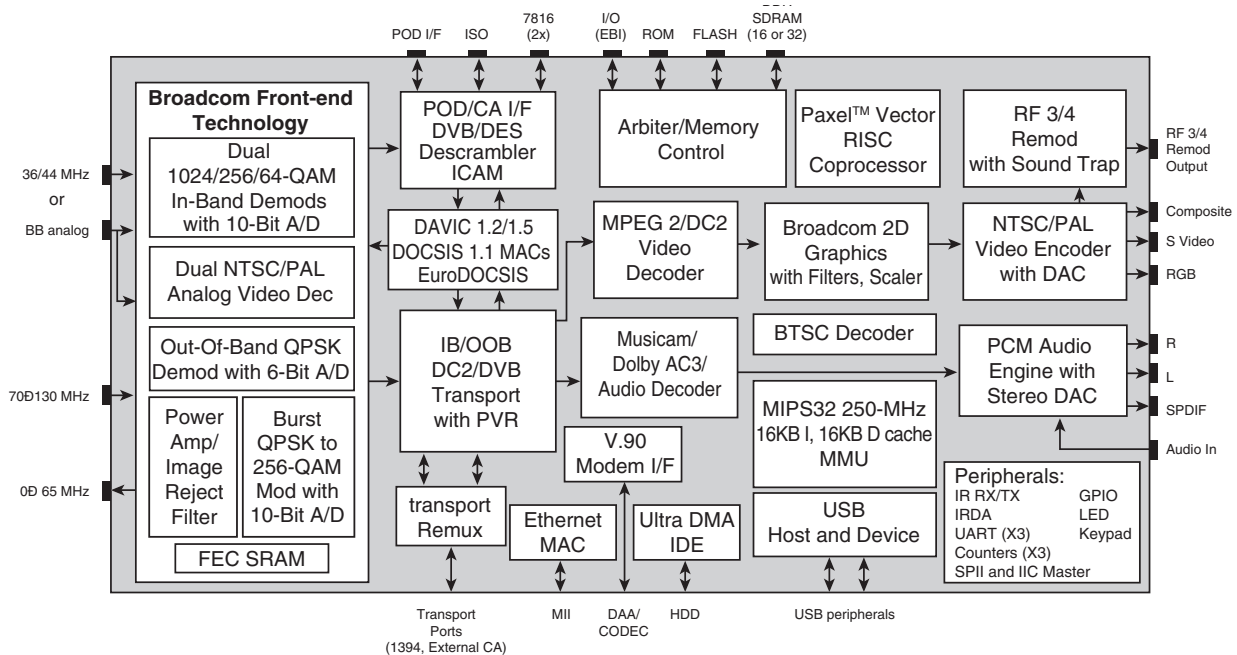

The BCM7110 is a single-chip set-top box device that combines the key aspects required for the next generation of set-top boxes including cost-effective single-chip design, personal video recording (PVR), broadband communication via DOCSIS 1.1 cable modem, and support of all major global standards for worldwide deployment.

The BCM7110 includes dual 1024/256/64-QAM receivers, an out-of-band QPSK receiver and a QPSK to 256-QAM upstream burst modulator. All major physical layer standards are supported for deployment worldwide. The device includes a complete DOCSIS 1.1 MAC (including QoS) for broadband interactive services and DAVIC 1.2/1.5 MAC.

The BCM7110 also includes a standard definition MPEG-2 video decoder and 2D/3D graphics subsystem. This allows for the display of studio quality text/graphics and 3D effects. The DVB/DCII transport of the device supports PVR. This support includes time shifting on the program being viewed and recording of another program simultaneously.

A full PCM audio engine for mixing sounds into the main audio stream is also on-chip. Outputs include left and right analog and SPDIF.

The BCM7110 also contains a high-performance MIPS32 RISC processor with 16-KB I cache and 16-KB D cache.

The BCM7110 includes a number of peripherals required for next-generation set-top boxes, including USB host and device, Ethernet, IDE controller for connection to disk drives, POD interface for external conditional access, PCMCIA interface, and a glueless IEEE 1394 interface. The BCM7110 also contains support for the Broadcom V.90 softmodem.

On-board descrambling supports all major conditional access systems and includes 3DES encryption/decryption for PVR.

The BCM7110 represents the most integrated, cost-effective set-top box single-chip solution incorporating next-generation requirements. It is built on the previous generation of Broadcom silicon and software to offer a low risk and quick time-to-market for interactive broadband set-top boxes.

Broadcom®, the pulse logo, and Connecting everything® are trademarks of Broadcom Corporation and/or its subsidiaries in the United States and certain other countries. All other trademarks mentioned are the property of their respective owners.

Connecting  
everything®



**BROADCOM CORPORATION**  
16215 Alton Parkway, P.O. Box 57013  
Irvine, California 92619-7013

© 2003 by BROADCOM CORPORATION. All rights reserved.

Phone: 949-450-8700  
Fax: 949-450-8710  
E-mail: info@broadcom.com  
Web: www.broadcom.com