

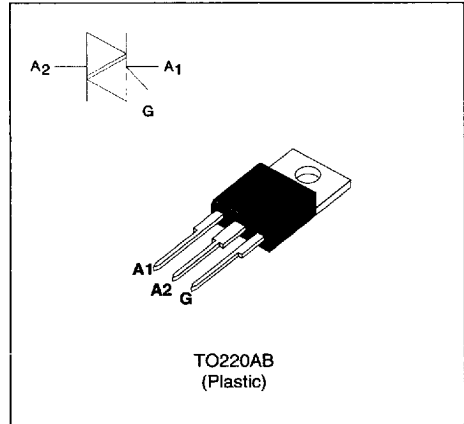
**SENSITIVE GATE TRIACS**

**FEATURES**

- VERY LOW  $I_{GT} = 10\text{mA max}$
- LOW  $I_H = 15\text{mA max}$
- BTA Family :  
INSULATING VOLTAGE = 2500V(RMS)  
(UL RECOGNIZED : E81734)

**DESCRIPTION**

The BTA/BTB06 T/D/S/A triac family are high performance glass passivated PNP devices. These parts are suitable for general purpose applications where gate high sensitivity is required. Application on 4Q such as phase control and static switching.



**ABSOLUTE RATINGS** (limiting values)

Symbol	Parameter		Value	Unit	
$I_T(\text{RMS})$	RMS on-state current (360° conduction angle)	BTA	$T_c = 85^\circ\text{C}$	6	A
		BTB	$T_c = 90^\circ\text{C}$		
$I_{TSM}$	Non repetitive surge peak on-state current ( $T_j$ initial = $25^\circ\text{C}$ )		$t_p = 8.3 \text{ ms}$	63	A
			$t_p = 10 \text{ ms}$	60	
$I_2t$	$I_2t$ value		$t_p = 10 \text{ ms}$	18	$\text{A}^2\text{s}$
$di/dt$	Critical rate of rise of on-state current Gate supply : $I_G = 50\text{mA}$ $di_G/dt = 0.1\text{A}/\mu\text{s}$		Repetitive $F = 50 \text{ Hz}$	10	$\text{A}/\mu\text{s}$
			Non Repetitive	50	
$T_{stg}$ $T_j$	Storage and operating junction temperature range		- 40 to + 150		$^\circ\text{C}$
			- 40 to + 110		$^\circ\text{C}$
$T_l$	Maximum lead temperature for soldering during 10 s at 4.5 mm from case			260	$^\circ\text{C}$

Symbol	Parameter	BTA / BTB06-			Unit
		400 T/D/S/A	600 T/D/S/A	700 T/D/S/A	
$V_{DRM}$ $V_{RRM}$	Repetitive peak off-state voltage $T_j = 110^\circ\text{C}$	400	600	700	V

**THERMAL RESISTANCES**

Symbol	Parameter	Value	Unit
Rth (j-a)	Junction to ambient	60	°C/W
Rth (j-c) DC	Junction to case for DC	BTA	4.4
		BTB	3.2
Rth (j-c) AC	Junction to case for 360° conduction angle ( F = 50 Hz)	BTA	3.3
		BTB	2.4

**GATE CHARACTERISTICS** (maximum values)

PG (AV) = 1W    PGM = 10W (tp = 20 μs)    IGM = 4A (tp = 20 μs)    VGM = 16V (tp = 20 μs).

**ELECTRICAL CHARACTERISTICS**

Symbol	Test Conditions	Quadrant		Suffix				Unit	
				T	D	S	A		
IGT	VD=12V (DC) RL=33Ω	Tj=25°C	I-II-III	MAX	5	5	10	10	mA
			IV	MAX	5	10	10	25	
VGT	VD=12V (DC) RL=33Ω	Tj=25°C	I-II-III-IV	MAX	1.5				V
VGD	VD=VDRM RL=3.3kΩ	Tj=110°C	I-II-III-IV	MIN	0.2				V
tgt	VD=VDRM IG = 40mA dIG/dt = 0.5A/μs	Tj=25°C	I-II-III-IV	TYP	2				μs
IL	IG= 1.2 IGT	Tj=25°C	I-III-IV	TYP	10	10	20	20	mA
			II		20	20	40	40	
IH *	IT= 100mA gate open	Tj=25°C		MAX	15	15	25	25	mA
VTM *	ITM= 8.5A tp= 380μs	Tj=25°C		MAX	1.65				V
IDRM IRRM	VDRM Rated VRRM Rated	Tj=25°C		MAX	0.01				mA
		Tj=110°C		MAX	0.75				
dV/dt *	Linear slope up to VD=67%VDRM gate open	Tj=110°C		TYP	10	10	-	-	V/μs
				MIN	-	-	10	10	
(dV/dt)c *	(dI/dt)c = 2.7A/ms	Tj=110°C		TYP	1	1	5	5	V/μs

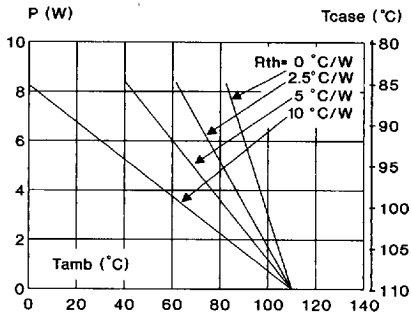
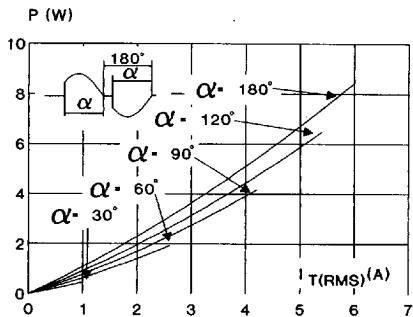
\* For either polarity of electrode A2 voltage with reference to electrode A1.

ORDERING INFORMATION

Package	$I_T(RMS)$	$V_{DRM} / V_{RRM}$	Sensitivity Specification			
	A	V	T	D	S	A
BTA (Insulated)	6	400	X	X	X	X
		600	X	X	X	X
		700	X	X	X	X
BTB (Uninsulated)	6	400	X	X	X	X
		600	X	X	X	X
		700	X	X	X	X

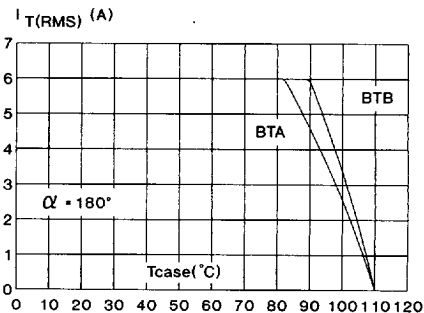
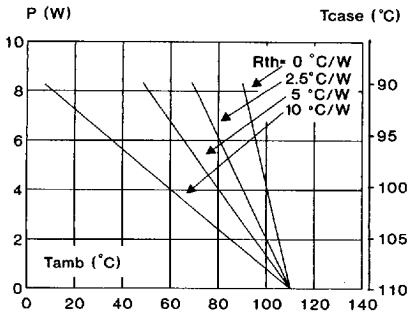
**Fig.1 :** Maximum RMS power dissipation versus RMS on-state current ( $F=50Hz$ ).  
(Curves are cut off by  $(di/dt)c$  limitation)

**Fig.2 :** Correlation between maximum RMS power dissipation and maximum allowable temperatures ( $T_{amb}$  and  $T_{case}$ ) for different thermal resistances heatsink + contact (BTA).

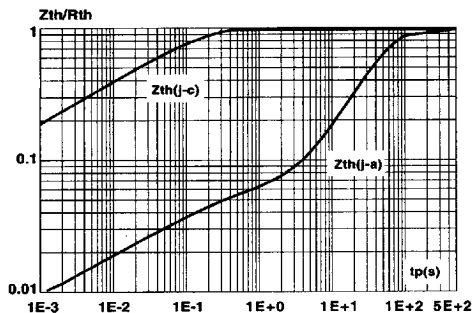


**Fig.3 :** Correlation between maximum RMS power dissipation and maximum allowable temperatures ( $T_{amb}$  and  $T_{case}$ ) for different thermal resistances heatsink + contact (BTB).

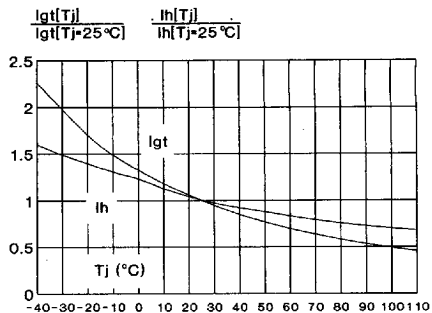
**Fig.4 :** RMS on-state current versus case temperature.



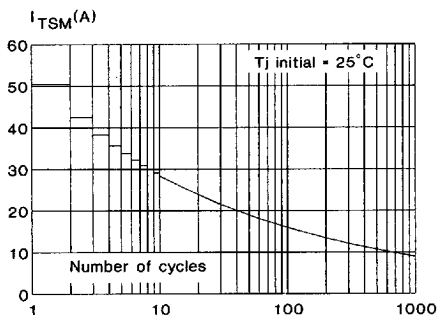
**Fig.5 :** Relative variation of thermal impedance versus pulse duration.



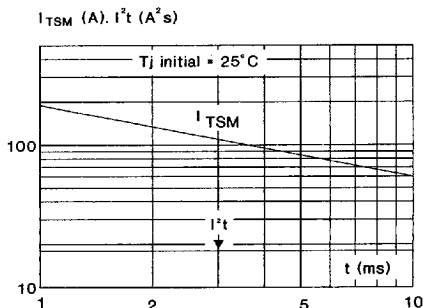
**Fig.6 :** Relative variation of gate trigger current and holding current versus junction temperature.



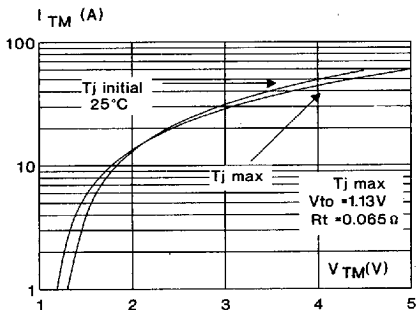
**Fig.7 :** Non Repetitive surge peak on-state current versus number of cycles.



**Fig.8 :** Non repetitive surge peak on-state current for a sinusoidal pulse with width :  $t \leq 10\text{ms}$ , and corresponding value of  $I^2t$ .

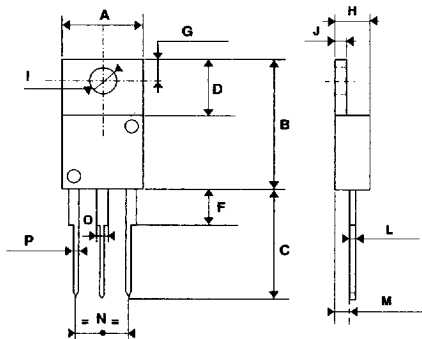


**Fig.9 :** On-state characteristics (maximum values).



## PACKAGE MECHANICAL DATA

TO220AB Plastic



REF.	DIMENSIONS			
	Millimeters		Inches	
	Min.	Max.	Min.	Max.
A	10.20	10.50	0.401	0.413
B	14.23	15.87	0.560	0.625
C	12.70	14.70	0.500	0.579
D	5.85	6.85	0.230	0.270
F		4.50		0.178
G	2.54	3.00	0.100	0.119
H	4.48	4.82	0.176	0.190
I	3.55	4.00	0.140	0.158
J	1.15	1.39	0.045	0.055
L	0.35	0.65	0.013	0.026
M	2.10	2.70	0.082	0.107
N	4.58	5.58	0.18	0.22
O	0.80	1.20	0.031	0.048
P	0.64	0.96	0.025	0.038

Cooling method : C

Marking : type number

Weight : 2.3 g

Recommended torque value : 0.8 m.N.

Maximum torque value : 1 m.N.