



# MH103A

High Dynamic Range 1.9 – 2.7 GHz MMIC Mixer



## Product Features

- +34 dBm IIP3
- RF: 1900 – 2700 MHz
- LO: 1600 – 2650 MHz
- IF: 50 – 300 MHz
- +17 dBm Drive Level
- Lead-free/green/RoHS-compliant SOIC-8 SMT package
- No External Bias Required

## Applications

- Mobile Infrastructure
- WiBro / WiMAX Infrastructure

## Product Description

The MH103A is a passive GaAs MESFET mixer that provides high dynamic range performance in a low-cost lead-free/green/RoHS-compliant SOIC-8 package. WJ's MH103A uses patented techniques to realize +34 dBm Input IP3 at an LO drive level of +17 dBm and can be used for upconverting or downconverting low-side LO applications.

This single monolithic integrated circuit does not require any external baluns, bias, matching, or decoupling elements. The on-chip diplexer affords good matching on the RF and IF ports.

Typical applications include frequency up/down conversion, modulation and demodulation for receivers and transmitters used in 3G UMTS systems.

## Functional Diagram

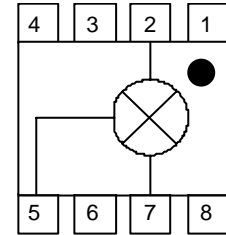

Function	Pin No.
LO	2
IF	5
RF	7
GND	1, 3, 4, 6, 8

## Specifications <sup>(1)</sup>

Parameter	Units	Min	Typ	Max	Comments
RF Frequency Range	MHz		1900 – 2700		
LO Frequency Range	MHz		1600 – 2650		
IF Frequency Range	MHz		50 – 300		
SSB Conversion Loss	dB		8.2	9.0	See note 1
Noise Figure	dB		8.7		See note 2
Input IP3	dBm	+28	+34		See note 1, 3
Input P1dB	dBm		+16		
LO – RF Isolation	dB	21	28		
LO – IF Isolation	dB	27	37		
RF – IF Isolation	dB	12	18		
Return Loss: RF Port	dB		15		
Return Loss: IF Port	dB		20		
Return Loss: LO Port	dB		12		
LO Drive Level	dBm		+17		

1. Specifications are guaranteed at: RF / IF = 1900 / 50, 1900 / 200, 2200 / 50, and 2200 / 300 MHz with a low-side LO at +17 dBm in a downconverting application at 25 °C.  
 2. Assumes LO injection noise is filtered at the thermal noise floor, -174 dBm/Hz, at the RF, IF, and Image frequencies.  
 3. IIP3 is measured with  $\Delta f = 1$  MHz with  $RF_{in} = 0$  dBm / tone.

## Absolute Maximum Rating

Parameter	Rating
Operating Case Temperature	-40 to +85 °C
Storage Temperature	-65 to +100 °C
LO Power	+20 dBm
Input IF / RF Power	+20 dBm

Operation of this device above any of these parameters may cause permanent damage.

## Ordering Information

Part No.	Description
MH103A-G	High Dynamic Range 1.9 – 2.7 GHz MMIC Mixer (lead-free/green/RoHS-compliant SOIC-8 package)
MH103A-PCB	Fully-Assembled Mixer Application Board

Specifications and information are subject to change without notice



# MH103A

High Dynamic Range 1.9 – 2.7 GHz MMIC Mixer



## Typical Performance Plots: Low-side Downconversion

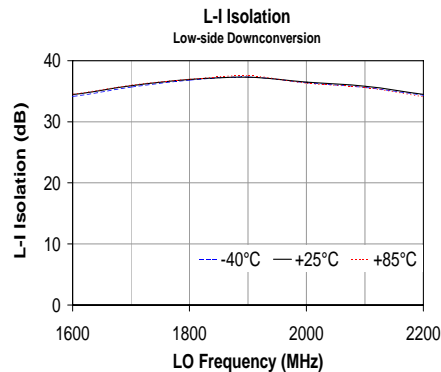
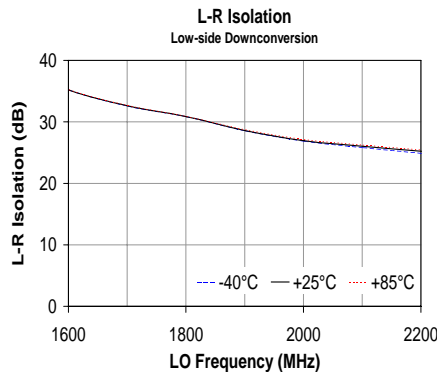
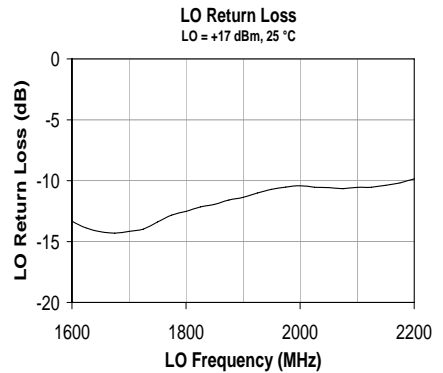
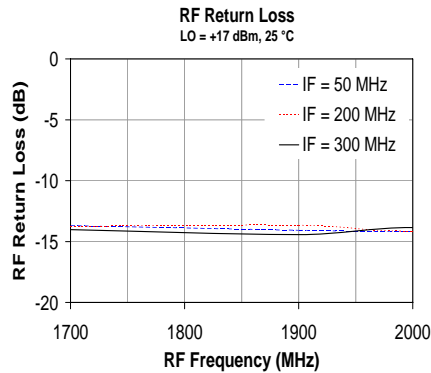
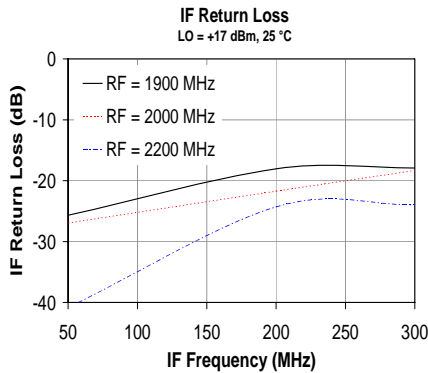
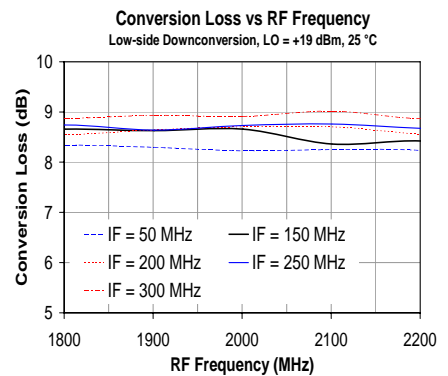
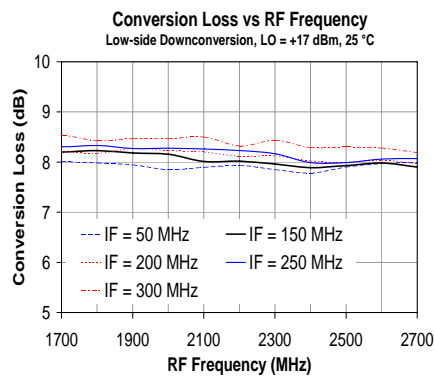
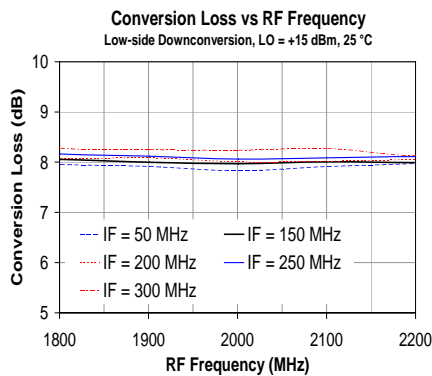
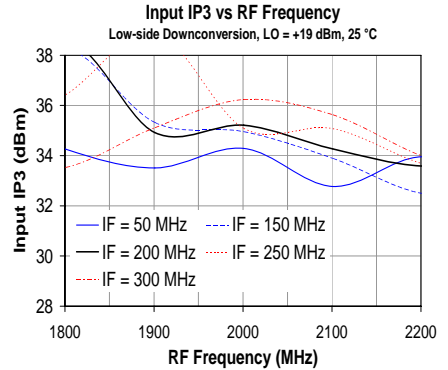
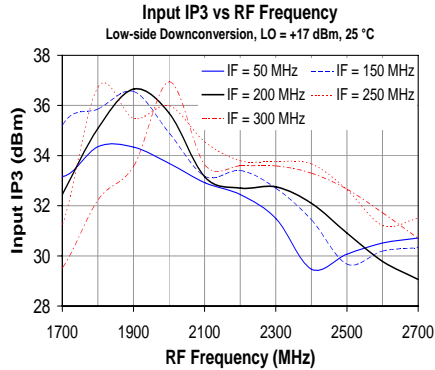
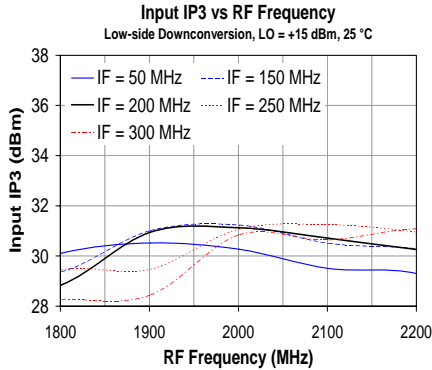

Specifications and information are subject to change without notice



# MH103A

## High Dynamic Range 1.9 – 2.7 GHz MMIC Mixer



### Typical Performance Plots over Temperature: Low-side Downconversion

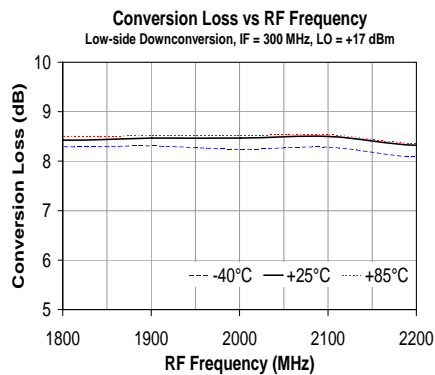
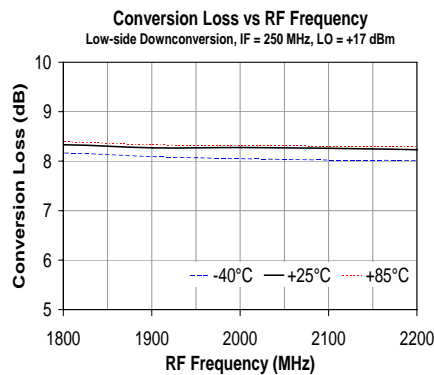
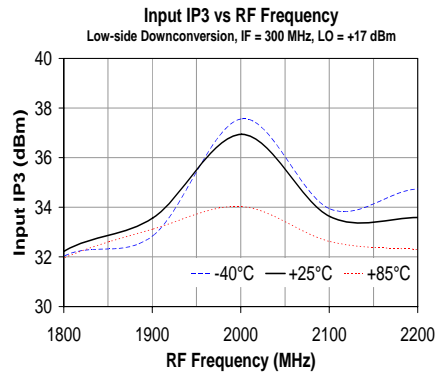
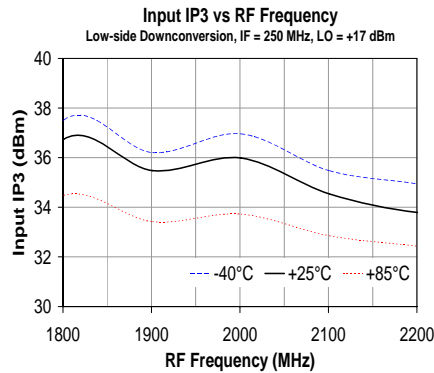
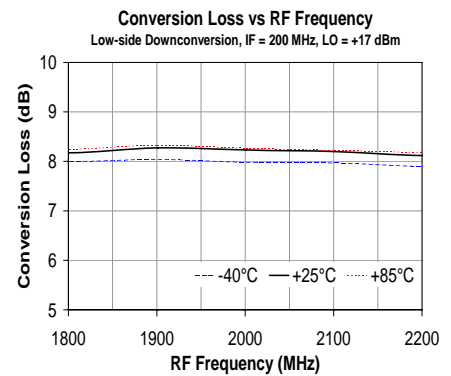
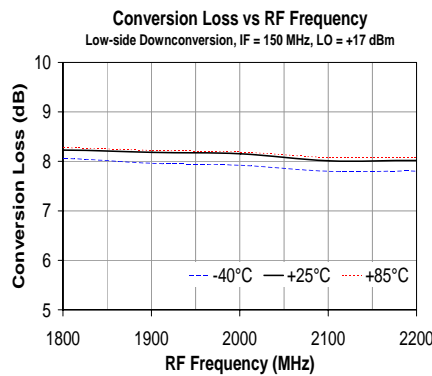
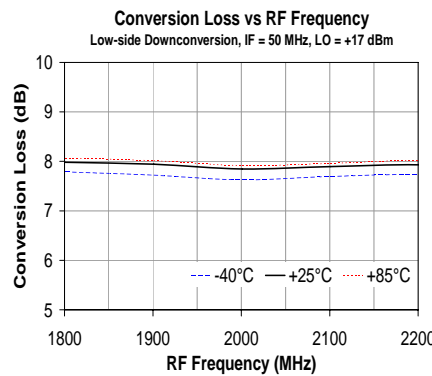
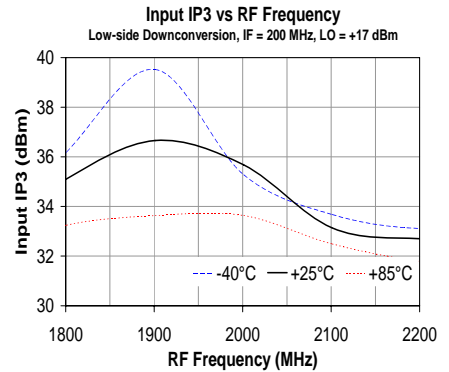
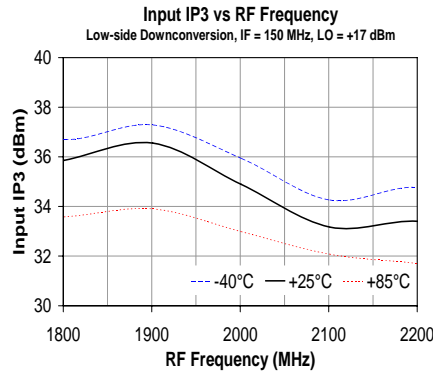
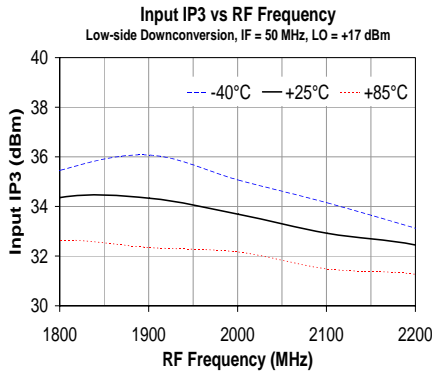

Specifications and information are subject to change without notice

## MH103A-G Mechanical Information

This package is lead-free/green/RoHS-compliant. The plating material on the leads is NiPdAu. It is compatible with both lead-free (maximum 260 °C reflow temperature) and tin-lead (maximum 245 °C reflow temperature) soldering processes.

## Application Circuit (MH103A-PCB)

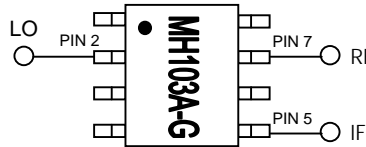

### Notes:

1. All other pins on mixer are grounded.
2. Circuit board material: .014" FR-4, 4 layers, .062" total thickness
3. Blocking capacitors are required on the ports (pins 2, 5, 7) if any dc signal is present.

## Outline Drawing

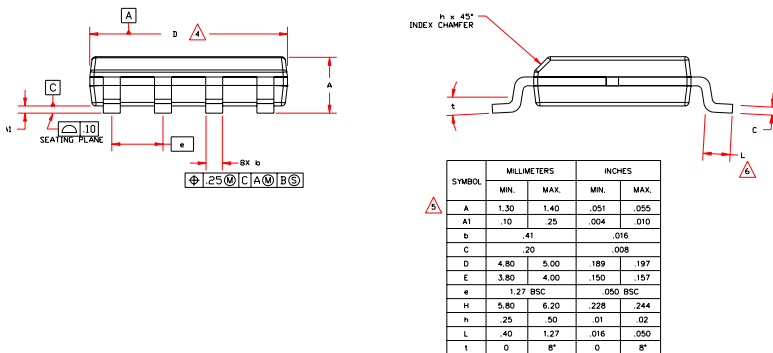
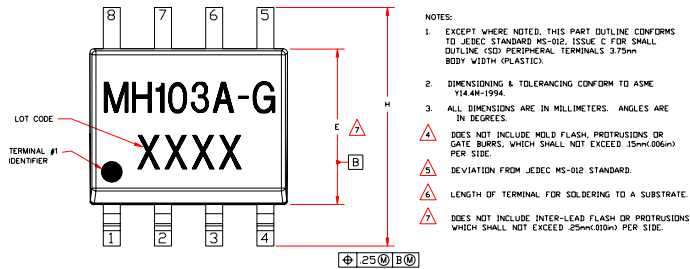

## Product Marking

The component will be marked with an "MH103A-G" designator followed by an alphanumeric lot code on the top surface of the package. The obsolete tin-lead package is marked with an "MH103A" designator followed by an alphanumeric lot code.

Tape and reel specifications for this part are located on the website in the "Application Notes" section.

## ESD / MSL Information



Caution! ESD sensitive device.

ESD Classification: Class 1B  
Value: Passes /500V to <1000 V  
Test: Human Body Model (HBM)  
Standard: JEDEC Standard JESD22-A114

ESD Classification: Class III  
Value: Passes /500 V to <1000 V  
Test: Charged Device Model (CDM)  
Standard: JEDEC Standard JESD22-C101

MSL Rating: Level 2 at +260 °C convection reflow  
Standard: JEDEC Standard J-STD-020B

## Land Pattern / Mounting Configuration

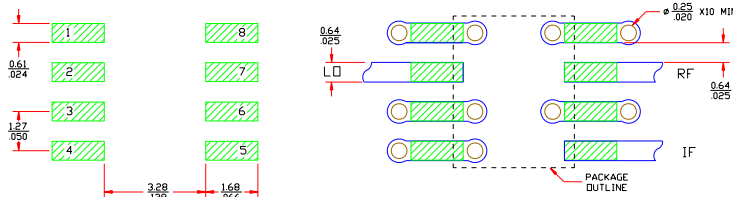

- Notes:
1. Ground vias are critical for RF grounding considerations.
  2. A minimum of 10 ground vias are required for 14 mil and 28 mil FR4 board.
  3. Trace width depends on PC board.

## Functional Pin Layout

Pin	Function
1	Ground
2	LO Port
3	Ground
4	Ground
5	IF Port
6	Ground
7	RF Port
8	Ground