

Model 13 Medium Pressure



PC Board Mountable Pressure Sensor
0-100 mV Output
Gage and Absolute Pressure
Temperature Compensated

- ▶ Medical Instrumentation
- ▶ HVAC
- ▶ Barometric Pressure
- ▶ Process Control
- ▶ Vacuum Measurement
- ▶ Air Flow Management



DESCRIPTION

The Model 13 is a temperature compensated, piezoresistive silicon pressure sensor packaged in TO-8 configurations. It provides excellent performance and long-term stability.

Gage and absolute pressure ranges from 0-2 PSI to 0-250 PSI are available. Integral temperature compensation is provided over a range of 0-50°C using laser-trimmed resistors. An additional laser-trimmed resistor is included to normalize pressure sensitivity variations by programming the gain of an external differential amplifier. This provides sensitivity interchangeability of $\pm 1\%$.

Please refer to the low pressure section for information on products with operating pressures less than 0-2 PSI. For an uncompensated sensor (Model 10) please contact the factory for additional information.

FEATURES

- ▶ TO-8 Package
- ▶ $\pm 0.1\%$ Non-linearity
- ▶ $\pm 0.5\%$ Temperature Performance
- ▶ Solid State Reliability
- ▶ Low Power

STANDARD RANGES

Range	psig	psia
0 to 2	●	
0 to 5	●	●
0 to 10	●	●
0 to 15	●	●
0 to 30	●	●
0 to 50	●	●
0 to 100	●	●
0 to 250	●	●

DIMENSIONS

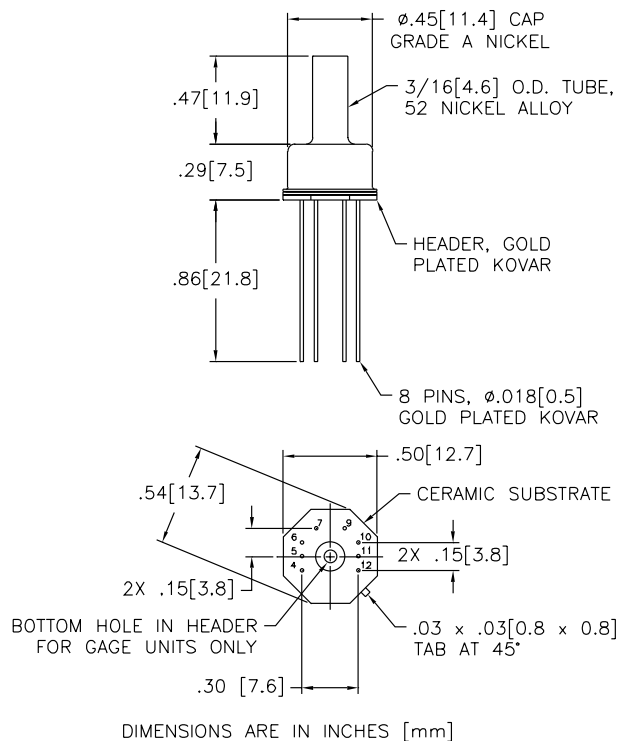

PERFORMANCE SPECIFICATIONS

Supply Current: 1.5mA
 Ambient Temperature: 25°C (Unless otherwise specified)

PARAMETERS	MIN	TYP	MAX	UNITS	NOTES
Full Scale Output Span	75	100	150	mV	
Full Scale Output Span (2 psi version)	30		60	mV	
Zero Pressure Output			2	±mV	
Pressure Non-linearity		0.05	0.10	±% Span	1
Pressure Hysteresis		0.01	0.05	±% Span	
Input & Output Resistance	2500	4400	6000	Ω	
Temperature Error – Span		0.3	0.5	±% Span	2
Temperature Error – Zero		0.1	0.5	±% Span	1, 2
Thermal Hysteresis – Span		0.1		±% Span	2
Thermal Hysteresis – Zero		0.1		±% Span	2
Supply Current		1.5	2.0	mA	3
Response Time		1.0		msec	4
Output Noise		1.0		μV p-p	5
Output Load Resistance	2			MΩ	6
Insulation Resistance (50 VDC)	50			MΩ	7
Pressure Overload			3X	Rated	8
Operating Temperature	-40°C to +125°C				
Storage Temperature	-50°C to +150°C				
Acceleration	50g Max				
Shock	1000g Peak for 0.5mS				
Vibration	20g Peak at 10 to 2000 Hz				
Media	Non-Corrosive Gases				9
Weight	3 Grams				

- Notes**
- Best Fit Straight Line. For 2 psi output span is 30-60 mV and TC zero temperature error is ± 1.25%.
 - Temperature range 0-50°C in reference to 25°C.
 - Guarantees input/output ratiometricity.
 - For a zero-to-full scale pressure step change.
 - 10 Hz to 1 kHz.
 - Prevents increase of TC Span due to output loading.
 - Between case and sensing element.
 - 3X not to exceed 500 psi on ranges: 0-10 psi to 0-250 psi; 20 psi for 2 psi and 5 psi versions.
 - For Top Entry versions, wetted materials are silicon, aluminum, gold, RTV, glass, and nickel. For Bottom Entry versions, wetted materials are silicon, RTV, gold, and glass.

CONNECTIONS

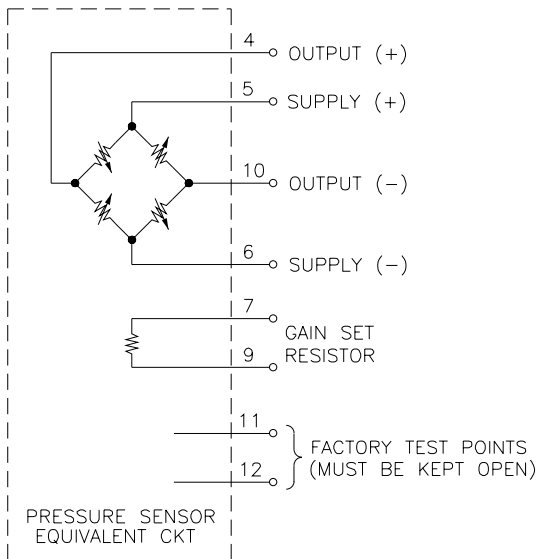

ORDERING INFORMATION

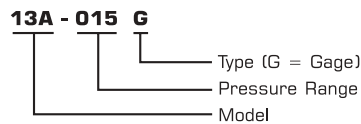

APPLICATION SCHEMATIC

