

User Manual



TG700 TV Signal Generator Platform

TG700 TV Signal Generator Platform

AG7 Audio Generator

AGL7 Analog Genlock Module

ATG7 Analog Test Generator

AVG7 Analog Video Generator

AWVG7 Analog Wideband Video Generator

BG7 Black Generator

DVG7 Digital Video Generator

HDLG7 HD Dual Link Video Generator

HDVG7 HDTV Digital Video Generator

070-A799-56

This document supports firmware version 4.3 and above.

www.tektronix.com

This volume contains the following user manuals:

- TG700 TV Signal Generator Platform User Manual
- AG7 Audio Generator User Manual
- AGL7 Analog Genlock Module User Manual
- ATG7 Analog Test Generator User Manual
- AVG7 Analog Video Generator User Manual
- AWVG7 Analog Wideband Video Generator User Manual
- BG7 Black Generator User Manual
- DVG7 Digital Video Generator User Manual
- HDLG7 HD Dual Link Video Generator User Manual
- HDVG7 HDTV Digital Video Generator User Manual

User Manual



TG700 TV Signal Generator Platform

Copyright © Tektronix. All rights reserved. Licensed software products are owned by Tektronix or its suppliers and are protected by United States copyright laws and international treaty provisions.

Tektronix products are covered by U.S. and foreign patents, issued and pending. Information in this publication supercedes that in all previously published material. Specifications and price change privileges reserved.

TEKTRONIX and TEK are registered trademarks of Tektronix, Inc.

Contacting Tektronix

Tektronix, Inc.
14200 SW Karl Braun Drive
P.O. Box 500
Beaverton, OR 97077
USA

For product information, sales, service, and technical support:

- In North America, call 1-800-833-9200.
- Worldwide, visit www.tektronix.com to find contacts in your area.

Warranty 2

Tektronix warrants that this product will be free from defects in materials and workmanship for a period of one (1) year from the date of shipment. If any such product proves defective during this warranty period, Tektronix, at its option, either will repair the defective product without charge for parts and labor, or will provide a replacement in exchange for the defective product. Parts, modules and replacement products used by Tektronix for warranty work may be new or reconditioned to like new performance. All replaced parts, modules and products become the property of Tektronix.

In order to obtain service under this warranty, Customer must notify Tektronix of the defect before the expiration of the warranty period and make suitable arrangements for the performance of service. Customer shall be responsible for packaging and shipping the defective product to the service center designated by Tektronix, with shipping charges prepaid. Tektronix shall pay for the return of the product to Customer if the shipment is to a location within the country in which the Tektronix service center is located. Customer shall be responsible for paying all shipping charges, duties, taxes, and any other charges for products returned to any other locations.

This warranty shall not apply to any defect, failure or damage caused by improper use or improper or inadequate maintenance and care. Tektronix shall not be obligated to furnish service under this warranty a) to repair damage resulting from attempts by personnel other than Tektronix representatives to install, repair or service the product; b) to repair damage resulting from improper use or connection to incompatible equipment; c) to repair any damage or malfunction caused by the use of non-Tektronix supplies; or d) to service a product that has been modified or integrated with other products when the effect of such modification or integration increases the time or difficulty of servicing the product.

THIS WARRANTY IS GIVEN BY TEKTRONIX IN LIEU OF ANY OTHER WARRANTIES, EXPRESS OR IMPLIED. TEKTRONIX AND ITS VENDORS DISCLAIM ANY IMPLIED WARRANTIES OF MERCHANTABILITY OR FITNESS FOR A PARTICULAR PURPOSE. TEKTRONIX' RESPONSIBILITY TO REPAIR OR REPLACE DEFECTIVE PRODUCTS IS THE SOLE AND EXCLUSIVE REMEDY PROVIDED TO THE CUSTOMER FOR BREACH OF THIS WARRANTY. TEKTRONIX AND ITS VENDORS WILL NOT BE LIABLE FOR ANY INDIRECT, SPECIAL, INCIDENTAL, OR CONSEQUENTIAL DAMAGES IRRESPECTIVE OF WHETHER TEKTRONIX OR THE VENDOR HAS ADVANCE NOTICE OF THE POSSIBILITY OF SUCH DAMAGES.

IMPORTANT

READ BEFORE OPERATING EQUIPMENT

This software is provided under license from Tektronix, Inc. Retention of this program for more than thirty (30) days or use of the program in any manner constitutes acceptance of the license terms.

CAREFULLY READ THE ENCLOSED SOFTWARE LICENSE AGREEMENT. If you cannot agree to the license terms, promptly contact the nearest Tektronix Field Office for return assistance.

TEKTRONIX SOFTWARE LICENSE AGREEMENT

THE PROGRAM, OR PROGRAMS, ENCODED OR INCORPORATED WITHIN EQUIPMENT, IS FURNISHED SUBJECT TO THE TERMS AND CONDITIONS OF THIS AGREEMENT. RETENTION OF THE PROGRAM FOR MORE THAN THIRTY DAYS OR USE OF THE PROGRAM IN ANY MANNER WILL BE CONSIDERED ACCEPTANCE OF THE AGREEMENT TERMS. IF THESE TERMS ARE NOT ACCEPTABLE, THE UNUSED PROGRAM AND ANY ACCOMPANYING DOCUMENTATION SHOULD BE RETURNED PROMPTLY TO TEKTRONIX FOR A FULL REFUND OF THE LICENSE FEE PAID. (FOR INFORMATION REGARDING THE RETURN OF PROGRAMS ENCODED OR INCORPORATED WITHIN EQUIPMENT, CONTACT THE NEAREST TEKTRONIX SALES OFFICE.)

DEFINITIONS. "Tektronix" means Tektronix, Inc., an Oregon corporation, or local Tektronix' legal entity that is supplying the equipment.

"Program" means the Tektronix software product (executable program and/or data) enclosed with this Agreement or included within the equipment with which this Agreement is packed.

"Customer" means the person or organization in whose name the Program was ordered.

LICENSE. Customer may:

- a. Use the Program on a single machine at any one time;
- b. If the Program is provided in connection with a floating-user license, the Program may be used on multiple machines provided that the user is authorized, and the total number of users at any one time does not exceed the total number of licensed concurrent users;
- c. Modify the Program or merge it with another for use on the single machine; and
- d. Copy the Program for archival or backup purposes, provided that no more than one (1) such copy is permitted to exist at any one time. If the Program is provided in connection with a floating-user license, the Program may be copied onto multiple machines for use by authorized users.

Each copy of the Program made by Customer must include a reproduction of any copyright notice or restrictive rights legend appearing in or on the copy of the Program as received from Tektronix.

Customer may not:

- a. Use the Program on more than one machine at any one time, unless covered by a floating-user license or separate site license;
- b. Transfer the Program to any person or organization outside of Customer or the corporation of which Customer is a part without the prior written consent of Tektronix, except in connection with the transfer of the equipment within which the programs are encoded or incorporated;

- c. Export or re-export, directly or indirectly, the program, any associated documentation, or the direct product thereof, to any country to which such export or re-export is restricted by law or regulation of the United States or any foreign government having jurisdiction without the prior authorization, if required, of the Office of Export Administration, Department of Commerce, Washington, D.C. and the corresponding agency of such foreign government;
- d. For object-code Programs only, reverse compile or disassemble the Program for any purpose; or
- e. Copy the documentation accompanying the Program.

For Programs designed to reside on a single-machine and support one or more additional machines, either locally or remotely, without permitting the Program to be transferred to an additional machine for local execution, the additional machines shall be considered within the definition of "single machine". For programs permitting the Program to be transferred to an additional machine for local execution, a separate license shall be required for each such machine with which the Program may be used, or each concurrent user authorized under a floating-user license.

Title to the Program and all copies thereof, but not the media on which the Program or copies may reside, shall be and remain with Tektronix or others for whom Tektronix has obtained a respective licensing right.

Customer shall pay when due all property taxes that may now or hereafter be imposed, levied or assessed with respect to the possession or use of the Program or this license and shall file all reports required in connection with such taxes.

Any portion of the Program modified by Customer or merged with another program shall remain subject to these terms and conditions.

If the Program is acquired by or for an agency of the U.S. Government, the Program shall be considered computer software developed at private expense and the license granted herein shall be interpreted as granting Customer restricted rights in the Program and related documentation as defined in the applicable acquisition regulation.

THE PROGRAM MAY NOT BE USED, COPIED, MODIFIED, MERGED, OR TRANSFERRED TO ANOTHER EXCEPT AS EXPRESSLY PERMITTED BY THESE TERMS AND CONDITIONS.

UPON TRANSFER OF ANY COPY, MODIFICATION, OR MERGED PORTION OF THE PROGRAM, THE LICENSE GRANTED HEREIN IS AUTOMATICALLY TERMINATED.

TERM. The license granted herein is effective upon acceptance by Customer, and shall remain in effect until terminated as provided herein. The license may be terminated by Customer at any time upon written notice to Tektronix. The license may be terminated by Tektronix or any third party from whom Tektronix may have obtained a respective licensing right if Customer fails to comply with any term or condition and such failure is not remedied within thirty (30) days after notice hereof from Tektronix or such third party. Upon termination by either party, Customer shall return to Tektronix or destroy, the Program and all associated documentation, together with all copies in any form.

LIMITED WARRANTY. Tektronix warrants that the media on which the Program is furnished and the encoding of the Program on the media will be free from defects in materials and workmanship for a period of three (3) months from the date of shipment. If any such medium or encoding proves defective during the warranty period, Tektronix will provide a replacement in exchange for the defective medium. Except as to the media on which the Program is furnished, the Program is provided "as is" without warranty of any kind, either express or implied. Tektronix does not warrant that the functions contained in the Program will meet Customer's requirements or that the operation of the Program will be uninterrupted or error-free.

In order to obtain service under this warranty, Customer must notify Tektronix of the defect before the expiration of the warranty period. If Tektronix is unable to provide a replacement that is free from defects in materials and workmanship within a reasonable time thereafter, Customer may terminate the license for the Program and return the Program and any associated materials for credit or refund.

THIS WARRANTY IS GIVEN BY TEKTRONIX WITH RESPECT TO THE PROGRAM IN LIEU OF ANY OTHER WARRANTIES, EXPRESS OR IMPLIED. TEKTRONIX AND ITS VENDORS DISCLAIM ANY IMPLIED WARRANTIES OF MERCHANTABILITY OR FITNESS FOR A PARTICULAR PURPOSE. TEKTRONIX' RESPONSIBILITY TO REPLACE DEFECTIVE MEDIA, OR REFUND CUSTOMER'S PAYMENT IS THE SOLE AND EXCLUSIVE REMEDY PROVIDED TO THE CUSTOMER FOR BREACH OF THIS WARRANTY.

LIMITATION OF LIABILITY, IN NO EVENT SHALL TEKTRONIX OR OTHERS FROM WHOM TEKTRONIX HAS OBTAINED A LICENSING RIGHT BE LIABLE FOR ANY INDIRECT, SPECIAL, INCIDENTAL, OR CONSEQUENTIAL DAMAGES ARISING OUT OF OR CONNECTED WITH CUSTOMER'S POSSESSION OR USE OF THE PROGRAM, EVEN IF TEKTRONIX OR SUCH OTHERS HAS ADVANCE NOTICE OF THE POSSIBILITY OF SUCH DAMAGES.

THIRD-PARTY DISCLAIMER. Except as expressly agreed otherwise, third parties from whom Tektronix may have obtained a licensing right do not warrant the program, do not assume any liability with respect to its use, and do not undertake to furnish any support or information relating thereto.

GENERAL. This Agreement contains the entire agreement between the parties with respect to the use, reproduction, and transfer of the Program.

Neither this Agreement nor the license granted herein is assignable or transferable by Customer without the prior written consent of Tektronix.

This Agreement and the license granted herein shall be governed by the laws of the state of Oregon.

All questions regarding this Agreement or the license granted herein should be directed to the nearest Tektronix Sales Office.

Table of Contents

General Safety Summary	ix
Environmental Considerations	xi
Preface	xiii
About This Manual	xiii
Related Manuals	xiii
Getting Started	
Product Description	1-1
Accessories	1-2
Options	1-2
Initial Product Inspection	1-4
Installation	1-4
Warning Message for Fan Failure	1-7
Operating Basics	
Front-Panel Controls	2-1
Rear-Panel Connectors	2-3
About the Frame Reset Signals	2-4
Note for Format Settings	2-5
Reference	
Using the Menu Control Buttons and Menu Displays	3-1
Mainframe Main Menu	3-1
Connecting to a Network	3-15
Connecting the TG700 to your PC(s)	3-15
Setting Ethernet Network Parameters	3-16
Using the General Purpose Interface (GPI)	3-19
Setting the GPI	3-19
Pin Assignments of the 10 BASE-T Connector	3-22
Recalling a Preset	3-23
Outputting an Alarm Signal	3-24
Using TG7 Comm for File Transfers	3-27
PC System Requirements	3-27
Installation Instructions and Ethernet Setup	3-27
Starting and Exiting TG7 Comm	3-31
Elements of the TG7 Comm Window	3-31
Using the TG7 Comm Menus	3-33
TG7 Comm Tutorials	3-35

Using Frame Picture Generator (Option FP Only)	3-39
PC System Requirements	3-39
Installation Instructions	3-39
Starting and Exiting Frame Picture Generator	3-41
Elements of the Frame Picture Generator Window	3-42
Using the Frame Picture Generator Menus	3-44
Frame Picture Generator Tutorials	3-46
Using Logo Generator	3-49
PC System Requirements	3-49
Installation Instructions	3-49
Starting and Exiting Logo Generator	3-51
Elements of the Logo Generator Window	3-52
Using the Logo Generator Menus	3-54
Logo Generator Tutorials	3-57
Using TG7 Setup to Set Parameters	3-59
PC System Requirements	3-59
Installation Instructions and Ethernet Setup	3-59
Starting and Exiting TG7 Setup	3-62
Elements of the TG7 Setup Window	3-63
Using the TG7 Setup Menus	3-64
TG7 Setup Tutorial	3-66
Using the File Copy Tools	3-69
PC System Requirements	3-69
Installation Instructions and Ethernet Setup	3-69
Starting and Exiting the File Copy Tools	3-72
File Copy Tools Tutorials	3-72
Syntax	3-77
Programming Model	3-78
SCPI Commands and Queries	3-80
IEEE 488.2 Common Commands	3-85
Constructed Mnemonics	3-86
Block Arguments	3-86
Special Characters	3-87
Remote Commands	3-89
Common Commands	3-89
DISPLAY Commands	3-91
INSTRUMENT Commands	3-92
MASS MEMORY Commands	3-93
PROGRAM Commands	3-96
SENSE Commands	3-97
STATUS Commands	3-98
SYSTEM Commands	3-101
Sequence Programming	3-103
Writing a Sequence Program	3-103
Running a Sequence	3-103
Tcl Programming Changes	3-104

Appendices

Appendix A: Specifications	A-1
Electrical Characteristics	A-1
Environmental Characteristics	A-2
Mechanical Characteristics	A-2
Certifications and Compliances	A-4
Appendix B: Module Installation	B-1
Preventing Component Damage	B-1
Installing a Module	B-2
Removing a module	B-4
Appendix C: Network Interface Specifications	C-1
Checking Remote Command Operation	C-1
Appendix D: Error Messages and Codes	D-1
Command Errors	D-1
Execution Errors	D-2
Device Specific Errors	D-4
Query Errors	D-5
Device Errors	D-5
Appendix E: Firmware Upgrade	E-1
Equipment Required	E-1
Upgrade Procedures	E-1
Firmware Version Check	E-4
Appendix F: Inspection and Cleaning	F-1
Exterior Inspection	F-1
Exterior Cleaning	F-2

Index

List of Figures

Figure 1-1: Installing the rackmount hardware	1-5
Figure 1-2: Placing the TG700 in the rack	1-6
Figure 2-1: TG700 front panel	2-1
Figure 2-2: TG700 rear panel	2-3
Figure 3-1: Mainframe main menu	3-1
Figure 3-2: PRESET submenu	3-3
Figure 3-3: SEQUENCE submenu	3-5
Figure 3-4: FRAME RESET STATUS submenu	3-6
Figure 3-5: UTILITY submenu	3-7
Figure 3-6: SIGNAL KEY ASSIGN submenu	3-9
Figure 3-7: NETWORK INFORMATION submenu	3-10
Figure 3-8: NETWORK SETUP submenu	3-11
Figure 3-9: DIAGNOSTICS submenu	3-13
Figure 3-10: Pin connections for a 10BASE-T crossover Ethernet cable	3-15
Figure 3-11: NETWORK SETUP submenu	3-16
Figure 3-12: Top cover removal	3-20
Figure 3-13: Location of the connectors J000/J002/J004/J006/J008	3-21
Figure 3-14: Applying the GPI label to the rear panel	3-22
Figure 3-15: Pin assignments of the 10 BASE-T connector for the GPI	3-22
Figure 3-16: ALARM menu	3-24
Figure 3-17: Ethernet dialog box for TG7 Comm	3-30
Figure 3-18: TG7 Comm application window	3-31
Figure 3-19: File name confirmation dialog box	3-36
Figure 3-20: Sequence File dialog box	3-37
Figure 3-21: Frame Picture Generator application window	3-42
Figure 3-22: BUILDING PIC FILES dialog box	3-46
Figure 3-23: Logo Generator application window	3-52
Figure 3-24: Gray Scale Settings dialog box	3-55
Figure 3-25: Miscellaneous Settings dialog box	3-56
Figure 3-26: BMP to LGO File Conversion dialog box	3-58
Figure 3-27: Ethernet dialog box for TG7 Setup	3-62
Figure 3-28: TG7 Setup application window	3-63

Figure 3-29: Rename dialog box	3-65
Figure 3-30: Setup window for DVG7 module	3-66
Figure 3-31: TG7 Backup window	3-73
Figure 3-32: Dialog box shows backup is complete	3-73
Figure 3-33: TG7 Restore window	3-74
Figure 3-34: Dialog box shows restore is complete	3-74
Figure 3-35: TG7 Duplicator window	3-75
Figure 3-36: Dialog box shows file transfer is complete	3-76
Figure 3-37: Example of SCPI subsystem hierarchy tree	3-80
Figure 3-38: Example of abbreviating a command	3-82
Figure 3-39: Example of chaining commands and queries	3-83
Figure 3-40: Example of omitting root and lower-level nodes in a chained message	3-83
Figure A-1: TG700 dimensions	A-3
Figure B-1: TG700 slot numbering	B-2
Figure B-2: Removing the blank panel	B-3
Figure B-3: Installing the module	B-3
Figure B-4: Securing the module	B-4
Figure B-5: Removing the module	B-5
Figure E-1: TG700 Upgrade dialog box	E-2
Figure E-2: Message box appearing after the file transfer is complete	E-2

List of Tables

Table 1-1: Standard and optional accessories	1-2
Table 1-2: Instrument options	1-2
Table 1-3: Power cord options	1-3
Table 1-4: AC line power requirements	1-7
Table 3-1: Jumper settings of the connectors and available feature	3-21
Table 3-2: Combinations of signal levels and the corresponding preset	3-23
Table 3-3: Elements of the TG7 Comm window	3-32
Table 3-4: Toolbar button descriptions	3-32
Table 3-5: TG7 Comm File menu commands	3-33
Table 3-6: TG7 Comm View menu commands	3-34
Table 3-7: TG7 Comm Utility menu commands	3-35
Table 3-8: Elements of the Frame Picture Generator window	3-42
Table 3-9: Toolbar button descriptions	3-43
Table 3-10: Frame Picture Generator File menu commands	3-44
Table 3-11: Frame Picture File Build menu commands	3-44
Table 3-12: Frame Picture Generator Settings menu commands ..	3-45
Table 3-13: Frame Picture Generator Window menu commands ..	3-45
Table 3-14: Elements of the Logo Generator window	3-53
Table 3-15: Toolbar button descriptions	3-53
Table 3-16: Logo Generator File menu commands	3-54
Table 3-17: Logo Generator Build menu commands	3-54
Table 3-18: Logo Generator Settings menu commands	3-54
Table 3-19: Logo Generator Help menu command	3-57
Table 3-20: Elements of the TG7 Setup window	3-63
Table 3-21: TG7 Setup File menu commands	3-64
Table 3-22: TG7 Setup Window menu commands	3-65
Table 3-23: Parameter types used in syntax descriptions	3-81
Table 3-24: BNF symbols and meanings	3-85
Table A-1: Electrical characteristics	A-1
Table A-2: Environmental characteristics	A-2
Table A-3: Mechanical characteristics	A-2
Table A-4: Certifications and compliances	A-4
Table D-1: Command errors	D-1

Table D-2: Execution errors	D-2
Table D-3: Device specific errors	D-4
Table D-4: Query errors	D-5
Table D-5: Device errors	D-5
Table G-1: External inspection check list	F-1

General Safety Summary

Review the following safety precautions to avoid injury and prevent damage to this product or any products connected to it. To avoid potential hazards, use this product only as specified.

Only qualified personnel should perform service procedures.

To Avoid Fire or Personal Injury

Use Proper Power Cord. Use only the power cord specified for this product and certified for the country of use.

Ground the Product. This product is grounded through the grounding conductor of the power cord. To avoid electric shock, the grounding conductor must be connected to earth ground. Before making connections to the input or output terminals of the product, ensure that the product is properly grounded.

Observe All Terminal Ratings. To avoid fire or shock hazard, observe all ratings and markings on the product. Consult the product manual for further ratings information before making connections to the product.

Do Not Operate Without Covers. Do not operate this product with covers or panels removed.

Avoid Exposed Circuitry. Do not touch exposed connections and components when power is present.

Do Not Operate With Suspected Failures. If you suspect there is damage to this product, have it inspected by qualified service personnel.

Do Not Operate in Wet/Damp Conditions.

Do Not Operate in an Explosive Atmosphere.

Keep Product Surfaces Clean and Dry.

Provide Proper Ventilation. Refer to the manual's installation instructions for details on installing the product so it has proper ventilation.

No Power Switch. Power supply cord is considered the disconnecting device, disconnect the main power by means of the power cord.

Symbols and Terms

Terms in this Manual. These terms may appear in this manual:



WARNING. *Warning statements identify conditions or practices that could result in injury or loss of life.*



CAUTION. *Caution statements identify conditions or practices that could result in damage to this product or other property.*

Terms on the Product. These terms may appear on the product:

DANGER indicates an injury hazard immediately accessible as you read the marking.

WARNING indicates an injury hazard not immediately accessible as you read the marking.

CAUTION indicates a hazard to property including the product.

Symbols on the Product. The following symbols may appear on the product:



Environmental Considerations

This section provides information about the environmental impact of the product.

Product End-of-Life Handling

Observe the following guidelines when recycling an instrument or component:

Equipment Recycling. Production of this equipment required the extraction and use of natural resources. The equipment may contain substances that could be harmful to the environment or human health if improperly handled at the product's end of life. In order to avoid release of such substances into the environment and to reduce the use of natural resources, we encourage you to recycle this product in an appropriate system that will ensure that most of the materials are reused or recycled appropriately.



The symbol shown to the left indicates that this product complies with the European Union's requirements according to Directive 2002/96/EC on waste electrical and electronic equipment (WEEE). For information about recycling options, check the Support/Service section of the Tektronix Web site (www.tektronix.com).

Restriction of Hazardous Substances

This product has been classified as Monitoring and Control equipment, and is outside the scope of the 2002/95/EC RoHS Directive. This product is known to contain lead, cadmium, mercury, and hexavalent chromium.

Preface

This manual describes the capabilities of the TG700 TV Signal Generator Platform. This manual describes features and specifications that are common to all generator modules. These include system configuration and the common control interface.

Operation of the generator and special function modules is described in the module User manuals.

About This Manual

This manual is composed of the following sections:

- *Getting Started* shows you how to configure and install your TG700 and provides an Incoming Inspection procedure. Also describes the mainframe options.
- *Operating Basics* provides an overview of the front panel controls and rear panel connections.
- *Reference* provides instructions for controlling all the instrument functions using the menu and connecting to a Ethernet network, and presents descriptions of all programming commands and the syntax used in command descriptions. This section also provides instructions for operating the many application software supplied with the instrument.
- *Appendices* provides additional information including the Specifications and instructions for module installation.

Related Manuals

The following documents are also available for the TG700:

- The *TG700 TV Signal Generator Platform Service Manual* (Tektronix part number 071-A800-XX) describes how to service the TG700 mainframe to the module level (circuit boards, fuses, etc.) and provides general information about servicing generator modules. Specific service information for a module is located in its Service manual. Service manuals are optional and must be ordered separately.
- The *TG700 TV Signal Generator Platform Module Installation Instructions* (Tektronix part number 070-A824-XX) describes how to install and remove the modules, and how to upgrade the firmware of the mainframe.



Getting Started

Getting Started

This section contains the following information:

- Product description
- List of standard and optional accessories
- List of instrument options
- Initial product inspection procedure
- Installation instructions

Product Description

The TG700 TV Signal Generator Platform is a multiformat TV signal generator platform supporting both of analog and digital video standards. The TG700 consists of a mainframe and up to four plug-in modules. The modules are either signal generators or they provide special functions, such as genlock capability.

Key Features

The TG700 and the available modules provide the following features:

- Simultaneous generation of HDTV/SDTV multi format synchronized signal and test signal
- Modular architecture with up to four generators or special function modules
- Analog genlock function dealing with NTSC or PAL black burst signal, HDTV trilevel sync signal, and CW signals (AGL7).
- Independent setting of amplitudes, frequencies, and audio clicks of 16 channel embedded audio signal (DVG7 and HDVG7)
- Circle, logo, and text overlays on test signals (DVG7 and HDVG7)
- Moving picture generation function by scrolling the active area of the signal (DVG7 and HDVG7)
- Reference generator performance level
- Ethernet interface for remote control and downloading various files such as signal files, logo files, and preset files

A signal library and various application software are included in the attachment CD-ROM to execute the following operations:

- Upload and download files such as signal files, logo files, and preset files
- Download the signals from the signal library to the TG700
- Create a logo (logo file) to be inserted into the test signal
- Create a frame picture file using the generation of a picture or test pattern

Accessories

Table 1-1 lists the standard and optional accessories provided with the TG700 mainframe.

Table 1-1: Standard and optional accessories

Accessory	Std.	Opt.	Tektronix part number
TG700 TV Signal Generator Platform User Manual	●		070-A799-XX
Power cord 125 V/6A	●		161-0216-00
TG700 Signal Generator Platform Software Library CD-ROM	●		062-A249-XX
Hardware for rackmounting	●		351-0859-00
TG700 TV Signal Generator Platform Service Manual		●	070-A800-XX
Blank panel		●	614-A021-00

Options

Table 1-2 lists the instrument options that can be ordered with the TG700 mainframe. Table NO TAG lists the available power cord options.

Table 1-2: Instrument options

Option number	Description
D1 (Calibration Test Data Report)	When you order Option D1, a report with the calibration test data for the instrument will be provided with your TG700 mainframe.
FP (Add Frame Picture feature)	When you order Option FP, frame picture feature will be provided with your TG700 mainframe and pictures and test patterns can be generated.

Table 1-3: Power cord options

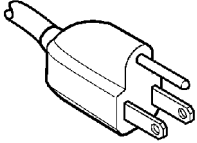
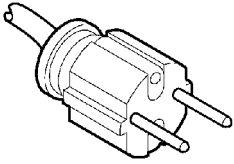
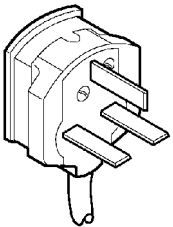
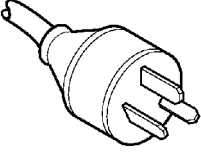
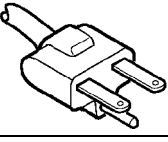
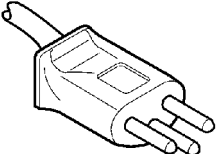
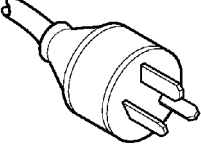
Plug configuration	Normal usage	Option number
	North America 115 V	Standard (A0)
	United Euro 220 V	A1
	United Kingdom 240 V	A2
	Australia 240 V	A3
	North America 250 V	A4
	Switzerland 240 V	A5
	China 240 V	A10

Initial Product Inspection

Perform the following product inspection procedure when you initially receive your instrument:

1. Inspect the TG700 shipping carton for external damage, which indicates possible damage to the instrument.
2. Remove the TG700 from the shipping carton, and then check that the instrument has not been damaged in transit. Prior to shipment the instrument is thoroughly inspected for mechanical defects. The exterior should not have any scratches or impact marks.

NOTE. *Save the shipping carton and packaging materials for instrument repackaging in case shipment becomes necessary.*

3. Verify that the shipping carton contains the basic instrument, the standard accessories listed in Table 1-1, and any optional accessories that you ordered.

Contact your local Tektronix Field Office or representative if there is a problem with your instrument or if your shipment is incomplete.

Installation

This section describes the installation information for the TG700 mainframe.

Hardware Installation

The TG700 is shipped with the optional generator modules that you ordered configured and installed. Refer to *Appendix B: Module Installation* in this manual if you want to add any modules afterwards. Refer to *Rackmount Installation* on page 1-4 for rackmounting instructions.

Rackmount Installation

The TG700 is configured at shipment for use in an equipment rack. Use the information in Figure 1-1 to connect the rackmount hardware to the rack.

Figure 1-2 shows how to install the TG700 into the rack. Carefully start the rack pieces attached to the TG700 into the pieces attached to the rack. Support the TG700 until the stop latches click into place on both sides. The installation is not secure until this latching occurs. Continue to slide the TG700 completely into the rack.

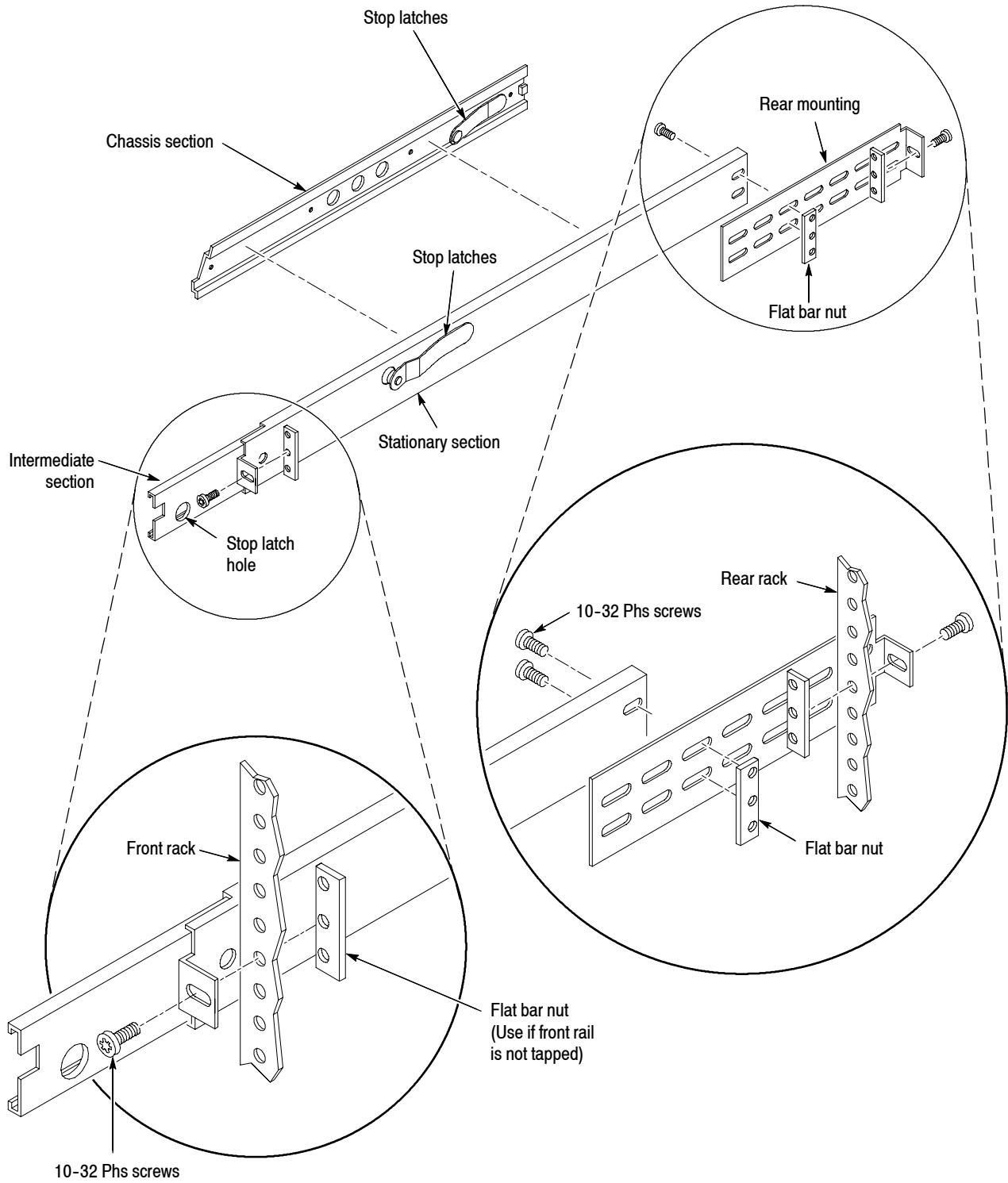

Figure 1-1: Installing the rackmount hardware

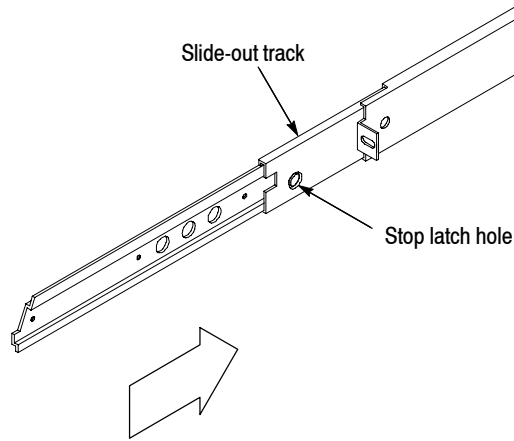

Figure 1-2: Placing the TG700 in the rack

To remove the TG700 from the rack mount, slide it out until it stops at the catches. Support the TG700 while you press in on the stop latch buttons on each side. This action will free the TG700 to slide completely out of the rack. Provide support while you slide the mainframe out of the rack.

Environmental Operating Requirements



Verify that the location of your installation has the proper operating environment.

CAUTION. *Damage to the instrument can occur if this instrument is powered on at temperatures outside the specified temperature range.*

The TG700 operates correctly in ambient temperatures from 0 °C to +50 °C and in relative humidity from 20% to 80%. For complete operating environment information, refer to *Appendix A: Specifications*.

Leave space for cooling by ensuring standard side clearance for rack mounting or 2 inches (5.1 cm) of side clearance for counter top use. Also, ensure sufficient rear clearance (approximately 2 inches) so that cables are not damaged by sharp bends.

Connecting Power

The TG700 operates from a single-phase power source with the neutral conductor at or near earth ground. The line conductor is fused for over-current protection. A protective ground connection through the grounding conductor in the power cord is essential for safe operation.



CAUTION. *The instrument does not have a power switch. When you connect the power cable to the AC line connector, the instrument powers on.*

AC Power Requirements. Check that your location provides the proper electrical power requirements as listed in Table 1-4.

Table 1-4: AC line power requirements

Parameter	Description
Line Voltage Range	85 V - 250 V
Line frequency	48 Hz - 63 Hz
Maximum power	100 W

Connecting Cable. Connect the power cable to the instrument first, and then connect it to the AC power source. Note that connecting the power cable causes the instrument to power on.

After connecting the power, make sure that the fan on the rear panel is working. If the fan is not working, turn off the power by disconnecting the power cable from the AC power source and contact your local Tektronix Field Office or representative.

Warning Message for Fan Failure



CAUTION. *If the fan on the rear panel stops working, disconnect the power cable from the AC power source. Internal components could be damaged.*

The TG700 displays the following warning message if the fan on the rear panel stop working:

* FAN FAULT ALARM *
* Main Cooling Fan Serious Problem *

If this warning message appears, disconnect the power cable from the AC voltage line and contact your local Tektronix Field Office or representative.

While the message appears, the front-panel buttons are disabled. However, you can operate the buttons temporarily by pressing the FRONT PANEL ENABLE button on the front panel until the indicator next to the button lights. In this case, the warning message reappears and the front-panel buttons are disabled when five minutes have passed since the last time operation.



Operating Basics

Operating Basics

This section introduces you to the basics of operating the TG700. Common module functions are discussed here, while module specific functions are discussed in the module User manuals. This section contains the following topics:

- Front-panel controls
- Rear-panel connectors
- About the frame reset signals
- Note for format settings

Front-Panel Controls

Figure 2-1 shows the locations of the front-panel controls. A brief discussion of each feature follows the illustration.

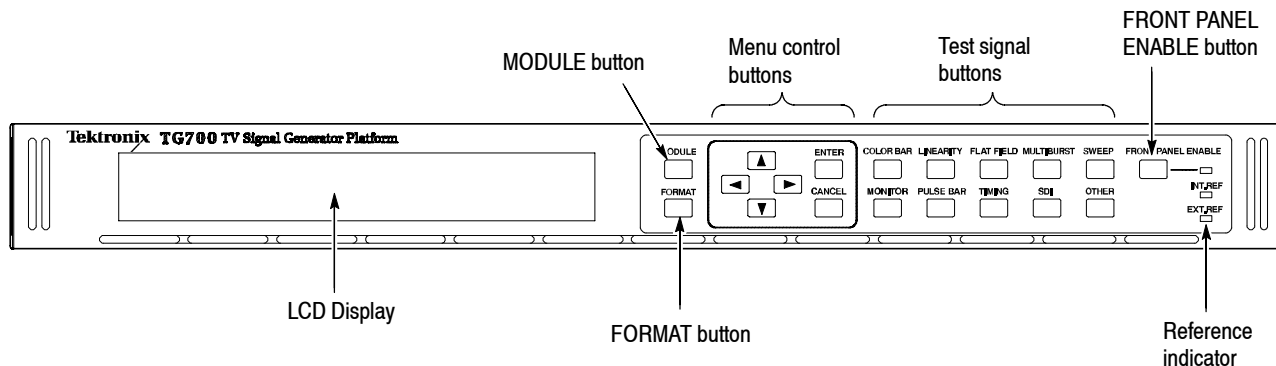

Figure 2-1: TG700 front panel

LCD Display

The LCD display is a two-line, 40-character-per-line display. Almost all menus have two lines of text, where the first line shows the current position in the current menu, and the second line shows the current selection (if there is not a submenu). If nothing is on the second line, press the ENTER button to access the corresponding submenu.

You can adjust the contrast of the LCD display using the UTILITY submenu. Refer to *UTILITY Submenu* on page 3-7 for detailed information about the submenu.

MODULE Button Use the MODULE button to select the mainframe or installed module to control. Repeatedly pressing this button scrolls through the main menu, which shows the mainframe and the installed modules. Select the one you want to control.

FORMAT Button When the ATG7, AVG7, AWVG7, DVG7, HDLG7, or HDVG7 module is selected (active), use the FORMAT button to change the video format for the output signal. Pressing this button displays the menu to allow you to select a format for the active module.

Menu Control Buttons Use these buttons to control the menu display. Refer to *Using the Menu Control Buttons and Menu Display* on page 3-1 for detailed information on controlling menus.

Arrow (◀, ▶, ▲, and ▼) Buttons. Use these arrow buttons to scroll through the available menu items.

ENTER button. Use the ENTER button to enable the selected menu item.

CANCEL Button. Use the CANCEL button to disable the selected menu item and return to the previous menu item.

Test Signal Buttons Use these buttons to select the output test signals. Each of these 10 buttons represents a signal set, or group of the same type of test signals. You scroll through the test signals in a signal set by repeatedly pressing the test signal button.

You can change the signal assignment using the SIGNAL KEY ASSIGN submenu. Refer to *SIGNAL KEY ASSIGN Submenu* on page 3-9 for detailed information about assigning signal sets to the test signal buttons.

FRONT PANEL ENABLE button Use this button to enable or disable the front-panel buttons. When pressing this button for about one second while the front-panel buttons are enabled, all of the front-panel buttons are disabled. If you have selected a timeout period in the FRONT PANEL DISABLE item in the UTILITY submenu, and that period passes without a button push, all of the front-panel buttons are also disabled.

Press and hold this button for about three second to enable the front-panel buttons. The timeout counter is restarted (if the timeout period is already set) and the indicator next to the button lights to show that the front-panel is enabled.

Refer to *UTILITY Submenu* on page 3-7 for more information about the settings the period until the front panel times out.

Reference Indicators

The reference indicators indicate whether the TG700 is locked externally or internally.

INT.REF. This indicator lights when the TG700 is using its internal reference oscillator.

EXT.REF. This indicator lights when the TG700 is locked to an external reference signal. If this indicator is blinking, the TG700 uses the external reference signal but is unable to lock to the signal.

Rear-Panel Connectors

Figure 2-2 shows the locations of the TG700 rear-panel connectors. A brief discussion of each feature follows the illustration.

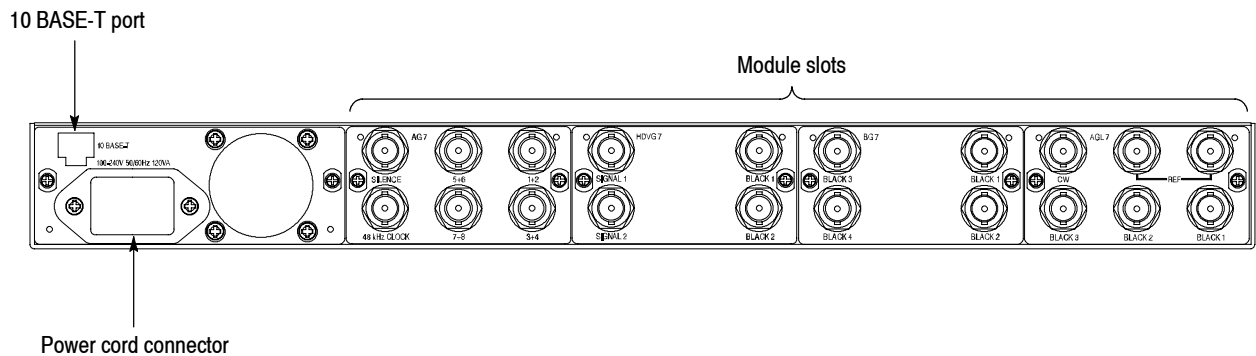

Figure 2-2: TG700 rear panel

Power Connector

The TG700 is designed to operate from a single-phase power source with the neutral conductor at or near earth ground. Only the line conductor is fused for over-current protection. A protective ground connection through the grounding conductor in the power cord is essential for safe operation.



WARNING. To avoid dangerous electrical shock, do not connect power to the TG700 when the top cover is off. Dangerous potentials are present on the Power circuit board.

The TG700 operates from an AC line frequency of 48 to 63 Hz, over the range of 85 to 250 VAC, without the need for configuration. Refer to *Appendix A: Specifications* for additional information on power and environmental requirements.

10 BASE-T Port Use this port to connect to your local Ethernet network. You can control the TG700 and all installed modules remotely through the port. Also, you can upload and download various files such as signal files, logo files, and preset files through the port.

Module Slots Use these slots to install the modules. You can install up to four modules. Refer to *Appendix B : Module Installation* for installation procedures for the modules.

About the Frame Reset Signals

The TG700 uses the following three frame reset signals to output different video formats simultaneously:

- **Frame reset signal 1 (FRAME RESET 1)**

This frame reset signal supports the 1/1.001 system signal, and is used by the following video formats:

NTSC	1080 23.98sF
525-270	1080 29.97p
525-143	1080 59.94i
1035 59.94i	720 59.94p
1080 23.98p	

These signals are synchronized with each other.

- **Frame reset signal 2 (FRAME RESET 2)**

This frame reset signal supports the integer system signal, and is used by the following video formats:

PAL	1080 30p
625-270	1080 50i
1035 60i	1080 60i
1080 25p	720 60p

These signals are synchronized with each other.

- **Frame reset signal 3 (FRAME RESET 3)**

When any of the above signal uses the frame reset signal 2, the following video formats use the frame reset signal 3:

1080 24p
1080 24sF

The frequency of frame reset signal 3 is always an integral multiple of that of frame reset signal 2. Frame reset signal 3 is synchronized with frame reset signal 2. Frame reset signal 1 is not synchronized with frame reset signals 2 or 3.

You can see which of the three frame reset signals are used by each output of each module by using the FRAME RESET STATUS submenu. Refer to *FRAME RESET STATUS Submenu* on page 3-6 for detailed information.

Note for Format Settings

The TG700 displays messages to ask whether you want to disable the clock currently used if there is a conflict of signal format settings between two (or more) outputs for the clock assignment.

These messages are displayed under the following conditions:

- For the DVG7 Option BK, when you output 525-143 format signals and 525-270 (or 625-270) format signals simultaneously.

For example, if you set the signal format for the BLACK outputs to 525-270 when the signal format for the SIGNAL outputs are set to 525-143, the following message appears:

```

*   DVG7 Clock Select, Disable 270 MHz?   *
*   Yes : ENTER / No : CANCEL              *
```

This message asks if you want to disable the 270 MHz clock currently in use.

In this case, press the **CANCEL** button to cancel the new format setting or press the **ENTER** button to enable the setting and then re-set the signal format for the other outputs.

- For the HDVG7 Option BK, when you output serial digital signals and serial digital black signals using the 74.25 MHz clock and 74.25/1.001 MHz clock simultaneously; or for the combination of the AGL7, AWVG7, BG7, and HDVG7, when you output serial digital signals and a HDTV trilevel sync signal, or HDTV trilevel sync signals using the 74.25 MHz clock and 74.25/1.001 MHz clock simultaneously.

For example, if you set the HDTV trilevel sync signal format for the BLACK 4 output of the BG7 to 1080 59.94i when the HDTV trilevel sync signal format for the BLACK 3 output of the AGL7 is set to 1080 50i, the following message appears:

* HD Clock Select, Disable 74.25 MHz? *
* Yes : ENTER / No : CANCEL *

This message asks if you want to disable the 74.25 MHz clock currently in use.

In this case, press the **CANCEL** button to cancel the new format setting, or press the **ENTER** button to enable the setting and then reset the signal format for the other outputs.



Reference

Using the Menu Control Buttons and Menu Displays

This section describes how to control all of the instrument functions using the front-panel control buttons and menus.

Mainframe Main Menu

When you power on the TG700 and the initializing process for all of the installed module is completed, the top menu item of the mainframe main menu appears on the LCD display. Press the up (▲) or down (▼) arrow button to scroll through the available menu selections in the main menu.

The mainframe main menu allows you to access submenus to set the various system settings. Figure 3-1 shows the mainframe main menu.

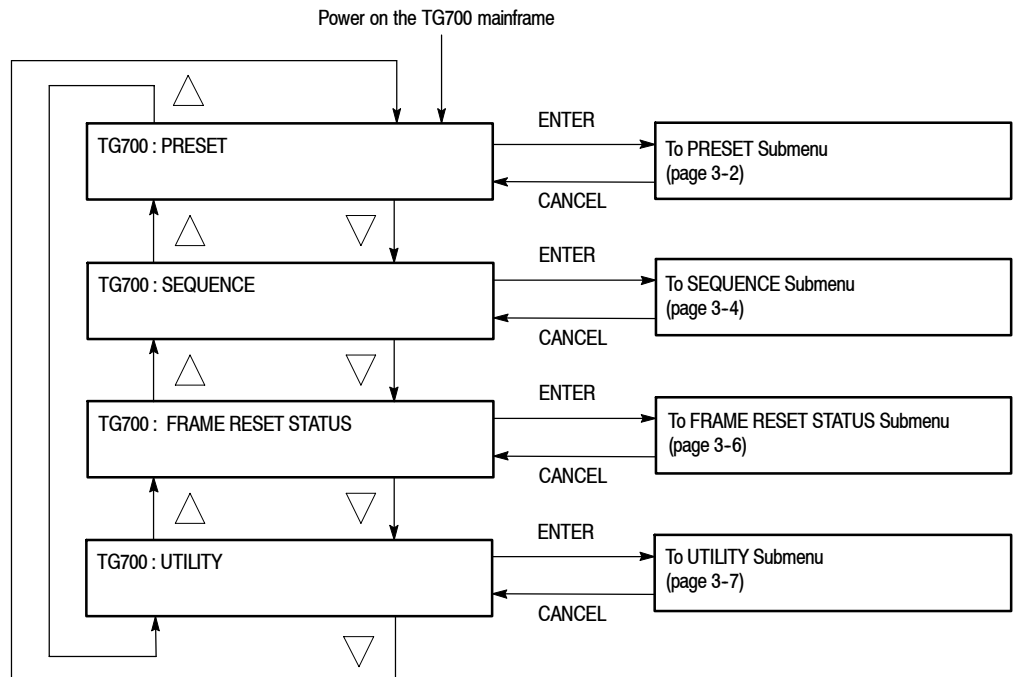

Figure 3-1: Mainframe main menu

PRESET. Recalls instrument settings saved as a preset, or saves the current instrument settings as a preset. When you select this menu item and then press the ENTER button, you access the PRESET submenu. Refer to *PRESET Submenu* on this page for detailed information.

SEQUENCE. Selects and executes a sequence program loaded into the TG700. Select this menu item and press the ENTER button, to access the SEQUENCE submenu. Refer to *SEQUENCE Submenu* on page 3-4 for detailed information.

FRAME RESET STATUS. Displays the status of the frame reset signals. Select this menu item and press the ENTER button to access the FRAME RESET STATUS submenu. Refer to *FRAME RESET STATUS Submenu* on page 3-6 for detailed information.

Also, refer to *About the Frame Reset Signals* on page 2-4 for detailed information about the frame reset signals.

UTILITY. Sets the system related settings such as network parameters and signal sets assignment to the front-panel test signal buttons. Select this menu item and press the ENTER button, to access the UTILITY submenu. Refer to *UTILITY Submenu* on page 3-7 for detailed information.

PRESET Submenu

This menu allows you to recall instrument settings saved as a preset or save the current instrument settings to a preset. Use the up (▲) or down (▼) arrow button to scroll through the menu items. Figure 3-2 shows the PRESET submenu.

The following three presets are named at the factory and can be used for your own application:

- **Power On Default:** When you save instrument settings in the preset, the instrument settings can be loaded into the TG700 automatically at power on. If one of the seven presets is selected in the GPI (General Purpose Interface), the preset takes precedence over the Power On Default. You cannot assign the preset name with the other preset.

NOTE. *If you want to save network parameters to a preset, use the Power On Default preset.*

- **User Default:** The preset for saving the user specified default settings. If you save new instrument settings in this preset, a confirmation message appears to prevent overwriting.

- Factory Default:** In this preset, the factory default settings are saved. Use this preset to reset the mainframe and all of the installed modules to the factory default settings. The following settings are not affected by the factory default: LCD contrast, front panel timeout, and network parameters.

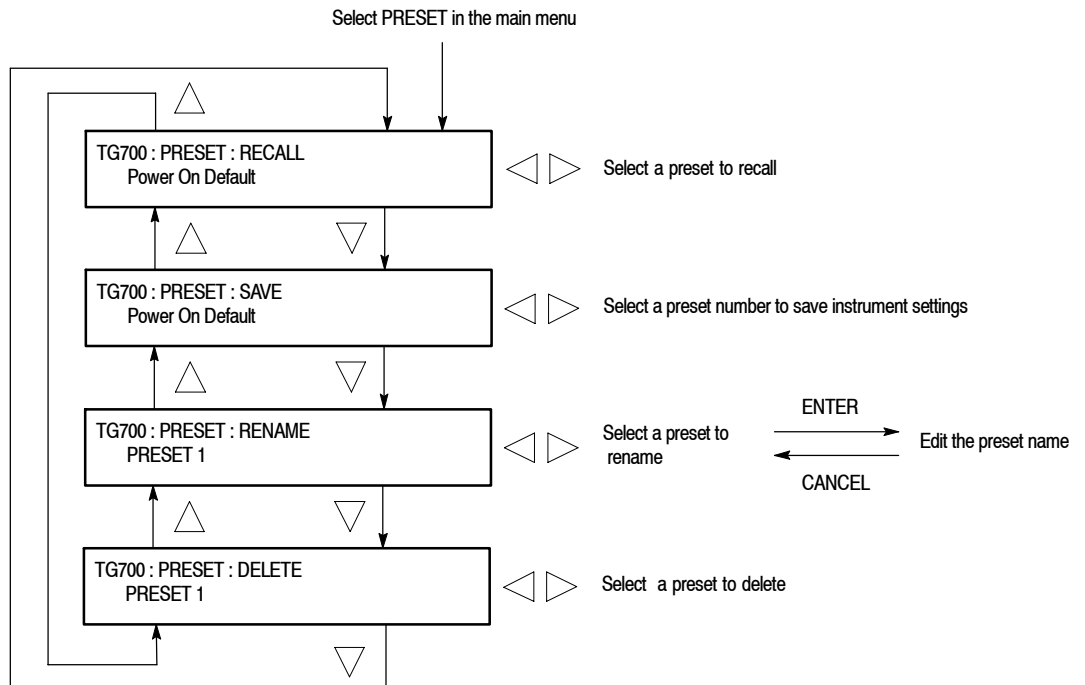

Figure 3-2: PRESET submenu

RECALL. Recalls instrument settings saved as a preset. Use the left (◀) or right (▶) arrow button to select a different preset, and then press the ENTER button to implement the selection.

While the preset is loading into the instrument, the message “Now Loading ...” appears on the display. When the loading is complete, the message “Done (Press CANCEL)” appears. Press the CANCEL button.

SAVE. Saves the current instrument settings to one of the fourteen presets. Use the left (◀) or right (▶) arrow button to select the the destination preset, and then press the ENTER button to implement the selection.

RENAME. Renames the specified preset name. Perform the following steps to rename a preset name:

1. Use the left (◀) or right (▶) arrow button to select the preset you want to rename.
2. Press the **ENTER** button twice to begin editing the preset name. The underscore character (_) appears under the first letter of the preset name.
3. Use the left (◀) or right (▶) arrow button to move the underscore character to the letter you want to modify.
4. Use the up (▲) or down (▼) arrow button to select the new character.

The available characters include the full alphabet, numerals from 0 to 9, and many standard ASCII symbols. The text strings may contain up to 32 characters.

5. Enter all of the desired characters then press **ENTER** button.
6. Press the **CANCEL** button twice to exit the PRESET submenu. This returns to the top of the mainframe main menu.
7. Press the **ENTER** button to reenter the PRESET submenu.
8. Use the up (▲) or down (▼) arrow button to select the SAVE menu item.
9. Use the left (◀) or right (▶) arrow button to select the preset name edited in step 4.
10. Press **ENTER** button to save the preset with the new name.

DELETE. Deletes the specified preset. Use the left (◀) or right (▶) arrow button to select the preset you want to delete, and then press the **ENTER** button to implement the selection. You cannot delete the following presets: Power on Default, User Default, and Factory Default.

SEQUENCE Submenu

This menu allows you to select and run a sequence that is already loaded into the TG700. A sequence is a series of generator settings defined using the Tcl language and SCPI commands. The TG700 loads a sequence and runs the command and settings in the order dictated by the sequences file. Figure 3-3 shows the SEQUENCE submenu.

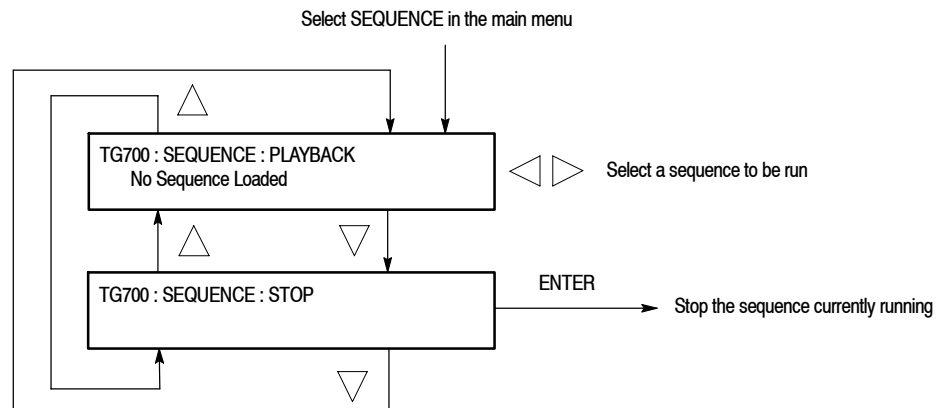

Figure 3-3: SEQUENCE submenu

PLAYBACK. Selects and runs a sequence. Use the left (◀) or right (▶) arrow button to select the sequence you want to run, and then press the ENTER button to run the sequence.

If no sequence is loaded into the instrument, the message “No Sequence Found” is displayed on the second line.

STOP. Stops the sequence currently running. When you select the menu item and then press the ENTER button, the sequence is stopped.

Refer to *Sequence Programming* on page 3-103 for detailed information about the sequence.

FRAME RESET STATUS Submenu

This menu allows you to display which of the three frame reset signals is used by the output of the installed modules. Use the up (▲) or down (▼) arrow button to scroll through the menu items. Figure 3-4 shows the FRAME RESET STATUS submenu.

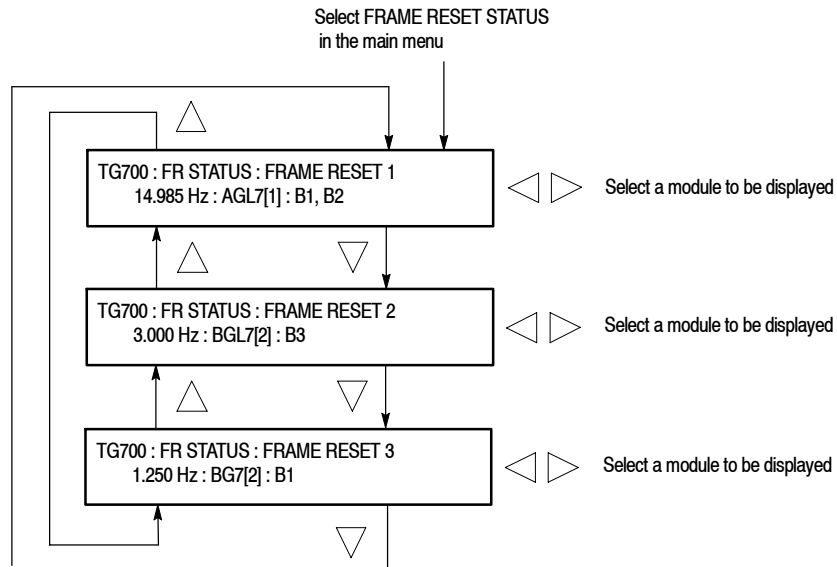

Figure 3-4: FRAME RESET STATUS submenu

FRAME RESET 1. Display the module(s) and output(s) using the frame reset signal 1. If two or more modules use the frame reset signal, use the left (◀) or right (▶) arrow button to change the modules to be displayed.

FRAME RESET 2. Display the module(s) and output(s) using the frame reset signal 2. If two or more modules use the frame reset signal, use the left (◀) or right (▶) arrow button to change the modules to be displayed.

FRAME RESET 3. Display the module(s) and output(s) using the frame reset signal 3. If two or more modules use the frame reset signal, use the left (◀) or right (▶) arrow button to change the modules to be displayed.

The character after the module name represents the output connector of the module. For example, **B1** represents **BLACK 1** connector.

UTILITY Submenu

This menu allows you to set the system related settings such as the contrast of the LCD display and the network parameters. Use the up (▲) or down (▼) arrow button to scroll through the menu items. Figure 3-5 shows the UTILITY submenu.

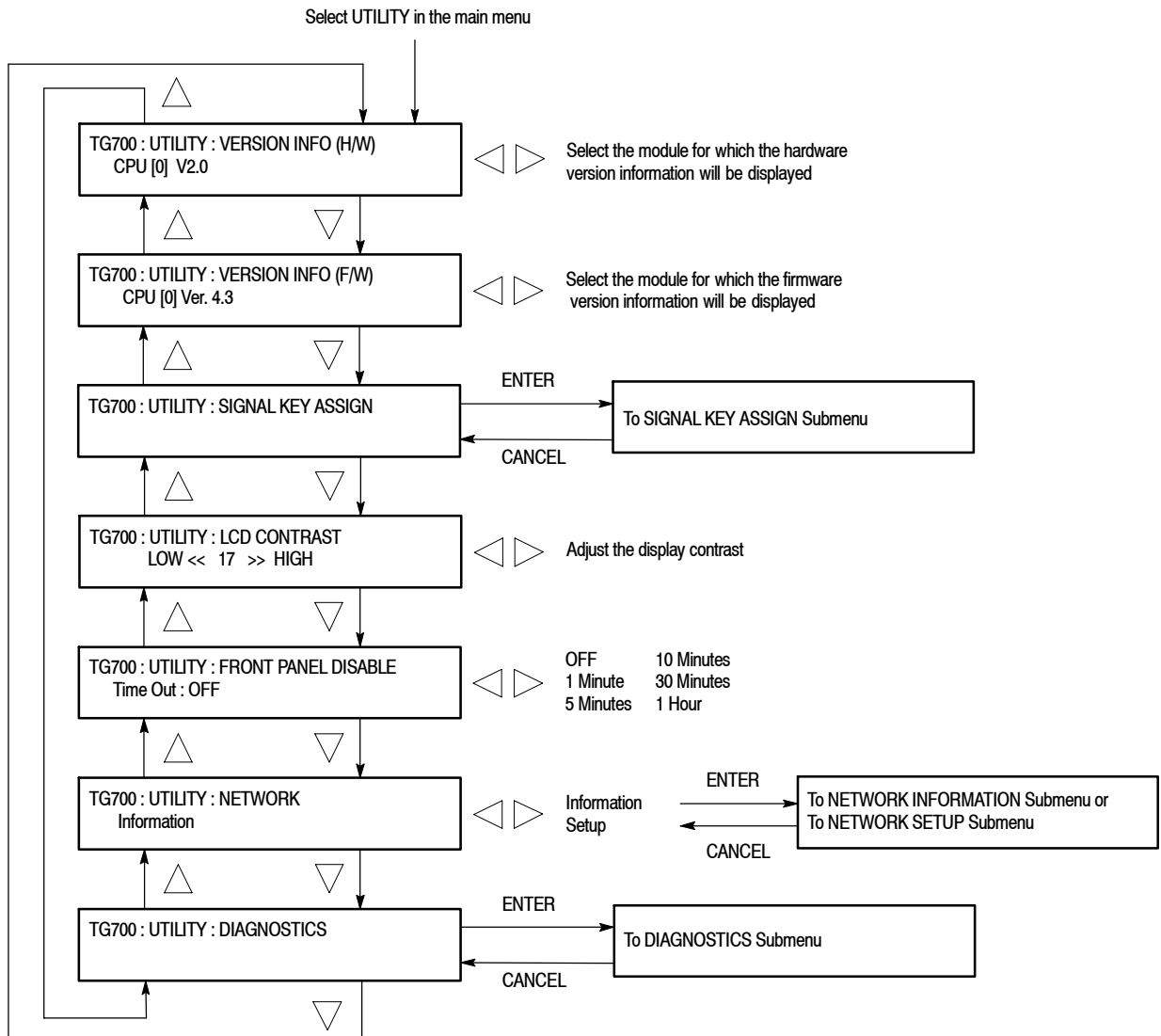

Figure 3-5: UTILITY submenu

VERSION INFO (H/W). Displays the hardware version of the mainframe and the modules currently installed. Use the left (◀) or right (▶) arrow button to select the module you want to display the information.

VERSION INFO (F/W). Displays the firmware version number for the mainframe and the modules currently installed. Use the left (◀) or right (▶) arrow button to select the module you want to display the information.

SIGNAL KEY ASSIGN. Assigns signal sets to the front-panel test signal buttons, and assigns a frame picture file created by the Frame picture Generator application supplied with the TG700 to the OTHER test signal button (Option FP only). When you select this menu item and press the ENTER button, you will access the SIGNAL KEY ASSIGN submenu. Refer to *SIGNAL KEY ASSIGN Submenu* on page 3-9 for detailed information.

LCD CONTRAST. Adjusts the contrast of the LCD display. You can lower the contrast by pressing the left (◀) arrow button and raise the contrast by pressing the right (▶) arrow button.

FRONT PANEL DISABLE. Sets the timeout period until the front-panel buttons are disabled. Use the left (◀) or right (▶) arrow button to make the selection. The choices are **OFF, 1 Minute, 5 Minutes, 10 Minutes, 30 Minutes, and 1 Hour.** Press the ENTER button to enable the selection.

When you select any of these timeout periods (except OFF), the front-panel buttons are disabled when that time passes without a button push. When this happens, press and hold the FRONT PANEL ENABLE button for about 1 second to restart the timeout counter and enable the front-panel buttons

The indicator next to the FRONT PANEL ENABLE button lights when the front-panel buttons are enabled.

NETWORK. Displays the network parameters currently set or sets the network parameters for the 10BASE-T port on the TG700. Use the left (◀) or right (▶) arrow button to toggle between **Information** and **Setup**. When you select Information and press the ENTER button, you will access the NETWORK INFORMATION submenu. When you select Setup and press the ENTER button, you will access the NETWORK SETUP submenu.

Refer to *NETWORK INFORMATION Submenu* on page 3-10 for detailed information about the submenu. Also, refer to *NETWORK SETUP Submenu* on page 3-11 for detailed information about the submenu.

DIAGNOSTICS. Executes the diagnostic routines for the mainframe and installed modules. When you select the menu item and then press the ENTER button, you access the DIAGNOSTICS submenu. Refer to *DIAGNOSTICS Submenu* on page 3-13 for detailed information.

SIGNAL KEY ASSIGN Submenu

This menu allows you to assign signal sets to a specific test signal button on the front panel. You can also assign a frame picture file created by the Frame Picture Generator application supplied with the TG700 to the OTHER test signal button. Figure 3-6 shows the SIGNAL KEY ASSIGN submenu.

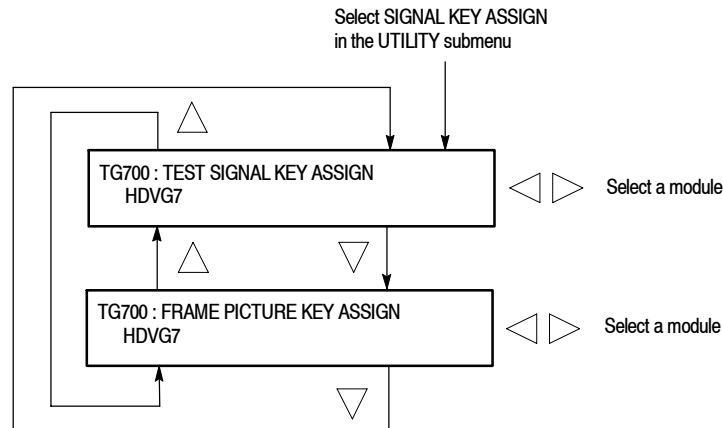

Figure 3-6: SIGNAL KEY ASSIGN submenu

TEST SIGNAL KEY ASSIGN. Assigns signal sets to a specific test signal button on the front panel.

For each test signal button, the signal sets corresponding to the button name are already assigned at the factory. For example, when you press the **COLOR BAR** test signal button, the three types of color bars signal (100% Color Bars, 75% Color Bars, and SMPTE Color Bars) are output.

Perform the following steps to assign signal sets to a specific test signal button.

1. Use the left (◀) or right (▶) arrow button to select the module you want to assign signal sets to, and then press the **ENTER** button. This will display the following submenu to assign signal sets.

```
TG700 : HDVG7 : COLOR BAR KEY
COLOR BAR
```

The first line shows the test signal button name, and second line shows the signal set name.

2. Use the up (▲) or down (▼) arrow button to select the test signal button (for example **COLOR BAR KEY**) to be assign signal sets.
3. Use the left (◀) or right (▶) arrow button to select the signal sets (for example **COLOR BAR**) you want to assign.
4. Press the **ENTER** button to implement the assignment.

5. Repeat Steps 2 to 4 until all signal set assignments are completed.

FRAME PICTURE KEY ASSIGN. Assigns frame picture files downloaded to the TG700 to the OTHER test signal button. This operation is required to output the frame picture files as a picture (natural picture or test pattern).

NOTE. When you download a frame picture file created by the Frame Picture Generator application and output it a picture, Option FP must be installed.

Perform the following steps to assign a frame picture file to the OTHER test signal button:

1. Use the left (◀) or right (▶) arrow button to select the module you want to assign a frame picture file, and press the **ENTER** button. This will display the following submenu.

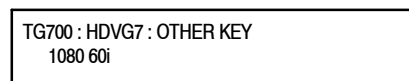

The second line shows the folder name created when the frame picture file was downloaded to the TG700.

2. Use the left (◀) or right (▶) arrow button to select the folder in which the frame picture file is saved.
3. Press the **ENTER** button to implement the assignment.

Refer to *Using Frame Picture Generator* on page 3-39 for detailed information about how to create a frame picture file. Also, refer to *Using TG7 Comm for File Transfers* on page 3-27 for detailed information about how to download a frame picture file from the PC to the TG700.

NETWORK INFORMATION Submenu

This menu allows you to display all of the network parameters currently set. Figure 3-7 shows NETWORK INFORMATION submenu.

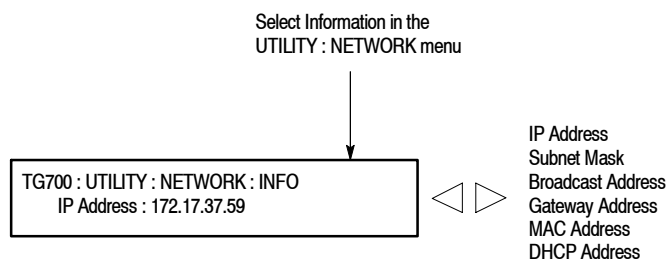

Figure 3-7: NETWORK INFORMATION submenu

Use the left (◀) or right (▶) arrow button to select the menu items and display the address value. The following selections are available: **IP Address**, **Subnet Mask**, **Broadcast Address**, **Gateway Address**, **MAC Address**, and **DHCP Server**.

NETWORK SETUP Submenu

This menu allows you to set network parameters for the 10 BASE-T port on the TG700. These parameters will be used when you connect the TG700 to a remote computer (PC) so that you can control the TG700 remotely using the PC and transfer various files between the TG700 and the PC. Use the up (▲) or down (▼) arrow button to scroll through the menu items. Figure 3-8 shows the NETWORK SETUP submenu.

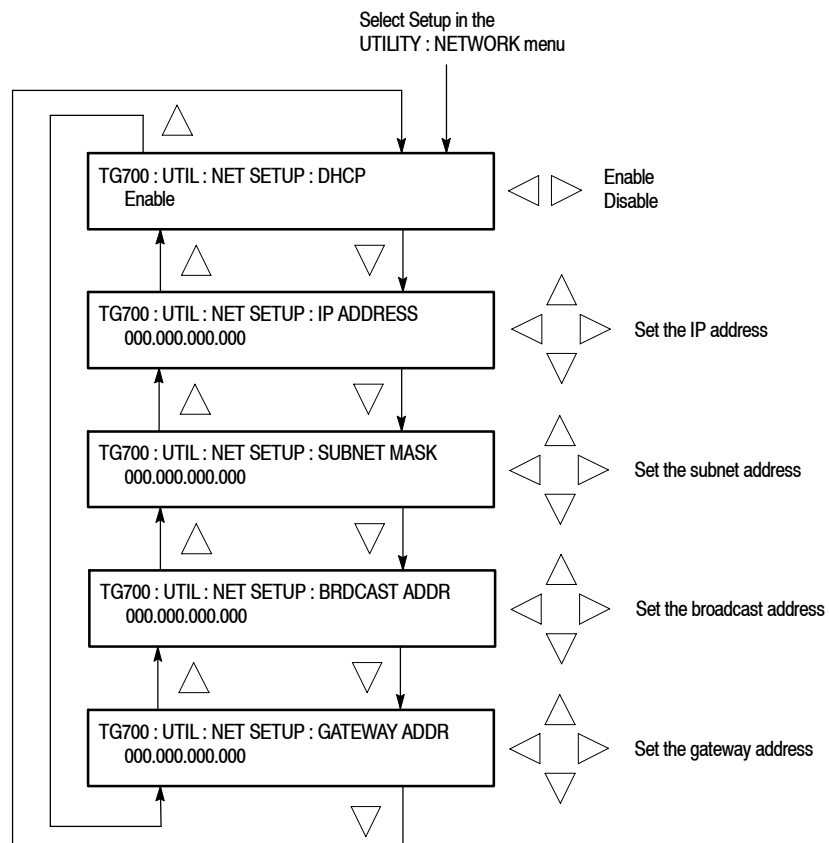

Figure 3-8: NETWORK SETUP submenu

DHCP. Selects valid or invalid IP address settings by DHCP (Dynamic Host Configuration Protocol). Use the left (◀) or right (▶) arrow button to select between **Enable** and **Disable**. Press the ENTER button to implement the selection. If you select Disable in this menu, you will need to set address values in each of the menu items described below.

Refer to the user documentation supplied with your server OS for detailed information about DHCP server functions.

NOTE. *Under some network environments, the TG700 may not be able to get the IP address automatically from a DHCP server. In this case, you need to enter the appropriate address value in each submenu item.*

IP ADDRESS. Sets the IP address of the TG700. Press the ENTER button to enter the edit mode to input the address. Then use the left (◀) or right (▶) arrow button to move the underscore character (_), and use the up (▲) or down (▼) arrow button to enter the value. After you enter the value, press the ENTER button to enable the value. When no value is set, the default value is used. If the DHCP menu item is set to Enable, the IP address automatically obtained from the DHCP server is used.

NOTE. *If you enter blank characters for the IP address, the network function of the TG700 becomes invalid.*

SUBNET MASK. Sets the subnet address of the TG700. Press the ENTER button to enter the edit mode to input the address. Then use the left (◀) or right (▶) arrow button to move the underscore character (_), and use the up (▲) or down (▼) arrow button to enter the value. After you enter the value, press the ENTER button to enable the value. When no value is set, the default value is used. If the DHCP menu item is set to Enable, the subnet address automatically obtained from the DHCP server is used.

BRDCAST ADDR. Sets the broadcast address of the TG700. Press the ENTER button at first to enter the edit mode to input the address. Then use the left (◀) or right (▶) arrow button to move the underscore character (_), and use the up (▲) or down (▼) arrow button to enter the value. After you enter the value, press the ENTER button to enable the value. If the DHCP menu item is set to Enable, the broadcast address automatically obtained from the DHCP server is used.

GATEWAY ADDR. Sets the gateway address of the TG700. Press the ENTER button to enter the edit mode to input the address. Then use the left (◀) or right (▶) arrow button to move the underscore character (_), and use the up (▲) or down (▼) arrow button to enter the value. After you enter the value, press the ENTER button to enable the values.

Refer to *Connecting to a Network* on page 3-15 for detailed information about connecting the TG700 to a PC.

DIAGNOSTICS Submenu

This menu allows you to execute the diagnostic routines for the mainframe and installed modules. Figure 3-9 shows the DIAGNOSTICS submenu.

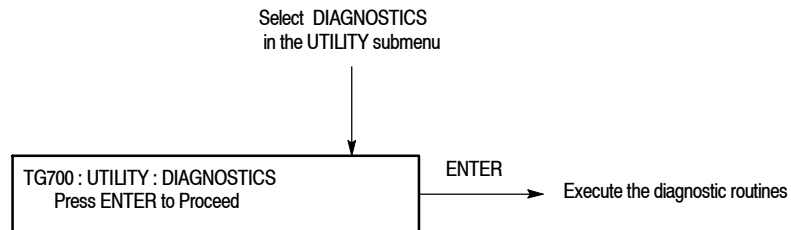

Figure 3-9: DIAGNOSTICS submenu



CAUTION. When you execute the diagnostic routines, be sure to save the current instrument settings to a preset. After the diagnostics is completed, reboot the instrument and then recall the saved settings.

Press the ENTER button to execute the diagnostic routines. If all of the diagnostic routines are completed without any errors, the instrument will display "Pass".

If a diagnostic error is displayed, contact your local Tektronix Field Office or representative.

NOTE. The front-panel buttons are disabled until the diagnostic routines are completed.

Connecting to a Network

The TG700 has a 10 BASE-T port on the rear panel that allows you to control the instrument remotely, using your PC to upload and download various files such as signal files or logo files.

This section provides instructions for connecting the TG700 to a single PC or a network and setting the network parameters for the 10 BASE-T port.

Refer to *Using TG7 Comm for File Transfers* on page 3-27 for detailed information about how to upload and download files using the 10 BASE-T port.

Connecting the TG700 to your PC(s)

The TG700 uses the rear-panel 10 BASE-T port (see Figure 2-2 on page 2-3) to communicate with a PC. Use one of the following two methods to connect the TG700 to your PC(s).

- If you are connecting the TG700 directly to a single PC, use a crossover Ethernet cable to connect between the 10 BASE-T port on the TG700 and the Ethernet port on the PC. If you need to construct your own crossover cable, Figure 3-10 shows the pin connections to change on a straight cable to produce a crossover cable.
- If you are connecting the TG700 to your local Ethernet network, use a straight Ethernet cable to connect between the 10 BASE-T port on the TG700 and the Ethernet hub port of your local network. By connecting to an Ethernet network, you can access the TG700 using any PC on the network.

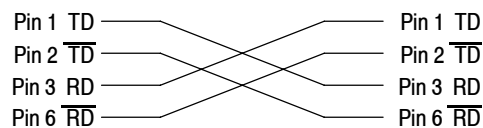

Figure 3-10: Pin connections for a 10BASE-T crossover Ethernet cable

Setting Ethernet Network Parameters

You can set the network parameters for the TG700 using the NETWORK SETUP submenu.

Accessing the NETWORK SETUP Submenu

Perform the following procedure to access the NETWORK SETUP submenu.

1. Press the front-panel **MODULE** button repeatedly to display the mainframe main menu.
2. Use the up (▲) or down (▼) arrow button to select **UTILITY** and then press the **ENTER** button. This accesses the UTILITY submenu.
3. Use the up (▲) or down (▼) arrow button to select **Network**.
4. Use the left (◀) or right (▶) arrow button to select **Setup**. This accesses the NETWORK SETUP submenu shown in Figure 3-11.

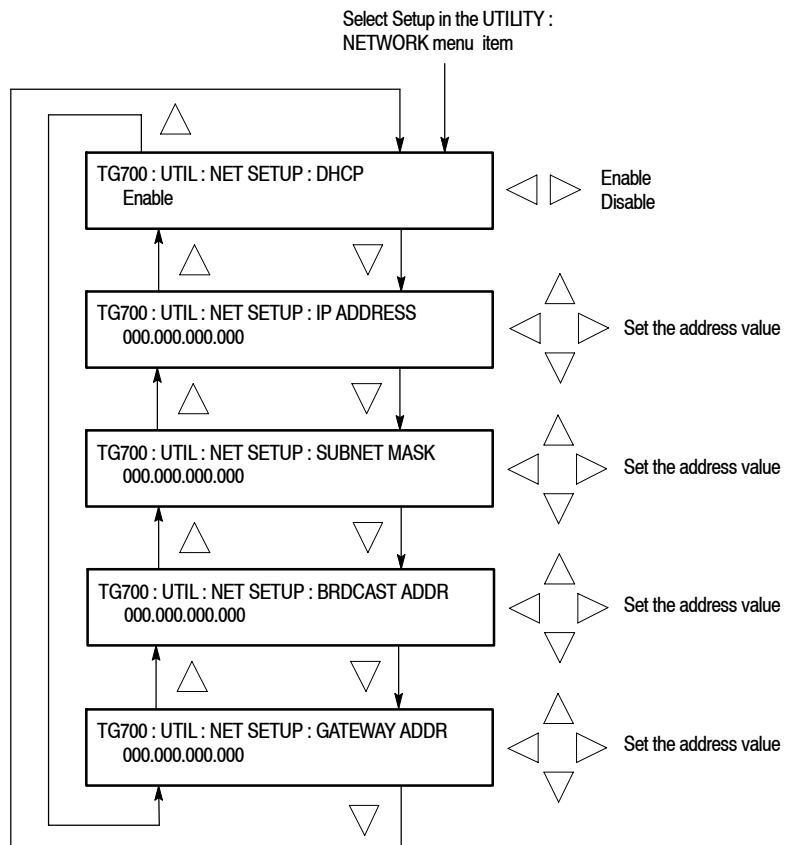

Figure 3- 11: NETWORK SETUP submenu

Setting the Network Parameters

Perform the following procedure to set the network parameters for the TG700. The settings depend on whether a DHCP (Dynamic Host Configuration Protocol) server is in the network connected to the TG700.

When the DHCP server is in the network.

If a DHCP server is in the network, when you select **Enable** in the NET SETUP : DHCP menu item, the TG700 functions as a DHCP client. In this case, you can register the addresses such as the IP address and subnet mask used by the TG700. This way, the TG700 accesses the DHCP server and gets the addresses automatically when connected to the network.

Refer to the user documentation supplied with your server OS for detailed information about DHCP server functions.

NOTE. Under some network environments, the TG700 may not be able to get the IP address automatically from a DHCP server. In this case, you need to enter the appropriate address value in each submenu item.

When the DHCP server is not in the network.

When the DHCP server is not in the network, perform the following procedure to set the network parameters.

1. If you connect the TG700 directory to a single PC:
 - a. Set the **IP ADDRESS** parameter to be the same IP address as the PC's address except for the last number. The last number must be different than the last number in the PC's IP address.
 - b. Set the **SUBNET MASK** parameter to be the same net mask (subnet mask) used by the PC. Do not enter a number if the PC does not have a net mask.
 - c. You do not need to enter a **BRDCAST ADDR** and **GATEWAY ADDR** if you are directly connected to a single PC.
2. If you connect the TG700 to your local Ethernet network, see the *Caution* note below.



CAUTION. To prevent communication conflicts on your Ethernet network, ask your local network administrator for the correct numbers to enter in the NETWORK PARAMETERS submenu if you connect the TG700 to your local Ethernet network.

3. Verify the Ethernet connection by using a ping command from the PC.

Using the General Purpose Interface (GPI)

The 10 BASE-T port of the TG700 can be used as the General Purpose Interface (GPI) by changing the internal jumper settings. When you enable the GPI, you can recall one of the seven presets, output an alarm signal, and display an alarm status on the LCD.

This section describes how to set the GPI and its available features.



CAUTION. *When you enable the GPI, do not connect the TG700 to a network. The network may be damaged.*

NOTE. *When you enable the GPI, you cannot perform the operation using a network such as sending and receiving remote commands or downloading signals.*

After you have enabled the GPI, be sure to apply the GPI label (provided with the instrument) to the rear panel to show that the instrument cannot connect to a network.

Setting the GPI

The GPI can be enabled by the jumper settings of the connectors J000, J002, J004, J006, and J008 on the A10 MAIN board.

Since the A10 MAIN board is located inside the chassis, you need to remove the top cover to change the jumper settings.

Perform the following procedure to remove the top cover and to change the jumper settings. You need a screwdriver with a # 2 Phillips tip to remove the top cover.



CAUTION. *To avoid a shock hazard, be sure to remove the power cord before removing the top cover. Failure to remove the power cord can result in serious injury or death.*

1. Disconnect the power cord from the line voltage source.
2. Use a screw driver with a #2 Phillips tip to remove the two screws securing the front of the top cover to the instrument. See Figure 3-12.

3. Slide the top cover toward the rear, and then lift it off the instrument. See Figure 3-12.

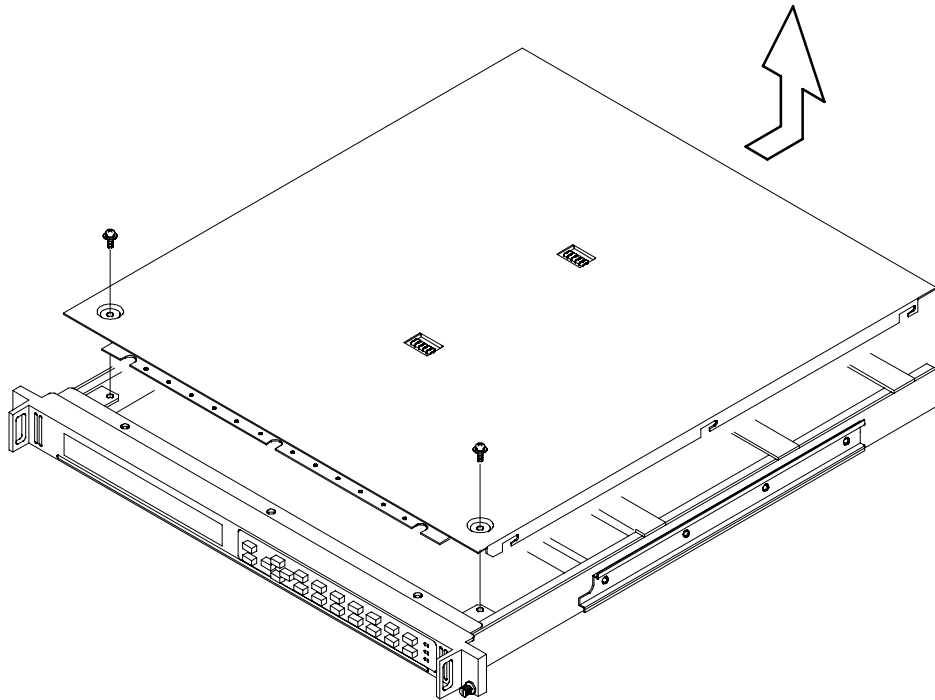

Figure 3- 12: Top cover removal

4. Locate the connectors **J000**, **J002**, **J004**, **J006**, and **J008** on the A10 MAIN board. See Figure 3-13.

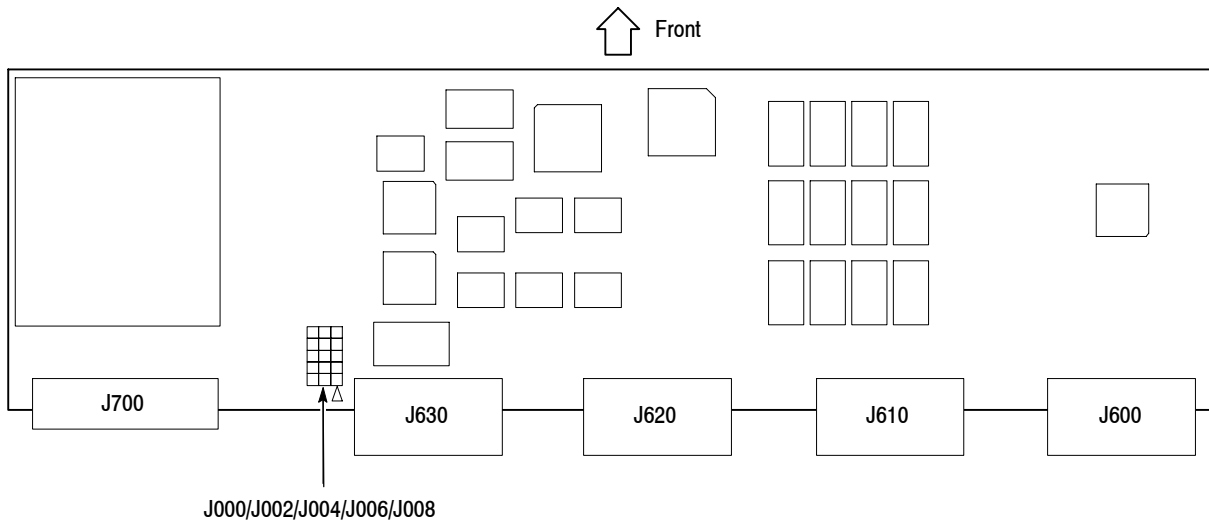

Figure 3-13: Location of the connectors J000/J002/J004/J006/J008

5. Move all of the jumpers from pins 1-2 to pins 3-4. Table 3-1 shows the jumper settings of the connectors and available feature.

NOTE. To enable the GPI, be sure to move all of the jumpers to pins 2-3.

Table 3-1: Jumper settings of the connectors and available feature

Jumper illustration	Jumper setting	Feature
<p>J000 J002 J004 J006 J008</p> <p>3 1</p>	All of the jumpers short pins 1-2. (factory default settings)	LAN (Ethernet)
<p>J000 J002 J004 J006 J008</p> <p>3 1</p>	All of the jumpers short pins 2-3.	GPI

6. After moving the jumpers, place the top cover on the instrument and slide it toward the front.
7. Use a screw driver with a #2 Phillips tip to install the two screws securing the front of the top cover to the instrument.
8. Remove the protective backing from the GPI label provided with the instrument, and then apply it to the rear panel. See Figure 3-14.

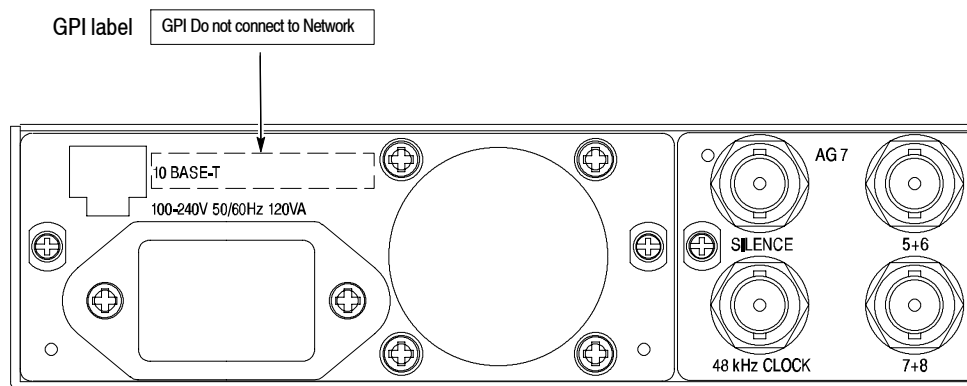
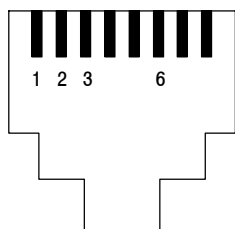

Figure 3- 14: Applying the GPI label to the rear panel

Pin Assignments of the 10 BASE-T Connector

Figure 3-15 shows the pin assignments of the 10 BASE-T connector when it is used as the GPI. The pins 1, 2, and 3 are used to input signals for recalling a preset. The pin 4 is used to output an alarm signal. Frame ground is used for the ground return. When using a shielded LAN cable (shielded twisted pair cable), you can utilize the shield of the cable as ground.



10 BASE-T connector

Pin number	Function	Level
1	Input	High > 1.4 V or open (connected to an internal 10 kΩ pull-up resistor)
2	Input	Low < 0.4 V or ground (input impedance: 10 kΩ)
3	Input	
6	Output	Low < 0.4 V or ground (when drawn 100 mA; maximum on-resistor 4 Ω)

Figure 3- 15: Pin assignments of the 10 BASE-T connector for the GPI

Recalling a Preset

When you enable the GPI, you can recall one of the seven presets by combinations of signal levels for pins 1, 2, and 3 of the 10 BASE-T connector. Table 3-2 shows the combinations of signal levels for the pins and the preset number to be recalled.

Table 3-2: Combinations of signal levels and the corresponding preset

Pin 1	Pin 2	Pin 3	Preset number
High	High	Low	1
High	Low	High	2
High	Low	Low	3
Low	High	High	4
Low	High	Low	5
Low	Low	High	6
Low	Low	Low	7

All of the input signals are active low; when the signal level(s) for the specified pin(s) goes from High to Low, the corresponding preset is recalled. For example, when the signal level for pin 3 goes from High to Low, the preset 1 is recalled.

NOTE. *Since the signal transition cannot be detected on the edge of the signal, the signal level needs to hold. It requires about 0.5 seconds to recall a preset, and then the settings of the TG700 change. The required time to change the settings depends on the contents of a preset.*

Outputting an Alarm Signal

When you enable the GPI, the TG700 can output an alarm signal from pin 6 on the 10 BASE-T connector when one of the following internal errors occur:

- When the fan stops working.
- When a genlock signal is not connected.
- When the TG700 does not lock to a genlock signal.
- When the frequency of the genlock signal and the internal reference shift considerably, and the TG700 seems to be near loss of lock.

The output signal is active low; the signal level for pin 6 goes from High to Low when any errors occur.

The alarm signal output can be enabled using the GPI ALARM OUTPUT menu item in the UTILITY submenu. Refer to *GPI ALARM OUTPUT* on page 3-25 for more information.

ALARM Menu

When the GPI is enabled, the ALARM menu items are displayed instead of the UTILITY menu item. The ALARM menu allows you to enable or disable the alarm signal output, to reset the alarm signal output, and to display the alarm status. Figure 3-16 shows the ALARM menu.

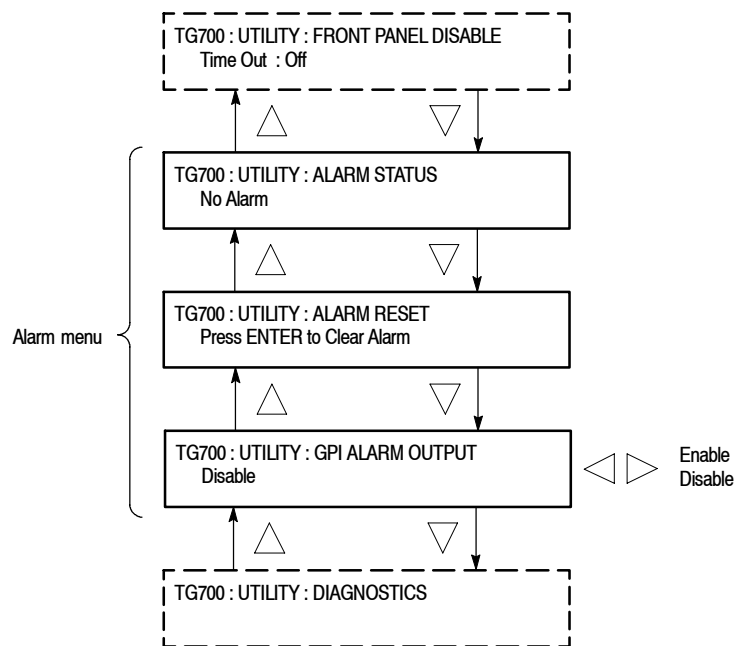

Figure 3-16: ALARM menu

ALARM STATUS. Displays the alarm status detected inside the instrument. The possible messages for the status are as follows:

- **No Alarm:** No errors have been detected.
- **Genlock : Near Loss of Lock:** The frequency of the genlock signal and the internal reference signal shift considerably, and the TG700 seems to be near loss of lock. If this happens it is recommended that you check the frequency of the genlock signal or internal reference signal of the TG700.
- **Genlock : Loss of Lock:** The TG700 does not lock to a genlock signal.
- **Genlock : No Signal:** A genlock signal is not connected.
- **Fan Fault:** The fan on the rear panel stops working.

NOTE. *In the alarm status display, the instrument displays an error message that has been detected in the past. In order to display the latest message, you need to access the other menu item (press the CANCEL button) and to return to the ALARM STATUS menu again.*

ALARM RESET. Resets the alarm status. The TG700 holds the alarm status even if the cause of the alarm is eliminated. Use this menu item when you need to reset the status. If the cause of the error is not eliminated, the alarm status is set again when you reset the status.

GPI ALARM OUTPUT. Enables or disables the alarm signal output. Use the left (◀) or right (▶) arrow button to select between **Enable** and **Disable**. For **Enable**, an alarm signal is output from pin 6 of the 10 BASE-T connector when any error is detected inside the instrument. For **Disable**, the alarm signal output is disabled.

Press the **ENTER** button to confirm the selection.

Using TG7 Comm for File Transfers

TG7 Comm, a standard accessory with the TG700, is a software application for a PC using the Microsoft Windows system. TG7 Comm provides the capability to transfer signal, logo, preset, frame picture, or sequence files between a PC and the TG700 using the Ethernet interface.

This section provides the following information:

- PC system requirements
- Installation instruction and Ethernet setup
- Starting and exiting TG7 Comm
- Elements of TG7 Comm window
- Using the TG7 Comm menus
- TG7 Comm tutorials

PC System Requirements

Your PC requires the following minimum system requirements to load and operate the TG7 Comm application:

- Microsoft Windows 95, 98, 2000, or NT4.0 (for Windows 95 or NT 4.0, Internet Explorer 4.01 or later needs to be installed)
- Ethernet interface

Installation Instructions and Ethernet Setup

This subsection provides the following instructions: installing the TG7 Comm application on your PC, creating a desktop shortcut icon on the PC to run TG7 Comm, connecting your PC(s) to the TG700 using the Ethernet port, and setting the required Ethernet parameters.

Installing TG7 Comm

The following installation instructions assume that you are familiar with the basics of using the Windows operating system. If necessary, read your Windows user documentation before installing TG7 Comm.

Perform the following procedure to install TG7 Comm:

1. Be sure that your PC meets the requirements listed under *PC System Requirements* above before proceeding with the installation.
2. Insert the TG700 Signal Generator Platform Software Library CD-ROM into a CD-ROM drive on your PC.
3. Double-click the **My computer** icon and the **CD-ROM drive** icon on the PC desktop. The PC will display the contents of the TG700 Signal Generator Platform Software Library CD-ROM.
4. Double-click the **Tools** folder and the **TG7 Comm** folder on the PC desktop. The PC will display the contents of the TG7 Comm folder.
5. Double-click the **Setup.exe** icon in the folder.

This copies initial files of the TG7 Comm application. For a while, the Welcome window appears on the PC desktop.

6. Read the displayed information, and then click the **Next>** button to proceed with the installation.

The PC will display the Choose Destination Location window. The default directory location for the application is displayed. If you want to install TG7 Comm in a custom location, click the **Browse...** button, and then select or create a custom directory location.

7. Click the **Next>** button to proceed.

The PC will display the Select Program Folder window. The default name for the program folder is displayed. If you want to change the name, type in a new name or select a name from the Existing Folders list.

8. Click the **Next>** button to proceed. The PC will display the Start Copying Files window.
9. Click the **Next>** button to start the installation.

If the installation is successful, the Setup Complete windows is displayed.

Creating a Desktop Shortcut Icon

Perform the following procedure to create an icon on your PC desktop that you can use to run the TG7 Comm application.

1. On your PC display, move the mouse cursor to any unoccupied desktop area, and then click the right mouse button to open the desktop menu.
2. From the desktop menu select **New**, and then select **Shortcut** to open the Create Shortcut dialog box.
3. Click the **Browse...** button in the Create Shortcut dialog box.

4. Use the Browse dialog box to locate the TG7 Comm directory.
 - a. If you installed the TG7 Comm application using the default directory location and the default folder name in the installation procedure, select the following directory folders in order: **Program Files**, **Tektronix**, **TG700**, and **TG7 Comm**.
 - b. If you installed the TG7 Comm application to a custom location or gave the application folder a custom name, you will need to select your custom directory path.
 - c. You should now be at a location in the PC directory structure where the browse list box shows the **tg7comm.exe** file.
5. Select the **tg7comm.exe** file (tg7comm.exe will be displayed in the file name box), and then click the **Open** button. The directory path to the tg7comm.exe file will now be displayed in the Command Line box of the Create Shortcut dialog box.
6. Click the **Next>** button in the Create Shortcut dialog box. The default name of the shortcut icon is now displayed in the dialog box. You can edit the icon name to suit your needs or accept the default name.
7. Click the **Finish** button to finish creating the desktop shortcut icon. The tg7comm.exe shortcut icon will now appear on the PC desktop. You can start the TG7 Comm application by double-clicking the **tg7comm.exe** (or your custom name) shortcut icon.

Connecting Your PC(s) to the TG700

TG7 Comm uses the rear-panel 10 BASE-T port on the TG700 to communicate with a PC.

Refer to *Connecting to a Network* on page 3-15 for detailed information about how to connect your PC(s) to the TG700.

Setting Ethernet Network Parameters

Before you can use TG7 Comm to transfer files between the TG700 and your PC(s), you must set the Ethernet network parameters for both the TG700 and the TG7 Comm application.

NOTE. Use the *ping* command from the PC to verify network communications after you set the Ethernet network parameters for the TG700 and for the TG7 Comm application.

Ethernet Parameters for the TG700. The Ethernet network parameters for the TG700 can be set using the **NETWORK SETUP** submenu in the **UTILITY** main menu. Refer to *Setting Ethernet Network Parameters* on page 3-16 for detailed information about how to set the network parameters.

Ethernet Parameters for TG7 Comm. Perform the following procedure to set the Ethernet network parameters for the TG7 Comm application:

1. Select **Network** from the **Utility** menu of the TG7 Comm application. This will open the Ethernet dialog box shown in Figure 3-17.
2. Use the **IP Address** field in the dialog box to enter the IP address that you assigned to the TG700.
3. Click the **OK** button to accept the settings and close the dialog box.

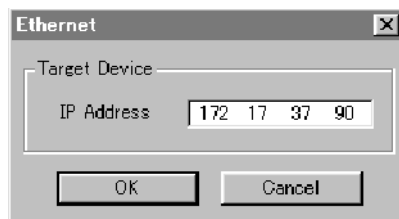

Figure 3- 17: Ethernet dialog box for TG7 Comm

Starting and Exiting TG7 Comm

When you complete the installation procedure, you can use any of the following methods to start the TG7 Comm application:

- Double-click the tg7comm.exe shortcut icon on the PC desktop that you created during the installation procedure.
- Double-click the tg7comm.exe file name in the Program Manager window.
- Select tg7comm from the Start - Programs menu.

To exit (quit) the TG7 Comm application, select **Exit** from the **File** menu command list of the application.

Elements of the TG7 Comm Window

Figure 3-18 shows the TG7 Comm application window. Table 3-3 provides a description of the elements in the application window.

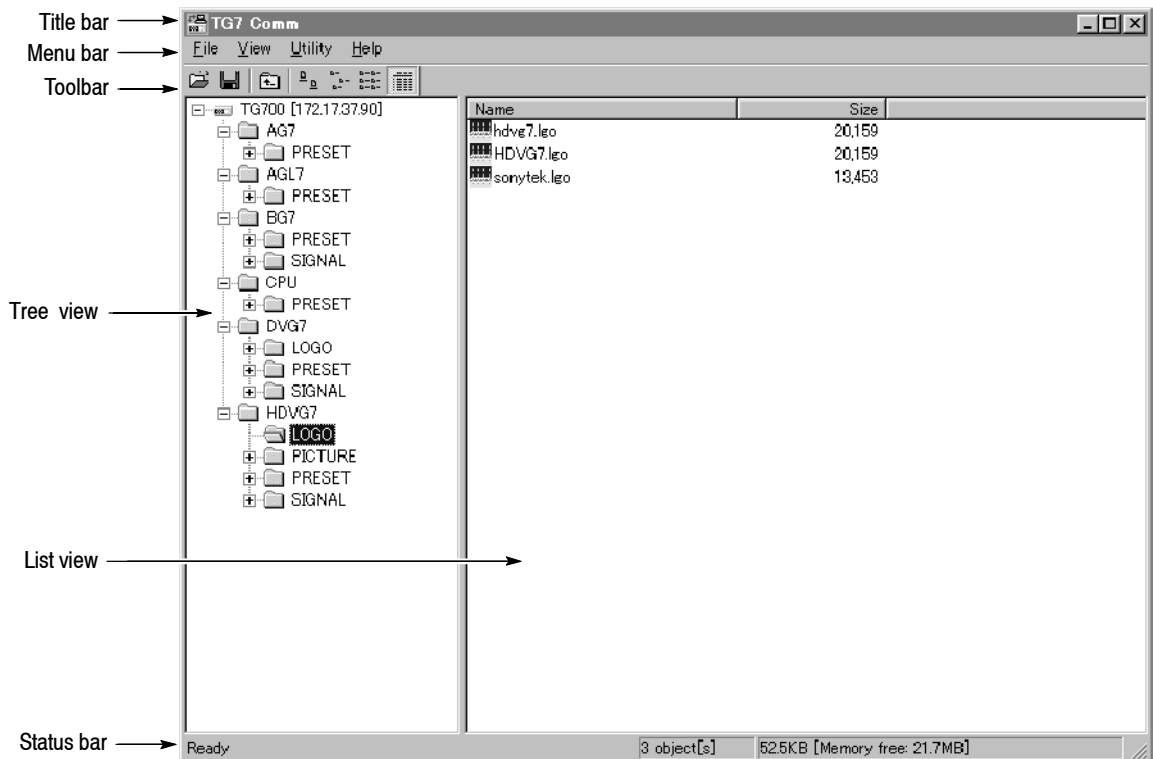









Figure 3-18: TG7 Comm application window

Table 3-3: Elements of the TG7 Comm window

Element	Description
Title bar	The Title bar displays the name of the application and contains the standard window-sizing boxes for Windows.
Menu bar	The Menu bar displays the names of the four pull-down menus. Refer to <i>Using TG7 Comm Menus</i> on page 3-33 for detailed information about the functions available in the menus.
Toolbar	The Toolbar provides shortcut buttons for many of the most often used menu commands. Click a toolbar button to select the corresponding command. You can toggle the toolbar display on and off using the Toolbar command in the View pull-down menu. Table 3-4 describes the function of each toolbar button.
Tree view	The Tree view displays the file structure in the TG700. The contents of the selected directory is displayed in the List view. The IP address of the selected TG700 is displayed at the top of the Tree.
List view	The List view displays the contents of the selected directory in the Tree view. You can use the View pull-down menu to alter the display in the List view.
Status bar	The Status bar displays the number of files (objects) stored in the selected directory, the total file size of the selected directory, and the amount of free disk space in the TG700's system memory.

Table 3-4: Toolbar button descriptions

Icon	Name	Function
	PC to TG	Equivalent to the PC to TG command in the File menu.
	TG to PC	Equivalent to the TG to PC command in the File menu.
	Up One Level	Moves from the current folder to the upper level folder.
	Large Icons	Equivalent to the Large Icons command in the View menu.
	Small Icons	Equivalent to the Small Icons command in the View menu.
	List	Equivalent to the List command in the View menu.
	Details	Equivalent to the Details command in the View menu.

Using the TG7 Comm Menus

The Menu bar displays the names of the four pull-down menus: File, View, Utility, and Help. This section describes the function of each selection in these menus.

File Menu The File menu contains commands for managing file operations and for exiting the TG7 Comm application. Table 3-5 describes each of the File menu commands.

Table 3-5: TG7 Comm File menu commands

Command	Function
PC to TG	Displays the PC to TG Download dialog box where you can select the file you want to transfer from your PC to the directory in the TG700 selected in the Tree view.
TG to PC	When you select this command after you highlight a file in the List view of the TG7 Comm application, the TG to PC Upload dialog box appears where you can select a destination path and file name for the file you want to transfer to your PC.
New	Creates a new folder in the currently selected directory of the TG700.
Delete	Deletes the file or empty folder currently selected in the TG700.
Rename	Renames the file name or folder name currently selected in the TG700.
Exit	Exits the TG7 Comm application.

View Menu The View menu contains commands that control the appearance of the TG7 Comm application window. Table 3-6 describes each of the View menu commands.

Table 3-6: TG7 Comm View menu commands

Command	Function
Toolbar	Toggles the display of the Toolbar on and off in the application window. A check mark precedes the command in the menu when the Toolbar is selected for display.
Status Bar	Toggles the display of the Status bar on and off in the application window. A check mark precedes the command in the menu when the Status bar is selected for display.
Large Icons	Causes the application to display files or folders in the List view using large icons. A check mark precedes the command in the menu when Large Icons is selected.
Small Icons	Causes the application to display files or folders in the List view using small icons. A check mark precedes the command in the menu when Small Icons is selected.
List	Causes the application to display files or folders in the List view in a vertical list form. A check mark precedes the command in the menu when List is selected.
Details	Causes the application to display files or folders in the List view in a detailed column format which includes the file size and last modified date of each file. A check mark precedes the command in the menu when Details is selected. When you select Details, you can click on the column names in the List view to reorder the contents of the directory by file name, by file size, or by file date.
Arrange Icons	Sets the display order for the folders and files in the List view. You can arrange the List view display by Name, Size, or Date.
Refresh	Refreshes the file display in the List view.

Utility Menu The Utility menu contains commands for setting the network parameters.

Table 3-7: TG7 Comm Utility menu commands

Command	Function
Network	Opens the Ethernet dialog box where you can set the IP address of the target TG700. Refer to <i>Ethernet Parameters for TG7 Comm</i> on page 3-30 for more information.
Check Error	Opens the TG Error dialog box which lists the error(s) detected in the TG700.
Options	Opens the Set Options dialog box where you can specify which text editor application you will use to describe a sequence file.

Help Menu The Help menu About... command displays information including the TG7 Comm software version number and copyright information.

You can set the network parameters for the TG700 using the NETWORK SETUP submenu.

TG7 Comm Tutorials

After you have connected the TG700 to the PC using an Ethernet cable and set the required network parameters, you can use TG7 Comm to transfer files between the PC and the TG700.

NOTE. *The convention used by the TG7 Comm application is to call file transfers from the PC to the TG700 a “download,” and to call file transfers from the TG700 to the PC an “upload.”*

You can download and upload the following types of files:

- Signal file (*.dnl)
- Logo file (*.lgo)
- Frame picture file (*.pic)
- Preset file (*.p00 to *.p14)
- Sequence file (*.seq)



CAUTION. Do not execute any operations except for Delete and Rename for a *.cmp file in the SIGNAL folder of each module.

Downloading a File to the TG700

This subsection provides the procedures to download a signal file, logo file, frame picture file, preset file, or sequence file from the PC to the TG700.

NOTE. When you download file(s) to the TG700, make sure that the TG700 has at least 1 MB of free memory space. This information is displayed on the status bar in the application window.

Signal File, Logo File, Frame Picture File, or Preset File. Perform the following steps to download a signal file, logo file, frame picture file, or preset file from the PC to the TG700.

1. In the Tree view of the TG7 Comm application, select the destination folder for the file you are going to download to the TG700.
2. Select **PC to TG** from the **File** pull-down menu to open the PC to TG Download dialog box.
3. In the PC to TG Download dialog box, select the file on the PC that you want to download and the type of file, and then click the **Download** button to open the dialog box to confirm the file name. See Figure 3-19.
4. In the dialog box, confirm the file and then click the **OK** button to download the file.



Figure 3- 19: File name confirmation dialog box

Sequence File. Perform the following steps to download a sequence file from the PC to the TG700.

1. In the Tree view of the TG7 Comm application, select the destination folder for the file you are going to download to the TG700.

2. Select **PC to TG** from the **File** pull-down menu to open the PC to TG Download dialog box.
3. In the PC to TG Download dialog box, select the file on the PC that you want to download and the type of file (*.seq), and then click the **Download** button to open the Sequence File dialog box shown in Figure 3-20.
4. In the Sequence File dialog box, confirm the sequence file that you want to download.
5. When you click the **Edit** button, you can view the content of the sequence file and edit it.
6. Click the **OK** button to download the file.



Figure 3-20: Sequence File dialog box

Uploading a File to the PC

The procedure for uploading a file from the TG700 to the PC is the same for a signal file, logo file, frame picture file, preset file, or sequence file.

Perform the following steps to upload a signal file, logo file, frame picture file, preset file, or sequence file from the TG700 to the PC:

1. In the List view of the TG7 Comm application, select the file you want to upload to the PC.
2. Select **TG to PC...** from the **File** pull-down menu to open the TG to PC Upload dialog box.
3. In the TG to PC Upload dialog box, specify the destination folder for the file you are going to upload to your PC.
4. Click the **Upload** button to upload the file from the TG700 to your PC.

About Uploading a Preset File. When you save instrument settings as a preset, separate preset files are created for each module. Therefore, when you upload a preset file using the TG7 Comm application, you need to create the folders for each module and upload all the files in it.

Once you have uploaded a preset file from the TG700 to the PC, you can download the file to another TG700 with the same configuration and use it as a known settings.

A preset file can be easily backed up and restored by the TG7 Backup and TG7 Restore applications. Refer to *Using the File Copy Tools* beginning on page 3-69 for more information about how to backup and restore a preset file.

Using Frame Picture Generator (Option FP Only)

Frame Picture Generator, available as Option FP when you order a TG700, is a software application for a PC using the Microsoft Windows system. Frame Picture Generator provides the capability to convert a Windows bitmap file (.bmp) to a frame picture file (.pic) that can be used by the TG700. Using this application, you can convert a natural picture or a test pattern in bitmap format to a frame picture file and output it as a picture.

This section provides the following information:

- PC system requirements
- Installation instructions
- Starting and exiting Frame Picture Generator
- Elements of the Frame Picture Generator window
- Using the Frame Picture Generator menus
- Frame Picture Generator tutorials

PC System Requirements

Your PC requires the following minimum system requirements to load and operate the Frame Picture Generator application:

- Microsoft Windows 95, 98, 2000, or NT4.0
- True Color (more than 24 bits) display mode

Installation Instructions

This subsection provides the following instructions: installing the Frame Picture Generator application on your PC and creating a desktop shortcut icon on the PC to run Frame Picture Generator.

Installing Frame Picture Generator

The following installation instructions assume that you are familiar with the basics of using the Windows operating system. If necessary, read your Windows user documentation before installing Frame Picture Generator.

Perform the following procedure to install Frame Picture Generator:

1. Be sure that your PC meets the requirements listed under *PC System Requirements* on Page 3-39 before proceeding with the installation.
2. Insert the **TG700 Signal Generator Platform Software Library** CD-ROM into a CD-ROM drive on your PC.
3. Double-click the **My computer** icon and the **CD-ROM drive** icon on the PC desktop. The PC will display the contents of the TG700 Signal Generator Platform Software Library CD-ROM.
4. Double-click the **Tools** folder and **Frame Picture Generator** folder on the PC desktop. The PC will display the contents of the Frame Picture Generator folder.
5. Double-click the **Setup.exe** icon in the folder.

This copies initial files of the Frame Picture Generator application. For a while, the **Welcome** window appears on the PC desktop.

6. Read the displayed information, and then click the **Next>** button to proceed with the installation.

The PC will display the Choose Destination Location window. The default directory location for the application is displayed. If you want to install Frame Picture Generator in a custom location, click the **Browse...** button, and then select or create a custom directory location.

7. Click the **Next>** button to proceed.

The PC will display the Select Program Folder window. The default name for the program folder is displayed. If you want to change the name, type in a new name or select a name from the Existing Folders list.

8. Click the **Next>** button to proceed. The PC will display the Start Copying Files window.
9. Click the **Next>** button to start the installation.

If the installation is successful, the Setup Complete windows is displayed.

Creating a Desktop Shortcut Icon

Perform the following procedure to create an icon on your PC desktop that you can use to run the Frame Picture Generator application.

1. On your PC display, move the mouse cursor to any unoccupied desktop area, and then click the right mouse button to open the desktop menu.
2. From the desktop menu select **New**, and then select **Shortcut** to open the Create Shortcut dialog box.

3. Click the **Browse...** button in the Create Shortcut dialog box.
4. Use the Browse dialog box to locate the Frame Picture Generator directory.
 - a. If you installed the Frame Picture Generator application using the default directory location and the default folder name in the installation procedure, select the following directory folders in order: **Program Files**, **Tektronix**, **TG700**, and **FRAMEGEN**.
 - b. If you installed the Frame Picture Generator application to a custom location or gave the application folder a custom name, you will need to select your custom directory path.
 - c. You should now be at a location in the PC directory structure where the browse list box shows the **FrameGEN.exe** file.
5. Select the **FrameGEN.exe** file (FrameGEN.exe will be displayed in the file name box), and then click the **Open** button. The directory path to the FrameGEN.exe file will now be displayed in the Command Line box of the Create Shortcut dialog box.
6. Click the **Next>** button in the Create Shortcut dialog box. The default name of the shortcut icon is now displayed in the dialog box. You can edit the icon name to suit your needs or accept the default name.
7. Click the **Finish** button to finish creating the desktop shortcut icon. The FrameGEN.exe shortcut icon will now appear on the PC desktop. You can start the Frame Picture Generator application by double-clicking the **FrameGEN.exe** (or your custom name) shortcut icon.

Starting and Exiting Frame Picture Generator

When you complete the installation procedure, you can use any of the following methods to start the Frame Picture Generator application:

- Double-click the FrameGEN.exe shortcut icon on the PC desktop that you created during the installation procedure.
- Double-click the FrameGEN.exe file name in the Program Manager window.
- Select FrameGen from the Start - Programs menu.

To exit (quit) the Frame Picture Generator application, select **Exit** from the **File** pull-down menu or click the **Exit** button on the toolbar.

Elements of the Frame Picture Generator Window

Figure 3-21 shows the Frame Picture Generator application window. Table 3-8 provides a description of the elements in the application window.

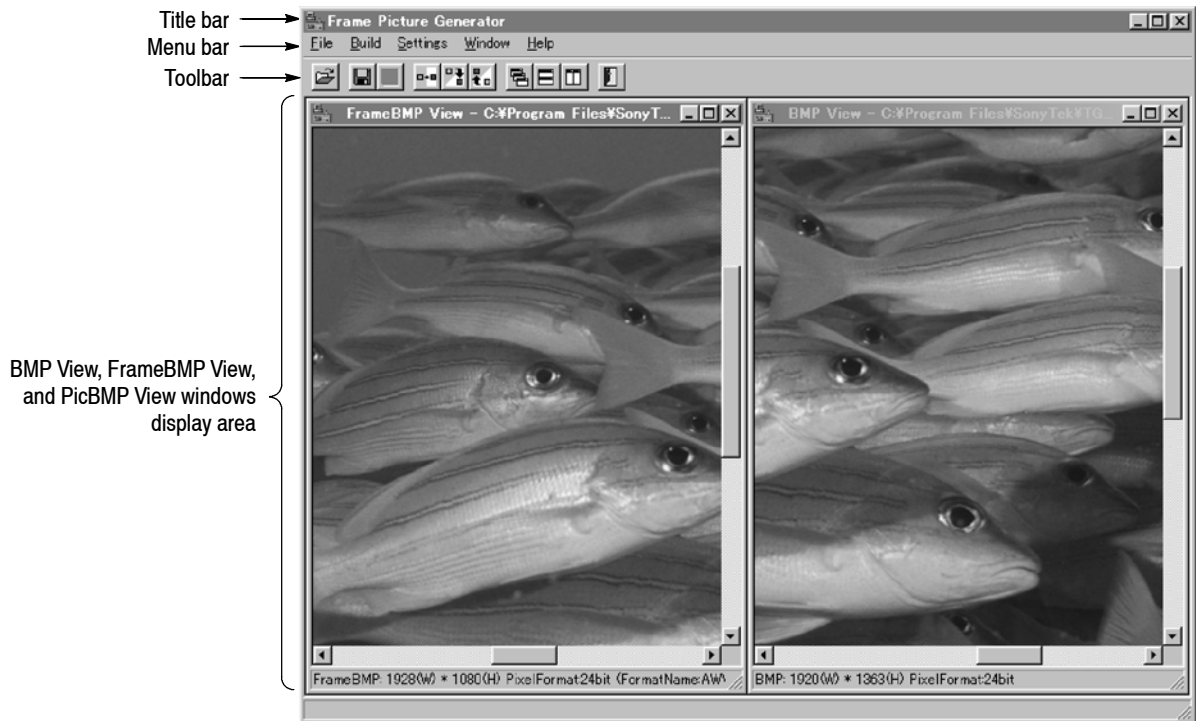

Figure 3-21: Frame Picture Generator application window











Table 3-8: Elements of the Frame Picture Generator window

Element	Description
Title bar	The Title bar displays the name of the application and contains the standard window-sizing boxes for Windows.
Menu bar	The Menu bar displays the names of the five pull-down menus. Refer to <i>Using the Frame Picture Generator Menus</i> on page 3-44 for detailed information about the functions available in the menus.
Toolbar	The Toolbar provides shortcut buttons for many of the most often used menu commands. Click a toolbar button to select the corresponding command. Table 3-9 describes the function of each toolbar button.

Table 3-8: Elements of the Frame Picture Generator window (Cont.)

Element	Description
BMP View window	The BMP View window displays the selected bitmap image before conversion.
FrameBMP View window	The FrameBMP View window displays the frame bitmap image converted to the specified video format size.
PicBMP View window	The PicBMP View window displays the frame picture image converted to the bitmap file.

Table 3-9: Toolbar button descriptions

Icon	Name	Function
	Open	Equivalent to the Open command in the File menu.
	Save Frame Bmp As	Equivalent to the Save Frame Bmp As command in the File menu.
	Save Pic Bmp As	Equivalent to the Save Pic Bmp As command in the File menu.
	Build Frame Bmp	Equivalent to the Build Frame Bmp command in the Build menu.
	Build Pic File	Equivalent to the Build Pic File command in the Build menu.
	Build Pic Bmp	Equivalent to the Build Pic Bmp command in the Build menu.
	Cascade	Equivalent to the Cascade command in the Window menu.
	Horizontal	Equivalent to the Horizontal command in the Window menu.
	Vertical	Equivalent to the Vertical command in the Window menu.
	Exit	Equivalent to the Exit command in the File menu.

Using the Frame Picture Generator Menus

The Menu bar displays the names of the five pull-down menus: File, Build, Settings, Window, and Help. This section describes the function of each selection in these menus.

File Menu The File menu contains commands for managing file operations and for exiting the Frame Picture Generator application. Table 3-10 describes each of the File menu commands.

Table 3- 10: Frame Picture Generator File menu commands

Command	Function
Open	Opens a bitmap file. When you select a bitmap file, the image is displayed in the BMP View window.
Save Frame Bmp As	Saves the frame bitmap image displayed in the FrameBMP View window as a bitmap file.
Save Pic Bmp As	Saves the frame picture image displayed in the PicBMP View window as a bitmap file.
Exit	Exits the Frame Picture Generator application.

Build Menu The Build menu contains commands that create a frame bitmap file or frame picture file and convert a frame picture file to a bitmap file. Table 3-11 describes each of the Build menu commands.

Table 3- 11: Frame Picture File Build menu commands

Command	Function
Build Frame Bmp	Converts the bitmap image displayed in the BMP View window to the bitmap file with the specified video format size.
Build Pic File	Converts the frame bitmap file displayed in the FrameBMP View window to the frame picture file (.pic) that can be used by the TG700. Since the AVG7 module outputs a signal by 2-time over sampling technique, a 1 pixel of a bitmap image corresponds to 2 samples of the signal. Therefore, when creating a frame picture file for the AVG7 module, the application uses a 1 pixel of a bitmap image twice.
Build Pic Bmp	Converts the selected frame picture file (.pic) to the bitmap file and displays its image in the PicBMP View window. Note that this command cannot reproduce the original bitmap file completely because the data of the frame picture file is changed when it is converted from the bitmap file. This command is useful when you want to check any frame picture images on the PC.

Settings Menu

The Settings menu contains commands for setting the video format size and background color. Table 3-12 describes each of the Settings menu commands.

Table 3-12: Frame Picture Generator Settings menu commands

Command	Function
Background	Specifies the color used for the background of the bitmap image.
Filter	Eliminates unnecessary high frequency components contained in the bitmap image. These high frequency components derive from rapid changes of intensity or hue in the image generated by using a graphic program. This command is only available for the video format sizes of the DVG7 and HDVG7.
Format	Specifies the video format size when the frame bitmap is created.

Window Menu

The Window menu contains commands for controlling the appearance of the view windows. Table 3-13 describes each of the Window menu commands.

Table 3-13: Frame Picture Generator Window menu commands

Command	Function
Cascade	Arranges the view windows so that they overlap one another.
Horizontal	Arranges the view windows horizontally.
Vertical	Arranges the view windows vertically.
Minimize All	Minimizes the view windows.
Arrange Icon	When the view windows are minimize, arranges their title bars.

Help Menu

The Help menu About FrameGen command displays information including the Frame Picture Generator software version number and copyright information.

Frame Picture Generator Tutorials

This subsection describes the basics of operating the Frame Picture Generator application.

Creating a Frame Picture File

Perform the following steps to create a frame picture file (.pic) from a Windows bitmap file (.bmp).

1. Select **Open** from the **File** pull-down menu to open the Bitmap File dialog box.
2. In the Bitmap File dialog box, select the bitmap file on the PC that you want to convert, and then click the **Open** button. This will display the bitmap image in the BMP View window.
3. Select **Background** from the **Settings** pull-down menu to specify the background color for the frame bitmap.
4. Select **Format** from the **Settings** pull-down menu to select the video format size when the frame bitmap is created.
5. Select **Build Frame Bmp** from the **Build** pull-down menu. This will display the frame bitmap image converted to the specified video format size in the FrameBMP View window.
6. Select **Build Pic File** from the **Build** pull-down menu to convert the frame bitmap file to the frame picture file. While the conversion is in progress, the BUILDING PIC FILES dialog box shown in Figure 3-22 appears.

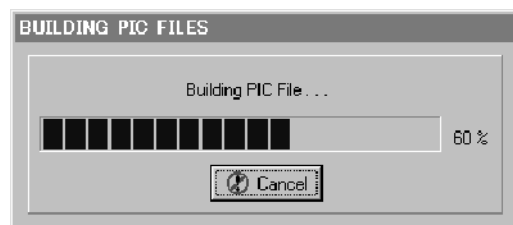

Figure 3-22: BUILDING PIC FILES dialog box

7. When the file conversion is completed, the Pic File dialog box appears.
8. In the dialog box specify the destination folder where you want to save the frame picture file, and the file name.
9. Click the **Save** button to save the file.

Downloading a Frame Picture File and Outputting the Picture

A frame picture file created by Frame Picture Generator is output as a picture by downloading to the TG700.

NOTE. *Make sure to download a frame picture file to a folder for a generator module that can output the correct video format for the frame picture. If the video format for the frame picture file is different from the video format for the generator module, the picture is not output correctly.*

Note for Downloading a Frame Picture File. It is recommended that you download up to 32 MB of frame picture files to the TG700 (the amount of free space in the TG700's system memory can be confirmed on the status bar in the TG7 Comm application).

Total number of lines of frame pictures and test signals that can be downloaded into a module are 4096. Since, line numbers vary depending on a module and signal format, the number of frame picture files that can be downloaded into each module are as follows:

- AVG7: 7 files
- AWVG7: 3 files
- DVG7: 7 files
- HDVG7: 3 files

NOTE. *The flash memory of the TG700 is shared among system files, test signal files, and frame picture files. Therefore, if you use the whole free memory space for frame pictures, system files may not be installed when upgrading the instrument, or additional test signals may not be installed.*

If you have more pictures to be output, you can output them by saving another folder and then assigning it to the front-panel button.

Downloading a Frame Picture File to the TG700. Perform the following steps to download a frame picture file from the PC to the TG700:

1. Start the TG7 Comm application after you connect your PC and TG700 using the appropriate Ethernet cable.

Refer to *Using TG7 Comm for File Transfers* on page 3-27 for detailed information about the TG7 Comm application.

2. Create a folder corresponding to a format name (for example **1080_60i**) under the **PICTURE** folder of the appropriate generator module.
3. Download the frame picture file to the folder using the **PC to TG** command of the TG7 Comm application.

Outputting the Picture. Perform the following steps to output the frame picture file as a picture.

1. Assign the frame picture file to the **OTHER** test signal button on the front panel.

Refer to the *SIGNAL KEY ASSIGN Submenu* on page 3-9 about how to assign a frame picture file to the OTHER test signal button.

2. Press the front-panel **MODULE** button to select the module from which you want to output the picture.
3. Press the front-panel **FORMAT** button to select the video format for the frame picture file.
4. Press the **OTHER** test signal button.
5. Press the left (◀) or right (▶) arrow button, or the **OTHER** test signal button repeatedly to select the picture that you want to output.

Using Logo Generator

Logo Generator, a standard accessory with the TG700, is a software application for a PC using the Microsoft Windows system. Logo Generator provides the capability to convert a Windows bitmap file (.bmp) to a logo file (.lgo) that can be used with the logo overlay feature of the DVG7 or HDVG7 module.

This section provides the following information:

- PC system requirements
- Installation instructions
- Starting and exiting Logo Generator
- Elements of Logo Generator window
- Using the Logo Generator menus
- Logo Generator tutorials

PC System Requirements

Your PC requires the following minimum system requirements to load and operate the Logo Generator application:

- Microsoft Windows 95, 98, 2000, or NT4.0

Installation Instructions

This subsection provides the following instructions: installing the Logo Generator application on your PC and creating a desktop shortcut icon on the PC to run Logo Generator.

Installing Logo Generator

The following installation instructions assume that you are familiar with the basics of using the Windows operating system. If necessary, read your Windows user documentation before installing Logo Generator.

Perform the following procedure to install Logo Generator:

1. Be sure that your PC meets the requirements listed under *PC System Requirements* above before proceeding with the installation.
2. Insert the **TG700 Signal Generator Platform Software Library** CD-ROM into a CD-ROM drive on your PC.

3. Double-click the **My computer** icon and the **CD-ROM drive** icon on the PC desktop. The PC will display the contents of the TG700 Signal Generator Platform Software Library CD-ROM.
4. Double-click the **Tools** folder and **Logo Generator** folder on the PC desktop. The PC will display the contents of the LogoGen folder.
5. Double-click the **Setup.exe** icon in the folder.

This copies initial files of the Logo Generator application. For a while, the Welcome window appears on the PC desktop.

6. Read the displayed information, and then click the **Next>** button to proceed with the installation.

The PC will display the Choose Destination Location window. The default directory location for the application is displayed. If you want to install Logo Generator in a custom location, click the **Browse...** button, and then select or create a custom directory location.

7. Click the **Next>** button to proceed.

The PC will display the Select Program Folder window. The default name for the program folder is displayed. If you want to change the name, type in a new name or select a name from the Existing Folders list.

8. Click the **Next>** button to proceed. The PC will display the Start Copying Files window.
9. Click the **Next>** button to start the installation.

If the installation is successful, the Setup Complete windows is displayed.

Creating a Desktop Shortcut Icon

Perform the following procedure to create an icon on your PC desktop that you can use to run the Logo Generator application.

1. On your PC display, move the mouse cursor to any unoccupied desktop area, and then click the right mouse button to open the desktop menu.
2. From the desktop menu select **New**, and then select **Shortcut** to open the Create Shortcut dialog box.
3. Click the **Browse...** button in the Create Shortcut dialog box.

4. Use the Browse dialog box to locate the Logo Generator directory.
 - a. If you installed the Logo Generator application using the default directory location and the default folder name in the installation procedure, select the following directory folders in order: **Program Files**, **Tektronix**, **TG700**, and **LogoGen**.
 - b. If you installed the Logo Generator application to a custom location or gave the application folder a custom name, you will need to select your custom directory path.
 - c. You should now be at a location in the PC directory structure where the browse list box shows the **Logogen.exe** file.
5. Select the **Logogen.exe** file (Logogen.exe will be displayed in the file name box), and then click the **Open** button. The directory path to the Logogen.exe file will now be displayed in the Command Line box of the Create Shortcut dialog box.
6. Click the **Next>** button in the Create Shortcut dialog box. The default name of the shortcut icon is now displayed in the dialog box. You can edit the icon name to suit your needs or accept the default name.
7. Click the **Finish** button to finish creating the desktop shortcut icon. The Logogen.exe shortcut icon will now appear on the PC desktop. You can start the Logo Generator application by double-clicking the **Logogen.exe** (or your custom name) shortcut icon.

Starting and Exiting Logo Generator

When you complete the installation procedure, you can use any of the following methods to start the Logo Generator application:

- Double-click the Logogen.exe shortcut icon on the PC desktop that you created during the installation procedure.
- Double-click the Logogen.exe file name in the Program Manager window.
- Select LOGOGEN from the Start - Programs menu.

To exit (quit) the Logo Generator application, select **Exit** from the **File** menu command list of the application.

Elements of the Logo Generator Window

Figure 3-23 shows the Logo Generator application window. Table 3-14 provides a description of the elements in the application window.

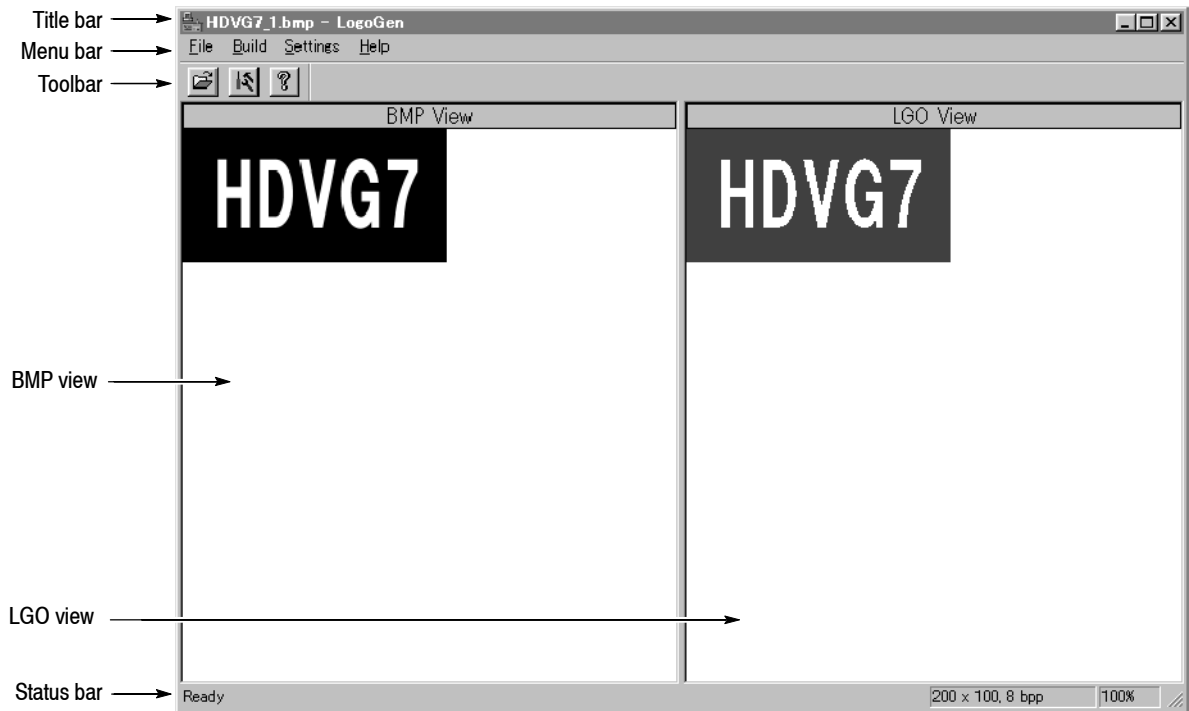





Figure 3-23: Logo Generator application window

Table 3-14: Elements of the Logo Generator window

Element	Description
Title bar	The Title bar displays the name of the application and contains the standard window-sizing boxes for Windows.
Menu bar	The Menu bar displays the names of the four pull-down menus. Refer to <i>Using the Logo Generator Menus</i> on page 3-54 for detailed information about the functions available in the menus.
Toolbar	The Toolbar provides shortcut buttons for many of the most often used menu commands. Click a toolbar button to select the corresponding command. You can toggle the toolbar display on and off using the Toolbar commands in the Settings pull-down menu. Table 3-15 describes the function of each toolbar button.
BMP View	The BMP View displays the selected bitmap image.
LGO View	The LGO View displays the logo image converted to a gray scale.
Status bar	The status bar displays the bitmap size, bits per pixel, and conversion status (%) of the gray scale image.

Table 3-15: Toolbar button descriptions

Icon	Name	Function
	Open	Equivalent to the Open command in the File menu.
	Build Logo File	Equivalent to the Build Logo File command in the Build menu.
	About	Equivalent to the About LogoGen command in the Help menu.

Using the Logo Generator Menus

The Menu bar displays the names of the four pull-down menus: File, Build, Settings, and Help. This section describes the function of each selection in these menus.

File Menu The File menu contains commands for managing file operation and for exiting the Logo Generator application. Table 3-16 describes each of the File menu commands.

Table 3-16: Logo Generator File menu commands

Command	Function
Open	Displays the Open dialog box where you can select the bitmap file you want to convert to a logo file.
Exit	Exits the Logo Generator application.

Build Menu The Build menu contains a command that creates a logo file. Table 3-17 describes the Build menu command.

Table 3-17: Logo Generator Build menu commands

Command	Function
Build Logo File	Create a logo file (.lgo) from a bitmap file (.bmp).

Settings Menu The Settings menu contains commands for setting the gray level and background color for a logo image. Table 3-18 describes each of the Settings menu commands.

Table 3-18: Logo Generator Settings menu commands

Command	Function
Gray Level...	Sets the gray level when a bitmap image is converted to a logo image. When you click this command, the Gray Scale Settings dialog box appears. Refer to <i>Gray Scale Settings Dialog Box</i> on page 3-55 for detailed information about the dialog box parameters.
Miscellaneous...	Sets a logo name, user comment, and display position. When you click this command, the Miscellaneous Settings dialog box appears. Refer to <i>Miscellaneous Settings Dialog Box</i> on page 3-56 for detailed information about the dialog box parameters.
Background	Sets the background color.

Table 3-18: Logo Generator Settings menu commands (Cont.)

Command	Function
Toolbar	Toggles the display of the Toolbar on and off in the application window. A check mark precedes the command in the menu when the Toolbar is selected for display.
Status Bar	Toggles the display of the Status bar on and off in the application window. A check mark precedes the command in the menu when the Status bar is selected for display.
Save Settings	Specifies whether all the settings are saved or not.

Gray Scale Settings Dialog Box. The Gray Scale Settings dialog box (see Figure 3-24) appears after you click the **Gray Level...** command.

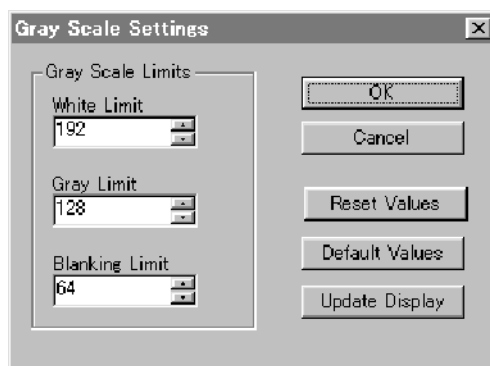
**Figure 3-24: Gray Scale Settings dialog box**

In this dialog box, you can set the following parameters:

- **White Limit:** Sets the maximum level for the Gray 2 level. The gray scale values greater than this value become white level. You can set the value from 0 to 255. The default value is 192.
- **Gray Limit:** Sets the maximum level for the Gray 1 level. You can set the value from 0 to 255. The default value is 128.
- **Blanking Limit:** Sets the maximum level for the Transparent. You can set the value from 0 to 255. The default value is 64.

OK button enables all of the settings in the dialog box and closes the dialog box.

Cancel button cancels all of the settings in the dialog box and closes the dialog box.

Reset Values button resets all of the settings to the values when the dialog box is first displayed.

Default Values button resets all of the settings to their default values.

Update Display button enables all of the settings with the dialog box opened.

Miscellaneous Settings Dialog Box. The Miscellaneous Settings dialog box (see Figure 3-25) appears after you click the **Miscellaneous...** command.

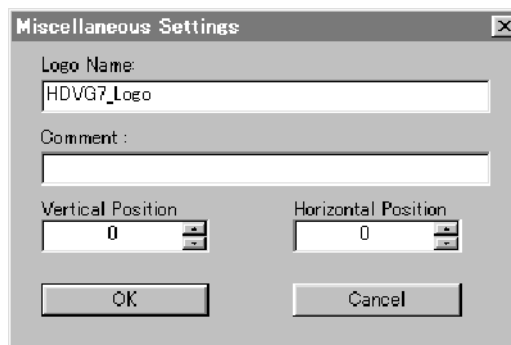

Figure 3- 25: Miscellaneous Settings dialog box

In this dialog box, you can set the following parameters:

- **Logo Name:** Sets the logo name. This logo name is used when you select a logo from the LOGO OVERLAY submenu of the DVG7 or HDVG7 module. The default logo name is the file name.
- **Comment:** Sets the user comment described in the logo file. You need not enter any comments in general use.
- **Vertical Position:** Sets the vertical position where the logo is displayed on the monitor. You can set the value from -100% to 0%. The vertical position can be set from the LOGO OVERLAY submenu of the DVG7 or HDVG7 module.
- **Horizontal Position:** Sets the horizontal position where the logo is displayed on the monitor. You can set the value from -100% to 0%. The horizontal position can be set from the LOGO OVERLAY submenu of the DVG7 or HDVG7 module.

OK button enables all of the settings in the dialog box and closes the dialog box.

Cancel button cancels all of the settings in the dialog box and closes the dialog box.

Help Menu The Help menu contains command that display the version information about the Logo Generator application. Table 3-19 describes the Help menu command.

Table 3-19: Logo Generator Help menu command

Command	Function
About LogoGen...	Displays information including the Logo Generator software version number and copyright information.

Logo Generator Tutorials

This subsection describes the basics of operating the Logo Generator application.

Creating a Logo File Perform the following steps to create a logo file (.lgo) from a Windows bitmap file (.bmp).

1. Select **Open** from the **File** pull-down menu to open the Open dialog box.
2. In the Open dialog box, select the bitmap file on the PC that you want to convert, and then click the **Open** button. This will display the bitmap image in the BMP View and the logo image converted to a gray scale in the LGO View.
3. Select **Gray Level...** from the **Settings** pull-down menu to open the Gray Scale Settings dialog box shown in Figure 3-24 on page 3-55.
4. In the Gray Scale Settings dialog box, set the gray levels for the logo image.

You can change the background color for the logo image using the Background command.

5. Select **Miscellaneous...** from the **Settings** pull-down menu to open the Miscellaneous Settings dialog box shown in Figure 3-25 on page 3-56.
6. In the Miscellaneous Settings dialog box, set the vertical and horizontal positions for the logo to be displayed on the monitor. If necessary, set the logo name and user comment.

7. Select **Build Logo File** from the **Build** pull-down menu to open the BMP to LGO File Conversion dialog box shown in Figure 3-26.



Figure 3-26: BMP to LGO File Conversion dialog box

8. Click the **OK** button to create the logo file.

Using TG7 Setup to Set Parameters

TG7 Setup, a standard accessory with the TG700, is a software application for a PC using the Microsoft Windows system. TG7 Setup provides the capability to set all of the parameters of the TG700 mainframe and installed modules using a PC.

This section provides the following information:

- PC system requirements
- Installation instructions and Ethernet setup
- Starting and exiting TG7 Setup
- Elements of the TG7 Setup window
- Using the TG7 Setup menus
- TG7 Setup tutorial

PC System Requirements

Your PC requires the following minimum system requirements to load and operate the TG7 Setup application:

- Microsoft Windows 95, 98, 2000, or NT4.0 (for Windows 95 or NT 4.0, Internet Explorer 4.01 or later needs to be installed)
- Ethernet interface

Installation Instructions and Ethernet Setup

This subsection provides the following instructions: installing the TG7 Setup application on your PC, creating a desktop shortcut icon on the PC to run TG7 Setup, connecting your PC(s) to the TG700 using the Ethernet port, and setting the required Ethernet parameters.

Installing TG7 Setup

The following installation instructions assume that you are familiar with the basics of using the Windows operating system. If necessary, read your Windows user documentation before installing TG7 Setup.

Perform the following procedure to install TG7 Setup:

1. Be sure that your PC meets the requirements listed under *PC System Requirements* on page 3-59 before proceeding with the installation.
2. Insert the TG700 Signal Generator Platform Software Library CD-ROM into a CD-ROM drive on your PC.
3. Double-click the **My computer** icon and the **CD-ROM drive** icon on the PC desktop. The PC will display the contents of the TG700 Signal Generator Platform Software Library CD-ROM.
4. Double-click the **Tools** folder and the **TG7 Setup** folder on the PC desktop. The PC will display the contents of the TG7 Setup folder.
5. Double-click the **Setup.exe** icon in the folder.

This copies initial files of the TG7 Setup application. For a while, the Welcome window appears on the PC desktop.

6. Read the displayed information, and then click the **Next>** button to proceed with the installation.

The PC will display the Choose Destination Location window. The default directory location for the application is displayed. If you want to install TG7 Setup in a custom location, click the **Browse...** button, and then select or create a custom directory location.

7. Click the **Next>** button to proceed.

The PC will display the Select Program Folder window. The default name for the program folder is displayed. If you want to change the name, type in a new name or select a name from the Existing Folders list.

8. Click the **Next>** button to proceed. The PC will display the Start Copying Files window.
9. Click the **Next>** button to start the installation.

If the installation is successful, the Setup Complete window is displayed.

Creating a Desktop Shortcut Icon

Perform the following procedure to create an icon on your PC desktop that you can use to run the TG7 Setup application.

1. On your PC display, move the mouse cursor to any unoccupied desktop area, and then click the right mouse button to open the desktop menu.
2. From the desktop menu select **New**, and then select **Shortcut** to open the Create Shortcut dialog box.
3. Click the **Browse...** button in the Create Shortcut dialog box.

4. Use the Browse dialog box to locate the TG7 Setup directory.
 - a. If you installed the TG7 Setup application using the default directory location and the default folder name in the installation procedure, select the following directory folders in order: **Program Files**, **Tektronix**, **TG700**, and **TG7 Setup**.
 - b. If you installed the TG7 Setup application to a custom location or gave the application folder a custom name, you will need to select your custom directory path.
 - c. You should now be at a location in the PC directory structure where the browse list box shows the **TG7Setup.exe** file.
5. Select the **TG7Setup.exe** file (TG7Setup.exe will be displayed in the file name box), and then click the **Open** button. The directory path to the TG7Setup.exe file will now be displayed in the Command Line box of the Create Shortcut dialog box.
6. Click the **Next>** button in the Create Shortcut dialog box. The default name of the shortcut icon is now displayed in the dialog box. You can edit the icon name to suit your needs or accept the default name.
7. Click the **Finish** button to finish creating the desktop shortcut icon. The TG7Setup.exe shortcut icon will now appear on the PC desktop. You can start the TG7 Setup application by double-clicking the **TG7Setup.exe** (or your custom name) shortcut icon.

Connecting Your PC(s) to the TG700

TG7 Setup uses the rear-panel 10 BASE-T port on the TG700 to communicate with a PC.

Refer to *Connecting to a Network* on page 3-15 for detailed information about how to connect your PC(s) to the TG700 .

Setting Ethernet Network Parameters

Before you can use TG7 Setup to set the parameters of the TG700 mainframe and installed modules, you must set the Ethernet network parameters for both the TG700 and the TG7 Setup application.

NOTE. Use the *ping* command from the PC to verify network communications after you set the Ethernet network parameters for the TG700 and for the TG7 Setup application.

Ethernet Parameters for the TG700. The Ethernet network parameters for the TG700 can be set using the **NETWORK SETUP** submenu in the **UTILITY** main menu. Refer to *Setting Ethernet Network Parameters* on page 3-16 for detailed information about how to set the network parameters.

Ethernet Parameters for TG7 Setup. When you start the TG7 Setup application, the Ethernet dialog box appears as shown in Figure 3-27. Use this dialog box to set the Ethernet network parameters for the TG7 Setup application.

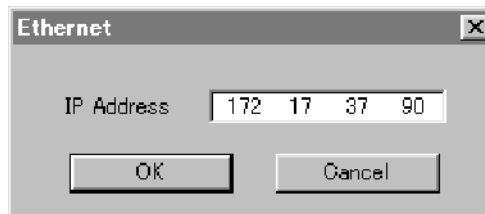

Figure 3-27: Ethernet dialog box for TG7 Setup

Perform the following procedure to set the Ethernet network parameters for the TG7 Setup application:

1. Use the **IP Address** field in the dialog box to enter the IP address that you assigned to the TG700.
2. Click the **OK** button to accept the settings and close the dialog box.

Starting and Exiting TG7 Setup

When you complete the installation procedure, you can use any of the following methods to start the TG7 Setup application:

- Double-click the TG7Setup.exe shortcut icon on the PC desktop that you created during the installation procedure.
- Double-click the TG7Setup.exe file name in the Program Manager window.
- Select TG7Setup from the Start - Programs menu.

To exit (quit) the TG7 Setup application, select **Exit** from the **File** menu command list of the application.

NOTE. When you start the TG7 Setup application, once the application window appears (see Figure 3-28) the TG700 front-panel buttons are disabled.

Elements of the TG7 Setup Window

Figure 3-28 shows the TG7 Setup application window. Table 3-20 provides a description of the elements in the application window.

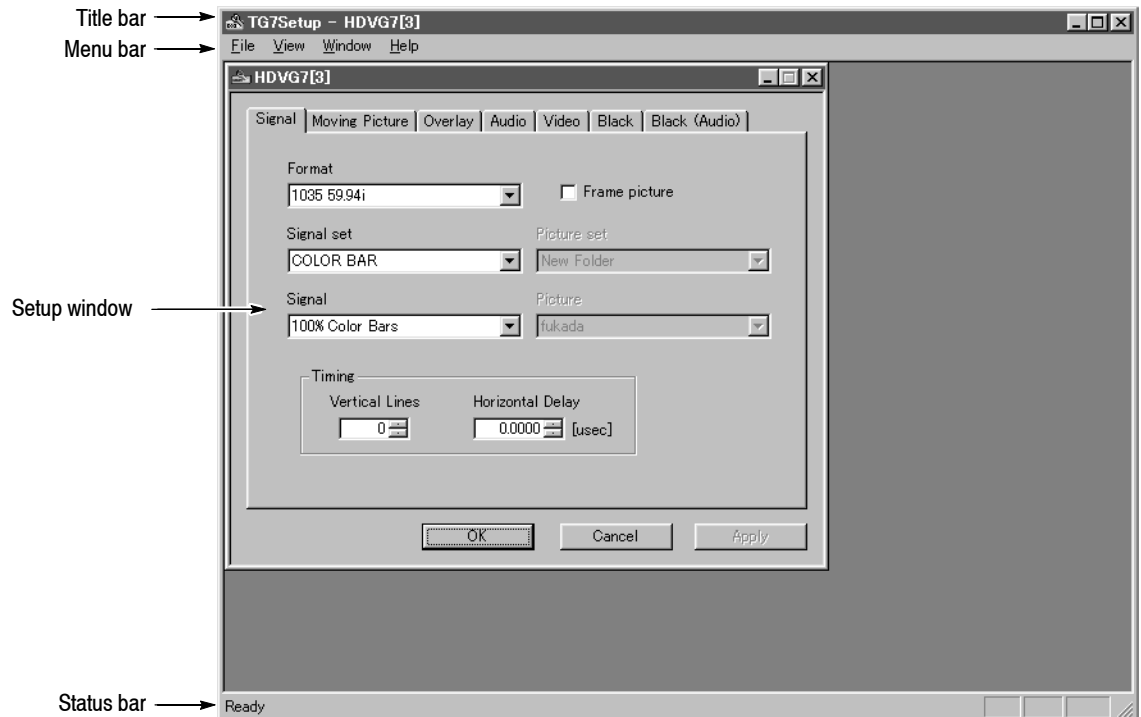

Figure 3-28: TG7 Setup application window

Table 3-20: Elements of the TG7 Setup window

Element	Description
Title bar	The Title bar displays the name of the application and contains the standard window-sizing boxes for Windows.
Menu bar	The Menu bar displays the names of the four pull-down menus. Refer to <i>Using TG7 Setup Menus</i> , below, for detailed information about the functions available in the menus.
Setup window	Use the Setup window to set the parameters for the installed modules or mainframe. This window appears after you select the Open Module or Open TG700 command from the File pull-down menu.
Status bar	The Status bar displays the short explanation of the currently selected command and the information related to the operation.

Using the TG7 Setup Menus

The Menu bar displays the names of the four pull-down menus: File, View, Window, and Help. This section describes the function of each selection in these menus.

File Menu The File menu contains commands for opening a setup window, for managing preset operations, and for exiting the TG7 Setup application. Table 3-21 describes each of the File menu commands.

Table 3-21: TG7 Setup File menu commands

Command	Function
Open TG700	Opens the setup window for the TG700 mainframe.
Open Module	Opens the setup window for the selected module.
Recall Preset	Recalls the selected preset.
Save Preset	Saves the current instrument settings to the selected preset.
Rename Preset	Renames the selected preset name. When you select this command, the Rename dialog box appears. Refer to <i>Rename dialog box</i> on page 3-65 for more information.
Exit	Exits the TG7 Setup application.

Rename Dialog Box. The Rename dialog box (see Figure 3-29) appears after you select the **Rename Preset** command.

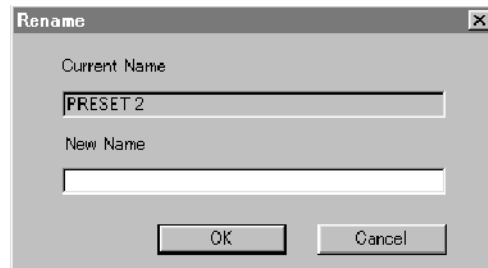

Figure 3-29: Rename dialog box

- **Current Name:** Displays the current preset name.
- **New Name:** Enter the desired preset name in the text box.

OK button enables the new name and close the dialog box.

Cancel button cancels the renaming operation and closes the dialog box.

View Menu The View menu Status Bar command toggles the display of the Status bar on and off in the application window. A check mark precedes the command in the menu when the Status bar is selected for display.

Window Menu The Window menu contains commands that control the appearance of the setup windows in the application window. Table 3-22 describes each of the Window menu commands.

Table 3-22: TG7 Setup Window menu commands

Command	Function
Cascade	Arranges the setup windows so that they overlap one another.
Tile	Arranges the setup windows so that they do not overlap each other.
Arrange Icons	When the setup windows are minimize, arrange their title bars.

Help Menu The Help menu About TG7Setup... command displays information including the TG7 Setup software version number and copyright information.

TG7 Setup Tutorial

After you have connected the TG700 to the PC using an Ethernet cable and set the required network parameters, you can use TG7 Setup to set the parameters for the TG700 mainframe and installed modules.

NOTE. Refer to the *Operating Basics* section of each module's User manual for detailed explanation of the parameters and their setting ranges.

Setting Parameter(s)

This subsection explains how to set the parameter(s) of an installed module. In this example, you will set the parameters for the DVG7 module.

Perform the following steps to set parameter(s):

1. Select **Open Module** and **DVG7** from the **File** pull-down menu to open the setup window for the DVG7 module shown in Figure 3-30.

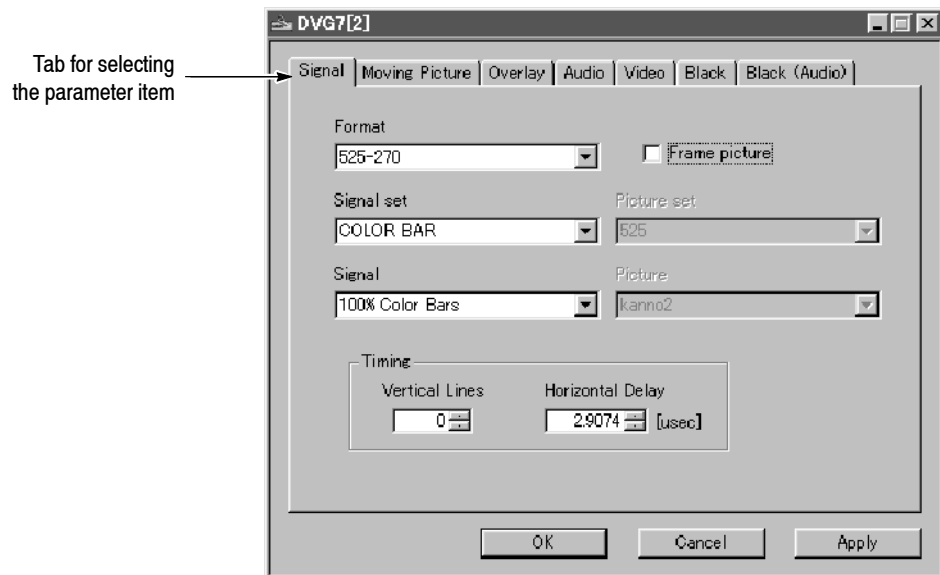

Figure 3-30: Setup window for DVG7 module

At the top of the setup window, there are several tabs to select parameters. When you click one of the tabs, you access the fields associated with that parameter.

In Figure 3-30, the Signal tab is selected and the fields for setting the signal format, signal set, output signal, frame picture, and timing are displayed.

When you change any parameter in the window, the Apply button at the bottom of the window becomes active. Press this button to enable the new parameter setting(s).

2. Click the tab associated with the parameter you want to set. This opens the parameter fields for that tab.
3. Set parameter(s) in the displayed fields.
4. Repeat Steps 2 and 3 until all of the parameter settings are completed.
5. When you finish making changes to the parameters, click the **Apply** button. This enables the parameter settings in the setup window and transfers them to the TG700.

NOTE. *If you select a signal file or a picture file that is not assigned to a test signal button on the TG700 front panel, an error message appears when you click the Apply button. If this happens, you need to assign the file to a test signal button. Refer to SIGNAL KEY ASSIGN Submenu on page 3-9 for more information.*

When you change parameter(s) for a module that module is selected in the TG700, regardless of what is shown on the display. To prevent addressing the wrong module from the front panel after you exit TG7 Setup, first select any of the modules using the MODULE button and then make settings.

Using the File Copy Tools

The file copy tools; TG7 Backup, TG7 Restore, and TG7 Duplicator, standard accessories with the TG700, are software applications for a PC using the Microsoft Windows system. TG7 Backup and TG7 Restore provide the capability to backup and restore preset files between a PC and the TG700 using the Ethernet interface. TG7 Duplicator provides the capability to transfer all of the files between two TG700 Generators, using the Ethernet interface.

This section provides the following information:

- PC system requirements
- Installation instructions and Ethernet setup
- Starting and exiting the file copy tools
- File copy tools tutorials

PC System Requirements

Your PC requires the following minimum system requirements to load and operate the file copy tools:

- Microsoft Windows 2000/XP
- Ethernet interface

Installation Instructions and Ethernet Setup

This subsection provides the following instructions: installing the file copy tools on your PC, creating a desktop shortcut icon on the PC to run the file copy tools, and connecting your PC(s) to the TG700 using the Ethernet port.

Installing the File Copy Tools

The following installation instructions assume that you are familiar with the basics of using the Windows operating system. If necessary, read your Windows user documentation before installing the file copy tools.

Perform the following procedure to install the file copy tools:

1. Be sure that your PC meets the requirements listed under *PC System Requirements*, above, before proceeding with the installation.
2. Insert the **TG700 Signal Generator Platform Software Library** CD-ROM into a CD-ROM drive on your PC.

3. Double-click the **My computer** icon and the **CD-ROM drive** icon on the PC desktop. The PC will display the contents of the TG700 Signal Generator Platform Software Library CD-ROM.
4. Double-click the **Tools** folder and **TG700 File Copy Tools** folder on the PC desktop. The PC will display the contents of the TG700 File Copy Tools folder.
5. Double-click the **Setup.exe** icon in the folder.

This copies initial files of the file copy tools. For a while, the Welcome window appears on the PC desktop.

6. Read the displayed information, and then click the **Next>** button to proceed with the installation.

The PC will display the Choose Destination Location window. The default directory location for the applications is displayed. If you want to install the file copy tools in a custom location, click the **Browse...** button, and then select or create a custom directory location.

7. Click the **Next>** button to proceed.

The PC will display the Select Program Folder window. The default name for the program folder is displayed. If you want to change the name, type in a new name or select a name from the Existing Folders list.

8. Click the **Next>** button to proceed. The PC will display the Start Copying Files window.
9. Click the **Next>** button to start the installation.

If the installation is successful, the Setup Complete windows is displayed.

Creating a Desktop Shortcut Icon

Perform the following procedure to create icons on your PC desktop that you can use to run the file copy tools; TG7 Backup, TG7 Restore, and TG7 Duplicator.

1. On your PC display, move the mouse cursor to any unoccupied desktop area, and then click the right mouse button to open the desktop menu.
2. From the desktop menu select **New**, and then select **Shortcut** to open the Create Shortcut dialog box.
3. Click the **Browse...** button in the Create Shortcut dialog box.

4. Use the Browse dialog box to locate the Logo Generator directory.
 - a. If you installed the file copy tools using the default directory location and the default folder name in the installation procedure, select the following directory folders in order: **Program Files**, **Tektronix**, **Tg7**, and **File Copy Tools**.
 - b. If you installed the file copy tools to a custom location or gave the application folder a custom name, you will need to select your custom directory path.
 - c. You should now be at a location in the PC directory structure where the browse list box shows the **TG7Backup.exe**, **TG7Duplicator.exe**, and **TG7Restore.exe** files.
5. Select the **TG7Backup.exe**, **TG7Duplicator.exe**, or **TG7Restore.exe** file and then click the **Open** button. The directory path to the selected file will now be displayed in the Command Line box of the Create Shortcut dialog box.
6. Click the **Next>** button in the Create Shortcut dialog box. The default name of the shortcut icon is now displayed in the dialog box. You can edit the icon name to suit your needs or accept the default name.
7. Click the **Finish** button to finish creating the desktop shortcut icon. The selected shortcut icon will now appear on the PC desktop. Repeat Steps 1 to 6 to create the desktop shortcut icons for the other applications.

You can start any of the application by double-clicking the corresponding (or your custom name) shortcut icon.

Connecting Your PC(s) to the TG700

TG7 Backup, TG7 Restore, and TG7 Duplicator use the rear-panel 10 BASE-T port on the TG700 to communicate with a PC or another TG700.

Refer to *Connecting to a Network* on page 3-15 for detailed information about how to connect your PC(s) to the TG700.

Setting Ethernet Network Parameters

Before you can use the TG7 Backup, TG7 Restore, or TG7 Duplicator to transfer files between the TG700 and your PC(s) or between two TG700 Generators, you must first set the Ethernet network parameters for the TG700.

NOTE. Use the *ping* command from the PC to verify network communications after you set the Ethernet network parameters for the TG700 and for the TG7 Backup or TG7 Restore application.

Ethernet Parameters for the TG700. The Ethernet network parameters for the TG700 can be set using the **NETWORK SETUP** submenu in the **UTILITY** main menu. Refer to *Setting Ethernet Network Parameters* on page 3-16 for detailed information about how to set the network parameters.

Starting and Exiting the File Copy Tools

When you complete the installation procedure, you can use any of the following methods to start the file copy tools:

- Double-click the TG7Backup.exe, TG7 Dupli.exe, or TG7Restore.exe shortcut icon on the PC desktop that you created during the installation procedure.
- Double-click the TG7Backup.exe, TG7Dupli.exe, or TG7Restore.exe file name in the Program Manager window.
- Select TG7Backup, TG7Dupli, or TG7Restore from the Start - Programs menu.

To exit (quit) the TG7 Backup, TG7 Duplicator, or TG7 Restore application, select **Exit** from the **File** menu command list of the application.

File Copy Tools Tutorials

This subsection describes the basics of operating the TG7 Backup, TG7 Restore, and TG7 Duplicator applications.

Backing up Preset Files by TG7 Backup

The TG7 Backup application allow you to backup all of the preset files saved in the TG700 to your PC.

About a Preset File.

A preset file is a file saved in the **PRESET** folders of all of the installed modules and has the following format:

MSTATE<slot_number>.P<preset_number>

For example, MSTATE1.P01 is the preset for the module installed in slot 1 of the TG700, with preset number 1.

All of the folders and files in the TG700 file system are displayed using the TG7 Comm application. Refer to *Using TG7 Comm for File Transfers* on page 3-27 for detailed information about the TG7 Comm application.

Backup Procedure. Perform the following steps to backup all of the preset files from the TG700 to the PC:

1. Start the TG7 Backup application to open the TG7 Backup window shown in Figure 3-31.

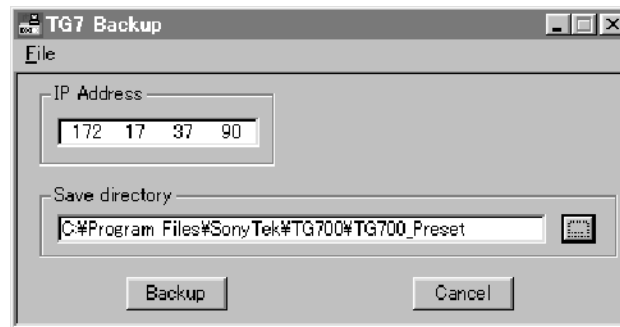

Figure 3-31: TG7 Backup window

2. Use the **IP Address** field in the window to enter the IP address of the TG700.
3. Use the **Save directory** field in the dialog box to specify the destination folder for the preset files you are going to backup to your PC.
4. Click the **Backup** button to start the backup operation.

When the backup operation is complete, the dialog box appears as shown in Figure 3-32.

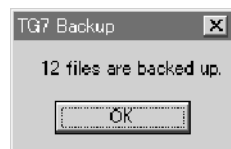

Figure 3-32: Dialog box shows backup is complete

5. Click the **OK** button.

Restoring Preset Files with TG7 Restore

The TG7 Restore application allows you to restore all of the preset files saved in the PC to the TG700.

NOTE. To restore the all of the preset files to the TG700 and reuse them, the hardware configuration of the TG700 must be the same hardware configuration as when the preset files were backed up.

Perform the following steps to restore all of the preset files from the PC to the TG700:

1. Start the TG7 Restore application to open the TG7 Restore window shown in Figure 3-33.

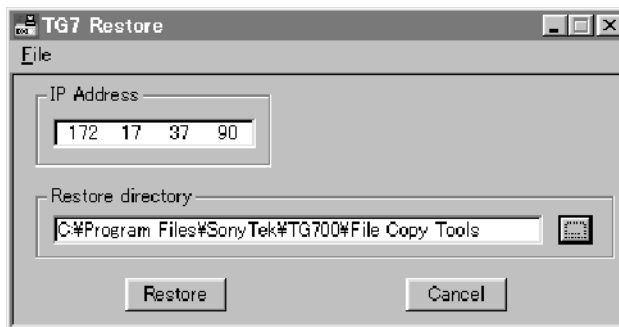

Figure 3-33: TG7 Restore window

2. Use the **IP Address** field in the window to enter the IP address of the TG700.
3. Use the **Restore directory** field in the dialog box to specify the folder in which the preset files are saved.
4. Click the **Restore** button to start the restore operation.

When the restore operation is complete, the dialog box appears as shown in Figure 3-34.



Figure 3-34: Dialog box shows restore is complete

5. Click the **OK** button.

Transferring Files by TG7 Duplicator

The TG7 Duplicator application allows you to transfer all of the files in one TG700 to another TG700.

NOTE. To transfer files between the two TG700 using the TG7 Duplication application, both of the instruments need to be the same memory size.

Perform the following steps to transfer all of the files in one TG700 to another TG700:

1. Start the TG7 Duplicator application to open the TG7 Duplicator window shown in Figure 3-35.

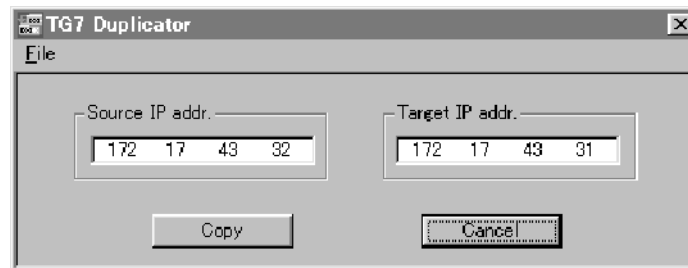

Figure 3-35: TG7 Duplicator window

2. Use the **Source IP addr.** field in the window to enter the IP address of the source instrument.
3. Use the **Target IP addr.** field in the window to enter the IP address of the target instrument.
4. Click the **Copy** button to start the file transfer operation.

The progress gauge appears to show that file transfer is progressing.



CAUTION. Do not power off either of the TG700's until file transfer is complete. Doing so will cause both instruments to not start up normally.

When the file transfer is complete, the dialog box appears as shown in Figure 3-36.



Figure 3-36: Dialog box shows file transfer is complete

5. Click the **OK** button.

Syntax

This section contains information on the Standard Commands for Programmable Instruments (SCPI) and IEEE 488.2 Common Commands you can use to program your TG700. The information is organized in the following subsections:

- *Programming Model* - This subsection provides information on programming prerequisites
- *SCPI Commands and Queries* - This subsection describes the SCPI command organization and syntax
- *IEEE 488.2 Common Commands* - This subsection lists the commands and argument structures that are common to all SCPI commands
- *Constructed Mnemonics* - This subsection describes the usage of constructed mnemonics by the TG700.
- *Block Arguments* - This subsection describes the usage of block arguments by the TG700.
- *Special Characters* - This subsection lists the special character sets that are used by the remote control interface.

Programming Model

Specific conditions must exist before programming commands will affect the test signal generated by a module.

Addressing Module Test Signals

Select the module to be addressed before executing any commands. Many of the commands used by the TG700 are shared by several modules and will be accepted without a reported error.

Command Arguments

Many commands accept either string or numeric arguments. For example: a boolean argument can either be “1” or “ON”.

Select signal parameter commands accept either a numeric value or one of the following strings:

MINimum. Use this argument to query the minimum value or set the parameter value to the minimum acceptable value.

MAXimum. Use this argument to query the maximum value or set the parameter value to the maximum acceptable value.

DEFault. Use this argument to query the default value or set the parameter value to the default value.

UP. Use this argument to increase the parameter value one increment as defined by the :STEP value.

DOWN. Use this argument to decrease the parameter value one increment as defined by the :STEP value.

NOTE. *If the TG700 does not return a value in response to a MIN or MAX query, then the values are undefined and an error message is generated.*

Argument Example

The following example demonstrates the effect of each of the arguments when used with a step value.

1. `:INSTrument:SElect "HDVG7:#"` selects the HDTV digital video generator module located in the slot number indicated by the “#” symbol.
2. `:OUTPut:CIRClE:STATe ON` displays a circle on the video display.

NOTE. `:OUTPut:CIRClE:DIAMeter` uses an argument that is the percent of picture height.

3. `:OUTPut:CIRClE:DIAMeter DEFault` sets the circle diameter to 90 percent of the screen height.
4. `:OUTPut:CIRClE:DIAMeter:STEP 10` sets the step increment to 10 percent.
5. `:OUTPut:CIRClE:DIAMeter DOWN` changes the circle diameter to 80 percent of the screen height.
6. `:OUTPut:CIRClE:DIAMeter 50` changes the circle diameter to 50 percent of the screen height.
7. `:OUTPut:CIRClE:DIAMeter MAXimum` changes the circle diameter to 100 percent of the screen height.
8. `:OUTPut:CIRClE:DIAMeter MINimum` changes the circle diameter to 0 percent of the screen height.
9. `:OUTPut:CIRClE:DIAMeter UP` changes the circle diameter to 10 percent of the screen height.
10. `:OUTPut:CIRClE:DIAMeter? MAXimum` queries the maximum circle diameter (not the current diameter). The query returns the value of 100 percent, which is the maximum circle diameter allowable.

SCPI Commands and Queries

SCPI is a standard created by a consortium that provides guidelines for remote programming of instruments. These guidelines provide a consistent programming environment for instrument control and data transfer. This environment uses defined programming messages, instrument responses, and data format across all SCPI instruments, regardless of manufacturer. The TG700 uses a command language based on the SCPI standard.

The SCPI language is based on a hierarchical or tree structure (see Figure 3-37) that represents a subsystem. The top level of the tree is the root node; it is followed by one or more lower-level nodes.

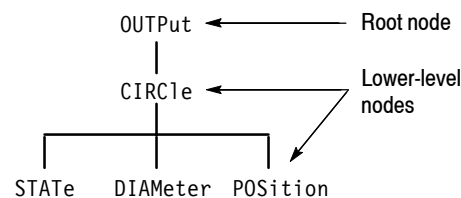

Figure 3-37: Example of SCPI subsystem hierarchy tree

You can create commands and queries from these subsystem hierarchy trees. Commands specify actions for the instrument to perform. Queries return measurement data and information about parameter settings.

Creating Commands

SCPI commands are created by stringing together the nodes of a subsystem hierarchy and separating each node by a colon.

In Figure 3-37, `OUTPut` is the root node and `CIRClE`, `STATe`, `DIAMeter`, and `POSition` are lower-level nodes. To create a SCPI command, start with the root node `OUTPut` and move down the tree structure adding nodes until you reach the end of a branch. Most commands and some queries have parameters; you must include a value for these parameters. If you specify a parameter value that is out of range, the parameter will be set to a default value.

For example, `OUTPut:CIRClE:STATe ON` is a valid SCPI command created from the hierarchy tree in Figure 3-37.

Creating Queries

To create a query, start at the root node of a tree structure, move down to the end of a branch, and add a question mark. `OUTPut:CIRClE:STATe?` is an example of a valid SCPI query using the hierarchy tree in Figure 3-37.

Parameter Types

Every parameter in the command and query descriptions is of a specified type. The parameters are enclosed in brackets, such as <pattern>. The parameter type is listed after the parameter and is enclosed in parentheses, for example, (discrete). Some parameter types are defined specifically for the TG700 command set and some are defined by ANSI/IEEE 488.2-1987 (see Table 3-23).

Table 3-23: Parameter types used in syntax descriptions

Parameter Type	Description	Example
binary	Binary numbers	#B0110
arbitrary block ¹	A specified length of arbitrary data	#512234xxxxx . . . where 5 indicates that the following 5 digits (12234) specify the length of the data in bytes; xxxxx ... indicates the data
boolean	Boolean numbers or values	ON or 1 OFF or 0
discrete	A list of specific values	MIN, MAX, UP, DOWN
hexadecimal ²	Hexadecimal numbers (0-9, A, B, C, D, E, F)	#HAA, #H1
NR1 ^{2,3} numeric	Integers	0, 1, 15, -1
NR2 ² numeric	Decimal numbers	1.2, 3.141516, -6.5
NR3 ² numeric	Floating point numbers	3.1415E-9, -16.1E5
NRf ² numeric	Flexible decimal number that may be type NR1, NR2 or NR3	See NR1, NR2, NR3 examples
string ⁴	Alphanumeric characters (must be within quotation marks)	"Testing 1, 2, 3"

¹ Defined in ANSI/IEEE 488.2 as "Definite Length Arbitrary Block Response Data."

² An ANSI/IEEE 488.2- 1992-defined parameter type.

³ Some commands and queries will accept a hexadecimal value even though the parameter type is defined as NR1.

⁴ Defined in ANSI/IEEE 488.2 as "String Response Data."

**Abbreviating Commands,
Queries, and Parameters**

You can abbreviate most SCPI commands, queries, and parameters to an accepted short form. This manual shows these short forms as a combination of upper and lower case letters. The upper case letters indicate the accepted short form of a command. As shown in Figure 3-38, you can create a short form by using only the upper case letters. The accepted short form and the long form are equivalent and request the same action of the instrument.

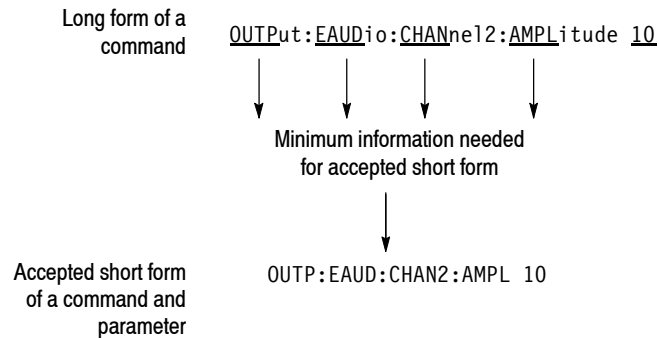

Figure 3-38: Example of abbreviating a command

NOTE. The numeric suffix of a command or query may be included in either the long form or short form; the TG700 will default to “1” if no suffix is used. In Figure 3-38, the “2” of “CHAN2” indicates that the command is directed to the second channel..

Chaining Commands and Queries

You can chain several commands or queries together into a single message. To create a chained message, first create a command or query, add a semicolon (;), and then add more commands or queries and semicolons until you are done. If the command following a semicolon is a root node, precede it with a colon (:). Figure 3-39 illustrates a chained message consisting of several commands and queries. The single chained message should end in a command or query, not a semicolon. Responses to any queries in your message are separated by semicolons.

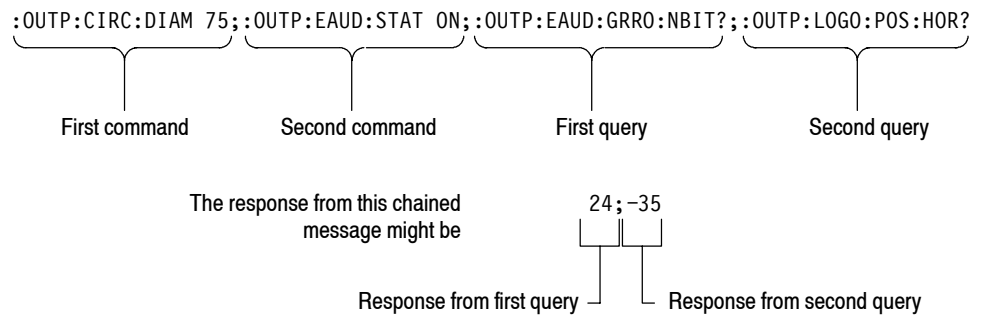

Figure 3-39: Example of chaining commands and queries

If a command has the same root and lower-level nodes as the previous command, you can omit these nodes. In Figure 3-40, the second command has the same root node (CIRC) as the first command, so these nodes can be omitted.

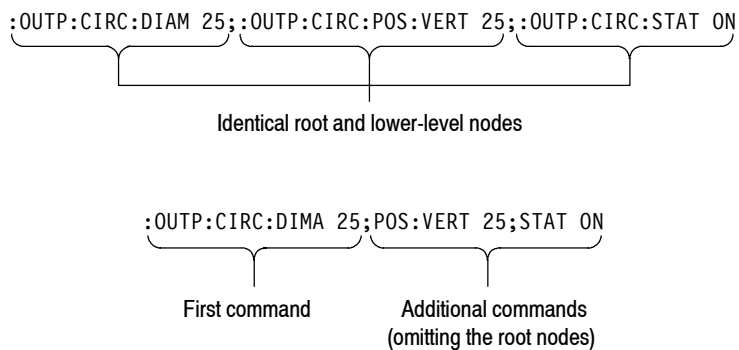

Figure 3-40: Example of omitting root and lower-level nodes in a chained message

General Rules

Here are three general rules for using SCPI commands, queries, and parameters:

- You can use single (' ') or double (" ") quotation marks for quoted strings, but you cannot use both types of quotation marks for the same string.

correct: "This string uses quotation marks correctly."

correct: 'This string also uses quotation marks correctly.'

incorrect: "This string does not use quotation marks correctly.'

- You can use upper case, lower case, or a mixture of both cases for all commands, queries, and parameters.

OUTPUT:TEXT:POSITION:HORIZONTAL 25

is the same as

output:text:position:horizontal 25

and

OUTPUT:text:position:HORIZONTAL 25

NOTE. *Literal strings (quoted) are case sensitive. For example: file names.*

- No embedded spaces are allowed between or within nodes.

correct: OUTPUT:TEXT:POSITION:HORIZONTAL 25

incorrect: OUTPUT: TEXT: POSITION: HOR IZONTAL 25

IEEE 488.2 Common Commands

Description ANSI/IEEE Standard 488.2 defines the codes, formats, protocols, and usage of common commands and queries used on the interface between the controller and the instruments. The TG700 complies with this standard.

Command and Query Structure The syntax for an IEEE 488.2 common command is an asterisk (*) followed by a command and, optionally, a space and parameter value. The syntax for an IEEE 488.2 common query is an asterisk (*) followed by a query and a question mark. All of the common commands and queries are listed in the last part of the *Syntax and Commands* section. The following are examples of common commands:

- *ESE 16
- *CLS

The following are examples of common queries:

- *ESR?
- *IDN?

Backus-Naur Form Definition This manual may describe commands and queries using the Backus-Naur Form (BNF) notation. Table 3-24 defines the standard BNF symbols:

Table 3-24: BNF symbols and meanings

Symbol	Meaning
< >	Defined element
::=	Is defined as
	Exclusive OR
{ }	Group; one element is required
[]	Optional; can be omitted
. . .	Previous element(s) may be repeated
()	Comment

Message Terminators This manual uses <EOM> (End of message) to represent a message terminator.

Symbol	Meaning
<EOM>	Message terminator

The end-of-message terminator may be the ASCII code for line feed (LF) sent as the last data byte. The TG700 always terminates messages with LF. It allows white space before the terminator.

Constructed Mnemonics

Some header mnemonics specify one of a range of mnemonics. For example, an audio channel mnemonic can be either CHANnel1, CHANnel2, CHANnel3, or CHANnel4. You use these mnemonics in the command just as you do any other mnemonic. For example, there is a :OUTP:EAUD:CHAN1:STAT? query, and there is also an :OUTP:EAUD:CHAN2:STAT? query. In the command descriptions, this list of choices is abbreviated as CHANnel<n>. The value of <n> is the upper range of valid suffixes. If the numeric suffix is omitted, the TG700 uses the default value of “1”.

Block Arguments

Several TG700 commands use a block argument form:

Symbol	Meaning
<NZDig>	A non-zero digit character, in the range 1-9
<Dig>	A digit character, in the range 0-9
<DChar>	A character with the hex equivalent of 00 through FF hexadecimal (0 through 255 decimal)
<Block>	A block of data bytes, defined as: <pre><Block> ::= { #<NZDig><Dig>[<Dig>...] [<DChar>...] #0[<DChar>...]<terminator> }</pre>

<NZDig> specifies the number of <Dig> elements that follow. Taken together, the <Dig> elements form a decimal integer that specifies how many <DChar> elements follow.

Special Characters

The remote control interface handles characters differently than the front panel or SDP2000 software.

Standard symbol (ASCII)	Remote control sequence
/ (47)	's
\ (92)	'b
- (45)	'h
' (96)	"
: (58)	'c
Line return	^ (94)

Signal names created from SDP2000 software will be displayed as created. Signals created or displayed using the SCPI interface use the remote control sequence.

For example: "SinX/X" is displayed as "SinX/X" via the front panel or SDP2000 software; however, "SinX/X" is displayed as "SinX'sX" via when using SCPI.

Use the caret symbol "^" as a line return when naming buttons and signals.

Remote Commands

This section describes the remote command set used in the TG700. The commands for the TG700 are divided into the following eight groups:

- Common commands
- DISPLAY commands
- INSTRUMENT commands
- MASS MEMORY commands
- PROGRAM commands
- SENSE commands
- STATUS commands
- SYSTEM commands

The TG700 can be controlled remotely through the Ethernet interface on the rear panel. Refer to *Connecting to a Network* on page 3–15 for detailed information about how to connect and set up for remote operation.

Common Commands

The Common commands have a “*” prefix and address all of the installed modules.

Command Tree

- *CLS
- *ESE(?)
- *ESR?
- *IDN?
- *OPC(?)
- *OPT?
- *RST
- *SRE(?)
- *STB?
- *TST?
- *WAI

Command Description

*CLS

Clears SESR (Standard Event Status Register), the SBR (Status Byte Register), and Event Queue, which are used in the instrument status and event reporting system.

*ESE

Sets the bits of the ESER (Event Status Enable Register) used in the status and events reporting system.

*ESE?

Returns the contents of the ESER.

*ESR?

Returns the contents of SESR (Standard Event Status Register) used in the status and events reporting system.

*IDN?

Returns the ID information of the instrument.

*OPC

Causes bit 0 in the SESR (Standard Event Status Register) to be set , and the operation complete message to be issued, when all pending operations are finished.

*OPC?

Waits until all pending operations are finished and returns a “1 ” ASCII character.

*OPT?

Lists all of the occupied slots in the TG700 and the nomenclature, slot, hardware version, and software version of the installed modules.

Each field is a slot. Each field is separated by commas. The information within a field is colon delimited, as in “<nomenclature>:<slot>:<hw>:<sw>”.

*RST

Resets the instrument to the default state.

*SRE

Sets the bits of the SRER (Service Request Enable Register).

*SRE?

Returns the contents of SRER.

*STB?

Returns the value of the SBR (Status Byte Register). Bit 6 of the SBR is read as a MSS (Master Status Summary) bit.

*TST?

Self-test query. This query does not perform any tests; however, this query is accepted as a valid command to comply with IEEE 488.2 requirements.

*WAI

Wait-to-continue command. This command is not necessary since the TG700 handles commands sequentially; however, this query is accepted as a valid command to comply with IEEE 488.2 requirements.

DISPLAY Commands

Use these commands to control the contrast and backlight settings of the LCD display.

Command Tree

```

:DISPlay
  :BACKlight          ON|OFF
  :CONTRast           <numeric_value>
  [:WINDow] [:TEXT] [:DATA] <message>

```

Command Description

:DISPlay:BACKlight ON|OFF

Turns the LCD display backlight on or off. You can use 1 or 0 instead of ON or OFF.

:DISPlay:BACKlight?

Returns the current status of the backlight.

:DISPlay:CONTrast <numeric_value>

Controls the intensity of the front-panel LCD display. The value should be an integer number between 1 and 40.

:DISPlay:CONTrast?

Returns the current contrast value.

INSTRUMENT Commands

Use these commands to list, identify, and query modules.

Command Tree

```
:INSTRument
  :CATalog?
  :FULL?
  [:SElect] <module_name>
  :NSElect <slot_number>
```

Command Description

:INSTRument:CATalog?

Returns a comma delimited list of all slots that are occupied by modules.

:INSTRument:CATalog:FULL?

Returns a comma delimited list of module names and slot numbers, in pairs. The string type of module and the numeric suffix indicates the slot. For example, "AGL7:1", 1, "HDVG7:2", 2 indicates a AGL7 in slot 1, and a HDVG7 in slot 2.

:INSTRument:[:SElect] <module_name>

Selects a module by name.

:INSTRument:[:SElect]?

Returns a module by name.

:INSTRument:NSElect <slot_number>

Select a module by slot number.

:INSTrument:NSElect?

Returns a module by slot number.

MASS MEMORY Commands

All signal movement within the memory is accomplished by copying all appropriate files of the named signal(s) to the new location. The signal tree is traversable and the use of wildcards permits copying or storing individual signals or the entire module signal list.

Command Tree

```

:MMEMory
  :CATalog?           [<directory_path>]
  :CDIRectory        <directory_path>
  :COPY              <source>,<destination>
  :DATA              <file_name>,<block_data>
  :DElete            <file_name>
  :LOAD
    :DOWNload        <block_data>
    :PRESet           <preset_ID>|<preset_name>
    :SIGNal           <module_name>,<signal_name>
  :MDIRectory        <directory_path>
  :MOVE              <from_filename>,<to_filename>
  :RDIRectory        <directory_path>
  :SIGNal
    :ACTive?         <signal_name>
  :STORE
    :PRESet           <preset_ID>|<preset_name>
  :PRESet
    :CATalog?        <preset_ID>
    :ALL?
    :DElete           <preset_ID>|<preset_name>
    :REName           <preset_ID>,<preset_name>

```

The argument <signal_name> is the full or partial path name to a signal found in a module. The argument <file_name> is the MS-DOS compatible naming convention. For example, the syntax for a complete path would be:

module_type/signal_set/button/test_signal

- module_type is the directory level for a given module type
- signal_set is the directory level for different sets of signals
- button is the directory level for different buttons
- test_signal is the directory level for different test signals

Command Description

:MMEMory:CATalog? [<directory_path>]

Lists the current directory level. If at the top level, it returns a list of signal sets and the other files and directories for the module partition you are currently in. If in a Signal Set directory, it returns a list of buttons. If in a button directory, it returns a list of test signals.

Query response - <used_bytes>, <available_bytes>, <file_name1>,, <file_size1>, <file_name2>,, <file_size2>

:MMEMory:CDIRectory [<directory_path>]

Changes the current working directory.

:MMEMory:CDIRectory?

Returns the current working directory path.

:MMEMory:COPY <source>,<destination>

Copies a file within the TG700 file system. Wildcards are not supported.

This command is provided to support sequence files and is not recommended for use with signal files.

:MMEMory:DATA <file_name>,<block_data>

Loads data created by a PC to the flash memory of the TG700 with the specified file name. The file name should have an appropriate extension.

:MMEMory:DATA? <file_name>

Lists the block data for the specified file name.

:MMEMory:DELeTe <file_name>

Removes files from the flash memory of the TG700.

:MMEMory:LOAD:DOWNload <block_data>

Adds DNL files to the TG700.

:MMEMory:LOAD:PREset <preset_ID>|<preset_name>

Loads a saved preset. This command accepts the name of a previously saved preset. Current instrument settings are overwritten by this command. The preset_IDs are from 0 to 15; 0 represents the Power on Default, 1 to 13 represent ordinary presets, 14 represents the User Default, and 15 represents the Factory Default.

:MMEMory:LOAD:SIGNa1 <module_name>,<signal_name>

:MMEMory:LOAD:SIGNa1 <slot_number>,<signal_name>

Loads the named signal into the named module. The current signal in the module is overwritten.

:MMEMory:MDIRectory <directory_name>

Creates a directory by the given name.

:MMEMory:MOVE <from_filename>,<to_filename>

Changes the name of the specified file.

:MMEMory:RDIRectory <directory_name>

Removes the specified directory from the file system.

:MMEMory:SIGNa1:ACTive? <slot_number>|<module_name>

Lists the current output signal in the specified module.

:MMEMory:STORE:PRESet <preset_ID>|<preset_name>

Saves all the instrument settings with the specified preset ID or preset name. The preset_IDs are from 0 to 15; 0 represents the Power on Default, 1 to 13 represent ordinary presets, 14 represents the User Default, and 15 represents the Factory Default.

:MMEMory:PRESet:CATalog? <preset_ID>

Lists the name of the specified preset saved in the TG700. The preset_IDs are from 0 to 15; 0 represents the Power on Default, 1 to 13 represent ordinary presets, 14 represents the User Default, and 15 represents the Factory Default.

:MMEMory:PRESet:CATalog:ALL?

Lists the names of all presets saved in the TG700.

:MMEMory:PRESet:DELeTe <preset_ID>|<preset_name>

Deletes the specified preset saved in the TG700. The preset_IDs are from 0 to 15; 0 represents the Power on Default, 1 to 13 represent ordinary presets, 14 represents the User Default, and 15 represents the Factory Default.

:MMEMory:PRESet:REName <preset_ID>,<preset_name>

Renames the specified preset saved in the TG700. The preset_IDs are from 0 to 15; 0 represents the Power on Default, 1 to 13 represent ordinary presets, 14 represents the User Default, and 15 represents the Factory Default.

PROGRAM Commands

Use these commands to access and run programs called “sequences”.

Command Tree

```
:PROGram
  [:SElected]?
    :NAME          <programe>
    :STATe         RUN|PAUSE|STOP|CONTinue
    :WAIT?
  :EXPLicit
    :STATe         <programe>, RUN|PAUSE|STOP|CONTinue
    :WAIT?
```

Command Description

:PROGram[:SElected]:NAME <program>

Selects the default sequence file.

:PROGram[:SElected]:NAME?

Returns the name of the default sequence file.

:PROGram[:SElected]:STATe RUN|PAUSE|STOP|CONTinue

Controls execution of the default sequence. The choices are Run, PAUSE, STOP, and CONTINUE.

:PROGram[:SElected]:STATe?

Returns the condition of the execution of the default sequence.

:PROGram[:SElected]:WAIT

Holds off further commands until the default sequence completes.

:PROGram[:SElected]:WAIT?

If sequence has terminated or paused, this returns 1. If sequence is running, this returns 0.

:PROGram:EXPLicit:STATe <programe> RUN|PAUSE|STOP|CONTinue

Controls execution of the specified sequence. The choices are RUN, PAUSE, STOP, and CONTINUE.

:PROGram:EXPLicit:STATe? <programe>

Returns the condition of the execution of the specified sequence.

:PROGram:EXPLicit:WAIT <programe>

Holds off further commands until the specified sequence completes.

:PROGram:EXPLicit:WAIT? <programe>

If sequence has terminated or paused, this returns 1. If sequence is running, this returns 0.

SENSE Commands

Use these queries to list which generator modules are using which frame reset signals.

Command Tree

```
:SENSe
  :ROSCillator
    :FRAMe[3]
      :CATalog?
      :FREQuency?
```

Command Description

:SENSe:ROSCillator:FRAMe<n>:CATalog?

Lists the modules using the frame reset signal <n>. The suffix identifies which of three frame reset signals to query.

:SENSe:ROSCillator:FRAMe<n>:FREQuency?

Lists the specific frame reset signal frequency.

STATUS Commands

Use these commands to address the instrument status and event queue.

Command Tree

```
:STATus
  :OPERation
    [:EVENT]?
    :CONDition?
    :ENABle <numeric_value>
    :PTRansition <numeric_value>
    :NTRansition <numeric_value>
    :MAP <numeric_value>, <numeric_value>
  :INSTrument
    [:EVENT]?
    :CONDition?
    :ENABle <numeric_value>
    :PTRansition <numeric_value>
    :NTRansition <numeric_value>
  :PRESet
  :QUEue
    [:NEXT]
    :ENABle
  :QUESTionable
    [:EVENT]?
    :CONDition?
    :ENABle <numeric_value>
    :PTRansition <numeric_value>
    :NTRansition <numeric_value>
    :MAP <numeric_value>, <numeric_value>
  :INSTrument
    [:EVENT]?
    :CONDition?
    :ENABle <numeric_value>
    :PTRansition <numeric_value>
    :NTRansition <numeric_value>
```

Command Description

PRESet. The OPERation node covers areas of instrument operational events. This node reports such items as signal settling, calibration, or running a sequence

QUESTionable. The QUESTionable node covers areas of questionable conditions that exist within the instrument. Questionable conditions might cause you to be unsure of the quality of the generated signals.

Subnodes. Each node has a set of subnodes that query the contents, or control the involvement, of each bit.

- **ENABLE** selects which bits are active in reporting the status.
- **EVENT** is a destructive query only of the status.
- **CONDition** is a nondestructive query only of the status.
- **PTRansition** allows a status to become true on a positive transition of the event.
- **NTRansition** allows a status to become true on a negative transition of the event.
- **MAP** reassigns event reporting at the top level of the status hierarchy.
- **INSTrument.** Both main nodes have this sub node that summarizes the operational and questionable condition of the instrument. Each bit in these two registers represents a slot in the TG700. The summation of each register will feed into bit 13 of its respective parent register.

PRESet. All of the enable registers are set to TRUE so that they return to power-up conditions.

QUEue. QUEue:ENABLE enables certain events or error conditions to be reported. Values that are not explicitly specified are not reported.
STATus:QUEue[:NEXT?] is the same as SYSTem:ERRor?.

Due to the repetitiveness of this subsystem, the details will be covered for the nodes **EVENT**, **CONDition**, **ENABLE**, **PTRansition**, **NTRansition**, and **MAP**. The syntax and examples do not include the full command. Refer to the Command Tree to derive what commands would be appropriate. The following text then describes each major branch within the STATus subsystem.

`[:EVENT] ?`

Performs a destructive reading of the specific event status register. The contents are cleared by reading or by *CLS.

`:CONDition?`

Performs a nondestructive reading of the specified condition register. Contents are cleared as a result of *CLS.

`:ENABle <numeric_value>`

Sets the register that enables the individual bits within the Event Register, which records event transition.

`:ENABle?`

Returns the current Event Register settings.

`:PTRansition <numeric_value>`

Sets the transition register for enabling events to set bits true during a positive transition.

`:PTRansition?`

Returns the transition register for enabling events to set bits true during a positive transition.

`:NTRansition <numeric_value>`

Sets the transition register for enabling events to set bits true during a negative transition.

`:NTRansition?`

Returns the transition register for enabling events to set bits true during a negative transition.

`:STATus:OPERation:MAP <bit>,<event>`

`:STATus:QUESTionable:MAP <bit>,<event>`

Reassigns events to bits in the OPERATION or QUESTionable registers.

SYSTEM Commands

Use these commands to query the system related information and set the front-panel lock function.

Command Tree

```
:SYSTem
  :ERROR
    [:NEXT]?
  :HELP
    :SYNTAX?
  :KLOCK
    :STATE ON|OFF
  :VERSION?
```

Command Description

:SYSTem:ERRor?

Lists the next event in the Error/Event queue. Queue is cleared at power up, upon *CLS, and upon reading the last item.

:SYSTem:HELP:SYNTAX?

Lists correct command syntax.

:SYSTem:KLOCK:STATE ON|OFF

Locks or unlocks the front-panel buttons. You can use 1 or 0 instead of ON or OFF.

:SYSTem:KLOCK:STATE?

Returns the current status of the front-panel buttons.

:SYSTem:VERSION?

Lists the SCPI compliance version. Query only.

Sequence Programming

Sequence programs enable the TG700 to execute routines using SCPI commands. The TG700 accepts sequences written using the Tcl programming language.

Writing a Sequence Program

Sequence programs can be created externally to the TG700 using Tcl programming and loaded via Ethernet interface into the file system of the TG700. Sequences can also be loaded through SCPI commands using the PROGram subsystem commands.

A sequence program can be very simple or it can contain many steps. A running sequence program is interpreted by the Tcl parser and some Tcl formatting information is required. A few points are mentioned here to show why they are used in the sample. Full information on Tcl programming is found in Part 1 of *Tcl and the Tk Toolkit*: Addison-Wesley Publishing Company, 1994.

- Comments in Tcl sequences are preceded by the # symbol as the first nonblank character in the line. The # symbol appearing in the line at other locations is treated as any other character.
- SCPI commands that use double quote marks require an escape backslash (“string\”) in order to pass to SCPI using the Tcl scpi command.
- SCPI commands should all be preceded with the string “scpi”.

Running a Sequence

When you run a sequence, you need to download the corresponding sequence file (.seq) to the SEQUENCE folder (/F0:/SEQUENCE directory) of the TG700 in advance. Stored sequences can be called and started from the SEQUENCE main menu.

Refer to *Using TG7 Comm for File Transfers* on page 3-27 for instructions on how to download a sequence file.

Running a sequence from remote control using SCPI commands requires the following steps:

1. Use the `PROG:SEL:NAME <progrname>` command to select the sequence program to run.

You can also use the `PROG:EXPL:STAT <progrname>,RUN` command at this point to start the sequence named explicitly.

The syntax of the `<progrname>` file can be used without quotes, unless a period is used in the name to separate the base from the extension. If a file extension is used, then quotes are required to convey the name to the TG700.

Examples:

```
prog:expl:stat test1,run  
prog:name "t_0044.tcl"
```

2. Use the `PROG:SEL:STAT RUN` command to start the named sequence. Send `PROG:SEL:STAT STOP` to stop the running sequence if it is not self terminating.

Tcl Programming Changes

The TG700 uses the following extended Tcl commands:

Command: `sleep <seconds> [<tenths> [<hundredths>]]`

Usage: Delay for the specified seconds and optional tenths and hundredths of seconds

Command: `scpi`

Usage: Specifies that the command following is a SCPI command. The Tcl parser passes it immediately to the SCPI command interpreter.



Appendices

Appendix A: Specifications

Tables A-1 through A-3 list the electrical, environmental, and mechanical characteristics of the TG 700 mainframe. For the specifications of a specific generator module or other module, refer to the module User manual. Table A-4 lists the certification and compliances.

The performance requirements listed in the electrical characteristics portion of these specifications apply over an ambient temperature range of 0 °C to +50 °C. The rated accuracies are valid when the instrument is calibrated at an ambient temperature range of +20 °C to +30 °C, after a warm-up time of 20 minutes.

Electrical Characteristics

Table A-1: Electrical characteristics

Characteristic	Performance requirements	Reference information
The number of modules that can be installed	Maximum 4	Only a limited number of some modules can be installed in a TG700 mainframe: AGL7 Maximum 1 AVG7 Maximum 2 AWVG7 Maximum 2 HDVG7 Maximum 2
Clock		
Stability	< 1 ppm/year	
AC power source		
Rating voltage		100 V to 240 VAC
Voltage range		85 V to 250 VAC
Frequency range		48 Hz to 63 Hz
Maximum power		100 W
Maximum current		1.2 A
Heat Dissipation		
Maximum power		100 W maximum. Maximum line current is 1.2 A rms at 50 Hz
Surge current		≤ 40 A peak for equal or less than 5 line cycles, after the instrument has been turned off for at least 30 seconds.
Clearance		
Side		5 cm
Rear		5 cm

Environmental Characteristics

Table A-2: Environmental characteristics

Characteristic	Description
Temperature	
Operating	0 °C to +50 °C
Nonoperating	-20 °C to +60 °C
Relative Humidity	
Operating	20% to 80% (No condensation) Maximum wet-bulb temperature 29.4 °C
Nonoperating	5% to 90% (No condensation) Maximum wet-bulb temperature 40.0 °C
Altitude	
Operating	To 4.5 km (15,000 feet) Maximum operating temperature decreases 1 °C each 300 m above 1.5 km.
Nonoperating	To 15 km (50,000 feet)
Vibration	
Operating	2.65 m/s ² (0.27 G _{rms}), 5 Hz to 500 Hz, 10 min, three axes
Nonoperating	22.3 m/s ² (2.28 G _{rms}), 5 Hz to 500 Hz, 10 min, three axes
Shock	
Nonoperating	294 m/s ² (30 G), half-sine, 11 ms duration

Mechanical Characteristics

Table A-3: Mechanical characteristics

Characteristic	Description
Dimensions	
Height	44 mm
Width	483 mm
Depth	559 mm
Weight ¹	
Net	Approximately 5.5 kg (mainframe only, without rack rail)

¹ Weight of the TG 700 will vary depending on the number and type of generator or other modules installed.

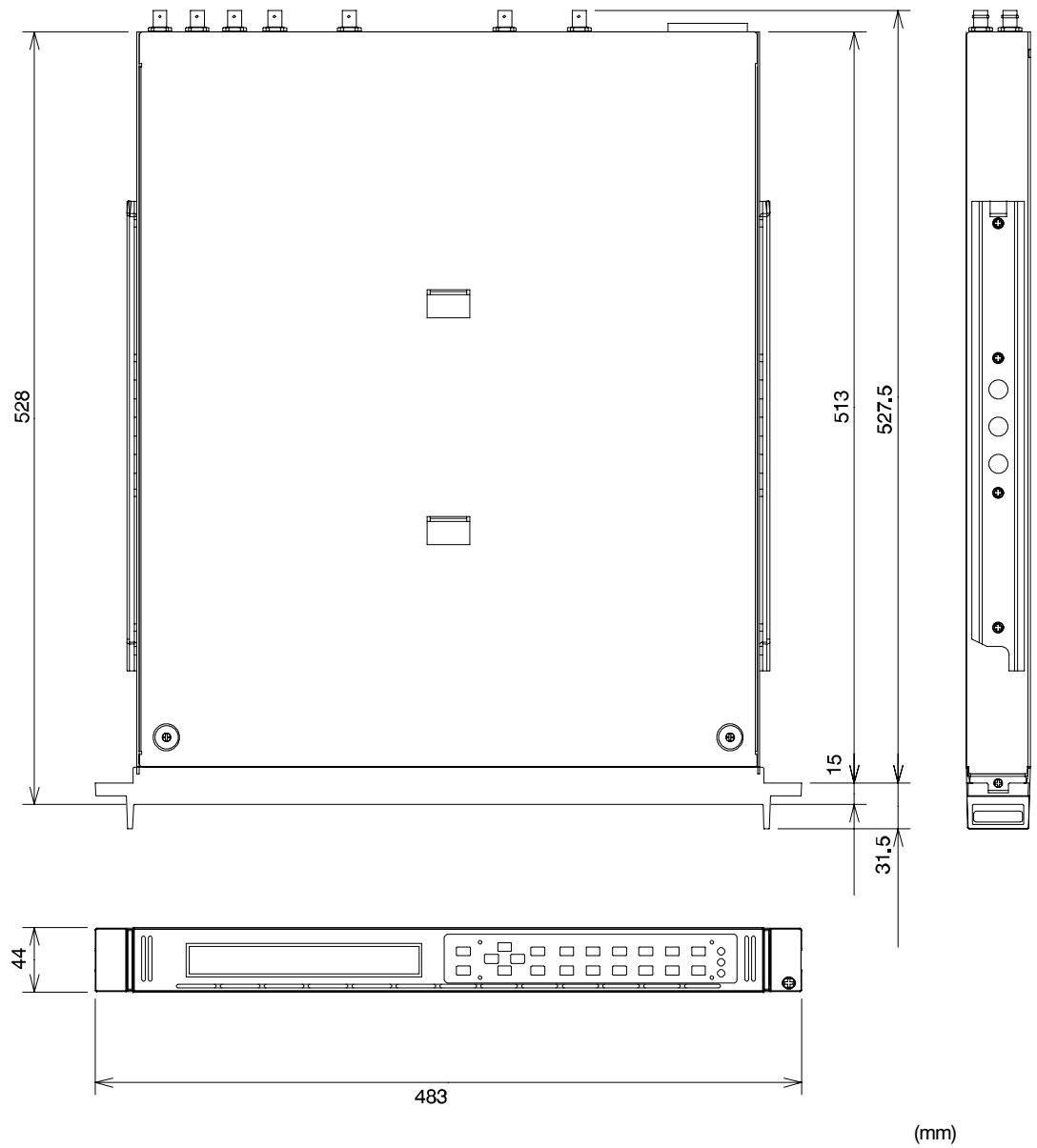

Figure A-1: TG700 dimensions

Certifications and Compliances

Table A-4: Certifications and compliances

Category	Standard or description																										
EC Declaration of Conformity - EMC	<p>Meets the intent of Directive 89/336/EEC for Electromagnetic Compatibility. Compliance was demonstrated to the following specifications as listed in the Official Journal of the European Communities:C</p> <p>EN 55103-1 Emissions:</p> <table> <tr> <td>EN 55022 Class B</td> <td>Radiated and Conducted Emissions</td> </tr> <tr> <td>EN 55103-1 Annex A</td> <td>Magnetic Field Emissions</td> </tr> <tr> <td>EN 55103-1 Annex B</td> <td>Power Line Inrush Current</td> </tr> <tr> <td>EN 61000-3-2</td> <td>AC Power Line Harmonic Current Emissions</td> </tr> <tr> <td>EN 61000-3-3</td> <td>Line Voltage Alteration and Flicker</td> </tr> </table> <p>EN 55103-2 Immunity:</p> <table> <tr> <td>EN 61000-4-2</td> <td>Electrostatic Discharge Immunity</td> </tr> <tr> <td>EN 61000-4-3</td> <td>RF Electromagnetic Field Amplitude Modulated</td> </tr> <tr> <td>EN 61000-4-4</td> <td>Electrical Fast Transient/Burst Immunity</td> </tr> <tr> <td>EN 61000-4-5</td> <td>AC Mains Surge Immunity</td> </tr> <tr> <td>EN 61000-4-6</td> <td>Conducted RF Immunity</td> </tr> <tr> <td>EN 61000-4-8</td> <td>Power Frequency Electromagnetic Field Immunity</td> </tr> <tr> <td>EN 61000-4-11</td> <td>Mains Voltage Dip & Interruption Immunity</td> </tr> <tr> <td>EN 55103-2 Annex A</td> <td>Magnetic Field Immunity</td> </tr> </table> <p>High-quality shielded cables must be used to ensure compliance to the above listed standards.</p>	EN 55022 Class B	Radiated and Conducted Emissions	EN 55103-1 Annex A	Magnetic Field Emissions	EN 55103-1 Annex B	Power Line Inrush Current	EN 61000-3-2	AC Power Line Harmonic Current Emissions	EN 61000-3-3	Line Voltage Alteration and Flicker	EN 61000-4-2	Electrostatic Discharge Immunity	EN 61000-4-3	RF Electromagnetic Field Amplitude Modulated	EN 61000-4-4	Electrical Fast Transient/Burst Immunity	EN 61000-4-5	AC Mains Surge Immunity	EN 61000-4-6	Conducted RF Immunity	EN 61000-4-8	Power Frequency Electromagnetic Field Immunity	EN 61000-4-11	Mains Voltage Dip & Interruption Immunity	EN 55103-2 Annex A	Magnetic Field Immunity
EN 55022 Class B	Radiated and Conducted Emissions																										
EN 55103-1 Annex A	Magnetic Field Emissions																										
EN 55103-1 Annex B	Power Line Inrush Current																										
EN 61000-3-2	AC Power Line Harmonic Current Emissions																										
EN 61000-3-3	Line Voltage Alteration and Flicker																										
EN 61000-4-2	Electrostatic Discharge Immunity																										
EN 61000-4-3	RF Electromagnetic Field Amplitude Modulated																										
EN 61000-4-4	Electrical Fast Transient/Burst Immunity																										
EN 61000-4-5	AC Mains Surge Immunity																										
EN 61000-4-6	Conducted RF Immunity																										
EN 61000-4-8	Power Frequency Electromagnetic Field Immunity																										
EN 61000-4-11	Mains Voltage Dip & Interruption Immunity																										
EN 55103-2 Annex A	Magnetic Field Immunity																										
Australia/New Zealand Declaration of Conformity - EMC	<p>Complies with EMC provision of Radiocommunications Act per the following standard(s):</p> <p>AS/NZS 3548 Industrial, Scientific, and Medical Equipment: 1992</p>																										
Safety	<p>Complies with the following safety standards/regulations:</p> <p>UL 3111-1</p> <p>CSA C22.2 No.1010.1</p> <p>EN 61010-1 with second amendment</p>																										
Installation (Overvoltage) Category	<p>Terminals on this product may have different installation (overvoltage) category designations. The installation categories are:</p> <p>CAT III Distribution-level mains (usually permanently connected). Equipment at this level is typically in a fixed industrial location.</p> <p>CAT II Local-level mains (wall sockets). Equipment at this level includes appliances, portable tools, and similar products. Equipment is usually cord-connected.</p> <p>CAT I Secondary (signal level) or battery operated circuits of electronic equipment.</p>																										

Table A-4: Certifications and compliances (cont.)

Category	Standard or description
Pollution Degree	<p>A measure of the contaminates that could occur in the environment around and within a product. Typically the internal environment inside a product is considered to be the same as the external. Products should be used only in the environment for which they are rated.</p> <p>Pollution Degree 2 Normally only dry, nonconductive pollution occurs. Occasionally a temporary conductivity that is caused by condensation must be expected. This location is a typical office/home environment. Temporary condensation occurs only when the product is out of service.</p>
IEC Characteristics	<p>Equipment type:</p> <p>Test and Measuring Installation Category II (as defined in IEC 61010-1, Annex J) Pollution Degree 2 (as defined IEC 61010-1) Safety Class1 (as defined in IEC 61010-1, Annex H)-grounded product</p>

Appendix B: Module Installation

This section provides instructions for installing and removing modules from the TG700 mainframe. A screwdriver with a #1 Phillips tip is the only tool you need to install or remove a module.



CAUTION. *To prevent damage to the mainframe and module, always remove the power cord before installing or removing a module.*

Preventing Component Damage



CAUTION. *Electrostatic discharge (ESD) can damage components on this module and mainframe. To prevent ESD or other component damage, follow the steps below when installing, removing, or handling modules:*

1. Wear a grounded antistatic wrist strap to discharge the static voltage from your body while installing or removing modules from the TG700 mainframe.
2. Transport and store modules in a static-protected bag or container.
3. Do not slide the module over any surface.
4. Handle modules as little as possible.
5. Do not touch module components or connector pins.
6. Do not use any devices capable of generating or holding a static charge in the work area where you remove, install, or handle modules.
7. Avoid handling modules in areas that have a floor or work-surface covering capable of generating a static charge.
8. Do not remove the module circuit board assembly from the shield. The shield is an important stiffener which prevents damage to surface-mount components.

Installing a Module

To install a module into the mainframe perform the following procedure:

1. Unplug the power cord from the power connector on the rear panel of the mainframe.
2. Select the slot you will use to install the module. Figure B-1 shows a sample configuration with slot numbers.

NOTE. Only one AGL7 module can be installed in the TG700 mainframe, and it must only be installed in slot 1. All other modules may be installed in any slot location.

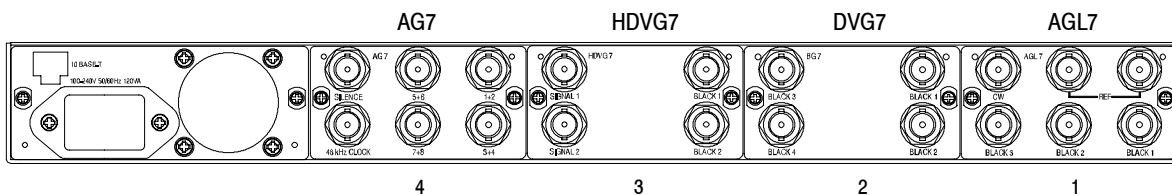

Figure B-1: TG700 slot numbering

NOTE. Any number (up to 4) of the following modules can be installed in the TG700 mainframe:

AG7
ATG7
BG7
DVG7
HDVG7

Only a combined total of two (2) of the following modules can be installed in the TG700 mainframe at the same time:

AVG7
AWVG7
HDVG7

3. Use a screwdriver with a #1 Phillips tip to loosen the two screws on the blank panel attached to the slot you want to use, and then pull it away. See Figure B-2.

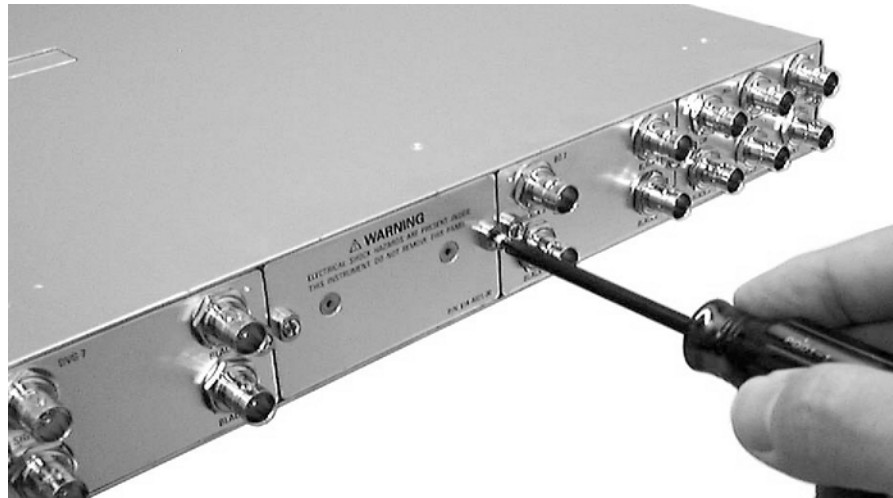

Figure B-2: Removing the blank panel



CAUTION. *Be careful not to damage the parts and cables inside of the module when you insert the module into the mainframe.*

4. Insert the module into the slot, paying attention to the module orientation. See Figure B-3.

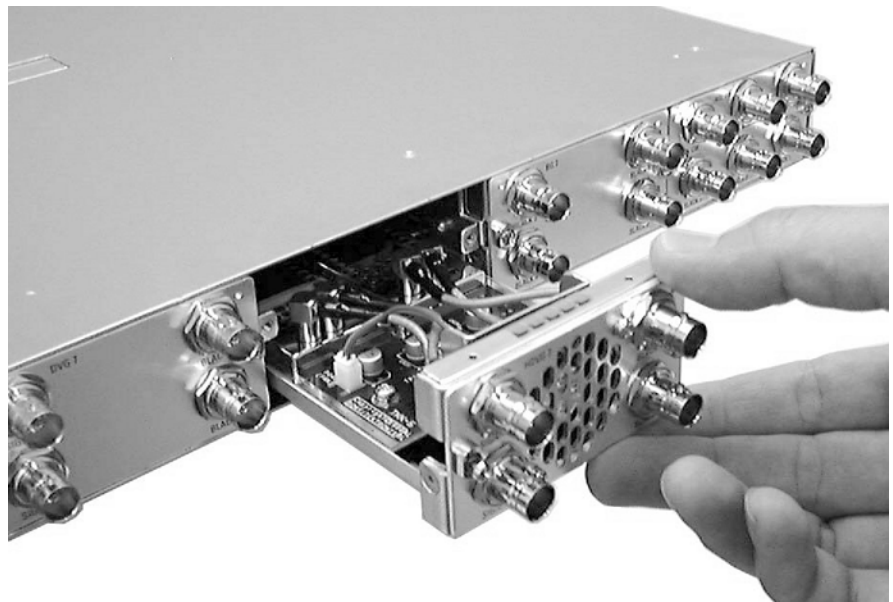

Figure B-3: Installing the module

5. Push the module in until the connector board of the module is firmly engaged with the main board of the mainframe.
6. Tighten the two screws to secure the module to the mainframe. See Figure B-4.

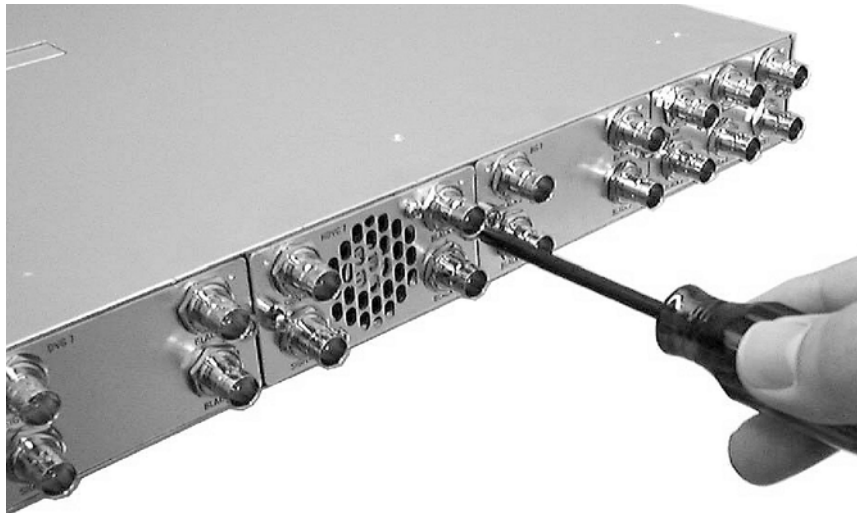

Figure B-4: Securing the module

Removing a module

To remove a module from the mainframe perform the following procedure:



CAUTION. To make module removal easy, attach terminations or BNC cables to the module connectors. The connector may be damaged if too much force is applied to it during module removal.

1. Unplug the power cord from the power connector on the mainframe rear panel.
2. Attach 75 Ω terminations or BNC cables to the BNC connectors on the module to be removed. Module removal becomes easier if the terminations or cables are attached to the connectors at the left and right ends.
3. Use a screwdriver with a #1 Phillips tip to loosen the two screws securing the module to the mainframe.



CAUTION. Be careful not to damage the parts and cables inside of the module when you remove the module from the mainframe.

4. Pull the module slowly toward you while supporting the terminations or BNC cables attached to the connectors. See Figure B-5.

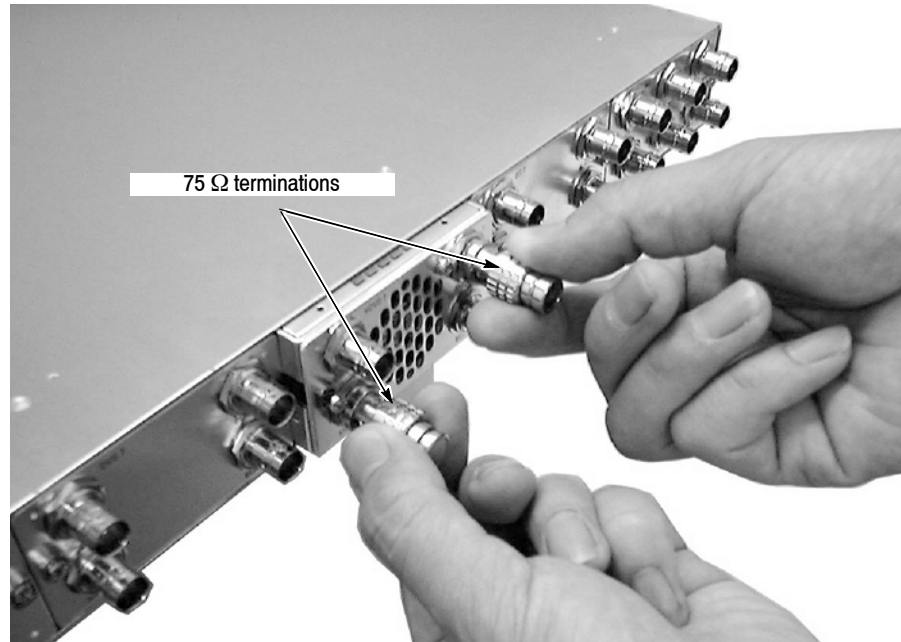

Figure B-5: Removing the module

5. If this empty slot will not be used, you must attach a blank panel to the mainframe to control instrument cooling and EMI emissions.
 - a. Align the blank panel with the open slot of the mainframe.
 - b. Tighten the two screws to secure the blank panel to the mainframe.A blank panel is available as an optional accessory for the TG700 mainframe. Refer to *Accessories* on page 1-2.
6. If you want to install another module into the slot from which the module is removed, perform *Installing a Module* on page B-2.

Appendix C: Network Interface Specifications

The TG700 supports remote control using the Ethernet interface. This section describes the TG700 network interface specifications.

The TCP/IP is used as the network protocol, and the port number is fixed 5000. The commands can be sent from the application program through the socket interface of the TCP/IP. Also, the query can be received through the interface.

Keep the following in mind while controlling the TG700 remotely with the Ethernet interface.

- The Line Feed (LF) code is needed at the end of a message as a terminator.
- The IEEE 488.1 standard (for instance Device Clear, Service Request, etc.) is not supported.
- The Message Exchange Control Protocol in the IEEE 488.2 is not supported. However, the common commands such as *ESE and the event handling features are supported.
- The Indefinite format (the block start at #0) in the <ARBITRARY BLOCK PROGRAM DATA> of the IEEE 488.2 is not supported.

Checking Remote Command Operation

To check remote command operation of the TG700 mainframe perform the following procedure:

1. Connect the TG700 to your PC using an Ethernet cable. Refer to *Connecting to a Network* on page 3-15 for detailed information about how to connect the TG700 to your PC.
2. Click Windows **Start** button and select **Run** from the start menu
3. In the dialog box, type **telnet** and then click **OK**.

The TELNET window appears.

4. Select **Preferences** from the **Terminal** pull-down menu.
5. In the **Preferences** dialog box, check the **Local Echo** check box and then click **OK**.
6. Select **Remote System** from the **Connect** pull-down menu.
7. In the **Connect** dialog box, enter the IP address of the TG700 in the Host Name field and **5000** in the Port field.

8. Click **Connection**.
9. Type ***IDN?** in the command line and press the Enter key.
10. Check that the ID information of the TG700 appears on the PC.

NOTE. *If you use a PC running Windows 2000/XP, connect the TG700 and your PC using the Hyper Terminal application supplied with Windows. Refer to Windows Online Help or other documentation for detailed information about Hyper Terminal.*

Appendix D: Error Messages and Codes

Error codes with a negative value are SCPI standard error codes; errors with a positive value are unique to the TG700.

Command Errors

Command errors are returned when there is a syntax error in the command.

Table D-1: Command errors

Error code	Error message
-100	command error
-101	invalid character
-102	syntax error
-103	invalid separator
-104	data type error
-105	GET not allowed
-108	parameter not allowed
-109	missing parameter
-110	command header error
-111	header separator error
-112	program mnemonic too long
-113	undefined header
-114	header suffix out of range
-120	numeric data error
-121	character
-123	exponent too large
-124	too many digits
-128	numeric data not allowed
-130	suffix error
-131	invalid suffix
-134	suffix too long
-138	suffix not allowed
-140	character data error

Table D-1: Command errors (Cont.)

Error code	Error message
-141	invalid character data
-144	character data too long
-148	character data not allowed
-150	string data error
-151	invalid string data
-158	string data not allowed
-160	block data error
-161	invalid block data
-168	block data not allowed
-170	command expression error
-171	invalid expression
-178	expression data not allowed
-180	macro error
-181	invalid outside macro definition
-183	invalid inside macro definition
-184	macro parameter error

Execution Errors

These error codes are returned when an error is detected while a command is being executed.

Table D-2: Execution errors

Error code	Error message
-200	execution error
-201	invalid while in local
-202	settings lost due to RTL
-210	trigger error
-211	trigger ignored
-212	arm ignored
-213	init ignored
-214	trigger deadlock

Table D-2: Execution errors (Cont.)

Error code	Error message
-215	arm deadlock
-220	parameter error
-221	settings conflict
-222	data out of range
-223	too much data
-224	illegal parameter value
-225	out of memory
-226	lists not same length
-230	data corrupt or stale
-231	data questionable
-240	hardware error
-241	hardware missing
-250	mass storage error
-251	missing mass storage
-252	missing media
-253	corrupt media
-254	media full
-255	directory full
-256	FileName not found
-257	FileName error
-258	media protected
-260	execution expression error
-261	math error in expression
-270	execution macro error
-271	macro syntax error
-272	macro execution error
-273	illegal macro label
-274	execution macro parameter error
-275	macro definition too long
-276	macro recursion error
-277	macro redefinition not allowed
-278	macro header not found
-280	program error

Table D-2: Execution errors (Cont.)

Error code	Error message
-281	cannot create program
-282	illegal program name
-283	illegal variable name
-284	program currently running
-285	program syntax error
-286	program runtime error

Device Specific Errors

These error codes are returned when an internal instrument error is detected. This type of error may indicate a hardware problem.

Table D-3: Device specific errors

Error code	Error message
-300	device specific error
-310	system error
-311	memory error
-312	PUD memory lost
-313	calibration memory lost
-314	save/recall memory lost
-315	configuration memory lost
-330	self test failed
-350	queue overflow

Query Errors

These error codes are returned in response to an unanswered query.

Table D-4: Query errors

Error code	Error message
-400	query error
-410	query interrupted
-420	query unterminated
-430	query deadlocked
-440	query unterminated after indefinite period

Device Errors

These error codes are unique to the TG700 and the installed modules.

Table D-5: Device errors

Error code	Error message
242	module not found
243	module not a generator
249	directory not found
251	standard not compatible with input
252	no signal found on input
253	unable to release clock
254	unable to lock clock
263	signal file not found
264	current signal not saved to file
265	signal file failed to load

Appendix E: Firmware Upgrade

The TG700 firmware needs to be upgraded when a newly released module is installed.

This section describes how to upgrade the firmware.

Equipment Required

The following equipment is required to upgrade the firmware:

- PC with Windows 2000/XP and Ethernet interface installed
- 10 BASE-T Ethernet cable
- TG700 Signal Generator Platform Software Library CD-ROM provided with the new module

Upgrade Procedures

NOTE. *If a downloaded frame picture file is stored in the TG700 mainframe, make sure to move the file from the mainframe to your PC before starting the following procedures. If the mainframe does not have enough memory space, you cannot upgrade the firmware normally.*

Perform the following procedure to upgrade the firmware. It is not necessary to uninstall the earlier version.

1. Connect the 10 BASE-T port on the TG700 rear panel to the Ethernet port on your PC using the Ethernet cable. Refer to *Connecting the TG700 to your PC(s)* on page 3-15 for detailed information about how to connect the TG700 to your PC.
2. Power on the TG700 and your PC.
3. Set the network parameters of the TG700. Refer to *Setting Ethernet Network Parameters* on page 3-16 for detailed information about how to set the parameters.
4. Insert the **TG700 Signal Generator Platform Software Library** CD-ROM provided with the new module into the CD-ROM drive on your PC.

5. Double-click the **D: drive** icon (substitute your CD-ROM drive letter if it is different than D). The PC will display the contents of the TG700 Signal Generator Platform Software Library CD-ROM.
6. Double-click the **UPGRADE** folder. The PC will display the contents of the Upgrade folder.
7. Double-click the **tgUpgrade.exe** icon in the folder. The **TG700 Upgrade** dialog box appears as shown in Figure E-1.

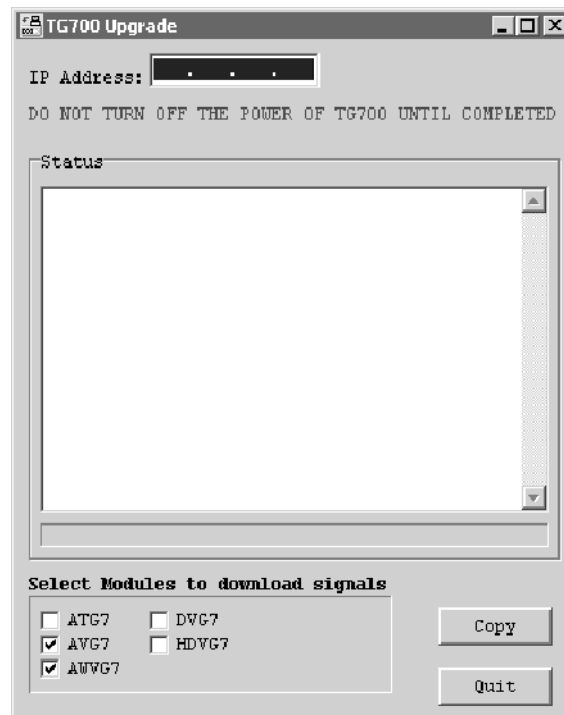

Figure E-1: TG700 Upgrade dialog box

NOTE. In the following cases, an error message appears when you double-click the *tgUpgrade.exe* icon. If this happens, copy the all of the files in the *UPGRADE* folder to the hard disk, and then repeat the operation.

- When you upgrade the TG700 with firmware version 1.3 or earlier and use the ATG7, AVG7, or AWVG7 module in it.
 - When you upgrade the TG700 with firmware version 2.1 or earlier and use the AVG7 or AWVG7 module in it.
-

8. In the dialog box, enter the IP address that you assigned to your TG700.
9. If you want to download the signals for the specified module(s), use the check boxes at the bottom of the dialog box. Normally, you need not select any check boxes. Select the appropriate check box(es) under the following cases:
 - ATG7 check box: when you upgrade the TG700 with firmware version 1.3 or earlier and use the ATG7 module in it.
 - AVG7 check box: when you upgrade the TG700 with firmware version 2.1 or earlier and use the AVG7 module in it.
 - AWVG7 check box: when you upgrade the TG700 with firmware version 2.1 or earlier and use the AWVG7 module in it.
10. Click the **Copy** button. The PC will start transferring the files in the Upgrade folder to the TG700.



CAUTION. Do not power off the TG700 until file transfer is complete. Doing so will prevent the instrument from starting up normally.

11. When the file transfer is complete, the message box shown in Figure E-2 appears.



Figure E-2: Message box appearing after the file transfer is complete

12. Click the **OK** button in the message box.
13. Disconnect the power cable from the power cord connector on the TG700 rear panel, and then connect it again to restart the instrument.
14. If your TG700 includes an HDLG7 module, proceed with the following steps to complete the upgrade:
 - a. Power on the TG700.
 - b. When “Startup TG700” appears on the display, press the **FORMAT** button and leave it pressed until “HDLG7[n]” appears.
 - c. Wait for all modules to boot up.

- d. When “TG700 : PRESET” appears on the display, disconnect the power to the instrument, then connect it again to restart the instrument.

Firmware Version Check

Perform the following procedure to verify that the new firmware version was properly installed:

1. Press the front-panel **MODULE** button to display the TG700 main menu.
2. Use the up (▲) or down (▼) arrow button to select **UTILITY**, and then press the **ENTER** button.
3. Use the up (▲) or down (▼) arrow button to select **VERSION INFO (F/W)**.
4. Use the left (◀) or right (▶) arrow button to select **CPU[0]**.
5. Verify that the new firmware version number is displayed in the menu.

Refer to the *Release Notes* attached to the instrument for information about the new firmware version.

Appendix F: Inspection and Cleaning

Inspect and clean the instrument as often as your operating conditions require. The collection of dirt can cause instrument overheating and operational failure. Dirt acts as an insulating blanket, preventing efficient heat dissipation. Dirt also provides an electrical conduction path that can cause an instrument failure, especially under high-humidity conditions.



CAUTION. Avoid the use of chemical cleaning agents that might damage the plastics used in this instrument. Use only deionized water when cleaning the front-panel controls. Use a 75% ethyl alcohol solution as a cleaner, and rinse with deionized water.

Avoid the use of high-pressure compressed air when cleaning dust from the interior of this instrument. High-pressure air can cause Electro Static Discharge (ESD). Instead, use low-pressure compressed air (about 9 psi).

Exterior Inspection

Using Table F-1 as a guide, inspect the outside of the instrument for damage, wear, and missing parts. You should thoroughly check instruments that appear to have been dropped or otherwise abused to verify correct operation and performance. Immediately repair defects that could cause personal injury or lead to further damage to the instrument.

Table F-1: External inspection check list

Item	Inspect for	Repair action
Cabinet and front panel	Cracks, scratches, deformations, damaged hardware	Replace defective module
Front-panel buttons	Missing or damaged	Repair or replace missing or defective buttons
Connectors	Broken shells, cracked insulation, deformed contacts, and dirt in connectors	Replace defective modules; clear or wash out dirt
Accessories	Missing items or parts of items, bent pins, broken or frayed cables, and damaged connectors	Replace damaged or missing items, frayed cables, and defective modules

Exterior Cleaning

Perform the following steps when you clean the exterior of the instrument:



WARNING. *To avoid injury or death, unplug the power cord from line voltage before cleaning the instrument. Avoid getting moisture inside the instrument during external cleaning. Use only enough liquid to dampen the cleaning cloth.*

1. Remove loose dust on the outside of the instrument with a lint-free cloth.
2. Remove remaining dirt with a lint-free cloth dampened with a general purpose detergent-and-water solution. Do not use abrasive cleaners.
3. Clean the monitor screen with a lint-free cloth dampened with a gentle, general purpose detergent-and-water solution.



Index

Index

Numbers

10 BASE-T port, 2-4

A

Abbreviations, commands, queries, and parameters, 3-82

AC line voltage requirements, 1-6

Accessories

optional, 1-2

standard, 1-2

ALARM menu, 3-24

Arguments

block, 3-86

command, 3-78

example, 3-79

parameters, 3-81

B

Backing up preset files by TG7 Backup, 3-72

Backus-Naur Form, 3-85

BNF (Backus-Naur form), 3-85

Build menu (Frame Picture Generator), 3-44

Build menu (Logo Generator), 3-54

C

Case sensitivity, 3-84

Certifications and compliances, A-4

Characters, Special, 3-87

Cleaning the instrument exterior, F-2

Commands

chaining, 3-83

rules for forming, 3-77

step, 3-78

structure of IEEE 488.2 commands, 3-77, 3-85

syntax, 3-77

Common commands, 3-89

Configuration, hardware installation, 1-4

Constructed Mnemonics, 3-77

Creating a frame picture file, 3-46

Creating a logo file, 3-57

Creating commands, 3-80

Crossover Ethernet cable, 3-15

D

Description, product overview, 1-1

Diagnostic routines, 3-13

DIAGNOSTICS submenu, 3-13

Dialog boxes

Ethernet (TG7 Comm), 3-30

Ethernet (TG7 Setup), 3-62

DISPLAY commands, 3-91

Downloading a file to the TG700 mainframe, 3-36

E

Electrical specifications, A-1

Environmental operating requirements, 1-6

Environmental specifications, A-2

Error codes, D-1

Commands, D-1

Device specific, D-4

Execution, D-2

Hardware, D-4, D-5

Query, D-5

TG700 unique, D-5

Ethernet dialog box (TG7 Comm), 3-30

Ethernet dialog box (TG7 Setup), 3-62

Ethernet parameters, 3-30

Exiting the file copy tools, 3-72

Exiting the Frame Picture Generator application, 3-41

Exiting the Logo Generator application, 3-51

Exiting the TG7 Comm application, 3-31

Exiting the TG7 Setup application, 3-62

Exterior cleaning, F-2

Exterior inspection, F-1

F

Features, 1-1

File copy tools tutorials, 3-72

File menu (Frame Picture Generator), 3-44

File menu (Logo Generator), 3-54

File menu (TG7 Comm), 3-33

File menu (TG7 Setup), 3-64

File transfers, 3-27

Firmware upgrade, E-1

FORMAT button, 2-2

Frame Picture Generator application, 3-39

Frame Picture Generator tutorials, 3-46
FRAME RESET 1, 2-4
FRAME RESET 2, 2-4
FRAME RESET 3, 2-4
Frame reset signals, 2-4
FRAME RESET STATUS submenu, 3-6
Front panel, operation, 2-1
FRONT PANEL ENABLE button, 2-2

G

General Purpose Interface, 3-19
GPI, 3-19
Gray Scale Settings dialog box (Logo Generator), 3-55

H

Hardware installation, 1-4
Help menu (Frame Picture Generator), 3-45
Help menu (Logo Generator), 3-57
Help menu (TG7 Comm), 3-35
Help menu (TG7 Setup), 3-65
Hierarchy Tree, 3-80

I

IEEE 488.2 Common Commands, 3-77, 3-85
IEEE Std 488.2-1987, 3-85
Initial product inspection, 1-4
Inspection and cleaning, F-1
Installation, 1-4-1-7
 hardware, 1-4
installation, rackmount instructions, 1-4
Installing a module, B-2
Installing Frame Picture Generator, 3-39
Installing Logo Generator, 3-49
Installing TG7 Comm, 3-27
Installing TG7 Setup, 3-59
Installing the file copy tools, 3-69
INSTRUMENT commands, 3-92

K

Key features, 1-1

L

LCD display, 2-1
Logo Generator application, 3-49
Logo Generator tutorials, 3-57

M

Mainframe main menu, 3-1
Manual description, xi
Manuals, related, xi
MASS MEMORY commands, 3-93
Mechanical characteristics, Specifications, A-2
Menu control buttons, 2-2
Message Terminators, 3-85
Miscellaneous Settings dialog box (Logo Generator), 3-56
Mnemonics, Constructed, 3-86
MODULE button, 2-2
Module slot, 2-4

N

NETWORK INFORMATION submenu, 3-10
NETWORK SETUP submenu, 3-11, 3-16

O

Operating basics, 2-1
Optional accessories, 1-2
Options
 Option D1 (Calibration Test Data Report), 1-2
 power cords, 1-3

P

Parameter Types Used in Syntax Descriptions, 3-81
PC system requirements for file copy tools, 3-69
PC system requirements for Frame Picture Generator, 3-39
PC system requirements for Logo Generator, 3-49
PC system requirements for TG7 Comm, 3-27
PC system requirements for TG7 Setup, 3-59
Performance requirements, Specifications, A-1
Power connector, 2-3
Preface, xi
PRESET submenu, 3-2
Product Description, 1-1
PROGRAM commands, 3-96
Programming, 3-78
 sequences, 3-103

Q

Queries, 3-80
Quotes, 3-84

R

- Rackmount, installation instructions, 1-4
- Reference indicator, 2-3
- Related Manuals, xi
- Removing a module, B-4
- Restoring preset files by TG7 Restore, 3-74, 3-75
- Rules
 - command forming, 3-77
 - for using SCPI commands, 3-84

S

- SCPI
 - abbreviating, 3-82
 - chaining commands, 3-83
 - commands, 3-80
 - general rules, 3-84
 - parameter types, 3-81
 - programming, 3-78
 - subsystem hierarchy tree, 3-80
- SCPI commands and queries syntax, 3-80–3-84
 - creating commands, 3-80
 - creating queries, 3-80
- SENSE commands, 3-97
- SEQUENCE submenu, 3-4
- Sequences, running, 3-103
- Service, manual, xi
- Setting Ethernet parameters, 3-16
- Setting the GPI, 3-19
- Settings menu (Frame Picture Generator), 3-45
- Settings menu (Logo Generator), 3-54
- SIGNAL ASSIGN submenu, 3-9
- Specifications
 - Electrical, A-1
 - Environmental, A-2
 - Mechanical characteristics, A-2
 - Performance requirements, A-1
- Standard accessories, 1-2
- Starting the file copy tools, 3-72
- Starting the Frame Picture Generator application, 3-41
- Starting the Logo Generator application, 3-51
- Starting the TG7 Comm application, 3-31
- Starting the TG7 Setup application, 3-62
- STATUS commands, 3-98

- Step, 3-78
- Syntax, command, 3-77
- SYSTEM commands, 3-101

T

- Tcl
 - programming, 3-103
 - programming changes, 3-104
- Terminators, message, 3-85
- Test signal buttons, 2-2
- TG7 Backup application, 3-69
- TG7 Comm application, 3-27
- TG7 Comm tutorials, 3-35
- TG7 Duplicator application, 3-69
- TG7 Restore application, 3-69
- TG7 Setup application, 3-59
- TG7 Setup tutorial, 3-66
- Tutorial, TG7 Setup, 3-66
- Tutorials
 - File copy tools, 3-72
 - Frame Picture Generator, 3-46
 - Logo Generator, 3-57
 - TG7 Comm, 3-35

U

- Upgrade procedures, E-1
- Upgrading the firmware, E-1
- Uploading a file to a PC, 3-37, 3-47
- Utility menu (TG7 Comm), 3-35
- UTILITY submenu, 3-7

V

- View menu (TG7 Comm), 3-34
- View menu (TG7 Setup), 3-65

W

- Window menu (Frame Picture Generator), 3-45
- Window menu (TG7 Setup), 3-65

User Manual

Tektronix

AG7
Audio Generator

Copyright © Tektronix. All rights reserved. Licensed software products are owned by Tektronix or its suppliers and are protected by United States copyright laws and international treaty provisions.

Tektronix products are covered by U.S. and foreign patents, issued and pending. Information in this publication supercedes that in all previously published material. Specifications and price change privileges reserved.

TEKTRONIX and TEK are registered trademarks of Tektronix, Inc.

Contacting Tektronix

Tektronix, Inc.
14200 SW Karl Braun Drive
P.O. Box 500
Beaverton, OR 97077
USA

For product information, sales, service, and technical support:

- In North America, call 1-800-833-9200.
- Worldwide, visit www.tektronix.com to find contacts in your area.

Table of Contents

Preface	iii
About This Manual	iii
Related Manuals	iii
Getting Started	
Product Description	1-1
Accessories	1-2
Option	1-2
Installation	1-2
Functional Check	1-2
Operating Basics	
Operating Procedure	2-1
AG7 Module Main Menu	2-2
Rear-Panel Connector	2-5
Factory Default Settings	2-6
Reference	
Syntax	3-1
Programming Model	3-1
SCPI Commands and Queries	3-3
Remote Commands	3-5
OUTPUT Commands	3-5
SENSE Commands	3-7
Appendices	
Appendix A: Specifications	A-1
Electrical Characteristics	A-1
Environmental Characteristics	A-2
Index	

List of Figures

Figure 2-1: AG7 module main menu	2-2
Figure 2-2: CHANNEL submenu	2-3
Figure 2-3: AUDIO TIMING submenu	2-4
Figure 2-4: AG7 module rear-panel connectors	2-5
Figure 2-5: Location of J452 connector pin	2-6
Figure 3-1: Example of SCPI subsystem hierarchy	3-3

List of Tables

Table 1-1: Standard and optional accessories	1-2
Table 2-1: Factory default settings	2-6
Table A-1: AES/EBU serial digital audio outputs	A-1
Table A-2: SILENCE output	A-1
Table A-3: 48 kHz CLOCK output	A-2
Table A-4: Output timing	A-2
Table A-5: Environmental characteristics	A-2

Preface

This manual documents the capabilities, operation, and specifications of the AG7 Audio Generator module.

About This Manual

This manual is composed of the following sections:

- *Getting Started* contains product description and functional check procedure.
- *Operating Basics* explains how to operate the AG7 module using the menus and front-panel buttons.
- *Reference* describes the syntax used in command descriptions and in all programming commands.
- *Appendices* provides the specifications.

Related Manuals

The following documents are also available.

- The *TG700 TV Signal Generator Platform Service Manual* (Tektronix part number 070-A800-XX) describes how to maintain and service the mainframe and generator modules. This manual is an optional accessory.
- The *TG700 TV Signal Generator Platform Module Installation Instructions* (Tektronix part number 070-A824-XX) describes how to install and remove the modules, and how to upgrade the firmware of the mainframe.



Getting Started

Getting Started

This section contains the following information:

- Product description
- Accessories
- Option
- Installation
- Functional check

Product Description

The AG7 Audio Generator module is designed to be installed in the TG700 TV Signal Generator Platform.

The module can output serial digital audio signals that comply with the AES/EBU standard. The module contains the following features:

- 8 channels (4 AES/EBU audio pairs) of serial digital audio outputs with 24 or 20 bits resolution
- Frequencies, amplitudes, and audio clicks are adjustable in every channel
- Silence and 48 kHz clock (word clock) outputs
- Full remote control using Ethernet interface

The module also supports the following audio frequencies:

Silence	500 Hz	2000 Hz	8000 Hz
50 Hz	600 Hz	2400 Hz	9600 Hz
100 Hz	750 Hz	3000 Hz	10000 Hz
150 Hz	800 Hz	3200 Hz	12000 Hz
200 Hz	1000 Hz	4000 Hz	15000 Hz
250 Hz	1200 Hz	4800 Hz	16000 Hz
300 Hz	1500 Hz	5000 Hz	20000 Hz
400 Hz	1600 Hz	6000 Hz	

Accessories

Table 1-1 lists the standard and optional accessories provided with the AG7 Generator module.

Table 1-1: Standard and optional accessories

Accessory	Std.	Opt.	Tektronix part number
TG700 TV Signal Generator Platform Module Installation Instructions	●		070-A824-XX
TG700 Signal Generator Platform Software Library CD-ROM	●		062-A249-XX
TG700 TV Signal Generator Platform Service Manual		●	070-A800-XX

Option

This subsection describes the option available for the AG7 Generator module. The following option is available:

Option D1 (Test data report)

Option D1 (Test Data Report)

A calibration test data report will be provided with the AG7 Generator module when this option is specified.

Installation

Refer to the *TG700 TV Signal Generator Platform Module Installation Instructions* for instructions on how to install the AG7 Generator module.

Functional Check

The following procedure determines whether the module is operating correctly.

Required equipment

The following equipment is required for the functional check:

- Digital audio monitor
- Oscilloscope
- 75 Ω BNC cable
- 75 Ω Termination

Procedure

1. Install the module into the TG700 Platform mainframe using the installation procedures described in the *TG700 TV Signal Generator Platform User Manual*.
2. Power on the TG700 TV Signal Generator Platform by connecting it to the power source. The initialization process for all installed modules is executed.
3. Check that no error messages appear on the LCD display.
4. Warm up the instrument for 20 minutes.
5. Press the front-panel **MODULE** button until the AG7 main menu as shown below appears.



```
AG7 [x] : CHANNEL PARAMETERS
Channel 1
```

6. Connect the **1+2** connector to the digital audio monitor using the 75 Ω BNC cable.
7. Set the digital audio monitor to display the status for the audio data.
8. Check that any CRC error does not appear on the monitor.
9. Change the BNC cable from the **1+2** connector to the **3+4** connector, and check that no CRC errors appear on the monitor.
10. Change the BNC cable from the **3+4** connector to the **5+6** connector, and check that no CRC errors appear on the monitor.
11. Change the BNC cable from the **5+6** connector to the **7+8** connector, and check that no CRC errors appear on the monitor.
12. Change the BNC cable from the **7+8** connector to the **SILENCE** connector, and check that no CRC errors appear on the monitor.
13. Connect the **48 kHz CLOCK** connector to the oscilloscope CH1 input using the 75 Ω BNC cable and 75 Ω termination.
14. Check that the appropriate clock signal is displayed on the screen.



Operating Basics

Operating Basics

This section explains the operation of the AG7 Generator module using the front-panel buttons and menus, followed by a description of the rear-panel connectors

Refer to the *TG700 TV Signal Generator Platform User Manual* for a detailed explanation of the front-panel buttons and LCD display.

Operating Procedure

After the module is installed in the mainframe, and the mainframe is installed in the rack or other location where it will be used, access each function of the module with the following procedure:

1. Connect the power connector on the rear panel and AC electric power source using the power cord.

Electric power is supplied to the mainframe.

2. Wait until the power up initialization process is complete, and check that there are no error messages on the display.
3. Following the initialization process the mainframe main menu appears, as shown below.



TG700: PRESET

4. Press the front-panel **MODULE** button until the AG7 module main menu appears, as shown below.



AG7 [x]: CHANNEL PARAMETERS
Channel 1

5. Use the front-panel arrow buttons to navigate and select items in the main menu and submenus.

The details of the main menu and submenus are explained on the following pages.

AG7 Module Main Menu

You can select the audio channel whose parameters are to be changed, set the audio data resolution, select the frame reset signal to be synchronized, and adjust the timing offset for the audio signal outputs, using the AG7 module main menu.

Use the up (▲) or down (▼) arrow button to scroll through the main menu. Figure 2-1 shows the AG7 module main menu.

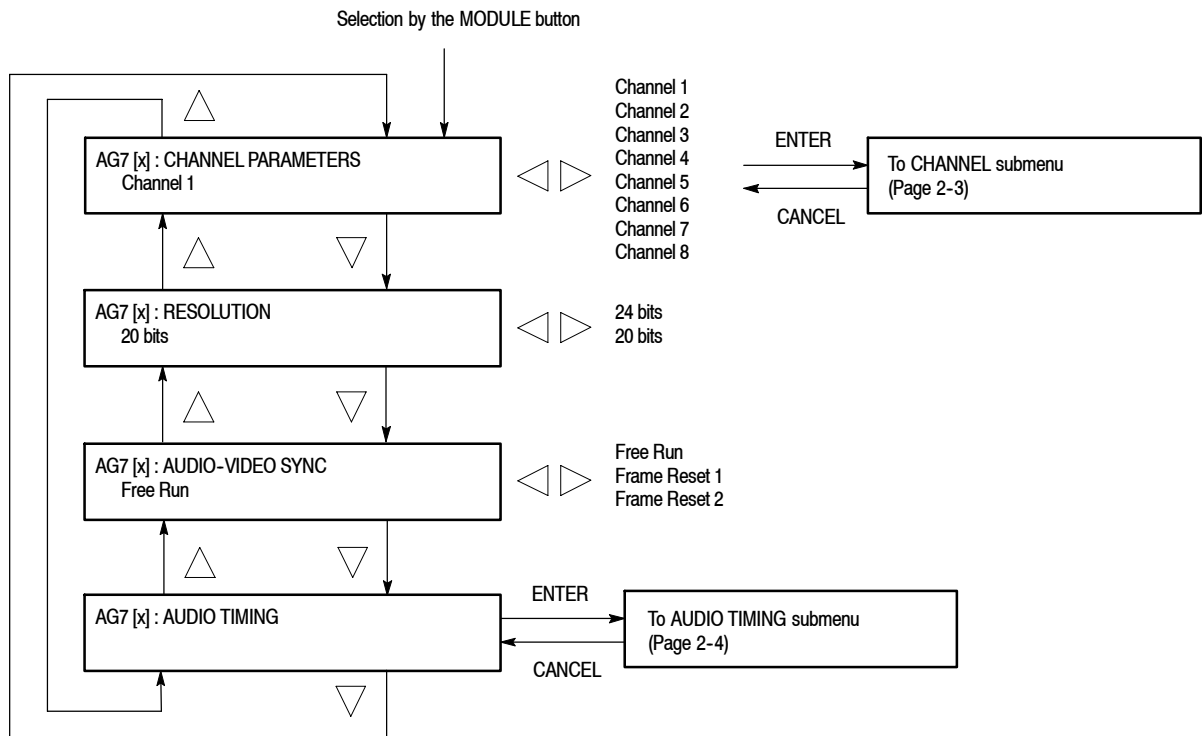

Figure 2- 1: AG7 module main menu

CHANNEL PARAMETERS. Select the channel for which the parameters are to be set, from Channel 1 to Channel 8, by pressing the left (◀) or right (▶) arrow button.

You can access the **CHANNEL** submenu to set frequency, amplitude, and audio click insertion by pressing the front-panel **ENTER** button. Refer to the *CHANNEL Submenu* on page 2-3 for detailed information.

RESOLUTION. Sets the resolution of the serial digital audio signal data. Use the left (◀) or right (▶) arrow button to make the selection. The choices are **24 bits** or **20 bits**. Press the **ENTER** button to enable the selection.

AUDIO-VIDEO SYNC. Selects the frame reset signal synchronized with the digital audio signals. Use the left (◀) or right (▶) arrow button to make the selection. The selection items are **Free Run**, **Frame Reset 1**, and **Frame Reset 2**. For Free Run, the audio signal is not synchronized with any of the frame reset signals. Press the **ENTER** button to enable the selection.

NOTE. *If the frame reset signal used by the audio signals is reset by the change of the video format, the audio signal timing is also reset.*

AUDIO TIMING. Sets the timing offset of the audio signal outputs relative to the genlock signal or the internal reference signal. Select this menu item and press the **ENTER** button to access the **AUDIO TIMING** submenu. Refer to the *AUDIO TIMING Submenu* on page 2-4 for detailed information.

CHANNEL Submenu

This menu allows you to set the frequency, amplitude, and audio click of the selected audio channel. Use the up (▲) or down (▼) arrow button to scroll through the menu items. Figure 2-2 shows the CHANNEL submenu.

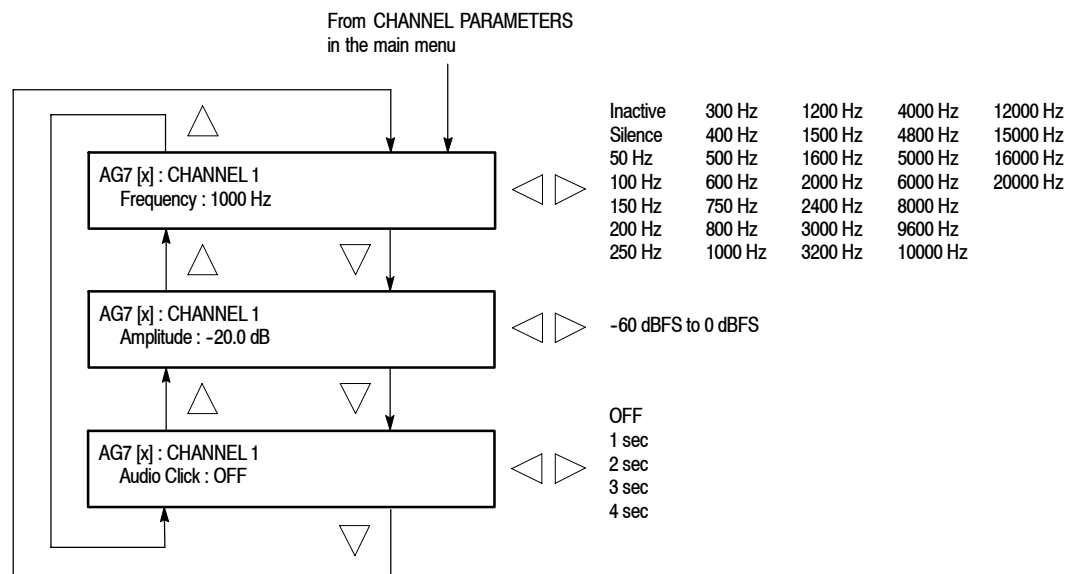

Figure 2-2: CHANNEL submenu

- **Frequency** : Sets the audio signal frequency for the selected audio channel. Use the left (◀) or right (▶) arrow button to make the selection. The choices are:

Inactive	400 Hz	1600 Hz	6000 Hz
Silence	500 Hz	2000 Hz	8000 Hz
50 Hz	600 Hz	2400 Hz	9600 Hz
100 Hz	750 Hz	3000 Hz	10000 Hz
150 Hz	800 Hz	3200 Hz	12000 Hz
200 Hz	1000 Hz	4000 Hz	15000 Hz
250 Hz	1200 Hz	4800 Hz	16000 Hz
300 Hz	1500 Hz	5000 Hz	20000 Hz

When **Inactive** is selected, audio data output is disabled. Press the **ENTER** button to enable the selection.

- **Amplitude** : Sets the audio signal amplitude for the selected audio channel. Use the left (◀) or right (▶) arrow button to set the value. You can set the value from -60 dBFS to 0 dBFS in 1 dBFS steps.
- **Audio Click** : Inserts audio clicks in the selected audio channel. The audio tone, if any, is turned off for an interval around the audio click. Use the left (◀) or right (▶) arrow button to make the selection. The choices are **OFF**, **1 sec**, **2 sec**, **3 sec**, and **4 sec**. Press the **ENTER** button to enable the selection.

Audio Click becomes valid when you select **1 sec** to **4 sec** for the Audio Click rate. When Audio Click is valid, Audio Tone is turned off for 0.25 seconds around the click. For example, if you select **3 sec** for the click rate, the audio tone will be output for 2.75 seconds, and silent for 0.25 seconds; the click occurs during this silence. When Audio Click is **OFF**, the Audio Tone selected in the **FREQUENCY** menu is output continuously. Audio Click makes it easy to identify any channel(s) of the four output channels.

AUDIO TIMING Submenu

This menu allows you to adjust the timing offset of the audio signal outputs relative to the internal reference signal (frame reset signal). Figure 2-3 shows the **AUDIO TIMING** submenu.

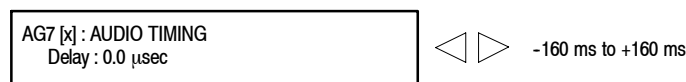

Figure 2-3: AUDIO TIMING submenu

Use the left (◀) or right (▶) arrow button to change the value. You can set the value from -160 ms to +160 ms in 1 μs steps. A minus timing value is set as **Delay** and plus is set as **Advance**.

NOTE. You can reset the timing offset to zero by pressing the left (◀) and right (▶) arrow buttons simultaneously.

Rear-Panel Connectors

The AG7 Generator module is equipped with four AES/EBU serial digital audio pair outputs (1+2, 3+4, 5+6, and 7+8), SILENCE output, and 48 kHz CLOCK output connectors. Figure 2-4 shows the AG7 Generator module rear-panel connectors.

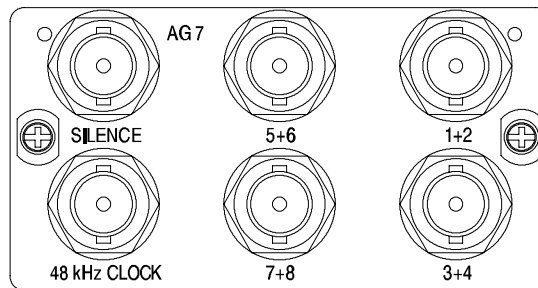

Figure 2-4: AG7 module rear-panel connectors

- **1+2** : AES/EBU serial digital audio output for channels 1 and 2
- **3+4** : AES/EBU serial digital audio output for channels 3 and 4
- **5+6** : AES/EBU serial digital audio output for channels 5 and 6
- **7+8** : AES/EBU serial digital audio output for channels 7 and 8
- **SILENCE** : Silence signal (DAR signal) output
- **48 kHz CLOCK** : 48 kHz clock signal output

Setting the Clock Output Level

The output level of the 48 kHz clock signal can be set to either a CMOS compatible level or 1 V. This feature is available through jumper **J452** on the circuit board. Figure 2-5 shows the location of **J452**.

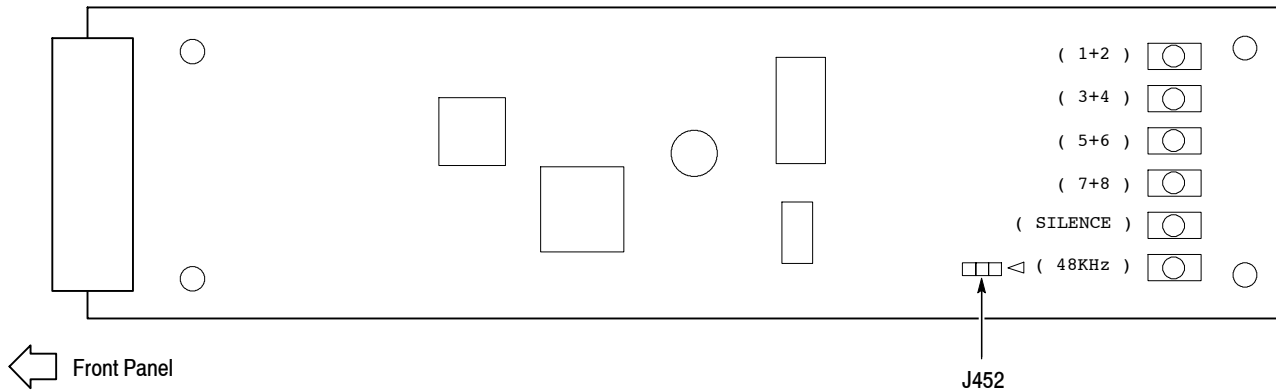

Figure 2-5: Location of J452 connector pin

When you place the jumper on pins 3-4 of J452, the clock signal output level is CMOS compatible. The jumper is placed in this position when the module is shipped.

When you move the jumper to pins 1-2 of J452, the clock signal output level is set to 1V.

Factory Default Settings

Table 2-1 shows the factory default settings for the AG7 Generator module. These settings are recalled when you select **Factory Default** from the **PRESET : RECALL** menu item in the mainframe main menu.

Table 2-1: Factory default settings

Menu item name	Settings
CHANNEL 1 to CHANNEL 8	
Frequency	1000 Hz
Amplitude	-20.0 dBFS
Audio Click	OFF
RESOLUTION	20 bits
AUDIO-VIDEO SYNC	Free Run
AUDIO TIMING	
Delay or Advance	0.0 μ sec



Reference

Syntax

This section contains information on the Standard Commands for Programmable Instruments (SCPI) and the programming structure you can use to program your AG7 Generator module.

Programming Model

Specific conditions must exist before programming commands will affect the test signal generated by a module.

Selecting the Module

Select the module by using the :INSTRument:SElect command before executing any commands. Many of the commands used by the AG7 module are shared by several modules and will be accepted without a reported error.

Command Arguments

Many commands will accept either string or numeric arguments. For example: a boolean argument can either be "1" or "ON".

Signal parameter commands that have a :STEP node can accept either a numeric value or a string argument that refers to the :STEP increment.

Signal parameter commands with a :STEP node will accept the following strings in addition to a numeric value:

UP. Use this argument to increase the parameter value one increment as defined by the :STEP value.

DOWN. Use this argument to decrease the parameter value one increment as defined by the :STEP value.

MINimum. Use this argument to set the parameter value to the minimum acceptable value.

MAXimum. Use this argument to set the parameter value to the maximum acceptable value.

DEFault. Use this argument to set the parameter value to the default value.

Query Arguments

If you send a query with no argument, the response is the current value. You can also use **MINimum**, **MAXimum**, and **DEFault** as arguments for queries whose command form can use these arguments (refer to the command syntax for the specific command). Instead of returning the current value, queries using these arguments return the following information:

MINimum. Returns the minimum acceptable value.

MAXimum. Returns the maximum acceptable value.

DEFault. Returns the default value.

Argument Example

The following example demonstrates the effect of each of the arguments when used with a step value.

1. `:INSTRument:SElect "HDVG7:#"` selects the digital video generator module located in the slot number indicated by the “#” symbol.
2. `:OUTPut:CIRClE:STATe ON` displays a circle on the video display.

NOTE. `:OUTPut:CIRClE:DIAMeter` uses an argument that is the percent of picture height.

3. `:OUTPut:CIRClE:DIAMeter DEFaul t` sets the circle diameter to 90 percent of the screen height.
4. `:OUTPut:CIRClE:DIAMeter:STEP 10` sets the step increment to 10 percent.
5. `:OUTPut:CIRClE:DIAMeter DOWN` changes the circle diameter to 80 percent of the screen height.
6. `:OUTPut:CIRClE:DIAMeter 50` changes the circle diameter to 50 percent of the screen height.
7. `:OUTPut:CIRClE:DIAMeter MAXimum` changes the circle diameter to 100 percent of the screen height.
8. `:OUTPut:CIRClE:DIAMeter MINimum` changes the circle diameter to 0 percent of the screen height.
9. `:OUTPut:CIRClE:DIAMeter UP` changes the circle diameter to 10 percent of the screen height.
10. `:OUTPut:CIRClE:DIAMeter? MAXimum` queries the maximum circle diameter (not the current diameter). The query returns the value of 100 percent, which is the maximum circle diameter allowable.

SCPI Commands and Queries

SCPI is a standard created by a consortium that provides guidelines for remote programming of instruments. These guidelines provide a consistent programming environment for instrument control and data transfer. This environment uses defined programming messages, instrument responses, and data format across all SCPI instruments, regardless of manufacturer. The AG7 Generator module uses a command language based on the SCPI standard.

The SCPI language is based on a hierarchical or tree structure (see Figure 3-1) that represents a subsystem. The top level of the tree is the root node; it is followed by one or more lower-level nodes.

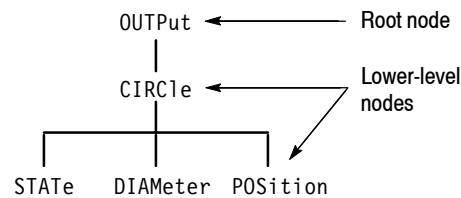

Figure 3-1: Example of SCPI subsystem hierarchy

You can create commands and queries from these subsystem hierarchy trees. Commands specify actions for the instrument to perform. Queries return measurement data and information about parameter settings.

For more information on SCPI commands and programming structure, refer to the *TG700 Signal Generator Platform User Manual*.

Remote Commands

This section describes the command sets used for the AG7 Generator module remote operation. The commands for the module are divided into the following groups:

- OUTPUT commands
- SENSE commands

OUTPUT Commands

Use these commands to set the parameters for each audio channel, the audio data resolution, and the synchronization state relative to the frame reset signals.

Command Tree

```
:OUTPut
  :AUDio
    :CHANnel<n>
      :AMPLitude      <numeric_value>
      :FREQuency      <numeric_value>
      :CLICK           0|1|2|3|4
    :NBITS
    :SYNChronized     FREErUN|FRAME_ONE|FRAME_TWO
```

Command Description

`:OUTPut:AUDio:CHANnel<n>:AMPLitude <numeric_value>`

Sets the amplitude of a specific audio channel. The numeric value can range from -60 dBFS to 0 dBFS in 1 dBFS steps. The <n> in the command represents the channel number. You can use any channel number from 1 through 8.

`:OUTPut:AUDio:CHANnel<n>:AMPLitude?`

Returns the amplitude of a specific audio channel. The <n> in the command represents the channel number. You can use any channel number from 1 through 8.

`:OUTPut:AUDio:CHANnel<n>:FREQuency <numeric_value>`

Sets the frequency of a specific audio channel. The unit is Hertz. The choices are 0, 50, 100, 150, 200, 250, 300, 400, 500, 600, 750, 800, 1000, 1200, 1500, 1600, 2000, 2400, 3000, 3200, 4000, 4800, 5000, 6000, 8000, 9600, 10000, 12000, 15000, 16000, and 20000. The <n> in the command represents the channel number. You can use any channel number from 1 through 8.

`:OUTPut:AUDio:CHANnel<n>:FREQuency?`

Returns the frequency of a specific audio channel. The <n> in the command represents the channel number. You can use any channel number from 1 through 8.

`:OUTPut:AUDio:CHANnel<n>:CLICk 0|1|2|3|4`

Sets the audio click of a specific audio channel. The choices are 1 sec to 4 sec, or 0. When 1 to 4 is selected, the audio click becomes valid. When audio click is valid, audio tone is turned off for 0.25 seconds around the time of the click. The <n> in the command represents the channel number. You can use any channel number from 1 through 8.

`:OUTPut:AUDio:CHANnel<n>:CLICk?`

Returns the audio click setting for the specified audio channel. The <n> in the command represents the channel number. You can use any channel number from 1 through 8.

`:OUTPut:AUDio:NBITs 20|24`

Sets the sample bits of the audio signal. The choices are 20 bits or 24 bits.

`:OUTPut:AUDio:NBITs?`

Returns the sample bits of the audio signal.

`:OUTPut:AUDio:SYNChronized FREErun|FRAME_ONE|FRAME_TWO`

Selects the frame reset signal to synchronize with the audio signal. The choices are FREErun (free run), FRAME_ONE (frame reset signal 1), and FRAME_TWO (frame reset signal 2). For FREErun, the audio signal is not synchronized with any of the frame reset signals.

`:OUTPut:AUDio:SYNChronized?`

Returns the frame reset signal synchronized with the audio signal.

SENSE Commands

Use these commands to adjust the timing offset of the audio outputs relative to the internal reference signal (frame reset signal).

Command Tree

```
:SENSe
  :CORRection
    :MDElay          <numeric_value>
    :STEP            <numeric_value>
```

Command Description

`:SENSe:CORRection:MDElay <numeric_value>`

Sets the timing offset of the audio outputs. The numeric values range from -160 ms to 160 ms in 1 μ s steps. You can use UP, DOWN, or DEF instead of the numeric values.

`:SENSe:CORRection:MDElay?`

Returns the timing offset of the audio outputs.

`:SENSe:CORRection:MDElay:STEP <numeric_value>`

Sets the step increment used by the UP or DOWN commands. The unit is microseconds.

`:SENSe:CORRection:MDElay:STEP?`

Returns the step increment used by the UP or DOWN commands.



Appendices

Appendix A: Specifications

Tables A-1 through A-5 list the electrical characteristics and the environmental characteristics of the AG7 Audio Generator module.

Electrical Characteristics

Table A- 1: AES/EBU serial digital audio outputs

Characteristic	Performance requirements	Reference information
Connector	4	BNC
Number of channels	8	1+2, 3+4, 5+6, and 7+8
Quantized resolution	20 or 24 bits	User selectable
Audio tone		
Frequency	Silence to 20 kHz	31 discrete settings
Level	0 to -60 dBFS in 1 dB steps	
Pre-emphasis		None
Output level	1 ± 0.1 V	Measured across 75 Ω .
Required receiver termination	$75 \Omega \pm 10\%$	
Jitter	Within $\pm 20\%$	
Rise and fall times	Between 30 ns and 44 ns	Measured from the 10 % to 90% points.

Table A- 2: SILENCE output

Characteristic	Performance requirements	Reference information
SILENCE		Same signal as AES/EBU Serial Digital Audio "Silence".
Connector		BNC
Output level	1 ± 0.1 V	Measured across 75 Ω .
Required receiver termination	$75 \Omega \pm 10\%$	
Jitter	Within $\pm 20\%$	
Rise and fall times	Between 30 ns and 44 ns	Measured from the 10% to 90% points.

Table A-3: 48 kHz CLOCK output

Characteristic	Performance requirements	Reference information
48 kHz CLOCK		Reference Clock for AES/EBU Serial Digital Audio.
Connector		BNC
Output level		User selectable by the internal jumper. Level 1 is selected at the factory.
Level 1	CMOS compatible	High > 2.1 V, Low < 0.8 V
Level 2	1 ± 0.1 V	Measured across 75 Ω .

Table A-4: Output timing

Characteristic	Performance requirements	Reference information
Range	± 160 ms	Relative to the frame reset signal.
Resolution	1 μ s	

Environmental Characteristics

Table A-5: Environmental characteristics

Characteristic	Description
Temperature	
Operating	0 °C to +50 °C
Nonoperating	-20 °C to +60 °C
Relative Humidity	
Operating	20% to 80% (No condensation); Maximum wet-bulb temperature 29.4 °C
Nonoperating	5% to 90% (No condensation); Maximum wet-bulb temperature 40.0 °C
Altitude	
Operating	To 4.5 km (15,000 feet) Maximum operating temperature decreases 1 °C each 300 m above 1.5 km.
Nonoperating	To 15 km (50,000 feet)
Vibration	
Operating	3.04 m/s ² (0.31 G _{rms}), 5 Hz to 500 Hz, 10 min, three axes
Nonoperating	23.3 m/s ² (2.38 G _{rms}), 5 Hz to 500 Hz, 10 min, three axes
Shock	
Nonoperating	294 m/s ² (30 G), half-sine, 11 ms duration



Index

Index

Numbers

1+2 connector, 2-5
3+4 connector, 2-5
48 kHz CLOCK connector, 2-5
5+6 connector, 2-5
7+8 connector, 2-5

A

Accessories
 optional, 1-2
 standard, 1-2
AG7 features, 1-1
AG7 module main menu, 2-2
 AUDIO TIMING, 2-3
 AUDIO-VIDEO SYNC, 2-3
 CHANNEL PARAMETERS, 2-2
 RESOLUTION, 2-2
Audio click, 2-4
Audio timing, 2-4
AUDIO TIMING submenu, 2-4

C

CHANNEL submenu, 2-3
Commands
 Rules for forming, 3-1
 Syntax, 3-1

E

Electrical specifications, A-1
Environmental specifications, A-2

F

Factory default settings, 2-6
Functional check, 1-2
Functional command groups, 3-5

H

Hierarchy (SCPI), 3-3

I

Installation, 1-2

M

Manuals, Related, iii

O

Operating procedure, 2-1
Option, 1-2
Optional accessories, 1-2
OUTPUT commands, 3-5

P

Product description, 1-1

R

Rear-panel connectors, 2-5
Related Manuals, iii
Rules, Command forming, 3-1

S

SCPI, Subsystem hierarchy tree, 3-3
SCPI commands and queries syntax, 3-3-3-4
SENSE commands, 3-7
SILENCE connector, 2-5
Specifications
 Electrical, A-1
 Environmental, A-2
Standard accessories, 1-2
Syntax, Command, 3-1

User Manual



AGL7 Analog Genlock Module

Copyright © Tektronix. All rights reserved. Licensed software products are owned by Tektronix or its suppliers and are protected by United States copyright laws and international treaty provisions.

Tektronix products are covered by U.S. and foreign patents, issued and pending. Information in this publication supercedes that in all previously published material. Specifications and price change privileges reserved.

TEKTRONIX and TEK are registered trademarks of Tektronix, Inc.

Contacting Tektronix

Tektronix, Inc.
14200 SW Karl Braun Drive
P.O. Box 500
Beaverton, OR 97077
USA

For product information, sales, service, and technical support:

- In North America, call 1-800-833-9200.
- Worldwide, visit www.tektronix.com to find contacts in your area.

Table of Contents

Preface	iii
About This Manual	iii
Related Manuals	iii
Getting Started	
Product Description	1-1
Accessories	1-2
Option	1-2
Installation	1-2
Functional Check	1-2
Operating Basics	
Operating Procedure	2-1
AGL7 Module Main Menu	2-2
Rear-Panel Connectors	2-10
Factory Default Settings	2-12
Reference	
Syntax	3-1
Programming Model	3-1
SCPI Commands and Queries	3-3
Remote Commands	3-5
INPUT Commands	3-5
SOURCE Commands	3-7
OUTPUT Commands	3-8
SENSE Commands	3-10
Appendices	
Appendix A: Specifications	A-1
Electrical Characteristics	A-1
Environmental Characteristics	A-3
Index	

List of Figures

Figure 2-1: AGL7 module main menu	2-2
Figure 2-2: GENLOCK submenu	2-3
Figure 2-3: OUTPUT submenu	2-5
Figure 2-4: SIGNAL submenu	2-7
Figure 2-5: TIMING submenu	2-8
Figure 2-6: AGL7 module rear-panel connectors	2-10
Figure 2-7: Location of the J040 and J960 connectors	2-11
Figure 3-1: Example of SCPI subsystem hierarchy	3-3

List of Tables

Table 1-1: Standard and optional accessories	1-2
Table 2-1: Timing adjustment ranges for input signals	2-9
Table 2-2: Timing adjustment ranges for output signals	2-9
Table 2-3: Factory default settings	2-12
Table A-1: Genlock function	A-1
Table A-2: Black burst signal and HDTV trilevel sync signal outputs	A-2
Table A-3: Word clock signal output*	A-2
Table A-4: Environmental characteristics	A-3

Preface

This manual documents the capabilities, operation, and specifications of the AGL7 Analog Genlock module.

About This Manual

This manual is composed of the following sections:

- *Getting Started* contains product description and functional check procedure.
- *Operating Basics* explains how to operate the AGL7 module using the menus and front-panel buttons.
- *Reference* provides the syntax used in command descriptions and describes all programming commands.
- *Appendices* provides the specifications.

Related Manuals

The following documents are also available.

- The *TG700 TV Signal Generator Platform Service Manual* (Tektronix part number 070-A800-XX) describes how to maintain and service the mainframe and generator modules. This manual is an optional accessory.
- The *TG700 TV Signal Generator Platform Module Installation Instructions* (Tektronix part number 070-A824-XX) describes how to install and remove the modules, and how to upgrade the firmware of the mainframe.



Getting Started

Getting Started

This section contains the following information:

- Product description
- Accessories
- Option
- installation
- Functional check

Product Description

The AGL7 Analog Genlock module is designed to be installed in the TG700 TV Signal Generation Platform.

The module provides genlock function for the mainframe and installed modules. It is equipped with two reference inputs, the loophrough inputs and the terminated CW input. The AGL7 module can genlock the following signals:

- NTSC black burst signal: burst lock or sync lock
- PAL black burst signal: burst lock and sync lock
- HDTV trilevel sync signal
- CW: 1, 3.58 (NTSC sub-carrier), 4.43 (PAL sub-carrier), 5, and 10 MHz

In addition, there are three signal output connectors provided on the rear panel which can output black burst signals and HDTV trilevel sync signals.

Accessories

Table 2-1 lists the standard and optional accessories provided with the AGL7 Genlock module.

Table 1-1: Standard and optional accessories

Accessory	Std.	Opt.	Tektronix part number
TG700 TV Signal Generator Platform Module Installation Instructions	•		070-A824-XX
TG700 Signal Generator Platform Software Library CD-ROM	•		062-A249-XX
TG700 TV Signal Generator Platform Service Manual		•	070-A800-XX

Option

This subsection describes the option available for the AGL7 Genlock module. The following option is available:

Option D1 (Test data report)

Option D1 (Test Data Report)

A calibration test data report will be provided with the AGL7 Genlock module when this option is specified.

Installation

Refer to the *TG700 TV Signal Generator Platform Module Installation Instructions* for instructions on how to install the AGL7 Genlock module.

Functional Check

The following procedure determines whether the module is operating correctly.

Required equipment

The following equipment is required for the functional check:

- TV signal generator
- NTSC/PAL waveform monitor
- HDTV waveform monitor
- 75 Ω BNC cable
- 75 Ω termination

Procedure

1. Install the module into the TG700 Platform mainframe using the installation procedures described in the *TG700 TV Signal Generator Platform User Manual*.
2. Power on the TG700 TV Signal Generator Platform by connecting it to the power source. The initialization process for all installed modules is executed.
3. Check that no error messages appear on the LCD display.
4. Warm up the instrument for 20 minutes.

Genlock Function.

5. Press the front-panel **MODULE** button until the AGL7 main menu shown below appears.

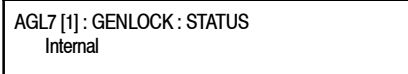

AGL7 [1]: GENLOCK: STATUS
Internal

6. Press the up (▲) or down (▼) arrow button to select **GENLOCK** from the main menu and then press the **ENTER** button.
7. Press the left (◀) or right (▶) arrow button to select **Internal** and then press the **ENTER** button.
8. Check that **INT.REF** indicator at the right side of the front panel lights. This shows that the instrument is using the internal reference signal.
9. Connect one of the TV signal generators output connectors to the AGL7 **REF** connector, using the 75 Ω BNC cable. Terminate the other side of the **REF** connector with the 75 Ω termination.
10. Press the left (◀) or right (▶) arrow button to select the menu item corresponding to the input signal and then press the **ENTER** button.
11. Check that **EXT.REF** indicator at the right side of the front panel lights. This shows that the instrument is locked to the input signal.
12. Disconnect the BNC cable from the REF connector.
13. Check that **EXT.REF** indicator at the right side of the front panel blinks. This shows that the appropriate external reference signal is not being input to the REF connector.

Black Signal Outputs.

14. Press the front-panel **CANCEL** button.
15. Press the up (▲) or down (▼) arrow button to select **SELECT OUTPUT** from the main menu.
16. Press the left (◀) or right (▶) arrow button to select **BLACK 1**, then press the **ENTER** button. The **SELECT FORMAT** submenu shown below appears.

AGL7 [1] : BLACK 1 : SELECT FORMAT
NTSC

17. Press the left (◀) or right (▶) arrow button to select **NTSC** or **PAL** for your waveform monitor and then press the **ENTER** button. This appears the **SIGNAL** submenu shown below.

AGL7 [1] : BLACK 1 : NTSC
Black Burst

18. Press the left (◀) or right (▶) arrow button to select **Black Burst**, then press the **ENTER** button.
19. Connect the **BLACK 1** connector to the NTSC/PAL waveform monitor using the 75 Ω BNC cable.
20. Set the waveform monitor to view the black burst signal.
21. Check that the appropriate black burst signal is displayed.
22. Press the **CANCEL** button twice to display the **SELECT OUTPUT** menu.
23. Press the left (◀) or right (▶) arrow button to select **BLACK 2**, then press the **ENTER** button.
24. Repeat Steps 17 and 18.
25. Connect the **BLACK 2** connector to the NTSC/PAL waveform monitor using the 75 Ω BNC cable.
26. Set the waveform monitor to view the black burst signal.
27. Check that the appropriate black burst signal is displayed.
28. Press the **CANCEL** button twice to display the **SELECT OUTPUT** menu.

29. Press the left (◀) or right (▶) arrow button to select **BLACK 3** and then press the **ENTER** button. This appears the SELECT FORMAT submenu.
30. Press the left (◀) or right (▶) arrow button to select **1080 60i** and then press the **ENTER** button.
31. Connect the **BLACK 3** connector to the HDTV waveform monitor using the 75 Ω BNC cable.
32. Check that the appropriate HDTV trilevel sync signal is displayed.



Operating Basics

Operating Basics

This section explains the operation of the AGL7 Genlock module using the front-panel buttons and menus, followed by a description of the rear-panel connectors

Refer to the *TG700 TV Signal Generator Platform User Manual* for a detailed explanation of the front-panel buttons and LCD display.

Operating Procedure

After the module is installed in the mainframe, and the mainframe is installed in the rack or other location where it will be used, access each function of the module with the following procedure:

1. Connect the power connector on the rear panel and AC electric power source using the power cord.

Electric power is supplied to the mainframe.

2. Wait until the power up initialization process is complete, and check that there are no error messages on the display.
3. Following the initialization process the mainframe main menu appears, as shown below.



TG700: PRESET

4. Press the front-panel **MODULE** button until the AGL7 module main menu appears, as shown below.



AGL7 [1]: GENLOCK: STATUS
Internal

5. Use the front-panel arrow buttons to navigate and select items in the main menu and submenus.

The details of the main menu and submenus are explained on the following pages.

AGL7 Module Main Menu

You can select the genlock source and the output whose parameters are to be changed using the AGL7 module main menu.

Use the up (▲) or down (▼) arrow button to scroll through the main menu. Figure 2-1 shows the AGL7 module main menu.

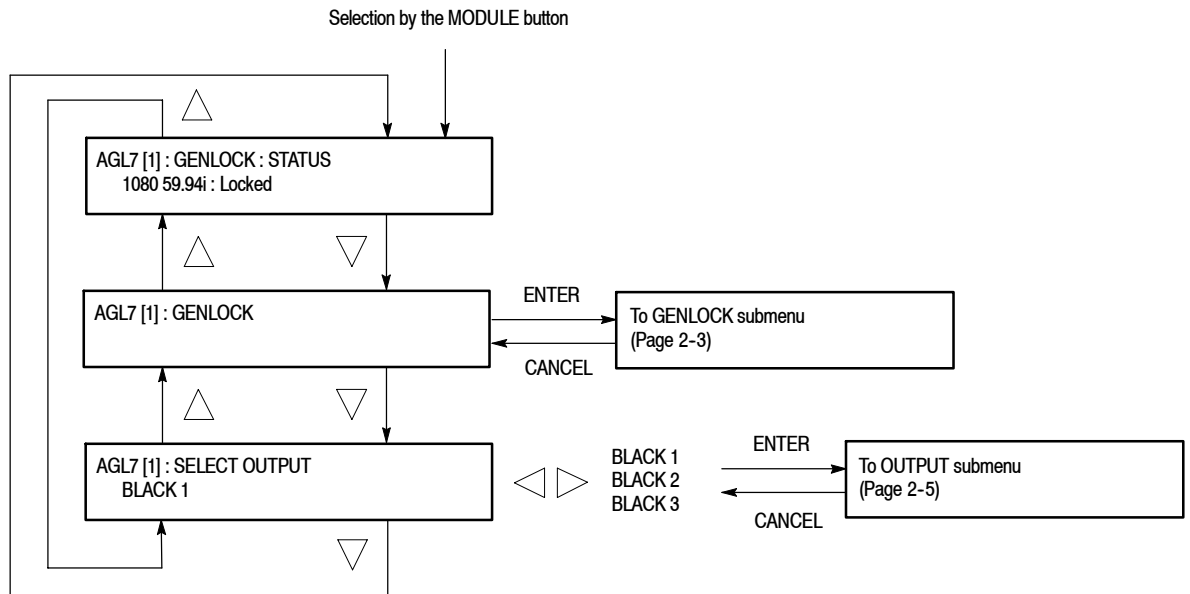

Figure 2- 1: AGL7 module main menu

STATUS. Displays the genlock source and status. The possible messages for the status are as follows: **Locked**, **Loss of Lock**, and **No signal**.

GENLOCK. Selects the genlock source and sets the timing offset of the genlock signal relative to the internal reference signal. When you select this menu item and press the ENTER button, you will access the GENLOCK submenu. Refer to *GENLOCK Submenu* on page 2-3 for detailed information.

SELECT OUTPUT. Selects the output FOR you to change the signal format, output signal, and timing offset relative to the internal reference signal (frame reset signal). Use the left (◀) or right (▶) arrow button to select **BLACK 1**, **BLACK 2**, or **BLACK 3**. When you select any of these and press the ENTER button, you will access the OUTPUT submenu to set the parameters of the selected output. Refer to *OUTPUT Submenu* on page 2-5 for detailed information.

GENLOCK Submenu

This menu allows you to select the genlock source for the mainframe and the installed modules, set the timing offset, and the instrument actions when lock is lost. Use the up (▲) or down (▼) arrow button to scroll through the menu. Figure 2-2 shows the GENLOCK submenu.

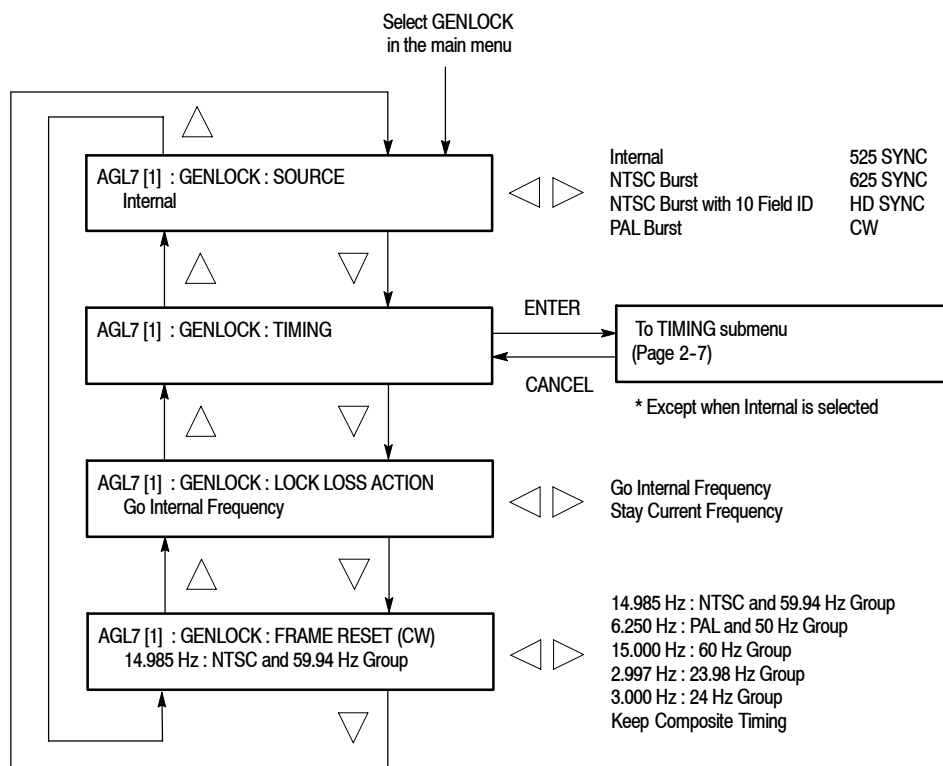

Figure 2-2: GENLOCK submenu

SOURCE. Selects the signal source to genlock the mainframe and the installed modules. Use the left (◀) or right (▶) arrow button to select the genlock source. The choices are:

- **Internal:** Uses the internal reference signal.
- **NTSC Burst:** Burst locks to an NTSC black burst signal applied to the REF connector.
- **NTSC Burst with 10 Field ID:** Burst locks to an NTSC black burst with 10 Field ID signal applied to the REF connector.
- **PAL Burst:** Burst locks to a PAL black burst signal applied to the REF connector.
- **525 SYNC:** Sync locks to an NTSC black burst signal applied to the REF connector.

- **625 SYNC:** Sync locks to a PAL black burst signal applied to the REF connector.
- **HD SYNC:** Locks to an HDTV trilevel signal applied to the REF connector.
- **CW:** Locks to 1, 3.58, 4.43, 5, and 10 MHz continuous wave signals applied to the CW connector.

Press the **ENTER** button to confirm the selection.

TIMING. Adjusts the timing offset of the input signal relative to the internal reference signal (frame reset signal). When you select this menu item and then press the **ENTER** button, you will access the **TIMING** submenu. Refer to *TIMING Submenu* on page 2-7 for detailed information.

LOCK LOSS ACTION. Sets the way the AGL7 will react when a loss of genlock state occurs (for example, genlock source is absent or incompatible). The selections are:

- **Go Internal Frequency:** When a loss of genlock state occurs, the instrument will automatically switch to the internal reference, and the EXT.REF indicator blinks.
- **Stay Current Frequency:** When a loss of genlock state occurs, the instrument will maintain the current state.

Press the **ENTER** button to confirm the selection.

FRAME RESET (CW). Selects the frame reset signal frequency to be used when a CW signal is applied to the CW connector. Use the left (◀) or right (▶) arrow button to select the frequency. The choices are:

- **14.985 Hz : NTSC and 59.94 Hz Group:** Uses a frame reset signal with a frequency of 14.985 Hz.
- **6.250 Hz : PAL and 50 Hz Group:** Uses a frame reset signal with a frequency of 6.250 Hz.
- **15.000 Hz : 60 Hz Group:** Uses a frame reset signal with a frequency of 15.000 Hz.
- **2.997 Hz : 23.98 Hz Group:** Uses a frame reset signal with a frequency of 2.997 Hz.
- **3.000 Hz : 24 Hz Group:** Uses a frame reset signal with a frequency of 3.000 Hz.

- Keep Composite Timing:** In this mode, even if you change the genlock source to CW while the instrument is genlocked to a NTSC or PAL black burst signal, synchronization shock is small (at this time, the instrument keeps the previously used timing of NTSC or PAL whenever possible). The frame frequency is the same as that of NTSC or PAL that was previously used. Use a 5 MHz, 10 MHz, 3.58 MHz (for NTSC), or 4.43 MHz (for PAL) signal as a CW signal source.

Press the **ENTER** button to confirm the selection.

OUTPUT Submenu

Use this submenu to set the signal format and the timing offset for the output selected in the SELECT OUTPUT menu. Use the up (▲) or down (▼) arrow button to change the menu items. Figure 2-3 shows the OUTPUT submenu.

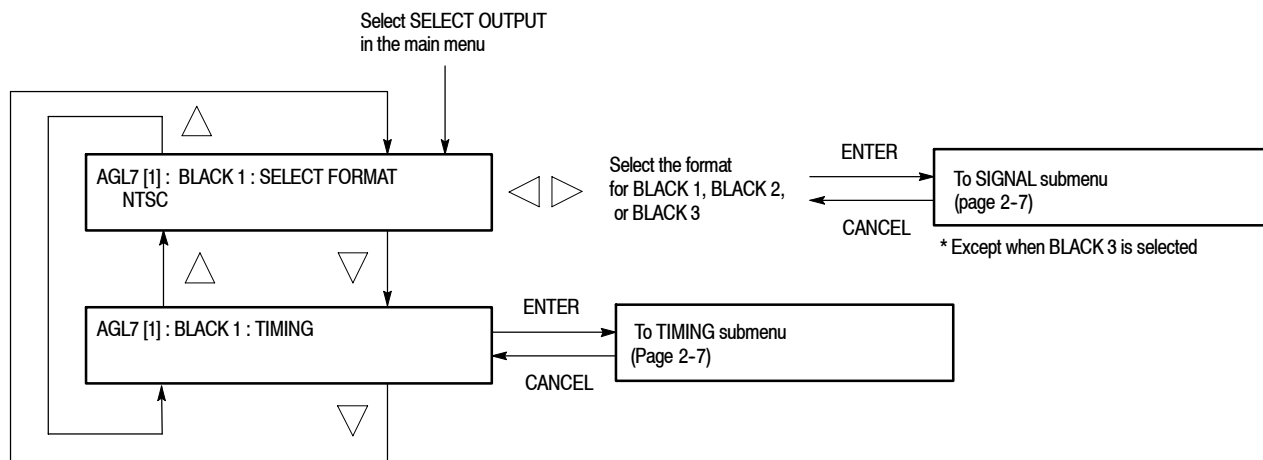

Figure 2-3: OUTPUT submenu

NOTE. When you change signal format, synchronization shock occurs.

SELECT FORMAT. Selects the format for the signal output from the BLACK 1, BLACK 2, or BLACK 3 connector. Use the left (◀) or right (▶) arrow button to select the format. The available choices depend on the selected output connector. The choices are:

- When **BLACK 1** is selected:
 - NTSC
 - NTSC No Setup
 - PAL

Press the **ENTER** button to confirm the selection. When you press the **ENTER** button, you will access the **SIGNAL** submenu to select a black burst signal. Refer to *SIGNAL Submenu* on page 2-7 for detailed information.

- When **BLACK 2** is selected:

NTSC

NTSC No Setup

PAL

HD SYNC (Same as BLACK 3)

Press the **ENTER** button to confirm the selection. When you press the **ENTER** button, you will access the **SIGNAL** submenu to select a black burst signal. Refer to *SIGNAL Submenu* on page 2-7 for detailed information.

- When **BLACK 3** is selected:

1080 60i

1080 59.94i

1080 50i

1080 24sF

1080 23.98sF

1080 30p

1080 29.97p

1080 25p

1080 24p

1080 23.98p

720 60p

720 59.94p

720 50p

Black Burst (Same as BLACK 2)

When you press the **ENTER** button, the selected trilevel sync signal or black burst signal (when Black Burst (Same as BLACK2) is selected) is enabled.

TIMING. Adjusts the timing offset for the output signals relative to the internal reference signal (frame reset signal). When you select this menu item and then

press the ENTER button, you can access the TIMING submenu. However, you cannot set the timing offset under the following conditions:

When HD SYNC (Same as BLACK 3) is selected as a format for the BLACK 2 output.

When BB (Same as BLACK 2) is selected as a format for the BLACK 2 output.

Refer to *TIMING Submenu* on page 2-7 for detailed information about the menu.

SIGNAL Submenu

This menu allows you to select the black burst signal for the NTSC, NTSC No Setup, and PAL formats. Figure 2-4 shows the SIGNAL submenu.

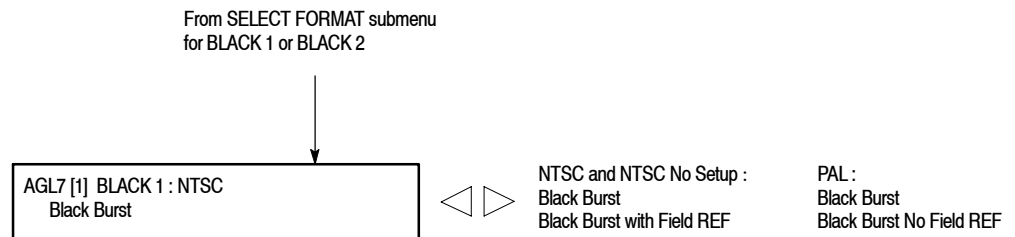

Figure 2-4: SIGNAL submenu

Use the left (◀) or right (▶) arrow button to select the black burst signal. The available selections vary, depending on the format selected.

- When the **NTSC** or **NTSC No Setup** format is selected:

Black Burst

Black Burst with Field REF

- When the **PAL** format is selected:

Black Burst

Black Burst with No Field REF

Press the **ENTER** button to confirm the selection.

TIMING Submenu

This menu allows you to adjust the timing offset of the input and output signals relative to the internal reference signal (frame reset signal). Use the up (▲) or down (▼) arrow button to scroll through the menu.

The TIMING submenu uses the same menu structure for both input and output signals, except for the menu items displayed in the first line. Figure 2-5 shows the TIMING submenu.

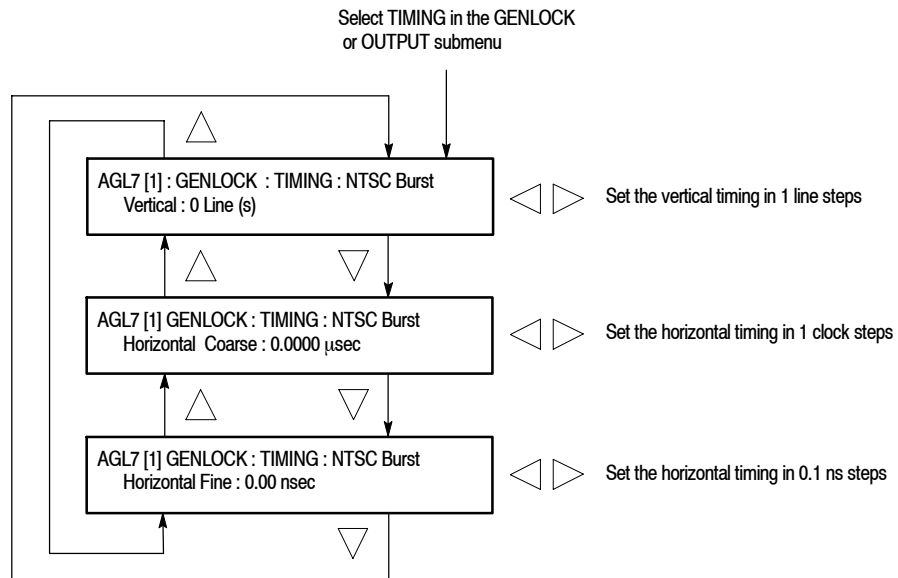

Figure 2- 5: TIMING submenu

- **Vertical:** Use the left (◀) or right (▶) arrow button to adjust the vertical offset. The range of the timing adjustment depends on the selected signal format. Refer to Table 2-1 and Table 2-2 for the appropriate range.
- **Horizontal Coarse:** Use the left (◀) or right (▶) arrow button to adjust the coarse horizontal offset. The range of the timing adjustment depends on the selected signal format. Refer to Table 2-1 and Table 2-2 for the appropriate range.
- **Horizontal Fine:** Use the left (◀) or right (▶) arrow button to adjust the fine horizontal offset. The range of the timing adjustment depends on the selected signal format. Refer to Table 2-1 and Table 2-2 for the appropriate range.

NOTE. You can reset the timing offset to zero by pressing the left (◀) and right (▶) arrow buttons simultaneously.

Table 2-1: Timing adjustment ranges for input signals

Format name	Line settings	Coarse settings (μ s)	Fine settings (ns)
NTSC	± 525	± 63.5556	± 10.00
PAL	± 1250	± 64.0000	± 10.00
1080 60i	± 562	± 29.6296	± 10.00
1080 59.94i	± 562	± 29.6593	± 10.00
1080 50i	± 562	± 35.5556	± 10.00
1080 24sF	± 562	± 37.0370	± 10.00
1080 23.98sF	± 562	± 37.0741	± 10.00
1080 30p	± 562	± 29.6296	± 10.00
1080 29.97p	± 562	± 29.6593	± 10.00
1080 25p	± 562	± 35.5556	± 10.00
1080 24p	± 562	± 37.0370	± 10.00
1080 23.98p	± 562	± 37.0741	± 10.00
720 60p	± 375	± 22.2222	± 10.00
720 59.94p	± 375	± 22.2444	± 10.00

Table 2-2: Timing adjustment ranges for output signals

Format name	Line settings	Coarse settings (μ s)	Fine settings (ns)
NTSC	± 525	± 63.5556	± 10.00
PAL	± 1250	± 64.0000	± 10.00
1080 60i	± 562	± 29.6296	± 7.00
1080 59.94i	± 562	± 29.6593	± 7.00
1080 50i	± 562	± 35.5556	± 7.00
1080 24sF	± 562	± 37.0370	± 7.00
1080 23.98sF	± 562	± 37.0741	± 7.00
1080 30p	± 562	± 29.6296	± 7.00
1080 29.97p	± 562	± 29.6593	± 7.00
1080 25p	± 562	± 35.5556	± 7.00
1080 24p	± 562	± 37.0370	± 7.00
1080 23.98p	± 562	± 37.0741	± 7.00
720 60p	± 375	± 22.2222	± 7.00
720 59.94p	± 375	± 22.4444	± 7.00

Rear-Panel Connectors

The AGL7 Genlock module is equipped with the REF input connectors, the CW input connector, and three black signal output connectors : BLACK1, BLACK 2, BLACK 3. Figure 2-6 shows the AGL7 Genlock module rear-panel connectors.

NOTE. You cannot output HDTV trilevel sync signals from the BLACK 1 connector.

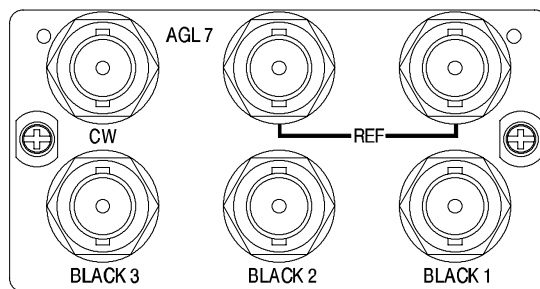

Figure 2-6: AGL7 module rear-panel connectors

- **REF:** Loophrough connectors for an external reference signal. These inputs accept NTSC/PAL black burst signals and HDTV trilevel sync signal. The inputs require proper termination at one end of the connector.
- **CW:** Input connector for CW (Continuous Wave) signals: 1, 3.58, 4.43, 5, and 10 MHz. This connector is internally terminated.

You can output a 48 kHz word clock signal from the connector. Refer to *Changing the Input/Output Configuration* on page 2-11.

- **BLACK 1:** Black burst signal output.
- **BLACK 2:** Black burst signal and HDTV trilevel sync signal output.
- **BLACK 3:** Black burst signal and HDTV trilevel sync signal output.

Changing the Input/Output Configuration

The CW connector can be configured to output a 48 kHz word clock signal by changing internal cabling.



CAUTION. To prevent damage to the mainframe and the module, be sure to disconnect the power cord before removing the module.

To output a word clock signal from the connector:

1. Disconnect the coaxial cable from the connector labeled **J040** on the circuit board. See Figure 2-7.
2. Reconnect the cable to the connector labeled **J960** on the circuit board. See Figure 2-7.

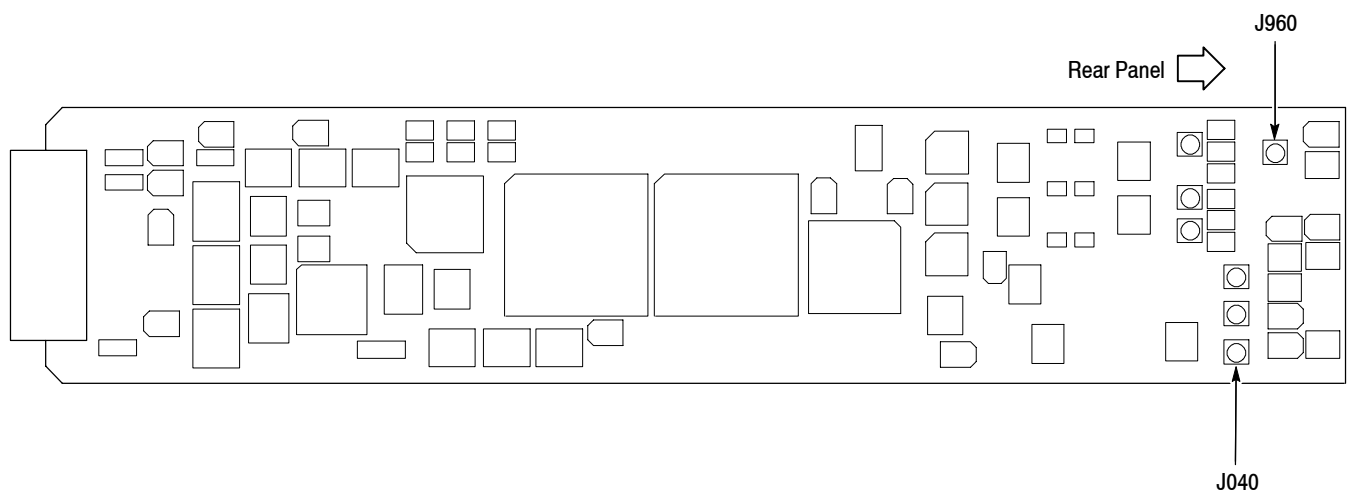

Figure 2-7: Location of the J040 and J960 connectors

3. Place the **48 kHz CLOCK** label provided with the instrument on the rear panel below the CW connector.

NOTE. The word clock signal automatically follows the format of the Black 1 signal.

Factory Default Settings

Table 2-3 shows the factory default settings of the AGL7 Genlock module. These settings are recalled when you select **Factory Default** from the **PRESET : RECALL** menu item in the mainframe main menu.

Table 2-3: Factory default settings

Menu item name	Settings
GENLOCK : SOURCE	Internal
GENLOCK : TIMING	
Vertical	0 Line(s)
Horizontal Coarse	0.0000 μ s
Horizontal Fine	0.00 nsec
GENLOCK : LOCK LOSS ACTION	Go Internal Frequency
GENLOCK : FRAME RESET (CW)	14.985 Hz : NTSC and 59.94 Hz Group
OUTPUT : BLACK 1	
FORMAT	NTSC
SIGNAL	Black Burst
OUTPUT : BLACK 2	
FORMAT	NTSC
SIGNAL	Black Burst
OUTPUT : BLACK 3	
FORMAT	1080 59.94i
SIGNAL	Tri Level Sync
BLACK x : TIMING	
Vertical	0 Line(s)
Horizontal Coarse	0.0000 μ s
Horizontal Fine	0.00 nsec



Reference

Syntax

This section contains information on the Standard Commands for Programmable Instruments (SCPI) and the programming structure you can use to program your AGL7 Genlock module.

Programming Model

Specific conditions must exist before programming commands will affect the test signal generated by a module.

Selecting the Module

Select the module using the `:INSTRument:SElect` command before executing any commands. Many of the commands used by the AGL7 module are shared by several modules and will be accepted without a reported error.

Command Arguments

Many commands will accept either string or numeric arguments. For example: a boolean argument can either be "1" or "ON".

Signal parameter commands that have a `:STEP` node can accept either a numeric value or they can accept a string argument that refers to the `:STEP` increment.

Signal parameter commands with a `:STEP` node will accept the following strings in addition to a numeric value:

UP. Use this argument to increase the parameter value one increment as defined by the `:STEP` value.

DOWN. Use this argument to decrease the parameter value one increment as defined by the `:STEP` value.

MINimum. Use this argument to set the parameter value to the minimum acceptable value.

MAXimum. Use this argument to set the parameter value to the maximum acceptable value.

DEFault. Use this argument to set the parameter value to the default value.

Query Arguments

If you send a query with no argument, the response is the current value. You can also use **MINimum**, **MAXimum**, and **DEFault** as arguments for queries whose command form can use these arguments (refer to the command syntax for the specific command). Instead of returning the current value, queries using these arguments return the following information:

MINimum. Return the minimum acceptable value.

MAXimum. Return the maximum acceptable value.

DEFault. Return the default value.

Argument Example

The following example demonstrates the effect of each of the arguments when used with a step value.

1. `:INSTRument:SElect "HDVG7:#"` selects the digital video generator module located in the slot number indicated by the “#” symbol.
2. `:OUTPut:CIRClE:STATe ON` displays a circle on the video display.

NOTE. `:OUTPut:CIRClE:DIAMeter` uses an argument that is the percent of picture height.

3. `:OUTPut:CIRClE:DIAMeter DEFaul t` sets the circle diameter to 90 percent of the screen height.
4. `:OUTPut:CIRClE:DIAMeter:STEP 10` sets the step increment to 10 percent.
5. `:OUTPut:CIRClE:DIAMeter DOWN` changes the circle diameter to 80 percent of the screen height.
6. `:OUTPut:CIRClE:DIAMeter 50` changes the circle diameter to 50 percent of the screen height.
7. `:OUTPut:CIRClE:DIAMeter MAXimum` changes the circle diameter to 100 percent of the screen height.
8. `:OUTPut:CIRClE:DIAMeter MINimum` changes the circle diameter to 0 percent of the screen height.
9. `:OUTPut:CIRClE:DIAMeter UP` changes the circle diameter to 10 percent of the screen height.
10. `:OUTPut:CIRClE:DIAMeter? MAXimum` queries the maximum circle diameter (not the current diameter). The query returns the value of 100 percent, which is the maximum circle diameter allowable.

SCPI Commands and Queries

SCPI is a standard created by a consortium that provides guidelines for remote programming of instruments. These guidelines provide a consistent programming environment for instrument control and data transfer. This environment uses defined programming messages, instrument responses, and data format across all SCPI instruments, regardless of manufacturer. The AGL7 Genlock module uses a command language based on the SCPI standard.

The SCPI language is based on a hierarchical or tree structure (see Figure 3-1) that represents a subsystem. The top level of the tree is the root node; it is followed by one or more lower-level nodes.

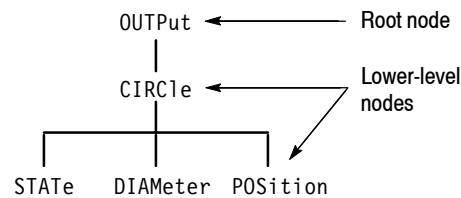

Figure 3-1: Example of SCPI subsystem hierarchy

You can create commands and queries from these subsystem hierarchy trees. Commands specify actions for the instrument to perform. Queries return measurement data and information about parameter settings.

For more information on SCPI commands and programming structure, refer to the *TG700 Signal Generator Platform User Manual*.

Remote Commands

This section describes the commands used for the AGL7 Genlock module remote operation. The commands for the module are divided into the following four groups:

- INPUT commands
- SOURCE commands
- OUTPUT commands
- SENSE commands

INPUT Commands

Use these commands to set the input standard and input connector for the genlock signal.

Command Tree

:INPut	
:REFeRence	
:STANdard	NBURst PBURst N318M NSYNc PSYNc HDSYNc
:STATus?	
:HDSYNc?	
:SELeCt	REFeRence CW
:SOURce	INTeRnal EXTeRnal
:CWAVE	
:FRAMe	2.997 3.0 6.25 14.985 15.0 0
:FREQuency?	
:LLOs:ACTion	INTeRnal STAY

Command Description

:INPut:REFeRence:STANdard NBURst | PBURst | N318M | NSYNc | PSYNc | HDSYNc

Selects the input standard expected at the REF connector. The choices are NBURst (burst lock to NTSC black burst), PBURst (burst lock to PAL black burst), N318M (burst lock to NTSC black burst with 10 field ID), NSYNc (sync lock to NTSC black burst), PSYNc (sync lock to PAL black burst), and HDSYNc (lock to HDTV trilevel sync).

:INPut:REFeRence:STANdard?

Returns the current input standard.

:INPut:REFeRence:STATus?

Returns the current genlock status. The available responses are INTERNAL, ABSent, UNLOCKed, or LOCKed.

:INPut:REFeRence:HDSYnc?

Returns the format of the HDTV trilevel sync signal currently inputted. The available responses are HD1080_60I, HD1080_59I, HD1080_50I, HD1080_24SF, HD1080_23SF, HD1080_30P, HD1080_29P, HD1080_25P, HD1080_24P, HD1080_23P, HD720_60P, or HD720_59P.

:INPut:SElect REF|CW

Sets the reference input for the genlock source. For REF, a black burst signal or HDTV trilevel signal applied to the REF connector is used. For CW, a CW signal applied to the CW connector is used for the genlock source.

:INPut:SElect?

Returns the reference input currently used.

:INPut:SOURce INTernal|EXTernal

Determines whether the internal signal or external signal is used as a reference signal.

:INPut:SOURce?

Returns the signal source (internal or external) used as a reference signal.

:INPut:CWAVe:FRAMe 2.997|3.0|6.25|14.985|15.0|0

Sets the frame reset signal frequency used when a CW signal is applied to the CW connector. The choices are 2.997 Hz, 3.0 Hz, 6.25 Hz, 14.985 Hz, and 15.0 Hz. For 0, the instrument is set to Keep Composite Timing. For detailed information about Keep Composite Timing, refer to page 2-5.

:INPut:CWAVe:FRAMe?

Returns the current frequency of the frame reset signal for the CW input.

:INPut:CWAVE:FREQuency?

Returns the frequency of the CW signal currently applied. The available responses are 1.0, 3.58, 4.43, 5.0, or 10.0.

:INPut:LLOs:ACTion INTernal|STAY

Sets the instrument action when a loss of genlock state occurs. For INTernal, the instrument automatically switches to the internal reference. For STAY, the instrument maintains the current state.

:INPut:LLOs:ACTion?

Returns the current instrument action when a loss of genlock state occurs. The available responses are INT or STA.

SOURCE Commands

Use these commands to set the timing offset of the genlock input signal relative to the internal reference signal (frame reset signal).

Refer to *Operating Basics* for detailed information about the setting range.

Command Tree

```

:SOURce
:CORRection
:MDELay
:HORizontal <numeric_value>
:STEP <numeric_value>
:VERTical <numeric_value>
:STEP <numeric_value>

```

Command Description

:SOURce:CORRection:MDELay:HORizontal <numeric_value>

Sets the horizontal timing offset of the genlock input signal relative to the internal reference signal. The units are microseconds. You can use UP, DOWN, or DEF instead of a numeric value.

:SOURce:CORRection:MDELay:HORizontal?

Returns the horizontal timing offset of the genlock input signal.

:SOURce:CORRection:MDElay:HORizontal:STEP <numeric_value>

Sets the step increment used by the UP or DOWN command. The units are microseconds. You can use MIN, MAX, or DEF instead of a numeric value.

:SOURce:CORRection:MDElay:HORizontal:STEP?

Returns the step increment used by the UP or DOWN command.

:SOURce:CORRection:MDElay:VERTical <numeric_value>

Sets the vertical timing offset of the genlock input signal relative to the internal reference signal. The units are line numbers. You can use UP, DOWN, or DEF instead of a numeric value.

:SOURce:CORRection:MDElay:VERTical?

Returns the vertical timing offset of the genlock input signal.

:SOURce:CORRection:MDElay:VERTical:STEP <numeric_value>

Sets the step increment used by the UP or DOWN command. The units are line numbers. You can use MIN, MAX, or DEF instead of a numeric value.

:SOURce:CORRection:MDElay:VERTical:STEP?

Returns the step increment used by the UP or DOWN command.

OUTPUT Commands

Use these commands to set the video standard and the type of signal for the BLACK outputs.

Command Tree

```
:OUTPut1
  :STANdard          NTSC|PAL|NTSC_NSU
:OUTPut2
  :STANdard          NTSC|PAL|NTSC_NS|HDSYnc
:OUTPut3
  :STANdard          BB|HD1080_60I|HD1080_59I|HD1080_50I|
                    HD1080_24SF|HD1080_30P|HD1080_29P|
                    HD1080_25P|HD1080_24P|HD1080_23P|
                    HD720_60P|HD720_59P|HD720_50P
:OUTPUT<n>
  :SIGNal           BB|BB_FREF|BB_NO_FREE
```

Command Description

`:OUTPut1:STANdard NTSC|PAL|NTSC_NSU`

Sets the video standard for the BLACK 1 output. The choices are NTSC, PAL, and NTSC_NSU (NTSC no setup).

`:OUTPut1:STANdard?`

Returns the video standard for the BLACK 1 output.

`:OUTPut2:STANdard NTSC|PAL|NTSC_NSU|HDSYnc`

Sets the video standard for the BLACK 2 output. The choices are NTSC, PAL, NTSC_NSU (NTSC no setup), and HDSYnc (HDTV trilevel sync).

`:OUTPut2:STANdard?`

Returns the video standard for the BLACK 2 output.

`:OUTPut3:STANdard BB|HD1080_60I|HD1080_59I|HD1080_50I|
HD1080_24SF|HD1080_30P|HD1080_29P|
HD1080_25P|HD1080_24P|HD1080_23P|
HD720_60P|HD720_59P|HD720_50P`

Sets the video standard for the BLACK 3 output. The choices are BB (black burst) and HD1080_60I to HD720_50P.

`:OUTPut3:STANdard?`

Returns the video standard for the BLACK 3 output.

`:OUTPut<n>:SIGNa1 BB|BB_FREF|BB_NO_FREF`

Sets what kind of signal is available from a specific BLACK output. The <n> in the command represents the connector number. You can use connector number 1 and 2.

If the standard is NTSC or NTSC_NSU, the options are BB (black burst) or BB_FREF (black burst with field reference).

If the standard is PAL, the options are BB (black burst) or BB_NO_FREF (black burst no field reference).

`:OUTPut<n>:SIGNa1?`

Returns the current output signal. The <n> in the command represents the connector number. You can use connector number 1 and 2.

SENSE Commands

Use these commands to set the timing offset of the BLACK outputs relative to the internal reference signal (frame reset signal).

Refer to *Operating Basics* for detailed information about the setting range.

Command Tree

```
:SENSe<n>
  :CORRection
    :MDElay
      :HORizontal    <numeric_value>
        :STEP        <numeric_value>
      :VERTical      <numeric_value>
        :STEP        <numeric_value>
```

Command Description

`:SENSe<n>:CORRection:MDElay:HORizontal <numeric_value>`

Sets the horizontal timing offset of a specific BLACK output. The units are microseconds. You can use UP, DOWN, or DEF instead of a numeric value. If the argument exceeds the horizontal time value, then the vertical offset is adjusted to accommodate the requested offset. The <n> in the command represents the connector number. You can use any connector number from 1 through 3.

`:SENSe<n>:CORRection:MDElay:HORizontal?`

Returns the horizontal timing offset of a specific BLACK output. The <n> in the command represents the connector number. You can use any connector number from 1 through 3.

`:SENSe<n>:CORRection:MDElay:HORizontal:STEP <numeric_value>`

Sets the step increment used by the UP or DOWN command. The units are microseconds. You can use MIN, MAX, or DEF instead of a numeric value. The <n> in the command represents the connector number. You can use any connector number from 1 through 3.

`:SENSe<n>:CORRection:MDElay:HORizontal:STEP?`

Returns the step increment used by the UP or DOWN command. The <n> in the command represents the connector number. You can use any connector number from 1 through 3.

:SENSe<n>:CORRection:MDELay:VERTical <numeric_value>

Sets the vertical timing offset of a specific BLACK output. The units are horizontal lines. You can use UP, DOWN, or DEF instead of a numeric value. The <n> in the command represents the connector number. You can use any connector number from 1 through 3.

:SENSe<n>:CORRection:MDELay:VERTical?

Returns the vertical timing offset of a specific BLACK output. The <n> in the command represents the connector number. You can use any connector number from 1 through 3.

:SENSe<n>:CORRection:MDELay:VERTical:STEP <numeric_value>

Sets the step increment used by the UP or DOWN commands. The units are horizontal lines. You can use MIN, MAX, or DEF instead of a numeric value. The <n> in the command represents the connector number. You can use any connector number from 1 through 3.

:SENSe<n>:CORRection:MDELay:VERTical:STEP?

Returns the step increment used by the UP or DOWN commands. The <n> in the command represents the connector number. You can use any connector number from 1 through 3.



Appendices

Appendix A: Specifications

Tables A-1 through A-4 list the electrical and environmental characteristics of the AGL7 Genlock module.

Electrical Characteristics

Table A- 1: Genlock function

Characteristic	Performance requirements	Reference information
Input configuration	75 Ω loop through 75 Ω terminated	REF inputs CW input
Return loss	> 40 dB > 35 dB	5 MHz 5 MHz to 30 MHz
Input requirements		
Reference inputs	NTSC/PAL black burst or Trilevel sync	
Amplitude	± 6 dB	
S/N ratio	> 40 dB	
SCH phase	$\pm 40^\circ$	
CW input	1, 3.58, 4.43, 5, or 10 MHz CW	The CW input connector can be configured to output a 48 kHz word clock signal by changing internal cabling.
Input range	1 to 2.5 Vp-p	
Pull-in range	Subcarrier frequency ± 15 Hz	
Jitter		
Burst lock	< 0.5°	
Sync lock	< 1 ns	

Table A-2: Black burst signal and HDTV trilevel sync signal outputs

Characteristic	Performance requirements	Reference information
Connector	BNC	
Number of outputs	3	BLACK1, BLACK2, and BLACK3
Configuration		
BLACK1	Black burst	BLACK1 always generates Black burst.
BLACK2	Black burst or Trilevel sync	When the trilevel sync signal is selected, the signal to be the same signal as BLACK 3 is output.
BLACK3	Black burst or Trilevel sync	When the black burst is selected, the signal to be the same signal as BLACK 2 is output.
Burst amplitude accuracy	$\pm 2\%$	
Sync amplitude accuracy	$\pm 2\%$	
Sync rise time		
NTSC		140 ns
PAL		250 ns
Return loss	> 30 dB to 30 MHz	
Timing offset		
Range	Full color frame	
Resolution	$< 0.5^\circ$ of sub carrier	

Table A-3: Word clock signal output*

Characteristic	Performance requirements	Reference information
Connector	BNC	Same connector as CW
Frequency	48 kHz	
Level	CMOS compatible	Without termination
Impedance	$75 \Omega \pm 10\%$	

* This output is enabled when the configuration of the CW connector is changed.

Environmental Characteristics

Table A- 4: Environmental characteristics

Characteristic	Description
Temperature	
Operating	0 °C to +50 °C
Non-operating	-20 °C to +60 °C
Relative Humidity	
Operating	20% to 80% (No condensation) ; Maximum wet-bulb temperature 29.4 °C
Non-operating	5% to 90% (No condensation) ; Maximum wet-bulb temperature 40.0 °C
Altitude	
Operating	To 4.5 km (15,000 feet) Maximum operating temperature decreases 1 °C each 300 m above 1.5 km.
Non-operating	To 15 km (50,000 feet)
Vibration	
Operating	3.04 m/s ² (0.31 G _{rms}), 5 Hz to 500 Hz, 10 min, three axes
Non-operating	23.3 m/s ² (2.38 G _{rms}), 5 Hz to 500 Hz, 10 min, three axes
Shock	
Non-operating	294 m/s ² (30 G), half-sine, 11 ms duration



Index

Index

A

- Accessories
 - optional, 1-2
 - standard, 1-2
- AGL7 features, 1-1
- AGL7 module main menu, 2-2
 - GENLOCK, 2-2
 - SELECT OUTPUT, 2-2
 - STATUS, 2-2

B

- BLACK 1 connector, 2-10
- BLACK 2 connector, 2-10
- BLACK 3 connector, 2-10

C

- Commands
 - Rules for forming, 3-1
 - Syntax, 3-1
- CW connector, 2-10

E

- Electrical specifications, A-1
- Environmental specifications, A-3

F

- Factory default settings, 2-11
- Functional check, 1-2
- Functional command groups, 3-5

G

- GENLOCK submenu, 2-3

H

- Hierarchy (SCPI), 3-3

I

- INPUT commands, 3-5

- Installation, 1-2

M

- Manuals, Related, iii

O

- Operating procedure, 2-1
- Option, 1-2
- Optional accessories, 1-2
- OUTPUT commands, 3-8
- OUTPUT submenu, 2-5

P

- Product description, 1-1

R

- Rear-panel connectors, 2-10
- REF connector, 2-10
- Related Manuals, iii
- Rules, Command forming, 3-1

S

- SCPI, Subsystem hierarchy tree, 3-3
- SCPI commands and queries syntax, 3-3-3-4
- SENSE commands, 3-10
- SIGNAL submenu, 2-7
- SOURCE commands, 3-7
- Specifications
 - Electrical, A-1
 - Environmental, A-3
- Standard accessories, 1-2
- Syntax, Command, 3-1

T

- TIMING submenu, 2-7

User Manual



ATG7 Analog Test Generator

Copyright © Tektronix. All rights reserved. Licensed software products are owned by Tektronix or its suppliers and are protected by United States copyright laws and international treaty provisions.

Tektronix products are covered by U.S. and foreign patents, issued and pending. Information in this publication supercedes that in all previously published material. Specifications and price change privileges reserved.

TEKTRONIX and TEK are registered trademarks of Tektronix, Inc.

Contacting Tektronix

Tektronix, Inc.
14200 SW Karl Braun Drive
P.O. Box 500
Beaverton, OR 97077
USA

For product information, sales, service, and technical support:

- In North America, call 1-800-833-9200.
- Worldwide, visit www.tektronix.com to find contacts in your area.

Table of Contents

Preface	iii
About This Manual	iii
Related Manuals	iii
Getting Started	
Product Description	1-1
Accessories	1-2
Option	1-2
Installation	1-2
Functional Check	1-3
Operating Basics	
Operating Procedure	2-1
Selecting an Output Signal	2-2
ATG7 Module Main Menu	2-5
Rear-Panel Connectors	2-13
Factory Default Settings	2-13
Reference	
Syntax	3-1
Programming Model	3-1
SCPI Commands and Queries	3-3
Remote Commands	3-5
MASS MEMORY Commands	3-5
OUTPUT Commands	3-6
SENSE Commands	3-10
Appendices	
Appendix A: Specifications	A-1
Electrical Characteristics	A-1
Environmental Characteristics	A-4
Index	

List of Figures

Figure 2-1: Front-panel test signal buttons	2-3
Figure 2-2: ATG7 module main menu	2-5
Figure 2-3: SELECT OUTPUT submenu	2-7
Figure 2-4: SELECT SIGNAL submenu	2-8
Figure 2-5: ID TEXT submenu	2-9
Figure 2-6: TIMING submenu	2-11
Figure 2-7: APL submenu	2-12
Figure 2-8: ATG7 module rear-panel connectors	2-13
Figure 3-1: Example of SCPI subsystem hierarchy	3-3

List of Tables

Table 1-1: Standard and optional accessories	1-2
Table 2-1: Signal set assigned to the test signal buttons	2-3
Table 2-2: Selectable signals in the SELECT SIGNAL submenu ..	2-8
Table 2-3: Factory default settings	2-13
Table A-1: Black burst and timing pulse outputs	A-1
Table A-2: Color bars signal output	A-2
Table A-3: Test signal output	A-3
Table A-4: Common outputs characteristics	A-3
Table A-5: Environmental characteristics	A-4

Preface

This manual documents the capabilities, operation, and specifications of the ATG7 Analog Test Generator module.

About This Manual

This manual is composed of the following sections:

- *Getting Started* contains product description and functional check procedure.
- *Operating Basics* explains how to operate the ATG7 module using the menus and front-panel buttons.
- *Reference* provides the syntax used in command descriptions and describes all programming commands.
- *Appendices* provides the specifications.

Related Manuals

The following documents are also available:

- The *TG700 TV Signal Generator Platform Service Manual* (Tektronix part number 070-A800-XX) describes how to maintain and service the mainframe and generator modules. This manual is an optional accessory.
- The *TG700 TV Signal Generator Platform Module Installation Instructions* (Tektronix part number 070-A824-XX) describes how to install and remove the modules, and how to upgrade the firmware of the mainframe.



Getting Started

Getting Started

This section contains the following information:

- Product description
- Accessories
- Option
- Installation
- Functional check

Product Description

The ATG7 Analog Test Generator module is designed to be installed in the TG700 TV Signal Generator Platform.

The module is an analog test signal generator which provides NTSC/PAL analog composite signals. PAL-M and PAL-N are not supported by the AGL7, ATG7 and BG7 modules. The ATG7 Generator module contains the following features:

- SIGNAL output:
 - Outputs test signals selectable from the front-panel test signal buttons
 - Overlay ID text on the video signal
- BARS output:
 - Outputs NTSC (with or without setup) /PAL color bars signals, black burst signals, and other test signals (Other 1 and Other 2)
 - Overlay ID text on the video signal
- BLACK 1 and BLACK 2 outputs:
 - Outputs NTSC (with or without setup)/PAL black burst signals, composite sync signal, composite blanking signal, NTSC (with or without setup)/PAL subcarrier signals, H/V drive signals, color frame ID signal, and PAL pulse signal
- Individual format and timing control for each output
- Full remote control using Ethernet interface

Accessories

Table 1-1 lists the standard and optional accessories provided with the ATG7 Generator module.

Table 1-1: Standard and optional accessories

Accessory	Std.	Opt.	Tektronix part number
TG700 TV Signal Generator Platform Module Installation Instructions	•		070-A824-XX
TG700 Signal Generator Platform Software Library CD-ROM	•		062-A249-XX
TG700 TV Signal Generator Platform Service Manual		•	070-A800-XX

Option

This subsection describes the option available for the ATG7 Generator module. The following option is available:

Option D1 (Test data report)

Option D1 (Test Data Report)

A calibration test data report will be provided with the ATG7 Generator module when this option is specified.

Installation

Refer to the *TG700 TV Signal Generator Platform Module Installation Instructions* for instructions on how to install the ATG7 Generator module.

NOTE. *If the firmware version of your TG700 mainframe is 1.3 or earlier, you need to upgrade the firmware of the mainframe before using the ATG7 module. Refer to the TG700 TV Signal Generator Platform Module Installation Instructions for the procedures.*

Functional Check

The following procedure determines whether the module is operating correctly.

Required equipment

The following equipment is required for the functional check:

- NTSC/PAL waveform monitor
- 75 Ω BNC cable
- 75 Ω terminator

Procedure

1. Install the module into the TG700 Platform mainframe using the installation procedures described in the *TG700 TV Signal Generator Platform User Manual*.
2. Power on the TG700 TV Signal Generator Platform by connecting it to the power source. The initializing process for all installed modules is executed.
3. Check that no error messages appear on the display.
4. Warm up the instrument for 20 minutes.

SIGNAL Output :

5. Use the 75 Ω BNC cable to connect the **SIGNAL** connector to one of the input connectors on the waveform monitor rear panel.
6. Use the 75 Ω terminator to terminate the other loop through connector on the waveform monitor rear panel.
7. Press the front-panel **MODULE** button until the ATG7 main menu shown below appears.

ATG7 [x] : STATUS : NTSC No Setup
SMPTE Color Bars

8. Press the front-panel **FORMAT** button.
9. Press the left (◀) or right (▶) arrow button to select **NTSC** or **PAL**.
10. Press one of the front-panel test signal buttons (for example **COLOR BAR**) to output a signal.
11. Set the waveform monitor to view the signal.

12. Check that the signal appears as expected. For example, if you selected a color bars signal in step 10, check that the color bars signal appears.

BLACK 1 and BLACK 2 Outputs :

13. Disconnect the BNC cable from the **SIGNAL** connector, and then connect it to the **BLACK 1** connector.
14. Press the up (▲) or down (▼) arrow button to select **SELECT OUTPUT** from the main menu.
15. Press the left (◀) or right (▶) arrow button to select **BLACK 1**.
16. Press the front-panel **ENTER** button. The **SELECT FORMAT** submenu shown below appears.

```
ATG7 [x] : BLACK 1 : SELECT FORMAT
NTSC
```

17. Press the left (◀) or right (▶) arrow button to select **NTSC** or **PAL**.
18. Press the **ENTER** button. The **SELECT SIGNAL** submenu shown below appears.

```
ATG7 [x] : BLACK 1 : SELECT SIGNAL
Black Burst
```

19. Press the left (◀) or right (▶) arrow button to select **Black Burst**. Press the **ENTER** button to enable the selection.
20. Set the waveform monitor to view the blanking area of the signal.
21. Check that the appropriate black burst signal is displayed.
22. Move the BNC cable from the **BLACK 1** connector to the **BLACK 2** connector.
23. Press the front-panel **CANCEL** button twice to return to the main menu.
24. Repeat steps 15 through 21 to check the **BLACK 2** output.

BARS Output

25. Move the BNC cable from the **BLACK2** connector to the **BARS** connector.
26. Press the **CANCEL** button twice to return to the main menu.

27. Press the left (◀) or right (▶) arrow button to select **BARS**.
28. Press the **ENTER** button. The SELECT FORMAT submenu appears.
29. Press the left (◀) or right (▶) arrow button to select **NTSC** or **PAL**.
30. Press the **ENTER** button. The SELECT SIGNAL submenu appears.
31. Press the left (◀) or right (▶) arrow button to select **100 % Color Bars**.
Press the **ENTER** button to enable the selection.
32. Set the waveform monitor to view the color bars signal.
33. Check that the appropriate color bars signal appears.



Operating Basics

Operating Basics

This section explains how to operate the ATG7 Generator module using the front-panel buttons and menu. There is also a description of the rear-panel output connectors.

Refer to the *TG700 TV Signal Generator Platform User Manual* for a detailed explanation of the front-panel buttons and LCD display.

Operating Procedure

After the module is installed in the mainframe, and the mainframe is installed in the rack or other location where it will be used, access each function of the module with the following procedure:

1. Connect the power connector on the rear panel and AC electric power source using the power cord.

Electric power is supplied to the mainframe.

2. Wait until the power up initialization process is complete, and check that there are no error messages on the display.
3. After the initialization process is complete, the mainframe main menu appears, as shown below.



TG700: PRESET

4. Press the front-panel **MODULE** button until the ATG7 module main menu shown below appears.



ATG7 [x]: STATUS: NTSC
SMPTE Color Bars

5. Select the signal format and signal you want to output from the SIGNAL connector. Refer to *Selecting an Output Signal* on page 2-2 for more information.
6. Use the main menu or submenu item to select the signal format and signal you want to output from the BLACK 1, BLACK 2, and BARS connectors, and set all the other output parameters.

Refer to *ATG7 Module Main Menu* beginning on page 2-5 for detailed information about the main menu and the submenu items.

Selecting an Output Signal

The ATG7 Generator module provides the capability to output test signals assigned to the corresponding test signal buttons (see Figure 2-1) from the SIGNAL connector. When you output a signal from the connector, you need to select a signal format and output signal. This subsection provides instructions on how to output a signal.

Selecting a Format

If you press the front-panel **FORMAT** button when the ATG7 Generator module is selected (active), you can select the format for the output signals.

Perform the following steps to select the format:

1. Confirm that any of the menu items of the ATG7 module main menu is displayed. If the menu is not displayed, press the front-panel **MODULE** button until the ATG7 module main menu appears, as shown below.



ATG7 [x]: STATUS : NTSC
SMPTE Color Bars

2. Press the **FORMAT** button. The menu display changes as follows:

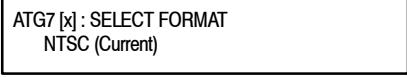

ATG7 [x]: SELECT FORMAT
NTSC (Current)

3. Press the left (◀) or right (▶) arrow button, or press the **FORMAT** button repeatedly to select one of the signal formats, and then press the **ENTER** button to confirm the selection.

NOTE. When you change signal format, synchronization shock occurs.

Selecting a Signal

Since all the signal sets available in the module are already assigned to corresponding test signal buttons (see Figure 2-1), when you press any of the buttons one of the signals in the signal set is output.

For example, when you press the **COLOR BAR** test signal button, you can output the **100% Color Bars** signal in the Color Bars signal set.

Press the left (◀) or right (▶) arrow button, or press the test signal button repeatedly to select different signals assigned to the test signal button.

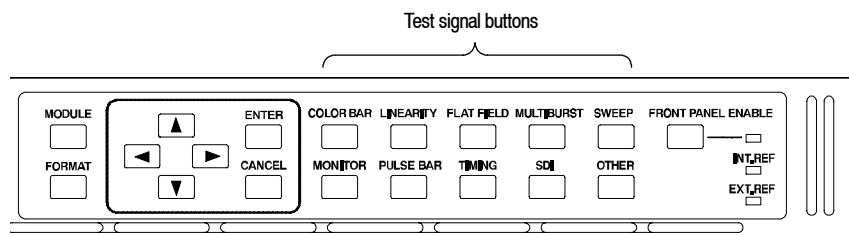

Figure 2-1: Front-panel test signal buttons

Table 2-1 lists the signal sets assigned to the test signal buttons, and shows the signals available in each signal set. The list of available signals changes, depending on the signal format.

Table 2-1: Signal set assigned to the test signal buttons

Button name	Signal set	Signals in the signal set
NTSC and NTSC No Setup formats		
COLOR BAR	Color Bars	100% Color Bars, 75% Color Bars, SMPTE Color Bars
LINEARITY	Linearity	5 Step, 10 Step, Modulated 5 Step, Modulated Pedestal, Modulated Ramp, Ramp, Shallow Ramp
FLAT FIELD	Flat Fields	0% Flat Field (NTSC format only), 10% Flat Field, 40% Flat Field, 50% Flat Field, 100% Flat Field, Field Square Wave, Black Burst, Black Burst with Field Ref
MULTIBURST	Multiburst	100% Multiburst, 60% Multiburst, Multipulse
SWEEP	Sweep	100% Sweep, 60% Sweep, Chroma Frequency Response
MONITOR	Monitor	100% Red Field, 75% Red Field, 2 Level Pedestal & Pluge, 4 Level Pedestal & Pluge, Convergence Pattern, Grey Window, White Window, Safe Area, Monitor Setup
PULSE BAR	Pulse & Bar	Window 2T Pulse & Bar, Sin X/X
OTHER	Other	FCC Composite, FCC Multiburst, NTC7 Combination, NTC7 Composite, Matrix 1, SNG Color Bars

Table 2- 1: Signal set assigned to the test signal buttons (Cont.)

Button name	Signal set	Signals in the signal set
PAL format		
COLOR BAR	Color Bars	100% Colour Bars, 75% Colour Bars, 100% Colour Bars Over Red, 75% Colour Bars Over Red
LINEARITY	Linearity	5 Step, 10 Step, Modulated 5 Step, Modulated 10 Step, Modulated Pedestal, Modulated Ramp, Ramp, Shallow Ramp
FLAT FIELD	Flat Fields	40% Flat Field, 50% Flat Field, 100% Flat Field, Field Square Wave, Black Burst, Black Burst with No Field Ref, Field Square Wave
MULTIBURST	Multiburst	100% Multiburst, 60% Multiburst, Multipulse
SWEEP	Sweep	100% Sweep, 60% Sweep
MONITOR	Monitor	100% Red Field, 75% Red Field, 2 Level Pedestal & Pluge, 4 Level Pedestal & Pluge, Convergence Pattern, Grey Window, White Window, Safe Area, Monitor Setup Matrix
PULSE BAR	Pulse & Bar	2T Pulse & Bar, Sin X/X
OTHER	Other	CCIR 17, CCIR 18, CCIR 330, CCIR 331, UK ITS 1, UK ITS 2, UK 1 Line ITS, ITS Matrix 1

ATG7 Module Main Menu

You can set the text overlay, timing offset, and APL feature of the SIGNAL output using the ATG7 module main menu. This menu also provides the access point to the SELECT OUTPUT submenu where you can set the output parameters for the BLACK 1, BLACK 2, and BARS outputs.

Use the up (▲) or down (▼) arrow button to scroll through the main menu. Figure 2-2 shows the ATG7 module main menu.

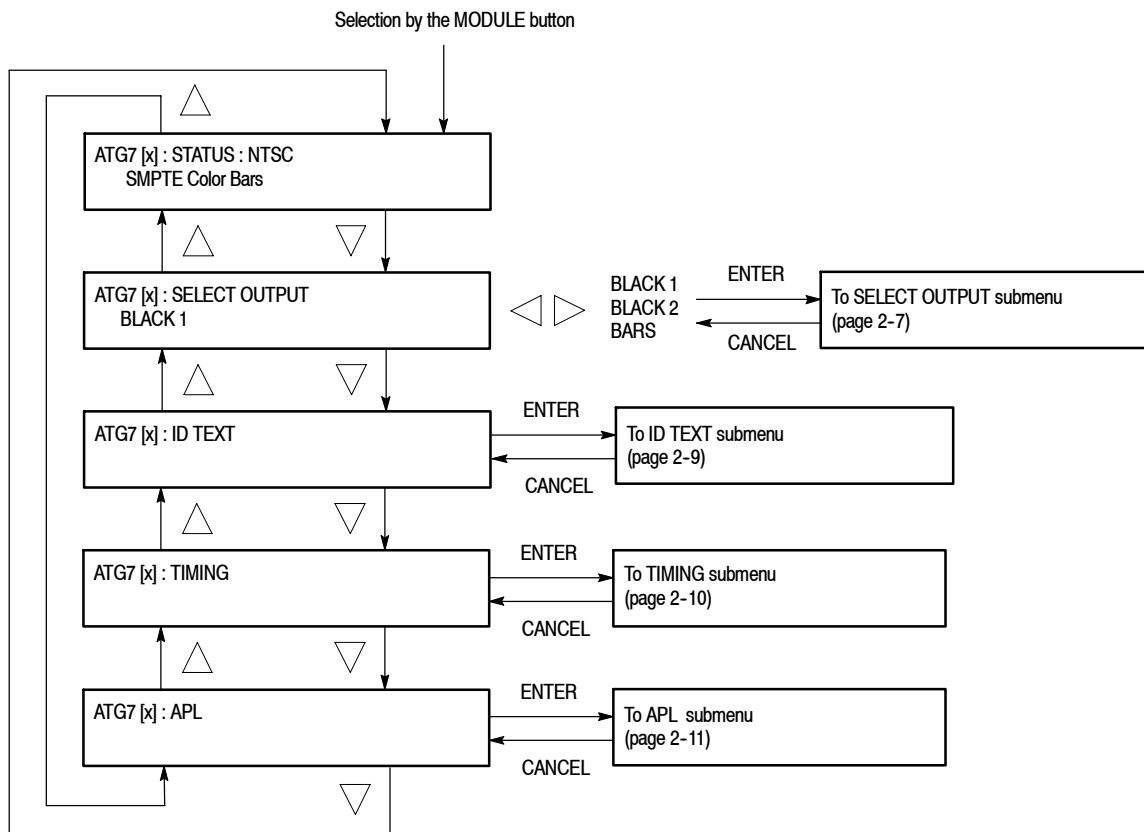

Figure 2-2: ATG7 module main menu

STATUS. Displays the current video standard and signal selection for the SIGNAL output.

SELECT OUTPUT. Select the output whose parameters will be set. Use the left (◀) or right (▶) arrow button to make the selection. The choices are **BLACK 1**, **BLACK 2**, or **BARS**. When you select any of the items and then press the ENTER button, you will access the SELECT OUTPUT submenu. Refer to *SELECT OUTPUT Submenu* on page 2-7 for detailed information.

ID TEXT. Sets a text that is overlaid on the test signal output from the SIGNAL connector. When you select this menu item and then press the ENTER button, you will access the ID TEXT submenu. Refer to *ID TEXT Submenu* on page 2-9 for detailed information.

TIMING. Sets the timing offset of the SIGNAL output relative to the internal reference signal (frame reset signal). When you select this menu item and then press the ENTER button, you will access the TIMING submenu. Refer to *TIMING Submenu* on page 2-10 for detailed information.

APL. Sets the APL and Bounce features available for the signal output from the SIGNAL connector. When you select this menu item and then press the ENTER button, you will access the APL submenu. Refer to *APL Submenu* on page 2-11 for detailed information.

SELECT OUTPUT Submenu

This menu allows you to set the video format, signal, and timing offset for the BLACK 1, BLACK 2, or BARS output. You can also set the ID text overlay for the BARS output using this menu. Figure 2-3 shows the SELECT OUTPUT submenu.

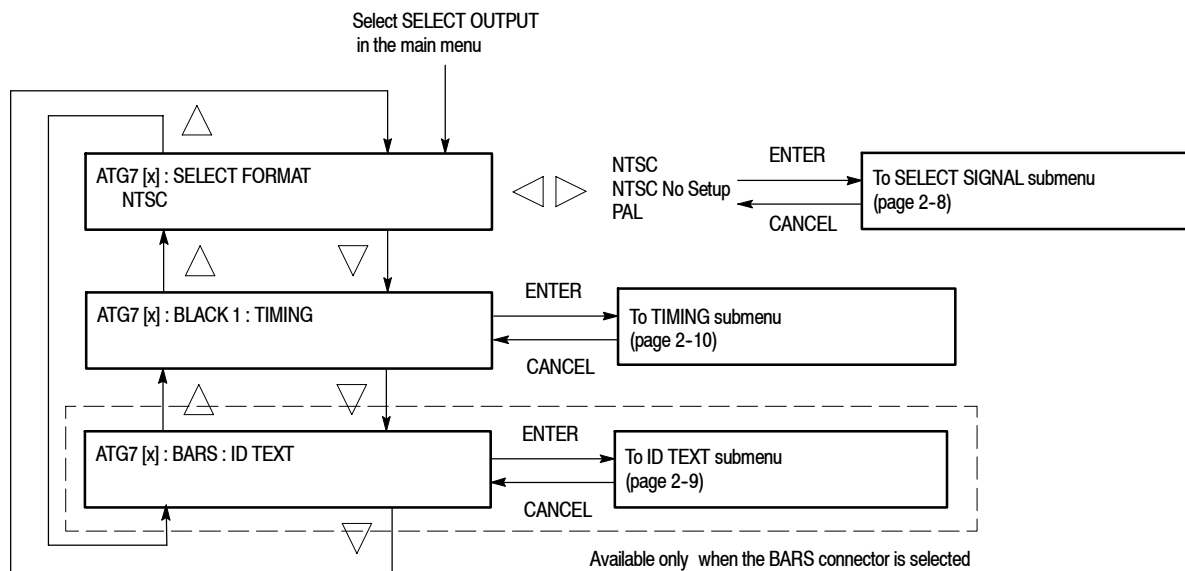

Figure 2-3: SELECT OUTPUT submenu

SELECT FORMAT. Selects the video format for the selected output. Use the left (◀) or right (▶) arrow button to select **NTSC**, **NTSC No Setup**, or **PAL**.

NOTE. When you change the video format, synchronization shock will occur; the video format changes immediately at the output as you change the format selection.

Select the format you want, then press the front-panel ENTER button to access the **SELECT SIGNAL** submenu, where you select the output signal to use. Refer to the *SELECT SIGNAL Submenu* on page 2-8 for detailed information.

TIMING. Sets the timing offset of the selected output relative to the internal reference signal (frame reset signal). Select this menu item and press the ENTER button, to access the **TIMING** submenu. Refer to *TIMING Submenu* on page 2-10 for detailed information.

ID TEXT. Sets a text that is overlaid on the test signal output from the BARS connector. Select this menu item and press the ENTER button, to access the **ID**

TEXT submenu. Refer to *ID TEXT Submenu* on page 2-9 for detailed information.

SELECT SIGNAL Submenu

This menu allows you to select an output signal for the BLACK 1, BLACK 2, or BARS connector. Figure 2-4 shows the SELECT SIGNAL submenu.

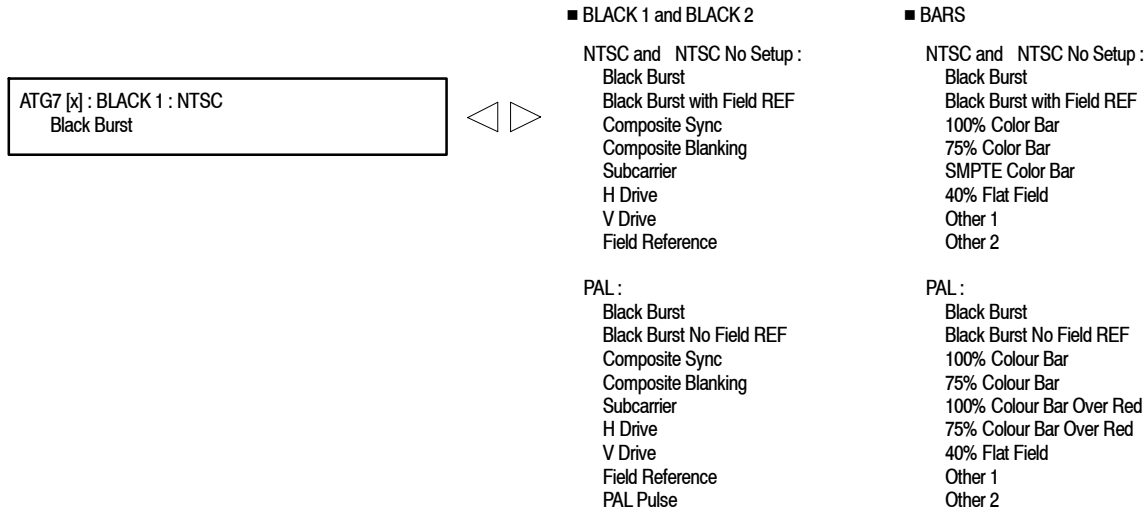

Figure 2-4: SELECT SIGNAL submenu

Use the left (◀) or right (▶) arrow button to scroll through the selections. Press the **ENTER** button to enable the selected signal.

Signals available for selection depend on the selected output connector and video format. Table 2-2 lists the available signals for each output connector and video format.

Table 2-2: Selectable signals in the SELECT SIGNAL submenu

Format	Selectable signals
BLACK1 and BLACK 2 connectors	
NTSC and NTSC No Setup	Black Burst, Black Burst with Field REF, Composite Sync, Composite Blanking, Subcarrier, H Drive, V Drive, Field Reference
PAL	Black Burst, Black Burst No Field REF, Composite Sync, Composite Blanking, Subcarrier, H Drive, V Drive, Field Reference, PAL Pulse

Table 2-2: Selectable signals in the SELECT SIGNAL submenu (Cont.)

Format	Selectable signals
BARS connector	
NTSC and NTSC No Setup	Black Burst, Black Burst with Field REF, 100% Color Bar, 75% Color Bar, SMPTE Color Bar, 40% Flat Field, Other 1 (SNG Color Bars), Other 2 (Monitor Setup Matrix)
PAL	Black Burst, Black Burst No Field REF, 100% Colour Bar, 75% Colour Bar, 100% Colour Bar Over Red, 75% Colour Bar Over Red, 40% Flat Field, Other 1 (4 Level Pedestal & Plug), Other 2 (Monitor Setup Matrix)

ID TEXT Submenu

This menu allows you to edit text that is overlaid on the signal for the SIGNAL and BARS outputs, and to set the display position of the text. Use the up (▲) or down (▼) arrow button to scroll through the menu. Figure 2-5 shows the ID TEXT submenu.

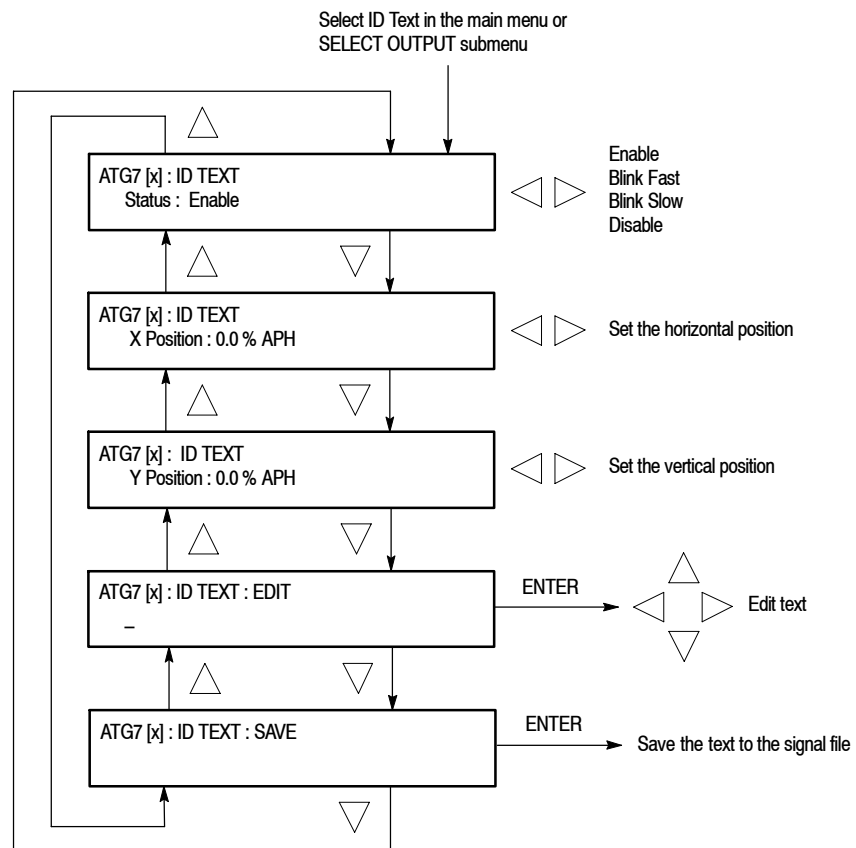

Figure 2-5: ID TEXT submenu

- **Status** : Sets the display status of the text overlay. Use the left (◀) or right (▶) arrow button to select **Enable**, **Blink Fast** (blinks approximately at 0.5 second intervals), **Blink Slow** (blinks approximately at 1.0 second interval), or **Disable**. Press the **ENTER** button to confirm the selection.
- **X Position**: Sets the horizontal position of the text. The position is set as a percentage of active picture width. Use the left (◀) or right (▶) arrow button to change the position. You can set the value from 0.0 % to 100.0 % in 1% steps.
- **Y Position**: Sets the vertical position of the text. The position is set as a percentage of active picture height. Use the left (◀) or right (▶) arrow button to change the position. You can set the value from 0.0 % to 100.0 % in 1% steps.
- **EDIT**: Edits the text you want to display on the output test signal.

To edit the text, first press the **ENTER** button to enable the text edit mode. Use the left (◀) or right (▶) arrow button to move the underscore character (_) to the character you want to change, and then use the up (▲) or down (▼) arrow button to select the desired character. When you have entered all the desired characters, press the **ENTER** button to end the text editing process. You can use up to 18 characters for the text. Use the blank character to erase an unneeded character(s).
- **SAVE**: Saves the text and its position to the signal file currently being output. Press the **ENTER** button to save them to the signal file.

TIMING Submenu

This menu allows you to adjust the timing offset of the selected output relative to the internal reference signal (frame reset signal). Use the up (▲) or down (▼) arrow button to scroll through the menu. Figure 2-6 shows the TIMING submenu.

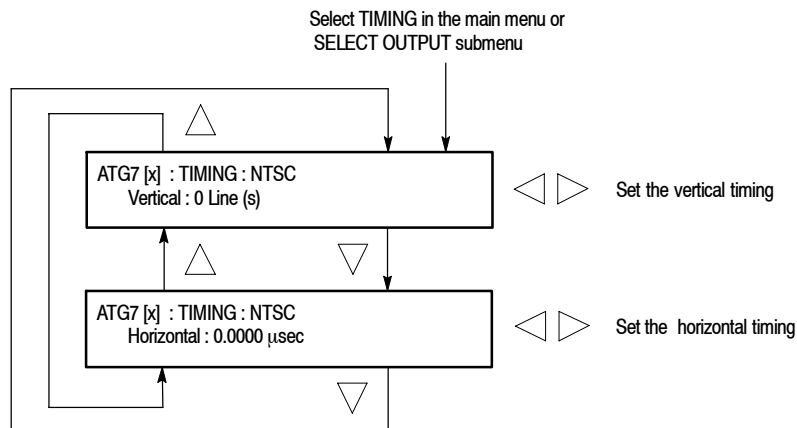

Figure 2-6: TIMING submenu

- **Vertical** : Sets the vertical timing offset. Use the left (◀) or right (▶) arrow button to change the timing offset. You can set the value from -1/2 color frame to +1/2 color frame in 1 line steps.
- **Horizontal** : Sets the horizontal timing offset. Use the left (◀) or right (▶) arrow button to adjust the timing offset. You can set the value from -1 line to +1 line in one clock steps (18.5 ns).

NOTE. You can reset the timing offset to zero by pressing the left (◀) and right (▶) arrow buttons simultaneously.

The ATG7 horizontal timing can only be adjusted in clock cycle increments. You can match the AGL7 timing to the ATG7 by adjusting the AGL7 fine timing controls.

APL Submenu

This menu allows you to set the APL and Bounce features for the test signal output from the SIGNAL connector. Use the up (▲) or down (▼) arrow button to scroll through the menu. Figure 2-7 shows the APL submenu.

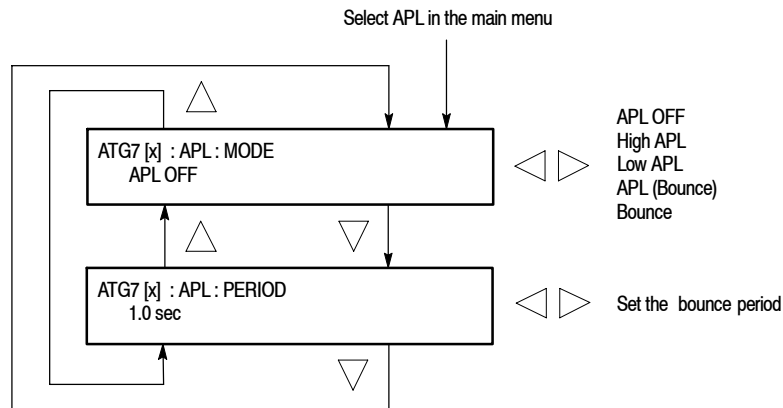

Figure 2-7: APL submenu

- **MODE** : Sets the output mode of the APL signal. Use the left (◀) or right (▶) arrow button to select the mode. The choices are:
 - **APL OFF** : Outputs the selected signal without making any changes.
 - **High APL** : Divides the video lines of the selected signal into 5 lines (for NTSC) or 4 lines (for PAL) and changes the lines except the last line to the 100 % flat field signal, and then outputs them.
 - **Low APL** : Divides the video lines of the selected signal into 5 lines (for NTSC) or 4 lines (for PAL) and changes the lines except the last line to the 0 % flat field signal, and then outputs them.
 - **APL (Bounce)** : Outputs the High APL signal and Low APL signal alternately for the period set in the PERIOD menu item.
 - **Bounce** : Outputs the 100 % flat field signal and 0% flat field signal alternately (regardless of the selected signal) for the period set in the PERIOD menu item.

Press the **ENTER** button to confirm the selection.

- **PERIOD** : Sets the time interval between two signals when they are output in APL (Bounce) or Bounce mode. Use the left (◀) or right (▶) arrow button to change the interval. You can set the value from 0.5 seconds to 2.0 seconds in 0.5 second steps.

Rear-Panel Connectors

The ATG7 Generator module is equipped with four BNC connectors: BLACK 1, BLACK 2, SIGNAL, and BARS. Figure 2-8 shows the ATG7 Generator module rear-panel connectors.

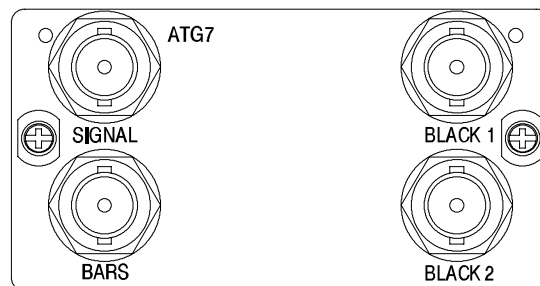

Figure 2-8: ATG7 module rear-panel connectors

- **BLACK 1** : Outputs the black burst signals, timing pulse signals, and subcarrier signal.
- **BLACK 2** : Outputs the black burst signals, timing pulse signals, and subcarrier signal.
- **SIGNAL** : Outputs the signals assigned to the front-panel test signal buttons. Refer to Table 2-1 on page 2-3 about the signal sets available for the connector.
- **BARS** : Outputs the black burst signals and color bars signals.

Factory Default Settings

Table 2-3 shows the factory default settings for the ATG7 Generator module. These settings are recalled when you select **Factory Default** from the **PRESET : RECALL** menu item in the mainframe main menu.

Table 2-3: Factory default settings

Menu item name	Settings
STATUS (Shows the signal format and signal name output from the SIGNAL connector)	NTSC SMPTE Color Bars
OUTPUT : BLACK 1 and BLACK 2	
FORMAT	NTSC
SIGNAL	Black Burst

Table 2-3: Factory default settings (Cont.)

Menu item name	Settings
OUTPUT : BARS	
FORMAT	NTSC
SIGNAL	SMPTE Color Bar
ID TEXT	
Status	Disable
TIMING	
Vertical	0 Line(s)
Horizontal	0.0000 μ sec
APL	
Mode	APL OFF
Period	1.0 sec



Reference

Syntax

This section contains information on the Standard Commands for Programmable Instruments (SCPI) and the programming structure you can use to program your ATG7 Generator module.

Programming Model

Specific conditions must exist before programming commands will affect the test signal generated by a module.

Selecting the Module

Select the module using the :INSTRument:SElect command before executing any commands. Many of the commands used by the ATG7 module are shared by several modules and will be accepted without a reported error.

Command Arguments

Many commands will accept either string or numeric arguments. For example: a boolean argument can either be “1” or “ON”.

Signal parameter commands that have a :STEP node can accept either a numeric value or they can accept a string argument that refers to the :STEP increment.

Signal parameter commands with a :STEP node will accept the following strings in addition to a numeric value:

UP. Use this argument to increase the parameter value one increment as defined by the :STEP value.

DOWN. Use this argument to decrease the parameter value one increment as defined by the :STEP value.

MINimum. Use this argument to set the parameter value to the minimum acceptable value.

MAXimum. Use this argument to set the parameter value to the maximum acceptable value.

DEFault. Use this argument to set the parameter value to the default value.

Query Arguments

If you send a query with no argument, the response is the current value. You can also use **MINimum**, **MAXimum**, and **DEFault** as arguments for queries whose command form can use these arguments (refer to the command syntax for the specific command). Instead of returning the current value, queries using these arguments return the following information:

MINimum. Return the minimum acceptable value.

MAXimum. Return the maximum acceptable value.

DEFault. Return the default value.

Argument Example

The following example demonstrates the effect of each of the arguments when used with a step value.

1. `:INSTRument:SElect "HDVG7:#"` selects the digital video generator module located in the slot number indicated by the “#” symbol.
2. `:OUTPut:CIRClE:STATe ON` displays a circle on the video display.

NOTE. `:OUTPut:CIRClE:DIAMeter` uses an argument that is the percent of picture height.

3. `:OUTPut:CIRClE:DIAMeter DEFaul t` sets the circle diameter to 90 percent of the screen height.
4. `:OUTPut:CIRClE:DIAMeter:STEP 10` sets the step increment to 10 percent.
5. `:OUTPut:CIRClE:DIAMeter DOWN` changes the circle diameter to 80 percent of the screen height.
6. `:OUTPut:CIRClE:DIAMeter 50` changes the circle diameter to 50 percent of the screen height.
7. `:OUTPut:CIRClE:DIAMeter MAXimum` changes the circle diameter to 100 percent of the screen height.
8. `:OUTPut:CIRClE:DIAMeter MINimum` changes the circle diameter to 0 percent of the screen height.
9. `:OUTPut:CIRClE:DIAMeter UP` changes the circle diameter to 10 percent of the screen height.
10. `:OUTPut:CIRClE:DIAMeter? MAXimum` queries the maximum circle diameter (not the current diameter). The query returns the value of 100 percent, which is the maximum circle diameter allowable.

SCPI Commands and Queries

SCPI is a standard created by a consortium that provides guidelines for remote programming of instruments. These guidelines provide a consistent programming environment for instrument control and data transfer. This environment uses defined programming messages, instrument responses, and data format across all SCPI instruments, regardless of manufacturer. The ATG7 Generator module uses a command language based on the SCPI standard.

The SCPI language is based on a hierarchical or tree structure (see Figure 3-1) that represents a subsystem. The top level of the tree is the root node; it is followed by one or more lower-level nodes.

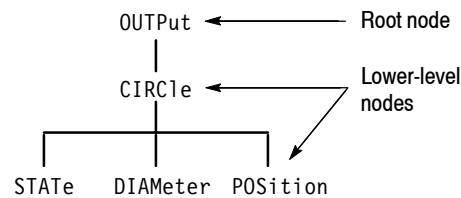

Figure 3-1: Example of SCPI subsystem hierarchy

You can create commands and queries from these subsystem hierarchy trees. Commands specify actions for the instrument to perform. Queries return measurement data and information about parameter settings.

For more information on SCPI commands and programming structure, refer to the *TG700 Signal Generator Platform User Manual*.

Remote Commands

This section describes the command sets used for the ATG7 Generator module remote operation. The commands for the module are divided into the following three groups:

- MASS MEMORY commands (Refer to the *TG700 TV Signal Generator Platform User Manual*)
- OUTPUT commands
- SENSE commands

MASS MEMORY Commands

Two MASS MEMORY commands are listed here for your reference. You can use these to load and query the output test signal. Detailed information for using these commands are located in the *TG700 TV Signal Generator Platform User Manual*.

```
:MMEMory:LOAD:SIGNa1 <module_name>,<signal_name>  
:MMEMory:LOAD:SIGNa1 <slot_number>,<signal_name>
```

Loads a signal into the specified module.

```
:MMEMory:SIGNa1:ACTive? <slot_number>|<module_name>
```

Returns the current output signal of the specified module.

OUTPUT Commands

Use these commands to control the output parameters of the module. These include ID text overlay and APL features.

Command Tree

```

:OUTPut<n>
  :STANdard          NTSC|NTSC_NSU|PAL
  :SIGNal           BB|BB_FREF|BB_NO_FREF|SYNC|BLANKING|
                   SUBCARRIER|H_DRIVE|V_DRIVE|FREF|
                   PAL_PULSE (n=1,2)

                   BB|BB_NO_FREF|CB100_PER|CB75_PER|
                   CB_SMPTE|FF40PER|CB100_OR|CB75_OR|
                   OTHER_ONE|OTHER_TWO (n=4)

:OVERlay
  :BLINK
  :STATe            ON|OFF
  :PERiod           <numeric_value>

:TEXT
  :STATe            ON|OFF
  :DATA             <string>
  :POSition
    :HORizontal     <numeric_value>
    :VERTical       <numeric_value>
  :SAVe

:APL
  :MODE             APL_OFF|APL_HIGH|APL_LOW|APL_BOUNCE
  :PERiod           <numeric_value>

```

Command Description

:OUTPut<n>:STANdard NTSC|NTSC_NSU|PAL

Sets the video standard for the BLACK 1, BLACK 2, or BARS output. The choices are NTSC, NTSC_NSU (NTSC no setup), or PAL. The <n> in the command represents the output connector type and you can specify 1, 2, or 4. “1” represents the BLACK 1 connector, “2” represents the BLACK 2 connector, and “4” represents the BARS connector.

:OUTPut<n>:STANdard?

Returns the video standard for the BLACK 1, BLACK 2, or BARS output. The <n> in the command represents the output connector and you can specify 1, 2, or 4. “1” represents the BLACK 1 connector, “2” represents the BLACK 2 connector, and “4” represents the BARS connector.

```
:OUTPut<n>:SIGNa1 BB|BB_FREF|BB_NO_FREF|SYNC|BLANKING|
SUBCARRIER|H_DRIVE|V_DRIVE|FREF|
PAL_PULSE (n=1,2)
BB|BB_NO_FREF|CB100_PER|CB75_PER|CB_SMPTE|
FF40PER|CB100_OR|CB75_OR|OTHER_ONE|
OTHER_TWO (n=4)
```

Sets the signal available from the BLACK 1, BLACK 2, or BARS output. The <n> in the command represents the output connector and you can specify 1, 2, or 4. “1” represents the BLACK 1 connector, “2” represents the BLACK 2 connector, and “4” represents the BARS connector.

If “1” or “2” is specified for the connector type, the choices are BB (black burst), BB_FREF (black burst with field reference), BB_NO_FREF (black burst no field reference), SYNC (composite sync), BLANKING (composite blanking), SUBCARRIER (subcarrier), H_DRIVE (H drive), V_DRIVE (V drive), FREF (Color Frame ID), or PAL PULSE (PAL pulse).

If “4” is specified for the connector type, the choices are BB (black burst), BB_FREF (black burst with field reference), BB_NO_FREF (black burst no field reference), CB100PER (100 % color (or colour) bars), CB75PER (75 % color (or colour) bars), CB_100_OR (100 % colour bars over red), CB_75_OR (75 % colour bars over red), CB_SMPTE (SMPTE color bars), FF40PER (40 % flat field), OTHER_ONE (Other 1), or OTHER_TWO (Other 2).

:OUTPut<n>:SIGNa1?

Returns the current output signal for the BLACK 1, BLACK 2, or BARS output. The <n> in the command represents the output connector and you can specify 1, 2, or 4. “1” represents the BLACK 1 connector, “2” represents the BLACK 2 connector, and “4” represents the BARS connector.

:OUTPut<n>:OVERlay:BLINK:STATe ON|OFF

Turns the text blinking mode on or off. You can also use 1 or 0 instead of ON or OFF. The <n> in the command represents the output connector and you can specify 3 or 4. “3” represents the SIGNAL connector and “4” represents the BARS connector.

`:OUTPut<n>:OVERlay:BLINK:STATe?`

Returns the current state of the text blinking mode. The <n> in the command represents the output connector and you can specify 3 or 4. “3” represents the SIGNAL connector and “4” represents the BARS connector.

`:OUTPut<n>:OVERlay:BLINK:PERiod <numeric_value>`

Sets the blinking interval of the text blinking mode. You can set the value as 0.5 seconds or 1.0 seconds. The <n> in the command represents the output connector and you can specify 3 or 4. “3” represents the SIGNAL connector and “4” represents the BARS connector.

`:OUTPut<n>:OVERlay:BLINK:PERiod?`

Returns the blinking interval of the text blinking mode. The <n> in the command represents the output connector and you can specify 3 or 4. “3” represents the SIGNAL connector and “4” represents the BARS connector.

`:OUTPut<n>:TEXT:STATe ON|OFF`

Turns the text overlay on the video signal on or off. You can also use 1 or 0 instead of ON or OFF. The <n> in the command represents the output connector and you can specify 3 or 4. “3” represents the SIGNAL connector and “4” represents the BARS connector.

`:OUTPut<n>:TEXT:STATe?`

Returns the current text overlay state. The <n> in the command represents the output connector and you can specify 3 or 4. “3” represents the SIGNAL connector and “4” represents the BARS connector.

`:OUTPut<n>:TEXT:DATA <string>`

Sets the current string for the text overlay mode. The <n> in the command represents the output connector and you can specify 3 or 4. “3” represents the SIGNAL connector and “4” represents the BARS connector. The text string may contain up to 18 characters.

`:OUTPut<n>:TEXT:DATA?`

Returns the current string for the text overlay mode. The <n> in the command represents the output connector and you can specify 3 or 4. “3” represents the SIGNAL connector and “4” represents the BARS connector.

`:OUTPut<n>:TEXT:POSition:HORizontal <numeric_value>`

Sets the text horizontal position in the video signal. The unit is percent of active picture width. You can set the position from 0 % to 100 % in 1 % steps. You can also use MIN, MAX, or DEF instead of the numeric value. The <n> in the command represents the output connector and you can specify 3 or 4. “3” represents the SIGNAL connector and “4” represents the BARS connector.

`:OUTPut<n>:TEXT:POSition:HORizontal?`

Returns the current text horizontal position in the video signal. The <n> in the command represents the output connector and you can specify 3 or 4. “3” represents the SIGNAL connector and “4” represents the BARS connector.

`:OUTPut<n>:TEXT:POSition:VERTical <numeric_value>`

Sets the text vertical position in the video signal. The unit is percent of active picture height. You can set the position from 0 % to 100 % in 1 % steps. You can also use MIN, MAX, or DEF instead of the numeric value. The <n> in the command represents the output connector and you can specify 3 or 4. “3” represents the SIGNAL connector and “4” represents the BARS connector.

`:OUTPut<n>:TEXT:POSition:VERTical?`

Returns the current text vertical position in the video signal. The <n> in the command represents the output connector and you can specify 3 or 4. “3” represents the SIGNAL connector and “4” represents the BARS connector.

`:OUTPut<n>:TEXT:SAVE`

Saves the current text and its display position to the signal file. There are no arguments. The <n> in the command represents the output connector and you can specify 3 or 4. “3” represents the SIGNAL connector and “4” represents the BARS connector.

`:OUTPut<n>:APL:MODE APL_OFF|APL_HIGH|APL_LOW|APL_BOUNCE|BOUNCE`

Sets the output mode of the APL signal. Refer to *Operating Basics* for detailed information about the each mode. You can only specify “3” (SIGNAL connector) for the <n>.

`:OUTPut<n>:APL:MODE?`

Returns the current output mode of the APL signal. You can specify only “3” (SIGNAL connector) for the <n>.

:OUTPut<n>:APL:PERiod <numeric_value>

Sets the time interval between two signals when they are output in the bounce modes. You can set the value from 0.5 seconds to 2.0 seconds in 0.5 seconds steps. You can specify only “3” (SIGNAL connector) for the <n>.

:OUTPut<n>:APL:PERiod?

Returns the time interval between two signals when they are output in the bounce modes. You can specify only “3” (SIGNAL connector) for the <n>.

SENSE Commands

Use these commands to adjust the timing offset of each output relative to the internal reference signal (frame reset signal).

Refer to *Operating Basics* about the timing offset range.

Command Tree

```
:SENSe<n>
  :CORRection
    :MDElay
      :HORizontal <numeric_value>
        :STEP <numeric_value>
      :VERTical <numeric_value>
        :STEP <numeric_value>
```

Command Description

:SENSe<n>:CORRection:MDElay:HORizontal <numeric_value>

Sets the horizontal timing offset for the specified output. The timing resolution is clock-cycles. The unit is microseconds. You can use UP, DOWN, or DEF instead of the numeric values. If the argument exceeds the horizontal time value, then the vertical offset is adjusted to accommodate the requested offset. The <n> in the command represents the output connector and you can specify from 1 through 4. “1” represents the BLACK 1 connector, “2” represents the BLACK 2 connector, “3” represents the SIGNAL connector, and “4” represents the BARS connector.

`:SENSe<n>:CORRection:MDELay:HORizontal?`

Returns the horizontal timing offset of the specified output. The <n> in the command represents the output connector and you can specify from 1 through 4. “1” represents the BLACK 1 connector, “2” represents the BLACK 2 connector, “3” represents the SIGNAL connector, and “4” represents the BARS connector.

`:SENSe<n>:CORRection:MDELay:HORizontal:STEP <numeric_value>`

Sets the step increment used by the UP or DOWN commands. The unit is microseconds. You can use UP, DOWN, or DEF instead of the numeric values. The <n> in the command represents the output connector and you can specify from 1 through 4. “1” represents the BLACK 1 connector, “2” represents the BLACK 2 connector, “3” represents the SIGNAL connector, and “4” represents the BARS connector.

`:SENSe<n>:CORRection:MDELay:HORizontal:STEP?`

Returns the step increment used by the UP or DOWN commands. The <n> in the command represents the output connector and you can specify from 1 through 4. “1” represents the BLACK 1 connector, “2” represents the BLACK 2 connector, “3” represents the SIGNAL connector, and “4” represents the BARS connector.

`:SENSe<n>:CORRection:MDELay:VERTical <numeric_value>`

Sets the vertical timing offset of the specified output. The argument can be a floating point value that is translated into integer lines with a horizontal offset. You can use UP, DOWN, or DEF instead of a numeric value. The <n> in the command represents the output connector and you can specify from 1 through 4. “1” represents the BLACK 1 connector, “2” represents the BLACK 2 connector, “3” represents the SIGNAL connector, and “4” represents the BARS connector.

`:SENSe<n>:CORRection:MDELay:VERTical?`

Returns the vertical timing offset of the specified output. The <n> in the command represents the output connector and you can specify from 1 through 4. “1” represents the BLACK 1 connector, “2” represents the BLACK 2 connector, “3” represents the SIGNAL connector, and “4” represents the BARS connector.

`:SENSe<n>:CORRection:MDELay:VERTical:STEP <numeric_value>`

Sets the step increment used by the UP or DOWN commands. You can use MIN, MAX, or DEF instead of the numeric values. The <n> in the command represents the output connector and you can specify from 1 through 4. “1” represents the BLACK 1 connector, “2” represents the BLACK 2 connector, “3” represents the SIGNAL connector, and “4” represents the BARS connector.

`:SENSe<n>:CORRection:MDELay:VERTical:STEP?`

Returns the step increment used by the UP or DOWN commands. The <n> in the command represents the output connector and you can specify from 1 through 4. “1” represents the BLACK 1 connector, “2” represents the BLACK 2 connector, “3” represents the SIGNAL connector, and “4” represents the BARS connector.



Appendices

Appendix A: Specifications

Tables A-1 through A-5 list the electrical characteristics and the environmental characteristics of the ATG7 Generator module.

Electrical Characteristics

Table A- 1: Black burst and timing pulse outputs

Characteristic	Performance requirements	Reference information
Connector	BNC	
Number of outputs	2	BLACK 1 and BLACK 2
Output impedance, typical	75 Ω	
Black burst output signals		
NTSC and NTSC No Setup		Black Burst Black Burst with Field REF
PAL		Black Burst Black Burst with No Field REF
Timing pulse output		
Amplitude accuracy	1.0 \pm 0.1 V	
Rise time		
NTSC and NTSC No Setup	140 \pm 20 ns	
PAL	250 \pm 20 ns	
Output signals		
NTSC and NTSC No Setup		Composite Sync Composite Blanking Subcarrier H Drive V Drive Field Reference
PAL		Composite Sync Composite Blanking Subcarrier H Drive V Drive Field Reference PAL Pulse

Table A-2: Color bars signal output

Characteristic	Performance requirements	Reference information
Connector	BNC	
Number of outputs	1	BARS
Output impedance, typical	75 Ω	
Output signals NTSC and NTSC No Setup		SMPTE Color Bar 100% Color Bar 75% Color Bar 40% Flat Field Black Burst Black Burst with Field REF Other 1 Other 2
PAL		100% Colour Bar 75% Colour Bar 100% Colour Bar Over Red 75% Colour Bar Over Red 40% Flat Field Black Burst Black Burst No Field REF Other 1 Other 2
ID text	Maximum 18 characters	
Luminance amplitude accuracy	$\pm 1\%$	Measured at 700 mV.
Chrominance to luminance gain	$\pm 2\%$	Chrominance is measured at red portion of the 75% Colour Bar Over Red signal.

Table A-3: Test signal output

Characteristic	Performance requirements	Reference information
Connector	BNC	
Number of outputs	1	SIGNAL
Output impedance, typical	75 Ω	
Output signals		Refer to Table 2-1 on page 2-3 for detailed information about the output signals.
ID text	Maximum 18 characters	
Luminance amplitude accuracy	$\pm 1\%$	Measured at 700 mV.
Chrominance to luminance gain	$\pm 1\%$	
Frequency response	$\pm 1\%$	To 5 MHz
Chrominance to luminance delay	≤ 10 ns	Measured at 500 kHz and 4.43 MHz.
Linearity	$< 1\%$	$< 0.5\%$ (typical); measured at 5 step signal.
Differential gain error	$< 0.5\%$	Measured at modulated 5 step signal.
Differential phase error	$< 0.5^\circ$	Measured at modulated 5 step signal.
Field tilt	$< 0.5\%$	
Line tilt	$< 0.5\%$	

Table A-4: Common outputs characteristics

Characteristic	Performance requirements	Reference information
Return loss	≥ 36 dB	To 6 MHz
Burst amplitude accuracy	$\pm 2\%$	
Sync amplitude accuracy	$\pm 2\%$	
Blanking level	0 mV \pm 50 mV	
SCH phase accuracy	$0^\circ \pm 5^\circ$	
Timing offset		
Range	Full color frame	
Resolution	54 MHz clock resolution	≈ 18.5 ns

Environmental Characteristics

Table A-5: Environmental characteristics

Characteristic	Description
Temperature	
Operating	0 °C to +50 °C
Nonoperating	-20 °C to +60 °C
Relative Humidity	
Operating	20% to 80% (No condensation) ; Maximum wet-bulb temperature 29.4 °C
Nonoperating	5% to 90% (No condensation) ; Maximum wet-bulb temperature 40.0 °C
Altitude	
Operating	To 4.5 km (15,000 feet) Maximum operating temperature decreases 1 °C each 300 m above 1.5 km.
Nonoperating	To 15 km (50,000 feet)
Vibration	
Operating	3.04 m/s ² (0.31 G _{rms}), 5 Hz to 500 Hz, 10 min, three axes
Nonoperating	23.3 m/s ² (2.38 G _{rms}), 5 Hz to 500 Hz, 10 min, three axes
Shock	
Nonoperating	294 m/s ² (30 G), half-sine, 11 ms duration



Index

Index

A

Accessories
 optional, 1-2
 standard, 1-2
APL, 2-11
APL submenu, 2-11
ATG7 features, 1-1
ATG7 module main menu, 2-5
 APL, 2-6
 ID TEXT, 2-6, 2-7
 SELECT OUTPUT, 2-6
 STATUS, 2-6
 TIMING, 2-6

B

BARS connector, 2-13
BLACK 1 connector, 2-13
BLACK 2 connector, 2-13
Bounce, 2-12

C

Commands
 Rules for forming, 3-1
 Syntax, 3-1

E

Electrical specifications, A-1
Environmental specifications, A-4

F

Factory default settings, 2-13
Functional check, 1-3
Functional command groups, 3-5

H

Hierarchy (SCPI), 3-3

I

ID TEXT submenu, 2-9

Installation, 1-2

M

Manuals, Related, iii
MASS MEMORY commands, 3-5

O

Operating procedure, 2-1
Option, 1-2
Optional accessories, 1-2
OUTPUT commands, 3-6

P

Product description, 1-1

R

Rear-panel connectors, 2-13
Related Manuals, iii
Rules, Command forming, 3-1

S

SCPI, Subsystem hierarchy tree, 3-3
SCPI commands and queries syntax, 3-3-3-4
SELECT OUTPUT submenu, 2-7
SELECT SIGNAL submenu, 2-8
SENSE commands, 3-10
SIGNAL connector, 2-13
Signal set assigned to the test signal buttons, 2-3
Specifications
 Electrical, A-1
 Environmental, A-4
Standard accessories, 1-2
Syntax, Command, 3-1

T

Text overlay, 2-9
TIMING submenu, 2-10

User Manual



AVG7 Analog Video Generator

Copyright © Tektronix. All rights reserved. Licensed software products are owned by Tektronix or its suppliers and are protected by United States copyright laws and international treaty provisions.

Tektronix products are covered by U.S. and foreign patents, issued and pending. Information in this publication supercedes that in all previously published material. Specifications and price change privileges reserved.

TEKTRONIX and TEK are registered trademarks of Tektronix, Inc.

Contacting Tektronix

Tektronix, Inc.
14200 SW Karl Braun Drive
P.O. Box 500
Beaverton, OR 97077
USA

For product information, sales, service, and technical support:

- In North America, call 1-800-833-9200.
- Worldwide, visit www.tektronix.com to find contacts in your area.

Table of Contents

Preface	iii
About This Manual	iii
Related Manuals	iii
Getting Started	
Product Description	1-1
Accessories	1-2
Option	1-2
Installation	1-2
Functional Check	1-2
Operating Basics	
Operating Procedure	2-1
Selecting an Output Signal	2-2
AVG7 Module Main Menu	2-8
Rear-Panel Connectors	2-20
Factory Default Settings	2-21
Reference	
Syntax	3-1
Programming Model	3-1
SCPI Commands and Queries	3-3
Remote Commands	3-5
MASS MEMORY Commands	3-5
OUTPUT Commands	3-6
SENSE Commands	3-12
Appendices	
Appendix A: Specifications	A-1
Electrical Characteristics	A-1
Environmental Characteristics	A-3
Index	

List of Figures

Figure 2-1: Front-panel test signal buttons	2-3
Figure 2-2: AVG7 module main menu	2-8
Figure 2-3: MOVING PICTURE submenu	2-10
Figure 2-4: OVERLAY submenu	2-11
Figure 2-5: LOGO submenu	2-12
Figure 2-6: ID TEXT submenu	2-13
Figure 2-7: CIRCLE submenu	2-14
Figure 2-8: TIMING submenu	2-16
Figure 2-9: VIDEO submenu	2-17
Figure 2-10: APL submenu	2-19
Figure 2-11: AVG7 module rear-panel connectors	2-20
Figure 3-1: Example of SCPI subsystem hierarchy	3-3

List of Tables

Table 1-1: Standard and optional accessories	1-2
Table 2-1: Signal set assigned to the test signal buttons	2-3
Table 2-2: Factory default settings	2-20
Table A-1: Output channels	A-1
Table A-2: Common output characteristics	A-1
Table A-3: Environmental characteristics	A-3

Preface

This manual documents the capabilities, operation, and specifications of the AVG7 Analog Video Generator module.

About This Manual

This manual is composed of the following sections:

- *Getting Started* contains product description and functional check procedure.
- *Operating Basics* explains how to operate the AVG7 module using the menus and front-panel buttons.
- *Reference* provides the syntax used in command descriptions and describes all programming commands.
- *Appendices* provides the specifications.

Related Manuals

The following documents are also available.

- The *TG700 TV Signal Generator Platform Service Manual* (Tektronix part number 070-A800-XX) describes how to maintain and service the mainframe and generator modules. This manual is an optional accessory.
- The *TG700 TV Signal Generator Platform Module Installation Instructions* (Tektronix part number 070-A824-XX) describes how to install and remove the modules, and how to upgrade the firmware of the mainframe.



Getting Started

Getting Started

This section contains the following information:

- Product description
- Accessories
- Option
- Installation
- Functional check

Product Description

The AVG7 Analog Video Generator module is designed to be installed in the TG700 TV Signal Generator Platform. The TG700 platform must be running version 3.1 or later firmware.

The module is an analog video signal generator which provides analog composite and component video signals in various formats. The module contains the following features:

- Supports the following system formats:
NTSC, NTSC no setup, PAL, 525 GBR, 525 YPbPr, 525 Beta, 625 GBR, 625YPbPr
- Six analog composite or component video outputs
- Outputs a frame picture created by the Frame Picture Generator application (TG700 Option FP required)
- Overlay of circle, text, or logo on the video signal
- Generates a moving picture by scrolling the active picture area of the output test signal
- Full remote control using Ethernet interface

Accessories

Table 1-1 lists the standard and optional accessories provided with the AVG7 Generator module.

Table 1-1: Standard and optional accessories

Accessory	Std.	Opt.	Tektronix part number
TG700 TV Signal Generator Platform Module Installation Instructions	●		070-A824-XX
TG700 Signal Generator Platform Software Library CD-ROM	●		062-A249-XX
TG700 TV Signal Generator Platform Service Manual		●	070-A800-XX

Option

This subsection describes the option available for the AVG7 Generator module. The following option is available:

Option D1 (Test data report)

Option D1 (Test Data Report)

A calibration test data report will be provided with the AVG7 Generator module when this option is specified.

Installation

Refer to the *TG700 TV Signal Generator Platform Module Installation Instructions* for instructions on how to install the AVG7 Generator module.

Functional Check

The following procedure determines whether the module is operating correctly.

Required equipment

The following equipment is required for the functional check:

- Waveform monitor
- 75 Ω BNC cable

Procedure

1. Install the module into the TG700 Platform mainframe using the installation procedures described in the *TG700 TV Signal Generator Platform User Manual*.
2. Power on the TG700 TV Signal Generator Platform by connecting it to the power source. The initialization of all the installed modules is executed.
3. Check that no error messages appear on the LCD display.
4. Warm up the instrument for 20 minutes.
5. Press the front-panel **MODULE** button until the *AVG7* main menu shown below appears.

```
AVG7 [x]: STATUS: NTSC
          SMPTE Color Bars
```

6. Press the **FORMAT** button and use the left (◀) or right (▶) arrow button to select a format, then press the **ENTER** button.
7. Press one of the front-panel test signal buttons (for example **COLOR BAR**) to output a signal.
8. Press the **CANCEL** button to display the main menu.
9. Press the up (▲) or down (▼) arrow button to select **VIDEO** from the main menu and then press the **ENTER** button. The **VIDEO** submenu shown below appears.

```
AVG7 [x]: VIDEO: CONFIGURATION
          CH1/2/3: Composites
```

10. Press the left (◀) or right (▶) arrow button to select **CH1/2/3: Composites** and then press the **ENTER** button.
11. Connect the upper (or lower) **CH 1** connector to the waveform monitor using the 75 Ω BNC cable.
12. Set the waveform monitor to view the signal.
13. Check that the signal appears as expected. For example, if you selected a color bar signal in step 7, check that the color bar signal appears.
14. Disconnect the BNC cable from the **CH 1** connector, and then connect the BNC cable to the **CH 2** connector.

- 15.** Check that the signal appears as expected.
- 16.** Disconnect the BNC cable from the **CH 2** connector, and then connect the BNC cable to the **CH 3** connector.
- 17.** Check that the signal appears as expected.
- 18.** Disconnect the BNC cable from the **CH 3** connector, and then connect the BNC cable to the **CH 1** connector.
- 19.** Press the test signal button again to output the another test signal in the same signal set.
- 20.** Check that the signal on the waveform monitor changes. You need not perform this check for the CH 2 and CH 3 connectors.
- 21.** Repeat steps 11 through 20 for the lower (or upper) output channels.



Operating Basics

Operating Basics

This section explains the operation of the AVG7 Generator module using the front-panel buttons and menus. It also contains descriptions of the rear-panel connectors.

Refer to the *TG700 TV Signal Generator Platform User Manual* for a detailed explanation of the front-panel buttons and the LCD display.

Operating Procedure

After the module is installed in the mainframe, and the mainframe is installed in the rack or other location where it will be used, access each function of the module with the following procedure:

1. Connect the power connector on the rear panel to the AC electric power source using the power cord.

Electric power is supplied to the mainframe.

2. Wait until the power up initialization process is complete, and check that no error messages appear on the display.
3. Following the initialization process the mainframe main menu appears, as shown below.



TG700 : PRESET

4. Press the front-panel **MODULE** button until the AVG7 module main menu appears, as shown below.



AVG7 [x] : STATUS : NTSC
SMPTE Color Bars

5. Select the signal format and the signal you want to output. Refer to *Selecting an Output Signal* on page 2-2 for more information.
6. Press the front-panel arrow buttons to select the desired main menu item or submenu item.

Refer to *AVG7 Module Main Menu* beginning on page 2-8 for detailed information about the main menu items and the submenu items.

Selecting an Output Signal

When you output a signal from the AVG7 Generator module, you need to select a signal format and output signal. This subsection provides instructions on how to output a signal.

Selecting a Format

If you press the front-panel **FORMAT** button when the AVG7 Generator module is selected (active), you can select the format for the output signals.

Perform the following steps to select the format:

1. Confirm that any menu item of the AVG7 module main menu is displayed. If the menu is not displayed, press the front-panel **MODULE** button until the AVG7 module main menu appears, as shown below.



```
AVG7 [x] : STATUS : NTSC
SMPTE Color Bars
```

2. Press the **FORMAT** button. The menu display changes as follows:

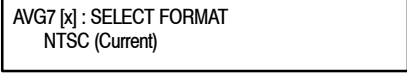

```
AVG7 [x] : SELECT FORMAT
NTSC (Current)
```

3. Press the left (◀) or right (▶) arrow button to select one of the signal formats, and then press the **ENTER** button to confirm the selection.

NOTE. When you change signal format, synchronization shock occurs.

When you change the format while a signal is output, the instrument starts loading all of the signal set for the format and displays the message “**Now Loading...**”. When you see the message, “**Done (Press CANCEL)**”, press the **CANCEL** button.

Selecting a Signal

All signal sets available in the module are already assigned to the corresponding test signal buttons (see Figure 2-1). When you press any of the buttons, one of the signals in the signal set is output.

For example, when you press the **COLOR BAR** test signal button, you can output the **100% Color Bars** signal in the Color Bars signal set.

Press the left (◀) or right (▶) arrow button, or press the test signal button repeatedly to select different signals assigned to the test signal button.

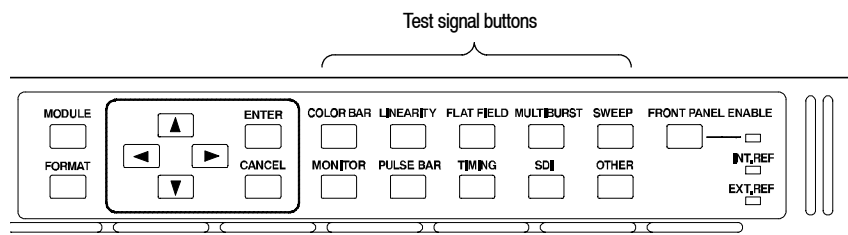

Figure 2-1: Front-panel test signal buttons

Table 2-1 lists the signal set assigned to each test signal button and the signals that can be selected in the signal set. The signals available in each signal set are different from one signal format to another. The signals in the signal set can be added or changed with improvement of the module.

Table 2-1: Signal set assigned to the test signal buttons

Button name	Signal set	Signals in the signal set
NTSC/NTSC No Setup format		
COLOR BAR	Color Bars	100% Color Bars, 75% Color Bars, SMPTE Color Bars
LINEARITY	Linearity	10 Step, 5 Step, Modulated 5 Step, Modulated Pedestal, Modulated Ramp, Shallow Ramp, Ramp
FLAT FIELD	Flat Fields	Black Burst, Black Burst with Field ref, 0% Flat Field (NTSC only), 10% Flat Field, 40 % Flat Field, 50% Flat Field, 100% Flat Field, Field Square Wave
MULTI BURST	Multi Burst	100% Multiburst, 60% Multiburst, Multipulse
SWEEP	Sweep	60% Sweep, 100% Sweep, Chroma Frequency Response
MONITOR	Monitor	Convergence Pattern, Gray Window, 100% Red Field, 2 Level Pedestal & Pluge, 4 Level Pedestal & Pluge, 75% Red Field, Monitor Setup, White Window, Safe Area
PULSE BAR	Pulse & Bar	Window 2T Pulse & Bar, Sin X/X
TIMING	-----	-----
SDI	-----	-----
OTHER	Other	FCC Composite, FCC Multiburst, Matrix 1, NTSC Combination, NTC7 Composite, SNG Color Bars

Table 2- 1: Signal set assigned to the test signal buttons (Cont.)

Button name	Signal set	Signals in the signal set
PAL-1 format		
COLOR BAR	Color Bars	100% Colour Bars, 75% Colour Bars, 100% Colour Bars Over Red, 75% Colour Bars Over Red
LINEARITY	Linearity	5 Step, Modulated 5 Step, Modulated Ramp, Ramp
FLAT FIELD	Flat Fields	Black Burst, 50% Flat Field, 100 % Flat Field, Field Square Wave
MULTI BURST	Multi Burst	60% Multiburst, Multipulse
SWEEP	Sweep	100% Sweep
MONITOR	Monitor	Convergence Pattern, Grey Window, White Window, 2 Level Pedestal & Pluge, 4 Level Pedestal & Pluge, 75% Red Field
PULSE BAR	Pulse & Bar	Window 2T Pulse & Bar, Sin X/X
TIMING	-----	-----
SDI	-----	-----
OTHER	Other	CCIR 17, CCIR 18, CCIR 330, CCIR 331, UK ITS 1, UK ITS 2
PAL-2 format		
COLOR BAR	Color Bars	100% Colour Bars, 75% Colour Bars
LINEARITY	Linearity	10 Step, 5 Step, Modulated 10 Step, Modulated 5 Step, Modulated Ramp, Shallow Ramp, Ramp, Modulated Pedestal
FLAT FIELD	Flat Fields	Black Burst, 50% Flat Field, 100 % Flat Field, Field Square Wave
MULTI BURST	Multi Burst	100% Multiburst, 60% Multiburst
SWEEP	Sweep	100% Sweep, 60% Sweep
MONITOR	Monitor	Convergence, Monitor Setup Matrix, 100% Red Field, 75% Red Field, White Window, Safe Area
PULSE BAR	Pulse & Bar	2T Pulse & Bar, Sin X/X
TIMING	-----	-----
SDI	-----	-----
OTHER	Other	ITS Matrix 1, UK 1 Line ITS

Table 2-1: Signal set assigned to the test signal buttons (Cont.)

Button name	Signal set	Signals in the signal set
525 Beta format		
COLOR BAR	Color Bars	100% Color Bars, 75% Color Bars
LINEARITY	Linearity	5 Step, Modulated Ramp, Ramp, Oversize Ramp, Shallow Ramp Matrix, Valid Ramp, Valid 5 Step
FLAT FIELD	Flat Fields	Black, 0% Flat Field, 100% Flat Field, 50% Flat Field, Field Square Wave
MULTI BURST	Multi Burst	60% Multiburst
SWEEP	Sweep	60% Sweep
MONITOR	Monitor	Convergence Pattern, Grey Window, White Window, 2 Level Ped. & Pluge, 4 Level Ped. & Pluge, 75% Red Field, Chroma Noise
PULSE BAR	Pulse & Bar	2T Pulse & Bar, TPulses
TIMING	Timing	50% Bowtie, 100% Bowtie
SDI	-----	-----
OTHER	Other	Test Matrix
525 GBR format		
COLOR BAR	Color Bars	100% Color Bars, 75% Color Bars
LINEARITY	Linearity	5 Step, Shallow Ramp, Oversize Ramp, Shallow Ramp Matrix, Luminance Ramp
FLAT FIELD	Flat Fields	0% Flat Field, 100% Flat Field, 50% Flat Field, Field Square Wave
MULTI BURST	Multi Burst	60% Multiburst
SWEEP	Sweep	100% Line Sweep 5.5 MHz, 100% Line Sweep 8 MHz
MONITOR	Monitor	Convergence Pattern, Grey Window, 2 Level Ped. & Pluge, White Window, 4 Level Ped. & Pluge
PULSE BAR	Pulse & Bar	2T Pulse & Bar
TIMING	Timing	Bowtie
SDI	-----	-----
OTHER	-----	-----

Table 2- 1: Signal set assigned to the test signal buttons (Cont.)

Button name	Signal set	Signals in the signal set
525 YPbPr format		
COLOR BAR	Color Bars	100% Color Bars, 75% Color Bars
LINEARITY	Linearity	5 Step, Ramp, Oversize Ramp, Shallow Ramp Matrix, Valid Ramp, Valid 5 Step, Modulated Ramp
FLAT FIELD	Flat Fields	Black, 0% Flat Field, 100% Flat Field, 50% Flat Field, Field Square Wave
MULTI BURST	Multi Burst	60% Multiburst
SWEEP	Sweep	60% Sweep
MONITOR	Monitor	Convergence Pattern, Grey Window, White Window, 2 Level Ped. & Pluge, 4 Level Ped. & Pluge, 75% Red Field, Chroma Noise
PULSE BAR	Pulse & Bar	2T Pulse & Bar, T Pulses
TIMING	Timing	50% Bowtie, 100% Bowtie
SDI	-----	-----
OTHER	Other	Test Matrix
625 YPbPr format		
COLOR BAR	Color Bars	100% Colour Bars, 75% Colour Bars, 100% Colour Bars Over Red, 75% Colour Bars Over Red
LINEARITY	Linearity	5 Step, Modulated Ramp, Ramp, Oversize Ramp, Shallow Ramp Matrix, Valid 5 Step, Valid Ramp
FLAT FIELD	Flat Fields	0% Flat Field, 100% Flat Field, 50 % Flat Field, Field Square Wave
MULTI BURST	Multi Burst	60% Multiburst
SWEEP	Sweep	60% Sweep
MONITOR	Monitor	Convergence Pattern, Grey Window, White Window, 2 Level Ped. & Pluge, 4 Level Ped. & Pluge, 100% Red, 75% Red
PULSE BAR	Pulse & Bar	2T Pulse & Bar, T Pulses
TIMING	Timing	50% Bowtie, 100% Bowtie
SDI	-----	-----
OTHER	Other	Test Matrix

Table 2- 1: Signal set assigned to the test signal buttons (Cont.)

Button name	Signal set	Signals in the signal set
625 GBR format		
COLOR BAR	Color Bars	100% Colour Bars, 75% Colour Bars
LINEARITY	Linearity	Oversize Ramp, Luminance Ramp, Shallow Ramp, Shallow Ramp Matrix, 5 Step
FLAT FIELD	Flat Fields	0% Flat Field, 50% Flat Field, 100% Flat Field, Field Square Wave
MULTI BURST	Multi Burst	60% Multiburst
SWEEP	Sweep	100% Sweep
MONITOR	Monitor	Convergence Pattern, Grey Window, 2 Level Ped. & Pluge, White Window, 4 Level Ped. & Pluge
PULSE BAR	Pulse & Bar	Window 2T Pulse & Bar
TIMING	Timing	Bowtie
SDI	-----	-----
OTHER	-----	-----

With the AVG7, you can download a frame picture file created by Frame Picture Generator to the TG700 Option FP and output the picture. Refer to *TG700 TV Signal Generator Platform User Manual* for detailed information on how to create, download, and output a frame picture.

AVG7 Module Main Menu

You can set the logo, circle, text overlay, timing offset, and APL feature of the signal outputs using the AVG7 module main menu.

Use the up (▲) or down (▼) arrow button to scroll through the main menu. Figure 2-2 shows the AVG7 module main menu.

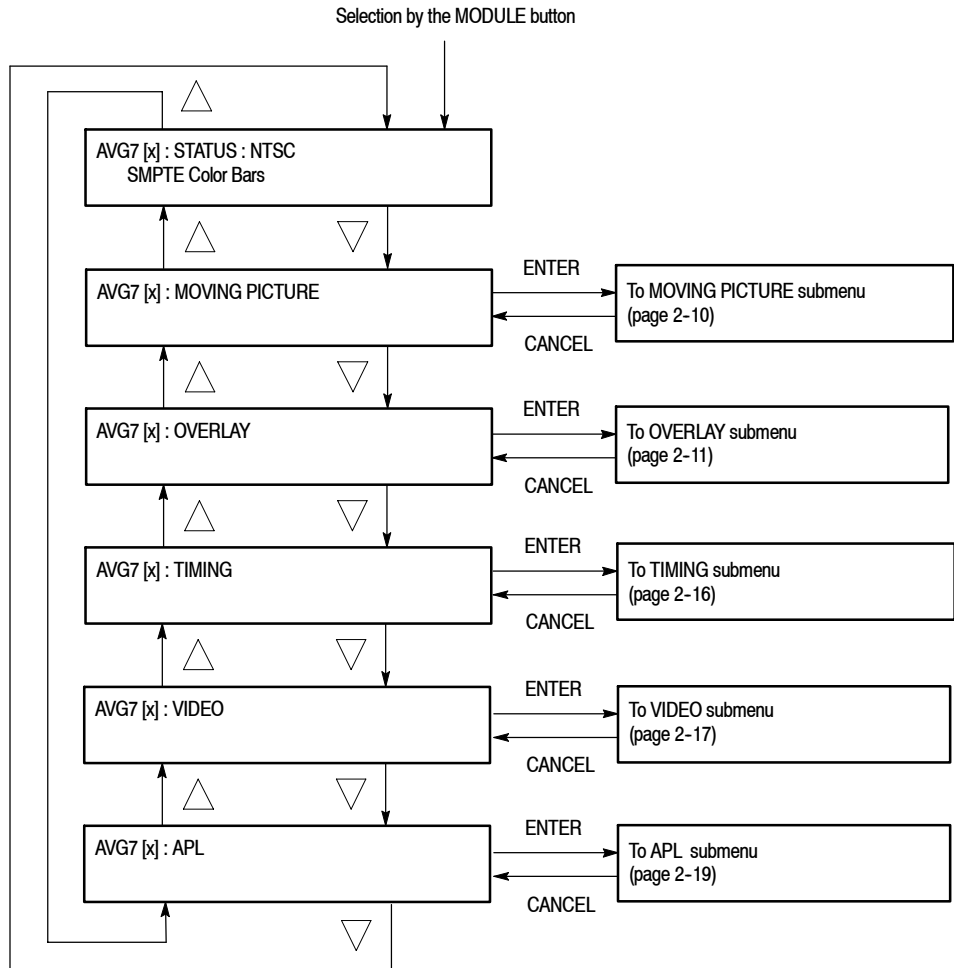

Figure 2-2: AVG7 module main menu

MOVING PICTURE. Scrolls the active picture area of the output test signal. When you select this menu item and then press the ENTER button, you will access the MOVING PICTURE submenu. Refer to *MOVING PICTURE Submenu* on page 2-10 for detailed information.

OVERLAY. Selects an item (logo, text, or circle) that is overlaid on the output test signal and sets the blinking mode for the overlay. When you select this menu item and then press the ENTER button, you will access the OVERLAY submenu. Refer to *OVERLAY Submenu* on page 2-11 for detailed information.

TIMING. Sets the timing offset of the output signals relative to the internal reference signal (frame reset signal). When you select this menu item and then press the ENTER button, you will access the TIMING submenu. Refer to *TIMING Submenu* on page 2-16 for detailed information.

VIDEO. Sets the output channel configuration when a composite signal is being output and enables or disables the signal output from CH 1, CH 2, and CH 3. When you select this menu item and then press the ENTER button, you will access the VIDEO submenu. Refer to *VIDEO Submenu* on page 2-17 for detailed information.

APL. Sets the APL and Bounce features available for the signal output. When you select this menu item and then press the ENTER button, you will access the APL submenu. Refer to *APL Submenu* on page 2-19 for detailed information.

**MOVING PICTURE
Submenu**

This menu allows you to scroll the active picture area of the output signal up/down or left/right (or randomly). Use the up (▲) or down (▼) arrow button to scroll the menu. Figure 2-3 shows the MOVING PICTURE submenu.

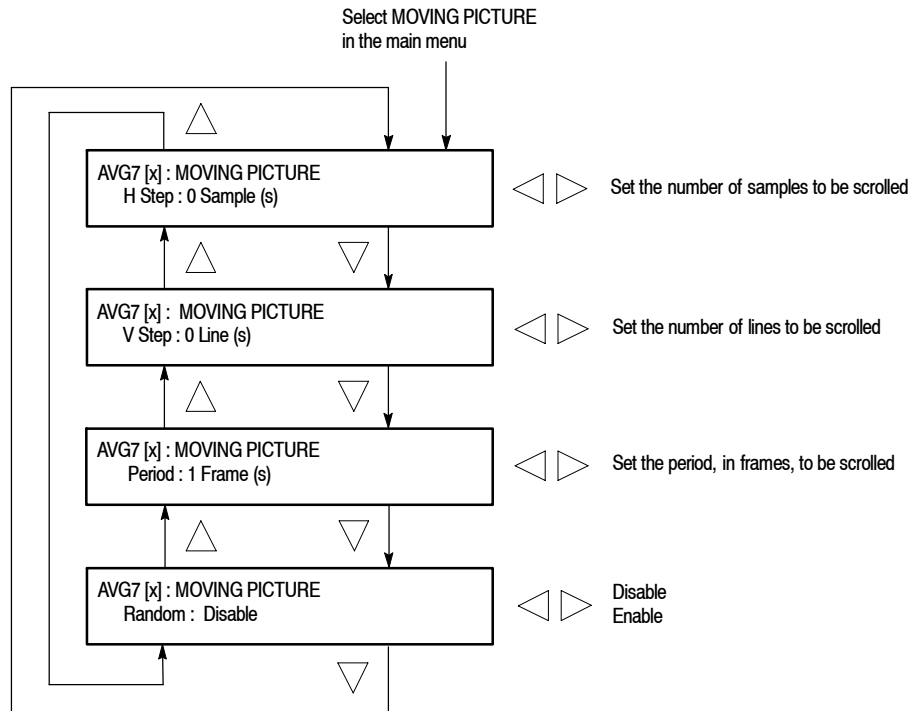

Figure 2-3: MOVING PICTURE submenu

- **H Step:** Sets the number of samples to be scrolled per frame set in the **Period** menu item. Use the left (◀) or right (▶) arrow button to change the value. You can set the value from -60 to +60 in 4 samples steps.
- **V Step:** Sets the number of lines to be scrolled per frame set in the **Period** menu item. Use the left (◀) or right (▶) arrow button to change the value. You can set the value from -15 to +15 in 1 line steps.
- **Period:** Sets the time interval between occurrences of the scrolling. Use the left (◀) or right (▶) arrow button to change the value. You can set the value from 1 to 16 in 1 frame steps.
- **Random:** Sets whether or not the picture scrolls randomly. Use the left (◀) or right (▶) arrow button to select between **Disable** and **Enable**. Press the **ENTER** button to confirm the selection.

OVERLAY Submenu

This menu allows you to select an item (logo, ID Text, or circle) to overlay on the output test signal, and to set the blinking mode for the overlay. Use the up (▲) or down (▼) arrow button to scroll through the menu. Figure 2-4 shows the OVERLAY submenu.

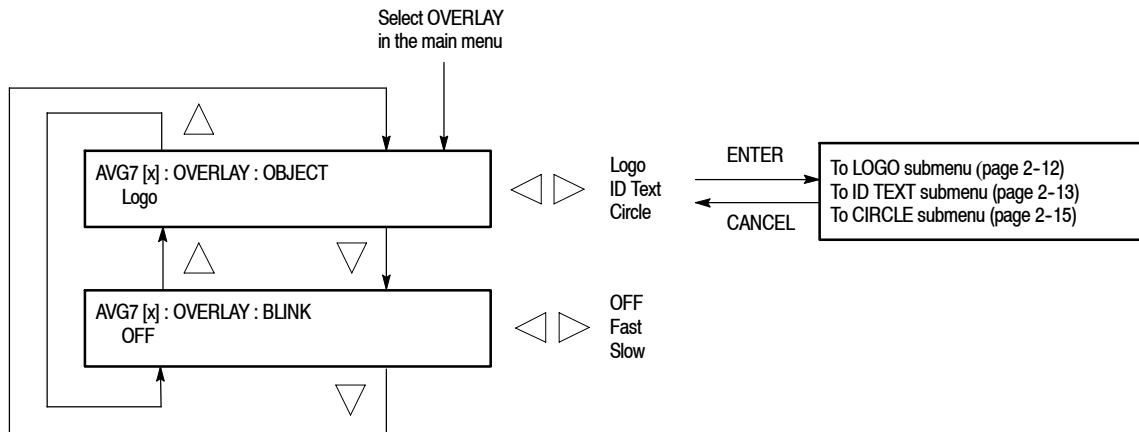

Figure 2-4: OVERLAY submenu

- OBJECT:** Selects an item that is overlaid on the output test signal. Use the left (◀) or right (▶) arrow button to select **Logo**, **ID Text**, or **Circle**. When you select any of these items and then press the ENTER button, you will access the submenu for setting that overlay. Refer to *LOGO Submenu* on page 2-12, *ID TEXT Submenu* on page 2-13, or *CIRCLE Submenu* on page 2-15 for detailed information.
- BLINK:** Sets the blinking mode for the overlay. Use the left (◀) or right (▶) arrow button to select **OFF**, **Fast** (blinks approximately at 0.5 second interval), or **Slow** (blinks approximately at 1.0 interval). Press the **ENTER** button to confirm the selection.

LOGO Submenu

This menu allows you to select a logo to overlay on the output test signal, and to set the display position of the logo. Use the up (▲) or down (▼) arrow button to scroll through the menu. Figure 2-5 shows the LOGO submenu.

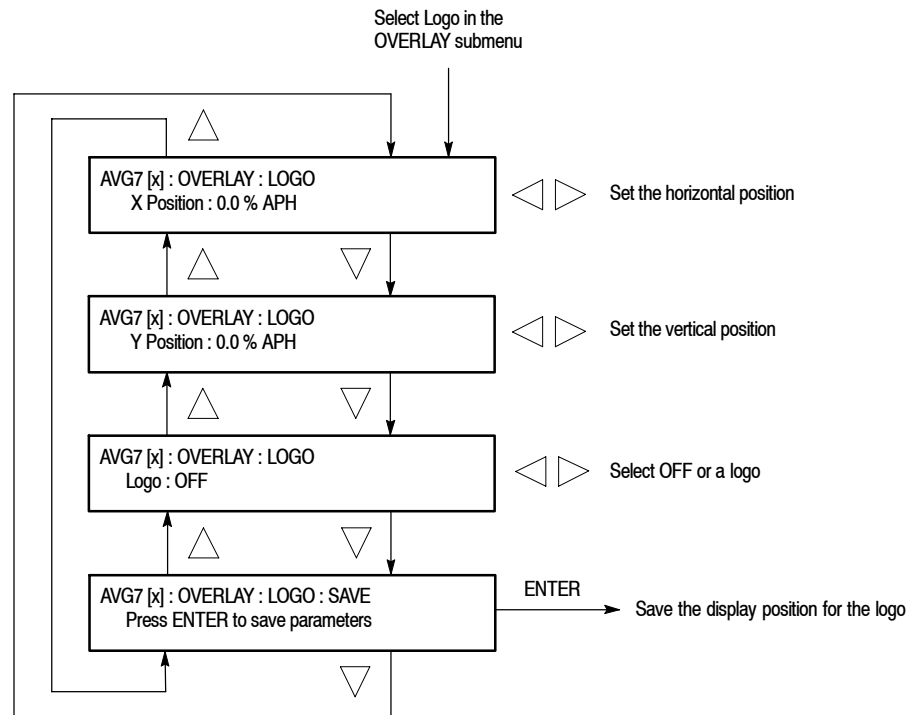

Figure 2-5: LOGO submenu

- **X Position:** Sets the horizontal position of the logo. The position is set as a percentage of active picture width. Use the left (◀) or right (▶) arrow button to change the position. You can set the value from -100.0% to 0.0% in 0.1% steps.
- **Y Position:** Sets the vertical position of the logo. The position is set as a percentage of active picture height. Use the left (◀) or right (▶) arrow button to change the position. You can set the value from -100.0% to 0.0% in 0.1% steps.
- **Logo:** Selects the logo you want to display. Use the left (◀) or right (▶) arrow button to select **OFF** or a logo file name. Press the **ENTER** button confirm the selection. When you select **OFF**, the logo overlay is disabled.
- **SAVE:** Saves the display position for the logo to the logo file. Press the **ENTER** button to save the current settings.

In order to display a logo using the LOGO submenu, you need to create the logo file (.lgo) and download it to the LOGO folder of the module.

Refer to the *TG700 TV Signal Generator Platform User Manual* for detailed information about how to create a logo file and download it to the TG700.

ID TEXT Submenu

This menu allows you to edit text that is overlaid on the output test signal, and to set the display position of the text. Use the up (▲) or down (▼) arrow button to scroll through the menu. Figure 2-6 shows the ID TEXT submenu.

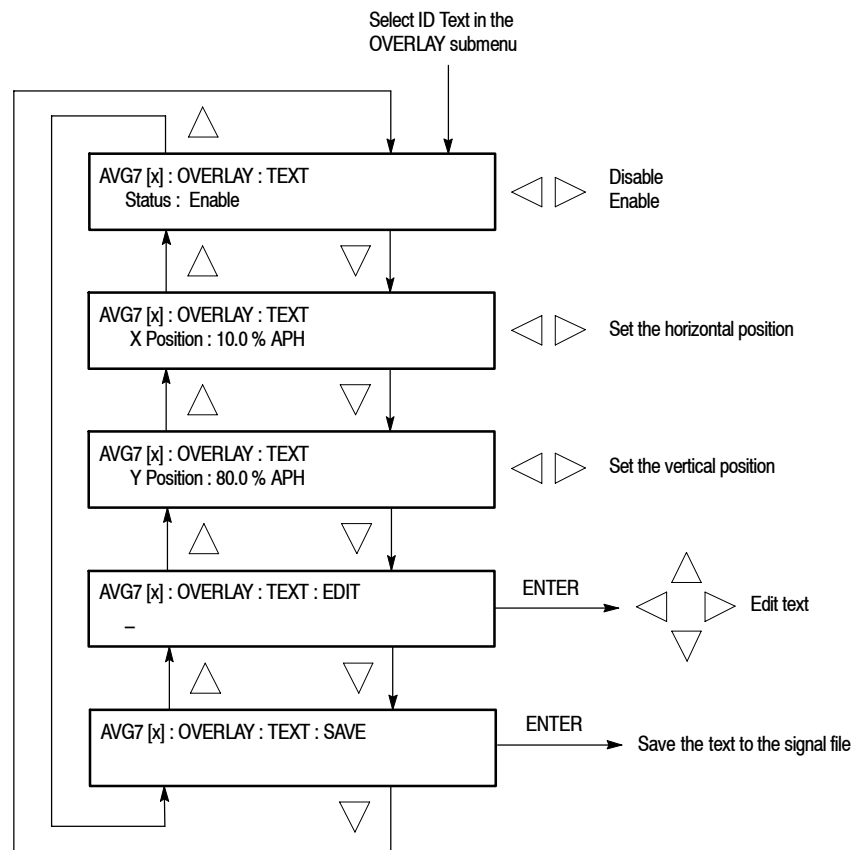

Figure 2-6: ID TEXT submenu

- **Status** : Enables or disables the text overlay. Use the left (◀) or right (▶) arrow button to select between **Enable** and **Disable**. Press the **ENTER** button to confirm the selection.
- **X Position**: Sets the horizontal position of the text. The position is set as a percentage of active picture width. Use the left (◀) or right (▶) arrow button to change the position. You can set the value from 0.0% to 100.0% in 1% steps.
- **Y Position**: Sets the vertical position of the text. The position is set as a percentage of active picture height. Use the left (◀) or right (▶) arrow button to change the position. You can set the value from 0.0% to 100.0% in 1% steps.
- **EDIT**: Edits the text you want to display on the output test signal.

To edit the text, first press the **ENTER** button to enable the text edit mode. Use the left (◀) or right (▶) arrow button to move the underscore character (_) to the character you want to change, and then use the up (▲) or down (▼) arrow button to select the desired character. When you enter all of the desired characters then press the **ENTER** button to end the text editing process. You can use up to 30 characters for the text. Use the blank character to erase an unneeded character(s).
- **SAVE**: Saves the text and its position to the signal file currently being output. Press the **ENTER** button to save the text and its position to the signal file.

CIRCLE Submenu

This menu allows you to create a circle overlaid on the output test signal and set its position on the display. Use the up (▲) or down (▼) arrow button to scroll through the menu. Figure 2-7 shows the CIRCLE submenu.

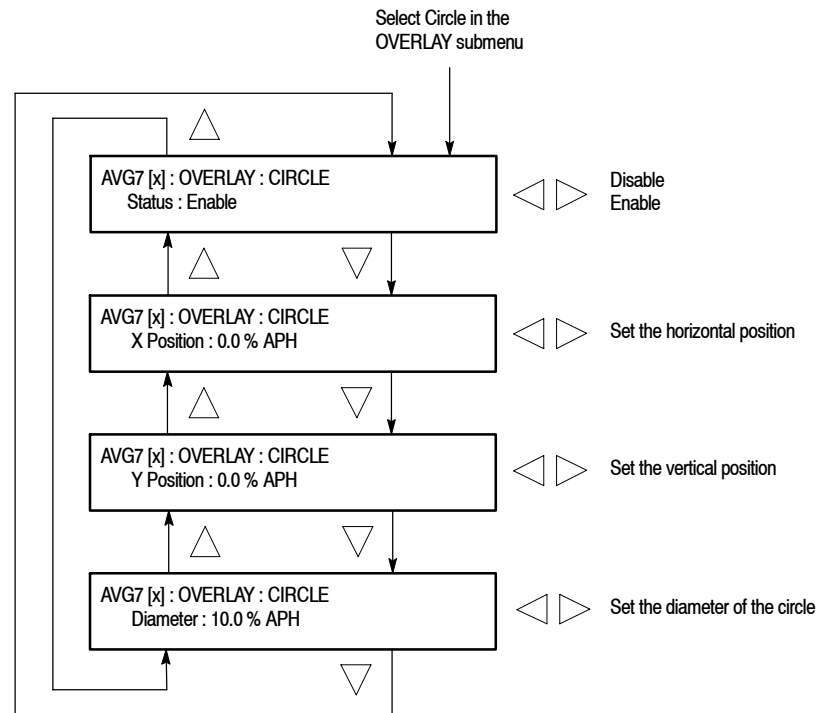

Figure 2-7: CIRCLE submenu

- **Status** : Enables or disables the circle overlay. Use the left (◀) or right (▶) arrow button to select between **Enable** and **Disable**. Press the **ENTER** button to confirm the selection.
- **X Position**: Sets the horizontal position of the circle. The position is set as a percentage of active picture width. Use the left (◀) or right (▶) arrow button to change the position. You can set the value from -50.0% to 50.0% in 1% steps.
- **Y Position**: Sets the vertical position of the circle. The position is set as a percentage of active picture height. Use the left (◀) or right (▶) arrow button to change the position. You can set the value from -50.0% to 50.0% in 1% steps.
- **Diameter**: Sets the diameter of the circle. The diameter is set as a percentage of active picture height. Use the left (◀) or right (▶) arrow button to change the value. You can set the value from 0.0% to 100.0% in 1% steps.

TIMING Submenu

This menu allows you to adjust the timing offset of the output signals relative to the internal reference signal (frame reset signal). Use the up (▲) or down (▼) arrow button to change the menu items. Figure 2-8 shows the TIMING submenu.

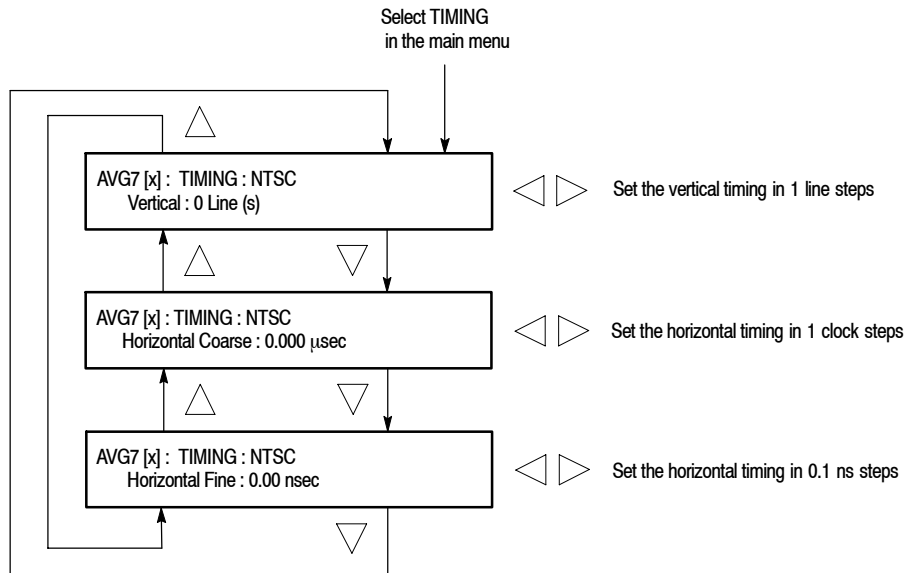

Figure 2- 8: TIMING submenu

- **Vertical:** Sets the vertical timing offset. Use the left (◀) or right (▶) arrow button to change the timing offset. You can set the value from -1 to +1 frame of the selected signal format in 1-line steps.
- **Horizontal Coarse:** Use the left (◀) or right (▶) arrow button to adjust the coarse horizontal offset. You can set the value from -1 to +1 line of the selected signal format in 1-clock (18.5 ns) steps.
- **Horizontal Fine:** Use the left (◀) or right (▶) arrow button to adjust the fine horizontal offset. You can set the value from -10 ns to +10 ns in 0.1 ns steps.

NOTE. You can reset the timing offset to zero by pressing the left (◀) and right (▶) arrow buttons simultaneously.

VIDEO Submenu

This menu allows you to set the output channel configuration when a composite signal is being output and to enable or disable the signal output of each channel. You can also set whether or not a sync signal is multiplexed with the B and R signal when a GBR signal is being output. Use the up (\blacktriangle) or down (\blacktriangledown) arrow button to scroll through the menu. Figure 2-9 shows the VIDEO submenu.

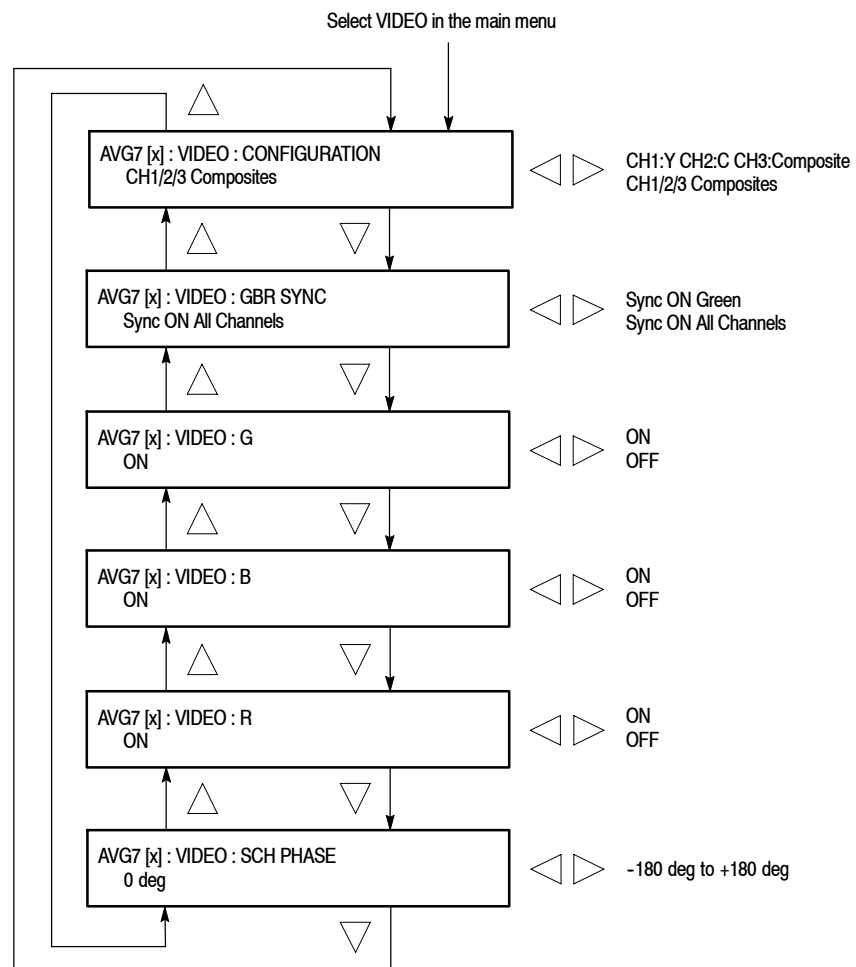

Figure 2-9: VIDEO submenu

- CONFIGURATION:** Sets the configuration of the output channels. Use the left (\blacktriangleleft) or right (\blacktriangleright) arrow button to select between **CH1:Y CH2:C CH3:Composite** and **CH1/2/3 Composites**. When you select CH1:Y CH2:C CH3:Composite, a Y signal, C signal, and composite signal are output from the CH 1, CH 2, and CH 3 connectors respectively. When you select CH1/2/3:Composites, a composite signal is output from each output connector. Press the **ENTER** button to confirm the selection. This menu item appears only when a composite signal is being output.

- **GBR SYNC:** Sets whether or not a sync signal is multiplexed with the B signal and R signal when a GBR signal is being output. Use the left (◀) or right (▶) arrow button to select between **Sync ON Green** and **Sync ON All Channels**. When you select Sync ON All Channels, a sync signal is multiplexed with the G, B, and R signals. Press the **ENTER** button to confirm the selection. This menu item appears only when a GBR signal is being output.
- **G/Y:** Turns the CH 1 signal output on or off for a component signal, or turns the Y signal on or off for a composite signal.. Use the left (◀) or right (▶) arrow button to select between **ON** and **OFF**. Press the **ENTER** button to confirm the selection. The signal name displayed depends on the video format of the currently selected signal (YPbPr component, GBR component, or composite) and the output channel configuration.
- **B/Pb/B-Y:** Turns the CH 2 signal output on or off for a component signal, or turns the B-Y signal on or off for a composite signal. Use the left (◀) or right (▶) arrow button to select between **ON** and **OFF**. Press the **ENTER** button to confirm the selection. The signal name displayed depends on the video format of the currently selected signal (YPbPr component, GBR component, or composite) and the output channel configuration.
- **R/Pr/R-Y:** Turns the CH 3 signal output on or off for a component signal, or turns the R-Y signal on or off for a composite signal. Use the left (◀) or right (▶) arrow button to select between **ON** and **OFF**. Press the **ENTER** button to confirm the selection. The signal name displayed depends on the video format of the currently selected signal (YPbPr component, GBR component, or composite) and the output channel configuration.
- **SCH PHASE:** Use the left (◀) or right (▶) arrow button to adjust the SCH phase for a composite signal. You can set the value from -180 degrees (°) to +180 degrees (°) in 1 degree (°) steps. This setting is not saved a preset.

NOTE. *If you try to set the SCH phase over +180 degrees, the value jumps to -179 degrees. Also, if you try to set the SCH phase under -180 degrees, the value jumps to +179 degrees.*

APL Submenu

This menu allows you to set the APL and Bounce features for the test signal outputs. Use the up (▲) or down (▼) arrow button to scroll through the menu. Figure 2-10 shows the APL submenu.

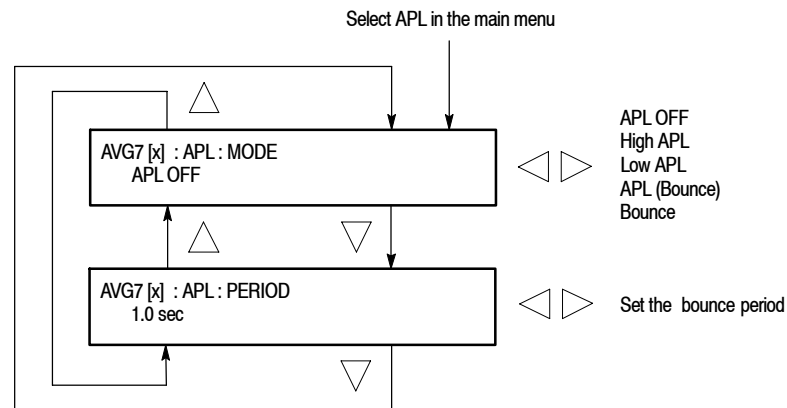

Figure 2-10: APL submenu

- **MODE** : Sets the output mode of the APL signal. Use the left (◀) or right (▶) arrow button to select the mode. The choices are:
 - **APL OFF** : Outputs the selected signal without making any changes.
 - **High APL** : Divides the video lines of the selected signal into 5 lines (for NTSC) or 4 lines (for PAL) and changes the lines except the last line to the 100% flat field signal, and then outputs them.
 - **Low APL** : Divides the video lines of the selected signal into 5 lines (for NTSC) or 4 lines (for PAL) and changes the lines except the last line to the 0% flat field signal, and then outputs them.
 - **APL (Bounce)** : Outputs the High APL signal and Low APL signal alternately for the period set in the PERIOD menu item.
 - **Bounce** : Outputs the 100% flat field signal and 0% flat field signal alternately (regardless of the selected signal) for the period set in the PERIOD menu item.

Press the **ENTER** button to confirm the selection.

- **PERIOD** : Sets the time interval between two signals when they are output in APL (Bounce) or Bounce mode. Use the left (◀) or right (▶) arrow button to change the interval. You can set the value from 0.5 seconds to 2.0 seconds in 0.5 second steps.

Rear-Panel Connectors

The AVG7 Generator module is equipped with six connectors: one pair of **CH 1**, **CH 2**, and **CH 3**, which will output analog component or composite test signals. Figure 2-11 shows the AVG7 Generator module rear-panel connectors.

NOTE. Each pair of connectors (CH 1, CH 2, and CH 3) will both output the same test signal.

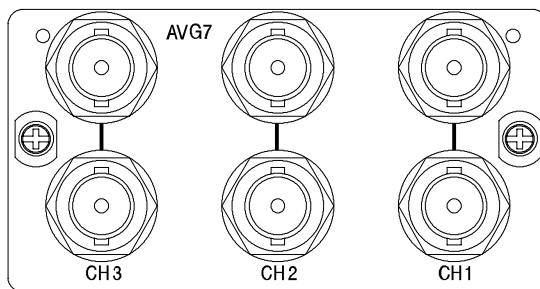

Figure 2- 11: AVG7 module rear-panel connectors

- **CH 1:** Analog component or composite test signal output.
- **CH 2:** Analog component or composite test signal output.
- **CH 3:** Analog component or composite test signal output.

Factory Default Settings

Table 2-2 shows the factory default settings for the AVG7 Generator module. These settings are recalled when you select **Factory Default** from the **PRESET : RECALL** menu item in the mainframe main menu.

Table 2-2: Factory default settings

Menu item name	Settings
STATUS	NTSC SMPTE Color Bars
MOVING PICTURE	
H Step	0 Sample(s)
V Step	0 Line(s)
Period	1 Frame(s)
Random	Disable
OVERLAY : OBJECT	Logo
OVERLAY : BLINK	OFF
OVERLAY : LOGO	
Logo	OFF
OVERLAY : ID TEXT	
Status	Disable
OVERLAY : CIRCLE	
Status	Disable
X Position	0.0% APH
Y Position	0.0% APH
Diameter	90% APH
TIMING	
Vertical	0 Line(s)
Horizontal Coarse	0.0000 μ s
Horizontal Fine	0.00 ns

Table 2-2: Factory default settings (Cont.)

Menu item name	Settings
VIDEO	
CONFIGURATION	CH1/2/3 Composites
GBR SYNC	Sync ON All Channels
G/Y	ON
B/Pb/B-Y	ON
R/Pr/R-Y	ON
SCH PHASE	0 deg
APL	
MODE	APL OFF
PERIOD	1.0 s



Reference

Syntax

This section contains information on the Standard Commands for Programmable Instruments (SCPI) and the programming structure you can use to program your AVG7 Generator module.

Programming Model

Specific conditions must exist before programming commands will affect the test signal generated by a module.

Selecting the Module

Select the module using the :INSTRument:SElect command before executing any commands. Many of the commands used by the AVG7 module are shared by several modules and will be accepted without a reported error.

Command Arguments

Many commands will accept either string or numeric arguments. For example: a boolean argument can either be “1” or “ON”.

Signal parameter commands that have a :STEP node can accept either a numeric value or they can accept a string argument that refers to the :STEP increment.

Signal parameter commands with a :STEP node will accept the following strings in addition to a numeric value:

UP. Use this argument to increase the parameter value one increment as defined by the :STEP value.

DOWN. Use this argument to decrease the parameter value one increment as defined by the :STEP value.

MINimum. Use this argument to set the parameter value to the minimum acceptable value.

MAXimum. Use this argument to set the parameter value to the maximum acceptable value.

DEFault. Use this argument to set the parameter value to the default value.

Query Arguments

If you send a query with no argument, the response is the current value. You can also use **MINimum**, **MAXimum**, and **DEFault** as arguments for queries whose command form can use these arguments (refer to the command syntax for the specific command). Instead of returning the current value, queries using these arguments return the following information:

MINimum. Return the minimum acceptable value.

MAXimum. Return the maximum acceptable value.

DEFault. Return the default value.

Argument Example

The following example demonstrates the effect of each of the arguments when used with a step value.

1. `:INSTRument:SElect "AVG7:#"` selects the AVG7 Generator module located in the slot number indicated by the “#” symbol.
2. `:OUTPut:CIRClE:STATe ON` displays a circle on the video display.

NOTE. `:OUTPut:CIRClE:DIAMeter` uses an argument that is the percent of picture height.

3. `:OUTPut:CIRClE:DIAMeter DEFaul t` sets the circle diameter to 90 percent of the screen height.
4. `:OUTPut:CIRClE:DIAMeter:STEP 10` sets the step increment to 10 percent.
5. `:OUTPut:CIRClE:DIAMeter DOWN` changes the circle diameter to 80 percent of the screen height.
6. `:OUTPut:CIRClE:DIAMeter 50` changes the circle diameter to 50 percent of the screen height.
7. `:OUTPut:CIRClE:DIAMeter MAXimum` changes the circle diameter to 100 percent of the screen height.
8. `:OUTPut:CIRClE:DIAMeter MINimum` changes the circle diameter to 0 percent of the screen height.
9. `:OUTPut:CIRClE:DIAMeter UP` changes the circle diameter to 10 percent of the screen height.
10. `:OUTPut:CIRClE:DIAMeter? MAXimum` queries the maximum circle diameter (not the current diameter). The query returns the value of 100 percent, which is the maximum circle diameter allowable.

SCPI Commands and Queries

SCPI is a standard created by a consortium that provides guidelines for remote programming of instruments. These guidelines provide a consistent programming environment for instrument control and data transfer. This environment uses defined programming messages, instrument responses, and data format across all SCPI instruments, regardless of manufacturer. The AVG7 Generator module uses a command language based on the SCPI standard.

The SCPI language is based on a hierarchical or tree structure (see Figure 3-1) that represents a subsystem. The top level of the tree is the root node; it is followed by one or more lower-level nodes.

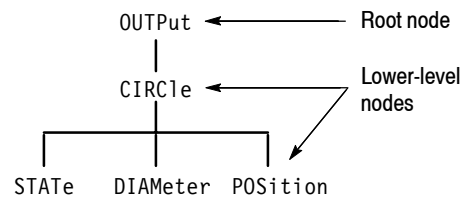

Figure 3-1: Example of SCPI subsystem hierarchy

You can create commands and queries from these subsystem hierarchy trees. Commands specify actions for the instrument to perform. Queries return measurement data and information about parameter settings.

For more information on SCPI commands and programming structure, refer to the *TG700 Signal Generator Platform User Manual*.

Remote Commands

This section describes the remote commands used to control the AVG7 Generator module remotely. The commands to the module are divided into the following three groups:

- MASS MEMORY commands (Refer to the *TG700 TV Signal Generator Platform User Manual*)
- OUTPUT commands
- SENSE commands

MASS MEMORY Commands

Two MASS MEMORY commands are listed here for your reference. You can use these to load and query the output test signal. Detailed information for using these commands are located in the *TG700 TV Signal Generator Platform User Manual*.

```
:MMEmory:LOAD:SIGNa1 <module_name>,<signal_name>  
:MMEmory:LOAD:SIGNa1 <slot_number>,<signal_name>
```

Loads a signal into the specified module.

```
:MMEmory:SIGNa1:ACTive? <slot_number>|<module_name>
```

Returns the current output signal of the specified module.

OUTPUT Commands

Use these commands to control the output parameters of the module. These include output status and circle/text/logo overlay.

Command Tree

```
:OUTPut<n>
  :STATe          ON|OFF
  :CIRClE
    :STATe        ON|OFF
    :DIAMeter     <numeric_value>
    :POSition
      :HORizontal <numeric_value>
      :VERTical   <numeric_value>
  :LOGO
    :STATe        ON|OFF
    :POSition
      :HORizontal <numeric_value>
      :VERTical   <numeric_value>
    :SElect       <logo_name>
    :SAVe
  :TEXT
    :STATe        ON|OFF
    :DATA         <string>
    :POSition
      :HORizontal <numeric_value>
      :VERTical   <numeric_value>
    :SAVe
  :OVERlay
    :BLINK
      :STATe      ON|OFF
      :PERiod     <numeric_value>
  :APL
    :MODE         APL_OFF|APL_HIGH|APL_LOW|APL_BOUNCE
    :PERiod       <numeric_value>
  :MOVE
    :HORizontal   <numeric_value>
    :VERTical     <numeric_value>
    :PERiod       <numeric_value>
    :RANDom[:STATe] ON|OFF
  :VIDeo
    :CONFig       YC|COMPOSITE
    :SCH          <numeric_value>
    :SYNC
      :STATe      ON|OFF
```

Command Description

`:OUTPut<n>:STATe ON|OFF`

Turns the signal output of the specified channel on or off. The <n> in the command represents the output channel and you can specify 1, 2, or 3. You can use 1 or 0 instead of ON or OFF.

`:OUTPut<n>:STATe?`

Returns the current output state of the specified channel. The <n> in the command represents the output channel and you can specify 1, 2, or 3.

`:OUTPut1:CIRClE:STATe ON|OFF`

Turns the circle overlay on the video signal on or off. You can use 1 or 0 instead of ON or OFF.

`:OUTPut1:CIRClE:STATe?`

Returns the current circle overlay state.

`:OUTPut1:CIRClE:DIAMeter <numeric_value>`

Sets the diameter of the displayed circle. The unit is the percent of active picture height. You can set the diameter from 0% to 100% in 1% steps. You can also use MIN, MAX, or DEF instead of a numeric value.

`:OUTPut1:CIRClE:DIAMeter?`

Returns the diameter of the displayed circle.

`:OUTPut1:CIRClE:POSition:HORizontal <numeric_value>`

Sets the horizontal position of the circle as it appears on the active signal. The unit is the percent of active picture width. You can set the position from -50% to +50% in 1% steps. You can also use MIN, MAX, or DEF instead of a numeric value.

`:OUTPut1:CIRClE:POSition:HORizontal?`

Returns the current horizontal position of the circle as it appears on the active signal.

`:OUTPut1:CIRClE:POSition:VERTical <numeric_value>`

Sets the vertical position of the circle as it appears on the active signal. The unit is the percent of active picture height. You can set the position from -50% to +50% in 1% steps. You can also use MIN, MAX, or DEF instead of a numeric value.

`:OUTPut1:CIRClE:POSition:VERTical?`

Returns the current vertical position of the circle as it appears on the active signal.

`:OUTPut1:LOG0:STATe ON|OFF`

Turns the logo overlay on the video signal on or off. You can use 1 or 0 instead of ON or OFF.

`:OUTPut1:LOG0:STATe?`

Returns the current logo overlay state.

`:OUTPut1:LOG0:POSition:HORizontal <numeric_value>`

Sets the horizontal position of the logo as it appears on the active signal. The unit is the percent of active picture width. You can set the position from -100% to 0% in 0.1% steps. You can also use MIN, MAX, or DEF instead of a numeric value.

`:OUTPut1:LOG0:POSition:HORizontal?`

Returns the current horizontal position of the logo.

`:OUTPut1:LOG0:POSition:VERTical <numeric_value>`

Sets the vertical position of the logo as it appears on the active signal. The unit is the percent of active picture height. You can set the position from -100% to 0% in 0.1% steps. You can also use MIN, MAX, or DEF instead of a numeric value.

`:OUTPut1:LOG0:POSition:VERTical?`

Returns the current vertical position of the logo.

`:OUTPut1:LOG0:SElect <logo_name>`

Selects the logo used for the logo overlay.

`:OUTPut1:LOG0:SElect?`

Returns the current logo used for the logo overlay.

`:OUTPut1:LOG0:SAVe`

Saves the current display position of the logo to the logo file. There are no arguments.

`:OUTPut1:TEXT:STATe ON|OFF`

Turns the text overlay on the video signal on or off. You can use 1 or 0 instead of ON or OFF.

:OUTPut1:TEXT:STATe?

Returns the current text overlay state.

:OUTPut1:TEXT:DATA <string>

Sets the current string for the text mode.

:OUTPut1:TEXT:DATA?

Returns the current string for the text mode.

:OUTPut1:TEXT:POSition:HORizontal <numeric_value>

Sets the text horizontal position in the video signal. The unit is the percent of active picture width. You can set the position from 0% to 100% in 1% steps. You can also use MIN, MAX, or DEF instead of the numeric value.

:OUTPut1:TEXT:POSition:HORizontal?

Returns the current text horizontal position in the video signal.

:OUTPut1:TEXT:POSition:VERTical <numeric_value>

Sets the text vertical position in the video signal. The unit is the percent of active picture height. You can set the position from 0.0% to 100.0% in 1% steps. You can also use MIN, MAX, or DEF instead of the numeric value.

:OUTPut1:TEXT:POSition:VERTical?

Returns the current text vertical position in the video signal.

:OUTPut1:TEXT:SAVe

Saves the current text and its display position to the signal file. There are no arguments.

:OUTPut1:OVERlay:BLINK:STATe ON|OFF

Turns on or off the blinking mode for the logo, text, and circle overlay. You can also use 1 or 0 instead of ON or OFF

:OUTPut1:OVERlay:BLINK:STATe?

Returns the current state of the blinking mode for the logo, text, and circle overlay.

:OUTPut1:OVERlay:BLINK:PERiod <numeric_value>

Sets the blinking interval of the blinking mode for the logo, text, and circle overlay. You can set the value as 0.5 seconds or 1.0 seconds.

:OUTPut1:OVERlay:BLINK:PERiod?

Returns the blinking interval of the blinking mode for the logo, text, and circle overlay.

:OUTPut1:APL:MODE APL_OFF|APL_HIGH|APL_LOW|APL_BOUNCE|BOUNCE

Sets the output mode of the APL signal. Refer to *APL Submenu* on page 2-19 for detailed information about the each mode.

:OUTPut1:APL:MODE?

Returns the current output mode of the APL signal.

:OUTPut1:APL:PERiod <numeric_value>

Sets the time interval between two signals when they are output in the bounce modes. You can set the value from 0.5 seconds to 2.0 seconds in 0.5 seconds steps.

:OUTPut1:APL:PERiod?

Returns the time interval between two signals when they are output in the bounce modes.

:OUTPut1:MOVE:HORizontal <numeric_value>

Sets the amount of horizontal scrolling in the moving picture mode. You can set the value from -252 to +252 in 4 samples steps.

:OUTPut1:MOVE:HORizontal?

Returns the amount of horizontal scrolling in the moving picture mode.

:OUTPut1:MOVE:VERTical <numeric_value>

Sets the amount of vertical scrolling in the moving picture mode. You can set the value from -252 to +252 in 1 line steps.

:OUTPut1:MOVE:VERTical?

Returns the amount of vertical scrolling in the moving picture mode.

:OUTPut1:MOVE:PERiod <numeric_value>

Sets the time interval between occurrences of the scrolling. You can set the value from 1 to 16 in 1 field steps.

:OUTPut1:MOVE:PERiod?

Returns the time interval between occurrences of the scrolling.

:OUTPut1:MOVE:RANDom:STATe ON|OFF

Turns the random scrolling mode on or off. You can also use 1 or 0 instead of ON or OFF.

:OUTPut1:MOVE:RANDom:STATe?

Returns the current state of the random scrolling mode.

:OUTPut1:VIDeo:CONFig YC|COMPOSITE

Sets the output channel configuration when a composite signal is being output. For YC, a Y signal, C signal, and composite signal will be assigned to CH1, CH2, and CH3 respectively. For COMPOSITE, a composite signal will be assigned to all the three channels.

:OUTPut1:VIDeo:CONFig?

Returns the current setting of the output channel configuration when a composite signal is being output.

:OUTPut1:VIDeo:SCH <numeric_value>

Sets the SCH phase for a composite signal. You can set the value from -180 degrees to +180 degrees in 1 degree steps.

:OUTPut1:VIDeo:SCH?

Returns the current SCHphase setting.

:OUTPut1:VIDeo:SYNC:STATe ON|OFF

Sets whether or not a sync signal is multiplexed with the B and R signals when a GBR signal is being output. You can also use 1 or 0 instead of ON or OFF.

:OUTPut1:VIDeo:SYNC:STATe?

Returns whether or not a sync signal is multiplexed with the B and R signals when a GBR signal is being output.

SENSE Commands

Use these commands to set the timing offset of the output signals relative to the internal reference signal (frame reset signal).

Refer to *Operating Basics* for detailed information about the setting range.

Command Tree

```
:SENSe<n>
  :CORRection
    :MDElay
      :HORizontal    <numeric_value>
        :STEP        <numeric_value>
      :VERTical      <numeric_value>
        :STEP        <numeric_value>
```

Command Description

`:SENSe1:CORRection:MDElay:HORizontal <numeric_value>`

Sets the horizontal timing offset of the output signals. The timing resolution is clock-cycles. The units are microseconds. You can use UP, DOWN, or DEF instead of the numeric value. If the argument exceeds the horizontal time value, then the vertical offset is adjusted to accommodate the requested delay.

`:SENSe1:CORRection:MDElay:HORizontal?`

Returns the current horizontal timing offset of the output signals.

`:SENSe1:CORRection:MDElay:HORizontal:STEP <numeric_value>`

Sets the step increment used by the UP or DOWN commands. The units are microseconds. You can use MIN, MAX, or DEF instead of a numeric value.

`:SENSe1:CORRection:MDElay:HORizontal:STEP?`

Returns the current step increment.

`:SENSe1:CORRection:MDElay:VERTical <numeric_value>`

Sets the vertical timing offset of the output signals. The argument can be a floating point value that is translated into integer lines with a horizontal offset. You can use UP, DOWN, or DEF instead of a numeric value.

:SENSe1:CORRection:MDELay:VERTical?

Returns the current vertical timing offset of the output signals.

:SENSe1:CORRection:MDELay:VERTical:STEP <numeric_value>

Sets the step increment used by the UP or DOWN commands. You can use MIN, MAX, or DEF instead of a numeric value.

:SENSe1:CORRection:MDELay:VERTical:STEP?

Returns the current step increment.



Appendices

Appendix A: Specifications

Tables A-1 through A-3 list the electrical and environmental characteristics of the AVG7 Generator module.

Electrical Characteristics

Table A-1: Output channels

Characteristic	Performance requirements	Reference information
Channel 1 (CH 1)		
Number of outputs	2	
Output signals	Y, G, or composite	Each component of a composite signal can be turned On or Off using the VIDEO submenu.
Channel 2 (CH 2)		
Number of outputs	2	
Output signals	B-Y, Pb, B, C, or composite	Each component of a composite signal can be turned On or Off using the VIDEO submenu.
Channel 3 (CH 3)		
Number of outputs	2	
Output signals	R-Y, Pr, R, or composite	Each component of a composite signal can be turned On or Off using the VIDEO submenu.

Table A-2: Common output characteristics

Characteristic	Performance requirements	Reference information
Amplitude error		
Absolute amplitude	$\leq 1\%$	Measured at 700 mV.
Channel gain matching	$\leq 0.5\%$	Measured at 700 mV, relative to CH 1.
Chrominance to luminance gain	$\leq 1\%$	Measured at 700 mV, relative to 500 kHz.

Table A-2: Common output characteristics (cont.)

Characteristic	Performance requirements	Reference information
Delay error		
Chrominance to luminance delay, typical		≤ 2.5 ns on a composite output.
Channel to channel delay	≤ 1 ns	Relative to CH 1
Group delay, typical		≤ 5 ns to 5 MHz
SCH Phase error, typical		≤ 1.25 ns ($\pm 1.6^\circ$ at 3.58 MHz and $\pm 2^\circ$ at 4.43 MHz)
Frequency response	Flat within 0.5% peak from 0.5 MHz to 5 MHz.	Typically $\leq 5\%$ to 8 MHz at 700 mV, measured with a 1 m coax cable and peak detector.
Line time distortion	$\leq 0.5\%$	Measured with FCC composite signal.
Field time distortion	$\leq 0.5\%$	Measured with field square wave.
K factor 2T5 pulse	$\leq 0.5\%$	
Pulse/bar ratio, typical		1:1 within 0.5 % with 2T5 pulse and bar signal.
DC offset	≤ 10 mV	
Differential gain	$\leq 0.5\%$	
Differential phase	$\leq 0.5^\circ$	
Return loss	≥ 40 dB to 6 MHz	

Environmental Characteristics

Table A-3: Environmental characteristics

Characteristic	Description
Temperature	
Operating	0 °C to +50 °C
Non-operating	-20 °C to +60 °C
Relative Humidity	
Operating	20% to 80% (No condensation); Maximum wet-bulb temperature 29.4 °C
Non-operating	5% to 90% (No condensation); Maximum wet-bulb temperature 40.0 °C
Altitude	
Operating	To 4.5 km (15 000 feet) Maximum operating temperature decreases 1 °C each 300 m above 1.5 km.
Non-operating	To 15 km (50 000 feet)
Vibration	
Operating	2.65 m/s ² (0.27 G _{rms}), 5 Hz to 500 Hz, 10 min, three axes
Non-operating	22.36 m/s ² (2.28 G _{rms}), 5 Hz to 500 Hz, 10 min, three axes
Shock	
Non-operating	588 m/s ² (60 G), half-sine, 11 ms duration



Index

Index

A

- Accessories
 - optional, 1-2
 - standard, 1-2
- Adjusting the SCH phase, 2-18
- APL, 2-19
- APL submenu, 2-19
- AVG7 features, 1-1
- AVG7 module main menu, 2-8
 - APL, 2-9
 - MOVING PICTURE, 2-9
 - OVERLAY, 2-9
 - TIMING, 2-9
 - VIDEO, 2-9

B

- Bounce, 2-19

C

- CH 1 connector, 2-20
- CH 2 connector, 2-20
- CH 3 connector, 2-20
- Circle overlay, 2-15
- CIRCLE submenu, 2-15
- Commands
 - Rules for forming, 3-1
 - Syntax, 3-1

E

- Electrical specifications, A-1
- Environmental specifications, A-3

F

- Factory default settings, 2-21
- functional check, 1-2

H

- Hierarchy (SCPI), 3-3

I

- ID TEXT submenu, 2-13
- Installation, 1-2

L

- Logo overlay, 2-12
- LOGO submenu, 2-12

M

- Manuals, Related, iii
- MASS MEMORY commands, 3-5
- MOVING PICTURE submenu, 2-10

O

- Operating procedure, 2-1
- Option, 1-2
- Optional accessories, 1-2
- OUTPUT commands, 3-6
- OVERLAY submenu, 2-11

P

- Product description, 1-1

R

- Rear-panel connectors, 2-20
- Related Manuals, iii
- Remote commands, 3-5
- Rules, Command forming, 3-1

S

- SCPI, Subsystem hierarchy tree, 3-3
- SCPI commands and queries syntax, 3-3-3-4
- Signal set assigned to the test signal buttons, 2-3
- Specifications
 - Electrical, A-1
 - Environmental, A-3

Standard accessories, 1-2
Syntax, Command, 3-1

T

Text overlay, 2-13

TIMING submenu, 2-16

V

VIDEO submenu, 2-17

User Manual



AWVG7 Analog Wideband Video Generator

Copyright © Tektronix. All rights reserved. Licensed software products are owned by Tektronix or its suppliers and are protected by United States copyright laws and international treaty provisions.

Tektronix products are covered by U.S. and foreign patents, issued and pending. Information in this publication supercedes that in all previously published material. Specifications and price change privileges reserved.

TEKTRONIX and TEK are registered trademarks of Tektronix, Inc.

Contacting Tektronix

Tektronix, Inc.
14200 SW Karl Braun Drive
P.O. Box 500
Beaverton, OR 97077
USA

For product information, sales, service, and technical support:

- In North America, call 1-800-833-9200.
- Worldwide, visit www.tektronix.com to find contacts in your area.

Table of Contents

Preface	iii
About This Manual	iii
Related Manuals	iii
Getting Started	
Product Description	1-1
Accessories	1-2
Option	1-2
Installation	1-3
Functional Check	1-3
Operating Basics	
Operating Procedure	2-1
Selecting an Output Signal	2-2
AWVG7 Module Main Menu	2-4
Rear-Panel Connectors	2-15
Factory Default Settings	2-16
Reference	
Syntax	3-1
Programming Model	3-1
SCPI Commands and Queries	3-3
Remote Commands	3-5
MASS MEMORY Commands	3-5
OUTPUT Commands	3-6
SENSE Commands	3-11
Appendices	
Appendix A: Specifications	A-1
Electrical Characteristics	A-1
Environmental Characteristics	A-2
Index	

List of Figures

Figure 2-1: Front-panel test signal buttons	2-3
Figure 2-2: AWVG7 module main menu	2-4
Figure 2-3: MOVING PICTURE submenu	2-6
Figure 2-4: OVERLAY submenu	2-7
Figure 2-5: LOGO submenu	2-8
Figure 2-6: ID TEXT submenu	2-9
Figure 2-7: CIRCLE submenu	2-11
Figure 2-8: TIMING submenu	2-12
Figure 2-9: VIDEO submenu	2-14
Figure 2-10: AWVG7 Generator module rear-panel connectors ...	2-15
Figure 3-1: Example of SCPI subsystem hierarchy	3-3

List of Tables

Table 1-1: Standard and optional accessories	1-2
Table 2-1: Signal set assigned to the test signal buttons	2-3
Table 2-2: Timing adjustment ranges for output signals	2-13
Table 2-3: Factory default settings	2-16
Table A-1: Output channels	A-1
Table A-2: Common output characteristics	A-1
Table A-3: Environmental characteristics	A-2

Preface

This manual documents the capabilities, operation, and specifications of the AWVG7 Analog Wideband Video Generator module.

About This Manual

This manual is composed of the following sections:

- *Getting Started* contains product description and functional check procedures.
- *Operating Basics* explains how to operate the AWVG7 module using the menus and front-panel buttons.
- *Reference* provides the syntax used in command descriptions and describes all programming commands.
- *Appendices* provides the specifications.

Related Manuals

The following documents are also available.

- The *TG700 TV Signal Generator Platform Service Manual* (Tektronix part number 070-A800-XX) describes how to maintain and service the mainframe and generator modules. This manual is an optional accessory.
- The *TG700 TV Signal Generator Platform Module Installation Instructions* (Tektronix part number 070-A824-XX) describes how to install and remove the modules, and how to upgrade the firmware of the mainframe.



Getting Started

Getting Started

This section contains the following information:

- Product description
- Accessories
- Option
- Installation
- Functional check

Product Description

The AWVG7 Analog Wideband Video Generator module is designed to be installed in the TG700 TV Signal Generator Platform. The TG700 platform must be running version 3.1 or later firmware.

The module is a 30 MHz bandwidth video signal generator which provides wideband analog component video signals for HDTV system. The module contains the following features:

- Supports the following system formats:
1080/60i, 1080/59.94i, 1080/50i, 1080/24sF, 1080/23.98sF, 1080/30p, 1080/29.97p, 1080/25p, 1080/24p, 1080/23.98p, 720/60p, 720/59.94p, 720/50p, 720/24p, and 720/23.98p
- Six analog component video outputs
- Outputs a frame picture created by the Frame Picture Generator application (TG700 Option FP required)
- Overlay of circle, text, or logo on the video signal
- Generates a moving picture by scrolling the active picture area of the output test signal
- Full remote control using Ethernet interface

The signals of the following system formats are pre-installed in the mainframe:

1080/60i, 1080/59.94i, 1080/24sF, 1080/23.98sF, 720/60p, 720/59.94p

The signals other than above are included in the supplied CD-ROM, and you can output the signals by downloading them to the mainframe. Refer to the *TG700 TV Signal Generator Platform User Manual* for detailed information on how to download a signal file.

Accessories

Table 1-1 lists the standard and optional accessories provided with the AWVG7 Generator module.

Table 1-1: Standard and optional accessories

Accessory	Std.	Opt.	Tektronix part number
TG700 TV Signal Generator Platform Module Installation Instructions	●		070-A824-XX
TG700 Signal Generator Platform Software Library CD-ROM	●		062-A249-XX
TG700 TV Signal Generator Platform Service Manual		●	070-A800-XX

Option

This subsection describes the option available for the AWVG7 Generator module. The following option is available:

Option D1 (Test data report)

Option D1 (Test Data Report)

A calibration test data report will be provided with the AWVG7 Generator module when this option is specified.

Installation

Refer to the *TG700 TV Signal Generator Platform Module Installation Instructions* for instructions on how to install the AWVG7 Generator module.

NOTE. *If the firmware version of your TG700 mainframe is 2.1 or earlier, you need to upgrade the firmware of the mainframe before using the AVG7 module. Refer to the TG700 TV Signal Generator Platform Module Installation Instructions for the procedures.*

Functional Check

The following procedure determines whether the module is operating correctly.

Required equipment

The following equipment is required for the functional check:

- HDTV waveform monitor
- Three 75 Ω BNC cables
- Three 75 Ω terminators

Procedure

1. Install the module into the TG700 Platform mainframe using the installation procedures described in the *TG700 TV Signal Generator Platform User Manual*.
2. Power on the TG700 TV Signal Generator Platform by connecting it to the power source. The initialization of all the installed modules is executed.
3. Check that no error messages appear on the LCD display.
4. Warm up the instrument for 20 minutes.
5. Press the front-panel **MODULE** button until the AWVG7 main menu shown below appears.

AWVG7 [x]: STATUS: 1080 59i YPbPr
100% Color Bars

6. Press the **FORMAT** button and use the left (◀) or right (▶) arrow button to select a format, then press the **ENTER** button.

7. Press one of the front-panel test signal buttons (for example **COLOR BAR**) to output a signal.
8. Use the 75 Ω BNC cables to connect the upper (or lower) **CH 1**, **CH 2**, and **CH 3** connectors to the **CH A**, **CH B**, and **CH C** inputs of the waveform monitor respectively.
9. Use the 75 Ω terminators to terminate the other loop through connectors on the waveform monitor rear panel.
10. Press the **CH A** button on the waveform monitor, and set the waveform monitor to view the signal.
11. Check that the signal appears as expected. For example, if you selected a color bar signal in step 7, check that the color bar signal appears.
12. Press the **CH B** button on the waveform monitor.
13. Check that the signal appears as expected. For example, if you selected a color bar signal in step 7, check that the color bar signal appears.
14. Press the **CH C** button on the waveform monitor.
15. Check that the signal appears as expected. For example, if you selected a color bar signal in step 7, check that the color bar signal appears.
16. Press the **CH A** button on the waveform monitor.
17. Press the test signal button again to output another test signal in the same signal set.
18. Check that the signal on the waveform monitor changes. You do not need to perform this check for the CH 2 and CH 3 connectors.
19. Disconnect the BNC cable from the upper (or lower) **CH 1**, **CH 2**, and **CH 3** connectors, and then connect the BNC cables to the lower (or upper) **CH 1**, **CH 2**, and **CH 3** connectors.
20. Repeat steps 10 through 18 for the lower (or upper) output channels.



Operating Basics

Operating Basics

This section explains the operation of the AWVG7 Generator module using the front-panel buttons and menus. It also contains descriptions of the rear-panel connectors.

Refer to the *TG700 TV Signal Generator Platform User Manual* for a detailed explanation of the front-panel buttons and the LCD display.

Operating Procedure

After the module is installed in the mainframe, and the mainframe is installed in the rack or other location where it will be used, access each function of the module with the following procedure:

1. Connect the power connector on the rear panel to the AC electric power source using the power cord.

Electric power is supplied to the mainframe.

2. Wait until the power up initialization process is complete, and check that no error messages appear on the display.
3. Following the initialization process the mainframe main menu appears, as shown below.



TG700: PRESET

4. Press the front-panel **MODULE** button until the AWVG7 module main menu appears, as shown below.

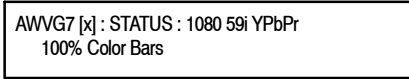

AWVG7 [x]: STATUS: 1080 59i YPbPr
100% Color Bars

5. Select the signal format and the signal you want to output. Refer to *Selecting an Output Signal* on page 2-2 for more information.
6. Press the front-panel arrow buttons to select the desired main menu item or submenu item.

Refer to *AWVG7 Module Main Menu* beginning on page 2-4 for detailed information about the main menu items and the submenu items.

Selecting an Output Signal

When you output a signal from the AWVG7 Generator module, you need to select a signal format and output signal. This subsection provides instructions on how to output a signal.

Selecting a Format

If you press the front-panel **FORMAT** button when the AWVG7 Generator module is selected (active), you can select the format for the output signals.

Perform the following steps to select the format:

1. Confirm that any menu item of the AWVG7 module main menu is displayed. If the menu is not displayed, press the front-panel **MODULE** button until the AWVG7 module main menu appears, as shown below.

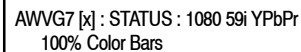

```
AWVG7 [x] : STATUS : 1080 59i YPbPr
100% Color Bars
```

2. Press the **FORMAT** button. The menu display changes as follows:

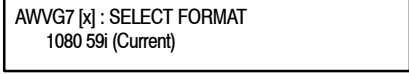

```
AWVG7 [x] : SELECT FORMAT
1080 59i (Current)
```

3. Press the left (◀) or right (▶) arrow button to select one of the signal formats, and then press the **ENTER** button to confirm the selection.

NOTE. When you change the signal format, synchronization shock occurs.

When you change the format while a signal is being output, the instrument starts loading all of the signal set for the format and displays the message “**Now Loading...**”. When you see the message, “**Done (Press CANCEL)**”, press the **CANCEL** button.

Selecting a Signal

All signal sets available in the module are already assigned to the corresponding test signal buttons (see Figure 2-1 on page 2-3). When you press any of the buttons, one of the signals in the signal set is output.

For example, when you press the **COLOR BAR** test signal button, you can output the **100% Color Bars** signal in the Color Bars signal set.

Press the left (◀) or right (▶) arrow button, or press the test signal button repeatedly to select different signals assigned to the test signal button.

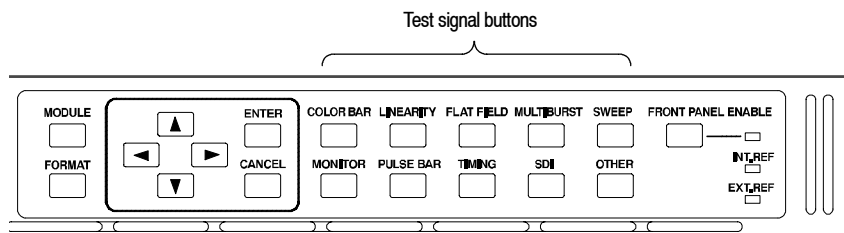

Figure 2-1: Front-panel test signal buttons

Table 2-1 lists the signal set assigned to each test signal button and the signals that can be selected in the signal set. The signals in the signal set can be added or changed with improvement of the module.

Table 2-1: Signal set assigned to the test signal buttons

Button name	Signal set	Signals in the signal set
COLOR BAR	Color Bars	100% Color Bars, 75% Color Bars
LINEARITY	Linearity	10 Step, 5 Step, Ramp, Shallow Ramp, Valid Ramp *
FLAT FIELD	Flat Fields	0% Flat Field, 100% Flat Field, 50% Flat Field
MULTI BURST	Multi Burst	Multiburst 1-10 MHz, Multiburst 10-20 MHz, Multiburst 20-30 MHz
SWEEP	Sweep	100% Sweep 1-15 MHz, 100% Sweep 1-30 MHz
MONITOR	Monitor	75% Blue Field, Convergence, 75% Green Field, 75% Red Field
PULSE BAR	Pulse & Bar	2T30 Pulse & Bar
TIMING	Timing	Bowtie 1 ns Marker
SDI	-----	-----
OTHER	-----	-----

* YPbPr format only

With the AWVG7, you can download a frame picture file created by Frame Picture Generator to the TG700 Option FP and output the picture. Refer to *TG700 TV Signal Generator Platform User Manual* for detailed information on how to create, download, and output a frame picture.

AWVG7 Module Main Menu

You can set the logo, circle, text overlay, and timing offset of the signal outputs by using the AWVG7 module main menu.

Use the up (▲) or down (▼) arrow button to scroll through the main menu. Figure 2-2 shows the AWVG7 module main menu.

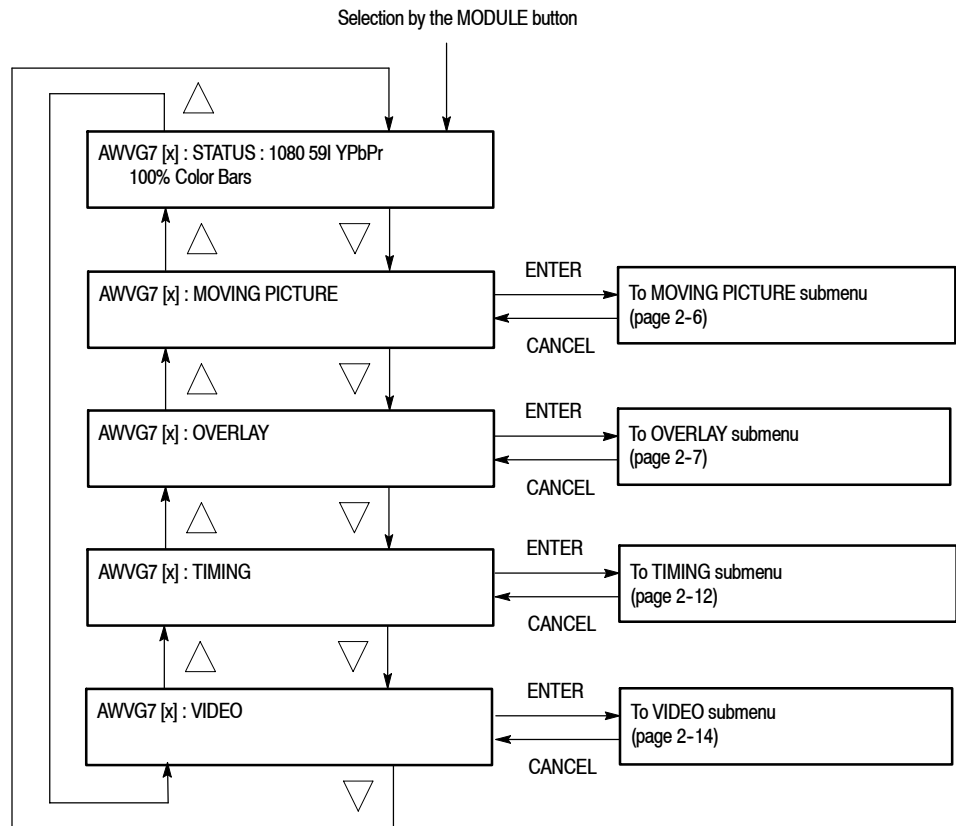

Figure 2-2: AWVG7 module main menu

MOVING PICTURE. Scrolls the active picture area of the output test signal. When you select this menu item and then press the ENTER button, you will access the MOVING PICTURE submenu. Refer to *MOVING PICTURE Submenu* on page 2-6 for detailed information.

OVERLAY. Selects an item (logo, text, or circle) that is overlaid on the output test signal and sets the blinking mode for the overlay. When you select this menu item and then press the ENTER button, you will access the OVERLAY submenu. Refer to *OVERLAY Submenu* on page 2-7 for detailed information.

TIMING. Sets the timing offset of the output signals relative to the internal reference signal (frame reset signal). When you select this menu item and then press the ENTER button, you will access the TIMING submenu. Refer to *TIMING Submenu* on page 2-12 for detailed information.

VIDEO. Sets whether or not a sync signal is multiplexed with the B and R signal when a GBR signal is being output and enables or disables the signal output from CH 1, CH 2, and CH 3. When you select this menu item and then press the ENTER button, you will access the VIDEO submenu. Refer to *VIDEO Submenu* on page 2-14 for detailed information.

**MOVING PICTURE
Submenu**

This menu allows you to scroll the active picture area of the output signal up/down or left/right (or randomly). Use the up (▲) or down (▼) arrow button to scroll the menu. Figure 2-3 shows the MOVING PICTURE submenu.

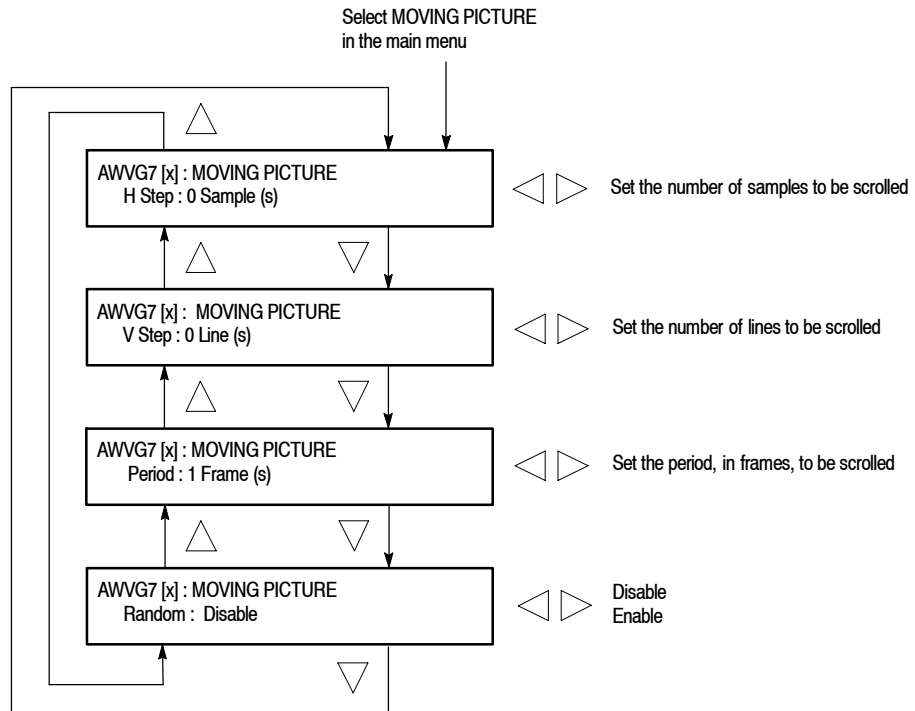

Figure 2-3: MOVING PICTURE submenu

- **H Step:** Sets the number of samples to be scrolled per frame set in the **Period** menu item. Use the left (◀) or right (▶) arrow button to change the value. You can set the value from -60 to +60 in 4 sampled steps.
- **V Step:** Sets the number of lines to be scrolled per frame set in the **Period** menu item. Use the left (◀) or right (▶) arrow button to change the value. You can set the value from -15 to +15 in 1 line step.
- **Period:** Sets the time interval between occurrences of the scrolling. Use the left (◀) or right (▶) arrow button to change the value. You can set the value from 1 to 16 in 1 frame step.
- **Random:** Sets whether or not the picture scrolls randomly. Use the left (◀) or right (▶) arrow button to select between **Disable** and **Enable**. Press the **ENTER** button to confirm the selection.

OVERLAY Submenu

This menu allows you to select an item (logo, ID Text, or circle) to overlay on the output test signal, and to set the blinking mode for the overlay. Use the up (▲) or down (▼) arrow button to scroll through the menu. Figure 2-4 shows the OVERLAY submenu.

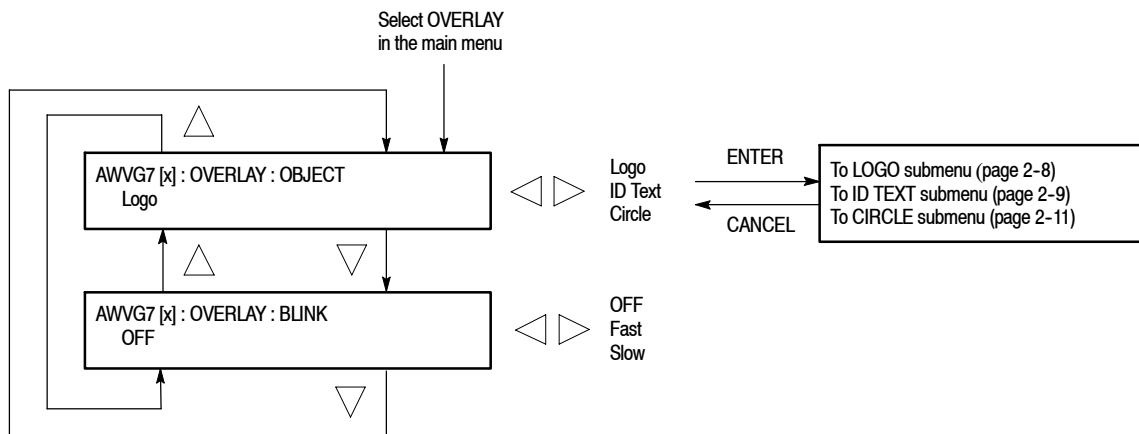

Figure 2-4: OVERLAY submenu

- **OBJECT:** Selects an item that is overlaid on the output test signal. Use the left (◀) or right (▶) arrow button to select **Logo**, **ID Text**, or **Circle**. When you select any of these items and then press the ENTER button, you will access the submenu for setting that overlay. Refer to *LOGO Submenu* on page 2-8, *ID TEXT Submenu* on page 2-9, or *CIRCLE Submenu* on page 2-11 for detailed information.
- **BLINK:** Sets the blinking mode for the overlay. Use the left (◀) or right (▶) arrow button to select **OFF**, **Fast** (blinks at approximately 0.5 second intervals), or **Slow** (blinks at approximately 1.0 intervals). Press the ENTER button to confirm the selection.

LOGO Submenu

This menu allows you to select a logo to overlay on the output test signal, and to set the display position of the logo. Use the up (▲) or down (▼) arrow button to scroll through the menu. Figure 2-5 shows the LOGO submenu.

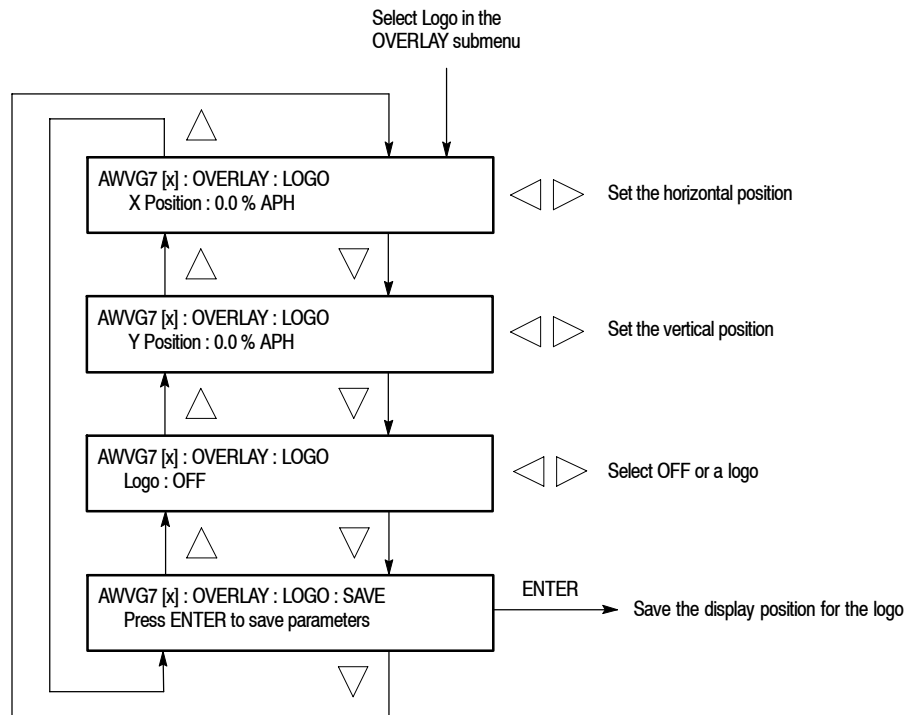

Figure 2-5: LOGO submenu

- **X Position:** Sets the horizontal position of the logo. The position is set as a percentage of active picture width. Use the left (◀) or right (▶) arrow button to change the position. You can set the value from -100.0% to 0.0% in 0.1% steps.
- **Y Position:** Sets the vertical position of the logo. The position is set as a percentage of active picture height. Use the left (◀) or right (▶) arrow button to change the position. You can set the value from -100.0% to 0.0% in 0.1% steps.
- **Logo:** Selects the logo you want to display. Use the left (◀) or right (▶) arrow button to select **OFF** or a logo file name. Press the **ENTER** button to confirm the selection. When you select **OFF**, the logo overlay is disabled.
- **SAVE:** Saves the display position for the logo to the logo file. Press the **ENTER** button to save the current settings.

In order to display a logo using the LOGO submenu, you need to create the logo file (.lgo) and download it to the LOGO folder of the module.

Refer to the *TG700 TV Signal Generator Platform User Manual* for detailed information about how to create a logo file and download it to the TG700.

ID TEXT Submenu

This menu allows you to edit text that is overlaid on the output test signal, and to set the display position of the text. Use the up (▲) or down (▼) arrow button to scroll through the menu. Figure 2-6 shows the ID TEXT submenu.

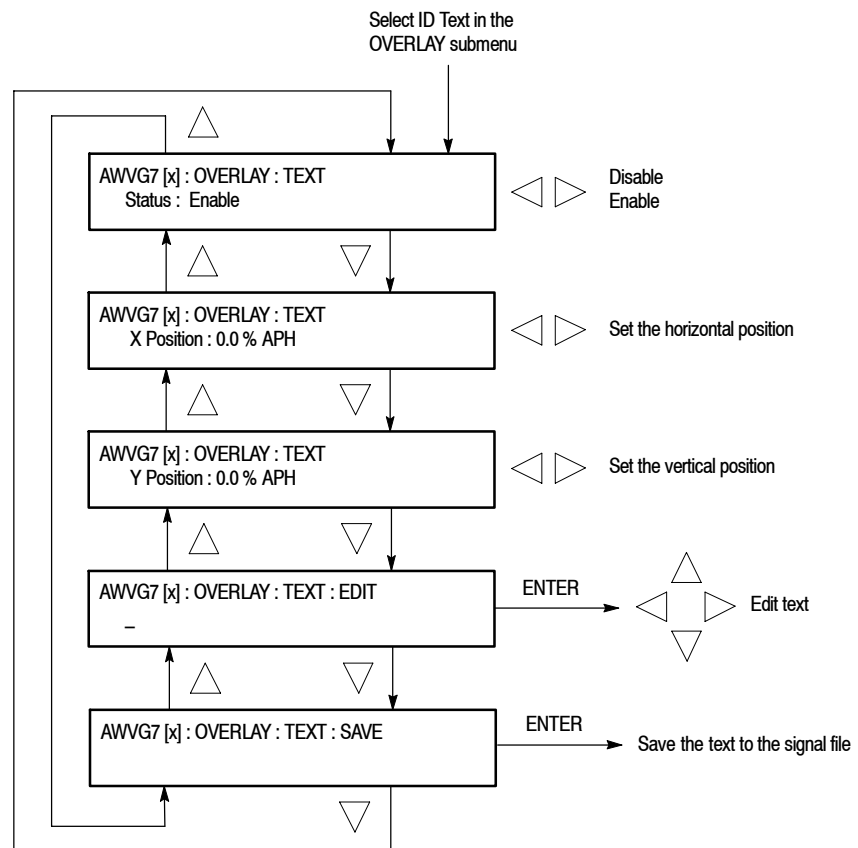

Figure 2-6: ID TEXT submenu

- **Status** : Enables or disables the text overlay. Use the left (◀) or right (▶) arrow button to select between **Enable** and **Disable**. Press the **ENTER** button to confirm the selection.
- **X Position**: Sets the horizontal position of the text. The position is set as a percentage of active picture width. Use the left (◀) or right (▶) arrow button to change the position. You can set the value from 0.0% to 100.0% in 1% steps.
- **Y Position**: Sets the vertical position of the text. The position is set as a percentage of active picture height. Use the left (◀) or right (▶) arrow button to change the position. You can set the value from 0.0% to 100.0% in 1% steps.
- **EDIT**: Edits the text you want to display on the output test signal.

To edit the text, first press the **ENTER** button to enable the text edit mode. Use the left (◀) or right (▶) arrow button to move the underscore character (_) to the character you want to change, and then use the up (▲) or down (▼) arrow button to select the desired character. When you enter all of the desired characters then press the **ENTER** button to end the text editing process. You can use up to 30 characters for the text. Use the blank character to erase any characters that are not needed.
- **SAVE**: Saves the text and its position to the signal file currently being output. Press the **ENTER** button to save the text and its position to the signal file.

CIRCLE Submenu

This menu allows you to create a circle overlaid on the output test signal and set its position on the display. Use the up (▲) or down (▼) arrow button to scroll through the menu. Figure 2-7 shows the CIRCLE submenu.

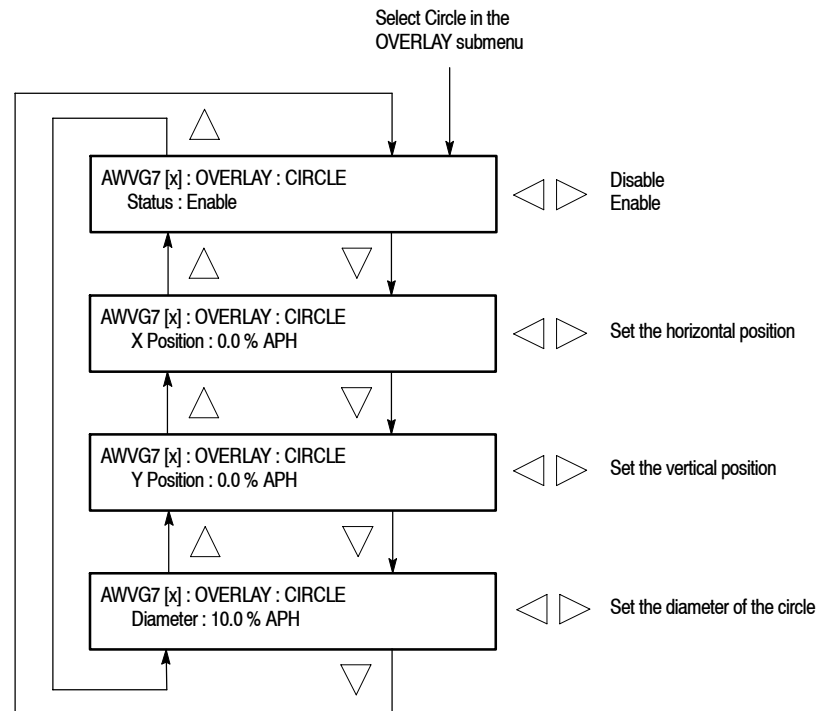

Figure 2-7: CIRCLE submenu

- **Status** : Enables or disables the circle overlay. Use the left (◀) or right (▶) arrow button to select between **Enable** and **Disable**. Press the **ENTER** button to confirm the selection.
- **X Position**: Sets the horizontal position of the circle. The position is set as a percentage of active picture width. Use the left (◀) or right (▶) arrow button to change the position. You can set the value from -50.0% to 50.0% in 1% steps.
- **Y Position**: Sets the vertical position of the circle. The position is set as a percentage of active picture height. Use the left (◀) or right (▶) arrow button to change the position. You can set the value from -50.0% to 50.0% in 1% steps.
- **Diameter**: Sets the diameter of the circle. The diameter is set as a percentage of active picture height. Use the left (◀) or right (▶) arrow button to change the value. You can set the value from 0.0% to 100.0% in 1% steps.

TIMING Submenu

This menu allows you to adjust the timing offset of the output signals relative to the internal reference signal (frame reset signal). Use the up (▲) or down (▼) arrow button to change the menu items. Figure 2-8 shows the TIMING submenu.

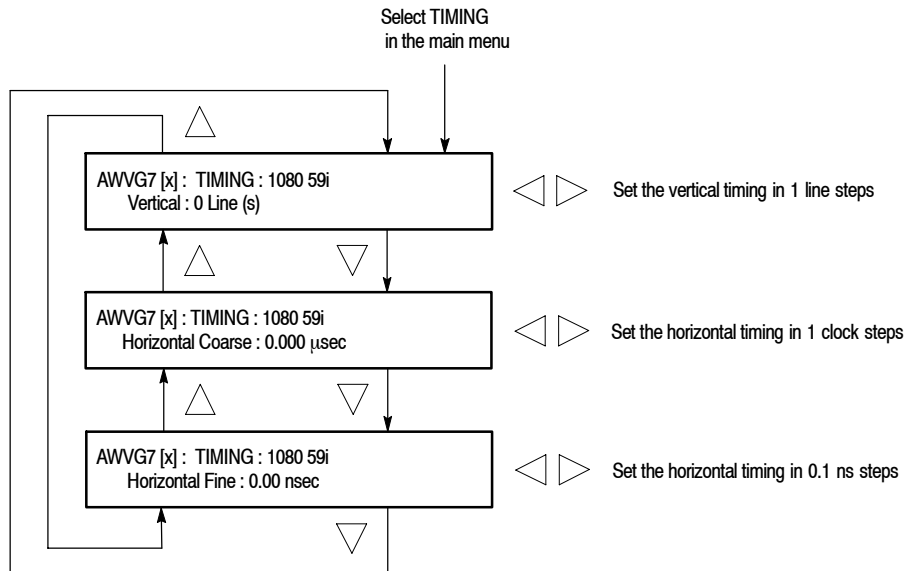

Figure 2- 8: TIMING submenu

- **Vertical:** Sets the vertical timing offset. Use the left (◀) or right (▶) arrow button to change the timing offset. You can set the value from -1 to +1 frame of the selected signal format in 1-line steps. Refer to Table 2-2 on page 2-13 for the appropriate range of each format.
- **Horizontal Coarse:** Use the left (◀) or right (▶) arrow button to adjust the coarse horizontal offset. You can set the value from -1 to +1 line of the selected signal format in 1-clock (18.5 ns) steps. Refer to Table 2-2 on page 2-13, for the appropriate range of each format.
- **Horizontal Fine:** Use the left (◀) or right (▶) arrow button to adjust the fine horizontal offset. You can set the value from -10 ns to +10 ns in 0.1 ns steps.

NOTE. You can reset the timing offset to zero by pressing the left (◀) and right (▶) arrow buttons simultaneously.

Table 2-2: Timing adjustment ranges for output signals

Format name	Line settings	Coarse settings (μs)	Fine settings (ns)
1080 60i YPbPr/GBR	± 562	± 29.6296	± 10.00
1080 59i YPbPr/GBR	± 562	± 29.6593	± 10.00
1080 50i YPbPr/GBR	± 562	± 35.5556	± 10.00
1080 24sF YPbPr/GBR	± 562	± 37.0370	± 10.00
1080 23sF YPbPr/GBR	± 562	± 37.0741	± 10.00
1080 30p YPbPr/GBR	± 562	± 29.6296	± 10.00
1080 29p YPbPr/GBR	± 562	± 29.6593	± 10.00
1080 25p YPbPr/GBR	± 562	± 35.5556	± 10.00
1080 24p YPbPr/GBR	± 562	± 37.0370	± 10.00
1080 23p YPbPr/GBR	± 562	± 37.0741	± 10.00
720 60p YPbPr/GBR	± 375	± 22.2222	± 10.00
720 59p YPbPr/GBR	± 375	± 22.4444	± 10.00
720 50p YPbPr/GBR	± 375	± 26.6667	± 10.00
720 30p YPbPr/GBR	± 375	± 53.3333	± 10.00
720 29p YPbPr/GBR	± 375	± 45.9770	± 10.00
720 25p YPbPr/GBR	± 375	± 44.4444	± 10.00
720 24p YPbPr/GBR	± 375	± 55.5556	± 10.00
720 23p YPbPr/GBR	± 375	± 55.6111	± 10.00

VIDEO Submenu

This menu allows you to enable or disable the signal output from CH 1, CH 2, and CH 3 connectors and to set whether or not a sync signal is multiplexed with the B and R signal when a GBR signal is being output. Use the up (▲) or down (▼) arrow button to scroll through the menu. Figure 2-9 shows the VIDEO submenu.

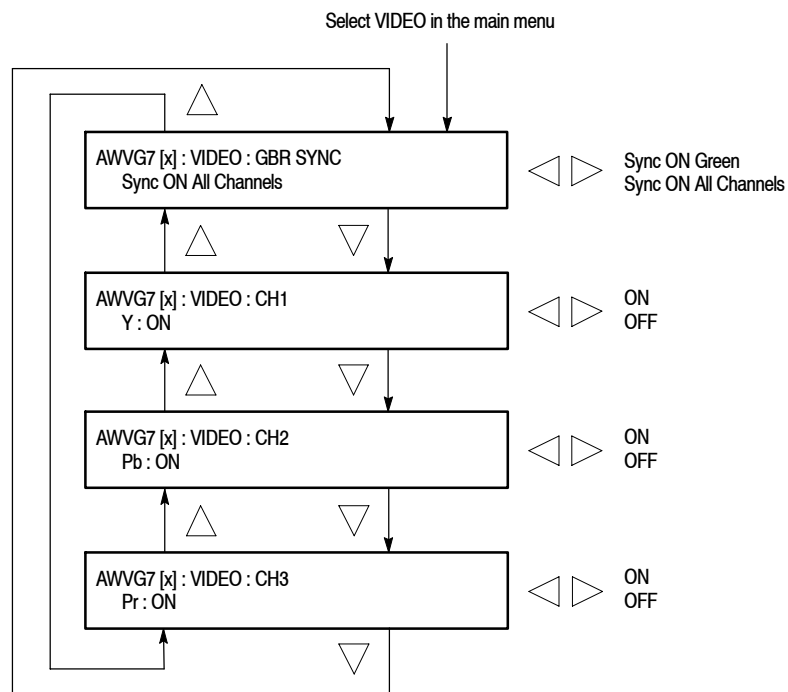

Figure 2-9: VIDEO submenu

- **GBR SYNC:** Sets whether or not a sync signal is multiplexed with the B signal and R signal when a GBR signal is being output. Use the left (◀) or right (▶) arrow button to select between **Sync ON Green** and **Sync ON All Channels**. When you select Sync ON All Channels, a sync signal is multiplexed with the G, B, and R signals. Press the **ENTER** button to confirm the selection. This menu item appears only when a GBR signal is being output.
- **CH 1:** Turns the CH 1 signal output on or off. Use the left (◀) or right (▶) arrow button to select between **ON** and **OFF**. Press the **ENTER** button to confirm the selection. The signal name displayed before the ON/OFF status depends on the video format of the currently selected signal (YPbPr component or GBR component).

- **CH 2:** Turns the CH 2 signal output on or off. Use the left (◀) or right (▶) arrow button to select between **ON** and **OFF**. Press the **ENTER** button to confirm the selection. The signal name displayed before the ON/OFF status depends on the video format of the currently selected signal (YPbPr component or GBR component).
- **CH 3:** Turns the CH 3 signal output on or off. Use the left (◀) or right (▶) arrow button to select between **ON** and **OFF**. Press the **ENTER** button to confirm the selection. The signal name displayed before the ON/OFF status depends on the video format of the currently selected signal (YPbPr component or GBR component).

Rear-Panel Connectors

The AWVG7 Generator module is equipped with six connectors: one pair of **CH 1**, **CH 2**, and **CH 3**, which will output analog component test signals. Figure 2-10 shows the AWVG7 Generator module rear-panel connectors.

NOTE. Each pair of connectors (CH 1, CH 2, and CH 3) will both output the same test signal.

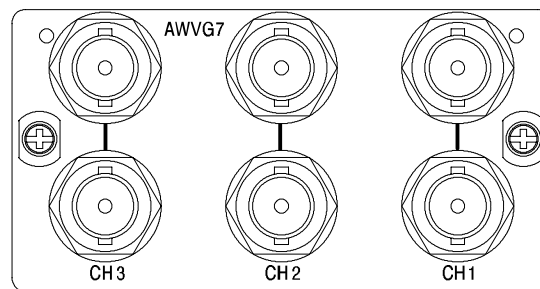

Figure 2-10: AWVG7 Generator module rear-panel connectors

- **CH 1:** Analog component test signal output.
- **CH 2:** Analog component test signal output.
- **CH 3:** Analog component test signal output.

Factory Default Settings

Table 2-3 shows the factory default settings for the AWVG7 Generator module. These settings are recalled when you select **Factory Default** from the **PRESET : RECALL** menu item in the mainframe main menu.

Table 2-3: Factory default settings

Menu item name	Settings
STATUS	1080 59i YPbPr 100% Color Bars
MOVING PICTURE	
H Step	0 Sample(s)
V Step	0 Line(s)
Period	1 Frame(s)
Random	Disable
OVERLAY : OBJECT	Logo
OVERLAY : BLINK	OFF
OVERLAY : LOGO	
Logo	OFF
OVERLAY : ID TEXT	
Status	Disable
OVERLAY : CIRCLE	
Status	Disable
X Position	0.0% APH
Y Position	0.0% APH
Diameter	90.0% APH
TIMING	
Vertical	0 Line(s)
Horizontal Coarse	0.000 μ s
Horizontal Fine	0.00 ns
VIDEO	
GBR SYNC	Sync ON All Channels
Y	ON
Pb	ON
Pr	ON



Reference

Syntax

This section contains information on the Standard Commands for Programmable Instruments (SCPI) and the programming structure you can use to program your AWVG7 Generator module.

Programming Model

Specific conditions must exist before programming commands will affect the test signal generated by a module.

Selecting the Module

Select the module using the :INSTRument:SElect command before executing any commands. Many of the commands used by the AWVG7 module are shared by several modules and will be accepted without a reported error.

Command Arguments

Many commands will accept either string or numeric arguments. For example: a boolean argument can either be “1” or “ON”.

Signal parameter commands that have a :STEP node can accept either a numeric value or they can accept a string argument that refers to the :STEP increment.

Signal parameter commands with a :STEP node will accept the following strings in addition to a numeric value:

UP. Use this argument to increase the parameter value one increment as defined by the :STEP value.

DOWN. Use this argument to decrease the parameter value one increment as defined by the :STEP value.

MINimum. Use this argument to set the parameter value to the minimum acceptable value.

MAXimum. Use this argument to set the parameter value to the maximum acceptable value.

DEFault. Use this argument to set the parameter value to the default value.

Query Arguments

If you send a query with no argument, the response is the current value. You can also use **MINimum**, **MAXimum**, and **DEFault** as arguments for queries whose command form can use these arguments (refer to the command syntax for the specific command). Instead of returning the current value, queries using these arguments return the following information:

MINimum. Return the minimum acceptable value.

MAXimum. Return the maximum acceptable value.

DEFault. Return the default value.

Argument Example

The following example demonstrates the effect of each of the arguments when used with a step value.

1. `:INSTRument:SElect "AWVG7:#"` selects the AWVG7 Generator module located in the slot number indicated by the “#” symbol.
2. `:OUTPut:CIRClE:STATe ON` displays a circle on the video display.

NOTE. `:OUTPut:CIRClE:DIAMeter` uses an argument that is the percent of picture height.

3. `:OUTPut:CIRClE:DIAMeter DEFaul t` sets the circle diameter to 90 percent of the screen height.
4. `:OUTPut:CIRClE:DIAMeter:STEP 10` sets the step increment to 10 percent.
5. `:OUTPut:CIRClE:DIAMeter DOWN` changes the circle diameter to 80 percent of the screen height.
6. `:OUTPut:CIRClE:DIAMeter 50` changes the circle diameter to 50 percent of the screen height.
7. `:OUTPut:CIRClE:DIAMeter MAXimum` changes the circle diameter to 100 percent of the screen height.
8. `:OUTPut:CIRClE:DIAMeter MINimum` changes the circle diameter to 0 percent of the screen height.
9. `:OUTPut:CIRClE:DIAMeter UP` changes the circle diameter to 10 percent of the screen height.
10. `:OUTPut:CIRClE:DIAMeter? MAXimum` queries the maximum circle diameter (not the current diameter). The query returns the value of 100 percent, which is the maximum circle diameter allowable.

SCPI Commands and Queries

SCPI is a standard created by a consortium that provides guidelines for remote programming of instruments. These guidelines provide a consistent programming environment for instrument control and data transfer. This environment uses defined programming messages, instrument responses, and data format across all SCPI instruments, regardless of manufacturer. The AWVG7 Generator module uses a command language based on the SCPI standard.

The SCPI language is based on a hierarchical or tree structure (see Figure 3-1) that represents a subsystem. The top level of the tree is the root node; it is followed by one or more lower-level nodes.

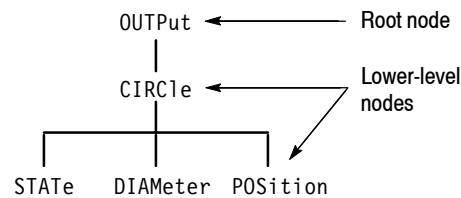

Figure 3-1: Example of SCPI subsystem hierarchy

You can create commands and queries from these subsystem hierarchy trees. Commands specify actions for the instrument to perform. Queries return measurement data and information about parameter settings.

For more information on SCPI commands and programming structure, refer to the *TG700 Signal Generator Platform User Manual*.

Remote Commands

This section describes the remote commands used to control the AWVG7 Generator module remotely. The commands to the module are divided into the following three groups:

- MASS MEMORY commands (Refer to the *TG700 TV Signal Generator Platform User Manual*)
- OUTPUT commands
- SENSE commands

MASS MEMORY Commands

Two MASS MEMORY commands are listed here for your reference. You can use these to load and query the output test signal. Detailed information for using these commands are located in the *TG700 TV Signal Generator Platform User Manual*.

```
:MMEMory:LOAD:SIGNa1 <module_name>,<signal_name>  
:MMEMory:LOAD:SIGNa1 <slot_number>,<signal_name>
```

Loads a signal into the specified module.

```
:MMEMory:SIGNa1:ACTive? <slot_number>|<module_name>
```

Returns the current output signal of the specified module.

OUTPUT Commands

Use these commands to control the output parameters of the module. These include output status and circle/text/logo overlay.

Command Tree

```
:OUTPut<n>
  :STATe          ON|OFF
  :CIRClE
    :STATe        ON|OFF
    :DIAMeter     <numeric_value>
    :POSition
      :HORizontal <numeric_value>
      :VERTical   <numeric_value>
  :LOGO
    :STATe        ON|OFF
    :POSition
      :HORizontal <numeric_value>
      :VERTical   <numeric_value>
    :SElect       <logo_name>
    :SAVe
  :TEXT
    :STATe        ON|OFF
    :DATA         <string>
    :POSition
      :HORizontal <numeric_value>
      :VERTical   <numeric_value>
    :SAVe
  :OVERlay
    :BLINK
      :STATe      ON|OFF
      :PERiod     <numeric_value>
  :MOVE
    :HORizontal   <numeric_value>
    :VERTical     <numeric_value>
    :PERiod       <numeric_value>
    :RANDom[:STATe] ON|OFF
  :VIDeo
    :SYNC
      :STATe      ON|OFF
```

Command Description

`:OUTPut<n>:STATe ON|OFF`

Turns the signal output of the specified channel on or off. The <n> in the command represents the output channel and you can specify 1, 2, or 3. You can use 1 or 0 instead of ON or OFF.

`:OUTPut<n>:STATe?`

Returns the current output state of the specified channel. The <n> in the command represents the output channel and you can specify 1, 2, or 3.

`:OUTPut1:CIRClE:STATe ON|OFF`

Turns the circle overlay on the video signal on or off. You can use 1 or 0 instead of ON or OFF.

`:OUTPut1:CIRClE:STATe?`

Returns the current circle overlay state.

`:OUTPut1:CIRClE:DIAMeter <numeric_value>`

Sets the diameter of the displayed circle. The unit is the percent of active picture height. You can set the diameter from 0% to 100% in 1% steps. You can also use MIN, MAX, or DEF instead of a numeric value.

`:OUTPut1:CIRClE:DIAMeter?`

Returns the diameter of the displayed circle.

`:OUTPut1:CIRClE:POSition:HORizontal <numeric_value>`

Sets the horizontal position of the circle as it appears on the active signal. The unit is the percent of active picture width. You can set the position from -50% to +50% in 1% steps. You can also use MIN, MAX, or DEF instead of a numeric value.

`:OUTPut1:CIRClE:POSition:HORizontal?`

Returns the current horizontal position of the circle as it appears on the active signal.

`:OUTPut1:CIRClE:POSition:VERTical <numeric_value>`

Sets the vertical position of the circle as it appears on the active signal. The unit is the percent of active picture height. You can set the position from -50% to +50% in 1% steps. You can also use MIN, MAX, or DEF instead of a numeric value.

:OUTPut1:CIRClE:POSition:VERTical?

Returns the current vertical position of the circle as it appears on the active signal.

:OUTPut1:LOGO:STATe ON|OFF

Turns the logo overlay on the video signal on or off. You can use 1 or 0 instead of ON or OFF.

:OUTPut1:LOGO:STATe?

Returns the current logo overlay state.

:OUTPut1:LOGO:POSition:HORizontal <numeric_value>

Sets the horizontal position of the logo as it appears on the active signal. The unit is the percent of active picture width. You can set the position from -100% to 0% in 0.1% steps. You can also use MIN, MAX, or DEF instead of a numeric value.

:OUTPut1:LOGO:POSition:HORizontal?

Returns the current horizontal position of the logo.

:OUTPut1:LOGO:POSition:VERTical <numeric_value>

Sets the vertical position of the logo as it appears on the active signal. The unit is the percent of active picture height. You can set the position from -100% to 0% in 0.1% steps. You can also use MIN, MAX, or DEF instead of a numeric value.

:OUTPut1:LOGO:POSition:VERTical?

Returns the current vertical position of the logo.

:OUTPut1:LOGO:SElect <logo_name>

Selects the logo used for the logo overlay.

:OUTPut1:LOGO:SElect?

Returns the current logo used for the logo overlay.

:OUTPut1:LOGO:SAVe

Saves the current display position of the logo to the logo file. There are no arguments.

:OUTPut1:TEXT:STATe ON|OFF

Turns the text overlay on the video signal on or off. You can use 1 or 0 instead of ON or OFF.

:OUTPut1:TEXT:STATE?

Returns the current text overlay state.

:OUTPut1:TEXT:DATA <string>

Sets the current string for the text mode.

:OUTPut1:TEXT:DATA?

Returns the current string for the text mode.

:OUTPut1:TEXT:POSition:HORizontal <numeric_value>

Sets the text horizontal position in the video signal. The unit is the percent of active picture width. You can set the position from 0% to 100% in 1% steps. You can also use MIN, MAX, or DEF instead of the numeric value.

:OUTPut1:TEXT:POSition:HORizontal?

Returns the current text horizontal position in the video signal.

:OUTPut1:TEXT:POSition:VERTical <numeric_value>

Sets the text vertical position in the video signal. The unit is the percent of active picture height. You can set the position from 0% to 100% in 1% steps. You can also use MIN, MAX, or DEF instead of the numeric value.

:OUTPut1:TEXT:POSition:VERTical?

Returns the current text vertical position in the video signal.

:OUTPut1:TEXT:SAVe

Saves the current text and its display position to the signal file. There are no arguments.

:OUTPut1:OVERlay:BLINK:STATE ON|OFF

Turns on or off the blinking mode for the logo, text, and circle overlay. You can also use 1 or 0 instead of ON or OFF.

:OUTPut1:OVERlay:BLINK:STATE?

Returns the current state of the blinking mode for the logo, text, and circle overlay.

:OUTPut1:OVERlay:BLINK:PERiod <numeric_value>

Sets the blinking interval of the blinking mode for the logo, text, and circle overlay. You can set the value as 0.5 seconds or 1.0 seconds.

:OUTPut1:OVERlay:BLINK:PERiod?

Returns the blinking interval of the blinking mode for the logo, text, and circle overlay.

:OUTPut1:MOVE:HORizontal <numeric_value>

Sets the amount of horizontal scrolling in the moving picture mode. You can set the value from -252 to +252 in 4 samples steps.

:OUTPut1:MOVE:HORizontal?

Returns the amount of horizontal scrolling in the moving picture mode.

:OUTPut1:MOVE:VERTical <numeric_value>

Sets the amount of vertical scrolling in the moving picture mode. You can set the value from -252 to +252 in 1 line steps.

:OUTPut1:MOVE:VERTical?

Returns the amount of vertical scrolling in the moving picture mode.

:OUTPut1:MOVE:PERiod <numeric_value>

Sets the time interval between occurrences of the scrolling. You can set the value from 1 to 16 in 1 field steps.

:OUTPut1:MOVE:PERiod?

Returns the time interval between occurrences of the scrolling.

:OUTPut1:MOVE:RANDom:STATe ON|OFF

Turns the random scrolling mode on or off. You can also use 1 or 0 instead of ON or OFF.

:OUTPut1:MOVE:RANDom:STATe?

Returns the current state of the random scrolling mode.

:OUTPut1:VIDeo:SYNC:STATe ON|OFF

Sets whether or not a sync signal is multiplexed with the B and R signals when a GBR signal is being output. You can also use 1 or 0 instead of ON or OFF.

:OUTPut1:VIDeo:SYNC:STATe?

Returns whether or not a sync signal is multiplexed with the B and R signals when a GBR signal is being output.

SENSE Commands

Use these commands to set the timing offset of the output signals relative to the internal reference signal (frame reset signal).

Refer to *Operating Basics* for detailed information about the setting range.

Command Tree

```
:SENSe<n>
  :CORRection
    :MDElay
      :HORizontal <numeric_value>
        :STEP <numeric_value>
      :VERTical <numeric_value>
        :STEP <numeric_value>
```

Command Description

```
:SENSe1:CORRection:MDElay:HORizontal <numeric_value>
```

Sets the horizontal timing offset of the output signals. The timing resolution is clock-cycles. The units are microseconds. You can use UP, DOWN, or DEF instead of the numeric value. If the argument exceeds the horizontal time value, then the vertical offset is adjusted to accommodate the requested delay.

```
:SENSe1:CORRection:MDElay:HORizontal?
```

Returns the current horizontal timing offset of the output signals.

```
:SENSe1:CORRection:MDElay:HORizontal:STEP <numeric_value>
```

Sets the step increment used by the UP or DOWN commands. The units are microseconds. You can use MIN, MAX, or DEF instead of a numeric value.

```
:SENSe1:CORRection:MDElay:HORizontal:STEP?
```

Returns the current step increment.

```
:SENSe1:CORRection:MDElay:VERTical <numeric_value>
```

Sets the vertical timing offset of the output signals. The argument can be a floating point value that is translated into integer lines with a horizontal offset. You can use UP, DOWN, or DEF instead of a numeric value.

`:SENSe1:CORRection:MDELay:VERTical?`

Returns the current vertical timing offset of the output signals.

`:SENSe1:CORRection:MDELay:VERTical:STEP <numeric_value>`

Sets the step increment used by the UP or DOWN commands. You can use MIN, MAX, or DEF instead of a numeric value.

`:SENSe1:CORRection:MDELay:VERTical:STEP?`

Returns the current step increment.



Appendices

Appendix A: Specifications

Tables A-1 through A-3 list the electrical and environmental characteristics of the AWVG7 Generator module.

Electrical Characteristics

Table A- 1: Output channels

Characteristic	Performance requirements	Reference information
Channel 1 (CH 1)		
Number of outputs	2	
Output signals	Y or G	
Channel 2 (CH 2)		
Number of outputs	2	
Output signals	Pb or B	
Channel 3 (CH 3)		
Number of outputs	2	
Output signals	Pr or R	

Table A- 2: Common output characteristics

Characteristic	Performance requirements	Reference information
Amplitude error		
Absolute amplitude	$\leq 1\%$	Measured at 700 mV.
Channel gain matching	$\leq 0.5\%$	Measured at 700 mV, relative to CH 1.
Delay error		
Channel to channel delay, typical		≤ 1 ns; relative to CH 1
Group delay, typical		≤ 3 ns to 20 MHz ≤ 5 ns to 30 MHz
Frequency response	$\pm 1\%$ to 20 MHz $\pm 2\%$ to 28 MHz $\pm 3\%$ to 30 MHz	Measured with a 1 m coax cable and peak detector.
Line tilt	$\leq 0.5\%$	Measured with 100% Flat Field test signal.
Field tilt	$\leq 0.5\%$	Measured with 100% Flat Field test signal.

Table A-2: Common output characteristics (cont.)

Characteristic	Performance requirements	Reference information
Pulse/bar ratio		1:1 within 0.5% with 2T5 pulse and bar signal.
DC offset	≤ 10 mV	
Return loss	≥ 35 dB to 30 MHz	

Environmental Characteristics

Table A-3: Environmental characteristics

Characteristic	Description
Temperature	
Operating	0 °C to +50 °C
Non-operating	-20 °C to +60 °C
Relative Humidity	
Operating	20% to 80% (No condensation); Maximum wet-bulb temperature 29.4 °C
Non-operating	5% to 90% (No condensation); Maximum wet-bulb temperature 40.0 °C
Altitude	
Operating	To 4.5 km (15 000 feet) Maximum operating temperature decreases 1 °C each 300 m above 1.5 km.
Non-operating	To 15 km (50 000 feet)
Vibration	
Operating	2.65 m/s ² (0.27 G _{rms}), 5 Hz to 500 Hz, 10 min, three axes
Non-operating	22.36 m/s ² (2.28 G _{rms}), 5 Hz to 500 Hz, 10 min, three axes
Shock	
Non-operating	588 m/s ² (60 G), half-sine, 11 ms duration



Index

Index

A

- Accessories
 - optional, 1-2
 - standard, 1-2
- AWVG7 features, 1-1
- AWVG7 module main menu, 2-4
 - MOVING PICTURE, 2-5
 - OVERLAY, 2-5
 - TIMING, 2-5
 - VIDEO, 2-5

C

- CH 1 connector, 2-15
- CH 2 connector, 2-15
- CH 3 connector, 2-15
- Circle overlay, 2-11
- CIRCLE submenu, 2-11
- Commands
 - Rules for forming, 3-1
 - Syntax, 3-1

E

- Electrical specifications, A-1
- Environmental specifications, A-2

F

- Factory default settings, 2-16
- Functional check, 1-3

H

- Hierarchy (SCPI), 3-3

I

- ID TEXT submenu, 2-9
- Installation, 1-3

L

- Logo overlay, 2-8
- LOGO submenu, 2-8

M

- Manuals, Related, iii
- MASS MEMORY commands, 3-5
- MOVING PICTURE submenu, 2-6

O

- Operating procedure, 2-1
- Option, 1-2
- Optional accessories, 1-2
- OUTPUT commands, 3-6
- OVERLAY submenu, 2-7

P

- Product description, 1-1

R

- Rear-panel connectors, 2-15
- Related Manuals, iii
- Remote commands, 3-5
- Rules, Command forming, 3-1

S

- SCPI, Subsystem hierarchy tree, 3-3
- SCPI commands and queries syntax, 3-3
- SENSE Commands, 3-11
- Signal set assigned to the test signal buttons, 2-3
- Specifications
 - Electrical, A-1
 - Environmental, A-2
- Standard accessories, 1-2
- Syntax, Command, 3-1

T

- Text overlay, 2-9
- TIMING submenu, 2-12

V

- VIDEO submenu, 2-14

User Manual



BG7 Black Generator

Copyright © Tektronix. All rights reserved. Licensed software products are owned by Tektronix or its suppliers and are protected by United States copyright laws and international treaty provisions.

Tektronix products are covered by U.S. and foreign patents, issued and pending. Information in this publication supercedes that in all previously published material. Specifications and price change privileges reserved.

TEKTRONIX and TEK are registered trademarks of Tektronix, Inc.

Contacting Tektronix

Tektronix, Inc.
14200 SW Karl Braun Drive
P.O. Box 500
Beaverton, OR 97077
USA

For product information, sales, service, and technical support:

- In North America, call 1-800-833-9200.
- Worldwide, visit www.tektronix.com to find contacts in your area.

Table of Contents

Preface	iii
About This Manual	iii
Related Manuals	iii
Getting Started	
Product Description	1-1
Accessories	1-1
Options	1-2
Installation	1-2
Functional Check	1-2
Operating Basics	
Operating Procedure	2-1
BG7 Module Main Menu	2-2
Rear-Panel Connectors	2-5
Factory Default Settings	2-6
Reference	
Syntax	3-1
Programming Model	3-1
SCPI Commands and Queries	3-3
Remote Commands	3-5
OUTPUT Commands	3-5
SENSE Commands	3-7
Appendices	
Appendix A: Specifications	A-1
Electrical Characteristics	A-1
Environmental Characteristics	A-2
Index	

List of Figures

Figure 2-1: BG7 module main menu	2-2
Figure 2-2: SELECT FORMAT submenu	2-2
Figure 2-3: SELECT SIGNAL submenu	2-3
Figure 2-4: TIMING submenu	2-4
Figure 2-5: BG7 module rear-panel connectors	2-5
Figure 3-1: Example of SCPI subsystem hierarchy	3-3

List of Tables

Table 1-1: Standard and optional accessories	1-1
Table 2-1: Selectable signals for each video format	2-4
Table 2-2: Factory default settings	2-6
Table A-1: Black burst and HDTV trilevel sync outputs	A-1
Table A-2: Color bars and black burst with field ID outputs (option CB)	A-2
Table A-3: Environmental characteristics	A-2

Preface

This manual documents the capabilities, operation, and specifications of the BG7 Black Generator module.

About This Manual

This manual is composed of the following sections:

- *Getting Started* contains product description and functional check procedure.
- *Operating Basics* explains how to operate the BG7 module using the menus and front-panel buttons.
- *Reference* provides the syntax used in command descriptions and describes all programming commands.
- *Appendices* provides the specifications.

Related Manuals

The following documents are also available.

- The *TG700 TV Signal Generator Platform Service Manual* (Tektronix part number 070-A800-XX) describes how to maintain and service the mainframe and generator modules. This manual is an optional accessory.
- The *TG700 TV Signal Generator Platform Module Installation Instructions* (Tektronix part number 070-A824-XX) describes how to install and remove the modules, and how to upgrade the firmware of the mainframe.



Getting Started

Getting Started

This section contains the following information:

- Product description
- Accessories
- Options
- Installation
- Functional check

Product Description

The BG7 Black Generator module is designed to be installed in the TG700 TV Signal Generator Platform.

The module is a multi format black generator with the following features:

- Four NTSC (with or without setup) /PAL black burst and HDTV trilevel sync outputs
- Individual format and timing control for each output
- Black burst with field ID and NTSC/PAL color bars signals output (Option CB)
- Full remote control using Ethernet interface

Accessories

Table 1-1 lists the standard and optional accessories provided with the BG7 Generator module.

Table 1-1: Standard and optional accessories

Accessory	Std.	Opt.	Tektronix part number
TG700 TV Signal Generator Platform Module Installation Instructions	●		070-A824-XX
TG700 Signal Generator Platform Software Library CD-ROM	●		062-A249-XX
TG700 TV Signal Generator Platform Service Manual		●	070-A800-XX

Options

This subsection describes the options available for the BG7 Generator module. The following options are available:

Option CB (NTSC/PAL Color Bars)

Option D1 (Test data report)

Option CB (NTSC/PAL Color Bars)

Option CB adds 10 field ID and NTSC/PAL color bar signals to the standard black burst signal. These additional signals are available from the BLACK 3 and BLACK 4 outputs only.

Option D1 (Test Data Report)

A calibration test data report will be provided with the BG7 Generator module when this option is specified.

Installation

Refer to the *TG700 TV Signal Generator Platform Module Installation Instructions* for instructions on how to install the BG7 Generator module.

Functional Check

The following procedure determines whether the module is operating correctly.

Required equipment

The following equipment is required for the functional check:

- NTSC/PAL waveform monitor
- HDTV waveform monitor
- 75 Ω BNC cable

Procedure

1. Install the module into the TG700 Platform mainframe using the installation procedures described in the *TG700 TV Signal Generator Platform User Manual*.
2. Power on the TG700 TV Signal Generator Platform. The initializing process for all installed modules is executed.
3. Check that no error messages appear on the LCD display.
4. Warm up the instrument for 20 minutes.

5. Press the front-panel **MODULE** button until the BG7 main menu shown below appears.

BG7 [x] : SELECT OUTPUT
BLACK 1

6. Press the front-panel **ENTER** button. The SELECT FORMAT submenu shown below appears.

BG7 [x] : BLACK 1 : SELECT FORMAT
NTSC

7. Press the left (◀) or right (▶) arrow button to select **NTSC** or **PAL**.
8. Press the **ENTER** button. The SELECT SIGNAL submenu shown below appears.

BG7 [x] : BLACK 1 : SELECT SIGNAL
Black Burst

9. Press the left (◀) or right (▶) arrow button to select **Black Burst** and then press the **ENTER** button to enable the selection.
10. Connect the **BLACK 1** connector to the NTSC/PAL waveform monitor using the 75 Ω BNC cable.
11. Set the waveform monitor to view the blanking area of the signal.
12. Check that the appropriate black burst signal is displayed.
13. Press the front-panel **CANCEL** button to return to the SELECT FORMAT submenu shown in step 6.
14. Press the left (◀) or right (▶) arrow button to select **HD SYNC**.
15. Press the **ENTER** button. The SELECT SIGNAL submenu shown in step 8 appears to select the HDTV trilevel sync signal.
16. Press the left (◀) or right (▶) arrow button to select **1080 59.94i** and then press the **ENTER** button to enable the selection.
17. Disconnect the BNC cable from the NTSC/PAL waveform monitor, and then reconnect it to the HDTV waveform monitor.
18. Check that the appropriate HDTV trilevel sync signal is displayed.

19. Repeat this procedure for the **BLACK 2**, **BLACK 3**, and **BLACK 4** outputs.



Operating Basics

Operating Basics

This section explains the operation of the BG7 Generator module using the front-panel buttons and menu. There is also a description of the rear-panel output connectors.

Refer to the *TG700 TV Signal Generator Platform User Manual* for a detailed explanation of the front-panel buttons and LCD display.

Operating Procedure

After the module is installed in the mainframe, and the mainframe is installed in the rack or other location where it will be used, access each function of the module with the following procedure:

1. Connect the power connector on the rear panel and AC electric power source using the power cord.

Electric power is supplied to the mainframe.

2. Wait until the power up initialization process is complete, and check that there are no error messages on the display.
3. Following the initialization process the mainframe main menu appears, as shown below.



TG700 : PRESET

4. Press the front-panel **MODULE** button until the BG7 module main menu shown below appears.

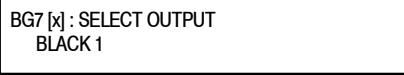

BG7 [x] : SELECT OUTPUT
BLACK 1

5. Use the front-panel arrow buttons to navigate and select items in the main menu and submenu.

The details of the main menu and submenu are explained on the following pages.

BG7 Module Main Menu

In the BG7 module main menu, there is one menu item to select the output whose parameters are to be changed. Figure 2-1 shows the BG7 module main menu.

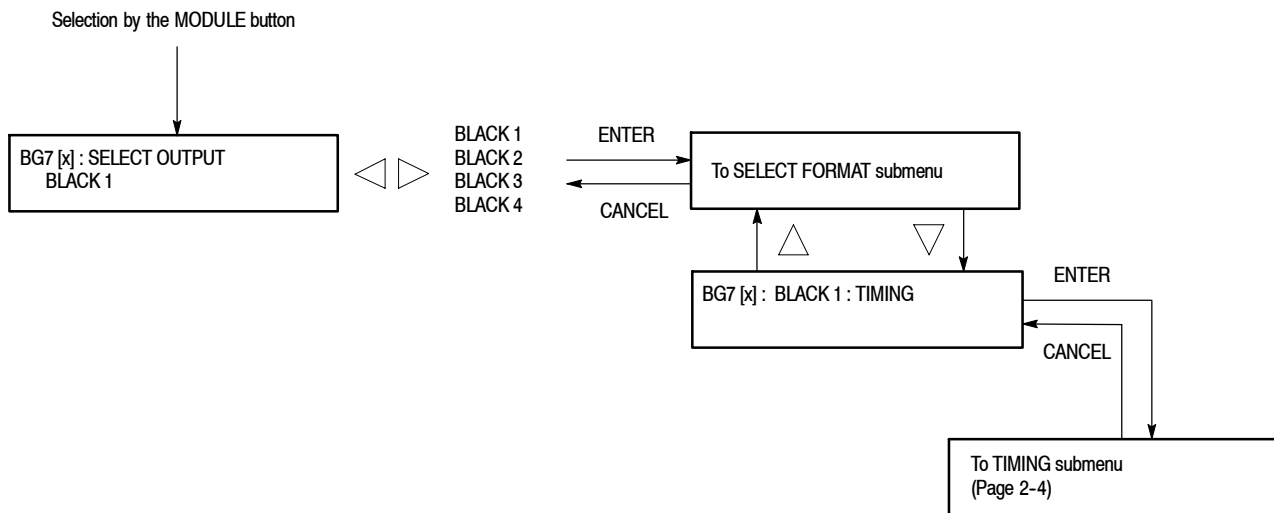

Figure 2- 1: BG7 module main menu

SELECT OUTPUT. Selects the output whose parameters are to be set. Use the left (◀) or right (▶) arrow button to make the selection. The choices are **BLACK 1**, **BLACK 2**, **BLACK 3**, and **BLACK 4**.

You can access the **SELECT FORMAT** submenu to set the format of the selected output by pressing the front-panel ENTER button. Refer to the *SELECT FORMAT Submenu* on this page for detailed information about the **SELECT OUTPUT** submenu.

SELECT FORMAT Submenu

This menu allows you to set the video format for the selected output. Figure 2-2 shows the **SELECT FORMAT** Submenu.

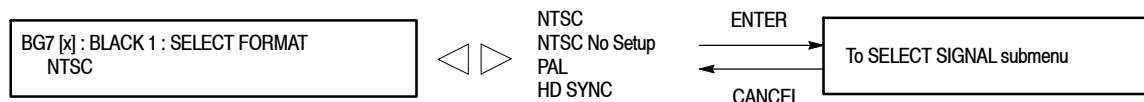

Figure 2- 2: SELECT FORMAT submenu

NOTE. When you change the video format, synchronization shock will occur.

Use the left (◀) or right (▶) arrow button to make the selection. The choices are **NTSC**, **NTSC No Setup**, **PAL**, and **HD SYNC**. For **HD SYNC**, you can output a HDTV trilevel sync signal.

You can access the **SELECT SIGNAL** submenu to select the kind of output signal by pressing the front-panel **ENTER** button. Refer to the *SELECT SIGNAL Submenu* on this page for detailed information about the **SELECT SIGNAL** submenu.

When you press the up (▲) or down (▼) arrow button while the **SELECT FORMAT** menu item is displayed, you enter the **TIMING** menu. If you select the menu item and press the **ENTER** button, you then access the **TIMING** submenu to set the timing offset for the selected black signal output. Refer to the *TIMING Submenu* on page 2-4 for detailed information about the **TIMING** submenu.

SELECT SIGNAL Submenu

This menu allows you to select black signal output from the selected **BLACK** output. Figure 2-3 shows the **SELECT SIGNAL** submenu.

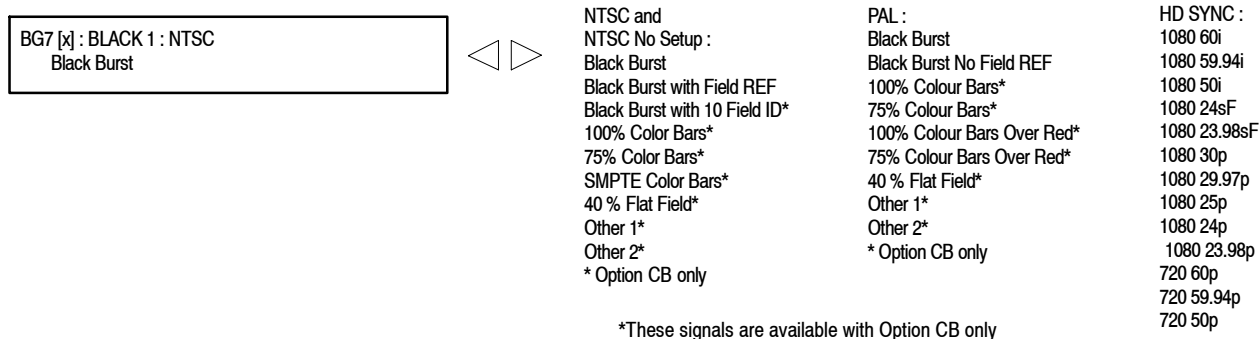

Figure 2-3: SELECT SIGNAL submenu

Use the left (◀) or right (▶) arrow button to scroll through the selections. Pressing the **ENTER** button enables the selected item.

Signals for selection depend on the video format selected in the **SELECT FORMAT** submenu.

For **NTSC**, **NTSC No Setup**, and **PAL**, you can select the black burst signal or the color bars signal (Option CB). For **HD SYNC**, you can select the HDTV trilevel sync signal.

Table 2-1 lists the selectable signals for each video format.

Table 2- 1: Selectable signals for each video format

Format	Selectable signals
NTSC and NTSC No Setup	Black Burst, Black Burst with Field REF, Black Burst with 10 Field ID*, 100% Color Bars*, 75% Color Bars*, SMPTE Color Bars*, 40 % Flat Field*, Other 1*, Other 2*
PAL	Black Burst, Black Burst No Field REF, 100% Colour Bars*, 75% Colour Bars *, 100% Colour Bars Over Red*, 75% Colour Bars Over Red*, 40 % Flat Field*, Other 1*, Other 2*
HD SYNC	1080 60i, 1080 59.94i, 1080 50i, 1080 24sF, 1080 23.98sF, 1080 30p, 1080 29.97p, 1080 25p, 1080 24p, 1080 23.98p, 720 60p, 720 59.94p, 720 50p

* These signals are only provided with Option CB, and are only available through the BLACK 3 and BLACK 4 connectors.

TIMING Submenu

This menu allows you to adjust the timing offset of the selected black signal outputs relative to the genlock signal or the internal reference signal. Use the up (▲) or down (▼) arrow button to select between Vertical and Horizontal. Figure 2-4 shows the TIMING submenu.

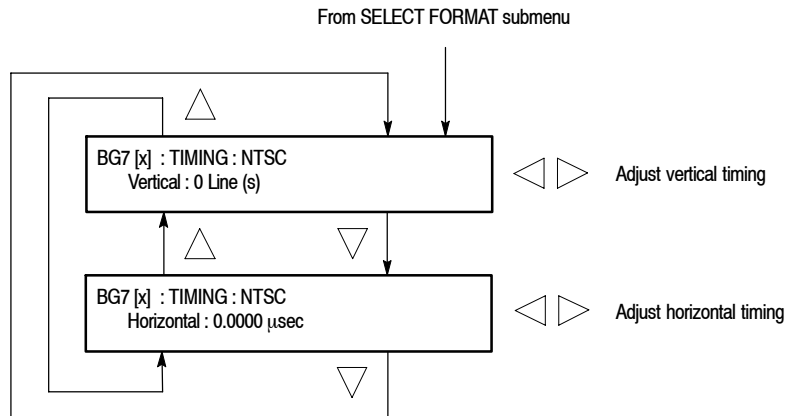

Figure 2- 4: TIMING submenu

- **Vertical** : Use the left (◀) or right (▶) arrow button to adjust the vertical offset. For NTSC or PAL format signal, you can set the value from -1/2 color frame to +1/2 color frame in 1 line steps. For the HDTV trilevel sync signal, you can set the value from -1/2 frame to +1/2 frame in 1 line steps.

- **Horizontal** : Use the left (◀) or right (▶) arrow button to adjust the horizontal offset. You can set the value from -1 line to +1 line in one clock steps (18.5 ns for NTSC or PAL, 13.5 ns for HDTV).

NOTE. You can reset the timing offset to zero by pressing the left (◀) and right (▶) arrow buttons simultaneously.

The BG7 horizontal timing can only be adjusted in clock cycle increments. You can match the AGL7 timing to the BG7 by adjusting the AGL7 fine timing controls.

Rear-Panel Connectors

The BG7 Generator module is equipped with four BNC connectors of BLACK 1, BLACK 2, BLACK 3, and BLACK 4, and can output a black burst signal or HDTV trilevel sync signal from each output connector. Option CB adds the capability to output a field ID signal and NTSC/PAL color bars in addition to a black burst signal. Figure 2-5 shows the BG7 Generator module rear-panel connectors.

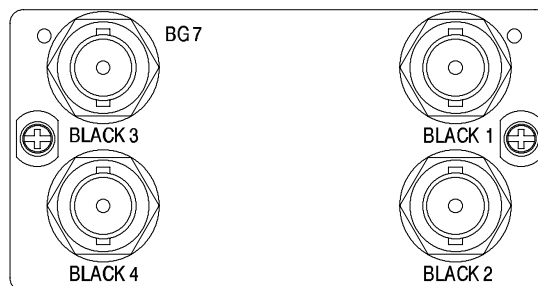

Figure 2-5: BG7 module rear-panel connectors

- **BLACK 1** : Black burst signal and HDTV trilevel sync signal output.
- **BLACK 2** : Black burst signal and HDTV trilevel sync signal output.
- **BLACK 3** : Black burst signal and HDTV trilevel sync signal output. With Option CB installed this connector can also output a 10 field ID signal and color bars.
- **BLACK 4** : Black burst signal and HDTV trilevel sync signal output. With Option CB installed this connector can also output a 10 field ID signal and color bars.

Factory Default Settings

Table 2-2 shows the factory default settings for the BG7 Generator module. These settings are recalled when you select **Factory Default** from the **PRESET : RECALL** menu item in the mainframe main menu.

Table 2-2: Factory default settings

Menu item name	Settings
OUTPUT : BLACK 1 to BLACK 4	
Format	NTSC
SIGNAL	Black Burst
TIMING	
Vertical	0 Line(s)
Horizontal	0.0000 μ sec



Reference

Syntax

This section contains information on the Standard Commands for Programmable Instruments (SCPI) and the programming structure you can use to program your BG7 Generator module.

Programming Model

Specific conditions must exist before programming commands will affect the test signal generated by a module.

Selecting the Module

Select the module using the :INSTRument:SElect command before executing any commands. Many of the commands used by the BG7 module are shared by several modules and will be accepted without a reported error.

Command Arguments

Many commands will accept either string or numeric arguments. For example: a boolean argument can either be "1" or "ON".

Signal parameter commands that have a :STEP node can accept either a numeric value or they can accept a string argument that refers to the :STEP increment.

Signal parameter commands with a :STEP node will accept the following strings in addition to a numeric value:

UP. Use this argument to increase the parameter value one increment as defined by the :STEP value.

DOWN. Use this argument to decrease the parameter value one increment as defined by the :STEP value.

MINimum. Use this argument to set the parameter value to the minimum acceptable value.

MAXimum. Use this argument to set the parameter value to the maximum acceptable value.

DEFault. Use this argument to set the parameter value to the default value.

Query Arguments

If you send a query with no argument, the response is the current value. You can also use **MINimum**, **MAXimum**, and **DEFault** as arguments for queries whose command form can use these arguments (refer to the command syntax for the specific command). Instead of returning the current value, queries using these arguments return the following information:

MINimum. Return the minimum acceptable value.

MAXimum. Return the maximum acceptable value.

DEFault. Return the default value.

Argument Example

The following example demonstrates the effect of each of the arguments when used with a step value.

1. `:INSTRument:SElect "HDVG7:#"` selects the digital video generator module located in the slot number indicated by the “#” symbol.
2. `:OUTPut:CIRClE:STATe ON` displays a circle on the video display.

NOTE. `:OUTPut:CIRClE:DIAMeter` uses an argument that is the percent of picture height.

3. `:OUTPut:CIRClE:DIAMeter DEFaul t` sets the circle diameter to 90 percent of the screen height.
4. `:OUTPut:CIRClE:DIAMeter:STEP 10` sets the step increment to 10 percent.
5. `:OUTPut:CIRClE:DIAMeter DOWN` changes the circle diameter to 80 percent of the screen height.
6. `:OUTPut:CIRClE:DIAMeter 50` changes the circle diameter to 50 percent of the screen height.
7. `:OUTPut:CIRClE:DIAMeter MAXimum` changes the circle diameter to 100 percent of the screen height.
8. `:OUTPut:CIRClE:DIAMeter MINimum` changes the circle diameter to 0 percent of the screen height.
9. `:OUTPut:CIRClE:DIAMeter UP` changes the circle diameter to 10 percent of the screen height.
10. `:OUTPut:CIRClE:DIAMeter? MAXimum` queries the maximum circle diameter (not the current diameter). The query returns the value of 100 percent, which is the maximum circle diameter allowable.

SCPI Commands and Queries

SCPI is a standard created by a consortium that provides guidelines for remote programming of instruments. These guidelines provide a consistent programming environment for instrument control and data transfer. This environment uses defined programming messages, instrument responses, and data format across all SCPI instruments, regardless of manufacturer. The BG7 Generator module uses a command language based on the SCPI standard.

The SCPI language is based on a hierarchical or tree structure (see Figure 3-1) that represents a subsystem. The top level of the tree is the root node; it is followed by one or more lower-level nodes.

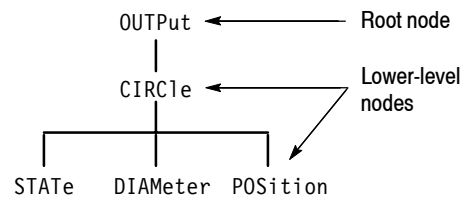

Figure 3-1: Example of SCPI subsystem hierarchy

You can create commands and queries from these subsystem hierarchy trees. Commands specify actions for the instrument to perform. Queries return measurement data and information about parameter settings.

For more information on SCPI commands and programming structure, refer to the *TG700 Signal Generator Platform User Manual*.

Remote Commands

This section describes the command sets used for the BG7 Generator module remote operation. The commands for the module are divided into the following groups:

- OUTPUT commands
- SENSE commands

OUTPUT Commands

Use these commands to set the video standard and the kind of signal for the BLACK outputs.

Command Tree

```
:OUTPut
  :CONFigure?
:OUTPut<n>
  :STANdard
    NTSC|NTSC_NSU|PAL|HD1080_60I|
    HD1080_59I|HD1080_50I|HD1080_24SF|
    HD1080_23SF|HD1080_30P|HD1080_29P|
    HD1080_25P|HD1080_24P|HD1080_23P|
    HD720_60P|HD720_59P|HD720_50P
  :SIGNal
    BB|BB_FREF|BB_10FID|CB100PER|
    CB75PER|CB_SMPTE|FF40PER|OTHER_ONE|
    OTHER_TWO|BB_NO_FREF|CB100_OR|CB75_OR
```

Command Description

:OUTPut:CONFigure?

Returns the availability of color bars signal output option (Option CB). “1” indicates that the option is available and “0” indicates the option is not available.

```
:OUTPut<n>:STANdard NTSC|NTSC_NSU|PAL|HD1080_60I|HD1080_59I|
HD1080_50I|HD1080_24SF|HD1080_23SF|
HD1080_30P|HD1080_29P|HD1080_25P|
HD1080_24P|HD1080_23P|HD720_60P|HD720_59P|
HD720_50P
```

Sets the video standard for a specific BLACK output. The choices are NTSC, PAL, NTSC_NSU (NTSC no setup), and HD1080_60I to HD720_50P. The <n> in the command represents the connector number. You can use any connector number from 1 through 4.

```
:OUTPut<n>:STANdard?
```

Returns the video standard for a specific BLACK output. The <n> in the command represents the connector number. You can use any connector number from 1 through 4.

```
:OUTPut<n>:SIGNal BB|BB_FREF|BB_10FID|CB100PER|CB75PER|
CB_SMPTE|FF40PER|OTHER_ONE|OTHER_TWO|
BB_NO_FREF|CB100_OR|CB75_OR
```

Sets what kind of signal is available from a specific BLACK output. The <n> in the command represents the connector number. You can use any connector number from 1 through 4.

If the standard is NTSC or NTSC_NSU, the options are BB (black burst) or BB_FREF (black burst with field reference). With Option CB you can also select BB_10FID (black burst with 10 field ID), CB100PER (100 % color bars), CB75PER (75 % color bars), CB_SMPTE (SMPTE color bars), FF40PER (40 % flat field), OTHER_ONE (Other 1), or OTHER_TWO (Other 2).

If the standard is PAL, the options are BB (black burst) or BB_NO_FREF (black burst no field reference). With Option CB you can also select CB100PER (100 % colour bars), CB75PER (75 % colour bars) CB_100_OR (100 % colour bars over red), CB_75_OR (75 % colour bars over red), FF40PER (40 % flat field), OTHER_ONE (Other 1), or OTHER_TWO (Other 2).

```
:OUTPut<n>:SIGNal?
```

Returns the current output signal. The <n> in the command represents the connector number. You can use any connector number from 1 through 4.

SENSE Commands

Use these commands to adjust the timing offset of the BLACK outputs relative to the internal reference signal (frame reset signal).

Refer to *Operating Basics* about the timing offset range.

Command Tree

```
:SENSe<n>
  :CORRection
    :MDElay
      :HORizontal      <numeric_value>
        :STEP          <numeric_value>
      :VERTical        <numeric_value>
        :STEP          <numeric_value>
```

Command Description

```
:SENSe<n>:CORRection:MDElay:HORizontal <numeric_value>
```

Sets the horizontal timing offset of a specific BLACK output. The timing resolution is clock-cycles. The unit is microseconds. You can use UP, DOWN, or DEF instead of the numeric values. If the argument exceeds the horizontal time value, then the vertical offset is adjusted to accommodate the requested offset. The <n> in the command represents the connector number. You can use any connector number from 1 through 4.

```
:SENSe<n>:CORRection:MDElay:HORizontal?
```

Returns the horizontal timing offset of a specific BLACK output. The <n> in the command represents the connector number. You can use any connector number from 1 through 4.

```
:SENSe<n>:CORRection:MDElay:HORizontal:STEP <numeric_value>
```

Sets the step increment used by the UP or DOWN commands. The unit is microseconds. You can use UP, DOWN, or DEF instead of the numeric values. The <n> in the command represents the connector number. You can use any connector number from 1 through 4.

```
:SENSe<n>:CORRection:MDElay:HORizontal:STEP?
```

Returns the step increment used by the UP or DOWN commands. The <n> in the command represents the connector number. You can use any connector number from 1 through 4.

`:SENSe<n>:CORRection:MDELay:VERTical <numeric_value>`

Sets the vertical timing offset of a specific BLACK output. The argument can be a floating point value that is translated into integer lines with a horizontal offset. You can use UP, DOWN, or DEF instead of a numeric value. The <n> in the command represents the connector number. You can use any connector number from 1 through 4.

`:SENSe<n>:CORRection:MDELay:VERTical?`

Returns the vertical timing offset of a specific BLACK output. The <n> in the command represents the connector number. You can use any connector number from 1 through 4.

`:SENSe<n>:CORRection:MDELay:VERTical:STEP <numeric_value>`

Sets the step increment used by the UP or DOWN commands. You can use MIN, MAX, or DEF instead of the numeric values. The <n> in the command represents the connector number. You can use any connector number from 1 through 4.

`:SENSe<n>:CORRection:MDELay:VERTical:STEP?`

Returns the step increment used by the UP or DOWN commands. The <n> in the command represents the connector number. You can use any connector number from 1 through 4.



Appendices

Appendix A: Specifications

Tables A-1 through A-3 list the electrical characteristics and the environmental characteristics of the BG7 Generator module.

Electrical Characteristics

Table A- 1: Black burst and HDTV trilevel sync outputs

Characteristic	Performance requirements	Reference information
Connector	BNC	
Number of outputs	4	BLACK1, BLACK2, BLACK3, and BLACK4
Output impedance, typical	75 Ω	
Return loss	≥ 30 dB	To 30 MHz
Burst amplitude accuracy	$\pm 2\%$	NTSC and PAL
Sync amplitude accuracy		
NTSC/PAL	$\pm 2\%$	
TriLevel	$\pm 2\%$	
Blanking level	0 ± 50 mV	
SCH phase accuracy	$0^\circ \pm 5^\circ$	
Timing offset		
Range	Full color frame	
Resolution		
NTSC/PAL	$1/54 \mu\text{s}$	≈ 18.5 ns
TriLevel	$1/74.25 \mu\text{s}$ or $1/(74.25/1.001) \mu\text{s}$	≈ 13.9 ns

Table A-2: Color bars and black burst with field ID outputs (option CB)

Characteristic	Performance requirements	Reference information
Color bars signals		
NTSC		100% Color Bars, 75% Color Bars, SMPTE Color Bars, 40% Flat Field, SNG Color Bar, Monitor Setup Matrix
NTSC No Setup		100% Color Bars, 75% Color Bars, SMPTE Color Bars, 40 % Flat Field, SNG Color Bar, Monitor Setup Matrix
PAL		100% Colour Bars, 75% Colour Bars, 100% Colour Bars Over Red, 75% Colour Bars Over Red, 40% Flat Field, SNG Colour Bars, 4 Level Pluge, Monitor Setup Matrix
Black burst with field ID		
Luminance amplitude accuracy	± 1%	Measured at 700 mV.
Chrominance to luminance gain	± 2%	Chrominance is measured at red portion of the 75% Colour Bars Over Red signal.

Environmental Characteristics

Table A-3: Environmental characteristics

Characteristic	Description
Temperature	
Operating	0 °C to +50 °C
Nonoperating	-20 °C to +60 °C
Relative Humidity	
Operating	20% to 80% (No condensation); Maximum wet-bulb temperature 29.4° C
Nonoperating	5% to 90% (No condensation); Maximum wet-bulb temperature 40.0° C
Altitude	
Operating	To 4.5 km (15,000 feet) Maximum operating temperature decreases 1 °C each 300 m above 1.5 km.
Nonoperating	To 15 km (50,000 feet)
Vibration	
Operating	3.04 m/s ² (0.31 G _{rms}), 5 Hz to 500 Hz, 10 min, three axes
Nonoperating	23.3 m/s ² (2.38 G _{rms}), 5 Hz to 500 Hz, 10 min, three axes
Shock	
Nonoperating	294 m/s ² (30 G), half-sine, 11 ms duration



Index

Index

A

Accessories
 optional, 1-1
 standard, 1-1

B

BG7 features, 1-1
BG7 module main menu, 2-2
 SELECT OUTPUT, 2-2
BLACK 1 connector, 2-5
BLACK 2 connector, 2-5
BLACK 3 connector, 2-5
BLACK 4 connector, 2-5

C

Commands
 Rules for forming, 3-1
 Syntax, 3-1

E

Electrical specifications, A-1
Environmental specifications, A-2

F

Factory default settings, 2-6
Functional check, 1-2
Functional command groups, 3-5

H

Hierarchy (SCPI), 3-3

I

Installation, 1-2

M

Manuals, Related, iii

O

Operating procedure, 2-1
Optional accessories, 1-1
Options, 1-2
OUTPUT comands, 3-5

P

Product description, 1-1

R

Rear-panel connectors, 2-5
Related Manuals, iii
Rules, Command forming, 3-1

S

SCPI, Subsystem hierarchy tree, 3-3
SCPI commands and queries syntax, 3-3-3-4
SELECT FORMAT submenu, 2-2
SELECT SIGNAL submenu, 2-3
SENSE commands, 3-7
Specifications
 Electrical, A-1
 Environmental, A-2
Standard accessories, 1-1
Syntax, Command, 3-1

T

TIMING submenu, 2-4

User Manual



DVG7 Digital Video Generator

Copyright © Tektronix. All rights reserved. Licensed software products are owned by Tektronix or its suppliers and are protected by United States copyright laws and international treaty provisions.

Tektronix products are covered by U.S. and foreign patents, issued and pending. Information in this publication supercedes that in all previously published material. Specifications and price change privileges reserved.

TEKTRONIX and TEK are registered trademarks of Tektronix, Inc.

Contacting Tektronix

Tektronix, Inc.
14200 SW Karl Braun Drive
P.O. Box 500
Beaverton, OR 97077
USA

For product information, sales, service, and technical support:

- In North America, call 1-800-833-9200.
- Worldwide, visit www.tektronix.com to find contacts in your area.

Table of Contents

Preface	iii
About This Manual	iii
Related Manuals	iii
Getting Started	
Product Description	1-1
Accessories	1-2
Options	1-2
Installation	1-3
Functional Check	1-3
Operating Basics	
Operating Procedure	2-1
Selecting an Output Signal	2-2
DVG7 Module Main Menu	2-6
Rear-Panel Connectors	2-22
Factory Default Settings	2-23
Reference	
Syntax	3-1
Programming Model	3-1
SCPI Commands and Queries	3-3
Remote Commands	3-5
MASS MEMORY Commands	3-5
OUTPUT Commands	3-6
SENSE Commands	3-16
Appendices	
Appendix A: Specifications	A-1
Electrical Characteristics	A-1
Environmental Characteristics	A-2
Index	

List of Figures

Figure 2-1: Front-panel test signal buttons	2-3
Figure 2-2: DVG7 module main menu	2-6
Figure 2-3: MOVING PICTURE submenu	2-8
Figure 2-4: OVERLAY submenu	2-9
Figure 2-5: LOGO submenu	2-10
Figure 2-6: ID TEXT submenu	2-11
Figure 2-7: CIRCLE submenu	2-13
Figure 2-8: AUDIO GROUP submenu	2-14
Figure 2-9: AUDIO CHANNEL submenu	2-15
Figure 2-10: TIMING submenu	2-17
Figure 2-11: VIDEO submenu	2-18
Figure 2-12: BLACK submenu (Option BK only)	2-20
Figure 2-13: DVG7 module rear-panel connectors (Option BK) ...	2-22
Figure 3-1: Example of SCPI subsystem hierarchy	3-3

List of Tables

Table 1-1: Standard and optional accessories	1-2
Table 2-1: Signal set assigned to the test signal buttons	2-3
Table 2-2: Factory default settings	2-23
Table A-1: Serial digital video signal outputs	A-1
Table A-2: Serial digital black signal outputs (Option BK only) ..	A-1
Table A-3: Embedded audio	A-2
Table A-4: Environmental characteristics	A-2

Preface

This manual documents the capabilities, operation, and specifications of the DVG7 Digital Video Generator module.

About This Manual

This manual is composed of the following sections:

- *Getting Started* contains product description and functional check procedure.
- *Operating Basics* explains how to operate the DVG7 module using the menus and front-panel buttons.
- *Reference* provides the syntax used in command descriptions and describes all programming commands.
- *Appendices* provides the specifications.

Related Manuals

The following documents are also available.

- The *TG700 TV Signal Generator Platform Service Manual* (Tektronix part number 070-A800-XX) describes how to maintain and service the mainframe and generator modules. This manual is an optional accessory.
- The *TG700 TV Signal Generator Platform Module Installation Instructions* (Tektronix part number 070-A824-XX) describes how to install and remove the modules, and how to upgrade the firmware of the mainframe.



Getting Started

Getting Started

This section contains the following information:

- Product description
- Accessories
- Options
- Installation
- Functional check

Product Description

The DVG7 Digital Video Generator module is designed to be installed in the TG700 TV Signal Generator Platform.

The module is a digital video generator which provides NTSC composite digital signals and 525/625 component digital signals. The module contains the following features:

- Two serial digital video outputs
- Two serial digital black outputs (Option BK)
- Overlay of circle, text, or logo on the video signal
- Generates a moving picture by scrolling the active picture area of the output test signal
- Up to 16 channels of Embedded Audio
- Full remote control using Ethernet interface

The module can generate video signals with 24 (or 20) bit embedded digital audio with a sample rate of 48 kHz.

The following audio frequencies are supported.

Silence	500 Hz	2000 Hz	8000 Hz
50 Hz	600 Hz	2400 Hz	9600 Hz
100 Hz	750 Hz	3000 Hz	10000 Hz
150 Hz	800 Hz	3200 Hz	12000 Hz
200 Hz	1000 Hz	4000 Hz	15000 Hz
250 Hz	1200 Hz	4800 Hz	16000 Hz
300 Hz	1500 Hz	5000 Hz	20000 Hz
400 Hz	1600 Hz	6000 Hz	

Accessories

Table 1-1 lists the standard and optional accessories provided with the DVG7 Generator module.

Table 1-1: Standard and optional accessories

Accessory	Std.	Opt.	Tektronix part number
TG700 TV Signal Generator Platform Module Installation Instructions	●		070-A824-XX
TG700 Signal Generator Platform Software Library CD-ROM	●		062-A249-XX
TG700 TV Signal Generator Platform Service Manual		●	070-A800-XX

Options

This subsection describes the options available for the DVG7 Generator module. The following options are available:

Option BK (Serial digital black output)

Option D1 (Test data report)

Option BK (Serial Digital Black Output)

Two serial digital black signal outputs are added to the DVG7 Generator module when this option is specified.

Option D1 (Test Data Report)

A calibration test data report will be provided with the DVG7 Generator module when this option is specified.

Installation

Refer to the *TG700 TV Signal Generator Platform Module Installation Instructions* for instructions on how to install the DVG7 Generator module.

Functional Check

The following procedure determines whether the module is operating correctly.

Required equipment

The following equipment is required for the functional check:

- Serial digital waveform monitor
- 75 Ω BNC cable

Procedure

1. Install the module into the TG700 Platform mainframe using the installation procedures described in the *TG700 TV Signal Generator Platform User Manual*.
2. Power on the TG700 TV Signal Generator Platform by connecting it to the power source. The initialization of all the installed modules is executed.
3. Check that no error messages appear on the LCD display.
4. Warm up the instrument for 20 minutes.
5. Press the front-panel **MODULE** button until the DVG7 main menu shown below appears.



DVG7 [x] : STATUS : 525-270
100% Color Bars

6. Press the **FORMAT** button and use the left (◀) or right (▶) arrow button to select a format, then press the **ENTER** button.
7. Press one of the front-panel test signal buttons (for example **COLOR BAR**) to output a signal.
8. Connect the **SIGNAL 1** connector to the serial digital waveform monitor using the 75 Ω BNC cable.
9. Set the waveform monitor to view the signal.
10. Check that the signal appears as expected. For example, if you selected a color bar signal in step 7, check that the color bar signal appears.

- 11.** Disconnect the BNC cable from the **SIGNAL 1** connector, and then connect the BNC cable to the **SIGNAL 2** connector.
- 12.** Check that the signal appears as expected.



Operating Basics

Operating Basics

This section explains the operation of the DVG7 Generator module using the front-panel buttons and menus. It also contains descriptions of the rear-panel connectors.

Refer to the *TG700 TV Signal Generator Platform User Manual* for a detailed explanation of the front-panel buttons and the LCD display.

Operating Procedure

After the module is installed in the mainframe, and the mainframe is installed in the rack or other location where it will be used, access each function of the module with the following procedure:

1. Connect the power connector on the rear panel to the AC electric power source using the power cord.

Electric power is supplied to the mainframe.

2. Wait until the power up initialization process is complete, and check that no error messages appear on the display.
3. Following the initialization process the mainframe main menu appears, as shown below.



TG700: PRESET

4. Press the front-panel **MODULE** button until the DVG7 module main menu appears, as shown below.



DVG7 [x]: STATUS: 525-270
100% Color Bars

5. Select the signal format and the signal you want to output. Refer to *Selecting an Output Signal* on page 2-2 for more information.
6. Press the front-panel arrow buttons to select the desired main menu item or submenu item.

Refer to *DVG7 Module Main Menu* beginning on page 2-6 for detailed information about the main menu items and the submenu items.

Selecting an Output Signal

When you output a signal from the DVG7 Generator module, you need to select a signal format and output signal. This subsection provides instructions on how to output a signal.

Selecting a Format

If you press the front-panel **FORMAT** button when the DVG7 Generator module is selected (active), you can select the format for the output signals.

Perform the following steps to select the format:

1. Confirm that any menu item of the DVG7 module main menu is displayed. If the menu is not displayed, press the front-panel **MODULE** button until the DVG7 module main menu appears, as shown below.



```
DVG7 [x] : STATUS : 525-270
100% Color Bars
```

2. Press the **FORMAT** button. The menu display changes as follows:

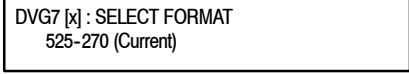

```
DVG7 [x] : SELECT FORMAT
525-270 (Current)
```

3. Press the left (◀) or right (▶) arrow button to select one of the signal formats, and then press the **ENTER** button to confirm the selection.

NOTE. When you change signal format, synchronization shock occurs.

When you change the format while a signal is output, the instrument starts loading all of the signal set for the format and displays the message “**Now Loading...**”. When you see the message, “**Done (Press CANCEL)**”, press the **CANCEL** button.

Selecting a Signal

All signal sets available in the module are already assigned to the corresponding test signal buttons (see Figure 2-1). When you press any of the buttons, one of the signals in the signal set is output.

For example, when you press the **COLOR BAR** test signal button, you can output the **100% Color Bars** signal in the Color Bars signal set.

Press the left (◀) or right (▶) arrow button, or press the test signal button repeatedly to select different signals assigned to the test signal button.

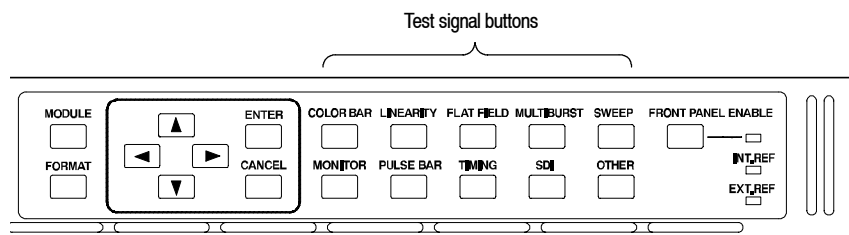

Figure 2- 1: Front-panel test signal buttons

Table 2-1 lists the signal set assigned to each test signal button and the signals that can be selected in the signal set. The signals available in each signal set are different from one signal format to another.

Table 2- 1: Signal set assigned to the test signal buttons

Button name	Signal set	Signals in the signal set
525- 143 format		
COLOR BAR	Color Bars	100% Color Bars, 75% Color Bars, SMPTE Color Bars
LINEARITY	Linearity	10 Step, 5 Step, Luminance Ramp, Mod Shallow Ramp, Modulated 10 Step, Modulated 5 Step, Modulated Pedestal, Modulated Ramp, Shallow Ramp, Shallow Ramp Matrix
FLAT FIELD	Flat Fields	0% Flat Field, 100% Flat Field, 50 % Flat Field, Black Burst, Field Square Wave
MULTI BURST	Multi Burst	60 IRE Multiburst, Multipulse
SWEEP	Sweep	6 MHz Sweep, SinX/X
MONITOR	Monitor	100% Red Field, 2 Level Ped. & Pluge, 4 Level Ped. & Pluge, 75% Red Field, Convergence Pattern, Grey Window, Monitor Matrix, Monitor Setup, White Window
PULSE BAR	Pulse & Bar	Window 1T Pulse & Bar, Window 2T Pulse & Bar
TIMING	-----	-----
SDI	SDI Test	Equalizer Test, PLL Test, SDI Matrix
OTHER	Other	FCC Composite, FCC Multiburst, NTC7 Combination, NTC7 Composite

Table 2- 1: Signal set assigned to the test signal buttons (Cont.)

Button name	Signal set	Signals in the signal set
525- 270 format		
COLOR BAR	Color Bars	100% Color Bars, 75% Color Bars, SMPTE Color Bars
LINEARITY	Linearity	10 Step, 3 Channel Ramp, 5 Step, B-Y Valid Ramp, Limit Ramp, Modulated Ramp, Oversize Ramp, R-Y Valid Ramp, Shallow Ramp, Shallow Ramp Matrix, Valid Ramp, Y Valid Ramp
FLAT FIELD	Flat Fields	0% Flat Field, 100% Flat Field, 50 % Flat Field, Field Square Wave
MULTI BURST	Multi Burst	60% Multiburst, Multipulse
SWEEP	Sweep	100% Sweep, 60% Sweep, SinX/X
MONITOR	Monitor	2 Level Ped. & Pluge, 4 Level Ped. & Pluge, Convergence Pattern, Gamut Test, Grey Window, White Window
PULSE BAR	Pulse & Bar	2T Pulse and Bar, T Pulses
TIMING	Timing	2.5 MHz Bowtie, 500 kHz Bowtie, Active Picture Timing, Co-Siting Pulse
SDI	SDI Test	Equalizer Test, PLL Test, SDI Matrix
OTHER	Other	Chroma Freq. Resp., Color Palette, FCC Composite, FCC Multiburst, NTC7 Combination, NTC7 Composite

Table 2- 1: Signal set assigned to the test signal buttons (Cont.)

Button name	Signal set	Signals in the signal set
625-270 format		
COLOR BAR	Color Bars	100% Colour Bars, 75% Colour Bars, 100% Colour Bars Over Red, 75% Colour Bars Over Red
LINEARITY	Linearity	10 Step, 3 Channel Ramp, 5 Step, B-Y Valid Ramp, Limit Ramp, Modulated Ramp, Oversize Ramp, R-Y Valid Ramp, Shallow Ramp, Shallow Ramp Matrix, Y Valid Ramp
FLAT FIELD	Flat Fields	0% Flat Field, 100% Flat Field, 50 % Flat Field, Field Square Wave
MULTI BURST	Multi Burst	60% Multiburst
SWEEP	Sweep	100% Sweep, 60% Sweep, SinX/X
MONITOR	Monitor	100% Red Field, 2 Level Ped. & Pluge, 4 Level Ped. & Pluge, 75% Red Field, Convergence Pattern, Gamut Test, Grey Window, White Window
PULSE BAR	Pulse & Bar	2T 4T 10T Pulse & Bar, 2T 4T 20T Pulse & Bar
TIMING	Timing	2.5 MHz Bowtie, 500 kHz Bowtie, Active Picture Timing, Co-Siting Pulse
SDI	SDI Test	Equalizer Test, PLL Test, SDI Matrix
OTHER	Other	CCIR 17, CCIR 18, CCIR 330, CCIR 331, CCIR 331 G2

If you want to output custom signals from the module, you must assign the signal set to one of the test signal buttons. Refer to *TG700 TV Signal Generator Platform User Manual* for detailed information about how to assign a signal set to a test signal button.

DVG7 Module Main Menu

You can set the logo, circle, and text overlay, embedded audio, timing offset of the serial digital signal outputs using the DVG7 module main menu.

Use the up (▲) or down (▼) arrow button to scroll through the main menu. Figure 2-2 shows the DVG7 module main menu.

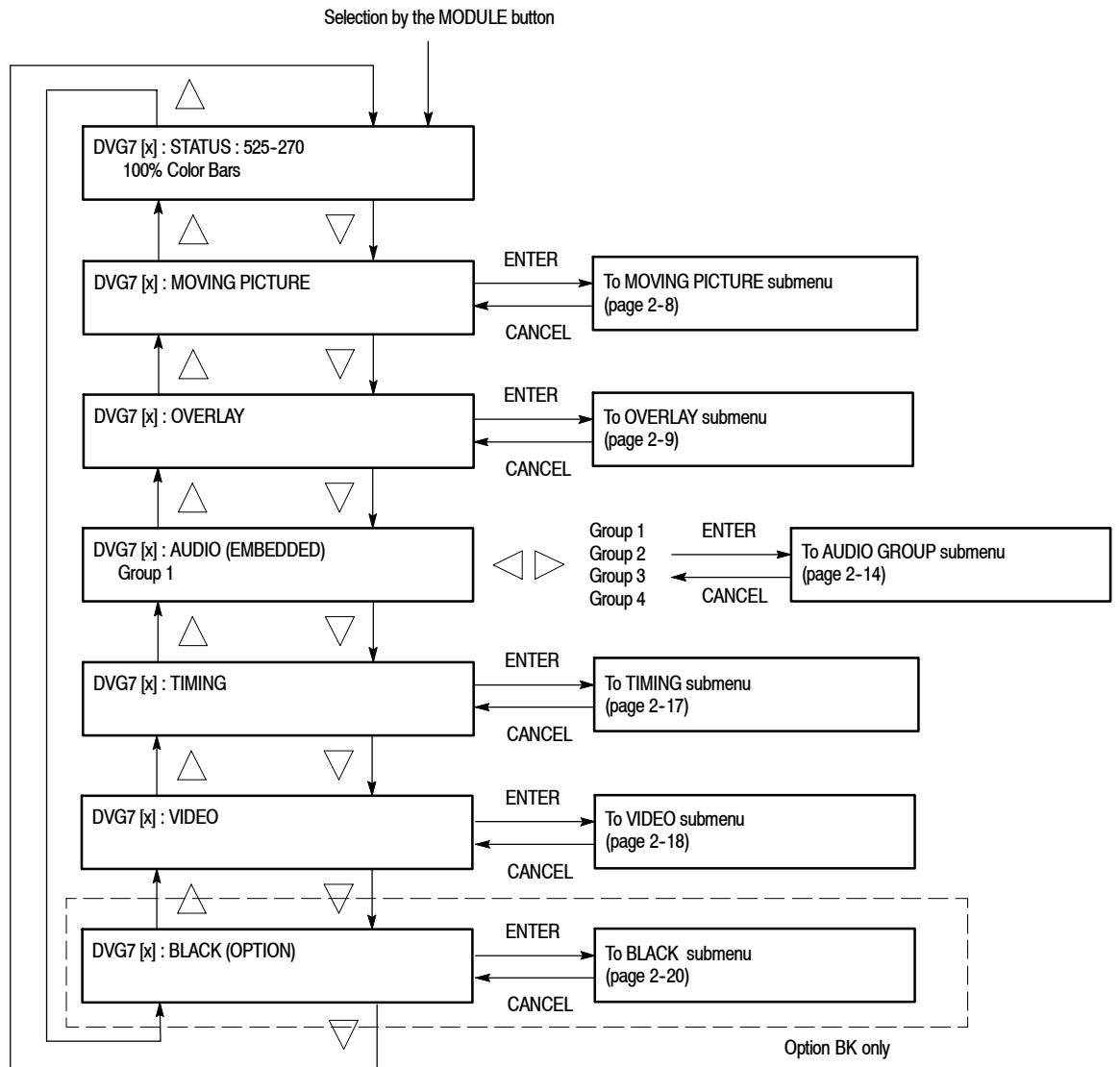

Figure 2-2: DVG7 module main menu

MOVING PICTURE. Scrolls the active picture area of the output test signal. When you select this menu item and then press the ENTER button, you will access the MOVING PICTURE submenu. Refer to *MOVING PICTURE Submenu* on page 2-8 for detailed information.

OVERLAY. Selects an item (logo, text, or circle) that is overlaid on the output test signal and sets the blinking mode for the overlay. When you select this menu item and then press the ENTER button, you will access the OVERLAY submenu. Refer to *OVERLAY Submenu* on page 2-9 for detailed information.

AUDIO (EMBEDDED). Sets the parameters for embedded audio on the output test signals. Use the left (◀) or right (▶) arrow button to select **Group 1**, **Group 2**, **Group 3**, or **Group 4**. When you select any of the items and then press the ENTER button, you will access the AUDIO GROUP submenu. Refer to *AUDIO GROUP Submenu* on page 2-14 for detailed information.

TIMING. Sets the timing offset of the serial digital video outputs relative to the internal reference signal (frame reset signal). When you select this menu item and then press the ENTER button, you will access the TIMING submenu. Refer to *TIMING Submenu* on page 2-17 for detailed information.

VIDEO. Enables or disables the Y, Pb, or Pr component of the output serial digital video signals, the EDH (Error Detection Handling) insertion, and the output mode for an audio/video timing measurement. You can also set the resolution of the output serial digital video signals. When you select this menu item and then press the ENTER button, you will access the VIDEO submenu. Refer to *VIDEO Submenu* on page 2-18 for detailed information.

BLACK (OPTION). This menu is only available with Option BK, and sets the parameters of the serial digital black signals output from the **BLACK 1** and **BLACK 2** connectors. When you select this menu item and then press the ENTER button, you will access the BLACK submenu. Refer to *BLACK Submenu* on page 2-20 for detailed information.

**MOVING PICTURE
Submenu**

This menu allows you to scroll the active picture area of the serial digital video signal up/down or left/right (or randomly). Use the up (▲) or down (▼) arrow button to scroll the menu. Figure 2-3 shows the MOVING PICTURE submenu.

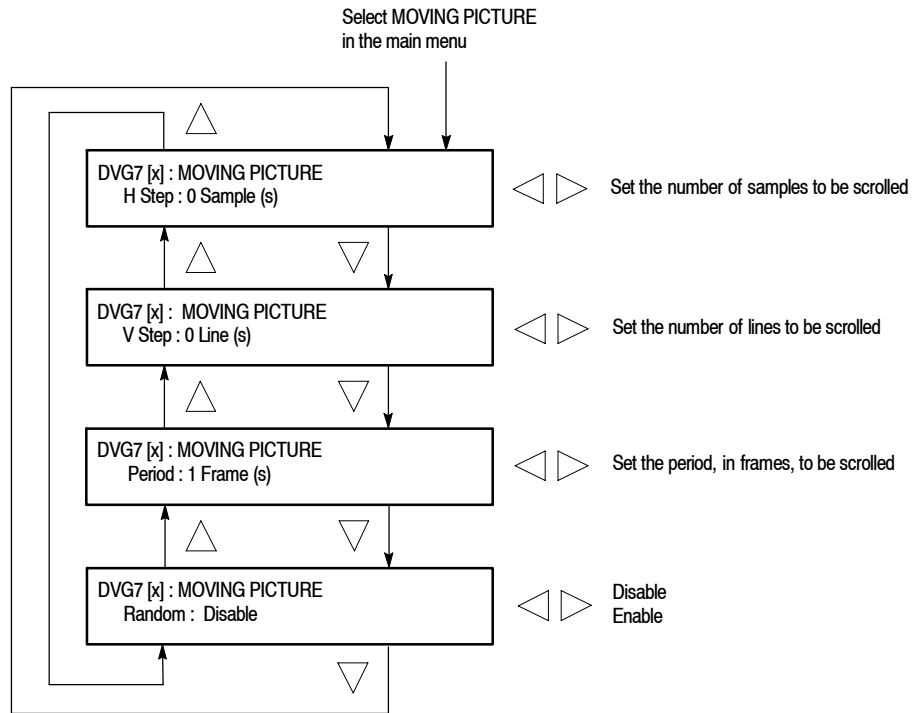

Figure 2-3: MOVING PICTURE submenu

- **H Step:** Sets the number of samples to be scrolled per frame set in the **Period** menu item. Use the left (◀) or right (▶) arrow button to change the value. You can set the value from -252 to +252 in 4 samples steps.
- **V Step:** Sets the number of lines to be scrolled per frame set in the **Period** menu item. Use the left (◀) or right (▶) arrow button to change the value. You can set the value from -252 to +252 in 1 line steps.
- **Period:** Sets the time interval between occurrences of the scrolling. Use the left (◀) or right (▶) arrow button to change the value. You can set the value from 1 to 16 in 1 frame steps.
- **Random:** Sets whether or not the picture scrolls randomly. Use the left (◀) or right (▶) arrow button to select between **Disable** and **Enable**. Press the **ENTER** button to confirm the selection.

OVERLAY Submenu

This menu allows you to select an item (logo, ID Text, or circle) to overlay on the output test signal, and to set the blinking mode for the overlay. Use the up (▲) or down (▼) arrow button to scroll through the menu. Figure 2-4 shows the OVERLAY submenu.

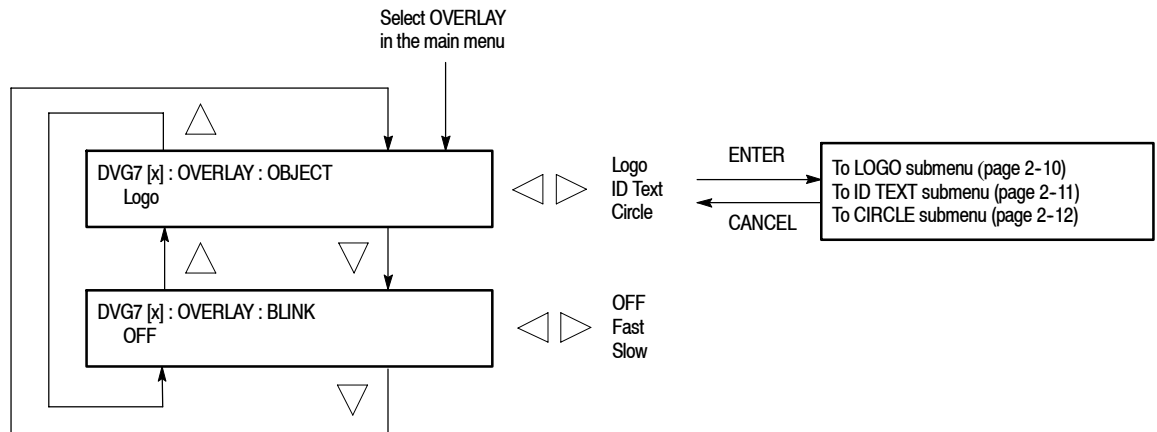

Figure 2-4: OVERLAY submenu

- **OBJECT:** Selects an item that is overlaid on the output test signal. Use the left (◀) or right (▶) arrow button to select **Logo**, **ID Text**, or **Circle**. When you select any of these items and then press the ENTER button, you will access the submenu for setting that overlay. Refer to *LOGO Submenu* on page 2-10, *ID TEXT Submenu* on page 2-11, or *CIRCLE Submenu* on page 2-12 for detailed information.
- **BLINK:** Sets the blinking mode for the overlay. Use the left (◀) or right (▶) arrow button to select **OFF**, **Fast** (blinks approximately at 0.5 second interval), or **Slow** (blinks approximately at 1.0 interval). Press the **ENTER** button to confirm the selection.

LOGO Submenu

This menu allows you to select a logo to overlay on the output test signal, and to set the display position of the logo. Use the up (▲) or down (▼) arrow button to scroll through the menu. Figure 2-5 shows the LOGO submenu.

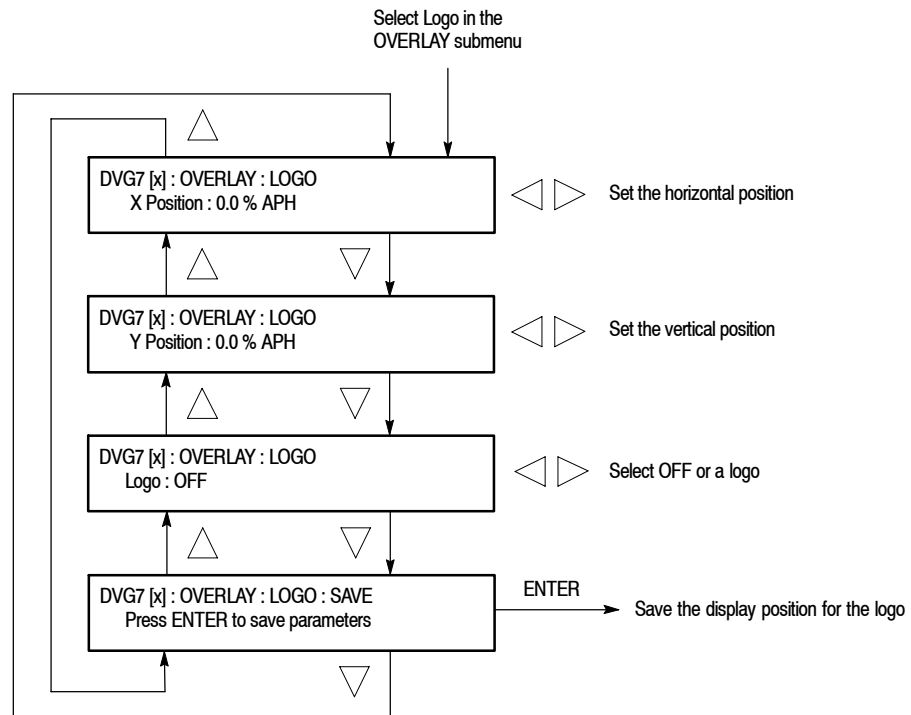

Figure 2-5: LOGO submenu

- **X Position:** Sets the horizontal position of the logo. The position is set as a percentage of active picture width. Use the left (◀) or right (▶) arrow button to change the position. You can set the value from -100.0 % to 0.0 % in 0.1% steps.
- **Y Position:** Sets the vertical position of the logo. The position is set as a percentage of active picture height. Use the left (◀) or right (▶) arrow button to change the position. You can set the value from -100.0 % to 0.0 % in 0.1% steps.
- **Logo:** Selects the logo you want to display. Use the left (◀) or right (▶) arrow button to select **OFF** or a logo file name. Press the **ENTER** button confirm the selection. When you select **OFF**, the logo overlay is disabled.
- **SAVE:** Saves the display position for the logo to the logo file. Press the **ENTER** button to save the current settings.

In order to display a logo using the LOGO submenu, you need to create the logo file (.lgo) and download it to the LOGO folder of the module.

Refer to the *TG700 TV Signal Generator Platform User Manual* for detailed information about how to create a logo file and download it to the TG700.

ID TEXT Submenu

This menu allows you to edit text that is overlaid on the output test signal, and to set the display position of the text. Use the up (▲) or down (▼) arrow button to scroll through the menu. Figure 2-6 shows the ID TEXT submenu.

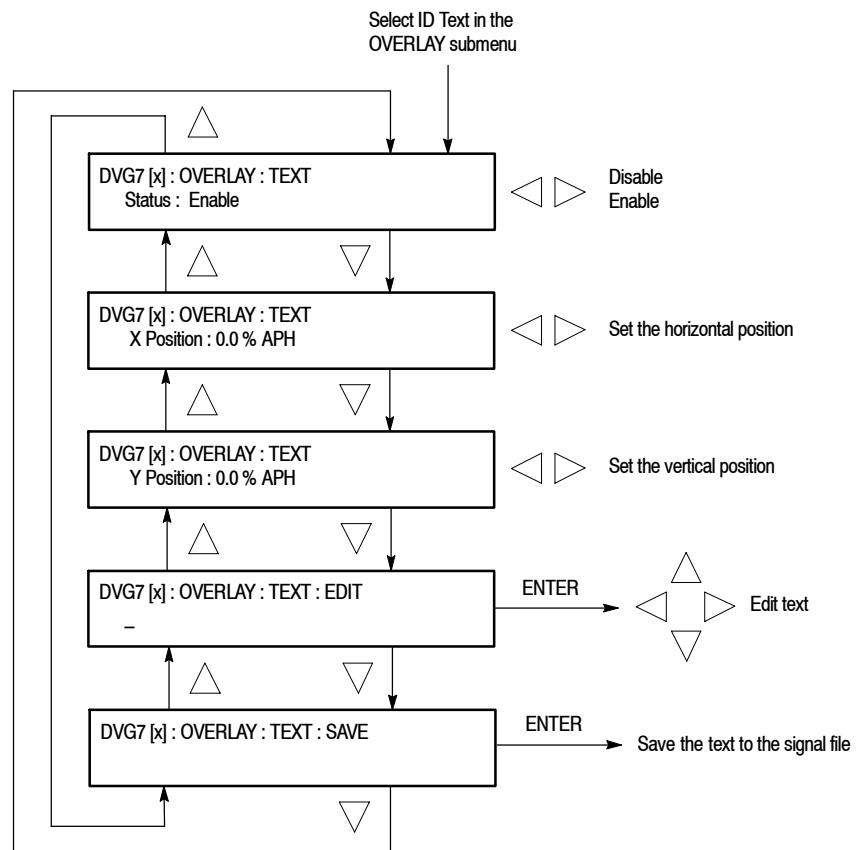

Figure 2-6: ID TEXT submenu

- **Status** : Enables or disables the text overlay. Use the left (◀) or right (▶) arrow button to select between **Enable** and **Disable**. Press the **ENTER** button to confirm the selection.
- **X Position**: Sets the horizontal position of the text. The position is set as a percentage of active picture width. Use the left (◀) or right (▶) arrow button to change the position. You can set the value from 0.0 % to 100.0 % in 1% steps.
- **Y Position**: Sets the vertical position of the text. The position is set as a percentage of active picture height. Use the left (◀) or right (▶) arrow button to change the position. You can set the value from 0.0 % to 100.0 % in 1% steps.
- **EDIT**: Edits the text you want to display on the output test signal.

To edit the text, first press the **ENTER** button to enable the text edit mode. Use the left (◀) or right (▶) arrow button to move the underscore character (_) to the character you want to change, and then use the up (▲) or down (▼) arrow button to select the desired character. When you enter all of the desired characters then press the **ENTER** button to end the text editing process. You can use up to 30 characters for the text. Use the blank character to erase an unneeded character(s).
- **SAVE**: Saves the text and its position to the signal file currently being output. Press the **ENTER** button to save the text and its position to the signal file.

CIRCLE Submenu

This menu allows you to create a circle overlaid on the output test signal and set its position on the display. Use the up (▲) or down (▼) arrow button to scroll through the menu. Figure 2-7 shows the CIRCLE submenu.

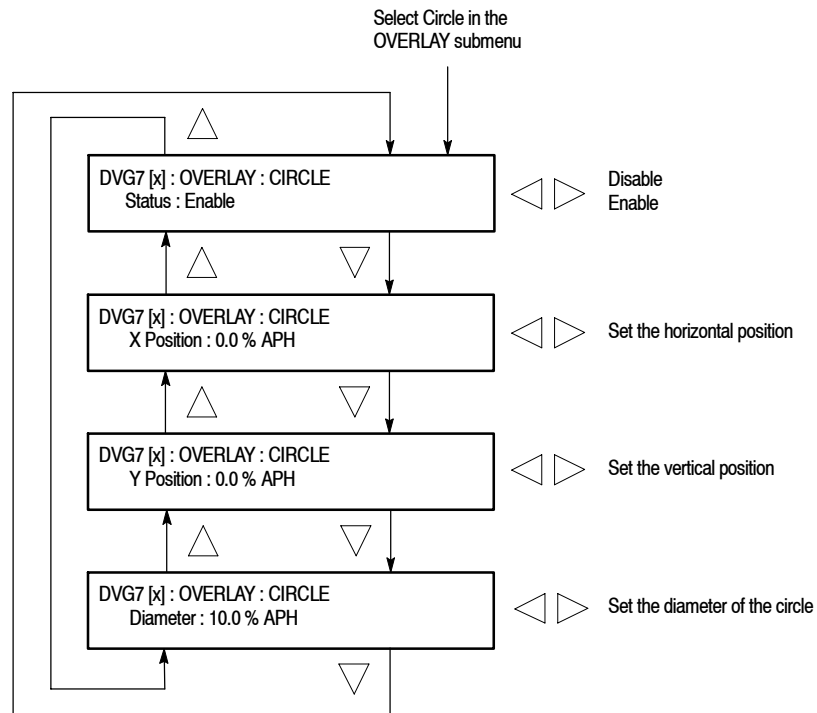

Figure 2-7: CIRCLE submenu

- **Status** : Enables or disables the circle overlay. Use the left (◀) or right (▶) arrow button to select between **Enable** and **Disable**. Press the **ENTER** button to confirm the selection.
- **X Position**: Sets the horizontal position of the circle. The position is set as a percentage of active picture width. Use the left (◀) or right (▶) arrow button to change the position. You can set the value from -50.0 % to 50.0 % in 1% steps.
- **Y Position**: Sets the vertical position of the circle. The position is set as a percentage of active picture height. Use the left (◀) or right (▶) arrow button to change the position. You can set the value from -50.0 % to 50.0 % in 1% steps.
- **Diameter**: Sets the diameter of the circle. The diameter is set as a percentage of active picture height. Use the left (◀) or right (▶) arrow button to change the value. You can set the value from 0.0 % to 100.0 % in 1% steps.

AUDIO GROUP Submenu

This menu allows you to enable or disable embedded audio of the selected audio group, select which audio channel to enable, and set the emphasis status bits, sampling alignment status bits, and sample bits of the selected audio group. Use the up (▲) or down (▼) arrow button to scroll through the menu. Figure 2-8 shows the AUDIO GROUP submenu.

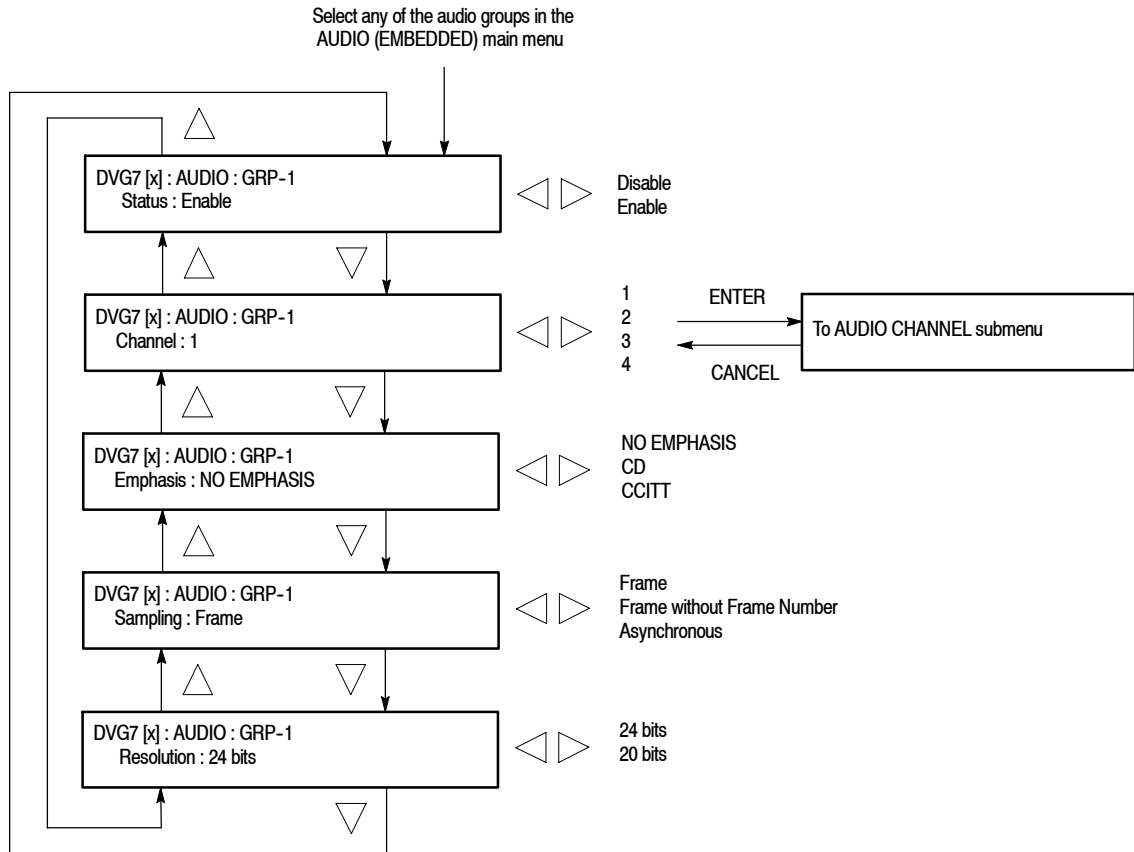

Figure 2-8: AUDIO GROUP submenu

- **Status** : Enables or disables the generation of embedded audio for the selected audio group. Use the left (◀) or right (▶) arrow button to select between **Enable** and **Disable**. Press the **ENTER** button to confirm the selection.
- **Channel**: Selects the channel where you will change the parameters. Use the left (◀) or right (▶) arrow button to select **1**, **2**, **3**, or **4**. When you select any of the channels and then press the **ENTER** button you access the **AUDIO CHANNEL** submenu. Refer to *AUDIO CHANNEL Submenu* on page 2-15 for detailed information.

- **Emphasis:** Sets the emphasis status bits for the selected audio group. Use the left (◀) or right (▶) arrow button to select **NO EMPHASIS**, **CD**, or **CCITT**. Press the **ENTER** button to confirm the selection.
- **Sampling:** Sets the sampling alignment status bits for the selected audio group. Use the left (◀) or right (▶) arrow button to select **Frame**, **Frame without Frame Number**, or **Asynchronous**. Press the **ENTER** button to confirm the selection.
- **Resolution:** Sets the resolution of the audio signal data for the selected audio group. Use the left (◀) or right (▶) arrow button to select between **24 bits** and **20 bits**. Press the **ENTER** button to confirm the selection.

AUDIO CHANNEL Submenu

This menu allows you to set the frequency, amplitude, and audio click of the embedded audio signal for the selected audio channel. Use the up (▲) or down (▼) arrow button to scroll through the menu. Figure 2-9 shows the AUDIO CHANNEL submenu.

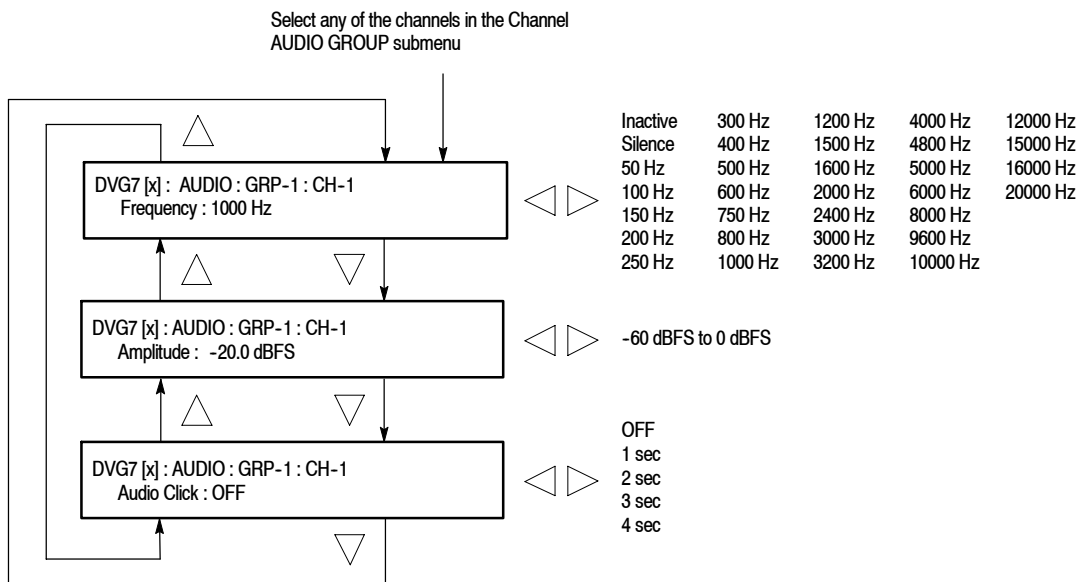

Figure 2-9: AUDIO CHANNEL submenu

- **Frequency** : Sets the audio signal frequency of the selected audio channel. Use the left (◀) or right (▶) arrow button to select the frequency. The selection items are as follows:

Inactive	400 Hz	1600 Hz	6000 Hz
Silence	500 Hz	2000 Hz	8000 Hz
50 Hz	600 Hz	2400 Hz	9600 Hz
100 Hz	750 Hz	3000 Hz	10000 Hz
150 Hz	800 Hz	3200 Hz	12000 Hz
200 Hz	1000 Hz	4000 Hz	15000 Hz
250 Hz	1200 Hz	4800 Hz	16000 Hz
300 Hz	1500 Hz	5000 Hz	20000 Hz

When **Inactive** is selected, the audio data output is disabled. Press the **ENTER** button to confirm the selection.

- **Amplitude** : Sets the audio signal amplitude of the selected audio channel. Use the left (◀) or right (▶) arrow button to set the amplitude. You can set the value from -60 dBFS to 0 dBFS in 1 dBFS steps.
- **Audio Click** : Inserts audio clicks in the selected audio channel. The audio tone, if any, is turned off for an interval around the audio click. Use the left (◀) or right (▶) arrow button to make the selection. The choices are **OFF**, **1 sec**, **2 sec**, **3 sec**, and **4 sec**. Press the **ENTER** button to enable the selection.

Audio Click becomes valid when you select **1 sec** to **4 sec** for the Audio Click rate. When Audio Click is valid, Audio Tone is turned off for 0.25 second around the click. For example, if you select **3 sec** for the click rate, the audio tone will be output for 2.75 seconds, and silent for 0.25 second; the click occurs during this silence. When Audio Click is **OFF**, the Audio Tone selected in the **FREQUENCY** menu is output continuously. Audio Click makes it easy to identify any channel(s) of the four output channels.

TIMING Submenu

This menu allows you to adjust the timing offset of the serial digital video outputs relative to the internal reference signal (frame reset signal). Use the up (▲) or down (▼) arrow button to change the menu items. Figure 2-10 shows the TIMING submenu.

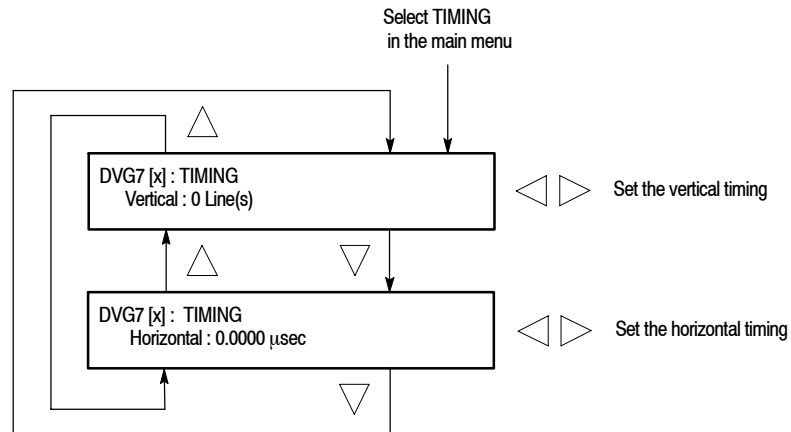

Figure 2- 10: TIMING submenu

- **Vertical:** Sets the vertical timing offset. Use the left (◀) or right (▶) arrow button to change the timing offset. You can set the value within 1/2 frame for 525-270 and 625-270 formats, and from -1 to +1 frame for 525-143 format in 1-line steps.
- **Horizontal:** Sets the horizontal timing offset. Use the left (◀) or right (▶) arrow button to change the timing offset. You can set the value from -1 to +1 line in 1-clock (37.0 ns for 525-270 and 625-270 formats, 69.8 ns for 525-143 format) steps.

NOTE. You can reset the timing offset to zero by pressing the left (◀) and right (▶) arrow buttons simultaneously.

VIDEO Submenu

This menu allows you to turn the Y, Pb, or Pr component of the serial digital video signals and the insertion of the EDH (Error Detection and Handling) on or off individually. You can also set the resolution of the serial digital video signals, and turn the output mode for an audio/video timing measurement. Use the up (▲) or down (▼) arrow button to scroll through the menu. Figure 2-11 shows the VIDEO submenu.

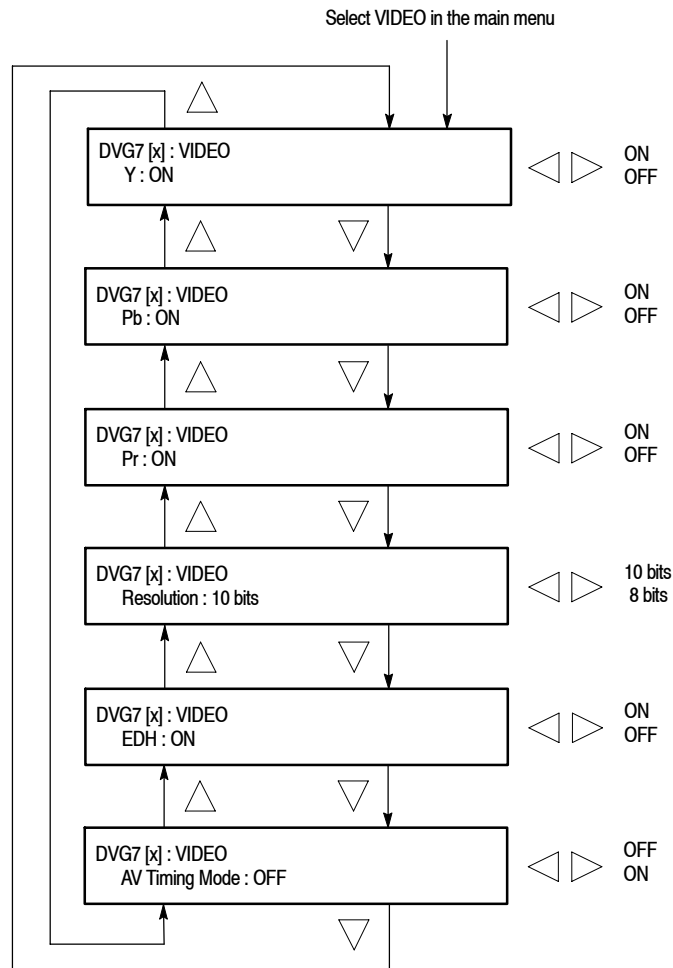

Figure 2- 11: VIDEO submenu

- **Y:** Turns the Y component of the serial digital video signals on or off. Use the left (◀) or right (▶) arrow button to select between **ON** and **OFF**. Press the **ENTER** button to confirm the selection.
- **Pb:** Turns the Pb component of the serial digital video signals on or off. Use the left (◀) or right (▶) arrow button to select between **ON** and **OFF**. Press the **ENTER** button to confirm the selection.

- **Pr:** Turns the Pr component of the serial digital video signals on or off. Use the left (◀) or right (▶) arrow button to select between **ON** and **OFF**. Press the **ENTER** button to confirm the selection.
- **Resolution:** Sets the resolution of the serial digital video signals. Use the left (◀) or right (▶) arrow button to select between **10 bits** and **8 bits**. Press the **ENTER** button to confirm the selection.
- **EDH:** Turns the insertion of the EDH (Error Detection and Handling) information on or off on the serial digital video signals. Use the left (◀) or right (▶) arrow button to select between **ON** and **OFF**. Press the **ENTER** button to confirm the selection.
- **AV Timing Mode:** Turns the output mode for an audio/video timing measurement on or off. Use the left (◀) or right (▶) arrow button to select between **ON** and **OFF**. Press the **ENTER** button to confirm the selection.

When you turn on this mode, the specified audio and video signals are synchronously on for 0.5 second and off for 4.5 seconds. With this signal, you can measure the time delay that accumulates between the audio and video content of the television signal during signal transport. The time delay can be measured by a video analyzer with the serial digital video signal or by an oscilloscope with the analog audio and video signals deembedded from the serial digital video signal. The following settings are recommended for the audio and video signals when you use this mode:

Audio signal (CH1 and CH2 of Group 1) : 10000 Hz, -20 dBFS
Video signal: 100% Flat Field

NOTE. *The AV Timing Mode setting is not saved as a preset.*

**BLACK Submenu
(Option BK Only)**

This menu allows you to set the output parameters of the serial digital black signals output from the **BLACK1** and **BLACK 2** connectors. Use the up (▲) or down (▼) arrow button to change the menu items. Figure 2-12 shows the BLACK submenu.

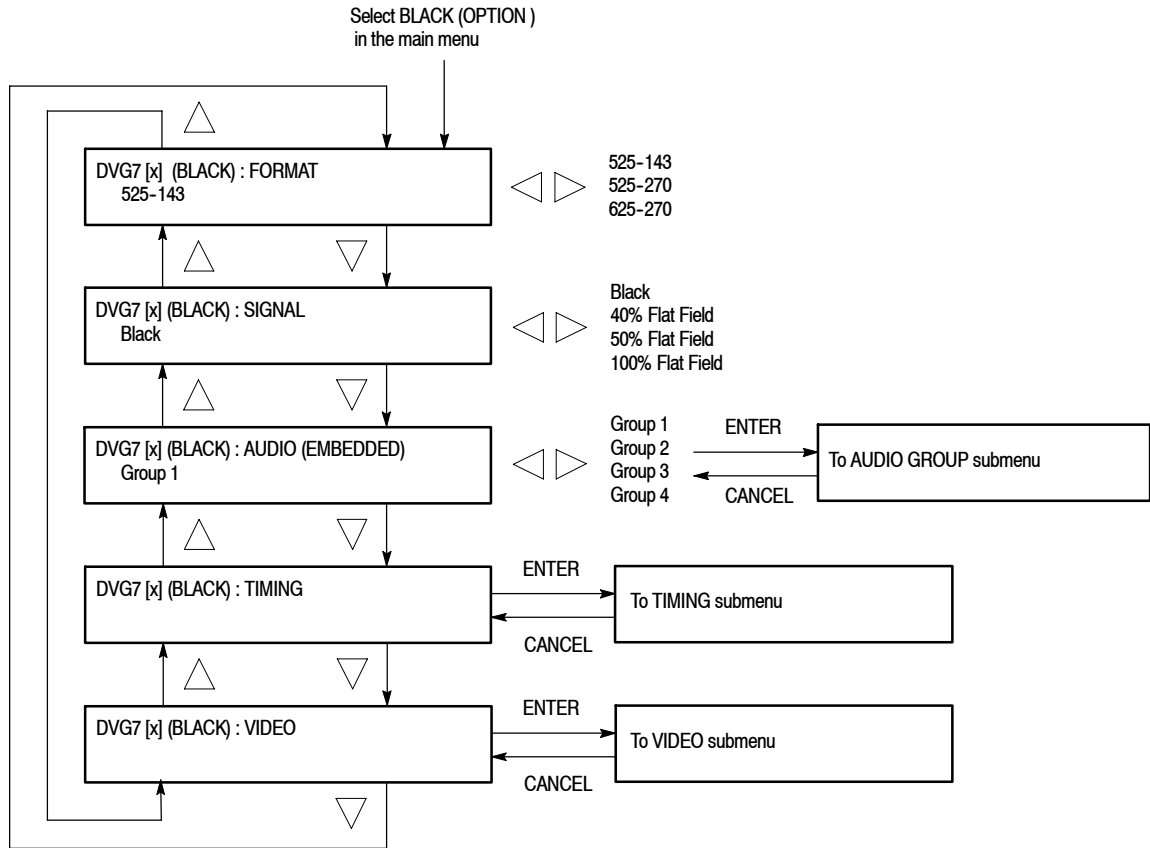

Figure 2- 12: BLACK submenu (Option BK only)

FORMAT. Selects the format of the output serial digital black signals. Use the left (◀) or right (▶) arrow button to select **525-143**, **525-270**, or **625-270**. Press the **ENTER** button to confirm the selection.

SIGNAL. Selects the serial digital black signal to output. Use the left (◀) or right (▶) arrow button to select between **Black** (serial digital black), **40% Flat Field**, **50% Flat Field**, and **100% Flat Field**. Press the **ENTER** button to confirm the selection.

AUDIO (EMBEDDED). Sets the parameters for embedded audio on the serial digital black signals. Use the left (◀) or right (▶) arrow button to select **Group 1**, **Group 2**, **Group 3**, or **Group 4**. When you select any of the groups and then press the **ENTER** button, you will access the **AUDIO GROUP** submenu. Refer to *AUDIO GROUP Submenu* on page 2-14 for detailed information.

TIMING. Sets the timing offset of the serial digital black outputs relative to the internal reference signal (frame reset signal). When you select this menu item and then press the **ENTER** button, you will access the **TIMING** submenu. Refer to *TIMING Submenu* on page 2-17 for detailed information.

VIDEO. Sets the resolution and EDH insertion of the serial digital black signals. When you select this menu item and then press the **ENTER** button, you will access the **VIDEO** submenu. Refer to the *VIDEO Submenu* on page 2-18 for detailed information.

Rear-Panel Connectors

The DVG7 Generator module is equipped with two connectors, **SIGNAL 1** and **SIGNAL 2** which will output serial digital test signals. If Option BK is installed there will be two additional connectors, **BLACK 1** and **BLACK 2**, which will output serial digital black signals. Figure 2-13 shows the DVG7 Generator module with all four connectors installed (Option BK).

NOTE. The *SIGNAL 1* and *SIGNAL 2* connectors will both output the same test signal, and the *BLACK 1* and *BLACK 2* connectors will both output the same black signal.

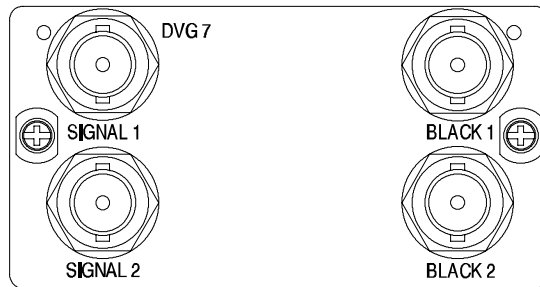

Figure 2- 13: DVG7 module rear-panel connectors (Option BK)

- **SIGNAL 1:** Serial digital test signal output.
- **SIGNAL 2:** Serial digital test signal output.
- **BLACK 1:** Serial digital black output (Option BK only).
- **BLACK 2:** Serial digital black output (Option BK only).

Factory Default Settings

Table 2-2 shows the factory default settings for the DVG7 Generator module. These settings are recalled when you select **Factory Default** from the **PRESET : RECALL** menu item in the mainframe main menu.

Table 2-2: Factory default settings

Menu item name	Settings
STATUS	525-270 SMPTE Color Bars
MOVING PICTURE	
H Step	0 Sample(s)
V Step	0 Line(s)
Period	1 Frame(s)
Random	Disable
OVERLAY : OBJECT	Logo
OVERLAY : BLINK	OFF
OVERLAY : LOGO	
Logo	OFF
OVERLAY : ID TEXT	
Status	Disable
OVERLAY : CIRCLE	
Status	Disable
X Position	0.0 % APH
Y Position	0.0 % APH
Diameter	90 % APH
AUDIO : GRP-1 to GRP-4	
Status	Disable
Emphasis	No Emphasis
Sampling	Frame
Resolution	20 bits
AUDIO : GRP-1 : Ch-1 to CH-4	
Frequency	1000 Hz
Amplitude	-20.0 dBFS
Audio Click	OFF
TIMING	
Vertical	0 Line(s)
Horizontal	0.0000 μ s

Table 2-2: Factory default settings (Cont.)

Menu item name	Settings
VIDEO	
Y	ON
Pb	ON
Pr	ON
Resolution	10 bits
EDH	ON
AV Timing Mode	OFF
Option BK	
(BLACK) FORMAT	525-270
(BLACK) SIGNAL	Black
(BLACK) AUDIO : GRP-1 to GRP-4	
Status	Disable
Emphasis	No Emphasis
Sampling	Frame
Resolution	20 bits
(BLACK) AUDIO : CH-1 to CH-4	
Frequency	1000 Hz
Amplitude	-20.0 dBFS
Audio Click	OFF
(BLACK)TIMING	
Vertical	0 Line(s)
Horizontal	0.0000 μ s
(BLACK)VIDEO	
Resolution	10 bits
EDH	ON



Reference

Syntax

This section contains information on the Standard Commands for Programmable Instruments (SCPI) and the programming structure you can use to program your DVG7 Generator module.

Programming Model

Specific conditions must exist before programming commands will affect the test signal generated by a module.

Selecting the Module

Select the module using the `:INSTRument:SElect` command before executing any commands. Many of the commands used by the DVG7 module are shared by several modules and will be accepted without a reported error.

Command Arguments

Many commands will accept either string or numeric arguments. For example: a boolean argument can either be "1" or "ON".

Signal parameter commands that have a `:STEP` node can accept either a numeric value or they can accept a string argument that refers to the `:STEP` increment.

Signal parameter commands with a `:STEP` node will accept the following strings in addition to a numeric value:

UP. Use this argument to increase the parameter value one increment as defined by the `:STEP` value.

DOWN. Use this argument to decrease the parameter value one increment as defined by the `:STEP` value.

MINimum. Use this argument to set the parameter value to the minimum acceptable value.

MAXimum. Use this argument to set the parameter value to the maximum acceptable value.

DEFault. Use this argument to set the parameter value to the default value.

Query Arguments

If you send a query with no argument, the response is the current value. You can also use **MINimum**, **MAXimum**, and **DEFault** as arguments for queries whose command form can use these arguments (refer to the command syntax for the specific command). Instead of returning the current value, queries using these arguments return the following information:

MINimum. Return the minimum acceptable value.

MAXimum. Return the maximum acceptable value.

DEFault. Return the default value.

Argument Example

The following example demonstrates the effect of each of the arguments when used with a step value.

1. `:INSTRument:SElect "DVG7:#"` selects the digital video generator module located in the slot number indicated by the “#” symbol.
2. `:OUTPut:CIRClE:STATe ON` displays a circle on the video display.

NOTE. `:OUTPut:CIRClE:DIAMeter` uses an argument that is the percent of picture height.

3. `:OUTPut:CIRClE:DIAMeter DEFaul t` sets the circle diameter to 90 percent of the screen height.
4. `:OUTPut:CIRClE:DIAMeter:STEP 10` sets the step increment to 10 percent.
5. `:OUTPut:CIRClE:DIAMeter DOWN` changes the circle diameter to 80 percent of the screen height.
6. `:OUTPut:CIRClE:DIAMeter 50` changes the circle diameter to 50 percent of the screen height.
7. `:OUTPut:CIRClE:DIAMeter MAXimum` changes the circle diameter to 100 percent of the screen height.
8. `:OUTPut:CIRClE:DIAMeter MINimum` changes the circle diameter to 0 percent of the screen height.
9. `:OUTPut:CIRClE:DIAMeter UP` changes the circle diameter to 10 percent of the screen height.
10. `:OUTPut:CIRClE:DIAMeter? MAXimum` queries the maximum circle diameter (not the current diameter). The query returns the value of 100 percent, which is the maximum circle diameter allowable.

SCPI Commands and Queries

SCPI is a standard created by a consortium that provides guidelines for remote programming of instruments. These guidelines provide a consistent programming environment for instrument control and data transfer. This environment uses defined programming messages, instrument responses, and data format across all SCPI instruments, regardless of manufacturer. The DVG7 Generator module uses a command language based on the SCPI standard.

The SCPI language is based on a hierarchical or tree structure (see Figure 3-1) that represents a subsystem. The top level of the tree is the root node; it is followed by one or more lower-level nodes.

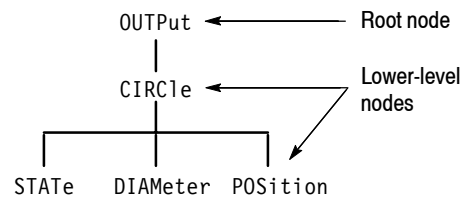

Figure 3-1: Example of SCPI subsystem hierarchy

You can create commands and queries from these subsystem hierarchy trees. Commands specify actions for the instrument to perform. Queries return measurement data and information about parameter settings.

For more information on SCPI commands and programming structure, refer to the *TG700 Signal Generator Platform User Manual*.

Remote Commands

This section describes the remote commands used to control the DVG7 Generator module remotely. The commands to the module are divided into the following three groups:

- MASS MEMORY commands (Refer to the *TG700 TV Signal Generator Platform User Manual*)
- OUTPUT commands
- SENSE commands

MASS MEMORY Commands

Two MASS MEMORY commands are listed here for your reference. You can use these to load and query the output test signal. Detailed information for using these commands are located in the *TG700 TV Signal Generator Platform User Manual*.

```
:MMEmory:LOAD:SIGNa1 <module_name>,<signal_name>  
:MMEmory:LOAD:SIGNa1 <slot_number>,<signal_name>
```

Loads a signal into the specified module.

```
:MMEmory:SIGNa1:ACTive? <slot_number>|<module_name>
```

Returns the current output signal of the specified module.

OUTPUT Commands

Use these commands to control the output parameters of the module. These include embedded audio and circle/text/logo overlay.

Command Tree

```

:OUTPut<n>
  :CIRClE
    :STATe          ON|OFF
    :DIAMeter       <numeric_value>
    :POSition
      :HORizontal  <numeric_value>
      :VERTical    <numeric_value>
  :EAUDio
    :CHANnel<n>
      :AMPLitude   <numeric_value>
      :FREQuency   <numeric_value>
      :CLICK       OFF|1|2|3|4
    :GROup<n>
      :STATe       ON|OFF
      :PREemphasIs OFF|CD|CCITt
      :NBITS       20|24
      :SAMPLIng    FRAME|NOFRame|ASYNc
  :LOGO
    :STATe          ON|OFF
    :POSition
      :HORizontal  <numeric_value>
      :VERTical    <numeric_value>
    :SElect         <logo_name>
    :SAVE
  :MOVE
    :HORizontal    <numeric_value>
    :VERTical      <numeric_value>
    :PERiod        <numeric_value>
    :RANDom[:STATe] ON|OFF
  :OVERlay
    :BLINK
      :STATe       ON|OFF
      :PERiod      <numeric_value>
  :TEXT
    :STATe         ON|OFF
    :DATA          <string>
    :POSition
      :HORizontal  <numeric_value>
      :VERTical    <numeric_value>
    :SAVE

```

```

:VIDeo
:Y
  :STATe          ON|OFF
:PB
  :STATe          ON|OFF
:PR
  :STATe          ON|OFF
:NBITS
:EDH
  :STATe          ON|OFF
:AVTiming
  :STATe          ON|OFF
:STANdard         D2_NTSC|D1_NTSC|D1_PAL
:SIGNal          BLACK|GRAY|FF50P|WHITE

```

Command Description

```
:OUTPut1:CIRClE:STATe ON|OFF
```

Turns the circle overlay on the video signal on or off. You can use 1 or 0 instead of ON or OFF.

```
:OUTPut1:CIRClE:STATe?
```

Returns the current circle overlay state.

```
:OUTPut1:CIRClE:DIAMeter <numeric_value>
```

Sets the diameter of the displayed circle. The unit is percent of active picture height. You can set the diameter from 0 % to 100 % in 1 % steps. You can also use MIN, MAX, or DEF instead of a numeric value.

```
:OUTPut1:CIRClE:DIAMeter?
```

Returns the diameter of the displayed circle.

```
:OUTPut1:CIRClE:POSition:HORizontal <numeric_value>
```

Sets the horizontal position of the circle as it appears on the active signal. The unit is percent of active picture width. You can set the position from -50 % to +50 % in 1 % steps. You can also use MIN, MAX, or DEF instead of a numeric value.

```
:OUTPut1:CIRClE:POSition:HORizontal?
```

Returns the current horizontal position of the circle as it appears on the active signal.

`:OUTPut1:CIRClE:POSition:VERTical <numeric_value>`

Sets the vertical position of the circle as it appears on the active signal. The unit is percent of active picture height. You can set the position from -50 % to +50 % in 1 % steps. You can also use MIN, MAX, or DEF instead of a numeric value.

`:OUTPut1:CIRClE:POSition:VERTical?`

Returns the current vertical position of the circle as it appears on the active signal.

`:OUTPut<n>:EAUDio:CHANnel<m>:AMPLitude <numeric_value>`

Sets the amplitude of a specific embedded audio channel for the selected outputs. You can set the amplitude from -60 dBFS to 0 dBFS in 1 dBFS steps. The <n> in the command represents the output connector type. "1" represents the SIGNAL connectors and "2" represents the optional BLACK connectors. The <m> in the command represents the channel number and you can use any channel number from 1 through 16.

`:OUTPut<n>:EAUDio:CHANnel<m>:AMPLitude?`

Returns the current amplitude of a specific embedded audio channel for the selected outputs. The <n> in the command represents the output connector type. "1" represents the SIGNAL connectors and "2" represents the optional BLACK connectors. The <m> in the command represents the channel number and you can use any channel number from 1 through 16.

`:OUTPut<n>:EAUDio:CHANnel<m>:FREQuency <numeric_value>`

Sets the frequency of a specific embedded audio channel for the selected outputs. The frequency choices are -1, 0, 50, 100, 150, 200, 250, 300, 400, 500, 600, 750, 800, 1000, 1200, 1500, 1600, 2000, 2400, 3000, 3200, 4000, 4800, 5000, 6000, 8000, 9600, 10000, 12000, 15000, 16000, or 20000. For -1, the output of the audio data is disabled. The <n> in the command represents the output connector type. "1" represents the SIGNAL connectors and "2" represents the optional BLACK connectors. The <m> in the command represents the channel number and you can use any channel number from 1 through 16.

:OUTPut<n>:EAUDio:CHANnel<m>:FREQuency?

Returns the current frequency of a specific embedded audio channel for the selected outputs. The <n> in the command represents the output connector type. “1” represents the SIGNAL connectors and “2” represents the optional BLACK connectors. The <m> in the command represents the channel number and you can use any channel number from 1 through 16.

:OUTPut<n>:EAUDio:CHANnel<m>:CLICk 0|1|2|3|4

Sets the audio click of a specific audio channel for the selected outputs. You can select 0, 1 (second), 2 (seconds), 3 (seconds) or 4 (seconds). When 1, 2, 3 or 4 is selected, the audio click becomes valid. Audio Tone is turned off for 0.25 seconds around the time of the click. The <n> in the command represents the output connector type. “1” represents the SIGNAL connectors and “2” represents the optional BLACK connectors. The <m> in the command represents the channel number and you can use any channel number from 1 through 16.

:OUTPut<n>:EAUDio:CHANnel<m>:CLICk?

Returns the current audio click settings of a specific audio channel for the selected outputs. The <n> in the command represents the output connector type. “1” represents the SIGNAL connectors and “2” represents the optional BLACK connectors. The <m> in the command represents the channel number and you can use any channel number from 1 through 16.

:OUTPut<n>:EAUDio:GRoup<m>:STATe ON|OFF

Turns on or off the output of a specific audio group for the selected outputs. You can also use 1 or 0 instead of ON or OFF. The <n> in the command represents the output connector type. “1” represents the SIGNAL connectors and “2” represents the optional BLACK connectors. The <m> in the command represents the group number and you can use any channel number from 1 through 4.

:OUTPut<n>:EAUDio:GRoup<m>:STATe?

Returns the current output state of a specific audio group for the selected outputs. The <n> in the command represents the output connector type. “1” represents the SIGNAL connectors and “2” represents the optional BLACK connectors. The <m> in the command represents the group number and you can use any channel number from 1 through 4.

`:OUTPut<n>:EAUDio:GROup<m>:PREEmphasis OFF|CD|CCITt`

Turns the preemphasis bits in the audio signal of a specific embedded audio group for the selected outputs on or off. The signal itself does not have preemphasis, but you can set the bits in order to check other equipment. The <n> in the command represents the output connector type. “1” represents the SIGNAL connectors and “2” represents the optional BLACK connectors. The <m> in the command represents the group number and you can use any channel number from 1 through 4.

`:OUTPut<n>:EAUDio:GROup<m>:PREEmphasis?`

Returns the current preemphasis bits settings of a specific embedded audio group for the selected outputs. The <n> in the command represents the output connector type. “1” represents the SIGNAL connectors and “2” represents the optional BLACK connectors. The <m> in the command represents the group number and you can use any channel number from 1 through 4.

`:OUTPut<n>:EAUDio:GROup<m>:NBITs 20|24`

Sets the sample bits of a specific embedded audio group for the selected outputs. The <n> in the command represents the output connector type. “1” represents the SIGNAL connectors and “2” represents the optional BLACK connectors. The <m> in the command represents the group number and you can use any channel number from 1 through 4.

`:OUTPut<n>:EAUDio:GROup<m>:NBITs?`

Returns the current sample bits of a specific embedded audio group for the selected outputs. The <n> in the command represents the output connector type. “1” represents the SIGNAL connectors and “2” represents the optional BLACK connectors. The <m> in the command represents the group number and you can use any channel number from 1 through 4.

`:OUTPut<n>:EAUDio:GROup<m>:SAMPLIng FRAME|NOFRame|ASYNc`

Sets the sampling alignment status bits in the audio signal of a specific embedded audio group for the selected outputs. The <n> in the command represents the output connector type. “1” represents the SIGNAL connectors and “2” represents the optional BLACK connectors. The <m> in the command represents the group number and you can use any channel number from 1 through 4.

:OUTPut<n>:EAUDio:GROup<m>:SAMPLIng?

Returns the current sampling alignment status bits settings of a specific embedded audio group for the selected outputs. The <n> in the command represents the output connector type. “1” represents the SIGNAL connectors and “2” represents the optional BLACK connectors. The <m> in the command represents the group number and you can use any channel number from 1 through 4.

:OUTPut1:LOGO:STATe ON|OFF

Turns the logo overlay display on the video signal on or off. You can also use 1 or 0 instead of ON or OFF.

:OUTPut1:LOGO:STATe?

Returns the current logo overlay state.

:OUTPut1:LOGO:POSition:HORizontal <numeric_value>

Sets the horizontal position of the logo as it appears on the active signal. The unit is percent of active picture width. You can set the position from -100 % to 0 % in 0.1 % steps. You can also use MIN, MAX, or DEF instead of a numeric value.

:OUTPut1:LOGO:POSition:HORizontal?

Returns the current horizontal position of the logo.

:OUTPut1:LOGO:POSition:VERTical <numeric_value>

Sets the vertical position of the logo as it appears on the active signal. The unit is percent of active picture height. You can set the position from -100 % to 0 % in 0.1 % steps. You can also use MIN, MAX, or DEF instead of a numeric value.

:OUTPut1:LOGO:POSition:VERTical?

Returns the current vertical position of the logo.

:OUTPut1:LOGO:SElect <logo_name>

Selects the logo used for the logo overlay.

:OUTPut1:LOGO:SElect?

Returns the current logo used for the logo overlay.

:OUTPut1:LOGO:SAVe

Saves the current display position of the logo to the logo file. There are no arguments.

`:OUTPut1:MOVe:HORizontal <numeric_value>`

Sets the amount of horizontal scrolling in the moving picture mode. You can set the value from -252 to +252 in 4 samples steps.

`:OUTPut1:MOVe:HORizontal?`

Returns the amount of horizontal scrolling in the moving picture mode.

`:OUTPut1:MOVe:VERTical <numeric_value>`

Sets the amount of vertical scrolling in the moving picture mode. You can set the value from -252 to +252 in 1 line steps.

`:OUTPut1:MOVe:VERTical?`

Returns the amount of vertical scrolling in the moving picture mode.

`:OUTPut1:MOVe:PERiod <numeric_value>`

Sets the time interval between occurrences of the scrolling. You can set the value from 1 to 16 in 1 field steps.

`:OUTPut1:MOVe:PERiod?`

Returns the time interval between occurrences of the scrolling.

`:OUTPut1:MOVe:RANDom:STATe ON|OFF`

Turns the random scrolling mode on or off. You can also use 1 or 0 instead of ON or OFF.

`:OUTPut1:MOVe:RANDom:STATe?`

Returns the current state of the random scrolling mode.

`:OUTPut1:OVERlay:BLINK:STATe ON|OFF`

Turns on or off the blinking mode for the logo, text, and circle overlay. You can also use 1 or 0 instead of ON or OFF

`:OUTPut1:OVERlay:BLINK:STATe?`

Returns the current state of the blinking mode for the logo, text, and circle overlay.

`:OUTPut1:OVERlay:BLINK:PERiod <numeric_value>`

Sets the blinking interval of the blinking mode for the logo, text, and circle overlay. You can set the value as 0.5 seconds or 1.0 seconds.

:OUTPut1:OVERlay:BLINK:PERiod?

Returns the blinking interval of the blinking mode for the logo, text, and circle overlay.

:OUTPut1:TEXT:STATe ON|OFF

Turns the text overlay display on the video signal on or off. You can also use 1 or 0 instead of ON or OFF.

:OUTPut1:TEXT:STATe?

Returns the current text overlay state.

:OUTPut1:TEXT:DATA <string>

Sets the current string for the text mode.

:OUTPut1:TEXT:DATA?

Returns the current string for the text mode.

:OUTPut1:TEXT:POSition:HORizontal <numeric_value>

Sets the text horizontal position in the video signal. The unit is percent of active picture width. You can set the position from 0 % to 100 % in 1 % steps. You can also use MIN, MAX, or DEF instead of the numeric value.

:OUTPut1:TEXT:POSition:HORizontal?

Returns the current text horizontal position in the video signal.

:OUTPut1:TEXT:POSition:VERTical <numeric_value>

Sets the text vertical position in the video signal. The unit is percent of active picture height. You can set the position from 0 % to 100 % in 1 % steps. You can also use MIN, MAX, or DEF instead of the numeric value.

:OUTPut1:TEXT:POSition:VERTical?

Returns the current text vertical position in the video signal.

:OUTPut1:TEXT:SAVe

Saves the current text and its display position to the signal file. There are no arguments.

:OUTPut1:VIDeo:Y:STATe ON|OFF

Turns the Y component of the serial digital video signals on or off. You can also use 1 or 0 instead of ON or OFF.

:OUTPut1:VIDeo:Y:STATe?

Returns the current output state of the Y component of the serial digital video signals.

:OUTPut1:VIDeo:PB:STATe ON|OFF

Turns the P_B component of the serial digital video signals on or off. You can also use 1 or 0 instead of ON or OFF.

:OUTPut1:VIDeo:PB:STATe?

Returns the current output state of the P_B component of the serial digital video signals.

:OUTPut1:VIDeo:PR:STATe ON|OFF

Turns the P_R component of the serial digital video signals on or off. You can also use 1 or 0 instead of ON or OFF.

:OUTPut1:VIDeo:PR:STATe?

Returns the current output state of the P_R component of the serial digital video signals.

:OUTPut<n>:VIDeo:NBITs 8|10

Sets the video resolution for the selected output. The options are 8 bits or 10 bits. The <n> in the command represents the output connector type. “1” represents the SIGNAL connectors and “2” represents the optional BLACK connectors.

:OUTPut<n>:VIDeo:NBITs?

Returns the current video resolution for the selected outputs. The options are 8 bits or 10 bits. The <n> in the command represents the output connector type. “1” represents the SIGNAL connectors and “2” represents the optional BLACK connectors.

:OUTPut<n>:VIDeo:EDH:STATe ON|OFF

Turns Error Detection and Handling insertion for the selected outputs on or off. The <n> in the command represents the output connector type. “1” represents the SIGNAL connectors and “2” represents the optional BLACK connectors.

:OUTPut1:VIDeo:EDH:STATe?

Returns the current Error Detection and Handling insertion status.

:OUTPut<n>:VIDeo:EDH:STATe?

Returns the current Error Detection and Handling insertion status for the selected outputs. The <n> in the command represents the output connector type. “1” represents the SIGNAL connectors and “2” represents the optional BLACK connectors.

:OUTPut1:VIDeo:AVTiming:STATe ON|OFF

Turns the output mode for an audio/video timing measurement on or off. Refer to *Operating Basics* for detailed information about the mode. You can also use 1 or 0 instead of ON or OFF.

:OUTPut1:VIDeo:AVTiming:STATe?

Returns the current output mode setting for an audio/video timing measurement.

:OUTPut2:STANdard D2_NTSC|D1_NTSC|D1_PAL

Sets the video standard for the serial digital black signals output from the BLACK connectors. The choices are D2_NTSC (525-143 format), D1_NTSC (525-270 format), or D1_PAL (625-270 format). This command is only available if Option BK is installed.

:OUTPut<n>:STANdard?

Returns the video standard for the selected output. The <n> in the command represents the output connector type. “1” represents the SIGNAL connectors and “2” represents the optional BLACK connectors.

:OUTPut2:SIGNa1 BLACK|GRAY|FF50P|WHITE

Sets the type of the serial digital black signals output from the BLACK connectors. The options are BLACK (serial digital black signal), GRAY (40% flat field signal), FF50P (50% flat field signal), or WHITE (100% flat field signal). This command is only available if Option BK is installed.

:OUTPut2:SIGNa1?

Returns the current serial digital black signals output from the BLACK connectors. This command is only available if Option BK is installed.

:OUTPut:CONFIgure?

Returns the availability of serial digital black signal output option (Option BK). “1” indicates that the option is available and “0” indicates that the option is not available.

SENSE Commands

Use these commands to set the timing offset of the SIGNAL outputs and the BLACK outputs (Option BK only) relative to the internal reference signal (frame reset signal).

Refer to *Operating Basics* for detailed information about the setting range.

Command Tree

```
:SENSe<n>
  :CORRection
    :MDElay
      :HORizontal <numeric_value>
        :STEP <numeric_value>
      :VERTical <numeric_value>
        :STEP <numeric_value>
```

Command Description

`:SENSe<n>:CORRection:MDElay:HORizontal <numeric_value>`

Sets the horizontal timing offset of the selected outputs. The timing resolution is clock-cycles. The units are microseconds. You can use UP, DOWN, or DEF instead of the numeric value. If the argument exceeds the horizontal time value, then the vertical offset is adjusted to accommodate the requested delay. The <n> in the command represents the type of output connector. “1” represents the SIGNAL connectors and “2” represents the BLACK connectors.

`:SENSe<n>:CORRection:MDElay:HORizontal?`

Returns the current horizontal timing offset of the selected outputs. The <n> in the command represents the type of output connector. “1” represents the SIGNAL connectors and “2” represents the BLACK connectors.

`:SENSe<n>:CORRection:MDElay:HORizontal:STEP <numeric_value>`

Sets the step increment used by the UP or DOWN commands. The units are microseconds. You can use MIN, MAX, or DEF instead of a numeric value. The <n> in the command represents the type of output connector. “1” represents the SIGNAL connectors and “2” represents the BLACK connectors.

:SENSe<n>:CORRection:MDELay:HORizontal:STEP?

Returns the current step increment. The <n> in the command represents the type of output connector. “1” represents the SIGNAL connectors and “2” represents the BLACK connectors.

:SENSe<n>:CORRection:MDELay:VERTical <numeric_value>

Sets the vertical timing offset of the selected outputs. The argument can be a floating point value that is translated into integer lines with a horizontal offset. You can use UP, DOWN, or DEF instead of a numeric value. The <n> in the command represents the type of output connector. “1” represents the SIGNAL connectors and “2” represents the BLACK connectors.

:SENSe<n>:CORRection:MDELay:VERTical?

Returns the current vertical timing offset of the selected outputs. The <n> in the command represents the type of output connector. “1” represents the SIGNAL connectors and “2” represents the BLACK connectors.

:SENSe<n>:CORRection:MDELay:VERTical:STEP <numeric_value>

Sets the step increment used by the UP or DOWN commands. You can use MIN, MAX, or DEF instead of a numeric value. The <n> in the command represents the type of output connector. “1” represents the SIGNAL connectors and “2” represents the BLACK connectors.

:SENSe<n>:CORRection:MDELay:VERTical:STEP?

Returns the current step increment. The <n> in the command represents the type of output connector. “1” represents the SIGNAL connectors and “2” represents the BLACK connectors.



Appendices

Appendix A: Specifications

Tables A-1 through A-4 list the electrical and environmental characteristics of the DVG7 Generator module.

Electrical Characteristics

Table A- 1: Serial digital video signal outputs

Characteristic	Performance requirements	Reference information
Connector	BNC	
Number of output	2	SIGNAL 1 and SIGNAL 2
Bit Rate	143 Mbps 270 Mbps	
Signal amplitude, typical	800 mV \pm 10%	
Rise and fall times, typical	0.4 ns to 1.5 ns	20% to 80%
Jitter, typical	\leq 0.2 UIp-p	For all jitter frequencies above 10 Hz.
Return loss	$>$ 15 dB	5 MHz to 270 MHz

Table A- 2: Serial digital black signal outputs (Option BK only)

Characteristic	Performance requirements	Reference information
Connector	BNC	
Number of output	2	BLACK 1 and BLACK 2
Bit Rate	143 Mbps 270 Mbps	
Signal amplitude, typical	800 mV \pm 10%	
Rise and fall times, typical	0.4 ns to 1.5 ns	20% to 80%
Jitter, typical	\leq 0.2 UIp-p	For all jitter frequencies above 10 Hz.
Return loss	$>$ 15 dB	5 MHz to 270 MHz

Table A-3: Embedded audio

Characteristic	Performance requirements	Reference information
Number of channels	16 channels in 4 groups; 8 AES/EBU audio pairs	
Audio tones		
Frequency	Silence to 20 kHz; 31 discrete settings	
Level	-60 to 0 dBFS in 1 dB steps	
Pre-emphasis		Emphasis status bits can be inserted.

Environmental Characteristics

Table A-4: Environmental characteristics

Characteristic	Description
Temperature	
Operating	0 °C to +50 °C
Non-operating	-20 °C to +60 °C
Relative Humidity	
Operating	20% to 80% (No condensation); Maximum wet-bulb temperature 29.4° C
Non-operating	5% to 90% (No condensation); Maximum wet-bulb temperature 40.0° C
Altitude	
Operating	To 4.5 km (15,000 feet) Maximum operating temperature decreases 1 °C each 300 m above 1.5 km.
Non-operating	To 15 km (50,000 feet)
Vibration	
Operating	3.04 m/s ² (0.31 G _{rms}), 5 Hz to 500 Hz, 10 min, three axes
Non-operating	23.3 m/s ² (2.38 G _{rms}), 5 Hz to 500 Hz, 10 min, three axes
Shock	
Non-operating	294 m/s ² (30 G), half-sine, 11 ms duration



Index

Index

A

Accessories
 optional, 1-2
 standard, 1-2
AUDIO CHANNEL submenu, 2-15
Audio click, 2-16
AUDIO GROUP submenu, 2-14

B

BLACK 1 connector, 2-22
BLACK 2 connector, 2-22
Black submenu (Option BK only), 2-20

C

Circle overlay, 2-12
CIRCLE submenu, 2-12
Commands
 Rules for forming, 3-1
 Syntax, 3-1

D

DVG7 features, 1-1
DVG7 module main menu, 2-6

E

EDH insertion, 2-19
Electrical specifications, A-1
Embedded audio, 1-1, 2-14
Environmental specifications, A-2

F

Factory default settings, 2-23
Functional check, 1-3

H

Hierarchy (SCPI), 3-3

I

ID TEXT submenu, 2-11
Installation, 1-3

L

Logo overlay, 2-10
LOGO submenu, 2-10

M

Manuals, Related, iii
MASS MEMORY commands, 3-5
MOVING PICTURE submenu, 2-8

O

Operating procedure, 2-1
Option, 1-2
Optional accessories, 1-2
OUTPUT commands, 3-6
OVERLAY submenu, 2-9

P

Product description, 1-1

R

Rear-panel connectors, 2-22
Related Manuals, iii
Remote commands, 3-5
Rules, Command forming, 3-1

S

SCPI, Subsystem hierarchy tree, 3-3
SCPI commands and queries syntax, 3-3-3-4
SIGNAL 1 connector, 2-22
SIGNAL 2 connector, 2-22
Signal set assigned to the test signal buttons, 2-3

Specifications

- Electrical, A-1
- Environmental, A-2
- Standard accessories, 1-2
- Syntax, Command, 3-1

T

- Text overlay, 2-11

- TIMING submenu, 2-17

V

- VIDEO submenu, 2-18

User Manual



HDLG7 HD Dual Link Video Generator

Copyright © Tektronix. All rights reserved. Licensed software products are owned by Tektronix or its subsidiaries or suppliers, and are protected by national copyright laws and international treaty provisions.

Tektronix products are covered by U.S. and foreign patents, issued and pending. Information in this publication supercedes that in all previously published material. Specifications and price change privileges reserved.

TEKTRONIX and TEK are registered trademarks of Tektronix, Inc.

Contacting Tektronix

Tektronix, Inc.
14200 SW Karl Braun Drive
P.O. Box 500
Beaverton, OR 97077
USA

For product information, sales, service, and technical support:

- In North America, call 1-800-833-9200.
- Worldwide, visit www.tektronix.com to find contacts in your area.

Table of Contents

Preface	iii
About This Manual	iii
Related Manuals	iii
Getting Started	
Product Description	1-1
Accessories	1-2
Options	1-2
Installation	1-2
Functional Check	1-2
Operating Basics	
Operating Procedure	2-1
Selecting a Format	2-2
Selecting a Test Signal	2-4
Selecting the Converter Mode	2-5
HDLG7 Module Main Menu	2-7
Rear-Panel Connectors	2-10
Factory Default Settings	2-11
Reference	
Syntax	3-1
Programming Model	3-1
SCPI Commands and Queries	3-1
Remote Commands	3-3
OUTPUT Commands	3-3
SENSE Commands	3-6
Commands Examples	3-7
Generating Dual Link Signals from Converted Input	3-7
Generating Synthesized Dual Link Signals	3-7
Generating Black and White Dual Link Signals	3-7
Setting Timing Offset of Link B Relative to Link A	3-8
Appendices	
Appendix A: Specifications	A-1
Electrical Characteristics	A-1
Mechanical Characteristics	A-4
Environmental Characteristics	A-4
Index	

List of Figures

Figure 2-1: Front-panel test signal buttons	2-4
Figure 2-2: HDLG7 module main menu	2-7
Figure 2-3: LINK OFFSET submenu	2-9
Figure 2-4: HDLG7 module rear-panel connectors	2-10
Figure 3-1: Example of SCPI subsystem hierarchy	3-2

List of Tables

Table 1-1: Standard and optional accessories	1-2
Table 2-1: Signal set assigned to the test signal buttons	2-4
Table 2-2: Factory default settings	2-11
Table A-1: 4:2:2 serial digital video signal input	A-1
Table A-2: Dual link serial video outputs	A-1
Table A-3: Video signal content	A-2
Table A-4: Synthesizer generator test signals	A-2
Table A-5: Embedded audio and ancillary data	A-2
Table A-6: Supported input and output formats (SMPTE 274M to SMPTE 372M standards)	A-3
Table A-7: Mechanical characteristics	A-4
Table A-8: Environmental characteristics	A-4

Preface

This manual documents the capabilities, operation, and specifications of the HDLG7 HD Dual Link Video Generator module.

About This Manual

This manual is composed of the following sections:

- *Getting Started* contains a product description and a functional check procedure.
- *Operating Basics* explains how to operate the HDLG7 module using the menus and front-panel buttons.
- *Reference* provides the syntax used in command descriptions and describes all programming commands.
- *Appendices* provides the specifications.

Related Manuals

The following documents are also available.

- The *TG700 TV Signal Generator Platform Service Manual* (Tektronix part number 070-A800-XX) describes how to maintain and service the mainframe and generator modules. This manual is an optional accessory.
- The *TG700 TV Signal Generator Platform Module Installation Instructions* (Tektronix part number 070-A824-XX) describes how to install and remove the modules, and how to upgrade the firmware of the mainframe.



Getting Started

Getting Started

This section contains the following information:

- Product description
- Accessories
- Options
- Installation
- Functional check

Product Description

The HDLG7 HD Dual Link Video Generator module is designed to be installed in the TG700 TV Signal Generator Platform.

The HDLG7 module can be operated in either of two modes of operation. One mode of operation is a dual link generator, outputting some standard test signals. The other mode of operation is a converter. The module will convert a SMPTE 292M serial digital video stream carrying a SMPTE 274M signal to a SMPTE 372M serial digital dual link video signal. Table A-6 indicates which dual link outputs can be converted from each input format. The types of conversion are discussed in “Selecting the Converter Mode” in Operating Basics.

- Two pairs of dual link outputs
- Dual link outputs include SMPTE 352 payload
- Wide variety of 1080i, 1080p, and 1080PsF output formats
- Support the following sampling structures:
4:4:4 GBR, 4:4:4:4 GBR+A, 4:4:4 YCbCr, 4:4:4:4 YCbCr+A, 4:2:2 YCbCr, and 4:2:2:4 YCbCr+A
- Test signals; Color Bars, Linearity, Flat Field, Monitor, and Pulse Bar
- Adjustable timing offset between link A and link B outputs
- Full remote control using the Ethernet interface

Accessories

Table 1-1 lists the standard and optional accessories provided with the HDLG7 module.

Table 1-1: Standard and optional accessories

Accessory	Std.	Opt.	Tektronix part number
TG700 TV Signal Generator Platform Module Installation Instructions	●		070-A824-XX
TG700 Signal Generator Platform Software Library CD-ROM	●		062-A249-XX
TG700 TV Signal Generator Platform Service Manual		●	070-A800-XX

Options

This subsection describes the options available for the HDLG7 module. The following option is available:

Option D1 (Test data report)

Option D1 (Test Data Report)

A calibration test data report will be provided with the HDLG7 module when this option is specified.

Installation

Refer to the *TG700 TV Signal Generator Platform Module Installation Instructions* for instructions on how to install the HDLG7 module.

Functional Check

The following procedure determines whether the module is operating correctly.

Required equipment

The following equipment is required for the functional check:

- HDTV digital video generator
- HDTV waveform monitor
- Three 75 Ω BNC cables

Procedure

1. Install the module into the TG700 Platform mainframe using the installation procedures described in the *TG700 TV Signal Generator Platform User Manual*.
2. Power on the TG700 TV Signal Generator Platform by connecting it to the power source. The initialization of all the installed modules is executed.
3. Check that no error messages appear on the LCD display.
4. Warm up the instrument for 20 minutes.

Checking the Generator Function.

5. Press the front-panel **MODULE** button until the HDLG7 main menu shown below appears.

HDLG7 [x] : STATUS : SMPTE HD/SD Compat. 1080 59.94i GBR 4:4:4 12 bits

6. Press the **FORMAT** button and use the left (◀) or right (▶) arrow button to select the **1080 59.94p** format, and then press the **ENTER** button.
7. Press the **COLOR BAR** button to select **SMPTE HD/SD Compat.**, and then press the **CANCEL** button to return to the main menu.
8. Connect the upper **LINK A** connector to the **INPUT A** connector on the HDTV waveform monitor using a 75 Ω BNC cable.
9. Connect the upper **LINK B** connector to the **INPUT B** connector on the HDTV waveform monitor using the 75 Ω BNC cable.
10. Set the waveform monitor to view the **INPUT A** signal.
11. Check that the appropriate color bars signal is displayed.
12. Set the waveform monitor to view the **INPUT B** signal.
13. Check that the appropriate color bars signal is displayed.
14. Change the BNC cable from the upper **LINK A** connector to the lower **LINK A** connector.
15. Change the BNC cable from the upper **LINK B** connector to the lower **LINK B** connector.
16. Repeat steps 10 through 13 for the lower **LINK A** and **LINK B** connectors.

Checking the Converter Function.

17. Set the HDTV digital video generator as indicated below:
 - Output signal: 100% Color Bars
 - Format: 1080 59.94i
18. Connect the output connector on the HDTV digital video generator to the **HD SDI IN** connector on the HDLG7 using the 75 Ω BNC cable.
19. Press the **FORMAT** button and use the left (◀) or right (▶) arrow button to select **1080 59.94p**, and then press the **ENTER** button.
20. Press the **OTHER** button to select the converter mode.
21. Set the waveform monitor to view the INPUT A signal.
22. Check that the appropriate color bars signal is displayed.
23. Set the waveform monitor to view the INPUT B signal.
24. Check that the appropriate color bars signal is displayed.
25. Change the BNC cable from the lower **LINK A** connector to the upper **LINK A** connector.
26. Change the BNC cable from the lower **LINK B** connector to the upper **LINK B** connector.
27. Repeat steps 21 through 24 for the upper LINK A and LINK B connectors.



Operating Basics

Operating Basics

This section explains the operation of the HDLG7 module using the front-panel buttons and menus. It also describes the rear-panel connectors.

Refer to the *TG700 TV Signal Generator Platform User Manual* for a detailed explanation of the front-panel buttons and the LCD display.

Operating Procedure

After the module is installed in the mainframe, and the mainframe is installed in the rack or other location where it will be used, access each function of the module with the following procedure:

1. Connect the power connector on the rear panel to the AC electric power source using the power cord.

Electric power is supplied to the mainframe.

2. Wait until the power up initialization process is complete, and check that no error messages appear on the display.
3. Following the initialization process, the mainframe main menu appears, as shown:



TG700: PRESET

4. Press the front-panel **MODULE** button until the HDLG7 module main menu appears, as shown:

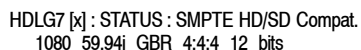

HDLG7 [x]: STATUS: SMPTE HD/SD Compat.
1080 59.94i GBR 4:4:4 12 bits

For Converting an Input Signal into a Dual Link Signal.

5. Connect an HD SDI signal to the **HD SDI IN** connector.
6. Select the signal format for the output signal. Refer to *Selecting a Format* on page 2-2 for more information.

NOTE. To avoid an input signal error, select the output signal format that matches the input signal. Refer to Table A-6 in Appendix A.

7. Select the converter mode for outputting a dual link signal. Refer to *Selecting the Converter Mode* on page 2-5 for more information.
8. Press the front-panel arrow buttons to select the desired main menu item or submenu.

For Outputting a Dual Link Test Signal.

9. Select the test signal you want to output. Refer to *Selecting a Test Signal* on page 2-4 for more information.
10. Select the signal format for the output signal. Refer to *Selecting a Format* on page 2-2 for more information.
11. Press the front-panel arrow buttons to select the desired main menu item or submenu.

Refer to *HDLG7 Module Main Menu* beginning on page 2-7 for detailed information about the main menu items and the submenu items.

Selecting a Format

When you press the front-panel FORMAT button, you can select the following format for the output signals:

1080 23.98sF	1080 24sF	1080 23.98p	1080 24p
1080 25p	1080 29.97p	1080 30p	1080 50i
1080 59.94i	1080 60i	1080 50p	1080 59.94p
1080 60p			

Perform the following steps to select the format:

1. Confirm that any menu item of the HDLG7 module main menu is displayed. If the menu is not displayed, press the front-panel **MODULE** button until the HDLG7 module main menu appears, as shown:

HDLG7 [x]: STATUS: 100% Color Bars 1080 59.94i GBR 4:4:4 12 bits

2. Press the **FORMAT** button. The menu display changes as follows:

HDLG7 [x]: SELECT FORMAT
1080 59.94i (Current)

3. Press the left (◀) or right (▶) arrow button to select one of the signal formats, and then press the **ENTER** button to confirm the selection.

NOTE. Framing resynchronization occurs when the signal format is changed.

NOTE. Selecting the 1080 50p, 1080 59.94p, or 1080 60p format forces the sampling structure to be set to YCbCr 4:2:2 10 bits. Refer to the *SAMPLE STRUCTURE/DEPTH* on page 2-8 for information about sampling structures.

NOTE. The same HD clock is supplied to all the modules at the same time. Therefore as the format is changed for the HDLG7, it will affect the HD clock going to the HDVG7 or AWVG7. If the HDVG7 is set for a format that requires an even clock rate (74.25 MHz) and the HDLG7 is changed to a format that requires an odd clock rate (74.25/1.001 MHz), the output of the HDVG7 video data stream may not be recognized as a legal format.

For the HDVG7 and AWVG7, a warning appears before the clock is changed (see below). This message does not appear when changing clock rates on the HDLG7 module.

* HD Clock Select, Disable 74.25 MHz? *
* Yes : ENTER / No : CANCEL *

Selecting a Test Signal

All signal sets available in the module are already assigned to the corresponding test signal buttons (see Figure 2-1). When you press any of the buttons, one of the signals in the signal set is output.

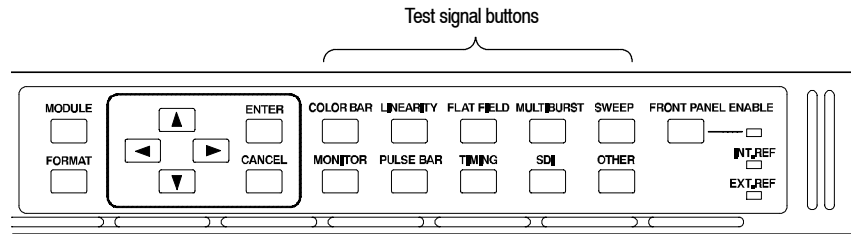
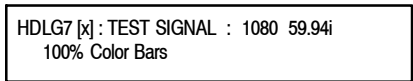

Figure 2-1: Front-panel test signal buttons

For example, when you press the **COLOR BAR** test signal button, you can output the **100% Color Bars** signal in the Color Bars signal set. When you press a test signal button, the menu display changes as follows:



Press the left (◀) or right (▶) arrow button, or press the test signal button repeatedly to select different signals assigned to the test signal button.

Press the **CANCEL** button to return to the main menu.

Table 2-1 lists the signal set assigned to each test signal button and the signals that can be selected in the signal set.

Table 2-1: Signal set assigned to the test signal buttons

Button name	Signal set	Signals in the signal set
COLOR BAR	Color Bars	100% Color Bars, 75% Color Bars, SMPTE HD/SD Compatible ¹
LINEARITY	Linearity	5 Step Staircase, Ramp, Valid Ramp
FLAT FIELD	Flat Fields	0% Flat Field, 10% Flat Field, 20% Flat Field, 30% Flat Field, 40% Flat Field, 50% Flat Field, 60% Flat Field, 70% Flat Field, 80% Flat Field, 90% Flat Field, 100% Flat Field
MULTI BURST	-----	-----
SWEEP	-----	-----

Table 2- 1: Signal set assigned to the test signal buttons (Cont.)

Button name	Signal set	Signals in the signal set
MONITOR	Monitor	100% Red Field, 75% Red Field, 100% Green Field, 75% Green Field 100% Blue Field, 75% Blue Field, Convergence
PULSE BAR	Pulse & Bar	2T30 Pulse and Bar
TIMING	-----	-----
SDI	-----	-----
OTHER	-----	Use this button to select the converter mode of operation. Refer to <i>Selecting the Converter Mode</i> for more information.

¹ SMPTE HD/SD Compatible refers to SMPTE RP219 Color Bar (I/Q Even).

Selecting the Converter Mode

Selecting the converter mode allows a SMPTE 292M 4:2:2 serial digital signal applied to the HD SDI IN connector to be converted into a dual link output format. Table A-6 on page A-3 indicates which dual link outputs can be converted from each input format. The details of each conversion type are as follows:

60, 59.94, or 50 Hz Progressive Formats. The HDLG7 converts the input interlace signal (60i, 59.94i, or 50i) to a progressive signal by doubling the frame rate. The input signal is copied to both Link A and Link B, but the payload identifier is modified to indicate a dual-link signal. The results are a 4:2:2 YCbCr 10-bit signal at the faster progressive rate (60p, 59.94p, or 50p).

4:4:4 YCbCr Formats. The HDLG7 converts the input 4:2:2 YCbCr signal to 4:4:4 YCbCr signal by up-interpolating the chroma channel data samples. This is accomplished by using several incoming data samples before and after the data samples to derive the extra sample point. If 10-bit sample structure is selected, the alpha channel is set to blanking levels or is controlled by the ALPHA CHANNEL DATA menu. If 12 bit is chosen, the addition 2 LSB bits are set to zero on the Y and co-sited Cb and Cr samples. The derived Cb and Cr samples will contain derived LSB bits.

4:4:4 RGB Formats. The HDLG7 converts the input 4:2:2 YCbCr signal to 4:4:4 YCbCr as described above. Then the signal is color-space converted using the inverse linear transform defined in SMPTE 274M. If 10-bit sample structure is selected, the alpha channel is set to blanking levels or is controlled by the ALPHA CHANNEL DATA menu. If 12 bit is chosen, the addition 2 bits (LSB) are computed from the linear transform calculations.

4:2:2 YCbCr 12 Bit Formats. The HDLG7 converts the input 4:2:2 YCbCr signal to 4:2:2 YCbCr 12 bits by setting zeros for the additional 2 bits (LSB). The alpha channel is set to blanking levels or is controlled by the ALPHA CHANNEL DATA menu.

Perform the following steps to select the converter mode:

1. Press the front-panel **OTHER** button. The menu display changes as follows:

HDLG7 [x] : CONVERTER
Normal (GBR 4:4:4 12 bits)

2. Press the left (◀) or right (▶) arrow button, or press the **OTHER** button repeatedly to select between **Normal** and **Y to GBR**.
 - **Normal:** The incoming YCbCr signal is converted to a normal dual-link output.
 - **Y to GBR:** The incoming Y data is applied to the G, B, and R outputs. This allows higher bandwidth data, such as multiburst or sweep to be placed on all three channels. If the sampling structure is for a YCbCr output, the Y to GBR selection is not available.
3. Press the **CANCEL** button to return to the main menu.

NOTE. If you select 1080 50p, 1080 59.94p, or 1080 60p as the output format, you will not be able to select any sampling structure other than YCbCr 4:2:2 10 bits. To avoid this restriction when using the converter mode, change the output format to match the input format.

HDLG7 Module Main Menu

You can set the sampling structure/pixel depth, alpha channel signal, and timing offset between the Link A and Link B outputs using the HDLG7 module main menu.

Use the up (▲) or down (▼) arrow button to scroll through the main menu. Figure 2-2 shows the HDLG7 module main menu.

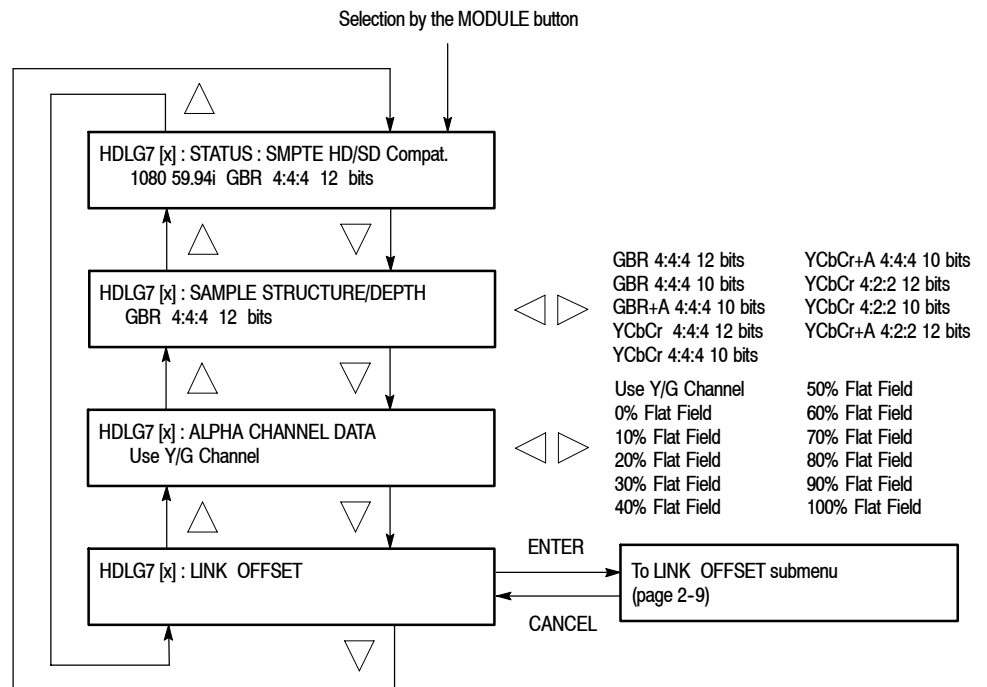

Figure 2-2: HDLG7 module main menu

STATUS. Displays the instrument operating mode, output signal format, and output sample structure.

Converter Mode:

HDLG7 [x] : STATUS : CONVERTER (Normal)
 1080 60i GBR+A 4:4:4 10 bits

- **CONVERTER (Normal):** Indicates the incoming HD-SDI video stream is being converted in a normal mode. The other choice is (Y to GBR) where the incoming Y data is placed on the G, B, and R channels on the output. Y to GBR is only selectable in the GBR sampling structure.

- **1080 60i**: Indicates the incoming signal format. If there is no input or the format is not the correct rate, the following message will appear on the second line of the LCD; “Input Signal Error (Check FORMAT)”
- **GBR+A 4:4:4 10 bits**: Indicates the output sampling structure.

Generator Mode:

HDLG7 [x] : STATUS : 100% Color Bars 1080 24sF GBR+A 4:4:4 10 bits

- **100% Color Bars**: Indicates the name of the signal currently being generated. So as different generator signal are selected, their name will be displayed.
- **1080 24sF**: Indicates the output format.
- **GBR+A 4:4:4 10 bits**: Indicates the output sampling structure.

SAMPLE STRUCTURE/DEPTH. Selects the sampling structure and pixel depth of the output signal. Use the left (◀) or right (▶) arrow button to select the format.

The choices are:

- **GBR 4:4:4 12 bits**
- **GBR 4:4:4 10 bits**
- **GBR+A 4:4:4 10 bits**
- **YCbCr 4:4:4 12 bits**
- **YCbCr 4:4:4 10 bits**
- **YCbCr+A 4:4:4 10 bits**
- **YCbCr 4:2:2 12 bits**
- **YCbCr 4:2:2 10 bits**
- **YCbCr+A 4:2:2 12 bits**

Press the **ENTER** button to confirm the selection.

NOTE. When the 1080 50p, 1080 59.94p, or 1080 60p format is selected, the HDLG7 forces the sampling structure to YCbCr 4:2:2 10 bits, and no other sampling structure is allowed.

NOTE. If the current output format is 1080 23.98sF, 1080 24sF, 1080 23.98p, 1080 24p, 1080 25p, 1080 29.97p, 1080 30p, 1080 50i, 1080 59.94i, or 1080 60i, you may select YCbCr 4:2:2 10 bits as the sampling structure. However, the output signals produced on Link A and Link B are not dual-link signals. The HDLG7 will produce two single-link outputs, with incoming ancillary and embedded audio being placed on LINK A and none on LINK B.

ALPHA CHANNEL DATA. Sets the alpha channel signal. Use the left (◀) or right (▶) arrow button to select **Use Y/G Channel, 0% Flat Field, 10% Flat Field, 20% Flat Field, 30% Flat Field, 40% Flat Field, 50% Flat Field, 60% Flat Field, 70% Flat Field, 80% Flat Field, 90% Flat Field, or 100% Flat Field.** Press the **ENTER** button to confirm the selection.

The alpha channel data are used only with the following sampling structures: GBR+A 4:4:4 10 bits, YCbCr+A 4:4:4 10 bits, and YCbCr+A 4:2:2 12 bits.

LINK OFFSET. Sets the timing offset of the Link B output relative to the Link A output. When you select this menu item and then press the ENTER button, you will access the LINK OFFSET submenu. Refer to *LINK OFFSET Submenu* on page 2-9 for detailed information.

LINK OFFSET Submenu

This menu allows you to adjust the timing offset of the Link B output relative to the Link A output. Figure 2-3 shows the LINK OFFSET submenu.

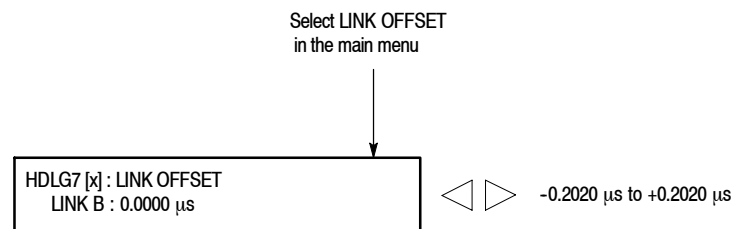

Figure 2-3: LINK OFFSET submenu

Use the left (◀) or right (▶) arrow button to change the value. You can set the value from -0.2020 μs to +0.2020 μs in 0.0135 μs steps.

NOTE. You can reset the offset value to zero by pressing the left (◀) and right (▶) arrow buttons simultaneously.

Rear-Panel Connectors

The HDLG7 module is equipped with one input connector and two dual link signal output connectors. Figure 2-4 shows the HDLG7 module rear-panel connectors.

NOTE. Each pair of connectors (*LINK A* and *LINK B*) will both output the same signal.

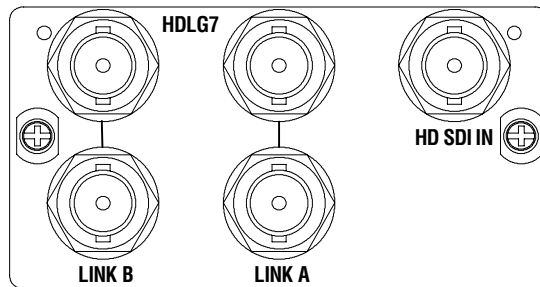

Figure 2-4: HDLG7 module rear-panel connectors

- **HD SDI IN:** HD-SDI (4:2:2) video signal input.
- **LINK A:** HD-SDI link A video signal outputs.
- **LINK B:** HD-SDI link B video signal outputs.

Factory Default Settings

Table 2-2 shows the factory default settings for the HDLG7 module. The factory default settings put the HDLG7 module in the Generator mode. These settings are recalled when you select **Factory Default** from the **PRESET : RECALL** menu item in the mainframe main menu.

Table 2-2: Factory default settings

Menu item name	Settings
STATUS	SMPTE HD/SD Compat. 1080 59.94i GBR 4:4:4 12 bits
SAMPLE STRUCTURE/DEPTH	GBR 4:4:4 12 bits
ALPHA CHANNEL DATA	Use Y/G Channel
LINK OFFSET	0.0000 μ s



Reference

Syntax

This section contains information on the Standard Commands for Programmable Instruments (SCPI) and the programming structure you can use to program your HDLG7 module.

Programming Model

Specific conditions must exist before programming commands will affect the test signal generated by a module.

Selecting the Module

Select the module using the :INSTRument:SElect command before executing any commands. Many of the commands used by the HDLG7 module are shared by several modules and will be accepted without a reported error.

Command Arguments

Many commands will accept either string or numeric arguments. For example: a boolean argument can either be “1” or “ON”.

Default. Use this argument to set the parameter value to the default value.

SCPI Commands and Queries

SCPI is a standard created by a consortium that provides guidelines for remote programming of instruments. These guidelines provide a consistent programming environment for instrument control and data transfer. This environment uses defined programming messages, instrument responses, and data format across all SCPI instruments, regardless of manufacturer. The HDLG7 module uses a command language based on the SCPI standard.

The SCPI language is based on a hierarchical or tree structure (see Figure 3-1) that represents a subsystem. The top level of the tree is the root node; it is followed by one or more lower-level nodes.

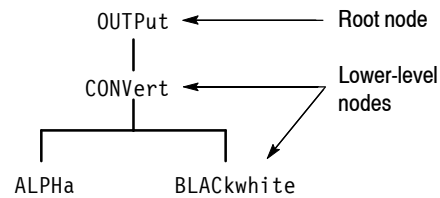

Figure 3- 1: Example of SCPI subsystem hierarchy

You can create commands and queries from these subsystem hierarchy trees. Commands specify actions for the instrument to perform. Queries return measurement data and information about parameter settings.

For more information on SCPI commands and programming structure, refer to the *TG700 Signal Generator Platform User Manual*.

Remote Commands

This section describes the remote commands used to control the HDLG7 module remotely. The commands to the module are divided into the following two groups:

- OUTPUT commands
- SENSE commands

OUTPUT Commands

Use these commands control the output parameters of the module.

Command Tree

```
:OUTPut1
  :ALPHa                COPY_YG|FF_OP|FF_10P|FF_20P|FF_30P|
                        FF_40P|FF_50P|FF_60P|FF_70P|FF_80P|
                        FF_90P|FF100P
  :CONVert
    :BLACKwhite        ON|OFF
    :STATe?
  :SAMPling
    :SElect            GBR444_12B|GBR444_10B|GBR444A_10B|
                        YCB444_12B|YCB444_10B|YCB444A_10B|
                        YCB422_12B|YCB422_10B|YCB422A_12B
  :STANdard
                        HD1080_60P|HD1080_59P|HD1080_50P|
                        HD1080_60I|HD1080_59I|HD1080_50I|
                        HD1080_30P|HD1080_29P|HD1080_25P|
                        HD1080_24P|HD1080_23P|HD1080_24SF|
                        HD1080_23SF
  :SYNThesize
    :STATe              ON|OFF
    :SIGNal            COLBAR_100P|COLBAR_75P|COLBAR_SMPTE|
                        FF_OP|FF_10P|FF_20P|FF_30P|FF_40P|
                        FF_50P|FF_60P|FF_70P|FF_80P|FF_90P|
                        FF_100P|LIN_5STEP|LIN_RAMP|LIN_VRAMP|
                        MON_RED|MON_75RED|MON_GREEN|
                        MON_75GREEN|MON_BLUE|MON_75BLUE|
                        MON_CONV|PULSE_2T30
```

Command Description

`:OUTPut1:ALPHa COPY_YG|FF_0P|FF_10P|FF_20P|FF_30P|FF_40P|
FF_50P|FF_60P|FFF70P|FF80P|FF_90P|FF_100P|`

Sets the alpha channel signal. The choices are COPY_YG (fills the alpha channel with Y or G data from the input signal), FF_0P (0% Flat Field), FF_10P (10% Flat field), FF_20P (20% Flat field), FF_30P (30% Flat field), FF_40P (40% Flat field), FF_50P (50% Flat field), FF_60P (60% Flat field), FF_70P (70% Flat field), FF_80P (80% Flat field), FF_90P (90% Flat field), and FF_100P (100% Flat field).

`:OUTPut1:ALPHa?`

Returns the current alpha channel signal.

`:OUTPut1:CONVert:BLACKwhite ON|OFF`

Turns the black and white mode on or off. When the current color space is GBR, G data is copied to B and R field for getting a black and white display. When the color space is YCbCr, the command has no effect.

`:OUTPut1:CONVert:BLACKwhite?`

Returns the current black and white mode status.

`:OUTPut1:CONVert:STATE?`

Returns the video standard and sampling structure information from the second line of the status display.

`:OUTPut1:SAMPling:SElect GBR444_12B|GBR444_10B|GBR444A_10B|
YCB444_12B|YCB444_10B|YCB444A_10B|
YCB422_12B|YCB422_10B|YCB422A_12B`

Sets the sampling structure for the output test signal. The options are as follows:

GBR444_12B	4:4:4 GBR 12 bits
GBR444_10B	4:4:4 GBR 10 bits
GBR444A_10B	4:4:4 GBR+A 10 bits
YCB444_12B	4:4:4 YCbCr 12 bits
YCB444_10B	4:4:4 YCbCr 10 bits
YCB444A_10B	4:4:4 YCbCr+A 10 bits
YCB422_12B	4:2:2 YCbCr 12 bits
YCB422_10B	4:2:2 YCbCr 10 bits
YCB422A_12B	4:2:2 YCbCr+A 12 bits

:OUTPut1:SAMPling:SElect?

Returns the current sampling structure.

```
:OUTPut1:STANdard HD1080_60P|HD1080_59P|HD1080_50P|HD1080_60I|
                  HD1080_59I|HD1080_50I|HD1080_30P|HD1080_29P|
                  HD1080_25P|HD1080_24P|HD1080_23P|HD1080_24SF|
                  HD1080_23SF
```

Sets the video standard of the output signal.

:OUTPut1:STANdard?

Returns the current video standard.

:OUTPut1:SYNThesize:STATe ON|OFF

Turns the synthesizer mode on or off.

:OUTPut1:SYNThesize:STATe?

Returns the current synthesizer mode status.

```
:OUTPut1:SYNThesize:SIGNal COLBAR_100P|COLBAR_75P|COLBAR_SMPTE|
                            FF_0P|FF_10P|FF_20P|FF_30P|FF_40P|
                            FF_50P|FF_60P|FF70_P|FF_80P|FF_90P|
                            FF_100P|LIN_5STEP|LIN_RAMP|LIN_VRAMP|
                            MON_RED|MON_75RED|MON_GREEN|
                            MON_75GREEN|MON_BLUE|MON_75BLUE|
                            MON_CONV|PULSE_2T30
```

Sets the output test signal. The options are as follows:

COLBAR_100P	100% Color Bars
COLBAR_75P	75% Color Bars
COLBAR_SMPTE	SMPTE HD/SD Compatible Color Bars
FF_0P	0% Flat Field
FF_10P	10% Flat Field
FF_20P	20% Flat Field
FF_30P	30% Flat Field
FF_40P	40% Flat Field
FF_50P	50% Flat Field
FF_60P	60% Flat Field
FF_70P	70% Flat Field
FF_80P	80% Flat Field
FF_90P	90% Flat Field
FF_100P	100% Flat Field
LIN_5STEP	5 Step Staircase
LIN_RAMP	Ramp
LIN_VRAMP	Valid Ramp
MON_RED	100% Red Field

MON_75RED	75% Red Field
MON_GREEN	100% Green Field
MON_75GREEN	75% Green Field
MON_BLUE	100% Blue Field
MON_75BLUE	75% Blue Field
MON_CONV	Convergence
PULSE_2T30	2T30 pulse and bar

:OUTPut1:SYNThesize:SIGNa1?

Returns the current output signal.

SENSE Commands

Use these commands to set the timing offset of the LINK B outputs relative to the LINK A outputs.

Refer to *Operating Basics* for detailed information about the setting range.

Command Tree

```
:SENSe1
  :CORRection
    :MDElay
      :HORizontal <numeric_value>
```

Command Description

```
:SENSe1:CORRection:MDElay:HORizontal <numeric_value>
```

Sets the horizontal timing offset of the LINK B outputs. The timing resolution is clock-cycles. The units are microseconds.

```
:SENSe1:CORRection:MDElay:HORizontal?
```

Returns the current horizontal timing offset of the LINK B outputs.

Commands Examples

This section shows some examples of remote commands to generate dual link signals and to set the timing offset of the LINK B outputs.

Generating Dual Link Signals from Converted Input

To output dual link signals from a converted input where the source test signal is 1080 59.94i standard, 100% Color Bars from the HDVG7 module in slot 4. The HDLG7 module is in slot 3, the sampling structure is “GBR 4:4:4 10 bits” and alpha channel data of 10% Flat Field is inserted:

```
INST:SEL "HDVG7:4"  
INST: NSEL 4;:MMEM:LOAD:SIGN 4,"/1080 59.94i/COLOR  
BAR/100%^Color Bars"  
INST:SEL "HDLG7:3"  
OUTP1:SYNT:STAT OFF  
OUTP1:SAMP:SEL GBR444A_10B  
OUTP1:ALPH FF_10P
```

Generating Synthesized Dual Link Signals

To generate dual link signals where the HDLG7 module is in slot 3, the video standard is 1080 59.94i, the test signal is 100% Color Bars, the sampling structure is “YCbCr 4:4:4 10 bits” and no alpha channel data is inserted:

```
INST:SEL "HDLG7:3"  
OUTP1:SYNT:STAT ON  
OUTP1:STAN HD1080_59I  
OUTP1:SYNT:SIGN COLBAR_100P  
OUTP1:SAMP:SEL YCB444_10B
```

Generating Black and White Dual Link Signals

To output black and white dual link signals from a converted input where the sampling structure is “GBR 4:4:4 12 bits”:

```
OUTP1:SYNT:STAT OFF  
OUTP1:SAMP:SEL GBR444_12B  
OUTP1:CONV:BLAC ON
```

Setting Timing Offset of Link B Relative to Link A

To set the timing offset of the LINK B outputs to 0.0269 μ s from the LINK A outputs:

```
SENS1:CORR:MDEL:HOR 0.0269
```



Appendices

Appendix A: Specifications

Tables A-1 through A-8 list the electrical, mechanical, and environmental characteristics of the HDLG7 module.

Electrical Characteristics

Table A- 1: 4:2:2 serial digital video signal input

Characteristic	Description
Number of inputs	1
Format	Compatible with SMPTE 292M. See Table A-6 for supported input and output formats.
Input type	75 Ω BNC
Cable loss accommodation	0-20 dB attenuation with 1/SQRT(f) characteristic at 1/2 of serial rate.
Launch amplitude accommodation, typical	800 mV \pm 10% for full specification 800 mV \pm 30% up to 20 dB cable attenuation
Jitter tolerance, typical	0.35 \pm 0.1 UI p-p above 1 MHz. Increases proportional to 1/f below 1 MHz.
Return loss	\geq 15 dB, 5 MHz to 750 MHz \geq 10 dB, 750 MHz to 1.485 GHz

Table A- 2: Dual link serial video outputs

Characteristic	Description
Number of outputs	2 on each channel (link)
Format	Compatible with SMPTE 372M and SMPTE 292M
Output type	75 Ω BNC
Output level	800 mV \pm 10%
Rise and fall times	270 ps max. (20% to 80%)
Jitter, typical	135 ps max. (0.2 UI alignment jitter)
Return loss	\geq 15 dB, 5 MHz to 750 MHz \geq 10 dB, 750 MHz to 1.485 GHz

Table A-3: Video signal content

Characteristic	Description
Conversion accuracy, typical	0.4%
Accuracy of synthesizer generated test signals, typical	0.2%
Timing offset of Link B in reference to Link A	± 200 ns min. Adjustment in steps of the clock period (13.5 ns)

Table A-4: Synthesizer generator test signals

Characteristic	Description
Color Bars	100% Color Bars, 75% Color Bars, SMPTE HD/SD Compatible ¹
Linearity	Ramp, Valid Ramp, 5 Step Staircase
Flat Field	0% Flat Field, 10% Flat Field, 20% Flat Field, 30% Flat Field, 40% Flat Field, 50% Flat Field, 60% Flat Field, 70% Flat Field, 80% Flat Field, 90% Flat Field, 100% Flat Field
Monitor	100% Red Field, 75% Red Field, 100% Blue Field, 75% Blue Field, 100% Green Field, 75% Green Field, Convergence
Pulse bar	2T30 Pulse and Bar

¹ SMPTE HD/SD Compatible refers to SMPTE RP219 Color Bar (I/Q Even).

Table A-5: Embedded audio and ancillary data

Characteristic	Description
Embedded audio	Embedded audio on 4:2:2 video input is placed on the Link A video outputs as per SMPTE 372M.
Ancillary data	Embedded ancillary data on 4:2:2 video input is placed on the Link A video outputs as per SMPTE 372M.

Table A- 6: Supported input and output formats (SMPTE 274M to SMPTE 372M standards)

Input format (4:2:2 YCbCr/10 bit)	Format selection of dual link output	
1920 X 1080i 50 Hz	4:2:2 (YCbCr)/10 bit	1920 X 1080p 50Hz
	4:4:4 (YCbCr), 4:4:4:4 (YCbCrA)/10 bit	1920 X 1080i 50 Hz
	4:4:4 (YCbCr)/12 bit	1920 X 1080i 50 Hz
	4:4:4 (RGB), 4:4:4:4 (RGBA)/10 bit	1920 X 1080i 50 Hz
	4:4:4 (RGB)/12 bit	1920 X 1080i 50 Hz
	4:2:2 (YCbCr), 4:2:2:4 (YCbCrA)/12 bit	1920 X 1080i 50 Hz
1920 X 1080i 60/59.94 Hz	4:2:2 (YCbCr)/10 bit	1920 X 1080p 60/59.94Hz
	4:4:4 (YCbCr), 4:4:4:4 (YCbCrA)/10 bit	1920 X 1080i 60/59.94 Hz
	4:4:4 (YCbCr)/12 bit	1920 X 1080i 60/59.94 Hz
	4:4:4 (RGB), 4:4:4:4 (RGBA)/10 bit	1920 X 1080i 60/59.94 Hz
	4:4:4 (RGB)/12 bit	1920 X 1080i 60/59.94 Hz
	4:2:2 (YCbCr), 4:2:2:4 (YCbCrA)/12 bit	1920 X 1080i 60/59.94 Hz
1920 X 1080p/PsF 30/29.97 Hz	4:4:4 (YCbCr), 4:4:4:4 (YCbCrA)/10 bit	1920 X 1080p/PsF 30/29.97 Hz
	4:4:4 (YCbCr)/12 bit	1920 X 1080p/PsF 30/29.97 Hz
	4:4:4 (RGB), 4:4:4:4 (RGBA)/10 bit	1920 X 1080p/PsF 30/29.97 Hz
	4:4:4 (RGB)/12 bit	1920 X 1080p/PsF 30/29.97 Hz
	4:2:2 (YCbCr), 4:2:2:4 (YCbCrA)/12 bit	1920 X 1080p/PsF 30/29.97 Hz
1920 X 1080p/PsF 25 Hz	4:4:4 (YCbCr), 4:4:4:4 (YCbCrA)/10 bit	1920 X 1080p/PsF 25 Hz
	4:4:4 (YCbCr)/12 bit	1920 X 1080p/PsF 25 Hz
	4:4:4 (RGB), 4:4:4:4 (RGBA)/10 bit	1920 X 1080p/PsF 25 Hz
	4:4:4 (RGB)/12 bit	1920 X 1080p/PsF 25 Hz
	4:2:2 (YCbCr), 4:2:2:4 (YCbCrA)/12 bit	1920 X 1080p/PsF 25 Hz
1920 X 1080p/PsF 24/23.98 Hz	4:4:4 (YCbCr), 4:4:4:4 (YCbCrA)/10 bit	1920 X 1080p/PsF 24/23.98 Hz
	4:4:4 (YCbCr)/12 bit	1920 X 1080p/PsF 24/23.98 Hz
	4:4:4 (RGB), 4:4:4:4 (RGBA)/10 bit	1920 X 1080p/PsF 24/23.98 Hz
	4:4:4 (RGB)/12 bit	1920 X 1080p/PsF 24/23.98 Hz
	4:2:2 (YCbCr), 4:2:2:4 (YCbCrA)/12 bit	1920 X 1080p/PsF 24/23.98 Hz

Mechanical Characteristics

Table A-7: Mechanical characteristics

Characteristic	Description
Dimensions	
Height	41.5 mm (1.63 in)
Width	78.4 mm (3.1 in)
Depth	394 mm (15.5 in)
Weight	340 g (0.75 lb)

Environmental Characteristics

Table A-8: Environmental characteristics

Characteristic	Description
Temperature	
Operating	0° C to +50° C
Non-operating	-20° C to +60° C
Relative Humidity	
Operating	20 % to 80 % (No condensation); Maximum wet-bulb temperature 29.4° C
Non-operating	5 % to 90 % (No condensation); Maximum wet-bulb temperature 40.0° C
Altitude	
Operating	To 4.5 km (15,000 feet) Maximum operating temperature decreases 1° C each 300 m above 1.5 km.
Non-operating	To 15 km (50,000 feet)
Vibration	
Operating	3.04 m/s ² (0.31 G _{rms}), 5 Hz to 500 Hz, 10 min, three axes
Non-operating	23.3 m/s ² (2.38 G _{rms}), 5 Hz to 500 Hz, 10 min, three axes
Shock	
Non-operating	294 m/s ² (30 G), half-sine, 11 ms duration



Index

Index

A

Accessories
 optional, 1-2
 standard, 1-2

C

Commands
 Rules for forming, 3-1
 Syntax, 3-1
Commands examples, 3-7

E

Electrical specifications, A-1
Environmental specifications, A-4

F

Factory default settings, 2-11
Functional check, 1-2

H

HD SDI IN connector, 2-10
HDLG7 features, 1-1
HDLG7 module main menu, 2-7
Hierarchy (SCPI), 3-2

I

Installation, 1-2

L

LINK A connectors, 2-10

LINK B connectors, 2-10
LINK OFFSET submenu, 2-9

M

Manuals, Related, iii
Mechanical specifications, A-4

O

Operating procedure, 2-1
Option, 1-2
Optional accessories, 1-2
OUTPUT commands, 3-3

P

Product description, 1-1

R

Rear-panel connectors, 2-10
Related Manuals, iii
Remote commands, 3-3
Rules, Command forming, 3-1

S

SCPI, Subsystem hierarchy tree, 3-2
SCPI commands and queries syntax, 3-1–3-2
SENSE commands, 3-6
Signal set assigned to the test signal buttons, 2-4
Specifications
 Electrical, A-1
 Environmental, A-4
Standard accessories, 1-2
Syntax, Command, 3-1

User Manual



HDVG7 HDTV Digital Video Generator

Copyright © Tektronix. All rights reserved. Licensed software products are owned by Tektronix or its suppliers and are protected by United States copyright laws and international treaty provisions.

Tektronix products are covered by U.S. and foreign patents, issued and pending. Information in this publication supercedes that in all previously published material. Specifications and price change privileges reserved.

TEKTRONIX and TEK are registered trademarks of Tektronix, Inc.

Contacting Tektronix

Tektronix, Inc.
14200 SW Karl Braun Drive
P.O. Box 500
Beaverton, OR 97077
USA

For product information, sales, service, and technical support:

- In North America, call 1-800-833-9200.
- Worldwide, visit www.tektronix.com to find contacts in your area.

Table of Contents

Preface	iii
About This Manual	iii
Related Manuals	iii
Getting Started	
Product Description	1-1
Accessories	1-2
Options	1-2
Installation	1-3
Functional Check	1-3
Operating Basics	
Operating Procedure	2-1
Selecting an Output Signal	2-2
HDVG7 Module Main Menu	2-4
Rear-Panel Connectors	2-18
Factory Default Settings	2-19
Reference	
Syntax	3-1
Programming Model	3-1
SCPI Commands and Queries	3-3
Remote Commands	3-5
MASS MEMORY Commands	3-5
OUTPUT Commands	3-6
SENSE Commands	3-15
Appendices	
Appendix A: Specifications	A-1
Electrical Characteristics	A-1
Environmental Characteristics	A-2
Index	

List of Figures

Figure 2-1: Front-panel test signal buttons	2-3
Figure 2-2: HDVG7 module main menu	2-4
Figure 2-3: MOVING PICTURE submenu	2-6
Figure 2-4: OVERLAY submenu	2-7
Figure 2-5: LOGO submenu	2-8
Figure 2-6: ID TEXT submenu	2-9
Figure 2-7: CIRCLE submenu	2-10
Figure 2-8: AUDIO GROUP submenu	2-12
Figure 2-9: AUDIO CHANNEL submenu	2-13
Figure 2-10: TIMING submenu	2-15
Figure 2-11: VIDEO submenu	2-16
Figure 2-12: BLACK submenu (Option BK only)	2-17
Figure 2-13: HDVG7 module rear-panel connectors (Option BK) ..	2-19
Figure 3-1: Example of SCPI subsystem hierarchy	3-3

List of Tables

Table 1-1: Standard and optional accessories	1-2
Table 2-1: Signal set assigned to the test signal buttons	2-3
Table 2-2: Factory default settings	2-19
Table A-1: Serial digital video signal outputs	A-1
Table A-2: Serial digital black signal outputs (Option BK only) ..	A-1
Table A-3: Embedded audio	A-2
Table A-4: Environmental characteristics	A-2

Preface

This manual documents the capabilities, operation, and specifications of the HDVG7 HDTV Digital Video Generator module.

About This Manual

This manual is composed of the following sections:

- *Getting Started* contains product description and functional check procedure.
- *Operating Basics* explains how to operate the HDVG7 module using the menus and front-panel buttons.
- *Reference* provides the syntax used in command descriptions and describes all programming commands.
- *Appendices* provides the specifications.

Related Manuals

The following documents are also available.

- The *TG700 TV Signal Generator Platform Service Manual* (Tektronix part number 070-A800-XX) describes how to maintain and service the mainframe and generator modules. This manual is an optional accessory.
- The *TG700 TV Signal Generator Platform Module Installation Instructions* (Tektronix part number 070-A824-XX) describes how to install and remove the modules, and how to upgrade the firmware of the mainframe.



Getting Started

Getting Started

This section contains the following information:

- Product description
- Accessories
- Options
- Installation
- Functional check

Product Description

The HDVG7 HDTV Digital Video Generator module is designed to be installed in the TG700 TV Signal Generator Platform.

The module is an HDTV test signal generator which provides 1.485 Gb/s serial digital video signals in various formats. The module contains the following features:

- Two serial digital video outputs
- Two serial digital black outputs (option BK)
- Supports SMPTE 274M (1080), SMPTE 240M (1035), and SMPTE 296M (720)
- Overlay of circle, text, or logo on the video signal
- Generates a moving picture by scrolling the active picture area of the output test signal
- Up to 16 channels of Embedded Audio
- Full remote control using Ethernet interface

The module can generate video signals with 24 (or 20) bit embedded digital audio with a sample rate of 48 kHz.

The following audio frequencies are supported.

Silence	500 Hz	2000 Hz	8000 Hz
50 Hz	600 Hz	2400 Hz	9600 Hz
100 Hz	750 Hz	3000 Hz	10000 Hz
150 Hz	800 Hz	3200 Hz	12000 Hz
200 Hz	1000 Hz	4000 Hz	15000 Hz
250 Hz	1200 Hz	4800 Hz	16000 Hz
300 Hz	1500 Hz	5000 Hz	20000 Hz
400 Hz	1600 Hz	6000 Hz	

Accessories

Table 1-1 lists the standard and optional accessories provided with the HDVG7 Generator module.

Table 1-1: Standard and optional accessories

Accessory	Std.	Opt.	Tektronix part number
TG700 TV Signal Generator Platform Module Installation Instructions	●		070-A824-XX
TG700 Signal Generator Platform Software Library CD-ROM	●		062-A249-XX
TG700 TV Signal Generator Platform Service Manual		●	070-A800-XX

Options

This subsection describes the options available for the HDVG7 Generator module. The following options are available:

Option BK (Serial digital black output)

Option D1 (Test data report)

Option BK (Serial Digital Black Output)

Two serial digital black signal outputs are added to the HDVG7 Generator module when this option is specified.

Option D1 (Test Data Report)

A calibration test data report will be provided with the HDVG7 Generator module when this option is specified.

Installation

Refer to the *TG700 TV Signal Generator Platform Module Installation Instructions* for instructions on how to install the HDVG7 Generator module.

Functional Check

The following procedure determines whether the module is operating correctly.

Required equipment

The following equipment is required for the functional check:

- HDTV waveform monitor
- 75 Ω BNC cable

Procedure

1. Install the module into the TG700 Platform mainframe using the installation procedures described in the *TG700 TV Signal Generator Platform User Manual*.
2. Power on the TG700 TV Signal Generator Platform by connecting it to the power source. The initialization of all the installed modules is executed.
3. Check that no error messages appear on the LCD display.
4. Warm up the instrument for 20 minutes.
5. Press the front-panel **MODULE** button until the HDVG7 main menu shown below appears.



HDVG7 [x] : STATUS : 1080 59.94i
100% Color Bars

6. Press the **FORMAT** button and use the left (◀) or right (▶) arrow button to select a format, then press the **ENTER** button.
7. Press one of the front-panel test signal button (for example **COLOR BAR**) to output a signal.
8. Connect the **SIGNAL 1** connector to the HDTV waveform monitor using the 75 Ω BNC cable.
9. Set the waveform monitor to view the signal.
10. Check that the signal appears as expected. For example, if you selected a color bar signal in step 7, check that the color bar signal appears.

- 11.** Disconnect the BNC cable from the **SIGNAL 1** connector, and then connect the BNC cable to the **SIGNAL 2** connector.
- 12.** Check that the signal appears as expected.



Operating Basics

Operating Basics

This section explains the operation of the HDVG7 Generator module using the front-panel buttons and menus. It also contains descriptions of the rear-panel connectors.

Refer to the *TG700 TV Signal Generator Platform User Manual* for a detailed explanation of the front-panel buttons and the LCD display.

Operating Procedure

After the module is installed in the mainframe, and the mainframe is installed in the rack or other location where it will be used, access each function of the module with the following procedure:

1. Connect the power connector on the rear panel to the AC electric power source using the power cord.

Electric power is supplied to the mainframe.

2. Wait until the power up initialization process is complete, and check that no error messages appear on the display.
3. Following the initialization process the mainframe main menu appears, as shown below.



TG700: PRESET

4. Press the front-panel **MODULE** button until the HDVG7 module main menu appears, as shown below.

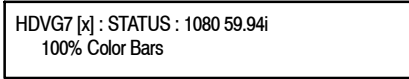

HDVG7 [x]: STATUS: 1080 59.94i
100% Color Bars

5. Select the signal format and the signal you want to output. Refer to *Selecting an Output Signal* on page 2-2 for more information.
6. Press the front-panel arrow buttons to select the desired main menu item or submenu.

Refer to *HDVG7 Module Main Menu* beginning on page 2-4 for detailed information about the main menu items and the submenu items.

Selecting an Output Signal

When you output a signal from the HDVG7 Generator module, you need to select a signal format and output signal. This subsection provides instructions on how to output a signal.

Selecting a Format

If you press the front-panel **FORMAT** button when the HDVG7 Generator module is selected (active), you can select the format for the output signals.

Perform the following steps to select the format:

1. Confirm that any menu item of the HDVG7 module main menu is displayed. If the menu is not displayed, press the front-panel **MODULE** button until the HDVG7 module main menu appears, as shown below.



```
HDVG7 [x] : STATUS : 1080 59.94i
100% Color Bars
```

2. Press the **FORMAT** button. The menu display changes as follows:

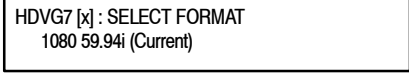

```
HDVG7 [x] : SELECT FORMAT
1080 59.94i (Current)
```

3. Press the left (◀) or right (▶) arrow button to select one of the signal formats, and then press the **ENTER** button to confirm the selection.

NOTE. When you change signal format, synchronization shock occurs.

Selecting a Signal

All signal sets available in the module are already assigned to the corresponding test signal buttons (see Figure 2-1). When you press any of the buttons, one of the signals in the signal set is output.

For example, when you press the **COLOR BAR** test signal button, you can output the **100% Color Bars** signal in the Color Bars signal set.

Press the left (◀) or right (▶) arrow button, or press the test signal button repeatedly to select different signals assigned to the test signal button.

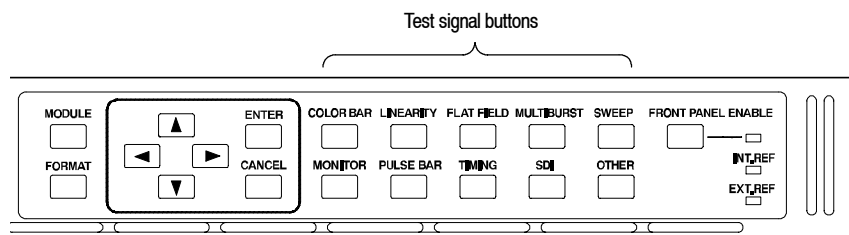

Figure 2-1: Front-panel test signal buttons

Table 2-1 lists the signal set assigned to each test signal button and the signals that can be selected in the signal set.

Table 2-1: Signal set assigned to the test signal buttons

Button name	Signal set	Signals in the signal set
COLOR BAR	Color Bars	100% Color Bars, 75% Color Bars, SMPTE Color Bars
LINEARITY	Linearity	5 Step Staircase, Limit Ramp, Ramp, Shallow Ramp Matrix, Shallow Ramp Valid Ramp
FLAT FIELD	Flat Fields	0% Flat Field, 50% Flat Field, 100% Flat Field
MULTI BURST	Multi Burst	Multiburst 1-10 MHz, Multiburst 10-20 MHz, Multiburst 20-30 MHz
SWEEP	Sweep	100% Sweep 1-15 MHz, 100% Sweep 1-30 MHz
MONITOR	Monitor	75% Blue Field, 75% Green Field, 75% Red Field, Convergence
PULSE BAR	Pulse & Bar	2T30 Pulse and Bar
TIMING	Timing	Bowtie 1ns Markers, Co-site Pulse
SDI	SDI Test	Equalizer Test, PLL Test, SDI Matrix
OTHER	-----	-----

If you want to output custom signals from the module, you need to assign the signal set to any of the test signal buttons. Refer to *TG700 TV Signal Generator Platform User Manual* for detailed information about how to assign a signal set to a test signal button.

HDVG7 Module Main Menu

You can set the logo, circle, and text overlay, embedded audio, timing offset of the serial digital signal outputs using the HDVG7 module main menu.

Use the up (▲) or down (▼) arrow button to scroll through the main menu. Figure 2-2 shows the HDVG7 module main menu.

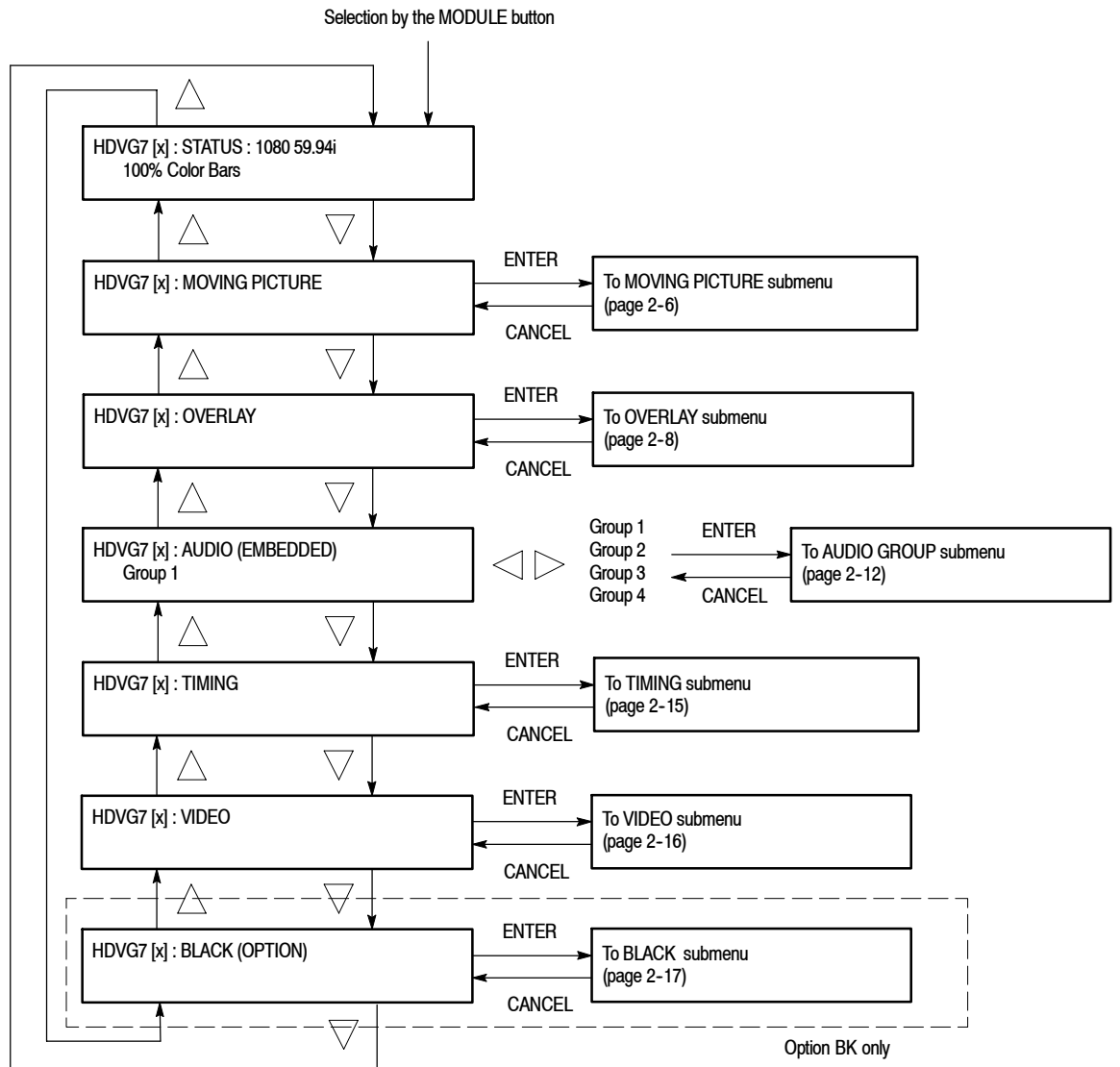

Figure 2-2: HDVG7 module main menu

MOVING PICTURE. Scrolls the active picture area of the output test signal. When you select this menu item and then press the ENTER button, you will access the MOVING PICTURE submenu. Refer to *MOVING PICTURE Submenu* on page 2-6 for detailed information.

OVERLAY. Selects an item (logo, text, or circle) that is overlaid on the output test signal and sets the blinking mode for the overlay. When you select this menu item and then press the ENTER button, you will access the OVERLAY submenu. Refer to *OVERLAY Submenu* on page 2-7 for detailed information.

AUDIO (EMBEDDED). Sets the parameters for embedded audio on the output test signals. Use the left (◀) or right (▶) arrow button to select **Group 1**, **Group 2**, **Group 3**, or **Group 4**. When you select any of the items and then press the ENTER button, you will access the AUDIO GROUP submenu. Refer to *AUDIO GROUP Submenu* on page 2-12 for detailed information.

TIMING. Sets the timing offset of the serial digital video outputs relative to the internal reference signal (frame reset signal). When you select this menu item and then press the ENTER button, you will access the TIMING submenu. Refer to *TIMING Submenu* on page 2-15 for detailed information.

VIDEO. Enables or disables the Y, Pb, or Pr component of the output serial digital video signals and the output mode for an audio/video timing measurement. When you select this menu item and then press the ENTER button, you will access the VIDEO submenu. Refer to *VIDEO Submenu* on page 2-16 for detailed information.

BLACK (OPTION). This menu is only available Option BK, and sets the parameters of the serial digital black signals output from the **BLACK 1** and **BLACK 2** connectors. When you select this menu item and then press the ENTER button, you will access the BLACK submenu. Refer to *BLACK Submenu* on page 2-17 for detailed information.

**MOVING PICTURE
Submenu**

This menu allows you to scroll the active picture area of the serial digital video signal up/down or left/right (or randomly). Use the up (▲) or down (▼) arrow button to scroll through the menu. Figure 2-3 shows the MOVING PICTURE submenu.

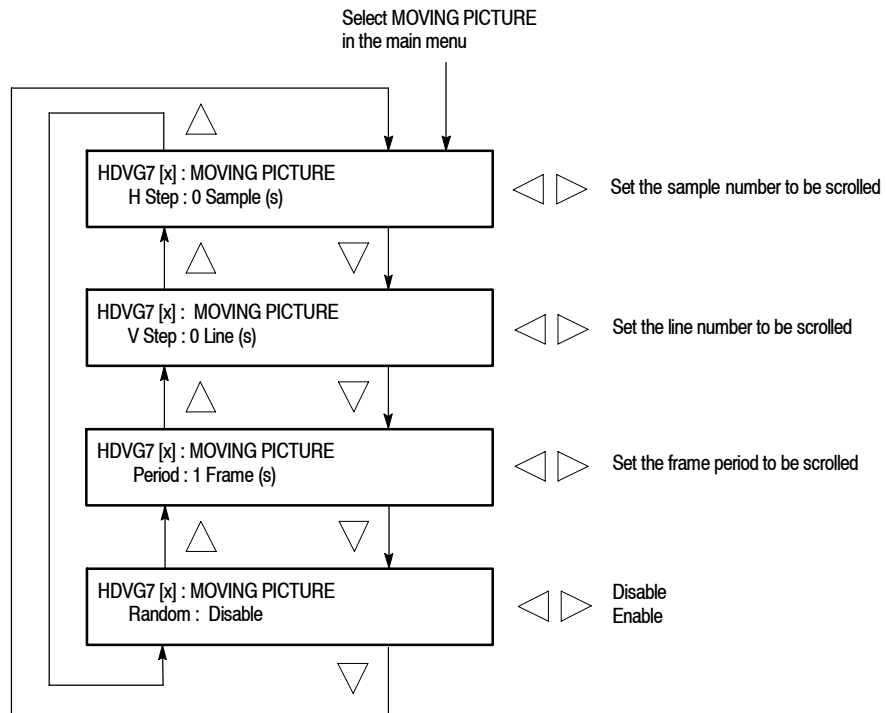

Figure 2-3: MOVING PICTURE submenu

- **H Step:** Sets the number of samples to be scrolled per frame set in the **Period** menu item. Use the left (◀) or right (▶) arrow button to change the value. You can set the value from -252 to +252 in 4 samples steps.
- **V Step:** Sets the number of lines to be scrolled per frame set in the **Period** menu item. Use the left (◀) or right (▶) arrow button to change the value. You can set the value from -252 to +252 in 1 line steps.
- **Period:** Sets the time interval between occurrences of the scrolling. Use the left (◀) or right (▶) arrow button to change the value. You can set the value from 1 to 16 in 1 frame steps.
- **Random:** Sets whether or not the picture scrolls randomly. Use the left (◀) or right (▶) arrow button to select between **Disable** and **Enable**. Press the **ENTER** button to confirm the selection.

OVERLAY Submenu

This menu allows you to select an item (logo, ID Text, or circle) to overlay on the output test signal, and to set the blinking mode for the overlay. Use the up (▲) or down (▼) arrow button to scroll through the menu. Figure 2-4 shows the OVERLAY submenu.

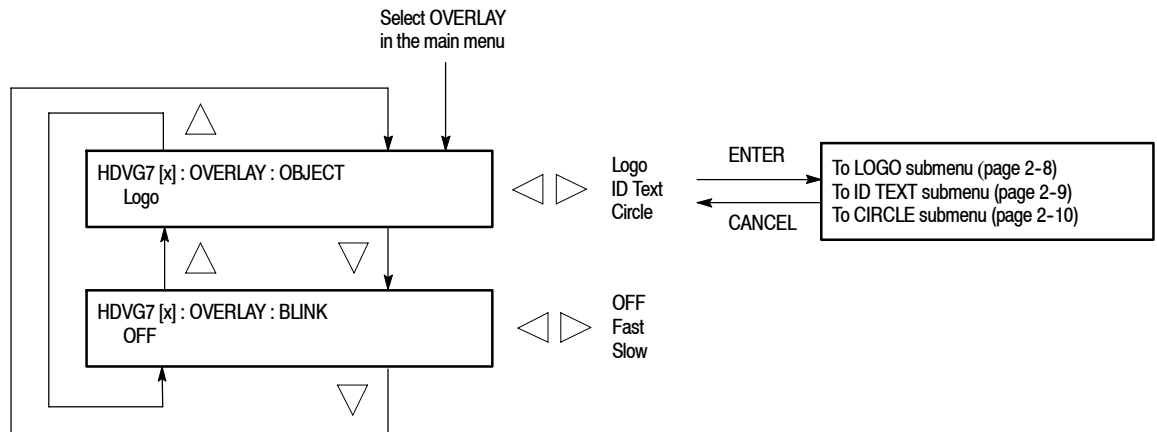

Figure 2-4: OVERLAY submenu

- **OBJECT:** Selects an item that is overlaid on the output test signal. Use the left (◀) or right (▶) arrow button to select **Logo**, **ID Text**, or **Circle**. When you select any of these items and then press the ENTER button, you will access the submenu for setting that overlay. Refer to *LOGO Submenu* on page 2-8, *ID TEXT Submenu* on page 2-9, or *CIRCLE Submenu* on page 2-10 for detailed information.
- **BLINK:** Sets the blinking mode for the overlay. Use the left (◀) or right (▶) arrow button to select **OFF**, **Fast** (blinks approximately at 0.5 second interval), or **Slow** (blinks approximately at 1.0 interval). Press the **ENTER** button to confirm the selection.

LOGO Submenu

This menu allows you to select a logo to overlay on the output test signal, and to set the display position of the logo. Use the up (▲) or down (▼) arrow button to scroll through the menu. Figure 2-5 shows the LOGO submenu.

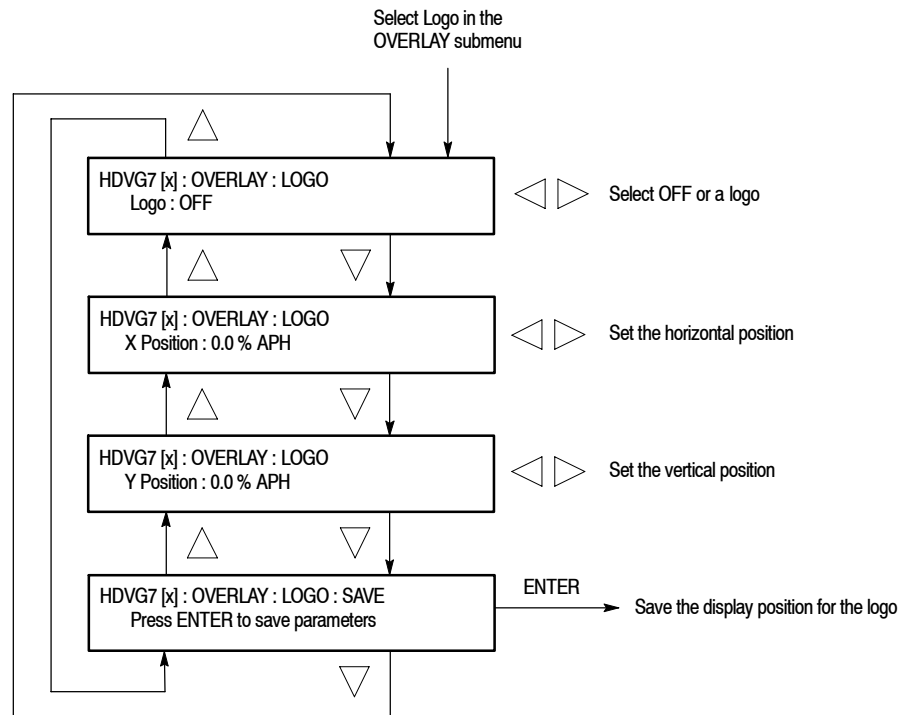

Figure 2-5: LOGO submenu

- **Logo:** Selects the logo you want to display. Use the left (◀) or right (▶) arrow button to select **OFF** or a logo file name. Press the **ENTER** button confirm the selection. When you select OFF, the logo overlay is disabled.
- **X Position:** Sets the horizontal position of the logo. The position is set as a percentage of active picture width. Use the left (◀) or right (▶) arrow button to change the position. You can set the value from -100.0 % to 0.0 % in 0.1% steps.
- **Y Position:** Sets the vertical position of the logo. The position is set as a percentage of active picture height. Use the left (◀) or right (▶) arrow button to change the position. You can set the value from -100.0 % to 0.0 % in 0.1% steps.
- **SAVE:** Saves the display position for the logo to the logo file. Press the **ENTER** button to save the current settings.

In order to display a logo using the LOGO submenu, you need to create the logo file (.lgo) and download it to the LOGO folder of the module.

Refer to the *TG700 TV Signal Generator Platform User Manual* for detailed information about how to create a logo file and download it to the TG700.

ID TEXT Submenu

This menu allows you to edit a text overlaid on the output test signal, and to set the display position of the text. Use the up (▲) or down (▼) arrow button to change the menu items. Figure 2-6 shows the ID TEXT submenu.

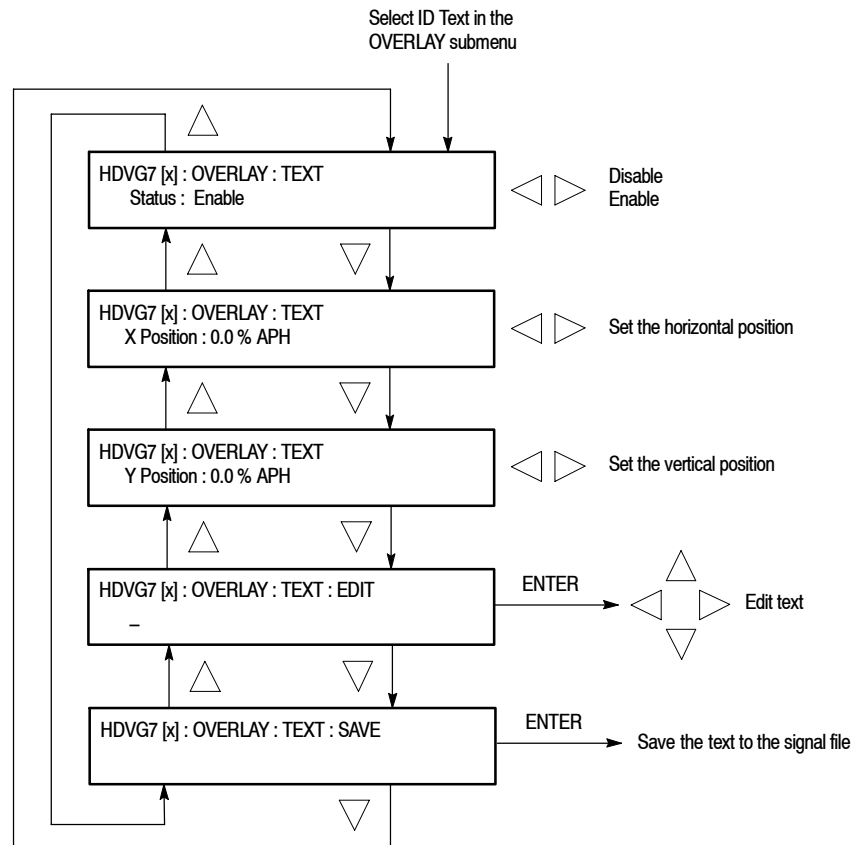

Figure 2-6: ID TEXT submenu

- **Status** : Enables or disables the text overlay. Use the left (◀) or right (▶) arrow button to select between **Enable** and **Disable**. Press the **ENTER** button to confirm the selection.
- **X Position**: Sets the horizontal position of the text. The position is set as a percentage of active picture width. Use the left (◀) or right (▶) arrow button to change the position. You can set the value from 0.0 % to 100.0 % in 1% steps.

- **Y Position:** Sets the vertical position of the text. The position is set as a percentage of active picture height. Use the left (◀) or right (▶) arrow button to change the position. You can set the value from 0.0 % to 100.0 % in 1% steps.
- **EDIT:** Edits the text you want to display on the output test signal.

To edit the text, first press the **ENTER** button to enable the text edit mode. Use the left (◀) or right (▶) arrow button to move the underscore character (_) to the character you want to change, then use the up (▲) or down (▼) arrow button to select the desired character. When you have entered all of the desired characters, press the **ENTER** button to end the text editing process. You can use up to 30 characters for the text. Use the blank character to erase an unneeded character(s).

- **SAVE:** Saves the text and its position to the signal file currently being output. Press the **ENTER** button to save the text and its position to the signal file.

CIRCLE Submenu

This menu allows you to create a circle overlaid on the output test signal and set the display position of the circle. Use the up (▲) or down (▼) arrow button to change the menu items. Figure 2-7 shows the CIRCLE submenu.

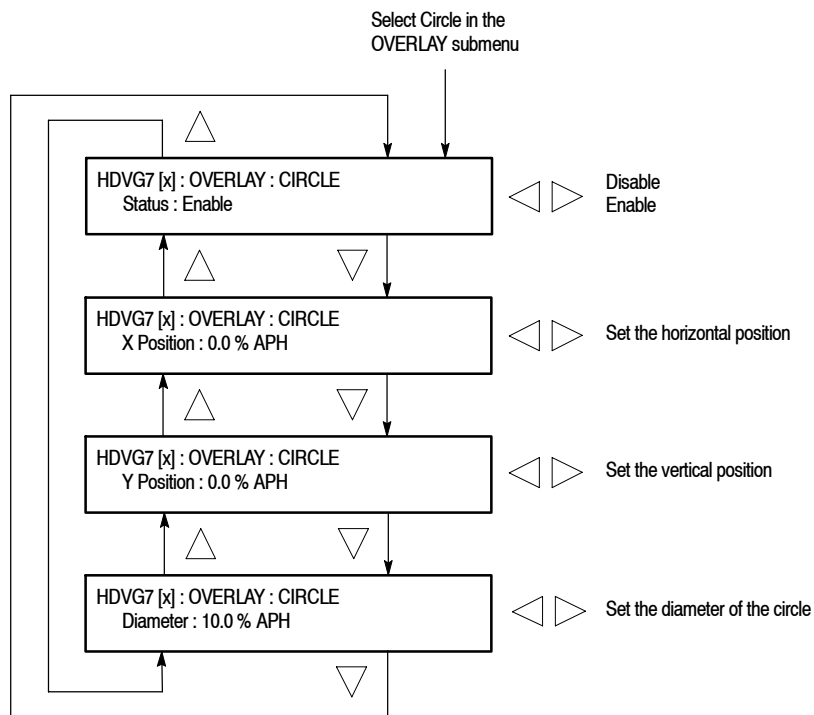

Figure 2- 7: CIRCLE submenu

- **Status** : Enables or disables the circle overlay. Use the left (◀) or right (▶) arrow button to select between **Enable** and **Disable**. Press the **ENTER** button to confirm the selection.
- **X Position**: Sets the horizontal position of the circle. The position is set as a percentage of active picture width. Use the left (◀) or right (▶) arrow button to change the position. You can set the value from -50.0 % to 50.0 % in 1% steps.
- **Y Position**: Sets the vertical position of the circle. The position is set as a percentage of active picture height. Use the left (◀) or right (▶) arrow button to change the position. You can set the value from -50.0 % to 50.0 % in 1% steps.
- **Diameter**: Sets the diameter of the circle. The diameter is set as a percentage of active picture height. Use the left (◀) or right (▶) arrow button to change the value. You can set the value from 0.0 % to 100.0 % in 1% steps.

AUDIO GROUP Submenu

This menu allows you to enable or disable embedded audio of the selected audio group, select which audio channel to enable, and set the emphasis status bits, sampling alignment status bits, and sample bits of the selected audio group. Use the up (▲) or down (▼) arrow button to change the menu items. Figure 2-8 shows the AUDIO GROUP submenu.

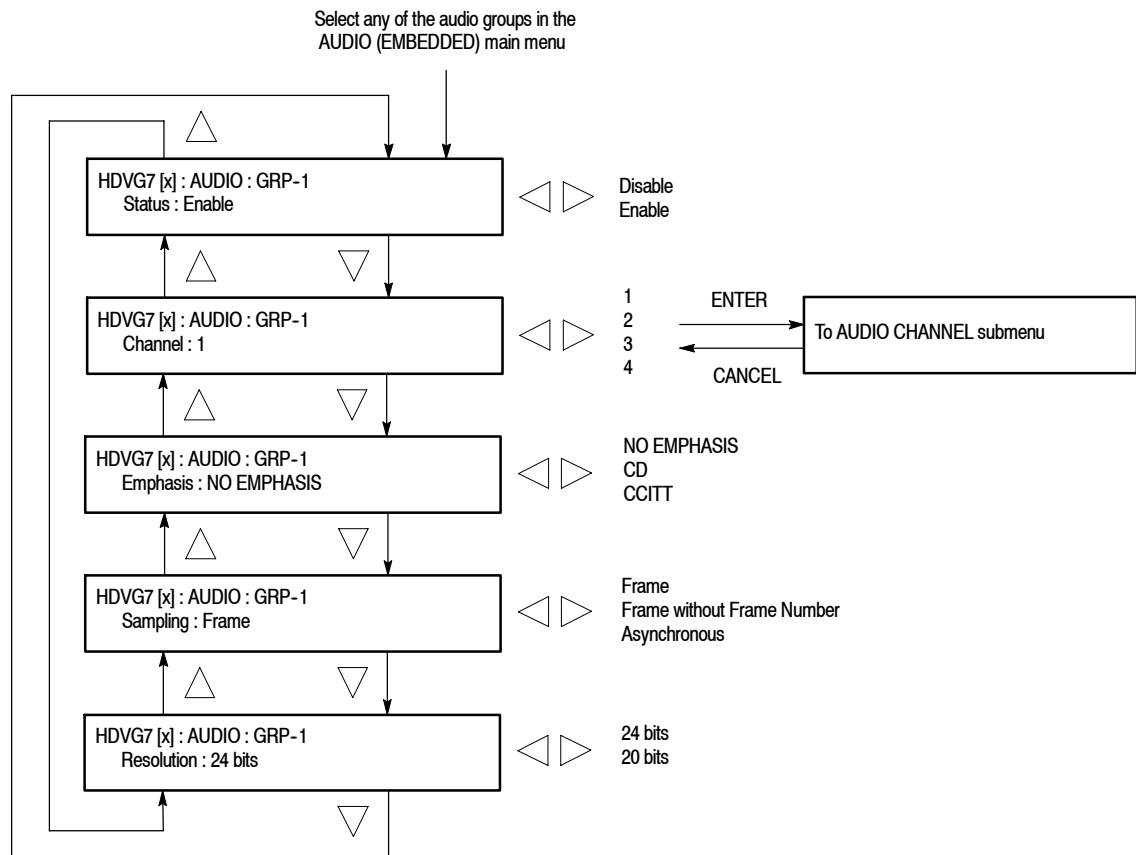

Figure 2-8: AUDIO GROUP submenu

- **Status** : Enables or disables the generation of embedded audio for the selected audio group. Use the left (◀) or right (▶) arrow button to select between **Enable** and **Disable**. Press the **ENTER** button to confirm the selection.
- **Channel**: Selects the channel you want to change the parameters. Use the left (◀) or right (▶) arrow button to select **1**, **2**, **3**, or **4**. When you select any of the channels and then press the **ENTER** button to access the **AUDIO CHANNEL** submenu. Refer to *AUDIO CHANNEL Submenu* on page 2-13 for detailed information about the menu.

- **Emphasis:** Sets the emphasis status bits for the selected audio group. Use the left (◀) or right (▶) arrow button to select **NO EMPHASIS**, **CD**, or **CCITT**. Press the **ENTER** button to confirm the selection.
- **Sampling:** Sets the sampling alignment status bits for the selected audio group. Use the left (◀) or right (▶) arrow button to select **Frame**, **Frame without Frame Number**, or **Asynchronous**. Press the **ENTER** button to confirm the selection.
- **Resolution:** Sets the resolution of the audio signal data for the selected audio group. Use the left (◀) or right (▶) arrow button to select between **24 bits** and **20 bits**. Press the **ENTER** button to confirm the selection.

AUDIO CHANNEL Submenu

This menu allows you to set the frequency, amplitude, and audio click of the embedded audio signal for the selected audio channel. Use the up (▲) or down (▼) arrow button to scroll through the menu. Figure 2-9 shows the AUDIO CHANNEL submenu.

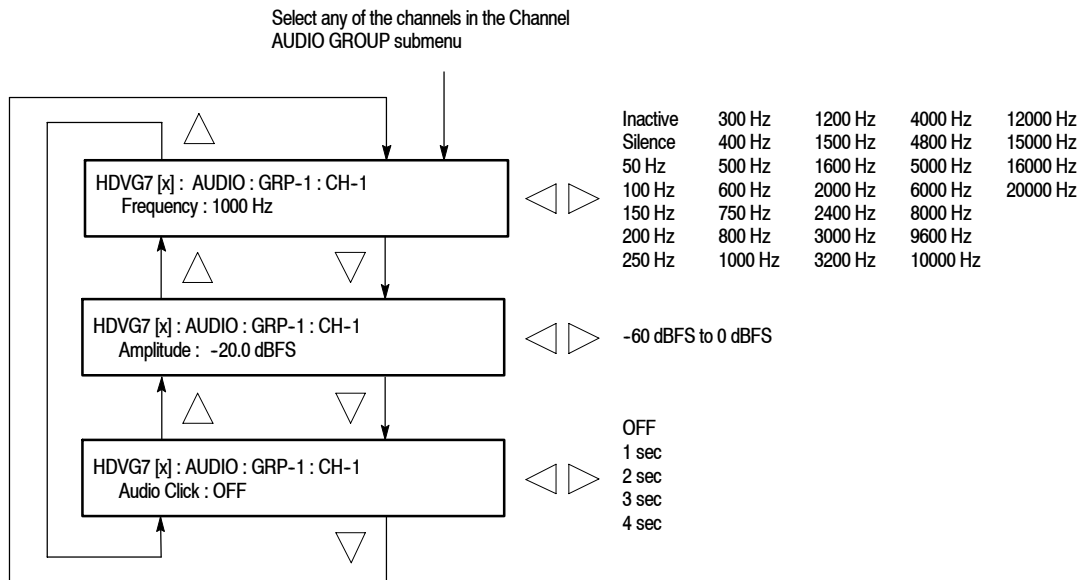

Figure 2-9: AUDIO CHANNEL submenu

- **Frequency** : Sets the audio signal frequency of the selected audio channel. Use the left (◀) or right (▶) arrow button to select the frequency. The selection items are as follows:

Inactive	400 Hz	1600 Hz	6000 Hz
Silence	500 Hz	2000 Hz	8000 Hz
50 Hz	600 Hz	24000 Hz	9600 Hz
100 Hz	750 Hz	3000 Hz	10000 Hz
150 Hz	800 Hz	3200 Hz	12000 Hz
200 Hz	1000 Hz	4000 Hz	15000 Hz
250 Hz	1200 Hz	4800 Hz	16000 Hz
300 Hz	1500 Hz	5000 Hz	20000 Hz

When **Inactive** is selected, the audio data output is disabled. Press the **ENTER** button to confirm the selection.

- **Amplitude** : Sets the audio signal amplitude of the selected audio channel. Use the left (◀) or right (▶) arrow button to set the amplitude. You can set the value from -60 dBFS to 0 dBFS in 1 dBFS steps.
- **Audio Click** : Inserts audio clicks in the selected audio channel. The audio tone, if any, is turned off for an interval around the audio click. Use the left (◀) or right (▶) arrow button to make the selection. The choices are **OFF**, **1 sec**, **2 sec**, **3 sec**, and **4 sec**. Press the **ENTER** button to enable the selection.

Audio Click becomes valid when you select **1 sec** to **4 sec** for the Audio Click rate. When Audio Click is valid, Audio Tone is turned off for 0.25 second around the click. For example, if you select **3 sec** for the click rate the audio tone will be output for 2.75 seconds, and silent for 0.25 second; the click occurs during this silence. When Audio Click is **OFF**, the Audio Tone selected in the **FREQUENCY** menu is output continuously. Audio Click makes it easy to identify any channel(s) of the four output channels.

TIMING Submenu

This menu allows you to adjust the timing offset of the serial digital video outputs relative to the internal reference signal (frame reset signal). Use the up (▲) or down (▼) arrow button to change the menu items. Figure 2-10 shows the TIMING submenu.

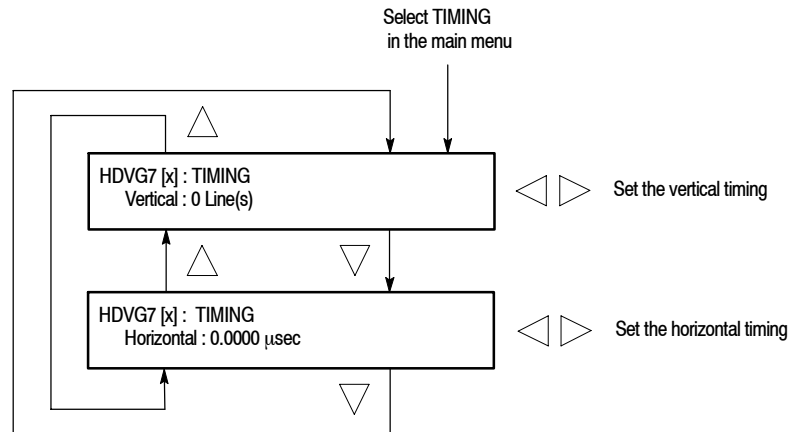

Figure 2- 10: TIMING submenu

- **Vertical:** Sets the vertical timing offset. Use the left (◀) or right (▶) arrow button to change the timing offset. You can set the value from $-1/2$ to $+1/2$ frame in 1-line steps.
- **Horizontal:** Sets the horizontal timing offset. Use the left (◀) or right (▶) arrow button to change the timing offset. You can set the value from -1 to $+1$ line in 1-clock (13.5 ns) steps.

NOTE. You can reset the timing offset to zero by pressing the left (◀) and right (▶) arrow buttons simultaneously.

VIDEO Submenu

This menu allows you to turn the Y, Pb, or Pr component of the serial digital video signals on or off individually. You can also turn the output mode for an audio/video timing measurement on or off. Use the up (▲) or down (▼) arrow button to scroll through the menu. Figure 2-11 shows the VIDEO submenu.

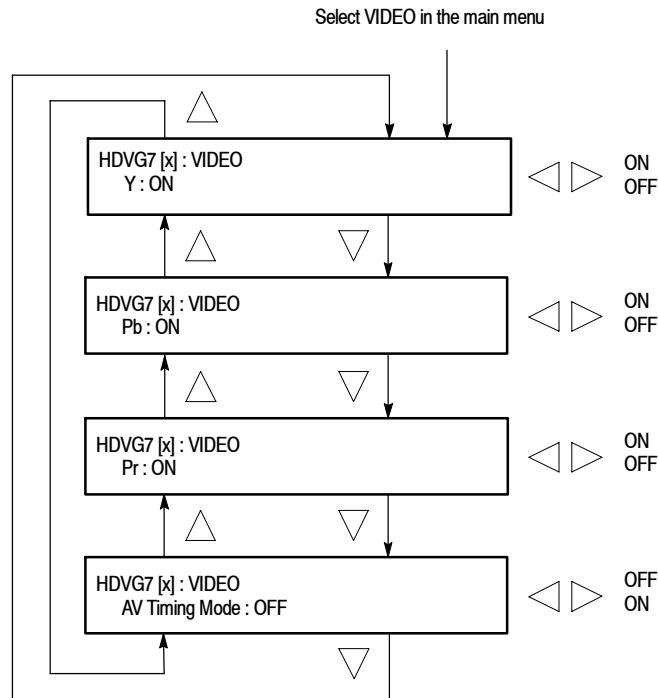

Figure 2- 11: VIDEO submenu

- **Y:** Turns the Y component of the serial digital video signals on or off. Use the left (◀) or right (▶) arrow button to select between **ON** and **OFF**. Press the **ENTER** button to confirm the selection.
- **Pb:** Turns the Pb component of the serial digital video signals on or off. Use the left (◀) or right (▶) arrow button to select between **ON** and **OFF**. Press the **ENTER** button to confirm the selection.
- **Pr:** Turns the Pr component of the serial digital video signals on or off. Use the left (◀) or right (▶) arrow button to select between **ON** and **OFF**. Press the **ENTER** button to confirm the selection.
- **AV Timing Mode:** Turns the output mode for an audio/video timing measurement on or off. Use the left (◀) or right (▶) arrow button to select between **ON** and **OFF**. Press the **ENTER** button to confirm the selection.

When you turn on this mode, the specified audio and video signals are synchronously on for 0.5 second and off for 4.5 seconds. With this signal, you can measure the time delay that accumulates between the audio and video content of the television signal during signal transport. The time delay can be measured by a video analyzer with the serial digital video signal or by an oscilloscope with the analog audio and video signals deembedded from the serial digital video signal. The following settings are recommended for the audio and video signals when you use this mode:

Audio signal (CH1 and CH2 of Group 1) : 10000 Hz, -20 dBFS
 Video signal: 100% Flat Field

NOTE. The AV Timing Mode setting is not saved as a preset.

BLACK Submenu (Option BK Only)

This menu allows you to set the output parameters of the serial digital black signals output from the **BLACK1** and **BLACK 2** connectors. Use the up (▲) or down (▼) arrow button to scroll through the menu. Figure 2-12 shows the BLACK submenu.

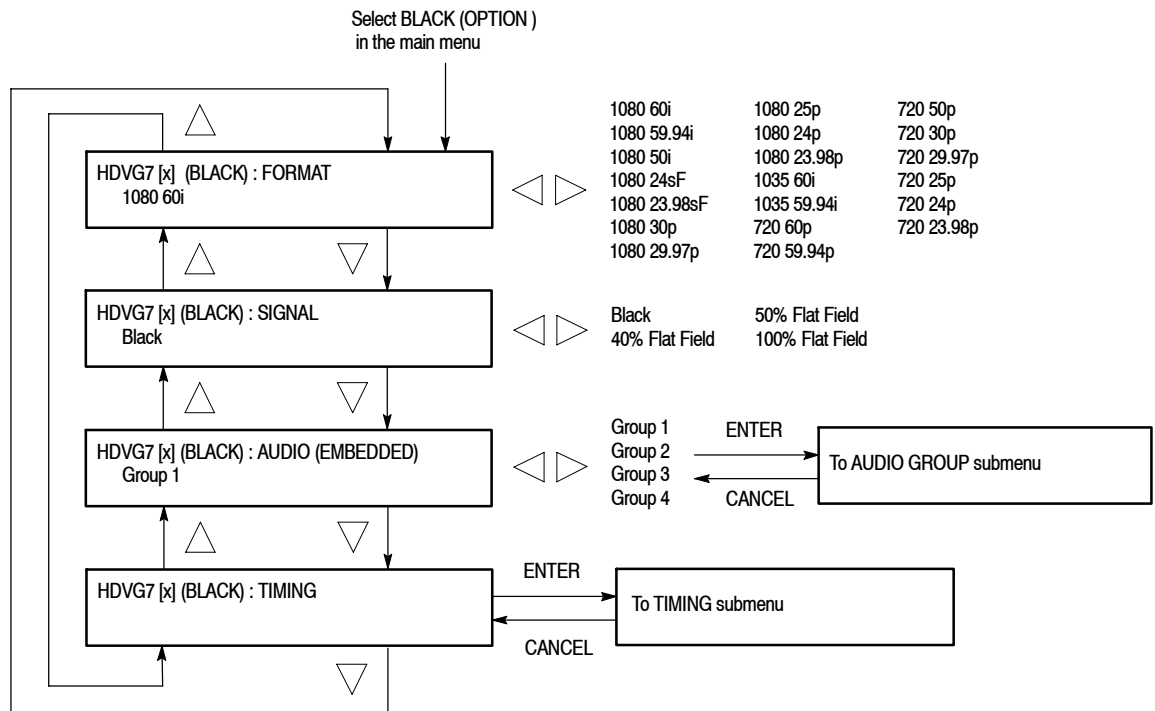

Figure 2-12: BLACK submenu (Option BK only)

FORMAT. Selects the format of the output serial digital black signals. Use the left (◀) or right (▶) arrow button to select **1080 60i, 1080 59.94i, 1080 50i, 1080 24sF, 1080 30p, 1080 29.97p, 1080 25p, 1080 24p, 1080 23.98p, 1035 60i, 1035 59.94i, 720 60p, 720 59.94p, 720 50p, 720 30p, 720 29.97p, 720 25p, 720 24p, or 720 23.98p.** Press the **ENTER** button to confirm the selection.

SIGNAL. Selects the serial digital black signal to output. Use the left (◀) or right (▶) arrow button to select between **Black** (serial digital black), **40% Flat Field**, **50% Flat Field**, and **100% Flat Field**. Press the **ENTER** button to confirm the selection.

AUDIO (EMBEDDED). Sets the parameters for embedded audio on the serial digital black signals. Use the left (◀) or right (▶) arrow button to select **Group 1, Group 2, Group 3, or Group 4.** When you select any of the groups and then press the **ENTER** button, you will access the **AUDIO GROUP** submenu. Refer to *AUDIO GROUP Submenu* on page 2-12 for detailed information.

TIMING. Sets the timing offset of the serial digital black outputs relative to the internal reference signal (frame reset signal). When you select this menu item and then press the **ENTER** button, you will access the **TIMING** submenu. Refer to *TIMING Submenu* on page 2-15 for detailed information.

Rear-Panel Connectors



CAUTION. *If power is applied to the mainframe, be sure to connect a termination(s) to the unused output(s).*

The HDVG7 Generator module is equipped with two connectors, **SIGNAL 1** and **SIGNAL 2**, which will output serial digital test signals. If Option BK is installed there will be two additional connectors, **BLACK 1** and **BLACK 2**, which will output serial digital black signals. Figure 2-13 shows the HDVG7 Generator module rear-panel with all four connectors installed (Option BK).

NOTE. *The SIGNAL 1 and SIGNAL 2 connectors will both output the same test signal, and the BLACK 1 and BLACK 2 connectors will both output the same black signal.*

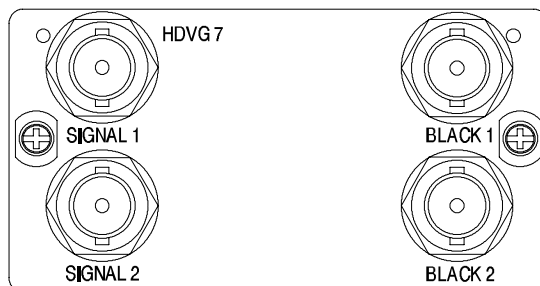

Figure 2-13: HDVG7 module rear-panel connectors (Option BK)

- **SIGNAL 1:** Serial digital test signal output.
- **SIGNAL 2:** Serial digital test signal output.
- **BLACK 1:** Serial digital black output (Option BK only).
- **BLACK 2:** Serial digital black output (Option BK only).

Factory Default Settings

Table 2-2 shows the factory default settings for the HDVG7 Generator module. These settings are recalled when you select **Factory Default** from the **PRESET : RECALL** menu item in the mainframe main menu.

Table 2-2: Factory default settings

Menu item name	Settings
STATUS	1080 59.94i SMPTE Color Bars
MOVING PICTURE	
H Step	0 Sample(s)
V Step	0 Line(s)
Period	1 Frame(s)
Random	Disable
OVERLAY : OBJECT	Logo
OVERLAY : BLINK	OFF
OVERLAY : LOGO	
Logo	OFF
OVERLAY : ID TEXT	
Status	Disable

Table 2-2: Factory default settings (Cont.)

Menu item name	Settings
OVERLAY : CIRCLE	
Status	Disable
X Position	0.0 % APH
Y Position	0.0 % APH
Diameter	90 % APH
AUDIO : GRP-1 to GRP-4	
Status	Disable
Emphasis	No Emphasis
Sampling	Frame
Resolution	24 bits
AUDIO : GRP-1 : Ch-1 to CH-4	
Frequency	1000 Hz
Amplitude	-20.0 dBFS
Audio Click	OFF
TIMING	
Vertical	0 Line(s)
Horizontal	0.0000 μ s
VIDEO	
Y	ON
Pb	ON
Pr	ON
AV Timing Mode	OFF
Option BK	
(BLACK) FORMAT	1080 59.94i
(BLACK) SIGNAL	Black
(BLACK) AUDIO : GRP-1 to GRP-4	
Status	Disable
Emphasis	No Emphasis
Sampling	Frame
Resolution	24 bits
(BLACK) AUDIO : CH-1 to CH-4	
Frequency	1000 Hz
Amplitude	-20.0 dBFS
Audio Click	OFF

Table 2-2: Factory default settings (Cont.)

Menu item name	Settings
(BLACK)TIMING	
Vertical	0 Line(s)
Horizontal	0.0000 μ s



Reference

Syntax

This section contains information on the Standard Commands for Programmable Instruments (SCPI) and the programming structure you can use to program your HDVG7 Generator module.

Programming Model

Specific conditions must exist before programming commands will affect the test signal generated by a module.

Selecting the Module

Select the module using the :INSTRument:SElect command before executing any commands. Many of the commands used by the HDVG7 module are shared by several modules and will be accepted without a reported error.

Command Arguments

Many commands will accept either string or numeric arguments. For example: a boolean argument can either be “1” or “ON”.

Signal parameter commands that have a :STEP node can accept either a numeric value or they can accept a string argument that refers to the :STEP increment.

Signal parameter commands with a :STEP node will accept the following strings in addition to a numeric value:

UP. Use this argument to increase the parameter value one increment as defined by the :STEP value.

DOWN. Use this argument to decrease the parameter value one increment as defined by the :STEP value.

MINimum. Use this argument to set the parameter value to the minimum acceptable value.

MAXimum. Use this argument to set the parameter value to the maximum acceptable value.

DEFault. Use this argument to set the parameter value to the default value.

Query Arguments

If you send a query with no argument, the response is the current value. You can also use **MINimum**, **MAXimum**, and **DEFault** as arguments for queries whose command form can use these arguments (refer to the command syntax for the specific command). Instead of returning the current value, queries using these arguments return the following information:

MINimum. Returns the minimum acceptable value.

MAXimum. Returns the maximum acceptable value.

DEFault. Returns the default value.

Argument Example

The following example demonstrates the effect of each of the arguments when used with a step value.

1. `:INSTRument:SElect "HDVG7:#"` selects the digital video generator module located in the slot number indicated by the “#” symbol.
2. `:OUTPut:CIRClE:STATe ON` displays a circle on the video display.

NOTE. `:OUTPut:CIRClE:DIAMeter` uses an argument that is the percent of picture height.

3. `:OUTPut:CIRClE:DIAMeter DEFaul t` sets the circle diameter to 90 percent of the screen height.
4. `:OUTPut:CIRClE:DIAMeter:STEP 10` sets the step increment to 10 percent.
5. `:OUTPut:CIRClE:DIAMeter DOWN` changes the circle diameter to 80 percent of the screen height.
6. `:OUTPut:CIRClE:DIAMeter 50` changes the circle diameter to 50 percent of the screen height.
7. `:OUTPut:CIRClE:DIAMeter MAXimum` changes the circle diameter to 100 percent of the screen height.
8. `:OUTPut:CIRClE:DIAMeter MINimum` changes the circle diameter to 0 percent of the screen height.
9. `:OUTPut:CIRClE:DIAMeter UP` changes the circle diameter to 10 percent of the screen height.
10. `:OUTPut:CIRClE:DIAMeter? MAXimum` queries the maximum circle diameter (not the current diameter). The query returns the value of 100 percent, which is the maximum circle diameter allowable.

SCPI Commands and Queries

SCPI is a standard created by a consortium that provides guidelines for remote programming of instruments. These guidelines provide a consistent programming environment for instrument control and data transfer. This environment uses defined programming messages, instrument responses, and data format across all SCPI instruments, regardless of manufacturer. The HDVG7 Generator module uses a command language based on the SCPI standard.

The SCPI language is based on a hierarchical or tree structure (see Figure 3-1) that represents a subsystem. The top level of the tree is the root node; it is followed by one or more lower-level nodes.

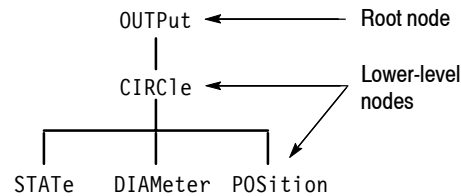

Figure 3-1: Example of SCPI subsystem hierarchy

You can create commands and queries from these subsystem hierarchy trees. Commands specify actions for the instrument to perform. Queries return measurement data and information about parameter settings.

For more information on SCPI commands and programming structure, refer to the *TG700 Signal Generator Platform User Manual*.

Remote Commands

This section describes the remote commands used to control the HDVG7 Generator module remotely. The commands to the module are divided into the following three groups:

- MASS MEMORY commands (Refer to the *TG700 TV Signal Generator Platform User Manual*)
- OUTPUT commands
- SENSE commands

MASS MEMORY Commands

Two MASS MEMORY commands are listed here for your reference. You can use these to load and query the output test signal. Detailed information for using these commands are located in the *TG700 TV Signal Generator Platform User Manual*.

```
:MMEMory:LOAD:SIGNa1 <module_name>,<signal_name>  
:MMEMory:LOAD:SIGNa1 <slot_number>,<signal_name>
```

Loads a signal into the specified module.

```
:MMEMory:SIGNa1:ACTive? <slot_number>|<module_name>
```

Returns the current output signal of the specified module.

OUTPUT Commands

Use these commands control the output parameters of the module. These include embedded audio and circle/text/logo overlay.

Command Tree

```

:OUTPut<n>
  :CIRClE
    :STATe          ON|OFF
    :DIAMeter       <numeric_value>
    :POSition
      :HORizontal   <numeric_value>
      :VERTical     <numeric_value>
  :EAUDio
    :CHANnel<n>
      :AMPLitude    <numeric_value>
      :FREQuency    <numeric_value>
      :CLICK        OFF|1|2|3|4
    :GROup<n>
      :STATe        ON|OFF
      :PREemphasis  OFF|CD|CCITt
      :NBITS        20|24
      :SAMPLIng     FRAMe|NOFRame|ASYNc
  :LOGO
    :STATe          ON|OFF
    :POSition
      :HORizontal   <numeric_value>
      :VERTical     <numeric_value>
    :SElect         <logo_name>
    :SAVE
  :MOVE
    :HORizontal     <numeric_value>
    :VERTical       <numeric_value>
    :PERiod         <numeric_value>
    :RANDom[:STATe] ON|OFF
  :OVERlay
    :BLINK
      :STATe        ON|OFF
      :PERiod       <numeric_value>
  :TEXT
    :STATe          ON|OFF
    :DATA           <string>
    :POSition
      :HORizontal   <numeric_value>
      :VERTical     <numeric_value>
    :SAVE

```

```

:VIDeo
:Y
  :STATe      ON|OFF
:PB
  :STATe      ON|OFF
:PR
  :STATe      ON|OFF
:AVTiming
  :STATe      ON|OFF
:STANdard     HD1080_60I|HD1080_59I|HD1080_50I|
              HD1080_24SF|HD1080_23SF|HD1080_30P|
              HD1080_29P|HD1080_25P|HD1080_24P|
              HD1080_23P|HD1035_60I|HD1035_59I|
              HD720_60P|HD720_59P|HD720_50P|
              HD720_30P|HD720_29P|HD720_25P|
              HD720_24P|HD720_23P
:SIGNal       BLACK|GRAY|FF50P|WHITE

```

Command Description

```
:OUTPut1:CIRClE:STATe ON|OFF
```

Turns the circle overlay on the video signal on or off. You can use 1 or 0 instead of ON or OFF.

```
:OUTPut1:CIRClE:STATe?
```

Returns the current circle overlay state.

```
:OUTPut1:CIRClE:DIAMeter <numeric_value>
```

Sets the diameter of the displayed circle. The unit is percent of active picture height. You can set the diameter from 0 % to 100 % in 1 % steps. You can also use MIN, MAX, or DEF instead of a numeric value.

```
:OUTPut1:CIRClE:DIAMeter?
```

Returns the diameter of the displayed circle.

```
:OUTPut1:CIRClE:POSition:HORizontal <numeric_value>
```

Sets the horizontal position of the circle as it appears on the active signal. The unit is percent of active picture width. You can set the position from -50 % to +50 % in 1 % steps. You can also use MIN, MAX, or DEF instead of a numeric value.

:OUTPut1:CIRClE:POSItion:HORizontal?

Returns the current horizontal position of the circle as it appears on the active signal.

:OUTPut1:CIRClE:POSItion:VERTical <numeric_value>

Sets the vertical position of the circle as it appears on the active signal. The unit is percent of active picture height. You can set the position from -50 % to +50 % in 1 % steps. You can also use MIN, MAX, or DEF instead of a numeric value.

:OUTPut1:CIRClE:POSItion:VERTical?

Returns the current vertical position of the circle as it appears on the active signal.

:OUTPut<n>:EAUDio:CHANnel<m>:AMPLitude <numeric_value>

Sets the amplitude of a specific embedded audio channel for the selected outputs. You can set the amplitude from -60 dBFS to 0 dBFS in 1 dBFS steps. The <n> in the command represents the output connector type. "1" represents the SIGNAL connectors and "2" represents the optional BLACK connectors. The <m> in the command represents the channel number and you can use any channel number from 1 through 16.

:OUTPut<n>:EAUDio:CHANnel<m>:AMPLitude?

Returns the current amplitude of a specific embedded audio channel for the selected outputs. The <n> in the command represents the output connector type. "1" represents the SIGNAL connectors and "2" represents the optional BLACK connectors. The <m> in the command represents the channel number and you can use any channel number from 1 through 16.

:OUTPut<n>:EAUDio:CHANnel<m>:FREQuency <numeric_value>

Sets the frequency of a specific embedded audio channel for the selected outputs. The frequency choices are -1, 0, 50, 100, 150, 200, 250, 300, 400, 500, 600, 750, 800, 1000, 1200, 1500, 1600, 2000, 2400, 3000, 3200, 4000, 4800, 5000, 6000, 8000, 9600, 10000, 12000, 15000, 16000, or 20000. For -1, the output of the audio data is disabled. The <n> in the command represents the output connector type. "1" represents the SIGNAL connectors and "2" represents the optional BLACK connectors. The <m> in the command represents the channel number and you can use any channel number from 1 through 16.

:OUTPut<n>:EAUDio:CHANnel<m>:FREQuency?

Returns the current frequency of a specific embedded audio channel for the selected outputs. The <n> in the command represents the output connector type. “1” represents the SIGNAL connectors and “2” represents the optional BLACK connectors. The <m> in the command represents the channel number and you can use any channel number from 1 through 16.

:OUTPut<n>:EAUDio:CHANnel<m>:CLICk 0|1|2|3|4

Sets the audio click of a specific audio channel for the selected outputs. You can select 0, 1 (second), 2 (seconds), 3 (seconds) or 4 (seconds). When 1, 2, 3 or 4 is selected, the audio click becomes valid. Audio Tone is turned off for 0.25 seconds around the time of the click. The <n> in the command represents the output connector type. “1” represents the SIGNAL connectors and “2” represents the optional BLACK connectors. The <m> in the command represents the channel number and you can use any channel number from 1 through 16.

:OUTPut<n>:EAUDio:CHANnel<m>:CLICk?

Returns the current audio click settings of a specific audio channel for the selected outputs. The <n> in the command represents the output connector type. “1” represents the SIGNAL connectors and “2” represents the optional BLACK connectors. The <m> in the command represents the channel number and you can use any channel number from 1 through 16.

:OUTPut<n>:EAUDio:GRoup<m>:STATe ON|OFF

Turns the output of a specific audio group for the selected outputs on or off. You can also use 1 or 0 instead of ON or OFF. The <n> in the command represents the output connector type. “1” represents the SIGNAL connectors and “2” represents the optional BLACK connectors. The <m> in the command represents the group number and you can use any channel number from 1 through 4.

:OUTPut<n>:EAUDio:GRoup<m>:STATe?

Returns the current output state of a specific audio group for the selected outputs. The <n> in the command represents the output connector type. “1” represents the SIGNAL connectors and “2” represents the optional BLACK connectors. The <m> in the command represents the group number and you can use any channel number from 1 through 4.

`:OUTPut<n>:EAUDio:GROup<m>:PREEmphasis OFF|CD|CCITt`

Turns the preemphasis bits on or off in the audio signal of a specific embedded audio group for the selected outputs. The signal itself does not have preemphasis, but you can set the bits in order to check other equipment. The <n> in the command represents the output connector type. “1” represents the SIGNAL connectors and “2” represents the optional BLACK connectors. The <m> in the command represents the group number and you can use any channel number from 1 through 4.

`:OUTPut<n>:EAUDio:GROup<m>:PREEmphasis?`

Returns the current preemphasis bits settings of a specific embedded audio group for the selected outputs. The <n> in the command represents the output connector type. “1” represents the SIGNAL connectors and “2” represents the optional BLACK connectors. The <m> in the command represents the group number and you can use any channel number from 1 through 4.

`:OUTPut<n>:EAUDio:GROup<m>:NBITs 20|24`

Sets the sample bits of a specific embedded audio group for the selected outputs. The <n> in the command represents the output connector type. “1” represents the SIGNAL connectors and “2” represents the optional BLACK connectors. The <m> in the command represents the group number and you can use any channel number from 1 through 4.

`:OUTPut<n>:EAUDio:GROup<m>:NBITs?`

Returns the current sample bits of a specific embedded audio group for the selected outputs. The <n> in the command represents the output connector type. “1” represents the SIGNAL connectors and “2” represents the optional BLACK connectors. The <m> in the command represents the group number and you can use any channel number from 1 through 4.

`:OUTPut<n>:EAUDio:GROup<m>:SAMPLIng FRAME|NOFRame|ASYNc`

Sets the sampling alignment status bits in the audio signal of a specific embedded audio group for the selected outputs. The <n> in the command represents the output connector type. “1” represents the SIGNAL connectors and “2” represents the optional BLACK connectors. The <m> in the command represents the group number and you can use any channel number from 1 through 4.

:OUTPut<n>:EAUDio:GROup<m>:SAMPLIng?

Returns the current sampling alignment status bits settings of a specific embedded audio group for the selected outputs. The <n> in the command represents the output connector type. “1” represents the SIGNAL connectors and “2” represents the optional BLACK connectors. The <m> in the command represents the group number and you can use any channel number from 1 through 4.

:OUTPut1:LOGO:STATe ON|OFF

Turns the logo overlay display on the video signal on or off. You can also use 1 or 0 instead of ON or OFF.

:OUTPut1:LOGO:STATe?

Returns the current logo overlay state.

:OUTPut1:LOGO:POSition:HORizontal <numeric_value>

Sets the horizontal position of the logo as it appears on the active signal. The unit is percent of active picture width. You can set the position from -100 % to 0 % in 0.1 % steps. You can also use MIN, MAX, or DEF instead of a numeric value.

:OUTPut1:LOGO:POSition:HORizontal?

Returns the current horizontal position of the logo.

:OUTPut1:LOGO:POSition:VERTical <numeric_value>

Sets the vertical position of the logo as it appears on the active signal. The unit is percent of active picture height. You can set the position from -100 % to 0 % in 0.1 % steps. You can also use MIN, MAX, or DEF instead of a numeric value.

:OUTPut1:LOGO:POSition:VERTical?

Returns the current vertical position of the logo.

:OUTPut1:LOGO:SElect <logo_name>

Selects the logo used for the logo overlay.

:OUTPut1:LOGO:SElect?

Returns the current logo used for the logo overlay.

:OUTPut1:LOGO:SAVe

Saves the current display position of the logo to the logo file. There are no arguments.

:OUTPut1:MOVe:HORizontal <numeric_value>

Sets the amount of horizontal scrolling in the moving picture mode. You can set the value from -252 to +252 in 4 samples steps.

:OUTPut1:MOVe:HORizontal?

Returns the amount of horizontal scrolling in the moving picture mode.

:OUTPut1:MOVe:VERTical <numeric_value>

Sets the amount of vertical scrolling in the moving picture mode. You can set the value from -252 to +252 in 1 line steps.

:OUTPut1:MOVe:VERTical?

Returns the amount of vertical scrolling in the moving picture mode.

:OUTPut1:MOVe:PERiod <numeric_value>

Sets the time interval between occurrences of the scrolling. You can set the value from 1 to 16 in 1 field steps.

:OUTPut1:MOVe:PERiod?

Returns the time interval between occurrences of the scrolling.

:OUTPut1:MOVe:RANDom[:STATE] ON|OFF

Turns the random scrolling mode on or off. You can also use 1 or 0 instead of ON or OFF.

:OUTPut1:MOVe:RANDom[:STATE]?

Returns the current state of the random scrolling mode.

:OUTPut1:OVERlay:BLINK:STATE ON|OFF

Turns on or off the blinking mode for the logo, text, and circle overlay. You can also use 1 or 0 instead of ON or OFF

:OUTPut1:OVERlay:BLINK:STATE?

Returns the current state of the blinking mode for the logo, text, and circle overlay.

:OUTPut1:OVERlay:BLINK:PERiod <numeric_value>

Sets the blinking interval of the blinking mode for the logo, text, and circle overlay. You can set the value as 0.5 seconds or 1.0 seconds.

:OUTPut1:OVERlay:BLINK:PERiod?

Returns the blinking interval of the blinking mode for the logo, text, and circle overlay.

:OUTPut1:TEXT:STATe ON|OFF

Turns the text overlay display on the video signal on or off. You can also use 1 or 0 instead of ON or OFF.

:OUTPut1:TEXT:STATe?

Returns the current text overlay state.

:OUTPut1:TEXT:DATA <string>

Sets the current string for the text mode.

:OUTPut1:TEXT:DATA?

Returns the current string for the text mode.

:OUTPut1:TEXT:POSition:HORizontal <numeric_value>

Sets the text horizontal position in the video signal. The unit is percent of active picture width. You can set the position from 0 % to 100 % in 1 % steps. You can also use MIN, MAX, or DEF instead of the numeric value.

:OUTPut1:TEXT:POSition:HORizontal?

Returns the current text horizontal position in the video signal.

:OUTPut1:TEXT:POSition:VERTical <numeric_value>

Sets the text vertical position in the video signal. The unit is percent of active picture height. You can set the position from 0 % to 100 % in 1 % steps. You can also use MIN, MAX, or DEF instead of a numeric value.

:OUTPut1:TEXT:POSition:VERTical?

Returns the current text vertical position in the video signal.

:OUTPut1:TEXT:SAVe

Saves the current text and its display position to the signal file. There are no arguments.

:OUTPut1:VIDeo:Y:STATe ON|OFF

Turns the Y component of the serial digital video signals on or off. You can also use 1 or 0 instead of ON or OFF.

:OUTPut1:VIDeo:Y:STATe?

Returns the current Y component output state of the serial digital video signals.

:OUTPut1:VIDeo:PB:STATe ON|OFF

Turns the P_B component of the serial digital video signals on or off. You can also use 1 or 0 instead of ON or OFF.

:OUTPut1:VIDeo:PB:STATe?

Returns the current P_B component output state of the serial digital video signals.

:OUTPut1:VIDeo:PR:STATe ON|OFF

Turns the P_R component of the serial digital video signals on or off. You can also use 1 or 0 instead of ON or OFF.

:OUTPut1:VIDeo:PR:STATe?

Returns the current output state of the P_R component of the serial digital video signals.

:OUTPut1:VIDeo:AVTiming:STATe ON|OFF

Turns the output mode for an audio/video timing measurement on or off. Refer to *Operating Basics* for detailed information about the mode. You can also use 1 or 0 instead of ON or OFF.

:OUTPut1:VIDeo:AVTiming:STATe?

Returns the current output mode setting for an audio/video timing measurement.

:OUTPut2:STANdard HD1080_60I|HD1080_59I|HD1080_50I|HD1080_24SF|
 HD1080_23SF|HD1080_30P|HD1080_29P|HD1080_25P|
 HD1080_24P|HD1080_23P|HD1035_60I|HD1035_59I|
 HD720_60P|HD720_59P|HD720P_50P|HD720_30P|
 HD720_29P|HD720_25P|HD720_24P|HD720_23P

Sets the video standard for the serial digital black signals output from the BLACK connectors. The choices are HD 1080_60I to HD720_23P. This command is only available if Option BK is installed.

:OUTPut<n>:STANdard?

Returns the video standard for the selected output. The <n> in the command represents the output connector type. “1” represents the SIGNAL connectors and “2” represents the optional BLACK connectors.

:OUTPut2:SIGNa1 BLACK|GRAY|FF50P|WHITe

Sets the type of the serial digital black signals output from the BLACK connectors. The options are BLACK (serial digital black signal), GRAY (40% flat field signal), FF50P (50% flat field signal), or WHITe (100% flat field signal). This command is only available if Option BK is installed.

:OUTPut2:SIGNa1?

Returns the current serial digital black signals output from the BLACK connectors. This command is only available if Option BK is installed.

:OUTPut:CONFigure?

Returns the availability of serial digital black signal output option (Option BK). “1” indicates that the option is available and “0” indicates that the option is not available.

SENSE Commands

Use these commands to set the timing offset of the SIGNAL outputs and the BLACK outputs (Option BK only) relative to the internal reference signal (frame reset signal).

Refer to *Operating Basics* for detailed information about the setting range.

Command Tree

```
:SENSe<n>
  :CORRection
    :MDELay
      :HORizontal      <numeric_value>
      :STEP            <numeric_value>
      :VERTical        <numeric_value>
      :STEP            <numeric_value>
```

Command Description

`:SENSe<n>:CORRection:MDElay:HORizontal <numeric_value>`

Sets the horizontal timing offset of the selected outputs. The timing resolution is clock-cycles. The units are microseconds. You can use UP, DOWN, or DEF instead of the numeric value. If the argument exceeds the horizontal time value, then the vertical offset is adjusted to accommodate the requested delay. The <n> in the command represents the type of output connector. “1” represents the SIGNAL connectors and “2” represents the BLACK connectors.

`:SENSe<n>:CORRection:MDElay:HORizontal?`

Returns the current horizontal timing offset of the selected outputs. The <n> in the command represents the type of output connector. “1” represents the SIGNAL connectors and “2” represents the BLACK connectors.

`:SENSe<n>:CORRection:MDElay:HORizontal:STEP <numeric_value>`

Sets the step increment used by the UP or DOWN commands. The units are microseconds. You can use MIN, MAX, or DEF instead of a numeric value. The <n> in the command represents the type of output connector. “1” represents the SIGNAL connectors and “2” represents the BLACK connectors.

`:SENSe<n>:CORRection:MDElay:HORizontal:STEP?`

Returns the current step increment. The <n> in the command represents the type of output connector. “1” represents the SIGNAL connectors and “2” represents the BLACK connectors.

`:SENSe<n>:CORRection:MDElay:VERTical <numeric_value>`

Sets the vertical timing offset of the selected outputs. The argument can be a floating point value that is translated into integer lines with a horizontal offset. You can use UP, DOWN, or DEF instead of a numeric value. The <n> in the command represents the type of output connector. “1” represents the SIGNAL connectors and “2” represents the BLACK connectors.

`:SENSe<n>:CORRection:MDElay:VERTical?`

Returns the current vertical timing offset of the selected outputs. The <n> in the command represents the type of output connector. “1” represents the SIGNAL connectors and “2” represents the BLACK connectors.

:SENSe<n>:CORRection:MDELay:VERTical:STEP <numeric_value>

Sets the step increment used by the UP or DOWN commands. You can use MIN, MAX, or DEF instead of a numeric value. The <n> in the command represents the type of output connector. "1" represents the SIGNAL connectors and "2" represents the BLACK connectors.

:SENSe<n>:CORRection:MDELay:VERTical:STEP?

Returns the current step increment. The <n> in the command represents the type of output connector. "1" represents the SIGNAL connectors and "2" represents the BLACK connectors.



Appendices

Appendix A: Specifications

Tables A-1 through A-4 list the electrical and environmental characteristics of the HDVG7 Generator module.

Electrical Characteristics

Table A- 1: Serial digital video signal outputs

Characteristic	Performance requirements	Reference information
Connector	BNC	
Number of outputs	2	SIGNAL 1 and SIGNAL 2
Bit Rate	1.485 Gbps 1.485/1.001 Gbps	
Signal amplitude, typical	800 mV	
Rise and fall times, typical	≤ 270 ps	20% to 80%
Jitter, typical	≤ 135 ps	Alignment jitter
Return loss	≥ 15 dB ≥ 10 dB	5 MHz to 750 MHz 750 MHz to 1.485 GHz

Table A- 2: Serial digital black signal outputs (Option BK only)

Characteristic	Performance requirements	Reference information
Connector	BNC	
Number of outputs	2	BLACK 1 and BLACK 2
Bit Rate	1.485 Gbps 1.485/1.001 Gbps	
Signal amplitude, typical	800 mV	
Rise and fall times, typical	≤ 270 ps	20% to 80%
Jitter, typical	≤ 135 ps	Alignment jitter
Return loss	≥ 15 dB ≥ 10 dB	5 MHz to 750 MHz 750 MHz to 1.485 GHz

Table A-3: Embedded audio

Characteristic	Performance requirements	Reference information
Number of channels	16 channels in 4 groups; 8 AES/EBU audio pairs	
Audio tones		
Frequency	Silence to 20 kHz; 31 discrete settings	
Level	-60 to 0 dBFS in 1 dB steps	
Pre-emphasis		Emphasis status bits can be inserted.

Environmental Characteristics

Table A-4: Environmental characteristics

Characteristic	Description
Temperature	
Operating	0 °C to +50 °C
Non-operating	-20 °C to +60 °C
Relative Humidity	
Operating	20% to 80% (No condensation); Maximum wet-bulb temperature 29.4 °C
Non-operating	5% to 90% (No condensation); Maximum wet-bulb temperature 40.0 °C
Altitude	
Operating	To 4.5 km (15,000 feet) Maximum operating temperature decreases 1 °C each 300 m above 1.5 km.
Non-operating	To 15 km (50,000 feet)
Vibration	
Operating	3.04 m/s ² (0.31 G _{rms}), 5 Hz to 500 Hz, 10 min, three axes
Non-operating	23.3 m/s ² (2.38 G _{rms}), 5 Hz to 500 Hz, 10 min, three axes
Shock	
Non-operating	294 m/s ² (30 G), half-sine, 11 ms duration



Index

Index

A

Accessories
 optional, 1-2
 standard, 1-2
AUDIO CHANNEL submenu, 2-13
Audio click, 2-14
AUDIO GROUP submenu, 2-12

B

BLACK 1 connector, 2-19
BLACK 2 connector, 2-19
Black submenu (Option BK only), 2-17

C

Circle overlay, 2-10
CIRCLE submenu, 2-10
Commands
 Rules for forming, 3-1
 Syntax, 3-1

E

Electrical specifications, A-1
Embedded audio, 1-1, 2-12
Environmental specifications, A-2

F

Factory default settings, 2-19
Functional check, 1-3

H

HDVG7 features, 1-1
HDVG7 module main menu, 2-4
Hierarchy (SCPI), 3-3

I

ID TEXT submenu, 2-9
Installation, 1-3

L

Logo overlay, 2-8
LOGO submenu, 2-8

M

Manuals, Related, iii
MASS MEMORY commands, 3-5
MOVING PICTURE submenu, 2-6

O

Operating procedure, 2-1
Option, 1-2
Optional accessories, 1-2
OUTPUT commands, 3-6
OVERLAY submenu, 2-7

P

Product description, 1-1

R

Rear-panel connectors, 2-18
Related Manuals, iii
Remote commands, 3-5
Rules, Command forming, 3-1

S

SCPI, Subsystem hierarchy tree, 3-3
SCPI commands and queries syntax, 3-3–3-4
SENSE commands, 3-15
SIGNAL 1 connector, 2-19
SIGNAL 2 connector, 2-19
Signal set assigned to the test signal buttons, 2-3
Specifications
 Electrical, A-1
 Environmental, A-2
Standard accessories, 1-2
Syntax, Command, 3-1

T

Text overlay, 2-9
TIMING submenu, 2-15

V

VIDEO submenu, 2-16