

## 600mA Synchronous Step-Down DC/DC Converter + 500mA LDO with Delay Function Voltage Detector

### GENERAL DESCRIPTION

The XCM524 series is a multi combination module IC which comprises of a 600mA driver transistor built-in synchronous step-down DC/DC converter and a high speed, high current LDO regulator with voltage detector function. The device is housed in small USP-12B01 package which is ideally suited for space conscious applications. The DC/DC converter and the LDO blocks are isolated in the package so that noise interference from the DC/DC to the LDO regulator is minimal.

The DC/DC converter block with a built-in 0.42 P-channel MOS driver transistor and 0.52 N-channel MOS switching transistor, designed to allow the use of ceramic capacitors. The DC/DC enables a high efficiency, stable power supply with an output current of 600mA to be configured using only a coil and two capacitors connected externally.

The LDO regulator block is precise, low noise, high ripple rejection, low dropout positive voltage regulators with built-in voltage detector. The LDO is also compatible with low ESR ceramic output capacitors. Good output stability is maintained during load fluctuations due to its excellent transient response. The current limiter's fold back circuit also operates as a short circuit protection for the output current.

The voltage detector block of the contains delay circuit. The delay time can be controlled by an external capacitor.

The detector monitors the input voltage of the voltage regulator.

### APPLICATIONS

- BD, DVD drives
- HDD drives
- Cameras, Video recorders
- Mobile phones, Smart phones
- Various general-purpose power supplies

### FEATURES

#### <DC/DC Converter Block>

Input Voltage Range	: 2.7V ~ 6.0V
Output Voltage Options	: 0.8V ~ 4.0V ( $\pm 2\%$ )
High Efficiency	: 92% (TYP.)
Output Current	: 600mA (MAX.)
Oscillation Frequency	: 1.2MHz, 3.0MHz ( $\pm 15\%$ )
Current Limiter Circuit Built-In	: Constant Current & Latching
Control Methods	: PWM PWM/PFM Auto

\*Performance depends on external components and wiring on PCB wiring.

#### <Regulator Block>

Maximum Output Current	: 500mA (Limiter 600mA TYP.) (2.5V $V_{ROUT}$ 4.9V)
Dropout Voltage	: 200mV@ $I_{ROUT}=100mA$ (TYP.)
Operating Voltage Range	: 2.0V ~ 6.0V
Output Voltage Options	: 0.9V ~ 5.1V (0.1V increments, $\pm 2\%$ )
Detect Voltage Options	: 2.0V ~ 5.5V (0.1V increments, $\pm 2\%$ )
VR.VD Temperature Stability	: $\pm 100ppm/$ (TYP.)
High Ripple Rejection	: 65dB (@10kHz)
Low ESR Capacitor	: Ceramic Capacitor
Operating Temperature Range	: -40 ~ +85
Package	: USP-12B01
Environmentally Friendly	: EU RoHS Compliant, Pb Free

### TYPICAL APPLICATION CIRCUIT

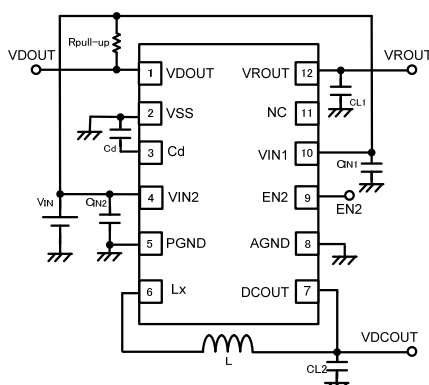

(TOP VIEW)

## PIN CONFIGURATION

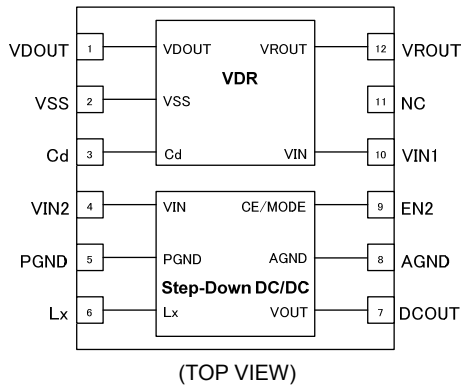

PIN No	XCM524	VDR	DC/DC
1	V <sub>DOUT</sub>	V <sub>DOUT</sub>	-
2	V <sub>SS</sub>	V <sub>SS</sub>	-
3	C <sub>d</sub>	C <sub>d</sub>	-
4	V <sub>IN2</sub>	-	V <sub>IN</sub>
5	PGND	-	PGND
6	L <sub>x</sub>	-	L <sub>x</sub>
7	DCOUT	-	VOUT
8	AGND	-	AGND
9	EN2	-	CE
10	V <sub>IN1</sub>	V <sub>IN1</sub>	-
11	NC	-	-
12	V <sub>ROUT</sub>	V <sub>ROUT</sub>	-

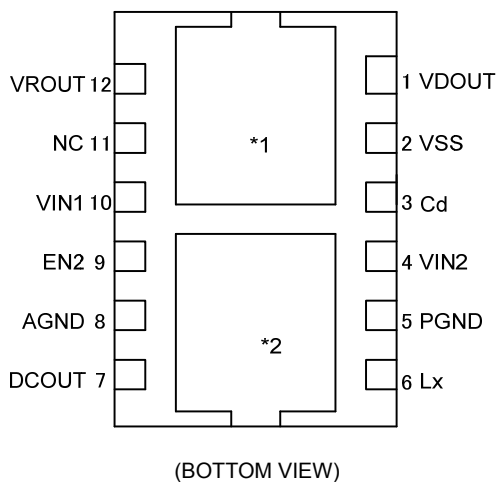

\*DC/DC Ground pin (No.5 and 8) should be short before using the IC.

\* A dissipation pad on the reverse side of the package should be electrically isolated.

\*1: Voltage level of the VDR's dissipation pad should be V<sub>SS</sub> level.

\*2: Voltage level of the DC/DC's dissipation pad should be V<sub>SS</sub> level.

Care must be taken for an electrical potential of each dissipation pad so as to enhance mounting strength and heat release when the pad needs to be connected to the circuit.

## PIN ASSIGNMENT

PIN No	XCM524	FUNCTIONS
1	V <sub>DOUT</sub>	VDR Block: VD Output Voltage
2	V <sub>SS</sub>	VDR Block: Ground
3	C <sub>d</sub>	VDR Block: Delay Capacitor connection
4	V <sub>IN2</sub>	DC/DC Block: Power Input
5	PGND	DC/DC Block: Power Ground
6	L <sub>x</sub>	DC/DC Block: Switching Connection
7	DCOUT	DC/DC Block: Output Voltage
8	AGND	DC/DC Block: Analog Ground
9	EN2	DC/DC Block: ON/OFF Control
10	V <sub>IN1</sub>	VDR Block: Power Input
11	NC	No Connection
12	V <sub>ROUT</sub>	VDR Block: LDO Output

## PRODUCT CLASSIFICATION

### Ordering Information

XCM524A①②③④⑤-⑥<sup>(\*)</sup> DC/DC Block: PWM fixed control

XCM524B①②③④⑤-⑥<sup>(\*)</sup> DC/DC Block: PWM/PFM automatic switching control

DESIGNATOR	DESCRIPTION	SYMBOL	DESCRIPTION
①	Oscillation Frequency and Options	—	See the chart below
②③	Output Voltage	—	See the chart below
④⑤-⑥	Packages Taping Type <sup>(*)</sup>	DR-G	USP-12B01

<sup>(\*)</sup> The XCM524 series is Halogen and Antimony free as well as being fully RoHS compliant.

<sup>(\*)</sup> The device orientation is fixed in its embossed tape pocket.

### DESIGNATOR

①	DC/DC BLOCK			VDR BLOCK		
	OSCILLATION FREQUENCY	C <sub>L</sub> DISCHARGE	SOFT START	VD DELAY FUNCTION	VD SENSE PIN	VD OUTPUT LOGIC
A	1.2M	Not Available	Standard	Available	V <sub>IN</sub>	Active Low Detect
B	3.0M	Not Available	Standard	Available	V <sub>IN</sub>	Active Low Detect
C	1.2M	Available	High Speed	Available	V <sub>IN</sub>	Active Low Detect
D	3.0M	Available	High Speed	Available	V <sub>IN</sub>	Active Low Detect

### DESIGNATOR②③

②③	V <sub>DCOUT</sub>	V <sub>ROUT</sub>	V <sub>DF</sub>
01	1.0	3.3	3.7
02	1.2	3.3	3.7
03	1.5	3.3	3.7
04	1.8	3.3	4.2
05	3.3	1.8	2.8
06	1.8	2.5	2.8

\*This series are semi-custom products. For other combinations of output voltages please consult with your Torex sales contact.

## BLOCK DIAGRAMS

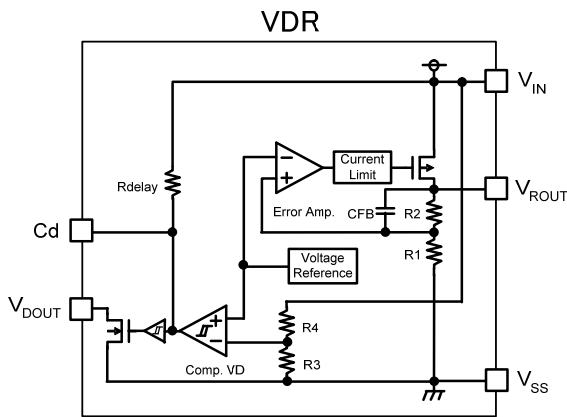

Step-Down DC/DC

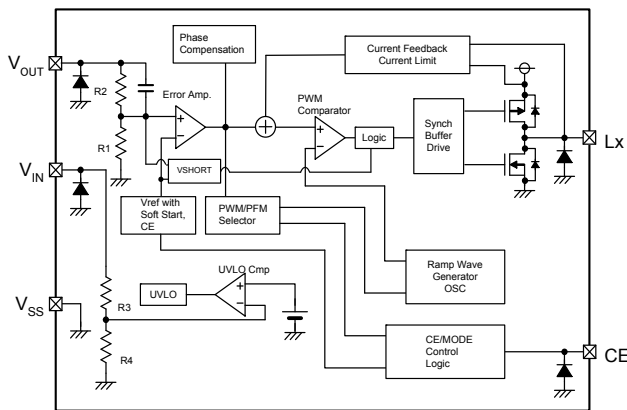

Step-Down DC/DC  
Available with CL Discharge, High Speed Soft-Start

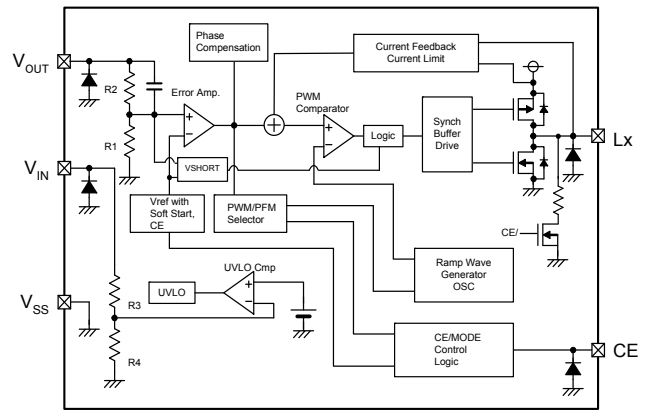

- \* A fixed PWM control scheme because that the "CE Control Logic" outputs a low level signal to the "PWM/PFM Selector".
- \* An auto PWM/PFM switching control scheme because the "CE Control Logic" outputs a high level signal to the "PWM/PFM Selector".
- \* Diodes inside the circuit are an ESD protection diode and a parasitic diode.

## ABSOLUTE MAXIMUM RATINGS

Ta=25

PARAMETER	SYMBOL	RATINGS	UNITS
V <sub>IN1</sub> Voltage	V <sub>IN1</sub>	7.0	V
V <sub>ROUT</sub> Current	I <sub>ROUT</sub>	700 <sup>(*)</sup>	mA
V <sub>ROUT</sub> Voltage	V <sub>ROUT</sub>	V <sub>SS</sub> - 0.3 ~ V <sub>IN1</sub> + 0.3	V
V <sub>DOUT</sub> Current	I <sub>DOUT</sub>	50	mA
V <sub>DOUT</sub> Voltage	V <sub>DOUT</sub>	V <sub>SS</sub> - 0.3 ~ 7.0	V
C <sub>d</sub> Voltage	V <sub>Cd</sub>	V <sub>SS</sub> - 0.3 ~ V <sub>IN1</sub> + 0.3	V
V <sub>IN2</sub> Current	V <sub>IN2</sub>	-0.3 ~ 6.5	V
L <sub>x</sub> Voltage	V <sub>Lx</sub>	-0.3 ~ V <sub>IN2</sub> + 0.3 6.5	V
D <sub>COU</sub> Voltage	V <sub>D<sub>COU</sub></sub>	-0.3 ~ 6.5	V
E <sub>N2</sub> Voltage	V <sub>EN2</sub>	-0.3 ~ 6.5	V
L <sub>x</sub> Current	I <sub>Lx</sub>	± 1500	mA
Power Dissipation	USP-12B01	150	mW
	USP-12B01 (PCB mounted <sup>(*)</sup> )	800 (Only 1ch operation)	
	600 (Both 2ch operation)		
Junction Temperature	T <sub>j</sub>	125	
Operating Temperature Range	T <sub>opr</sub>	- 40 ~ + 85	
Storage Temperature Range	T <sub>stg</sub>	- 55 ~ + 125	

\*1 I<sub>ROUT</sub>= Less than Pd / ( V<sub>IN1</sub>-V<sub>ROUT</sub> )

\*2 The power dissipation figure shown is PCB mounted. Please refer to page 50 for details. Please also note that the power dissipation is for each channel.

## ELECTRICAL CHARACTERISTICS

●XCM524xx 1ch (VDR Block)

Ta=25

	PARAMETER	SYMBOL	CONDITIONS	MIN.	TYP.	MAX.	UNITS	CIRCUIT
VOLTAGE REGULATOR	Output Voltage <sup>(*2, *3)</sup>	$V_{ROUT(E)}$	$I_{ROUT}=30mA$	$\times 0.98$	$V_{ROUT(T)}$	$\times 1.02$	V	
	Maximum Output Current (0.9 ~ 2.4V)	$I_{ROUTMAX}$	$V_{IN1}=V_{ROUT(T)}+2.0V$	400	-	-	mA	
	Maximum Output Current (2.5 ~ 4.9V)	$I_{ROUTMAX}$	$V_{IN1}=V_{ROUT(T)}+2.0V$ Higher than $V_{ROUT(T)}=4.0V, V_{IN1}=6.0V$	500	-	-	mA	
	Load Regulation	$V_{ROUT}$	1mA $I_{ROUT}$ 100mA	-	15	50	mV	
	Dropout Voltage <sup>(*4)</sup>	$V_{dif1}$	$I_{ROUT}=30mA$	E-1			mV	
		$V_{dif2}$	$I_{ROUT}=100mA$	E-2			mV	
	Supply Current (FV / FX / FY / FZ series)	$I_{DD}$	$V_{IN1}=V_{ROUT(T)}+1.0V$ $V_{ROUT(T)} 0.9V, V_{IN1}=2.0V$	-	90	145	$\mu A$	
	Line Regulation	$V_{ROUT}/(V_{IN1} \cdot V_{ROUT})$	$V_{ROUT(T)}+1.0V$ $V_{IN1} 6.0V$ $V_{ROUT(T)} 0.9V, 2.0V$ $V_{IN1} 6.0V$ $I_{ROUT}=30mA$ $V_{ROUT(T)} 1.75V, I_{ROUT}=10mA$	-	0.01	0.20	% / V	
	Input Voltage	$V_{IN1}$		2.0	-	6.0	V	-
	Output Voltage Temperature Characteristics	$V_{ROUT}/(Topr \cdot V_{ROUT})$	$I_{ROUT}=30mA$ -40 $Topr$ 85	-	$\pm 100$	-	ppm /	
	Ripple Rejection Rate	PSRR	$V_{IN1}=[V_{ROUT(T)}+1.0]V+0.5V_{p-pAC}$ When $V_{ROUT(T)} 1.25V,$ $V_{IN1}=2.25V+0.5V_{p-pAC}$ When $V_{ROUT(T)} 4.75V,$ $V_{IN1}=5.75V+0.5V_{p-pAC}$ $I_{ROUT}=50mA, f=10kHz$	-	65	-	dB	
	Current Limiter (2.4V or less)	$I_{RLIM1}$	$V_{IN1}=V_{ROUT(T)}+2.0V$	-	600	-	mA	
	Current Limiter (2.5V or more)	$I_{RLIM}$	$V_{IN1}=V_{ROUT(T)}+2.0V$ Higher than $V_{ROUT(T)}=4.0V, V_{IN1}=6.0V$	500	600	-	mA	
Short-Circuit Current	$I_{RSHORT}$	$V_{IN1}=V_{ROUT(T)}+2.0V$ Higher than $V_{ROUT(T)}=4.0V, V_{IN1}=6.0V$	-	50	-	mA		
VOLTAGE DETECTOR	Detect Voltage <sup>(*7, *8)</sup>	$V_{DF(E)}$		$\times 0.98$	$V_{DF(T)}$	$\times 1.02$	V	
	Hysteresis Range <sup>(*8)</sup>	$V_{HYS}$		$V_{DF(T)}$ $\times 0.02$	$V_{DF(T)}$ $\times 0.05$	$V_{DF(T)}$ $\times 0.08$	V	
	Supply Current <sup>(*9)</sup>	$I_{DOUT}$	$V_{DOUT} = 0.5V$	$V_{IN1} = 2.0V$	3.0	6.0	-	mA
				$V_{IN1} = 3.0V$	4.0	8.0	-	
				$V_{IN1} = 4.0V$	5.0	10.0	-	
				$V_{IN1} = 5.0V$	7.0	12.0	-	
$V_{IN1} = 6.0V$				10.0	15.0	-		
Detect Voltage Temperature Stability	$V_{DF}/(Topr \cdot V_{DF})$	-40 $Topr$ 85	-	$\pm 100$	-	ppm /		
Delay Resistance	$R_{delay}$	$V_{IN1}=6.0V, Cd=0V$ Delay Resistance =6.0V/Delay Current	300	500	700	k $\Omega$		

## NOTE:

\*1 : Unless otherwise stated, ( $V_{IN1}=V_{ROUT(T)}+1.0V$ )\*2 :  $V_{ROUT(T)}$  : Specified VR output voltage\*3 :  $V_{ROUT(E)}$  : Effective VR output voltage. Refer to the E-0 chart for values less than  $V_{DF(T)} 1.5V$ .(i.e. the VR output voltage when "V<sub>ROUT(T)</sub>+1.0V" is provided at the V<sub>IN</sub> pin while maintaining a certain I<sub>ROUT</sub> value).\*4 :  $V_{dif}=\{V_{IN1}^{(*6)}-V_{ROUT1}^{(*5)}\}$ \*5 : A voltage equal to 98% of the VR output voltage whenever a stabilized  $V_{ROUT1}=I_{ROUT}\{V_{ROUT(T)}+1.0V\}$  is input.\*6 :  $V_{IN1}$  : The input voltage when  $V_{OUT1}$ , which appears as input voltage is gradually decreased.\*7 :  $V_{DF(T)}$  : Specified detect voltage value\*8 :  $V_{DF(E)}$  : Effective detect voltage value.

\*9 : VD output current is sink current at detect.

\* The electrical characteristics above are when the other channel is in stop.

## ELECTRICAL CHARACTERISTICS (Continued)

### Dropout Voltage

SYMBOL	E-0		E-1		E-1	
PARAMETER NOMINAL DETECT VOLTAGE OUTPUT VOLTAGE	OUTPUT VOLTAGE DETECT VOLTAGE  (V)		DROPOUT VOLTAGE 1 (mV) (I <sub>OUT</sub> =30mA)  Ta=25		DROPOUT VOLTAGE 2 (mV) (I <sub>OUT</sub> =100mA)  Ta=25	
	V <sub>ROUT(E)</sub> / V <sub>DF(E)</sub>		Vdif1	Vdif1	Vdif2	Vdif2
V <sub>ROUT(T)</sub> V <sub>DF(T)</sub>	MIN.	MAX.	TYP.	MAX.	TYP.	MAX.
0.90	0.870	0.930	1050	1100	1150	1200
1.00	0.970	1.030	1000	1100	1050	1200
1.10	1.070	1.130	900	1000	950	1100
1.20	1.170	1.230	800	900	850	1000
1.30	1.270	1.330	700	800	750	900
1.40	1.370	1.430	600	700	650	800
1.50	1.470	1.530	500	600	550	700
1.60	1.568	1.632	400	500	500	600
1.70	1.666	1.734	300	400	400	500
1.80	1.764	1.836	200	300	300	400
1.90	1.862	1.938	120	150	280	380
2.00	1.960	2.040	80	120	240	350
2.10	2.058	2.142	80	120	240	330
2.20	2.156	2.244	80	120	240	330
2.30	2.254	2.346	80	120	240	310
2.40	2.352	2.448	80	120	240	310
2.50	2.450	2.550	70	100	220	290
2.60	2.548	2.652	70	100	220	290
2.70	2.646	2.754	70	100	220	290
2.80	2.744	2.856	70	100	220	270
2.90	2.842	2.958	70	100	220	270
3.00	2.940	3.060	60	90	200	270
3.10	3.038	3.162	60	90	200	250
3.20	3.136	3.264	60	90	200	250
3.30	3.234	3.366	60	90	200	250
3.40	3.332	3.468	60	90	200	250
3.50	3.430	3.570	60	90	200	250
3.60	3.528	3.672	60	90	200	250
3.70	3.626	3.774	60	90	200	250
3.80	3.724	3.876	60	90	200	250
3.90	3.822	3.978	60	90	200	250
4.00	3.920	4.080	60	80	180	230
4.10	4.018	4.182	60	80	180	230
4.20	4.116	4.284	60	80	180	230
4.30	4.214	4.386	60	80	180	230
4.40	4.312	4.488	60	80	180	230
4.50	4.410	4.590	60	80	180	230
4.60	4.508	4.692	60	80	180	230
4.70	4.606	4.794	60	80	180	230
4.80	4.704	4.896	60	80	180	230
4.90	4.802	4.998	60	80	180	230
5.00	4.900	5.100	50	70	160	210
5.10	4.998	5.202	50	70	160	210
5.20	5.096	5.304				
5.30	5.194	5.406				
5.40	5.292	5.508				
5.50	5.390	5.610				
5.50	5.390	5.610				

## ELECTRICAL CHARACTERISTICS (Continued)

● XCM524xA 2ch (DC/DC Block)

 $V_{DCOUT}=1.8V$ ,  $f_{OSC}=1.2MHz$ ,  $T_a=25^{\circ}C$ 

PARAMETER	SYMBOL	CONDITIONS	MIN.	TYP.	MAX.	UNITS	CIRCUIT
Output Voltage	$V_{DCOUT}$	When connected to external components, $V_{IN2}=V_{EN2}=5.0V, I_{OUT2}=30mA$	1.764	1.800	1.836	V	
Operating Voltage Range	$V_{IN2}$		2.7	-	6.0	V	
Maximum Output Current	$I_{OUT2MAX}$	When connected to external components, $V_{IN2}=V_{DCOUT(T)}+2.0V, V_{EN2}=1.0V$ <sup>(*8)</sup>	600	-	-	mA	
UVLO Voltage	$V_{UVLO}$	$V_{EN2}=V_{IN2}, V_{DCOUT}=0V$ , Voltage which Lx pin holding "L" level <sup>(*1, *10)</sup>	1.00	1.40	1.78	V	
Supply Current	$I_{DD}$	$V_{IN2}=V_{EN2}=5.0V, V_{DCOUT}=V_{DCOUT(T)} \times 1.1V$ (XCM524AA) (XCM524BA)	-	22	50	$\mu A$	
Stand-by Current	$I_{STB}$	$V_{IN2}=5.0V, V_{EN2}=0V, V_{DCOUT}=V_{DCOUT(T)} \times 1.1V$	-	0	1.0	$\mu A$	
Oscillation Frequency	$f_{OSC}$	When connected to external components, $V_{IN2}=V_{DCOUT(T)}+2.0V, V_{EN2}=1.0V, I_{OUT1}=100mA$	1020	1200	1380	kHz	
PFM Switching Current	$I_{PFM}$	When connected to external components, $V_{IN2}=V_{DCOUT(T)}+2.0V, V_{EN2}=V_{IN2}, I_{OUT2}=1mA$ <sup>(*11)</sup>	120	160	200	mA	
PFM Duty Limit	$DTY_{LIMIT\_PFM}$	$V_{EN2}=V_{IN2}=(C-1) I_{OUT2}=1mA$ <sup>(*11)</sup>		200		%	
Maximum Duty Cycle	$D_{MAX}$	$V_{IN2}=V_{EN2}=5.0V, V_{DCOUT}=V_{DCOUT(T)} \times 0.9V$	100	-	-	%	
Minimum Duty Cycle	$D_{MIN}$	$V_{IN2}=V_{EN2}=5.0V, V_{DCOUT}=V_{DCOUT(T)} \times 1.1V$	-	-	0	%	
Efficiency <sup>(*2)</sup>	EFFI	When connected to external components, $V_{EN2}=V_{IN2}=V_{DCOUT(T)}+1.2V$ <sup>(*7)</sup> , $I_{OUT2}=100mA$	-	92	-	%	
Lx SW "H" ON Resistance 1	$R_{LXH1}$	$V_{IN2}=V_{EN2}=5.0V, V_{DCOUT}=0V, I_{LX}=100mA$ <sup>(*3)</sup>	-	0.35	0.55	$\Omega$	
Lx SW "H" ON Resistance 2	$R_{LXH2}$	$V_{IN2}=V_{EN2}=3.6V, V_{DCOUT}=0V, I_{LX}=100mA$ <sup>(*3)</sup>	-	0.42	0.67	$\Omega$	
Lx SW "L" ON Resistance 1	$R_{LXL1}$	$V_{IN2}=V_{EN2}=5.0V$ <sup>(*4)</sup>	-	0.45	0.66	$\Omega$	-
Lx SW "L" ON Resistance 2	$R_{LXL2}$	$V_{IN2}=V_{EN2}=3.6V$ <sup>(*4)</sup>	-	0.52	0.77	$\Omega$	-
Lx SW "H" Leak Current <sup>(*5)</sup>	$I_{LEAKH}$	$V_{IN2}=V_{DCOUT}=5.0V, V_{EN2}=0V, L_X=0V$	-	0.01	1.0	$\mu A$	
Lx SW "L" Leak Current <sup>(*5)</sup>	$I_{LEAKL}$	$V_{IN2}=V_{DCOUT}=5.0V, V_{EN2}=0V, L_X=5.0V$	-	0.01	1.0	$\mu A$	
Current Limit <sup>(*9)</sup>	$I_{LIM}$	$V_{IN2}=V_{EN2}=5.0V, V_{DCOUT}=V_{DCOUT(T)} \times 0.9V$	900	1050	1350	mA	
Output Voltage Temperature Characteristics	$\frac{V_{DCOUT}}{(V_{DCOUT} \cdot T_{opr})}$	$I_{OUT2}=30mA$ -40 Topr 85	-	$\pm 100$	-	ppm/	
EN "H" Voltage	$V_{ENH}$	$V_{DCOUT}=0V$ , Applied voltage to $V_{EN2}$ , Voltage changes Lx to "H" level <sup>(*10)</sup>	0.65	-	6.0	V	
EN "L" Voltage	$V_{ENL}$	$V_{DCOUT}=0V$ , Applied voltage to $V_{EN2}$ , Voltage changes Lx to "L" level <sup>(*10)</sup>	$V_{SS}$	-	0.25	V	
EN "H" Current	$I_{ENH}$	$V_{IN2}=V_{EN2}=5.0V, V_{DCOUT}=0V$	- 0.1	-	0.1	$\mu A$	
EN "L" Current	$I_{ENL}$	$V_{IN2}=5.0V, V_{EN2}=0V, V_{DCOUT}=0V$	- 0.1	-	0.1	$\mu A$	
Soft Start Time	$t_{SS}$	When connected to external components, $V_{EN2}=0V \rightarrow V_{IN2}, I_{OUT1}=1mA$	0.5	1.0	2.5	ms	
Latch Time	$t_{LAT}$	$V_{IN2}=V_{EN2}=5.0V, V_{DCOUT}=0.8 \times V_{DCOUT(T)}$ Short Lx at 1 $\Omega$ resistance <sup>(*6)</sup>	1.0	-	20.0	ms	
Short Protection Threshold Voltage	$V_{SHORT}$	Sweeping $V_{DCOUT}$ , $V_{IN2}=V_{EN2}=5.0V$ , Short Lx at 1 $\Omega$ resistance, DCOUT voltage which Lx becomes "Lx=L" within 1ms	0.675	0.900	1.125	V	

Test conditions: Unless otherwise stated,  $V_{IN2}=5.0V$   $V_{DCOUT(T)}$ = Setting voltage

NOTE:

\*1: Including hysteresis width of operating voltage.

\*2:  $EFFI = \{ ( \text{output voltage} \times \text{output current} ) / ( \text{input voltage} \times \text{input current} ) \} \times 100$ \*3: ON resistance (  $\Omega$  ) =  $( V_{IN2} - Lx \text{ pin measurement voltage} ) / 100mA$ 

\*4: Design value

\*5: When temperature is high, a current of approximately 10  $\mu A$  (maximum) may leak.\*6: Time until it short-circuits DCOUT with GND via 1  $\Omega$  of resistor from an operational state and is set to Lx=0V from current limit pulse generating.\*7:  $V_{DCOUT(T)}+1.2V < 2.7V$ ,  $V_{IN2}=2.7V$ .

\*8: When the difference between the input and the output is small, some cycles may be skipped completely before current maximizes.

If current is further pulled from this state, output voltage will decrease because of P-ch driver ON resistance.

\*9: Current limit denotes the level of detection at peak of coil current.

\*10: "H" =  $V_{IN2} - V_{IN2} - 1.2V$ , "L" =  $+ 0.1V \sim - 0.1V$ \*11: XCM524A series exclude  $I_{PFM}$  and  $DTY_{LIMIT\_PFM}$  because those are only for the PFM control's functions.

\* The electrical characteristics above are when the other channel is in stop.

## ELECTRICAL CHARACTERISTICS (Continued)

●XCM524xB 2ch (DC/DC BLOCK)

$V_{DCOUT}=1.8V, f_{OSC}=3.0MHz, T_a=25^{\circ}C$

PARAMETER	SYMBOL	CONDITIONS	MIN.	TYP.	MAX.	UNITS	CIRCUIT
Output Voltage	$V_{DCOUT}$	When connected to external components, $V_{IN2}=V_{EN2}=5.0V, I_{OUT2}=30mA$	1.764	1.800	1.836	V	
Operating Voltage Range	$V_{IN2}$		2.7	-	6.0	V	
Maximum Output Current	$I_{OUT2MAX}$	When connected to external components, $V_{IN2}=V_{DCOUT(T)}+2.0V, V_{EN1}=1.0V$ <sup>(*8)</sup>	600	-	-	mA	
UVLO Voltage	$V_{UVLO}$	$V_{EN2}=V_{IN2}, V_{DCOUT}=0V,$ Voltage which Lx pin holding "L" level <sup>(*1, *10)</sup>	1.00	1.40	1.78	V	
Supply Current	$I_{DD}$	$V_{IN2}=V_{EN2}=5.0V, V_{DCOUT}=V_{DCOUT(T)} \times 1.1V$ (XCM524AB) (XCM524BB)	-	46	65	$\mu A$	
Stand-by Current	$I_{STB}$	$V_{IN2}=5.0V, V_{EN2}=0V, V_{DCOUT}=V_{DCOUT(T)} \times 1.1V$	-	0	1.0	$\mu A$	
Oscillation Frequency	$f_{OSC}$	When connected to external components, $V_{IN2}=V_{DCOUT(T)}+2.0V, V_{EN2}=1.0V, I_{OUT2}=100mA$	2550	3000	3450	kHz	
PFM Switching Current	$I_{PFM}$	When connected to external components, $V_{IN2}=V_{DCOUT(T)}+2.0V, V_{EN2}=V_{IN2}, I_{OUT2}=1mA$ <sup>(*11)</sup>	170	220	270	mA	
PFM Duty Limit	$DTY_{LIMIT\_PFM}$	$V_{EN2}=V_{IN2}=(C-1) I_{OUT2}=1mA$ <sup>(*11)</sup>		200	300	%	
Maximum Duty Cycle	$D_{MAX}$	$V_{IN2}=V_{EN2}=5.0V, V_{DCOUT}=V_{DCOUT(T)} \times 0.9V$	100	-	-	%	
Minimum Duty Cycle	$D_{MIN}$	$V_{IN2}=V_{EN2}=5.0V, V_{DCOUT}=V_{DCOUT(T)} \times 1.1V$	-	-	0	%	
Efficiency <sup>(*2)</sup>	EFFI	When connected to external components, $V_{EN2}=V_{IN2}=V_{DCOUT(T)}+1.2V$ <sup>(*7), I<sub>OUT2</sub>=100mA</sup>	-	86	-	%	
Lx SW "H" ON Resistance 1	$R_{LXH1}$	$V_{IN2}=V_{EN2}=5.0V, V_{DCOUT}=0V, I_{LX}=100mA$ <sup>(*3)</sup>	-	0.35	0.55	$\Omega$	
Lx SW "H" ON Resistance 2	$R_{LXH2}$	$V_{IN2}=V_{EN2}=3.6V, V_{DCOUT}=0V, I_{LX}=100mA$ <sup>(*3)</sup>	-	0.42	0.67	$\Omega$	
Lx SW "L" ON Resistance 1	$R_{LXL1}$	$V_{IN2}=V_{EN1}=5.0V$ <sup>(*4)</sup>	-	0.45	0.66	$\Omega$	-
Lx SW "L" ON Resistance 2	$R_{LXL2}$	$V_{IN2}=V_{EN1}=3.6V$ <sup>(*4)</sup>	-	0.52	0.77	$\Omega$	-
Lx SW "H" Leak Current <sup>(*5)</sup>	$I_{LEAKH}$	$V_{IN2}=V_{DCOUT}=5.0V, V_{EN2}=0V, L_X=0V$	-	0.01	1.0	$\mu A$	
Lx SW "L" Leak Current <sup>(*5)</sup>	$I_{LEAKL}$	$V_{IN2}=V_{DCOUT}=5.0V, V_{EN2}=0V, L_X=5.0V$	-	0.01	1.0	$\mu A$	
Current Limit <sup>(*9)</sup>	$I_{LIM}$	$V_{IN2}=V_{EN2}=5.0V, V_{DCOUT}=V_{DCOUT(T)} \times 0.9V$	900	1050	1350	mA	
Output Voltage Temperature Characteristics	$V_{DCOUT}/(V_{DCOUT} \cdot T_{opr})$	$I_{OUT2}=30mA$ -40 $T_{opr}$ 85	-	$\pm 100$	-	ppm/	
EN "H" Voltage	$V_{ENH}$	$V_{DCOUT}=0V,$ Applied voltage to $V_{EN2},$ Voltage changes Lx to "H" level <sup>(*10)</sup>	0.65	-	6.0	V	
EN "L" Voltage	$V_{ENL}$	$V_{DCOUT}=0V,$ Applied voltage to $V_{EN2},$ Voltage changes Lx to "L" level <sup>(*10)</sup>	$V_{SS}$	-	0.25	V	
EN "H" Current	$I_{ENH}$	$V_{IN2}=V_{EN2}=5.0V, V_{DCOUT}=0V$	- 0.1	-	0.1	$\mu A$	
EN "L" Current	$I_{ENL}$	$V_{IN2}=5.0V, V_{EN2}=0V, V_{DCOUT}=0V$	- 0.1	-	0.1	$\mu A$	
Soft Start Time	$t_{SS}$	When connected to external components, $V_{EN2}=0V \rightarrow V_{IN2}, I_{OUT2}=1mA$	0.5	0.9	2.5	ms	
Latch Time	$t_{LAT}$	$V_{IN2}=V_{EN2}=5.0V, V_{DCOUT}=0.8 \times V_{DCOUT(T)}$ Short Lx at 1 $\Omega$ resistance <sup>(*6)</sup>	1.0	-	20.0	ms	
Short Protection Threshold Voltage	$V_{SHORT}$	Sweeping $V_{DCOUT}, V_{IN2}=V_{EN2}=5.0V,$ Short Lx at 1 $\Omega$ resistance, DCOUT voltage which Lx becomes "Lx=L" within 1ms	0.675	0.900	1.125	V	

Test conditions: Unless otherwise stated,  $V_{IN2}=5.0V, V_{DCOUT(T)}$ = Setting voltage

NOTE:

\*1: Including hysteresis width of operating voltage.

\*2:  $EFFI = \{ ( \text{output voltage} \times \text{output current} ) / ( \text{input voltage} \times \text{input current} ) \} \times 100$

\*3: ON resistance ( ) =  $(V_{IN2} - Lx \text{ pin measurement voltage}) / 100mA$

\*4: Design value

\*5: When temperature is high, a current of approximately 10  $\mu A$  (maximum) may leak.

\*6: Time until it short-circuits DCOUT with GND via 1 of resistor from an operational state and is set to Lx=0V from current limit pulse generating.

\*7:  $V_{DCOUT(T)}+1.2V < 2.7V, V_{IN2}=2.7V.$

\*8: When the difference between the input and the output is small, some cycles may be skipped completely before current maximizes.

If current is further pulled from this state, output voltage will decrease because of P-ch driver ON resistance.

\*9: Current limit denotes the level of detection at peak of coil current.

\*10: "H" =  $V_{IN2} - V_{IN2} - 1.2V,$  "L" =  $+ 0.1V \sim - 0.1V$

\*11: XCM524A series exclude  $I_{PFM}$  and  $DTY_{LIMIT\_PFM}$  because those are only for the PFM control's functions.

\* The electrical characteristics above are when the other channel is in stop.



## ELECTRICAL CHARACTERISTICS (Continued)

● XCM524xC 2ch (DC/DC BLOCK)

 $V_{DCOUT}=1.8V$ ,  $f_{OSC}=1.2MHz$ ,  $T_a=25^{\circ}C$ 

PARAMETER	SYMBOL	CONDITIONS	MIN.	TYP.	MAX.	UNITS	CIRCUIT
Output Voltage	$V_{DCOUT}$	When connected to external components, $V_{IN2}=V_{EN2}=5.0V, I_{OUT1}=30mA$	1.764	1.800	1.836	V	
Operating Voltage Range	$V_{IN2}$		2.7	-	6.0	V	
Maximum Output Current	$I_{OUT2MAX}$	When connected to external components, $V_{IN2}=V_{DCOUT(T)}+2.0V, V_{EN2}=1.0V$ <sup>(*)</sup>	600	-	-	mA	
UVLO Voltage	$V_{UVLO}$	$V_{EN2}=V_{IN2}$ , $V_{DCOUT}=0V$ , Voltage which Lx pin holding "L" level <sup>(*)</sup> , <sup>(10)</sup>	1.00	1.40	1.78	V	
Supply Current	$I_{DD}$	$V_{IN2}=V_{EN2}=5.0V, V_{DCOUT}=V_{DCOUT(T)} \times 1.1V$ (XCM524AC) (XCM524BC)	-	22 15	50 33	$\mu A$	
Stand-by Current	$I_{STB}$	$V_{IN2}=5.0V, V_{EN2}=0V, V_{DCOUT}=V_{DCOUT(T)} \times 1.1V$	-	0	1.0	$\mu A$	
Oscillation Frequency	$f_{OSC}$	When connected to external components, $V_{IN2}=V_{DCOUT(T)}+2.0V, V_{EN2}=1.0V, I_{OUT2}=100mA$	1020	1200	1380	kHz	
PFM Switching Current	$I_{PFM}$	When connected to external components, $V_{IN2}=V_{DCOUT(T)}+2.0V, V_{EN2}=V_{IN2}, I_{OUT2}=1mA$ <sup>(11)</sup>	120	160	200	mA	
PFM Duty Limit	$DTY_{LIMIT\_PFM}$	$V_{EN2}=V_{IN2}=(C-1)I_{OUT2}=1mA$ <sup>(11)</sup>	-	200	-	%	
Maximum Duty Cycle	$D_{MAX}$	$V_{IN2}=V_{EN2}=5.0V, V_{DCOUT}=V_{DCOUT(T)} \times 0.9V$	100	-	-	%	
Minimum Duty Cycle	$D_{MIN}$	$V_{IN2}=V_{EN2}=5.0V, V_{DCOUT}=V_{DCOUT(T)} \times 1.1V$	-	-	0	%	
Efficiency	EFF1	When connected to external components, $V_{EN2}=V_{IN2}=V_{DCOUT(T)}+1.2V$ <sup>(7)</sup> , $I_{OUT2}=100mA$	-	92	-	%	
Lx SW "H" ON Resistance 1	$R_{LXH1}$	$V_{IN2}=V_{EN2}=5.0V, V_{DCOUT}=0V, I_{LX}=100mA$ <sup>(3)</sup>	-	0.35	0.55	$\Omega$	
Lx SW "H" ON Resistance 2	$R_{LXH2}$	$V_{IN2}=V_{EN2}=3.6V, V_{DCOUT}=0V, I_{LX}=100mA$ <sup>(3)</sup>	-	0.42	0.67	$\Omega$	
Lx SW "L" ON Resistance 1	$R_{LXL1}$	$V_{IN2}=V_{EN2}=5.0V$ <sup>(4)</sup>	-	0.45	0.66	$\Omega$	-
Lx SW "L" ON Resistance 2	$R_{LXL2}$	$V_{IN2}=V_{EN2}=3.6V$ <sup>(4)</sup>	-	0.52	0.77	$\Omega$	-
Lx SW "H" Leak Current <sup>(5)</sup>	$I_{LEAKH}$	$V_{IN1}=V_{DCOUT}=5.0V, V_{EN1}=0V, L_X=0V$	-	0.01	1.0	$\mu A$	
Current Limit <sup>(9)</sup>	$I_{LIM}$	$V_{IN2}=V_{EN2}=5.0V, V_{DCOUT}=V_{DCOUT(T)} \times 0.9V$	900	1050	1350	mA	
Output Voltage Temperature Characteristics	$V_{DCOUT}/(V_{DCOUT} \cdot T_{OPR})$	$I_{OUT2}=30mA$ -40 $T_{OPR}$ 85	-	$\pm 100$	-	ppm/	
EN "H" Voltage	$V_{ENH}$	$V_{DCOUT}=0V$ , Applied voltage to $V_{EN2}$ . Voltage changes Lx to "H" level <sup>(10)</sup>	0.65	-	6.0	V	
EN "L" Voltage	$V_{ENL}$	$V_{DCOUT}=0V$ , Applied voltage to $V_{EN2}$ . Voltage changes Lx to "L" level <sup>(10)</sup>	$V_{SS}$	-	0.25	V	
EN "H" Current	$I_{ENH}$	$V_{IN2}=V_{EN2}=5.0V, V_{DCOUT}=0V$	- 0.1	-	0.1	$\mu A$	
EN "L" Current	$I_{ENL}$	$V_{IN2}=5.0V, V_{EN2}=0V, V_{DCOUT}=0V$	- 0.1	-	0.1	$\mu A$	
Soft Start Time	$t_{SS}$	When connected to external components, $V_{EN2}=0V \rightarrow V_{IN2}, I_{OUT2}=1mA$	-	0.25	0.40	ms	
Latch Time	$t_{LAT}$	$V_{IN2}=V_{EN2}=5.0V, V_{DCOUT}=0.8 \times V_{DCOUT(T)}$ Short Lx at 1 $\Omega$ resistance <sup>(6)</sup>	1.0	-	20	ms	
Short Protection Threshold Voltage	$V_{SHORT}$	Sweeping $V_{DCOUT}$ , $V_{IN2}=V_{EN2}=5.0V$ , Short Lx at 1 $\Omega$ resistance, DCOUT voltage which Lx becomes "Lx=L" within 1ms	0.675	0.900	1.150	V	
$C_L$ Discharge	$R_{DCHG}$	$V_{IN2}=5.0V, L_X=5.0V, V_{EN2}=0V, V_{DCOUT}=open$	200	300	450	$\Omega$	

Test conditions: Unless otherwise stated,  $V_{IN2}=5.0V$   $V_{DCOUT(T)}$ = Setting voltage

NOTE:

\*1: Including hysteresis width of operating voltage.

\*2:  $EFF1 = \{ ( \text{output voltage} \times \text{output current} ) / ( \text{input voltage} \times \text{input current} ) \} \times 100$ \*3: ON resistance (  $\Omega$  ) =  $( V_{IN2} - Lx \text{ pin measurement voltage} ) / 100mA$ 

\*4: Design value

\*5: When temperature is high, a current of approximately 10  $\mu A$  (maximum) may leak.\*6: Time until it short-circuits DCOUT with GND via 1  $\Omega$  of resistor from an operational state and is set to Lx=0V from current limit pulse generating.\*7:  $V_{DCOUT(T)}+1.2V < 2.7V$ ,  $V_{IN2}=2.7V$ .\*8: When the difference between the input and the output is small, some cycles may be skipped completely before current maximizes.  
If current is further pulled from this state, output voltage will decrease because of P-ch driver ON resistance.

\*9: Current limit denotes the level of detection at peak of coil current.

\*10: "H" =  $V_{IN2} - V_{IN2} - 1.2V$ , "L" =  $+ 0.1V \sim - 0.1V$ \*11: XCM524A series exclude  $I_{PFM}$  and  $DTY_{LIMIT\_PFM}$  because those are only for the PFM control's functions.

\* The electrical characteristics above are when the other channel is in stop.

## ELECTRICAL CHARACTERISTICS (Continued)

● XCM524xD 2ch (DC/DC BLOCK)

$V_{DCOUT}=1.8V$ ,  $f_{OSC}=3.0MHz$ ,  $T_a=25^{\circ}C$

PARAMETER	SYMBOL	CONDITIONS	MIN.	TYP.	MAX.	UNITS	CIRCUIT
Output Voltage	$V_{DCOUT}$	When connected to external components, $V_{IN2}=V_{EN2}=5.0V, I_{OUT2}=30mA$	1.764	1.800	1.836	V	
Operating Voltage Range	$V_{IN2}$		2.7	-	6.0	V	
Maximum Output Current	$I_{OUT2MAX}$	When connected to external components, $V_{IN2}=V_{DCOUT(T)}+2.0V, V_{EN2}=1.0V$ <sup>(8)</sup>	600	-	-	mA	
UVLO Voltage	$V_{UVLO}$	$V_{EN2}=V_{IN2}$ , $V_{DCOUT}=0V$ , Voltage which Lx pin holding "L" level <sup>(1, *10)</sup>	1.00	1.40	1.78	V	
Supply Current	$I_{DD}$	$V_{IN2}=V_{EN2}=5.0V, V_{DCOUT}=V_{DCOUT(T)} \times 1.1V$ (XCM524AD) (XCM524BD)	-	46	65	$\mu A$	
Stand-by Current	$I_{STB}$	$V_{IN2}=5.0V, V_{EN2}=0V, V_{DCOUT}=V_{DCOUT(T)} \times 1.1V$	-	0	1.0	$\mu A$	
Oscillation Frequency	$f_{OSC}$	When connected to external components, $V_{IN2}=V_{DCOUT(T)}+2.0V, V_{EN2}=1.0V, I_{OUT2}=100mA$	2550	3000	3450	kHz	
PFM Switching Current	$I_{PFM}$	When connected to external components, $V_{IN2}=V_{DCOUT(T)}+2.0V, V_{EN2}=V_{IN2}, I_{OUT2}=1mA$ <sup>(11)</sup>	170	220	270	mA	
PFM Duty Limit	$DTY_{LIMIT\_PFM}$	$V_{EN2}=V_{IN2}=(C-1)I_{OUT2}=1mA$ <sup>(11)</sup>	-	200	300	%	
Maximum Duty Cycle	$D_{MAX}$	$V_{IN2}=V_{EN2}=5.0V, V_{DCOUT}=V_{DCOUT(T)} \times 0.9V$	100	-	-	%	
Minimum Duty Cycle	$D_{MIN}$	$V_{IN2}=V_{EN2}=5.0V, V_{DCOUT}=V_{DCOUT(T)} \times 1.1V$	-	-	0	%	
Efficiency	EFFI	When connected to external components, $V_{EN2}=V_{IN2}=V_{DCOUT(T)}+1.2V$ <sup>(7)</sup> , $I_{OUT2}=100mA$	-	86	-	%	
Lx SW "H" ON Resistance 1	$R_{LXH1}$	$V_{IN2}=V_{EN2}=5.0V, V_{DCOUT}=0V, I_{LX}=100mA$ <sup>(3)</sup>	-	0.35	0.55	$\Omega$	
Lx SW "H" ON Resistance 2	$R_{LXH2}$	$V_{IN2}=V_{EN2}=3.6V, V_{DCOUT}=0V, I_{LX}=100mA$ <sup>(3)</sup>	-	0.42	0.67	$\Omega$	
Lx SW "L" ON Resistance 1	$R_{LXL1}$	$V_{IN2}=V_{EN2}=5.0V$ <sup>(4)</sup>	-	0.45	0.66	$\Omega$	-
Lx SW "L" ON Resistance 2	$R_{LXL2}$	$V_{IN2}=V_{EN2}=3.6V$ <sup>(4)</sup>	-	0.52	0.77	$\Omega$	-
Lx SW "H" Leak Current <sup>(5)</sup>	$I_{LeakH}$	$V_{IN2}=V_{DCOUT}=5.0V, V_{EN2}=0V, L_X=0V$	-	0.01	1.0	$\mu A$	
Current Limit <sup>(9)</sup>	$I_{LIM}$	$V_{IN2}=V_{EN2}=5.0V, V_{DCOUT}=V_{DCOUT(T)} \times 0.9V$	900	1050	1350	mA	
Output Voltage Temperature Characteristics	$V_{DCOUT}/(V_{DCOUT} \cdot T_{opr})$	$I_{OUT2}=30mA$ -40 $T_{opr}$ 85	-	$\pm 100$	-	ppm/	
EN "H" Voltage	$V_{ENH}$	$V_{DCOUT}=0V$ , Applied voltage to $V_{EN2}$ . Voltage changes Lx to "H" level <sup>(10)</sup>	0.65	-	6.0	V	
EN "L" Voltage	$V_{ENL}$	$V_{DCOUT}=0V$ , Applied voltage to $V_{EN2}$ . Voltage changes Lx to "L" level <sup>(10)</sup>	$V_{SS}$	-	0.25	V	
EN "H" Current	$I_{ENH}$	$V_{IN2}=V_{EN2}=5.0V, V_{DCOUT}=0V$	- 0.1	-	0.1	$\mu A$	
EN "L" Current	$I_{ENL}$	$V_{IN2}=5.0V, V_{EN2}=0V, V_{DCOUT}=0V$	- 0.1	-	0.1	$\mu A$	
Soft Start Time	$t_{SS}$	When connected to external components, $V_{EN2}=0V \rightarrow V_{IN2}, I_{OUT2}=1mA$	-	0.32	0.50	ms	
Latch Time	$t_{LAT}$	$V_{IN2}=V_{EN2}=5.0V, V_{DCOUT}=0.8 \times V_{DCOUT(T)}$ Short Lx at 1 $\Omega$ resistance <sup>(6)</sup>	1.0	-	20	ms	
Short Protection Threshold Voltage	$V_{SHORT}$	Sweeping $V_{DCOUT}$ , $V_{IN2}=V_{EN2}=5.0V$ , Short Lx at 1 $\Omega$ resistance, DCOUT voltage which Lx becomes "L=L" within 1ms	0.675	0.900	1.150	V	
$C_L$ Discharge	$R_{DCHG}$	$V_{IN2}=5.0V, L_X=5.0V, V_{EN2}=0V, V_{DCOUT}=open$	200	300	450	$\Omega$	

Test conditions: Unless otherwise stated,  $V_{IN2}=5.0V$   $V_{DCOUT(T)}$ = Setting voltage

NOTE:

\*1: Including hysteresis width of operating voltage.

\*2:  $EFFI = \{ (output\ voltage \times output\ current) / (input\ voltage \times input\ current) \} \times 100$

\*3: ON resistance ( ) =  $(V_{IN2} - Lx\ pin\ measurement\ voltage) / 100mA$

\*4: Design value

\*5: When temperature is high, a current of approximately 10  $\mu A$  (maximum) may leak.

\*6: Time until it short-circuits DCOUT with GND via 1 of resistor from an operational state and is set to Lx=0V from current limit pulse generating.

\*7:  $V_{DCOUT(T)}+1.2V < 2.7V$ ,  $V_{IN2}=2.7V$ .

\*8: When the difference between the input and the output is small, some cycles may be skipped completely before current maximizes.

If current is further pulled from this state, output voltage will decrease because of P-ch driver ON resistance.

\*9: Current limit denotes the level of detection at peak of coil current.

\*10: "H" =  $V_{IN2} - V_{IN2} - 1.2V$ , "L" =  $+ 0.1V \sim - 0.1V$

\*11: XCM524A series exclude  $I_{PFM}$  and  $DTY_{LIMIT\_PFM}$  because those are only for the PFM control's functions.

\* The electrical characteristics above are when the other channel is in stop.

# ELECTRICAL CHARACTERISTICS (Continued)

PFM Switching Current ( $I_{PFM}$ ) by Oscillation Frequency and Output Voltage

1.2MHz (mA)

SETTING VOLTAGE	MIN.	TYP.	MAX.
$V_{DCOUT(T)} \leq 1.2V$	140	180	240
$1.2V < V_{DCOUT(T)} \leq 1.75V$	130	170	220
$1.8V \leq V_{DCOUT(T)}$	120	160	200

3.0MHz (mA)

SETTING VOLTAGE	MIN.	TYP.	MAX.
$V_{DCOUT(T)} \leq 1.2V$	190	260	350
$1.2V < V_{DCOUT(T)} \leq 1.75V$	180	240	300
$1.8V \leq V_{DCOUT(T)}$	170	220	270

Measuring Maximum  $I_{PFM}$  Limit,  $V_{IN2}$  Voltage

$f_{OSC}$	1.2MHz	3.0MHz
(C-1)	$V_{DCOUT(T)} + 0.5V$	$V_{DCOUT(T)} + 1.0V$

Minimum operating voltage is 2.7V

Although when  $V_{DCOUT(T)} = 1.2V$ ,  $f_{OSC} = 1.2MHz$ , (C-1) = 1.7V the (C-1) becomes 2.7V because of the minimum operating voltage 2.7V.

Soft-Start Time Chart (XCM524xC/ XCM524xD Series Only)

PRODUCT SERIES	$f_{OSC}$	OUTPUT VOLTAGE	MIN.	TYP.	MAX.
XCM524AC	1.2MHz	0.8V $V_{DCOUT(T)} < 1.5V$	-	250 $\mu s$	400 $\mu s$
	1.2MHz	1.5V $V_{DCOUT(T)} < 1.8V$	-	320 $\mu s$	500 $\mu s$
	1.2MHz	1.8V $V_{DCOUT(T)} < 2.5V$	-	250 $\mu s$	400 $\mu s$
	1.2MHz	2.5V $V_{DCOUT(T)} < 4.0V$	-	320 $\mu s$	500 $\mu s$
XCM524BC	1.2MHz	0.8V $V_{DCOUT(T)} < 2.5V$	-	250 $\mu s$	400 $\mu s$
	1.2MHz	2.5V $V_{DCOUT(T)} < 4.0V$	-	320 $\mu s$	500 $\mu s$
XCM524xD	3.0MHz	0.8V $V_{DCOUT(T)} < 1.8V$	-	250 $\mu s$	400 $\mu s$
	3.0MHz	1.8V $V_{DCOUT(T)} < 4.0V$	-	320 $\mu s$	500 $\mu s$

## TYPICAL APPLICATION CIRCUIT

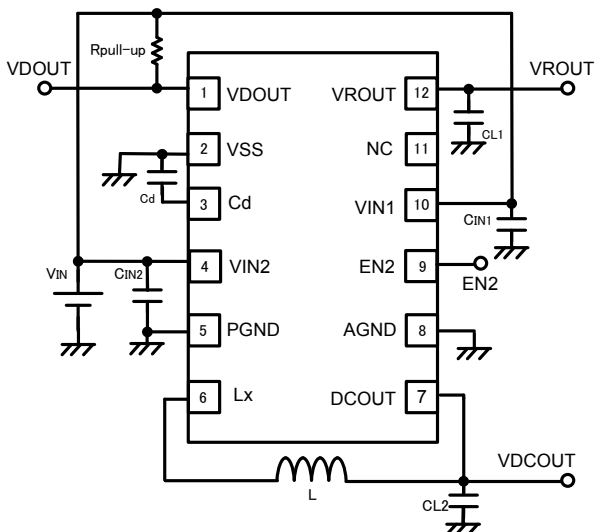

DC/DC BLOCK  $f_{OSC} = 3.0MHz$

- $C_{IN1}$  : 1  $\mu F$  (Ceramic)
- $C_{L1}$  : 1  $\mu F$  (Ceramic)
- L : 1.5  $\mu H$  (NR3015 TAIYO YUDEN)
- $C_{IN2}$  : 4.7  $\mu F$  (Ceramic)
- $C_{L2}$  : 10  $\mu F$  (Ceramic)

DC/DC BLOCK  $f_{OSC} = 1.2MHz$

- $C_{IN1}$  : 1  $\mu F$  (Ceramic)
- $C_{L1}$  : 1  $\mu F$  (Ceramic)
- L : 4.7  $\mu H$  (NR4018 TAIYO YUDEN)
- $C_{IN2}$  : 4.7  $\mu F$  (Ceramic)
- $C_{L2}$  : 10  $\mu F$  (Ceramic)

## OPERATIONAL EXPLANATION

### Voltage Regulator BLOCK

The voltage divided by resistors R1 & R2 is compared with the internal reference voltage by the error amplifier. The P-channel MOSFET which is connected to the V<sub>ROUT</sub> pin is then driven by the subsequent output signal. The output voltage at the V<sub>ROUT</sub> pin is controlled & stabilized by a system of negative feedback.

### Detector Function with the XC524 Series

The series' detector function monitors the voltage divided by resistors R3 & R4, which are connected to the V<sub>ROUT</sub> pin or the V<sub>IN1</sub> pin or the V<sub>SEN</sub> pin, as well as monitoring the voltage of the internal reference voltage source via the comparator. The V<sub>DSEN</sub> pin has options. A 'High' or 'Low' signal level can be output from the V<sub>DOUT</sub> pin when the V<sub>D</sub> pin voltage level goes below the detect voltage. The V<sub>D</sub> output logic has options. As V<sub>DOUT</sub> is an open-drain N-channel output, a pull-up resistor of about 220k is needed to achieve a voltage output.

Because of hysteresis at the detector function, output at the V<sub>DOUT</sub> pin will invert when the detect voltage level increases above the release voltage (105% of the detect voltage).

By connecting the C<sub>d</sub> pin to a capacitor, the XCM524 series can apply a delay time to V<sub>DOUT</sub> voltage when releasing voltage. The delay time can be calculated from the internal resistance, R<sub>delay</sub> (500k fixed) and the value of C<sub>d</sub> as per the following equation.

$$\text{Delay Time} = C_d \times R_{\text{delay}} \times 0.7 \dots(1)$$

Delay Time	R <sub>delay</sub> standard : 300 ~ 700k	TYP : 500k
C <sub>d</sub>	DELAY TIME (TYP.)	DELAY TIME (MIN. ~ MAX.)
0.01 μF	3.5 ms	2.1 ~ 4.9 ms
0.022 μF	7.7 ms	4.62 ~ 10.8 ms
0.047 μF	16.5 ms	9.87 ~ 23.0 ms
0.1 μF	35 ms	21.0 ~ 49.0 ms
0.22 μF	77 ms	46.2 ~ 108.0 ms
0.47 μF	165 ms	98.7 ~ 230.0 ms
1 μF	350 ms	210.0 ~ 490.0 ms

\* The release delay time values above are calculated by using the formula (1).

\*1: The release delay time is influenced by the delay capacitance C<sub>d</sub>.

### <Low ESR Capacitor>

With the XCM524 series, a stable output voltage is achievable even if used with low ESR capacitors, as a phase compensation circuit is built-in. The output capacitor (C<sub>L1</sub>) should be connected as close to V<sub>ROUT</sub> pin and V<sub>SS</sub> pin to obtain stable phase compensation. Also, please connect an input capacitor (C<sub>IN1</sub>) of 1.0 μF between the V<sub>IN1</sub> pin and the V<sub>SS</sub> pin.

Output Capacitor Chart

V <sub>ROUT</sub>	0.9 ~ 1.2V	1.3 ~ 1.7V	1.8 ~ 5.1V
C <sub>L1</sub>	≥ 4.7 μF	≥ 2.2 μF	≥ 1.0 μF

### <Current Limit, Short-Circuit Protection>

The XCM524 series' fold-back circuit operates as an output current limiter and a short protection of the output pin. When the load current reaches the current limit level, the fixed current limiter circuit operates and output voltage drops. When the output pin is shorted to the V<sub>SS</sub> level, current flows about 50mA.

## OPERATIONAL EXPLANATION (Continued)

### DC/DC BLOCK

The DC/DC block of the XCM524 series consists of a reference voltage source, ramp wave circuit, error amplifier, PWM comparator, phase compensation circuit, output voltage adjustment resistors, P-channel MOSFET driver transistor, N-channel MOSFET switch transistor for the synchronous switch, current limiter circuit, UVLO circuit and others. (See the block diagram above.)

The series ICs compare, using the error amplifier, the voltage of the internal voltage reference source with the feedback voltage from the DCOUT pin through split resistors, R1 and R2. Phase compensation is performed on the resulting error amplifier output, to input a signal to the PWM comparator to determine the turn-on time during PWM operation. The PWM comparator compares, in terms of voltage level, the signal from the error amplifier with the ramp wave from the ramp wave circuit, and delivers the resulting output to the buffer driver circuit to cause the Lx pin to output a switching duty cycle. This process is continuously performed to ensure stable output voltage.

The current feedback circuit monitors the P-channel MOS driver transistor current for each switching operation, and modulates the error amplifier output signal to provide multiple feedback signals. This enables a stable feedback loop even when a low ESR capacitor such as a ceramic capacitor is used ensuring stable output voltage.

#### <Reference Voltage Source>

The reference voltage source provides the reference voltage to ensure stable output voltage of the DC/DC converter.

#### <Ramp Wave Circuit>

The ramp wave circuit determines switching frequency. The frequency is fixed internally and can be selected from 1.2MHz or 3.0MHz. Clock pulses generated in this circuit are used to produce ramp waveforms needed for PWM operation, and to synchronize all the internal circuits.

#### <Error Amplifier>

The error amplifier is designed to monitor output voltage. The amplifier compares the reference voltage with the feedback voltage divided by the internal split resistors, R1 and R2. When a voltage is lower than the reference voltage is fed back, the output voltage of the error amplifier increases. The gain and frequency characteristics of the error amplifier output are fixed internally to deliver an optimized signal to the mixer.

#### <Current Limit>

The current limiter circuit of the XCM524series monitors the current flowing through the P-channel MOS driver transistor connected to the Lx pin, and features a combination of the current limit mode and the operation suspension mode.

When the driver current is greater than a specific level, the current limit function operates to turn off the pulses from the Lx pin at any given timing.

When the driver transistor is turned off, the limiter circuit is then released from the current limit detection state.

At the next pulse, the driver transistor is turned on. However, the transistor is immediately turned off in the case of an over current state.

When the over current state is eliminated, the IC resumes its normal operation.

The IC waits for the over current state to end by repeating the steps through . If an over current state continues for a few ms and the above three steps are repeatedly performed, the IC performs the function of latching the OFF state of the P-channel driver transistor, and goes into operation suspension mode. Once the IC is in suspension mode, operations can be resumed by either turning the IC off via the CE/MODE pin, or by restoring power to the  $V_{IN2}$  pin. The suspension mode does not mean a complete shutdown, but a state in which pulse output is suspended; therefore, the internal circuitry remains in operation. The current limit of the XCM524 series can be set at 1050mA at typical. Besides, care must be taken when laying out the PC Board, in order to prevent miss-operation of the current limit mode. Depending on the state of the PC Board, latch time may become longer and latch operation may not work. In order to avoid the effect of noise, the board should be laid out so that input capacitors are placed as close to the IC as possible.

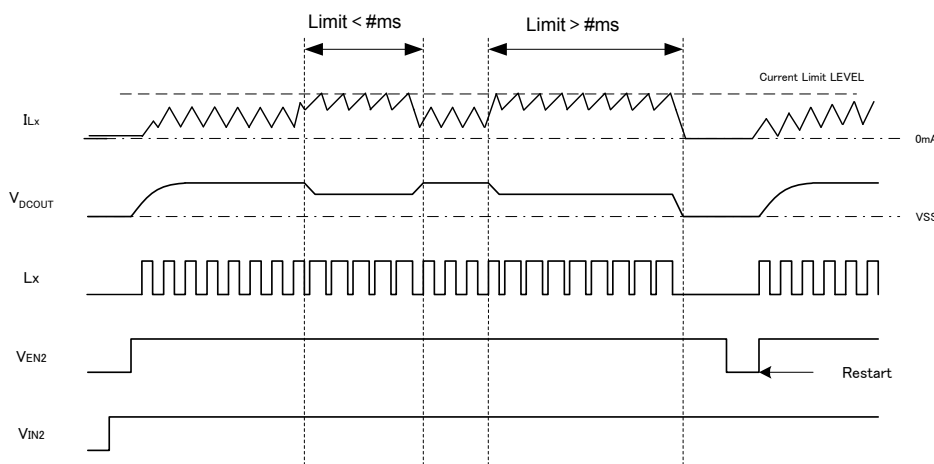

## OPERATIONAL EXPLANATION (Continued)

### <Short-Circuit Protection>

The short-circuit protection circuit monitors the internal R1 and R2 divider voltage from the DCOUT pin. In case where output is accidentally shorted to the Ground and when the FB point voltage decreases less than half of the reference voltage (Vref) and a current more than the  $I_{LIM}$  flows to the driver transistor, the short-circuit protection quickly operates to turn off and to latch the P-channel MOS driver transistor. In latch state, the operation can be resumed by either turning the IC off and on via the EN2 pin, or by restoring power supply to the  $V_{IN2}$  pin.

When sharp load transient happens, a voltage drop at the DCOUT pin is propagated to FB point through  $C_{FB}$ , as a result, short circuit protection may operate in the voltage higher than  $1/2 V_{OUT}$  voltage.

### <UVLO Circuit>

When the  $V_{IN2}$  pin voltage becomes 1.4V or lower, the P-channel output driver transistor is forced OFF to prevent false pulse output caused by unstable operation of the internal circuitry. When the  $V_{IN2}$  pin voltage becomes 1.8V or higher, switching operation takes place. By releasing the UVLO function, the IC performs the soft start function to initiate output startup operation. The soft start function operates even when the  $V_{IN}$  pin voltage falls momentarily below the UVLO operating voltage. The UVLO circuit does not cause a complete shutdown of the IC, but causes pulse output to be suspended; therefore, the internal circuitry remains in operation.

### <PFM Switch Current>

In the PFM control operation, until coil current reaches to a specified level ( $I_{PFM}$ ), the IC keeps the P-ch MOSFET on. In this case, on-time ( $t_{ON}$ ) that the P-ch MOSFET is kept on can be given by the following formula.

$$t_{ON} = L \times I_{PFM} / (V_{IN2} - V_{DCOUT}) \quad I_{PFM}$$

### <PFM duty Limit>

In the PFM control operation, the PFM duty limit (DTY<sub>LIMIT\_PFM</sub>) is set to 200% (TYP.). Therefore, under the condition that the duty increases (e.g. the condition that the step-down ratio is small), it's possible for P-ch MOSFET to be turned off even when coil current doesn't reach to  $I_{PFM}$ .

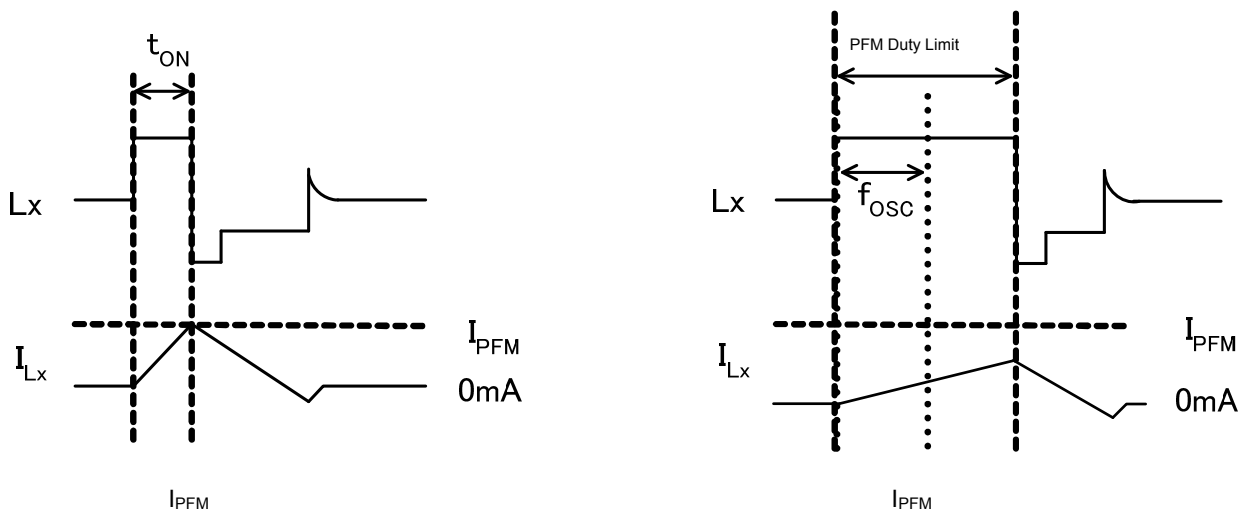

## OPERATIONAL EXPLANATION (Continued)

### <C<sub>L</sub> High Speed Discharge>

XCM524 series can quickly discharge the electric charge at the output capacitor (C<sub>L2</sub>) when a low signal to the CE pin which enables a whole IC circuit put into OFF state, is inputted via the N-channel MOS switch located between the L<sub>X</sub> pin and the V<sub>SS</sub> pin. When the IC is disabled, electric charge at the output capacitor (C<sub>L</sub>) is quickly discharged so that it may avoid application malfunction. Discharge time of the output capacitor (C<sub>L</sub>) is set by the C<sub>L</sub> auto-discharge resistance (R) and the output capacitor (C<sub>L</sub>). By setting time constant of a C<sub>L</sub> auto-discharge resistance value [R] and an output capacitor value (C<sub>L2</sub>) as ( =C x R), discharge time of the output voltage after discharge via the N channel transistor is calculated by the following formula.

$$V = V_{DCOUT(T)} \times e^{-t/\tau} \text{ or } t = -\tau \ln(V_{DCOUT(T)}/V)$$

V : Output voltage after discharge,

V<sub>DCOUT(T)</sub> : Output voltage after discharge

t: Discharge time

τ : C×R

C = Capacitance of Output capacitor ( C<sub>L2</sub> )

R = C<sub>L</sub> auto-discharge resistance

Output Voltage Discharge Characteristics  
R<sub>dischg</sub> = 300 Ω (TYP)

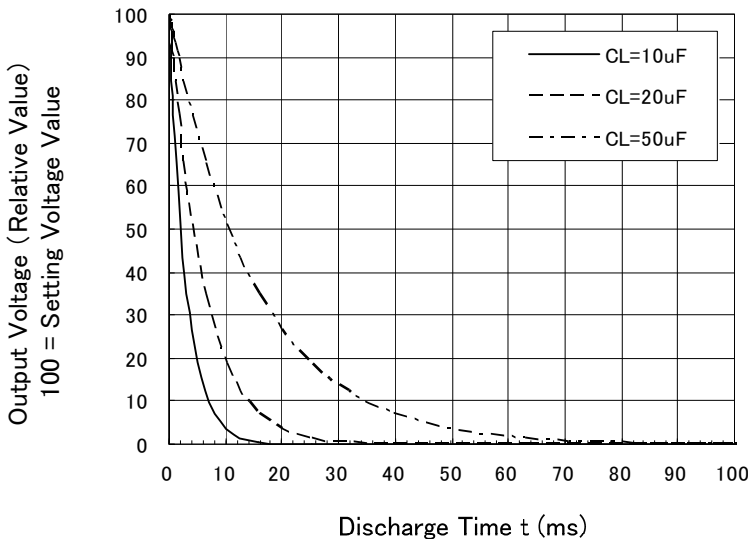

## NOTE ON USE

When the DC/DC converter and the VR are connected as V<sub>DCOUT</sub>=V<sub>IN1</sub>, the following points should be noted.

1. When larger value is used in DC/DC output capacitor C<sub>L2</sub>, the larger value is also used in C<sub>L1</sub> as in proportional. Please be noted that when C<sub>L2</sub> capacitance of the VR is getting large, an inrush current increases at VR start-up, DC/DC short circuit protection starts to operate, as a result, the IC may happen to stop.

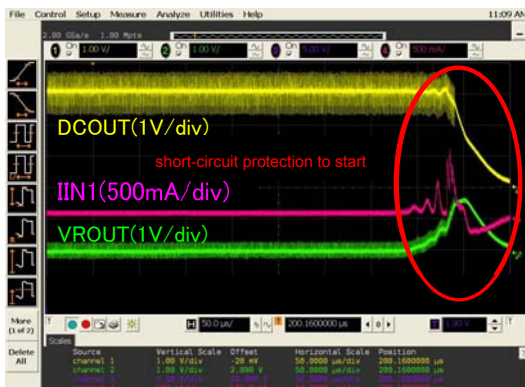

50us/div

\* VR inrush current I<sub>IN1</sub> makes DC/DC short-circuit protection to start, as a result, the IC may happen to stop.

The left waver forms are taken at C<sub>L1</sub>=10 μ, C<sub>L2</sub>=10 μ F (in contrast to the recommended 1.0 μ F).

## NOTE ON USE (Continued)

### <VDR BLOCK>

1. Please use this IC within the stated absolute maximum ratings. The IC is liable to malfunction should the ratings be exceeded.
2. Where wiring impedance is high, operations may become unstable due to noise and/or phase lag depending on output current. Especially,  $V_{IN1}$  and  $V_{SS}$  wiring should be taken into consideration for reinforcement.
3. Please wire the input capacitor ( $C_{IN1}$ ) and the output capacitor ( $C_{L1}$ ) as close to the IC as possible. Care shall be taken for capacitor selection to ensure stability of phase compensation from the point of ESR influence.

### <DC/DC BLOCK>

1. The XCM524 series is designed for use with ceramic output capacitors. If, however, the potential difference is too large between the input voltage and the output voltage, a ceramic capacitor may fail to absorb the resulting high switching energy and oscillation could occur on the output. If the input-output potential difference is large, connect an electrolytic capacitor in parallel to compensate for insufficient capacitance.
2. Spike noise and ripple voltage arise in a switching regulator as with a DC/DC converter. These are greatly influenced by external component selection, such as the coil inductance, capacitance values, and board layout of external components. Once the design has been completed, verification with actual components should be done.
3. As a result of input-output voltage and load conditions, oscillation frequency goes to 1/2, 1/3, and continues, then a ripple may increase.
4. When input-output voltage differential is large and light load conditions, a small duty cycle comes out. After that, 0% duty cycle may continue in several periods.
5. When input-output voltage differential is small and heavy load conditions, a large duty cycle comes out and may continue 100% duty cycle in several periods.
6. With the IC, the peak current of the coil is controlled by the current limit circuit. Since the peak current increases when dropout voltage or load current is high, current limit starts operation, and this can lead to instability. When peak current becomes high, please adjust the coil inductance value and fully check the circuit operation. In addition, please calculate the peak current according to the following formula:

$$I_{pk} = (V_{IN2} - V_{DCOUT}) \times \text{OnDuty} / (2 \times L \times f_{OSC}) + I_{OUT2}$$

L : Coil Inductance Value

$f_{OSC}$  : Oscillation Frequency

7. When the peak current which exceeds limit current flows within the specified time, the built-in P-channel MOS driver transistor turns off. During the time until it detects limit current and before the P-channel built-in transistor can be turned off, the current for limit current flows; therefore, care must be taken when selecting the rating for the external components such as a coil.
8. Depending on the state of the PC Board, latch time may become longer and latch operation may not work. In order to avoid the effect of noise, the board should be laid out so that input capacitors are placed as close to the IC as possible.
9. Use of the IC at voltages below the recommended voltage range may lead to instability.
10. This IC should be used within the stated absolute maximum ratings in order to prevent damage to the device.
11. When the IC is used in high temperature, output voltage may increase up to input voltage level at no load because of the leak current of the P-channel MOS driver transistor.



## NOTE ON USE (Continued)

12. The current limit is set to 1350mA (MAX.) at typical. However, the current of 1350mA or more may flow. In case that the current limit functions while the DCOUT pin is shorted to the GND pin, when P-channel MOSFET is ON, the potential difference for input voltage will occur at both ends of a coil. For this, the time rate of coil current becomes large. By contrast, when N-channel MOSFET switch is ON, there is almost no potential difference at both ends of the coil since the DCOUT pin is shorted to the GND pin. Consequently, the time rate of coil current becomes quite small. According to the repetition of this operation, and the delay time of the circuit, coil current will be converged on a certain current value, exceeding the amount of current, which is supposed to be limited originally. Even in this case, however, after the over current state continues for several ms, the circuit will be latched. A coil should be used within the stated absolute maximum rating in order to prevent damage to the device.

Current flows into P-channel MOS driver transistor to reach the current limit ( $I_{LIM}$ ).

The current of  $I_{LIM}$  or more flows since the delay time of the circuit occurs during from the detection of the current limit to OFF of P-channel MOS driver transistor.

Because of no potential difference at both ends of the coil, the time rate of coil current becomes quite small.

$L_x$  oscillates very narrow pulses by the current limit for several ms.

The circuit is latched, stopping its operation.

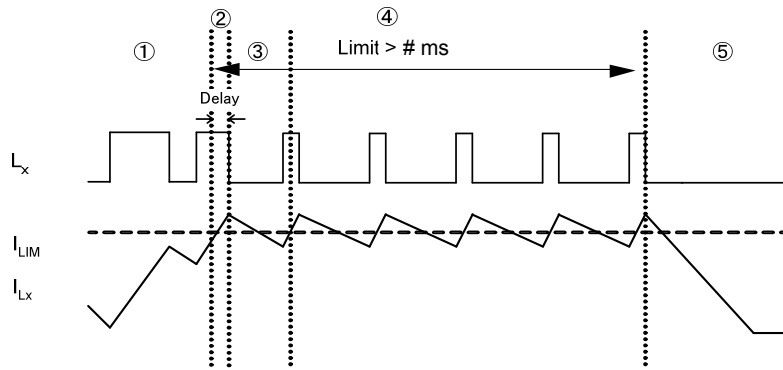

13. In order to stabilize  $V_{IN1}$ 's voltage level and oscillation frequency, we recommend that a by-pass capacitor ( $C_{IN2}$ ) be connected as close as possible to the  $V_{IN2}$  &  $V_{SS}$  pins.
14. High step-down ratio and very light load may lead an intermittent oscillation.
15. During PWM / PFM automatic switching mode, operating may become unstable at transition to continuous mode. Please verify with actual parts.

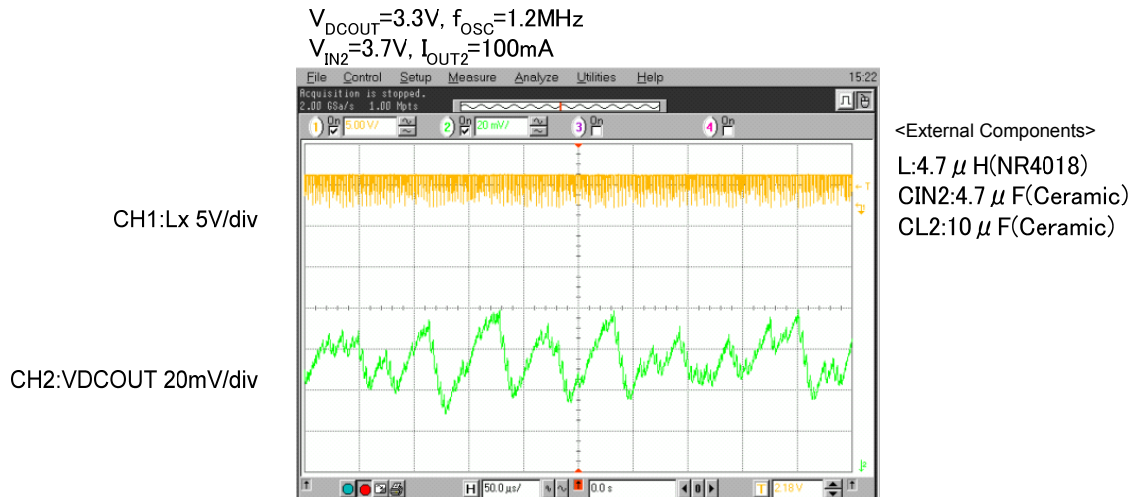

## NOTE ON USE (Continued)

16. Please note the L value of the coil. The IC may enter unstable operation if the combination of ambient temperature, setting voltage, oscillation frequency, and L value are not adequate.



The Range of L Value

$f_{OSC}$	$V_{DCOUT}$	L Value
3.0MHz	0.8V $V_{DCOUT}$ 4.0V	1.0 $\mu$ H ~ 2.2 $\mu$ H
1.2MHz	$V_{DCOUT}$ 2.5V	3.3 $\mu$ H ~ 6.8 $\mu$ H
	2.5V < $V_{DCOUT}$	4.7 $\mu$ H ~ 6.8 $\mu$ H

\*When a coil less value of 4.7  $\mu$  H is used at when a coil less value of 1.5  $\mu$  H is used at  $f_{OSC}=3.0MHz$ , peak coil current more easily reach the current limit ILMI. In this case, it may happen that the IC can not provide 600mA output current.

17. Under input-output voltage differential is large, operating may become unstable at transition to continuous mode. Please verify with actual parts.

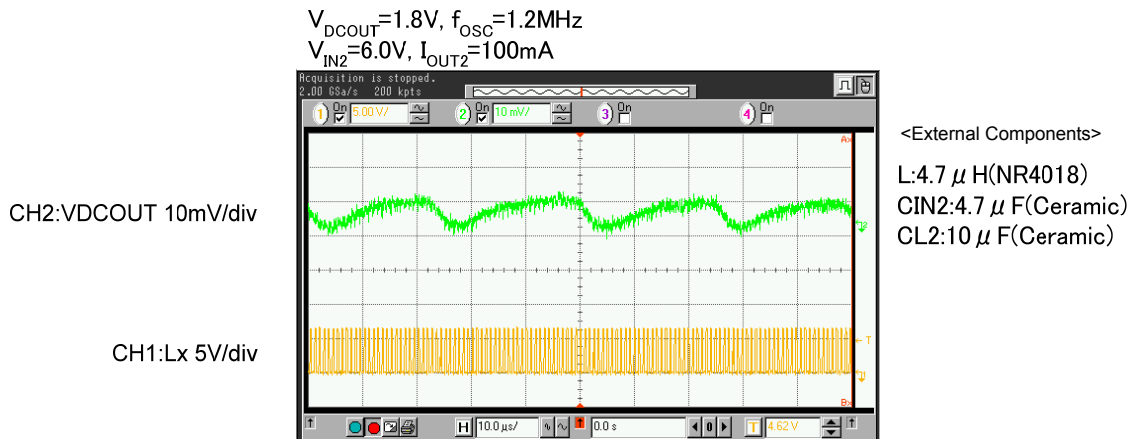

### Instructions of pattern layouts

1. Please use this IC within the stated absolute maximum ratings. The IC is liable to malfunction should the ratings be exceeded.
2. In order to stabilize  $V_{IN1}$  ·  $V_{IN2}$  ·  $DCOUT$  ·  $V_{ROUT}$  voltage level, we recommend that a by-pass capacitor ( $C_{IN1}$  ·  $C_{IN2}$  ·  $C_{L1}$  ·  $C_{L2}$ ) be connected as close as possible to the  $V_{IN1}$  ·  $V_{IN2}$  ·  $DCOUT$  ·  $V_{ROUT}$  and GND ·  $V_{SS}$  pins.
3. Please mount each external component as close to the IC as possible.
4. Wire external components as close to the IC as possible and use thick, short connecting traces to reduce the circuit impedance.
5.  $V_{SS}$  (AGND · PGND ·  $V_{SS}$ ) ground wiring is recommended to get large area. The IC may goes into unstable operation as a result of  $V_{SS}$  voltage level fluctuation during the switching.
6. This series' internal driver transistors bring on heat because of the output current ( $I_{OUT}$ ) and ON resistance of driver transistors.

### Recommended Pattern Layout

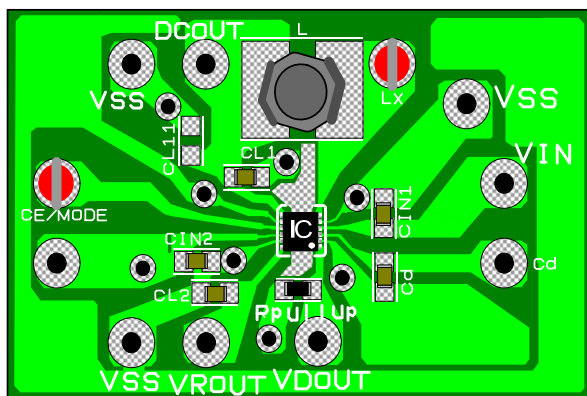

Front

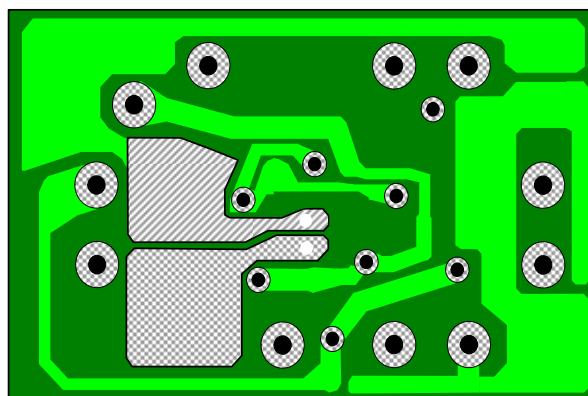

Back

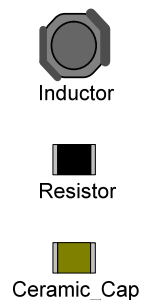

# TEST CIRCUITS

Circuit No.1

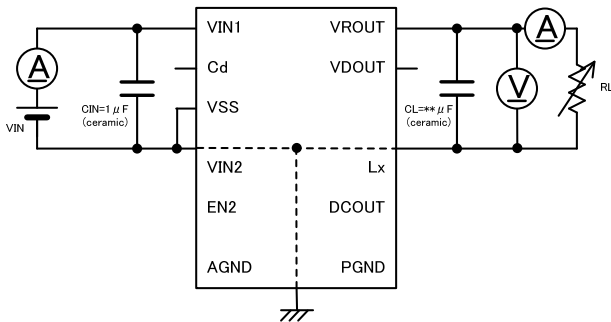

Circuit No.2

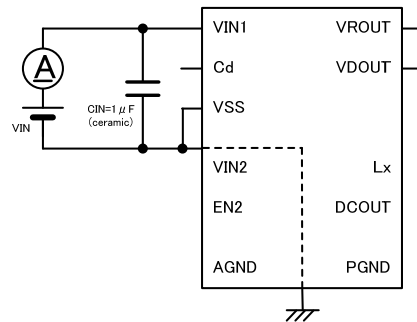

Circuit No.3

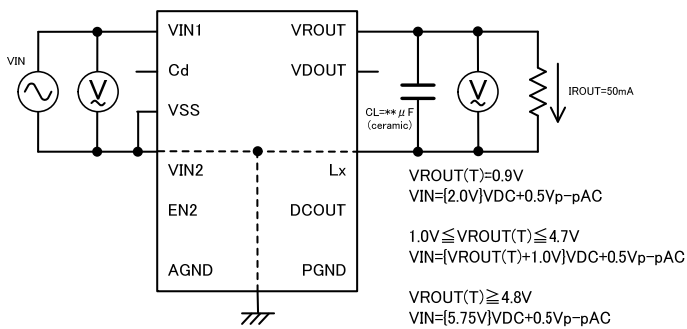

Circuit No.4

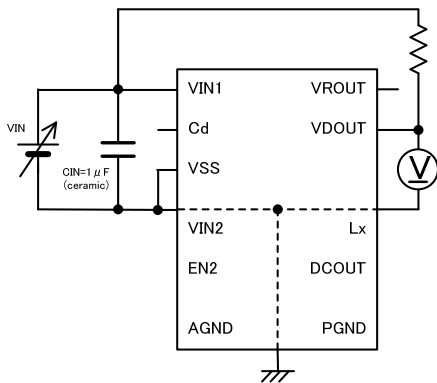

Circuit No.5

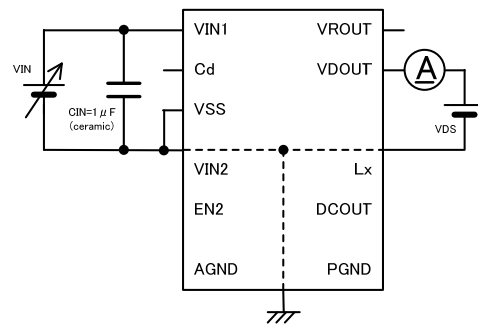

Circuit No.6

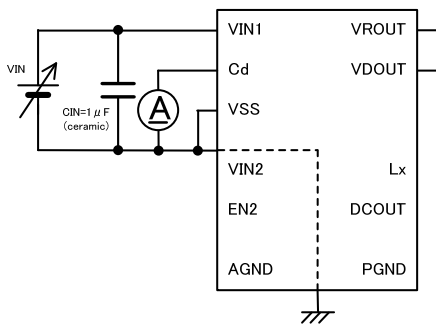

## Output Capacitor

$V_{ROUT}$	0.9 ~ 1.2V	1.3 ~ 1.7V	1.8V ~ 5.1V
$C_L$	4.7 $\mu F$	2.2 $\mu F$	1.0 $\mu F$

## TEST CIRCUITS (Continued)

Circuit No.7

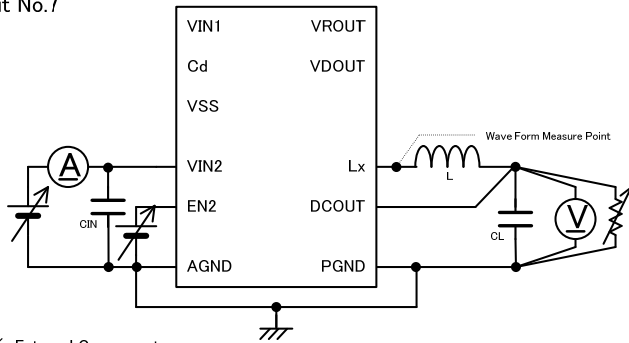

※ External Components  
 L : 1.5  $\mu$ H(NR3015) 3.0MHz, 4.7  $\mu$ H(NR4018) 1.2MHz  
 CIN : 4.7  $\mu$ F(ceramic), CL : 10  $\mu$ F(ceramic)

Circuit No.8

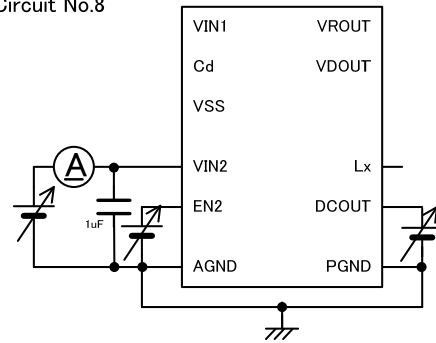

Circuit No.9

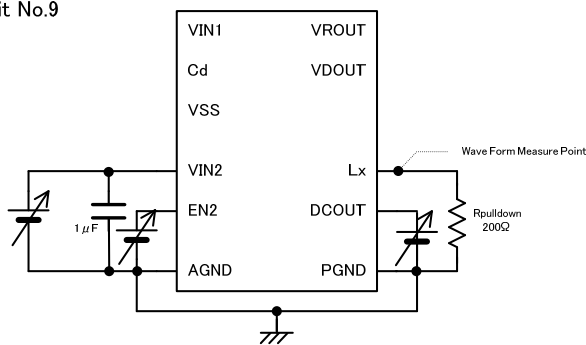

Circuit No.10

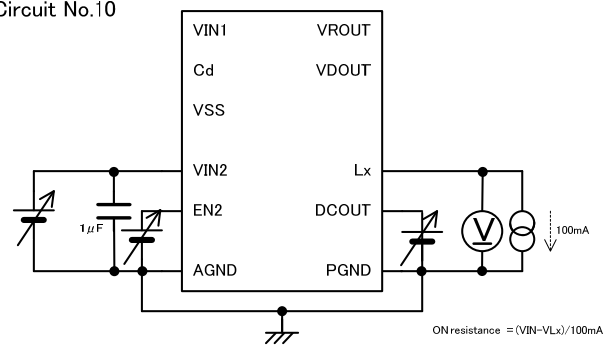

Circuit No.11

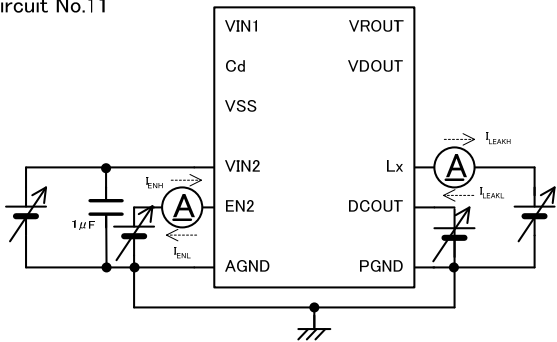

Circuit No.12

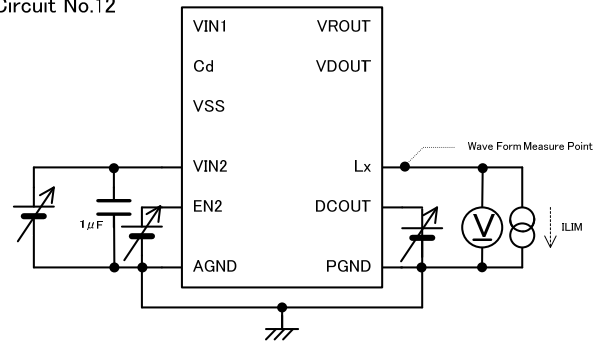

Circuit No.13

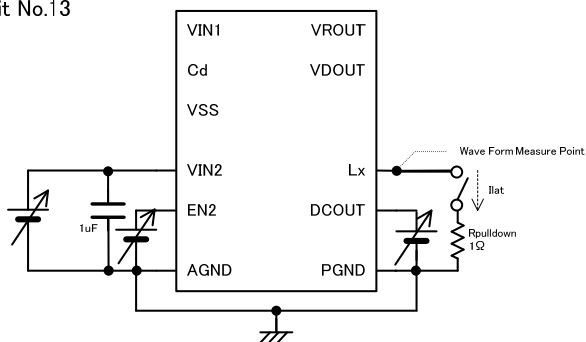

Circuit No.14

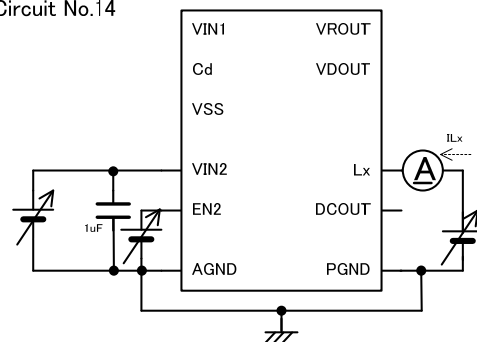

Circuit No.15

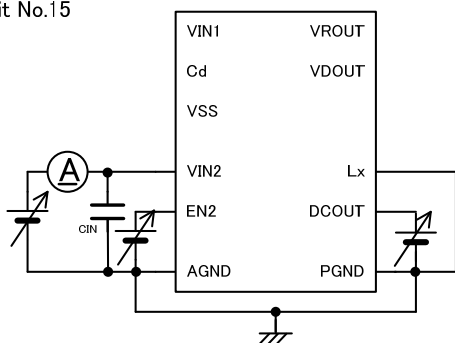

# TYPICAL PERFORMANCE CHARACTERISTICS

1ch:VDR Block

( 1 ) VR Output Voltage vs. VR Output Current

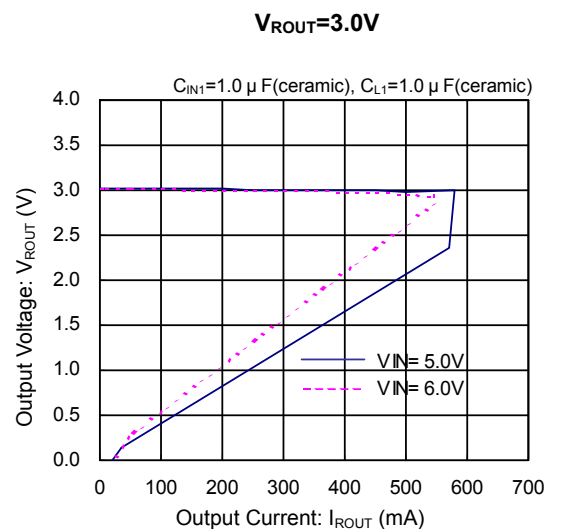
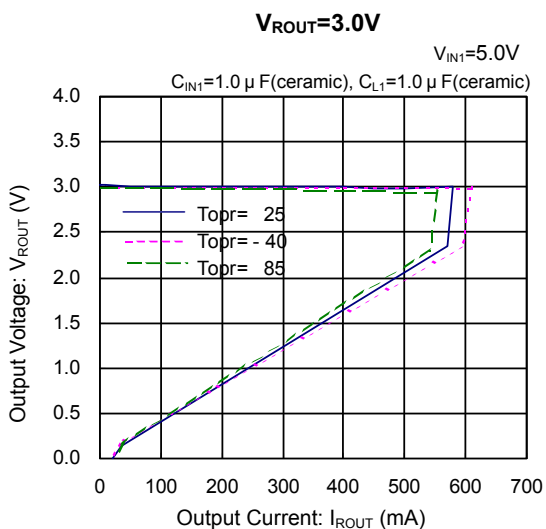
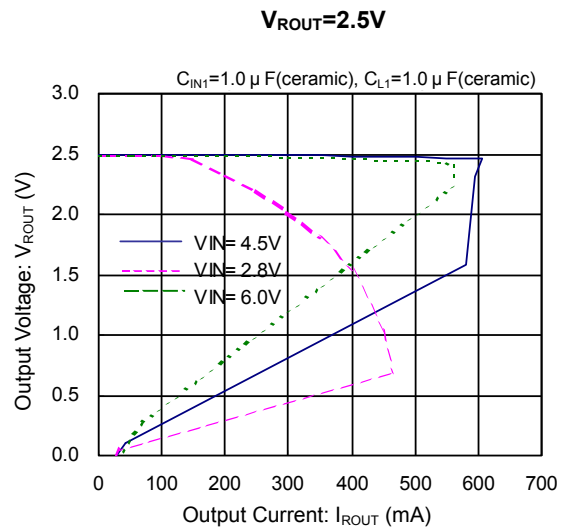
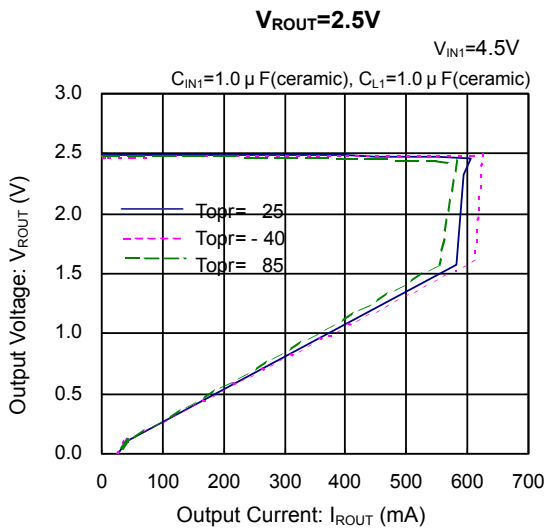
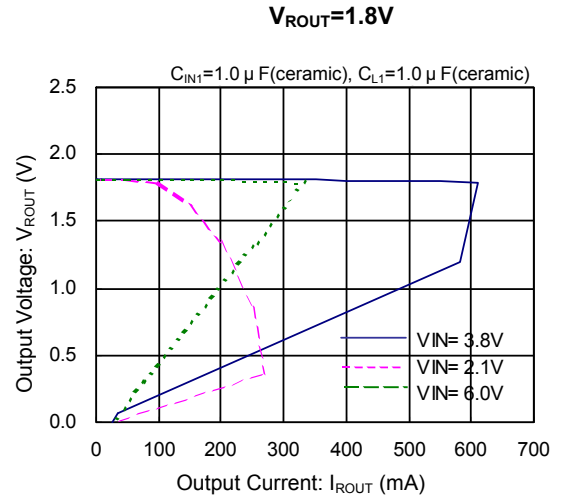
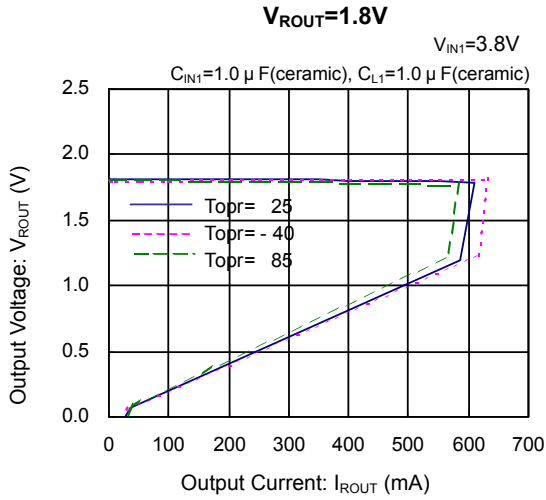

## TYPICAL PERFORMANCE CHARACTERISTICS (Continued)

( 1 ) VR Output Voltage vs. VR Output Current (Continued)

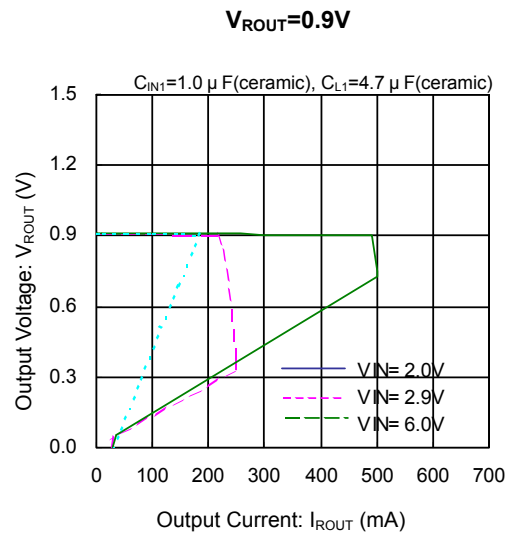
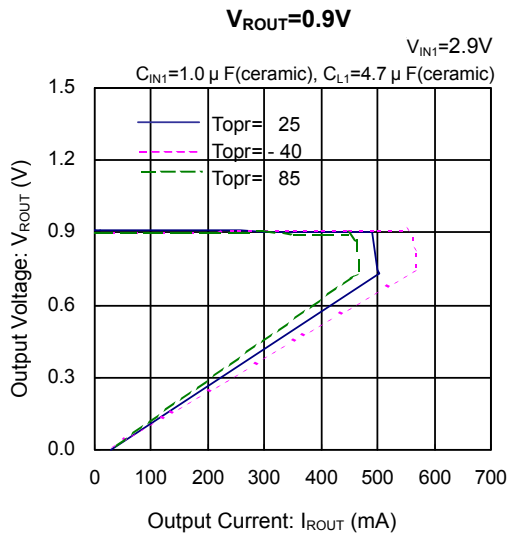
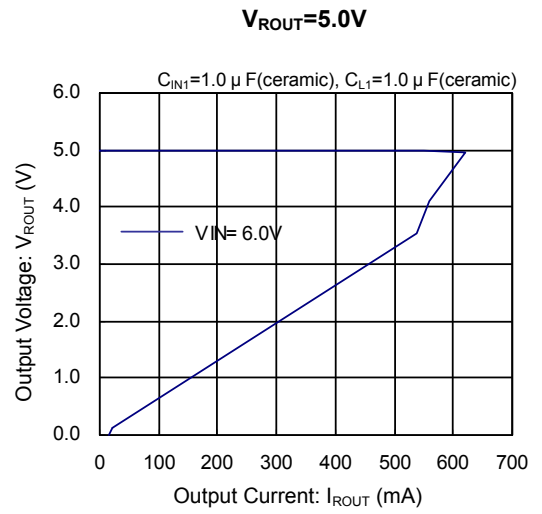
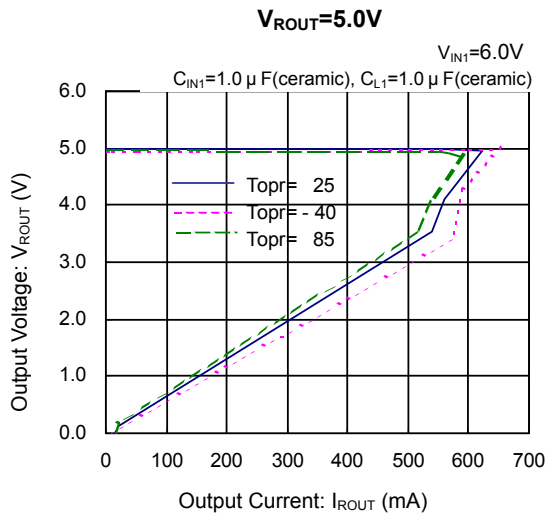

# TYPICAL PERFORMANCE CHARACTERISTICS (Continued)

## (2) VR Output Voltage vs. Input Voltage

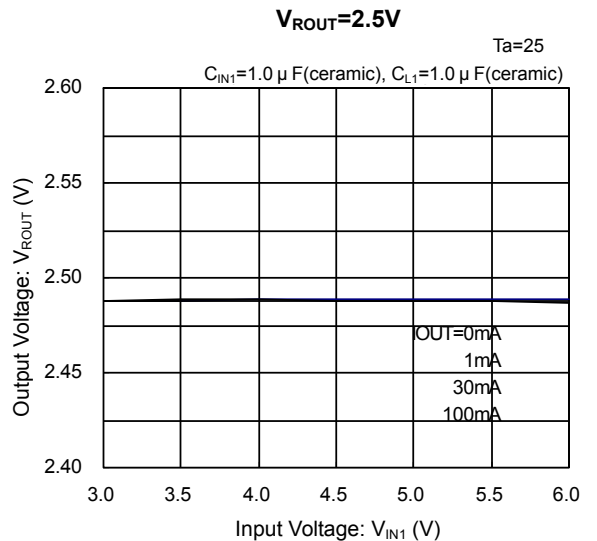
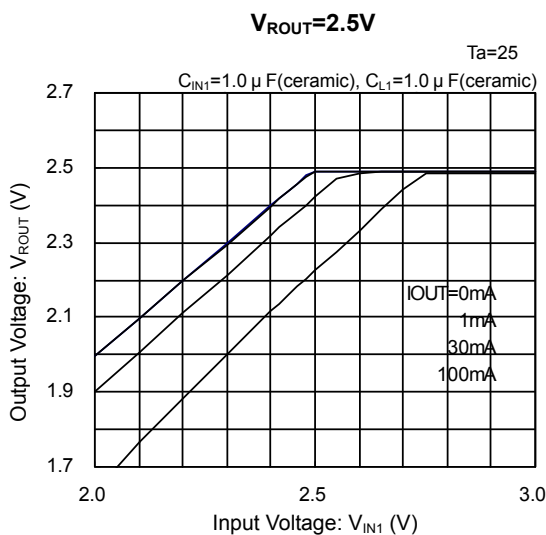
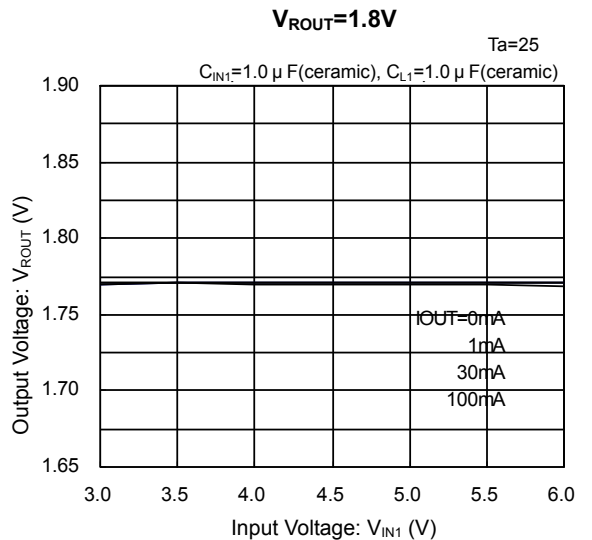
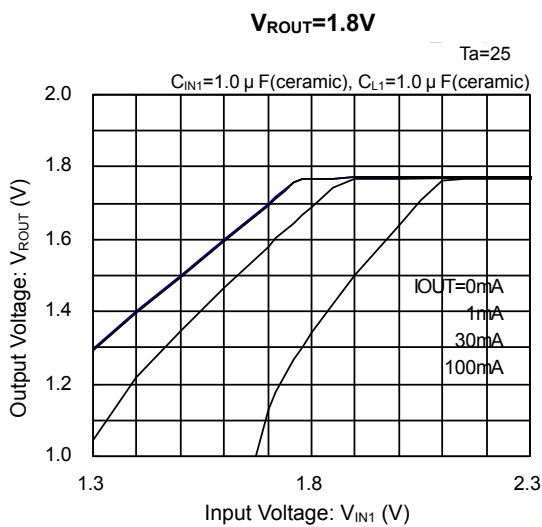
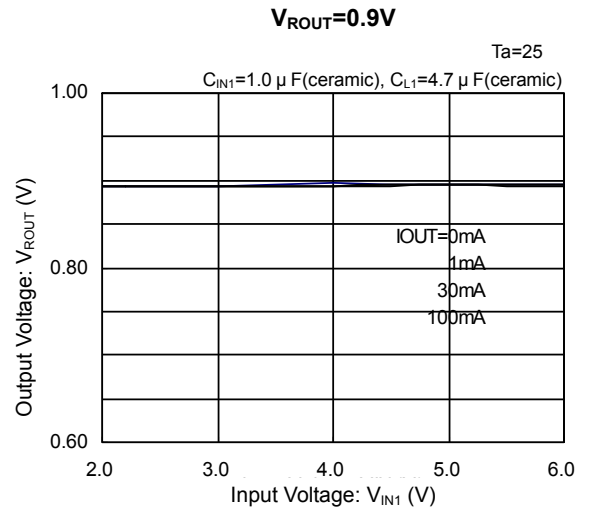
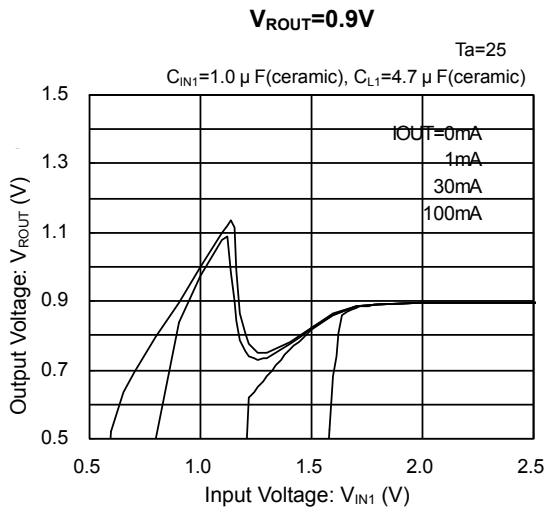

## TYPICAL PERFORMANCE CHARACTERISTICS (Continued)

( 2 ) VR Output Voltage vs. Input Voltage (Continued)

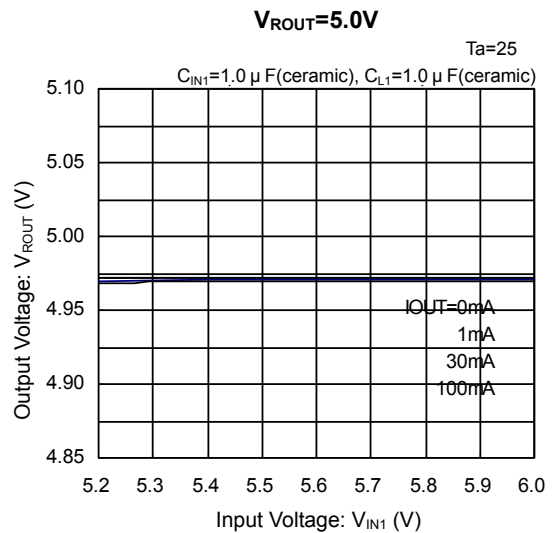
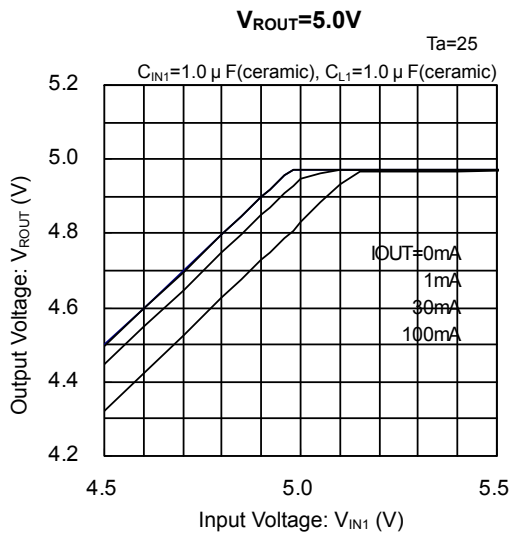
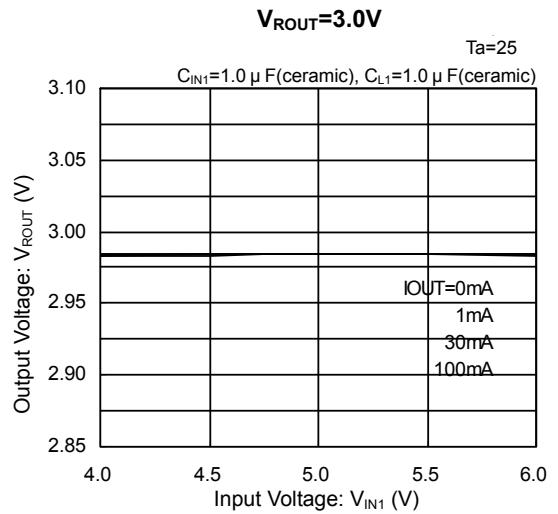
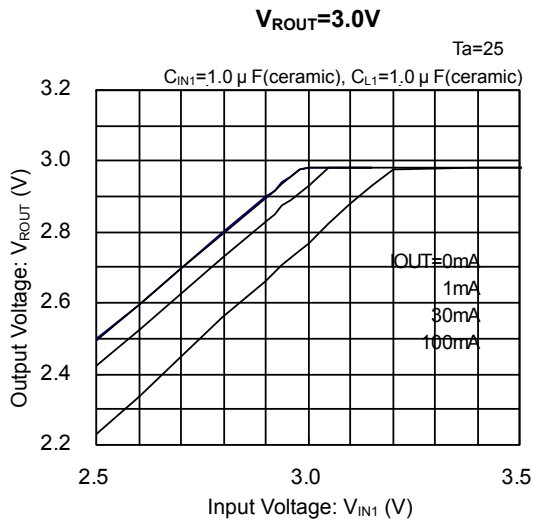



# TYPICAL PERFORMANCE CHARACTERISTICS (Continued)

## (3) Dropout Voltage vs. VR Output Current

**V<sub>ROUT</sub>=0.9V**

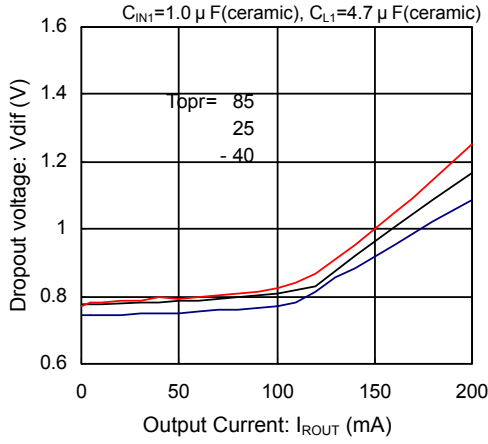

**V<sub>ROUT</sub>=1.8V**

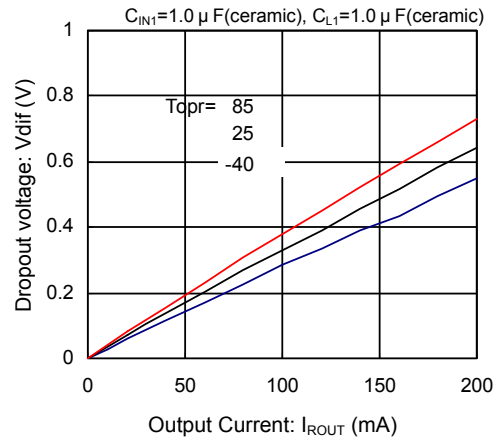

**V<sub>ROUT</sub>=2.5V**

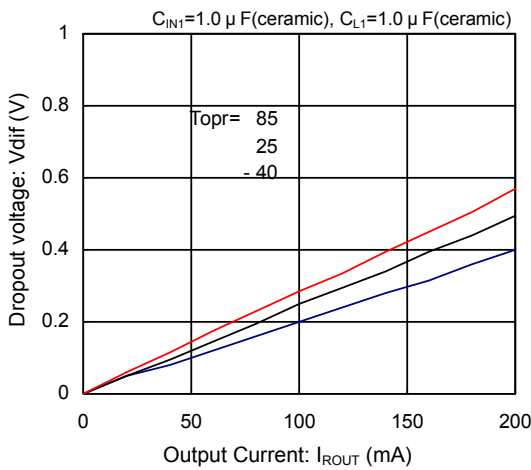

**V<sub>ROUT</sub>=3.0V**

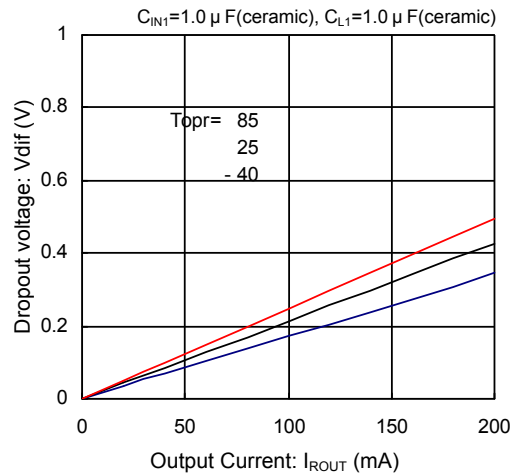

**V<sub>ROUT</sub>=5.0V**

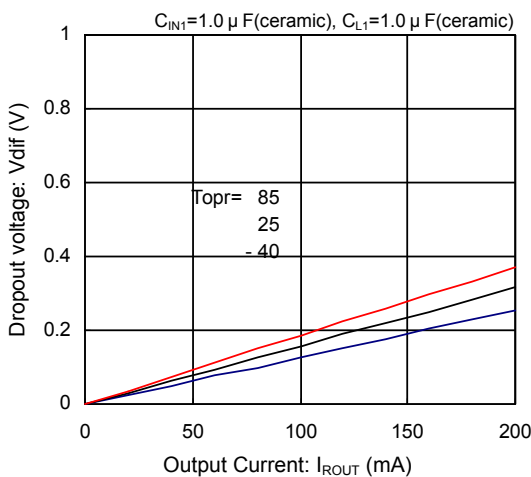

## TYPICAL PERFORMANCE CHARACTERISTICS (Continued)

### ( 4 ) Supply Current vs. Input Voltage

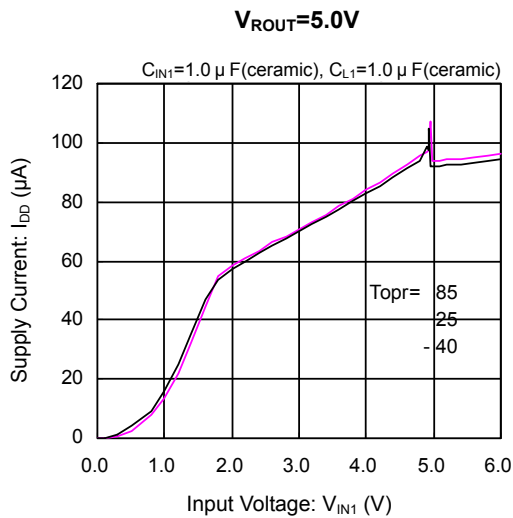
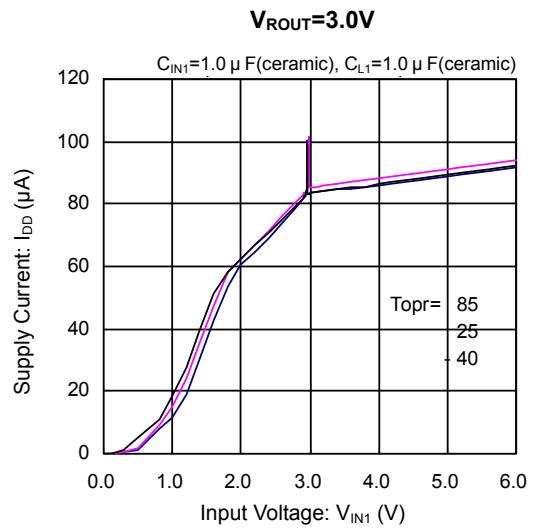
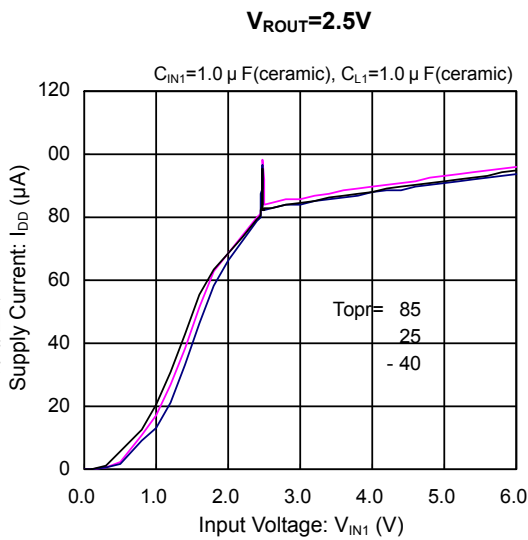
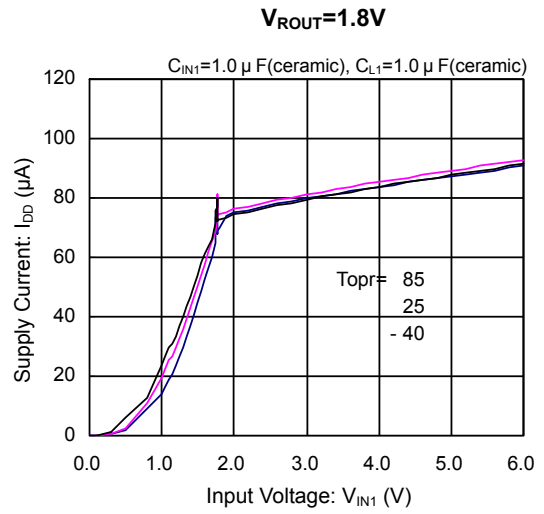
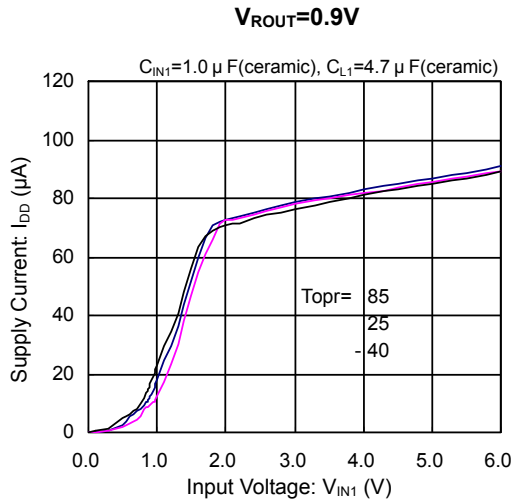

# TYPICAL PERFORMANCE CHARACTERISTICS (Continued)

## ( 5 ) VR Output Voltage vs. Ambient Temperature

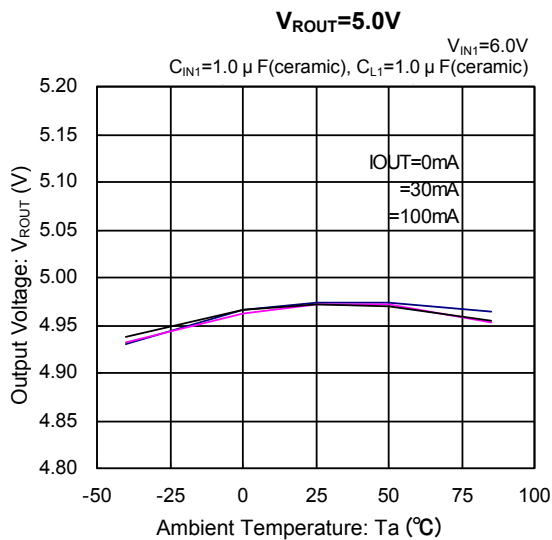
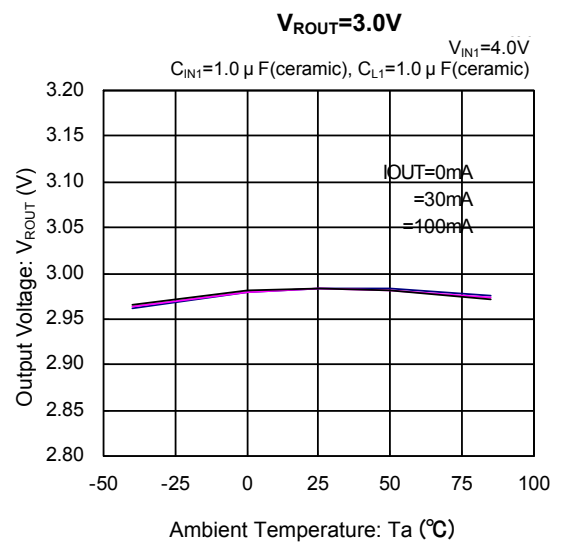
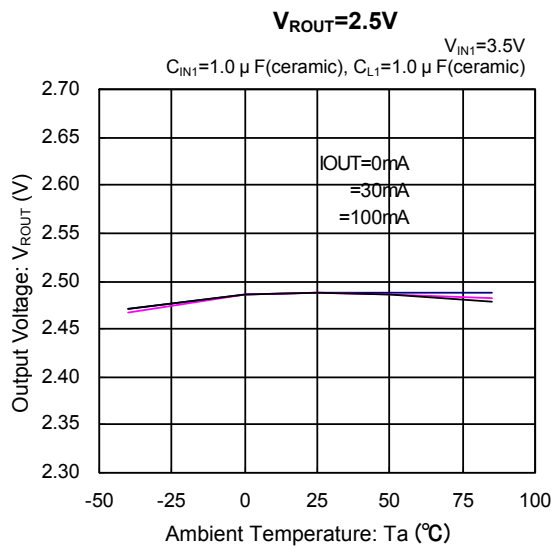
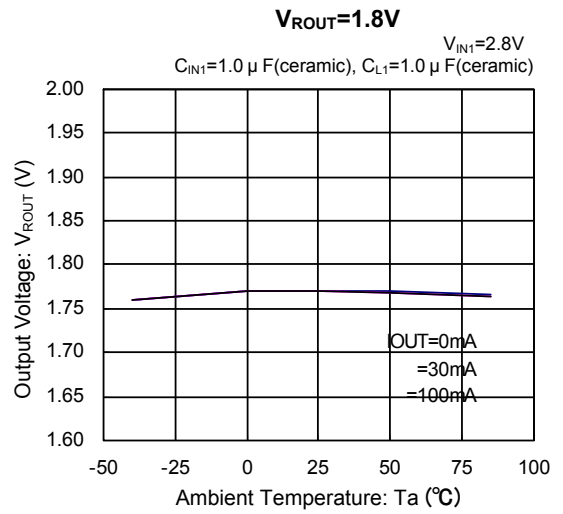
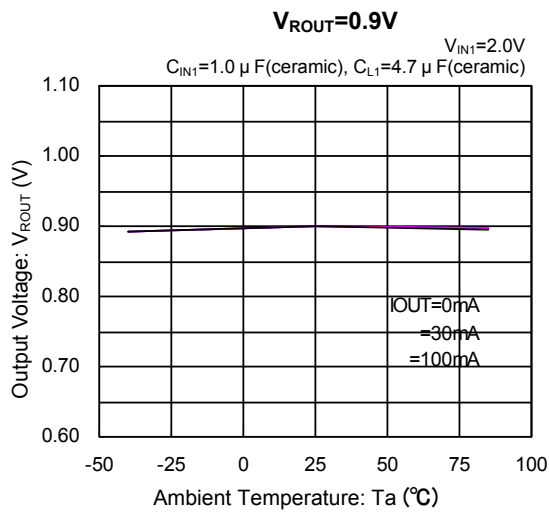

## TYPICAL PERFORMANCE CHARACTERISTICS (Continued)

### (6) Supply Current vs. Ambient Temperature

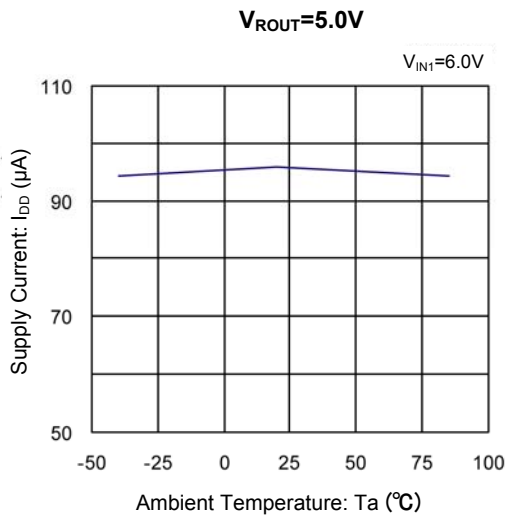
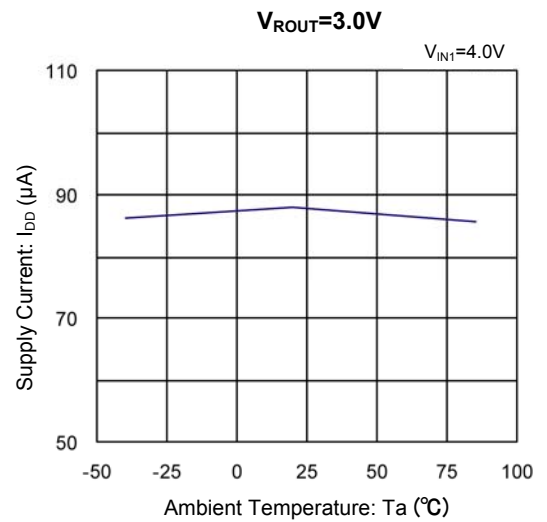
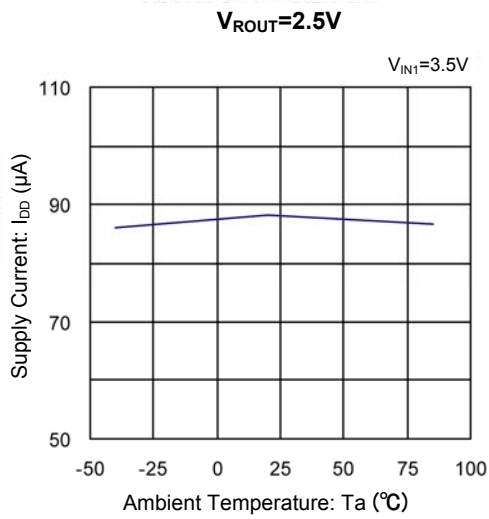
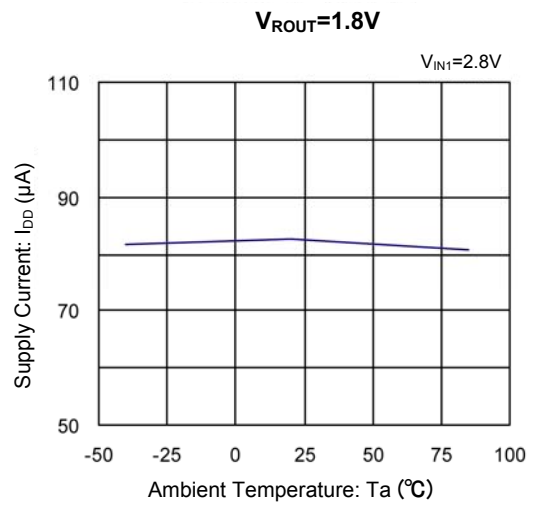
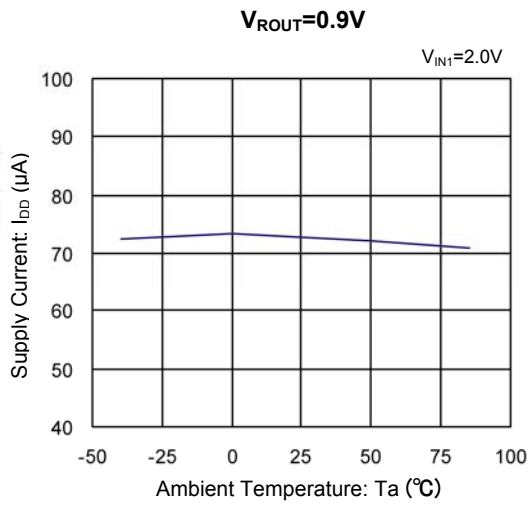

# TYPICAL PERFORMANCE CHARACTERISTICS (Continued)

( 7 ) Rdelay vs. Ambient Temperature

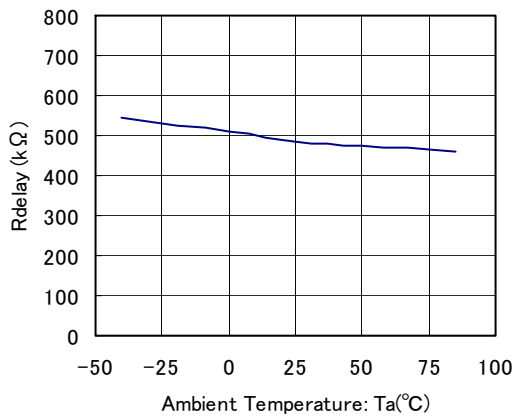

( 8 ) Output Noise Density

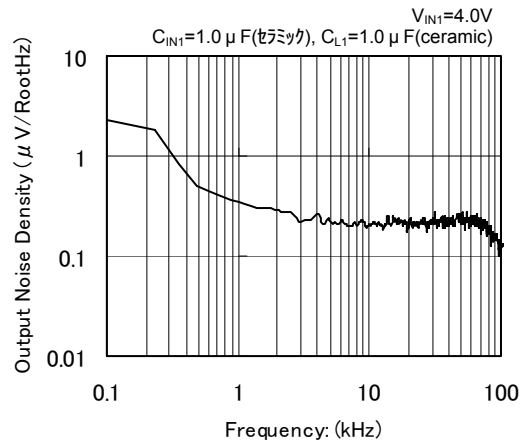

( 9 ) Detect Voltage, Release Voltage vs. Ambient Temperature

**V<sub>DF</sub>=2.0V**

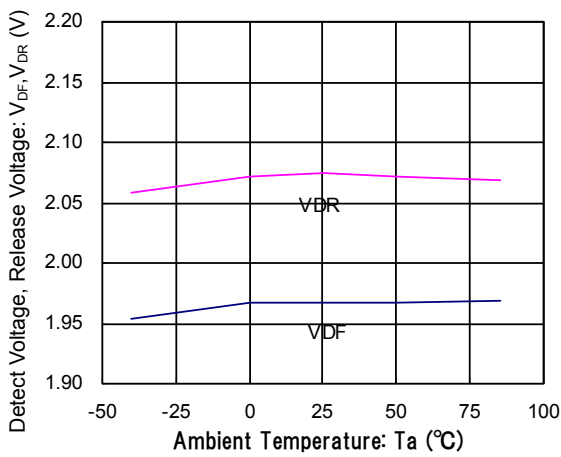

**V<sub>DF</sub>=2.7V**

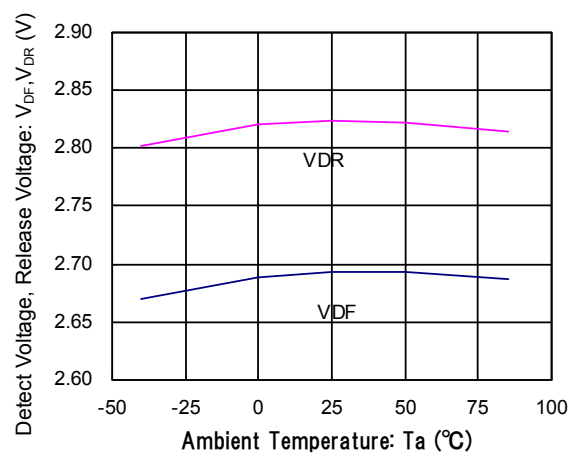

**V<sub>DF</sub>=3.6V**

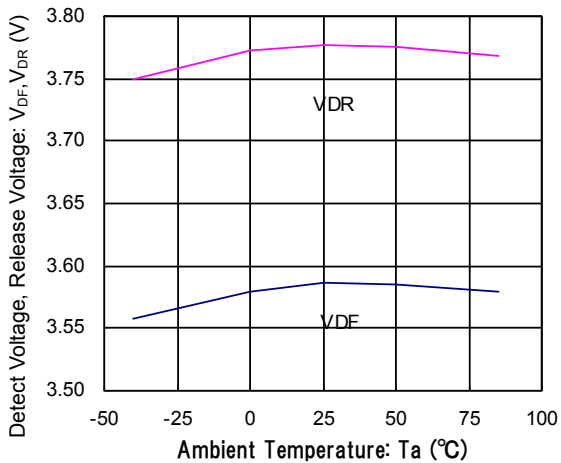

**V<sub>DF</sub>=5.0V**

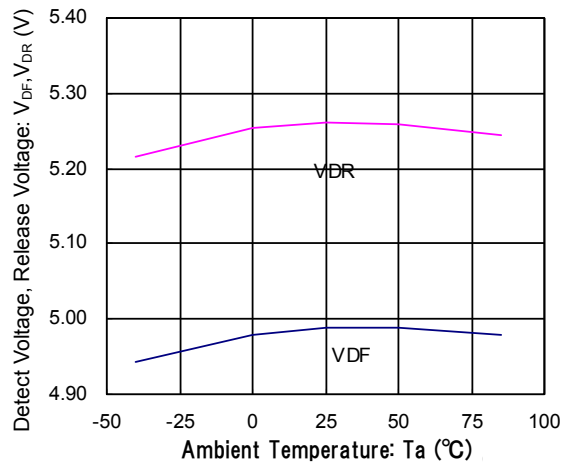

## TYPICAL PERFORMANCE CHARACTERISTICS (Continued)

( 10 ) VD N-channel Driver Transistor Output Current vs. VDS

**V<sub>DF</sub>=2.0V**

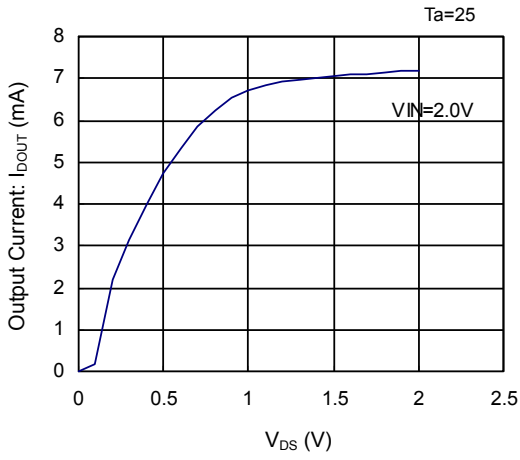

**V<sub>DF</sub>=2.7V**

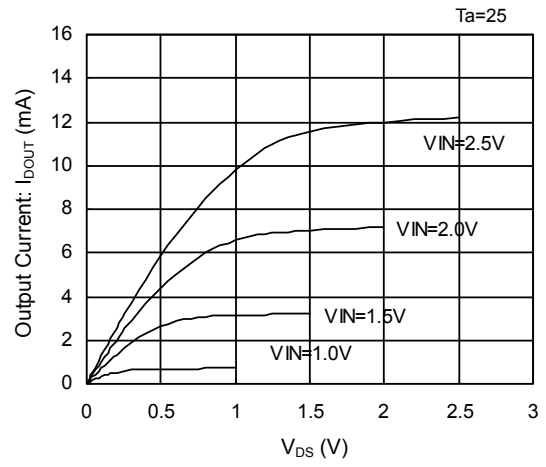

**V<sub>DF</sub>=3.6V**

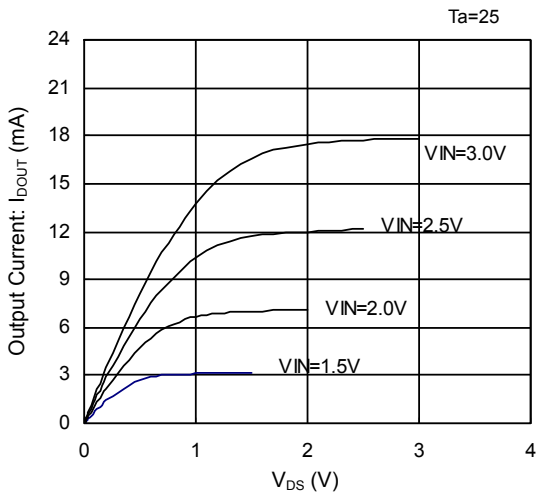

**V<sub>DF</sub>=5.0V**

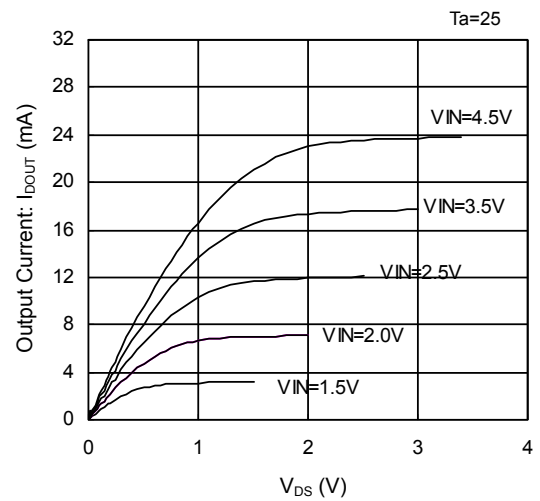

# TYPICAL PERFORMANCE CHARACTERISTICS (Continued)

( 11 ) VD N-channel Driver Transistor Output Current vs. Input Voltage

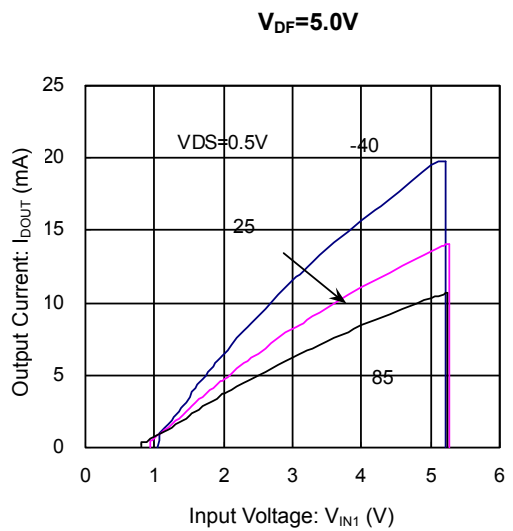
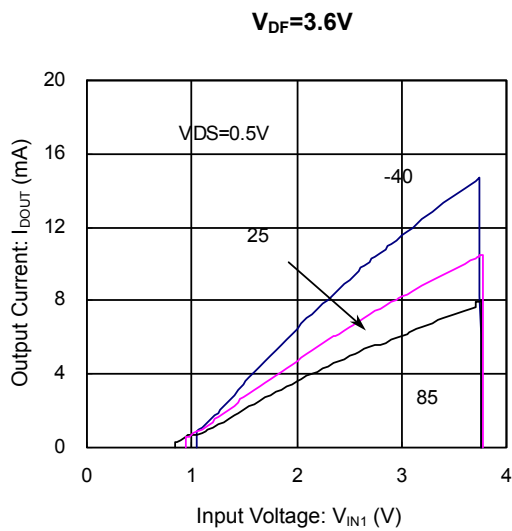
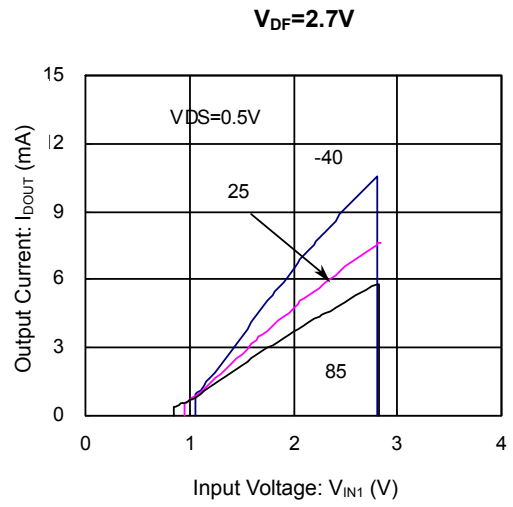
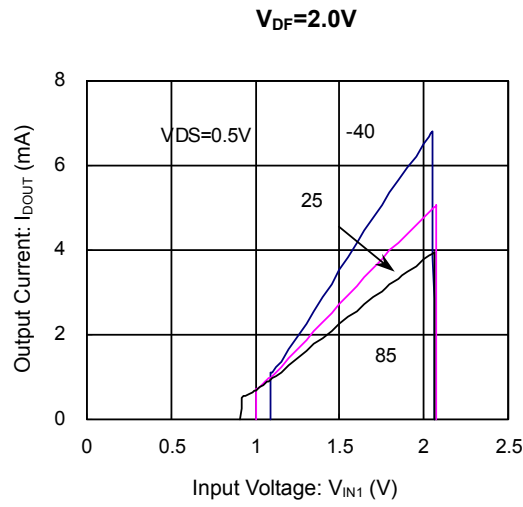

## TYPICAL PERFORMANCE CHARACTERISTICS (Continued)

### ( 12 ) Input Transient Response

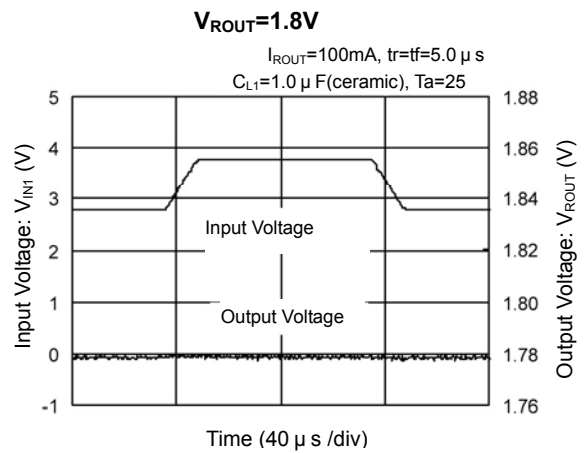
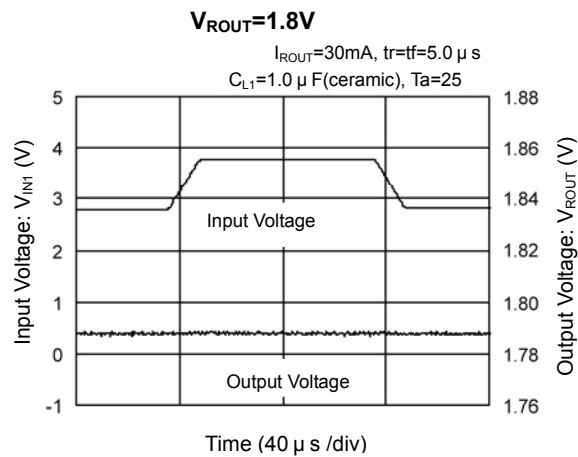
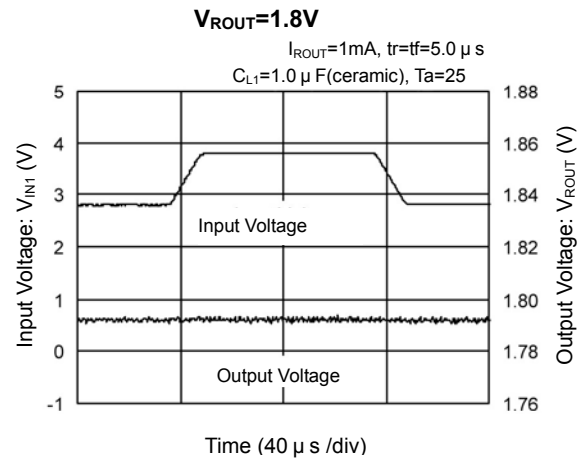
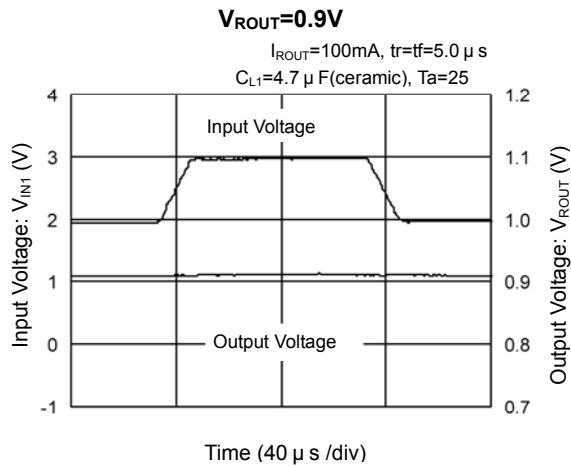
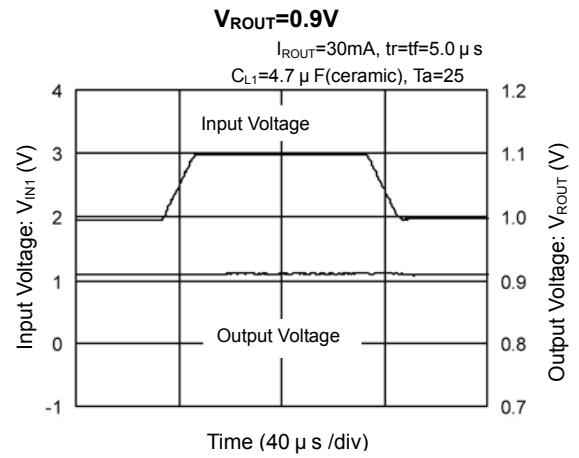
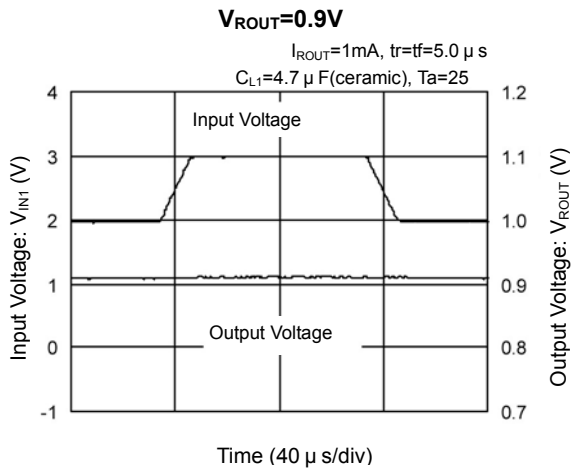



# TYPICAL PERFORMANCE CHARACTERISTICS (Continued)

## ( 12 ) Input Transient Response (Continued)

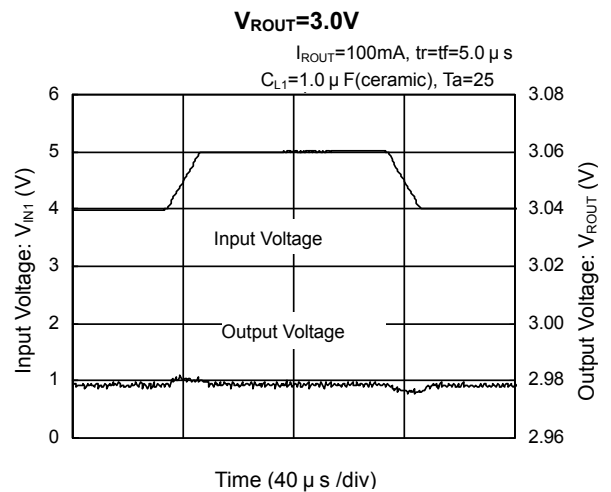
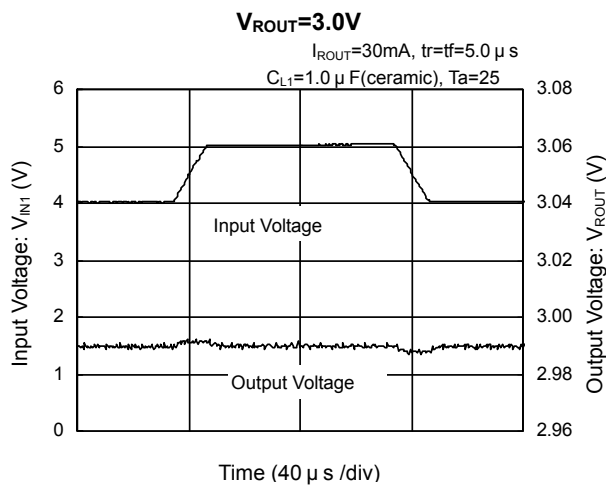
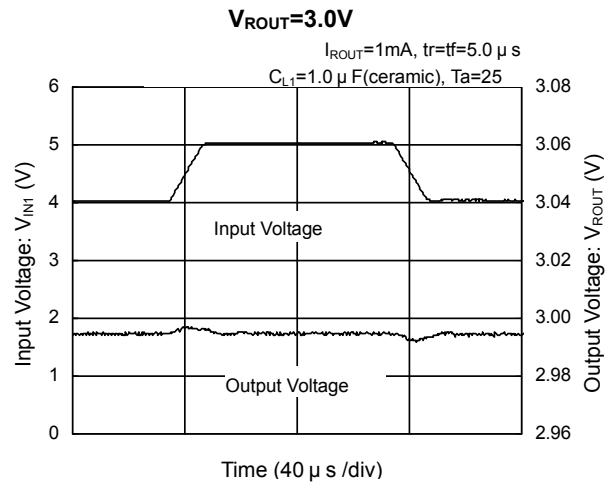
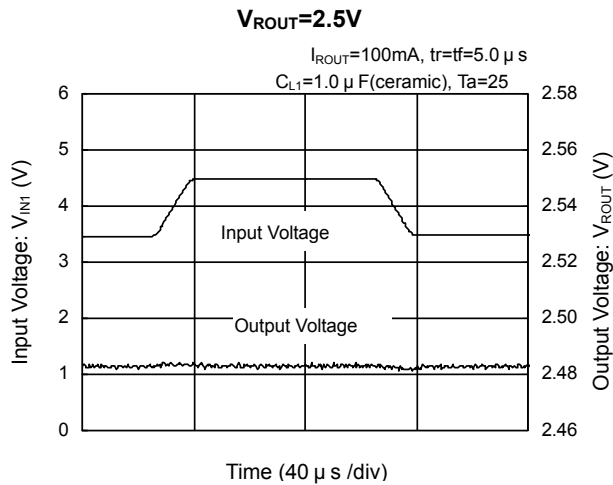
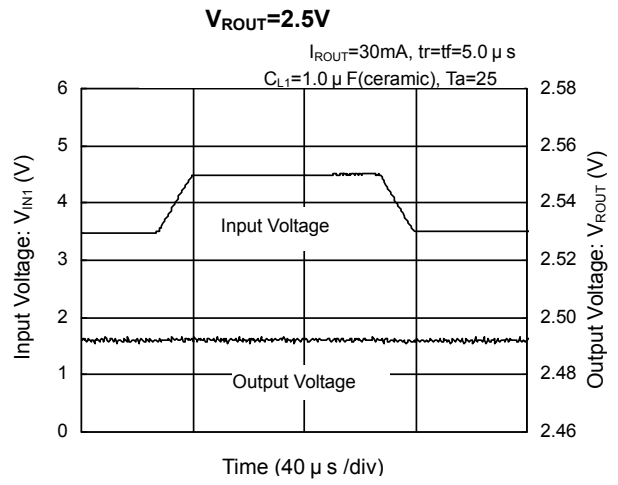
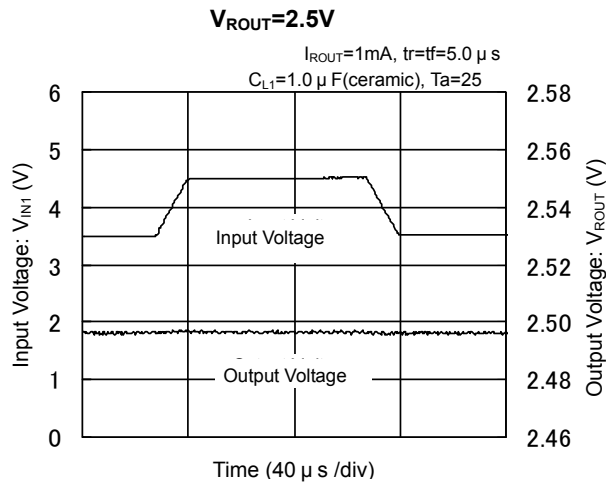

## TYPICAL PERFORMANCE CHARACTERISTICS (Continued)

### ( 12 ) Input Transient Response (Continued)

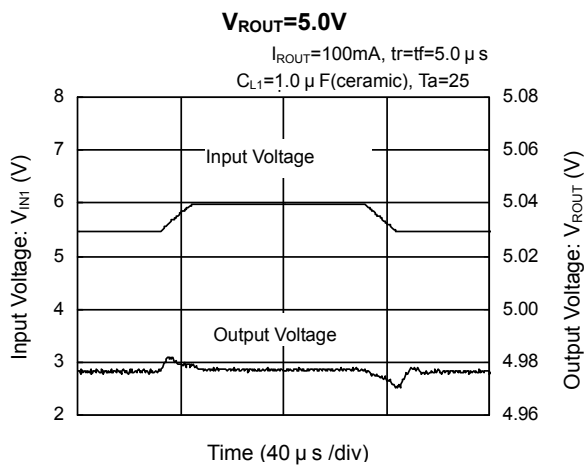
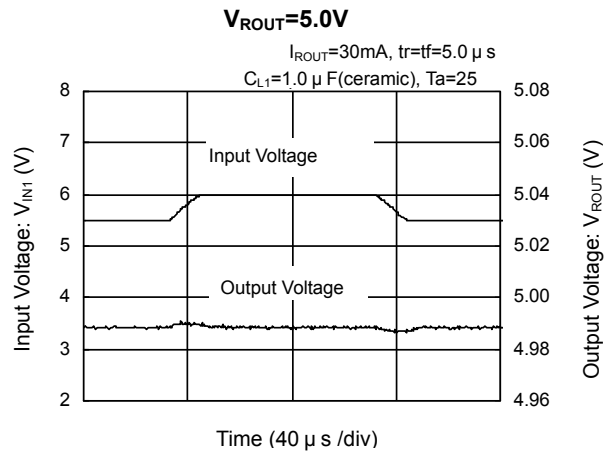
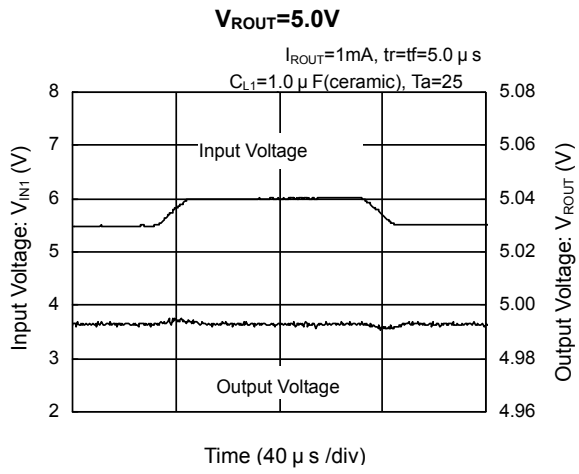

# TYPICAL PERFORMANCE CHARACTERISTICS (Continued)

## ( 13 ) Load Transient Response

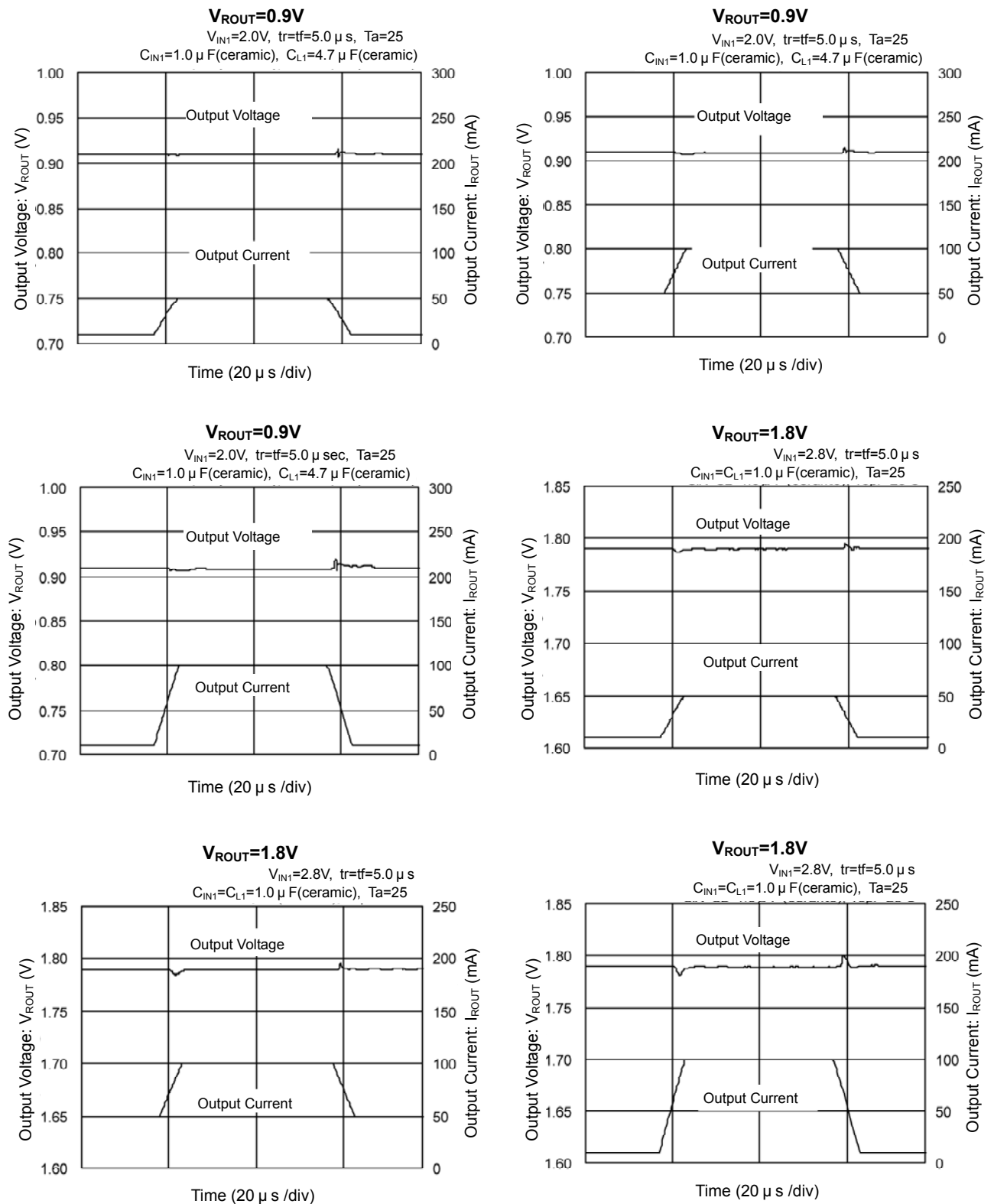

## TYPICAL PERFORMANCE CHARACTERISTICS (Continued)

### ( 13 ) Load Transient Response (Continued)

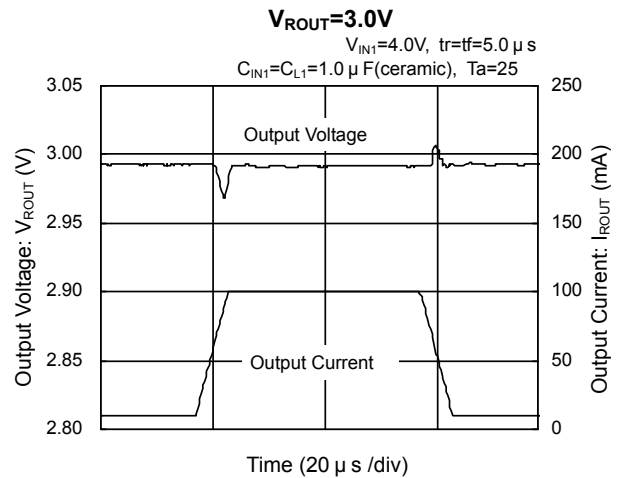
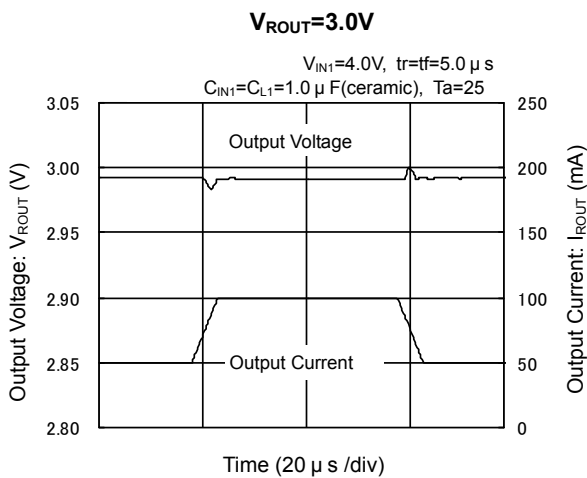
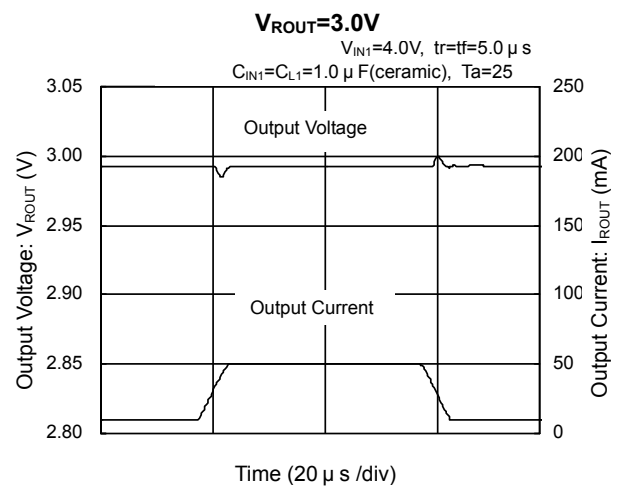
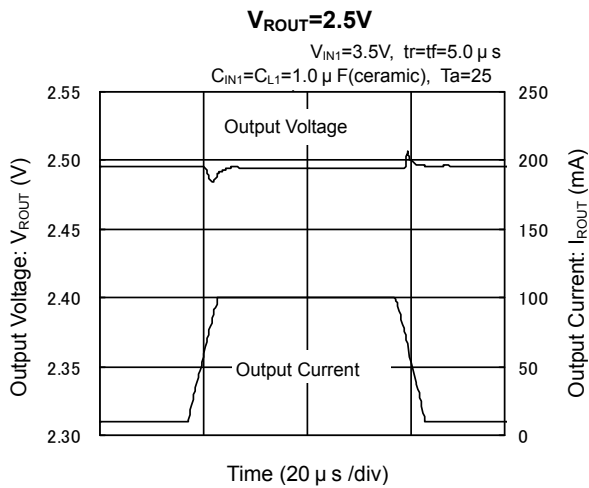
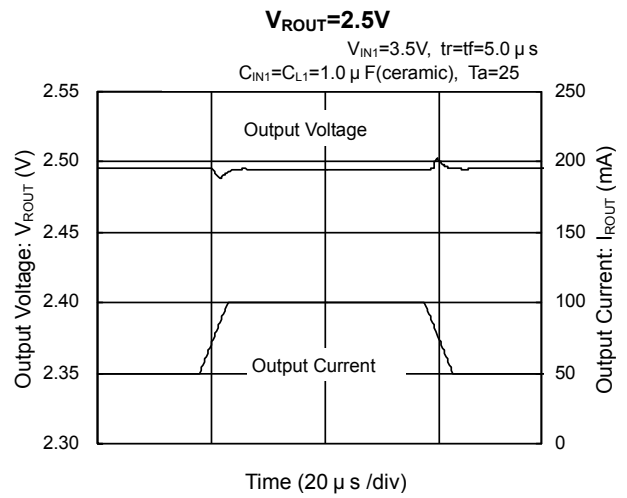
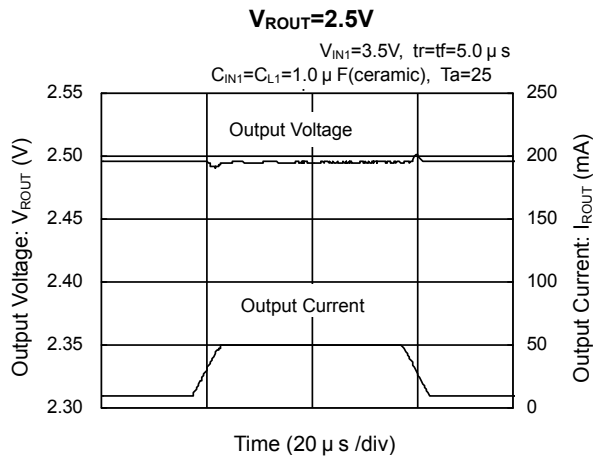

## TYPICAL PERFORMANCE CHARACTERISTICS (Continued)

### ( 13 ) Load Transient Response (Continued)

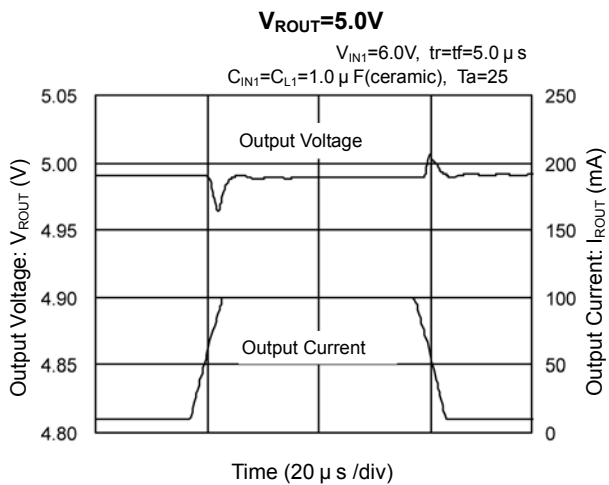
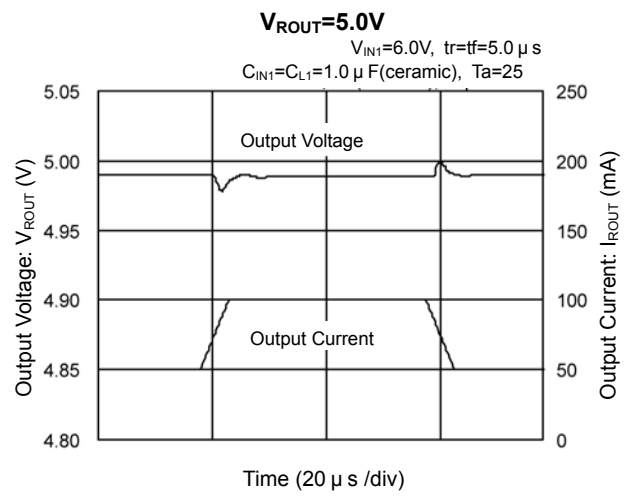
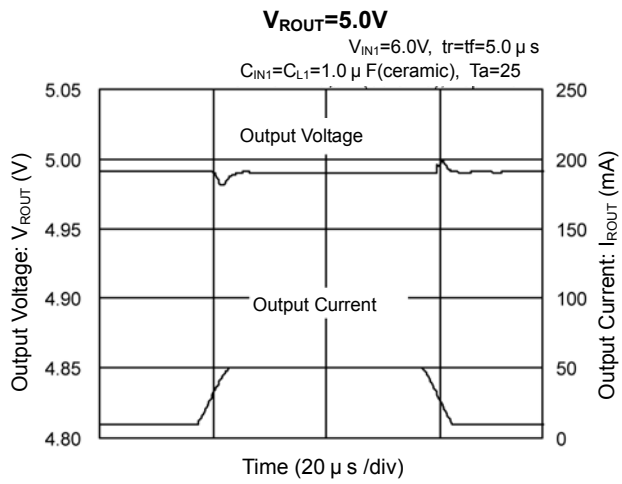

## TYPICAL PERFORMANCE CHARACTERISTICS (Continued)

### ( 14 ) Ripple Rejection Rate

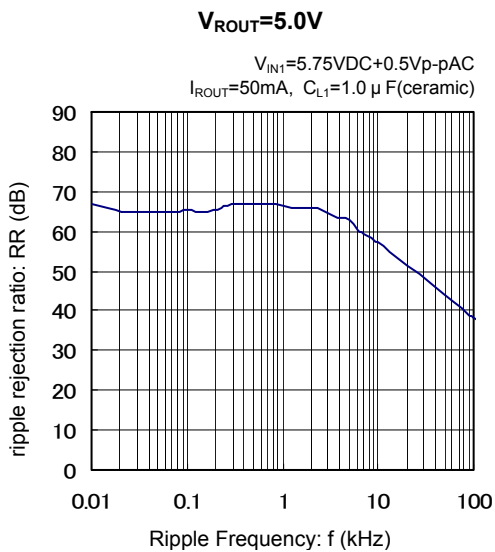
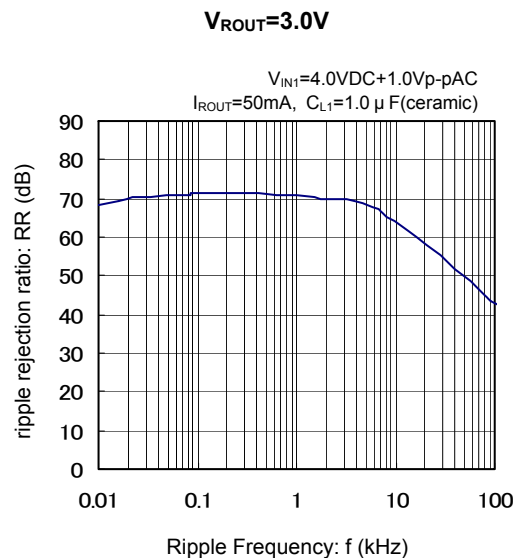
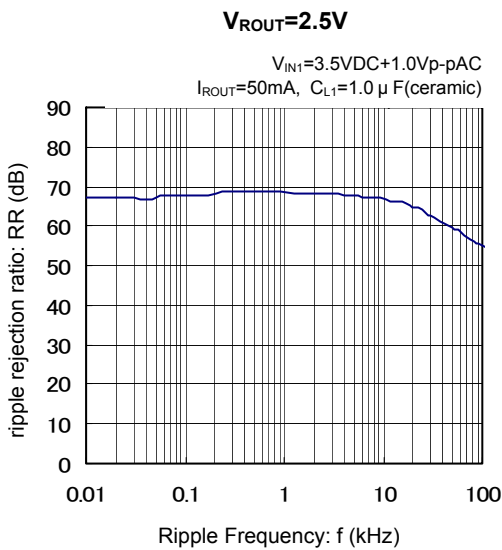
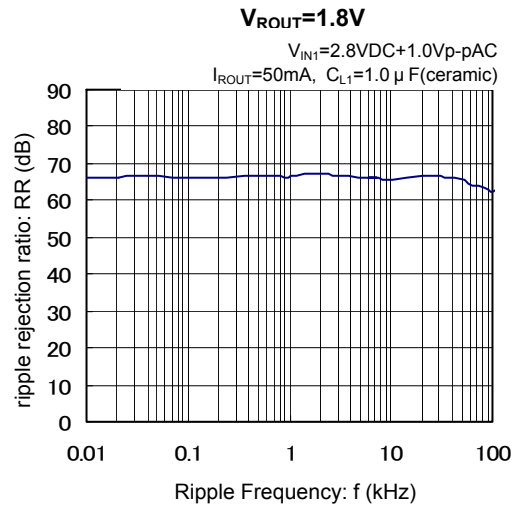
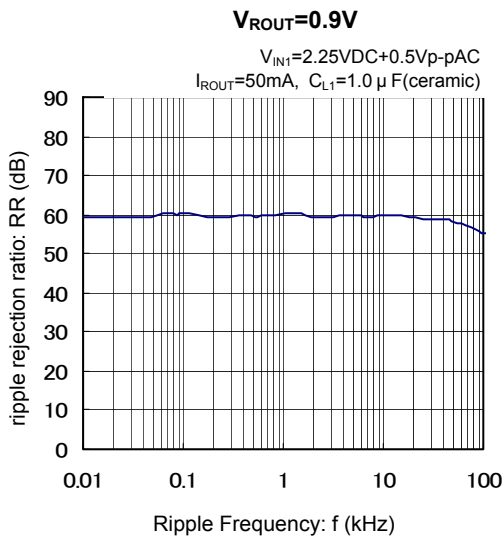

# TYPICAL PERFORMANCE CHARACTERISTICS (Continued)

## ( 15 ) Input Voltage Rising Response Time

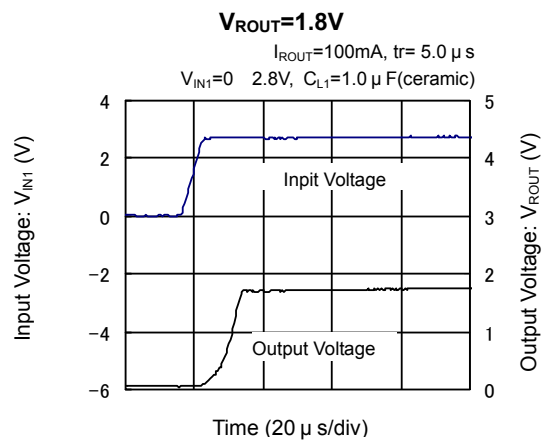
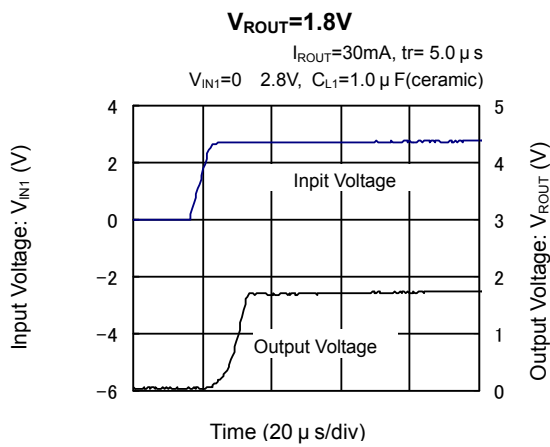
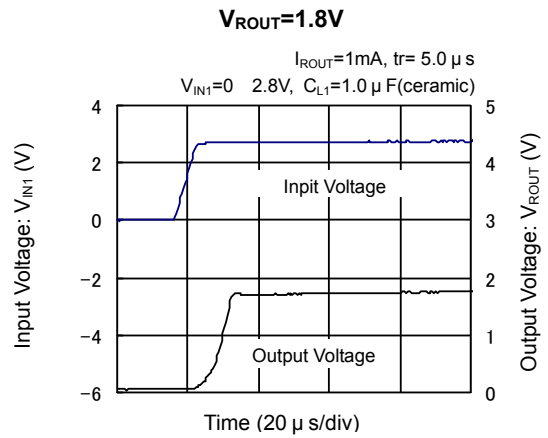
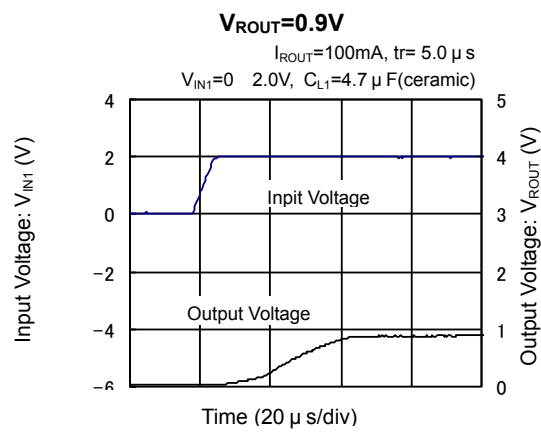
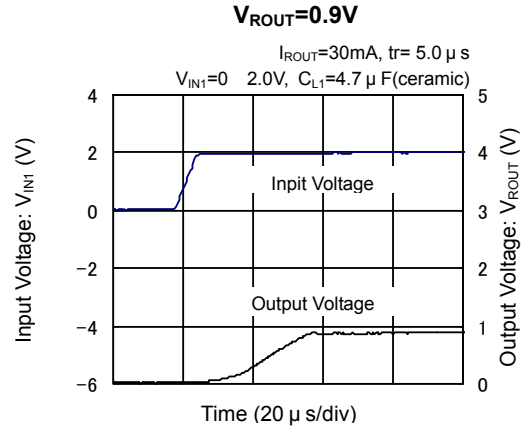
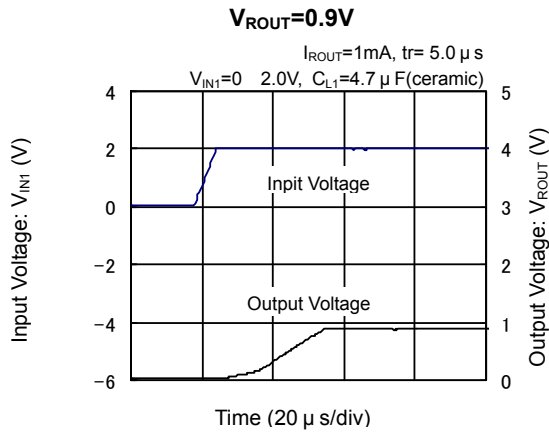

## TYPICAL PERFORMANCE CHARACTERISTICS (Continued)

### ( 15 ) Input Voltage Rising Response Time (Continued)

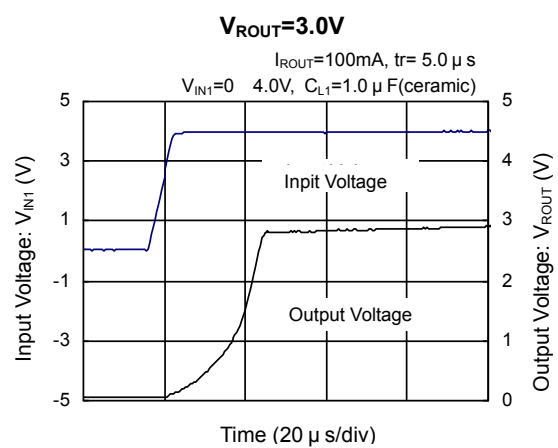
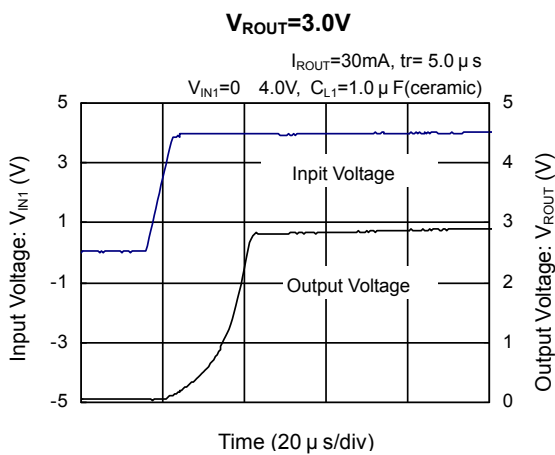
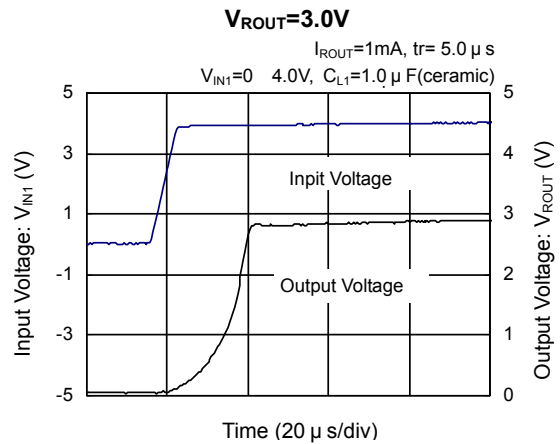
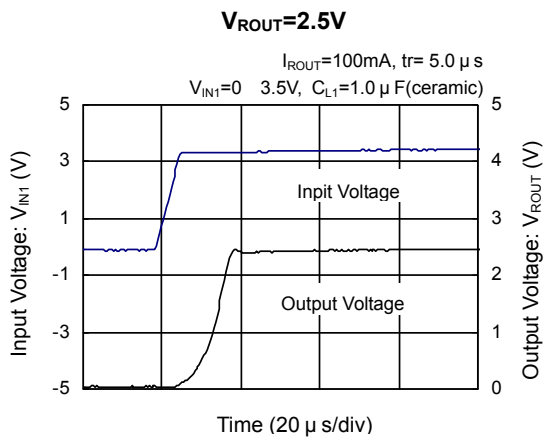
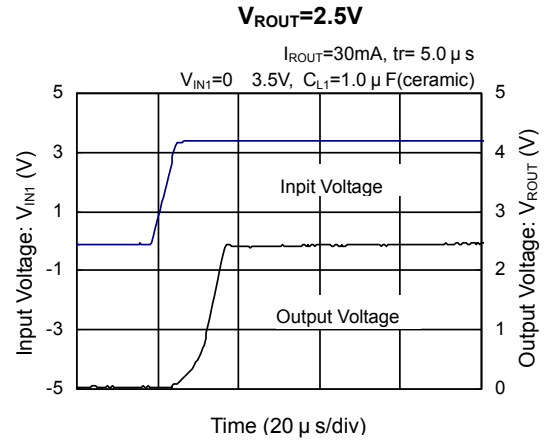
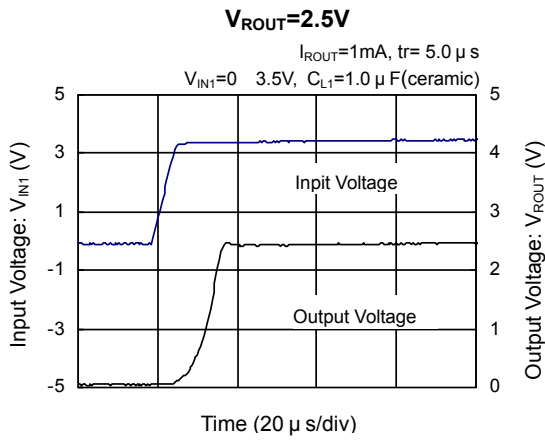



# TYPICAL PERFORMANCE CHARACTERISTICS (Continued)

## ( 15 ) Input Voltage Rising Response Time (Continued)

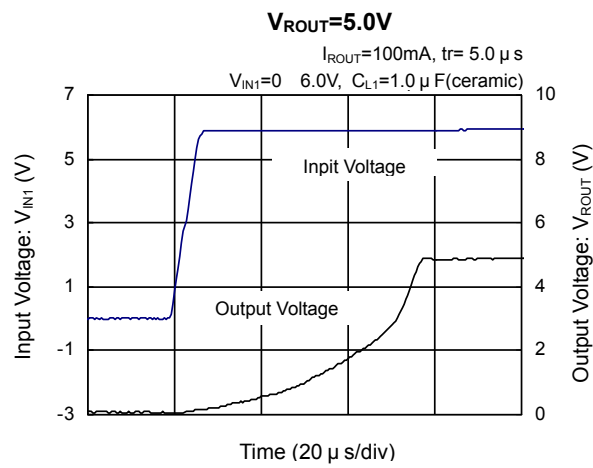
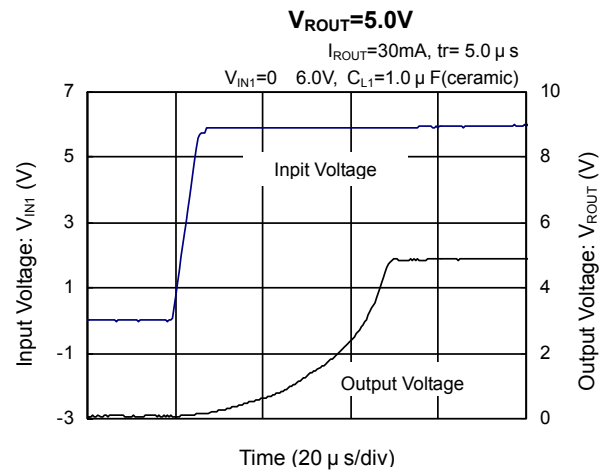
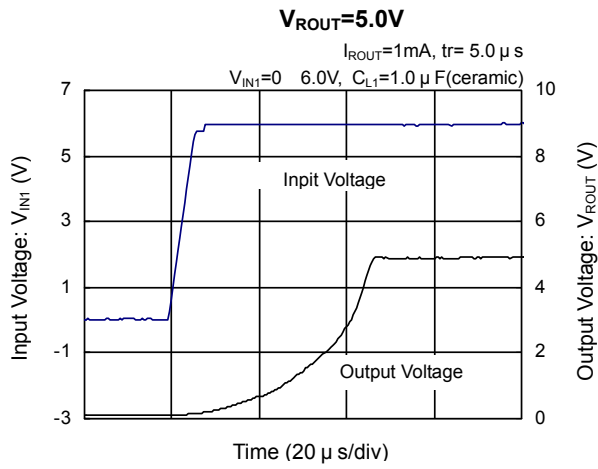

## TYPICAL PERFORMANCE CHARACTERISTICS (Continued)

2ch:DC/DC Convertor Block

### (1) Efficiency vs. Output Current

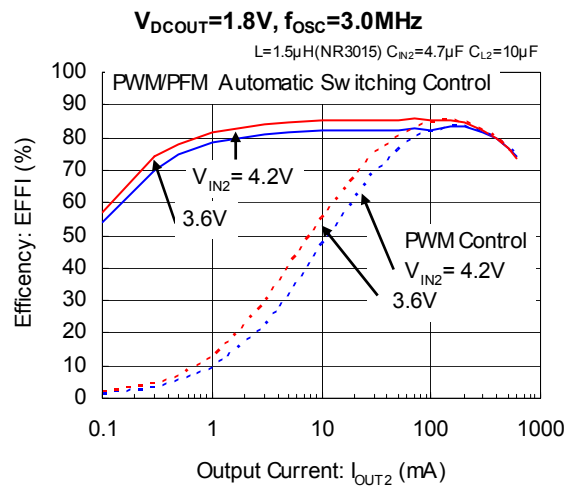
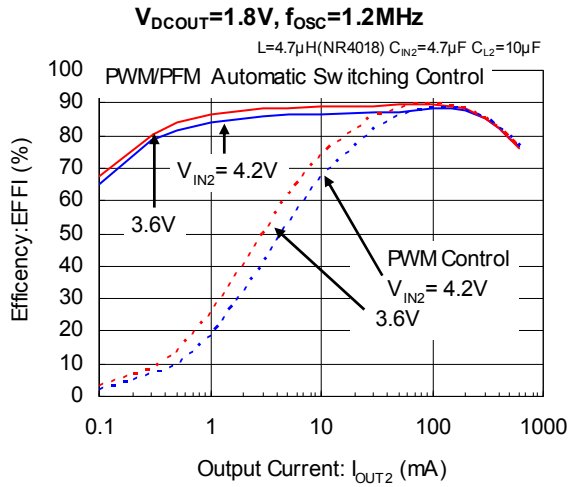

### (2) Output Voltage vs. Output Current

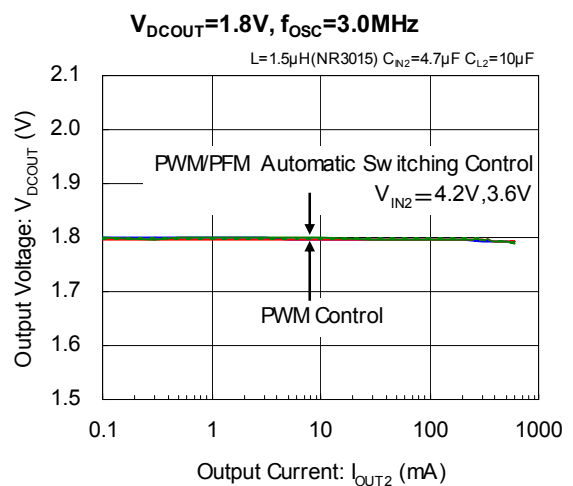
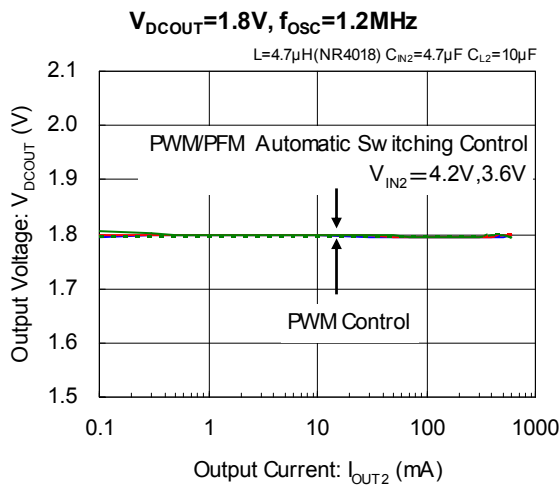

### (3) Ripple Voltage vs. Output Current

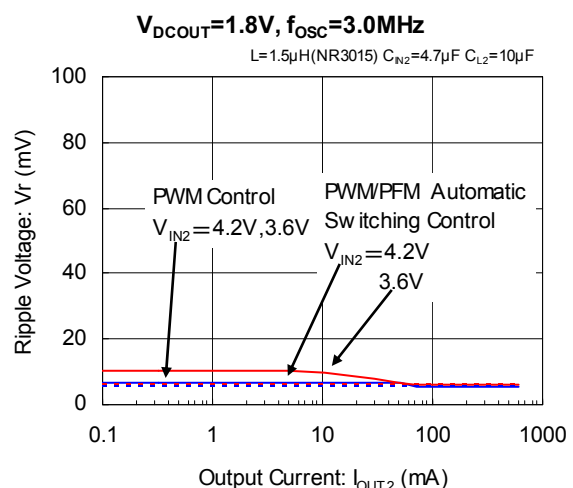
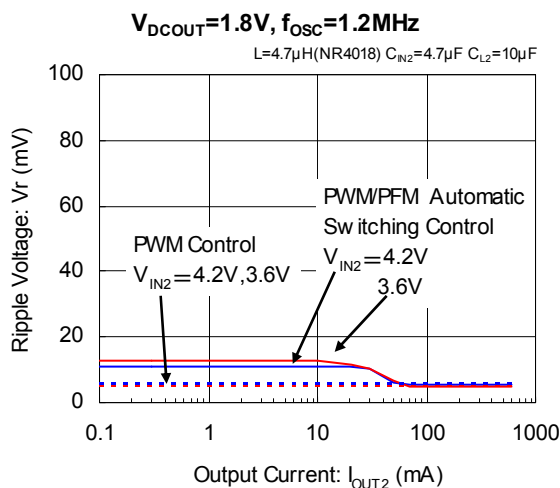

## TYPICAL PERFORMANCE CHARACTERISTICS (Continued)

(4) Oscillation Frequency vs. Ambient Temperature

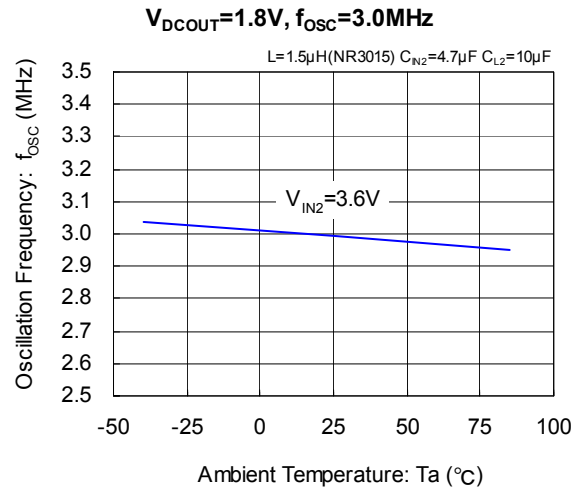
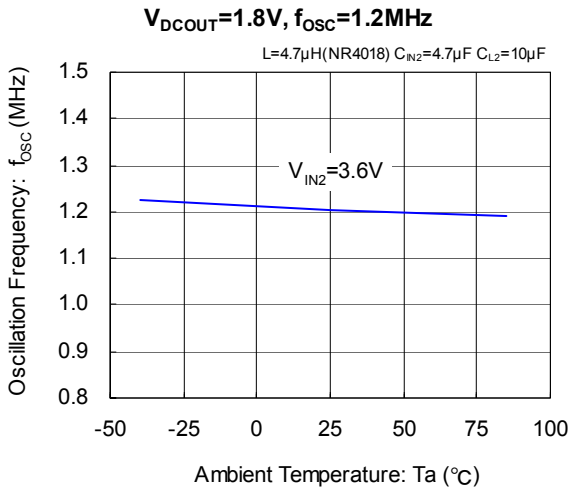

(5) Supply Current vs. Ambient Temperature

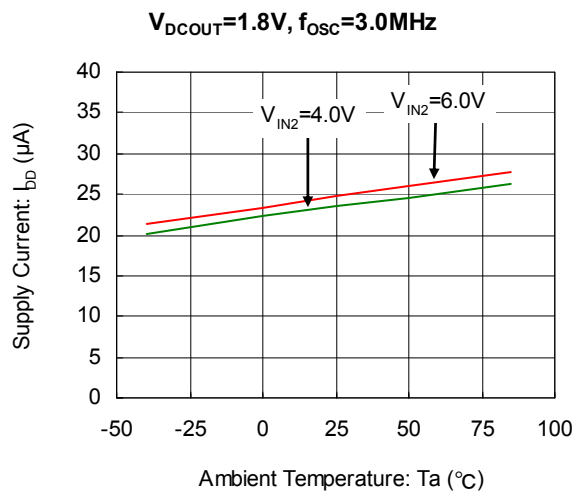
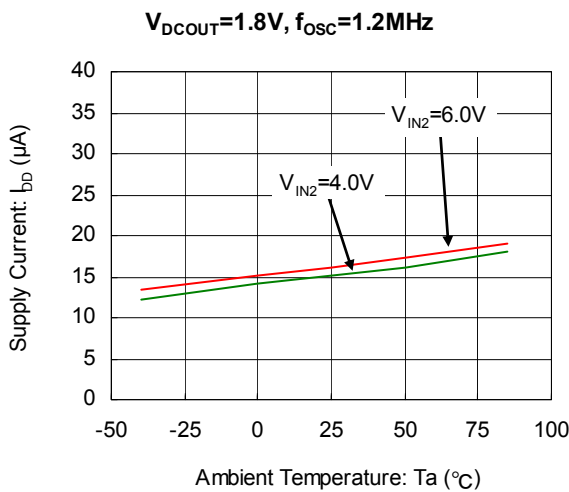

(6) Output Voltage vs. Ambient Temperature

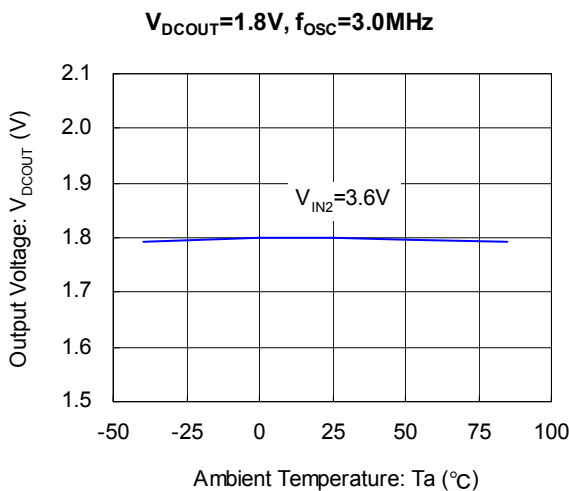

(7) UVLO Voltage vs. Ambient Temperature

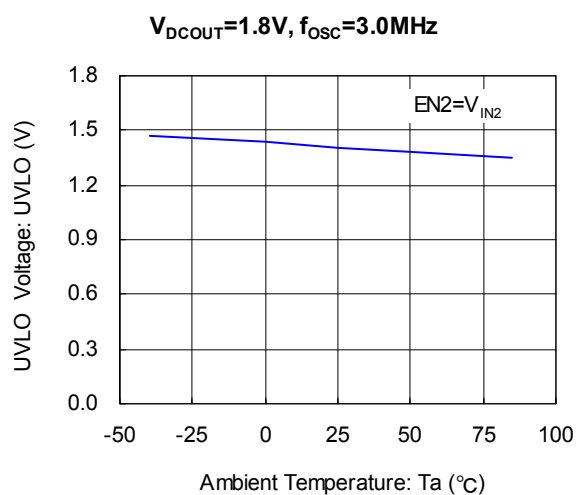

## TYPICAL PERFORMANCE CHARACTERISTICS (Continued)

(8) EN "H" Voltage vs. Ambient Temperature

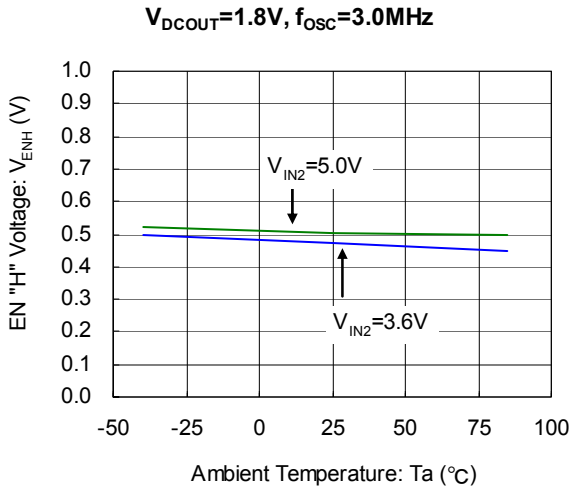

(9) EN "L" Voltage vs. Ambient Temperature

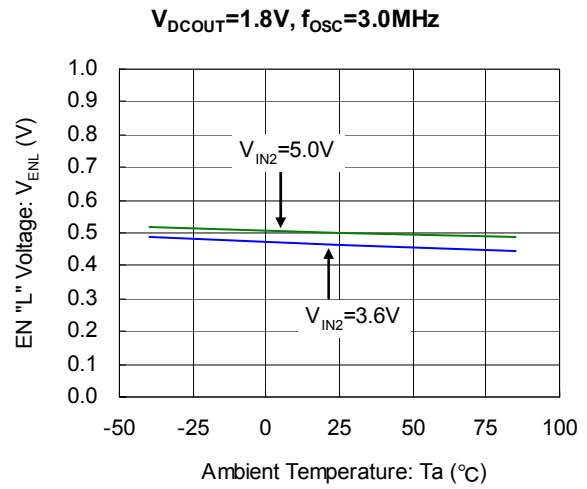

(10) Soft Start Time vs. Ambient Temperature

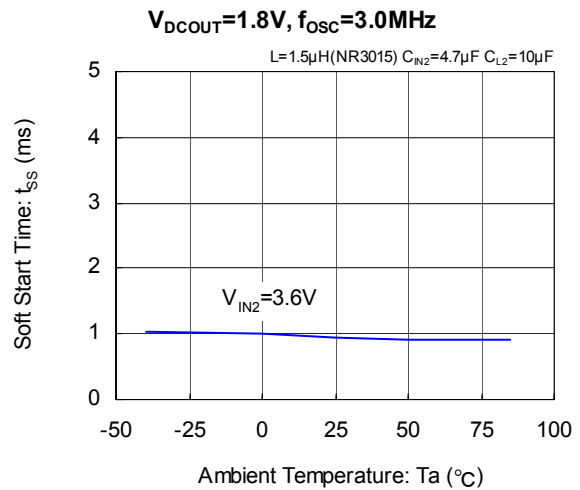
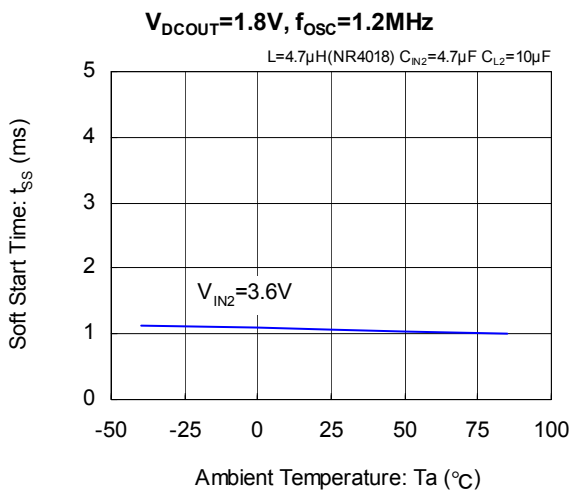

(11) "P-channel/N-channel" Driver on Resistance vs. Input Voltage

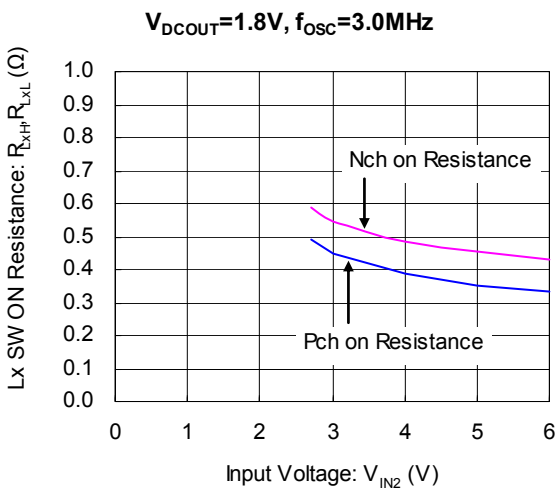

# TYPICAL PERFORMANCE CHARACTERISTICS (Continued)

(12) XCM524xC/ XCM524xD Series Rise Wave Form

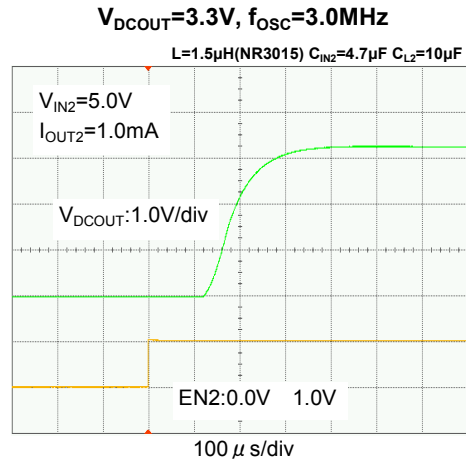
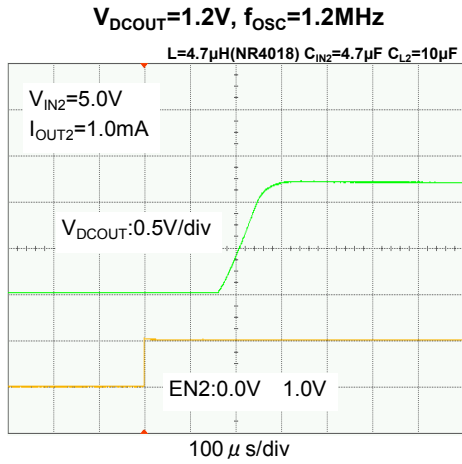

(13) XCM524xC/ XCM524xD Series Soft-Start Time vs. Ambient Temperature

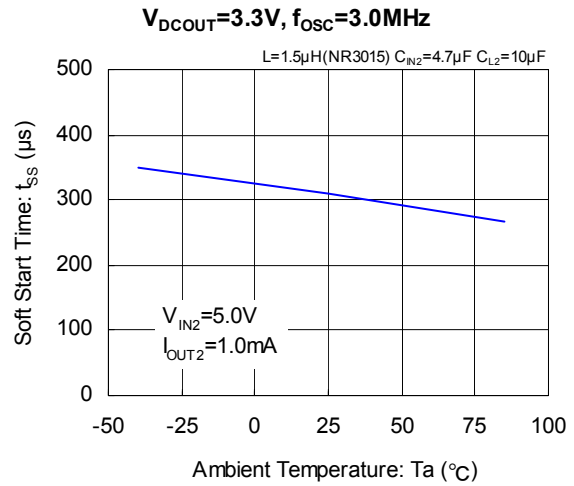
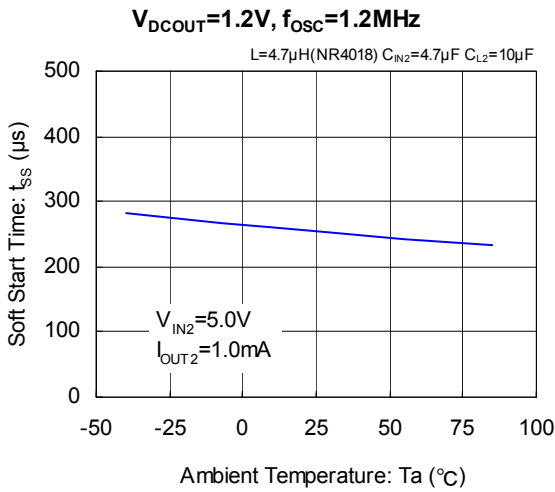

(14) XCM524xC/ XCM524xD Series CL Discharge Resistance vs. Ambient Temperature

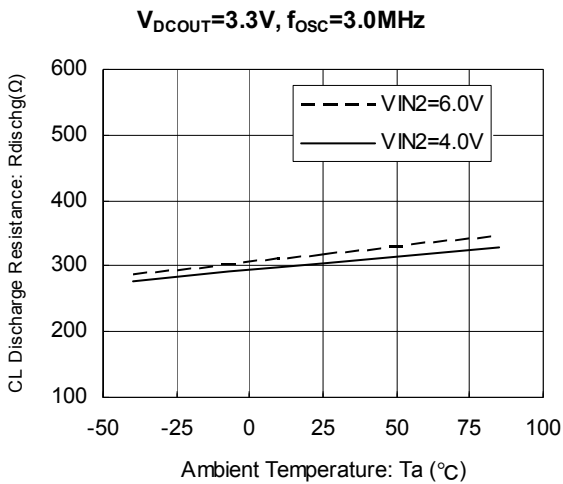

## TYPICAL PERFORMANCE CHARACTERISTICS (Continued)

### (15) Load Transient Response

$V_{DCOUT}=1.2V$ ,  $f_{OSC}=1.2MHz$ (PWM/PFM Automatic Switching Control)

$L=4.7\ \mu H$ (NR4018),  $C_{IN2}=4.7\ \mu F$ (ceramic),  $C_{L2}=10\ \mu F$ (ceramic),  $T_a=25$

$V_{IN2}=3.6V$ ,  $EN2=V_{IN2}$

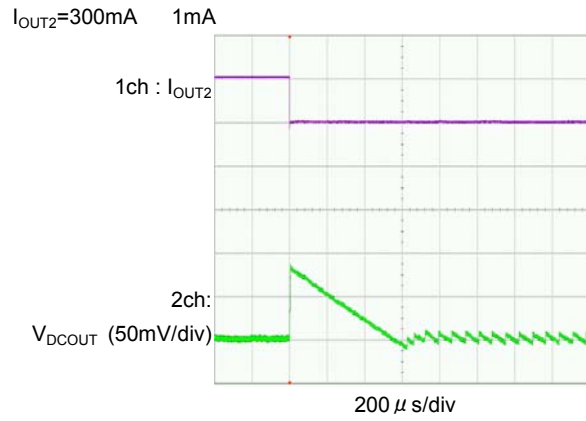
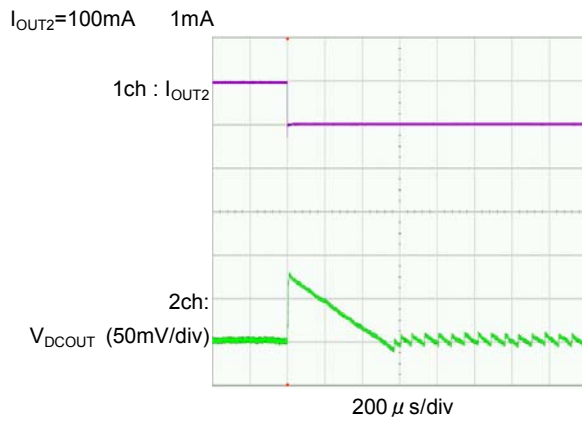
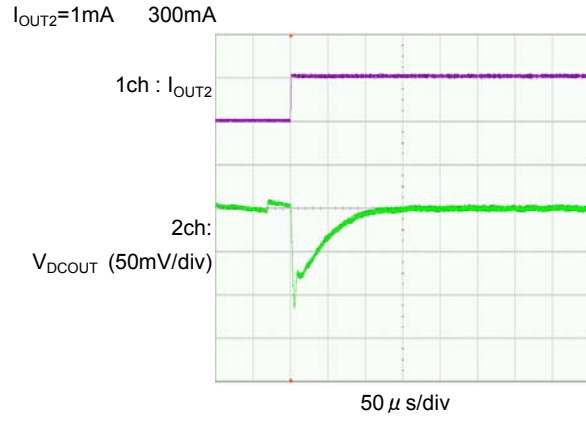
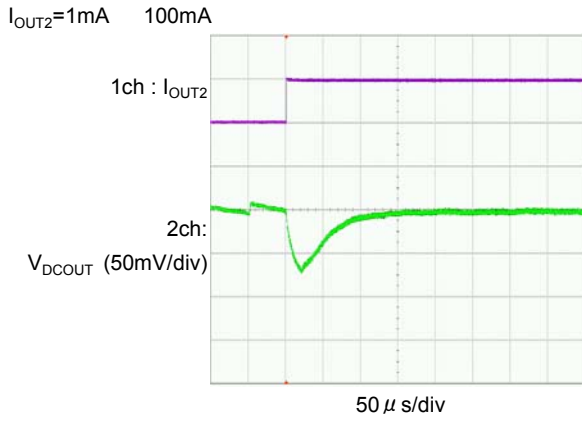

## TYPICAL PERFORMANCE CHARACTERISTICS (Continued)

### (15) Load Transient Response (Continued)

$V_{DCOUT}=1.2V$ ,  $f_{OSC}=1.2MHz$  (PWM Control)

$L=4.7\mu H$  (NR4018),  $C_{IN2}=4.7\mu F$  (ceramic),  $C_{L2}=10\mu F$  (ceramic),  $T_a=25$

$V_{IN2}=3.6V$ ,  $EN2=V_{IN2}$

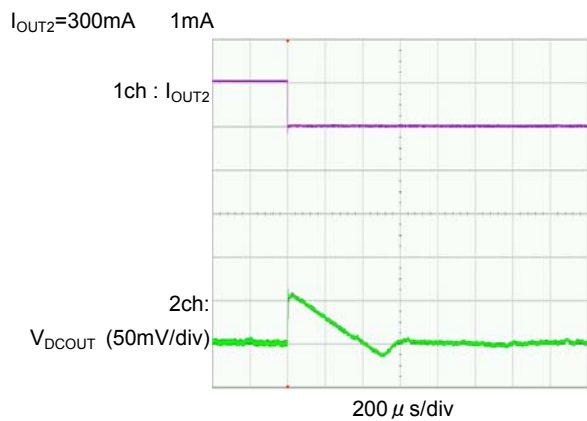
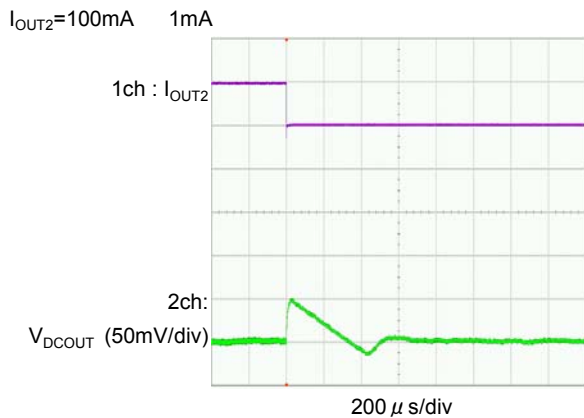
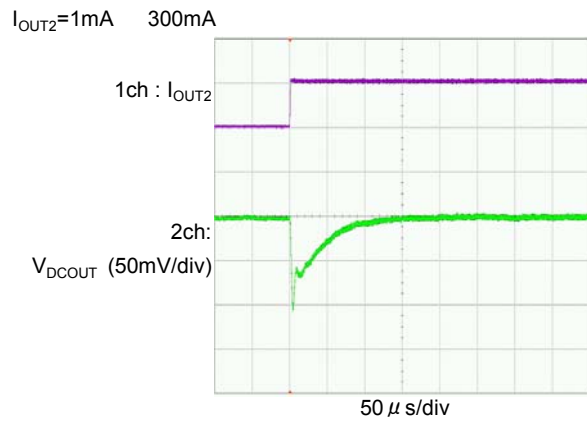
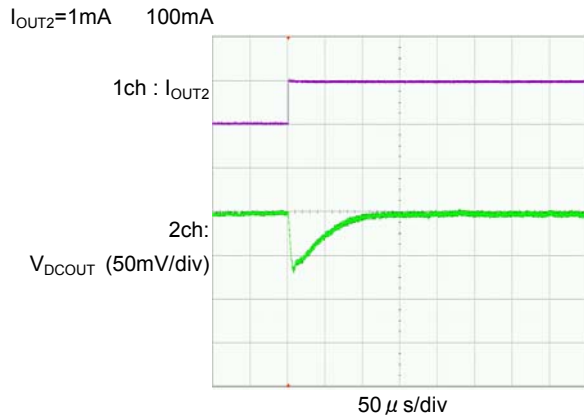

## TYPICAL PERFORMANCE CHARACTERISTICS (Continued)

### (15) Load Transient Response (Continued)

$V_{DCOUT}=1.8V$ ,  $f_{OSC}=3.0MHz$  (PWM/PFM Automatic Switching Control)

$L=1.5\mu H$ (NR3015),  $C_{IN2}=4.7\mu F$ (ceramic),  $C_{L2}=10\mu F$ (ceramic),  $T_a=25$

$V_{IN2}=3.6V$ ,  $EN=V_{IN2}$

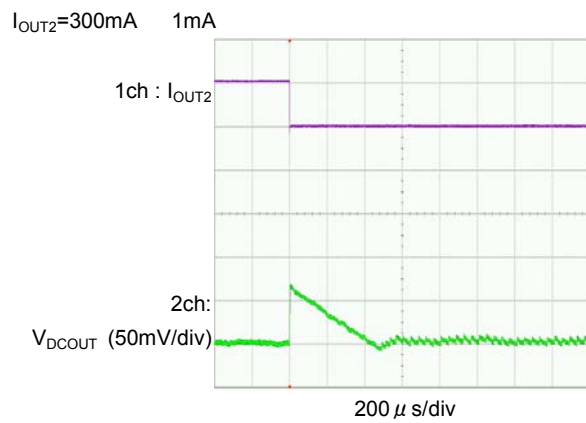
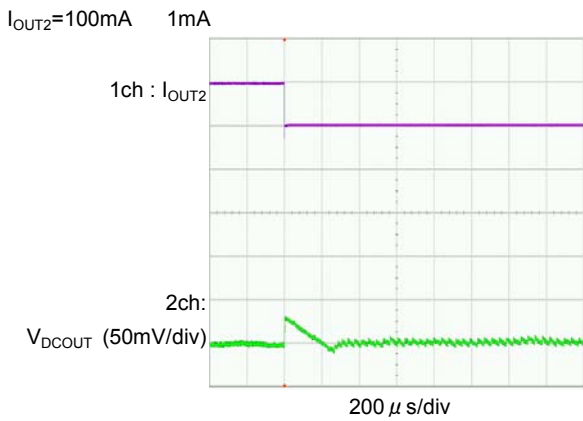
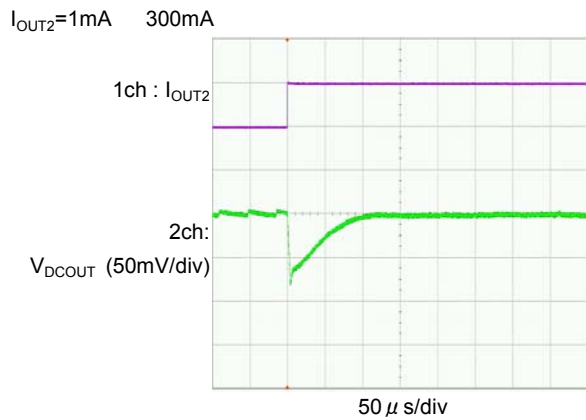
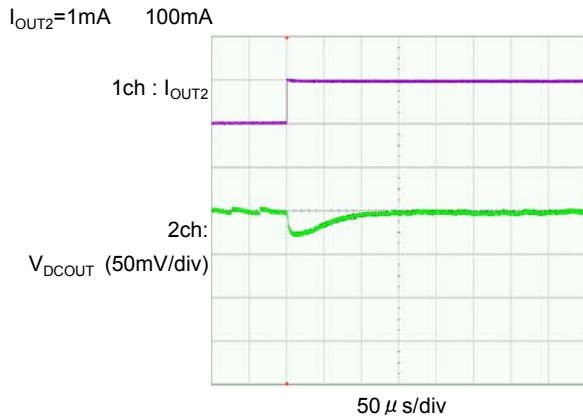



## TYPICAL PERFORMANCE CHARACTERISTICS (Continued)

### (15) Load Transient Response (Continued)

$V_{DCOUT}=1.8V$ ,  $f_{OSC}=3.0MHz$  (PWM Control)

$L=1.5\mu H$ (NR3015),  $C_{IN2}=4.7\mu F$ (ceramic),  $C_{L2}=10\mu F$ (ceramic),  $T_a=25$

$V_{IN2}=3.6V$ ,  $EN2=V_{IN2}$

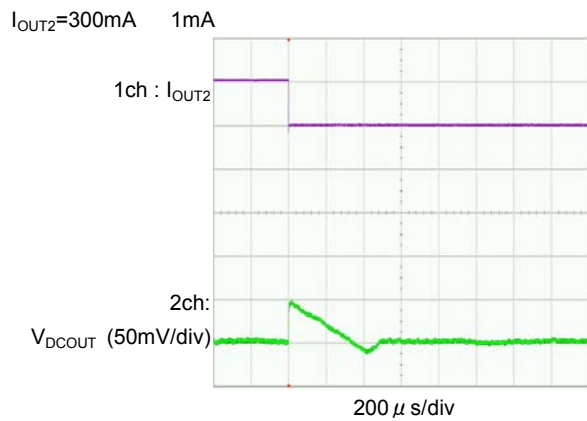
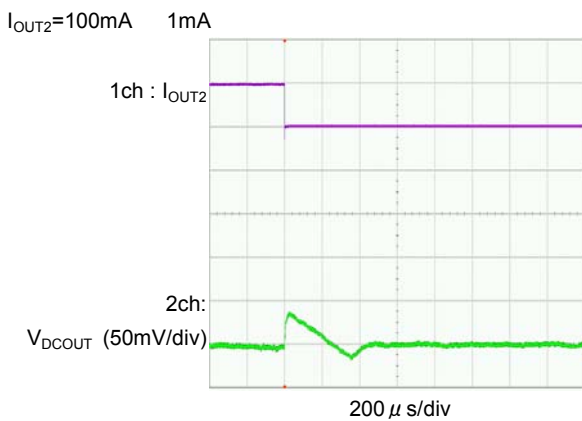
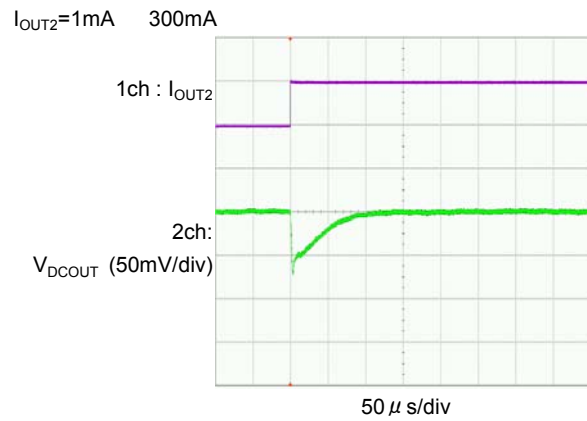
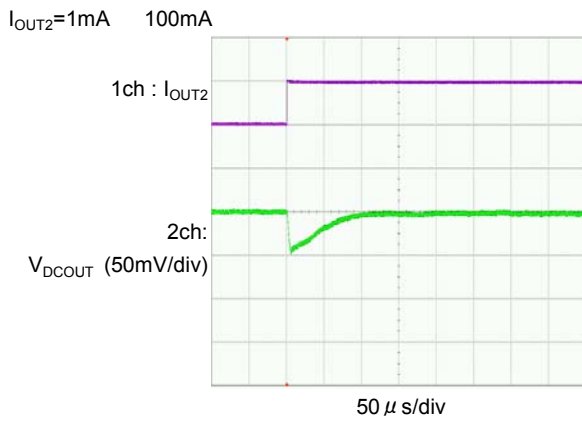

## PACKAGING INFORMATION

USP-12B01

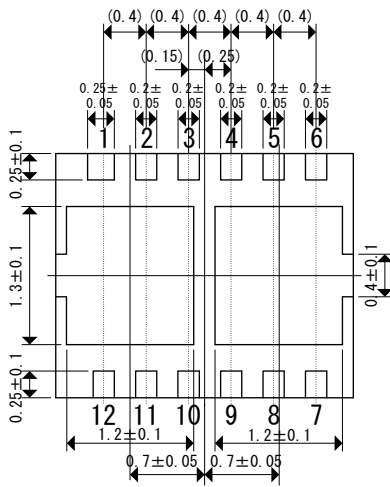
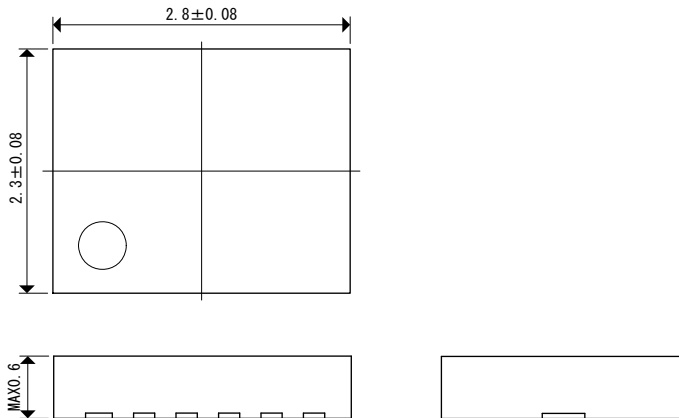

USP-12B01 Reference Pattern Layout

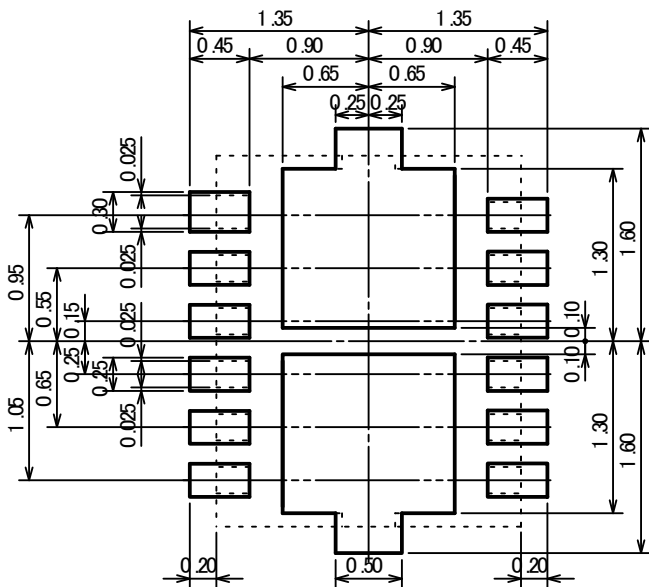

USP-12B01 Reference Metal Mask Design

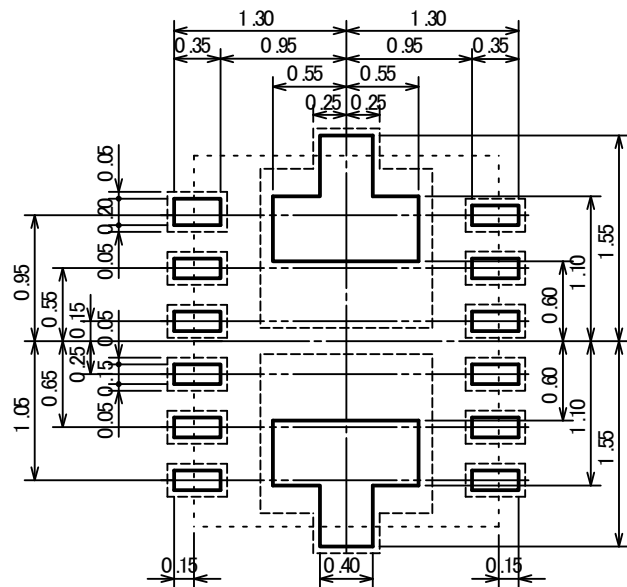

# PACKAGING INFORMATION (Continued)

## USP-12B01 Power Dissipation

Power dissipation data for the USP-12B01 is shown in this page.  
 The value of power dissipation varies with the mount board conditions.  
 Please use this data as one of reference data taken in the described condition.

### 1. Measurement Condition (Reference data)

- Condition: Mount on a board
- Ambient: Natural convection
- Soldering: Lead (Pb) free
- Board: Dimensions 40 x 40 mm (1600 mm<sup>2</sup> in one side)
- 1<sup>st</sup> Layer: Land and a wiring pattern
- 2<sup>nd</sup> Layer: Connecting to approximate 50% of the 1<sup>st</sup> heat sink
- 3<sup>rd</sup> Layer: Connecting to approximate 50% of the 2<sup>nd</sup> heat sink
- 4<sup>th</sup> Layer: Noting
- Material: Glass Epoxy (FR-4)
- Thickness: 1.6 mm
- Through-hole: 2 x 0.8 Diameter (each TAB needs one through-hole)

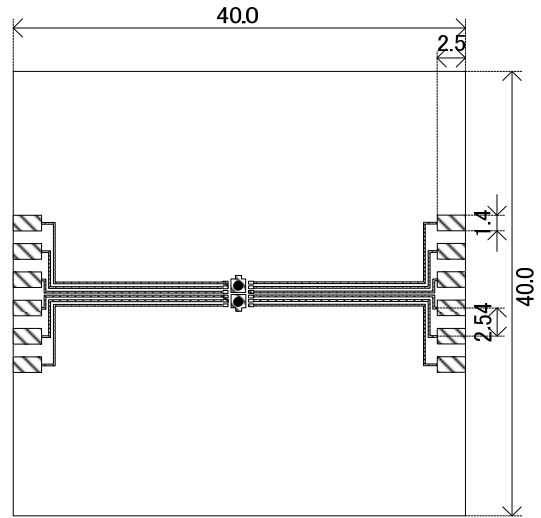

Evaluation Board (Unit: mm)

### 2. Power Dissipation vs. Ambient Temperature

Only 1ch heating, Board Mount (T<sub>j</sub> max = 125 °C)

Ambient Temperature (°C)	Power Dissipation Pd (mW)	Thermal Resistance (°C/W)
25	800	125.00
85	320	

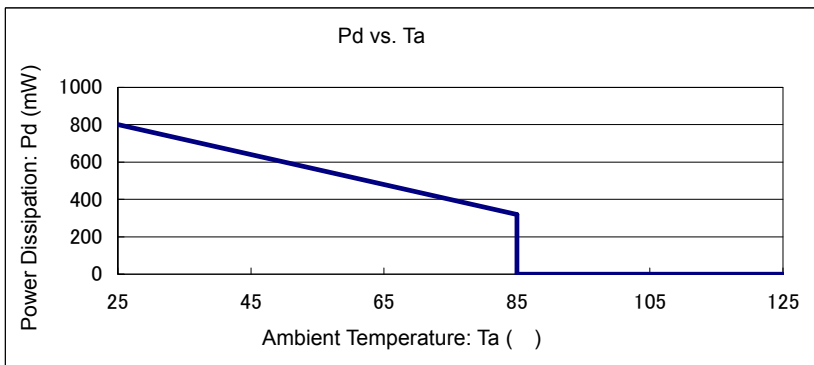

Both 2ch heating same time, Board Mount (T<sub>j</sub> max = 125 °C)

Ambient Temperature (°C)	Power Dissipation Pd (mW)	Thermal Resistance (°C/W)
25	600	166.67
85	240	

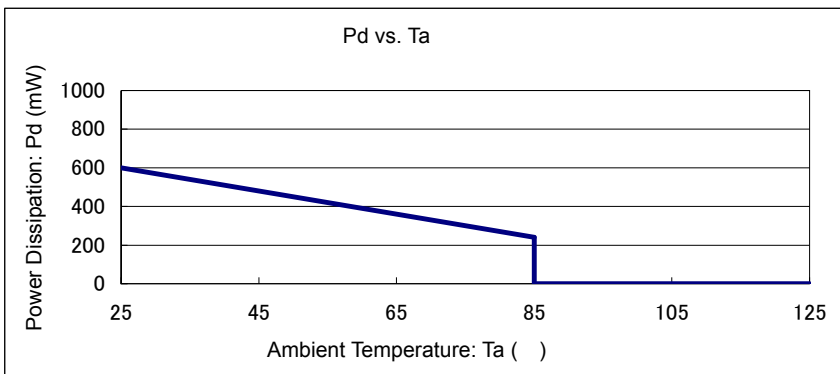

1. The products and product specifications contained herein are subject to change without notice to improve performance characteristics. Consult us, or our representatives before use, to confirm that the information in this datasheet is up to date.
2. We assume no responsibility for any infringement of patents, patent rights, or other rights arising from the use of any information and circuitry in this datasheet.
3. Please ensure suitable shipping controls (including fail-safe designs and aging protection) are in force for equipment employing products listed in this datasheet.
4. The products in this datasheet are not developed, designed, or approved for use with such equipment whose failure or malfunction can be reasonably expected to directly endanger the life of, or cause significant injury to, the user.  
(e.g. Atomic energy; aerospace; transport; combustion and associated safety equipment thereof.)
5. Please use the products listed in this datasheet within the specified ranges.  
Should you wish to use the products under conditions exceeding the specifications, please consult us or our representatives.
6. We assume no responsibility for damage or loss due to abnormal use.
7. All rights reserved. No part of this datasheet may be copied or reproduced without the prior permission of TOREX SEMICONDUCTOR LTD.

**TOREX SEMICONDUCTOR LTD.**