

32-bit Proprietary Microcontrollers

CMOS

FR30 MB91F158

MB91F158

■ DESCRIPTION

The MB91F158 is a microcontroller for CD/DVD using a RISC-CPU (FR 30 series) as its core.

■ FEATURES

1. CPU

- 32-bit RISC (FR30) , load/store architecture, 5-stage pipeline
- General-purpose registers : 32 bits × 16
- 16-bit fixed-length instructions (basic instructions) , 1 instruction/ 1 cycle
- Memory-to-memory transfer, bit processing, barrel shift processing : Optimized for embedded applications
- Function entrance/exit instructions, and multiple load/store instructions of register contents, instruction systems supporting high level languages
- Register interlock functions, efficient assembly language description
- Branch instructions with delay slots : Reduced overhead time in branching executions
- Internal multiplier/supported at instruction level
 - Signed 32-bit multiplication : 5 cycles
 - Signed 16-bit multiplication : 3 cycles
- Interrupt (PC and PS saving) : 6 cycles, 16 priority levels
- Support for little endian mode

2. Bus Interface

- 24-bit address output, 8/16-bit data input and output
- Basic bus cycle : 2-clock cycle
- Support for interface for various types of memory
- Unused data/address pins can be configured as input/output ports
- Support for little endian mode

(Continued)

■ PACKAGE

120-pin plastic LQFP

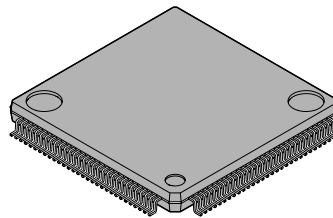

(FPT-120P-M05)

MB91F158

3. Internal ROM

FLASH products : 510 Kbytes

4. Internal RAM

2 Kbytes

5. Internal Data RAM

6 Kbytes

6. Bit Search Module

Searches in one cycle for the position of the bit that changes from the MSB in one word to the initial I/O.

7. Timers

- 16-bit OCU × 4 channels, ICU × 4 channels, Free-run timer × 1 channel
- 8/16-bit up/down timer/counter (8-bit × 2 channels or 16-bit × 1 channel)
- 16-bit PPG timer × 4 channels. The output pulse cycle and duty can be varied as desired
- 16-bit reload timer × 2 channels

8. D/A Converter

- 8-bit × 3 channels

9. A/D Converter (Sequential Comparison Type)

- 10-bit × 8 channels
- Sequential conversion method (conversion time : 5.2 μs@32 MHz)
- Single conversion or scan conversion can be selected, and one-shot or continuous or stop conversion mode can be set respectively.
- Conversion starting function by hardware/software.

10. Serial I/O

- UART × 2 channels. Any of them is capable of serial transfer in sync with clock attached with the LSB/MSB switching function.
- Serial data output and serial clock output are selectable by push-pull/open drain software.
- A 16-bit timer (U-timer) is contained as a dedicated baud rate generator allowing any baud rate to be generated.

11. Clock Switching Function

- Gear function : Operating clock ratios to the basic clock can be set independently for the CPU and peripherals from four types, 1 : 1, 1 : 2, 1 : 4 or 1 : 8.

12. Interrupt Controller

External interrupt input (16 channels in total) :

- Allows the rising edge/falling edge/H level/L level to be set.

Internal interrupt factors :

- Interrupt by resources and delay interrupt

13. Others

- Reset cause : Power on reset/watchdog timer/software reset/external reset
- Low power consumption mode : Sleep/stop
- Package : 120-pin LQFP
- CMOS technology (0.35 μm)
- Power supply voltage : 3.2 V to 3.5 V
- Operation frequency upper limit
 - CPU : 32 MHz
 - Peripheral circuit : 32 MHz
 - External bus : 25 MHz

PIN ASSIGNMENT

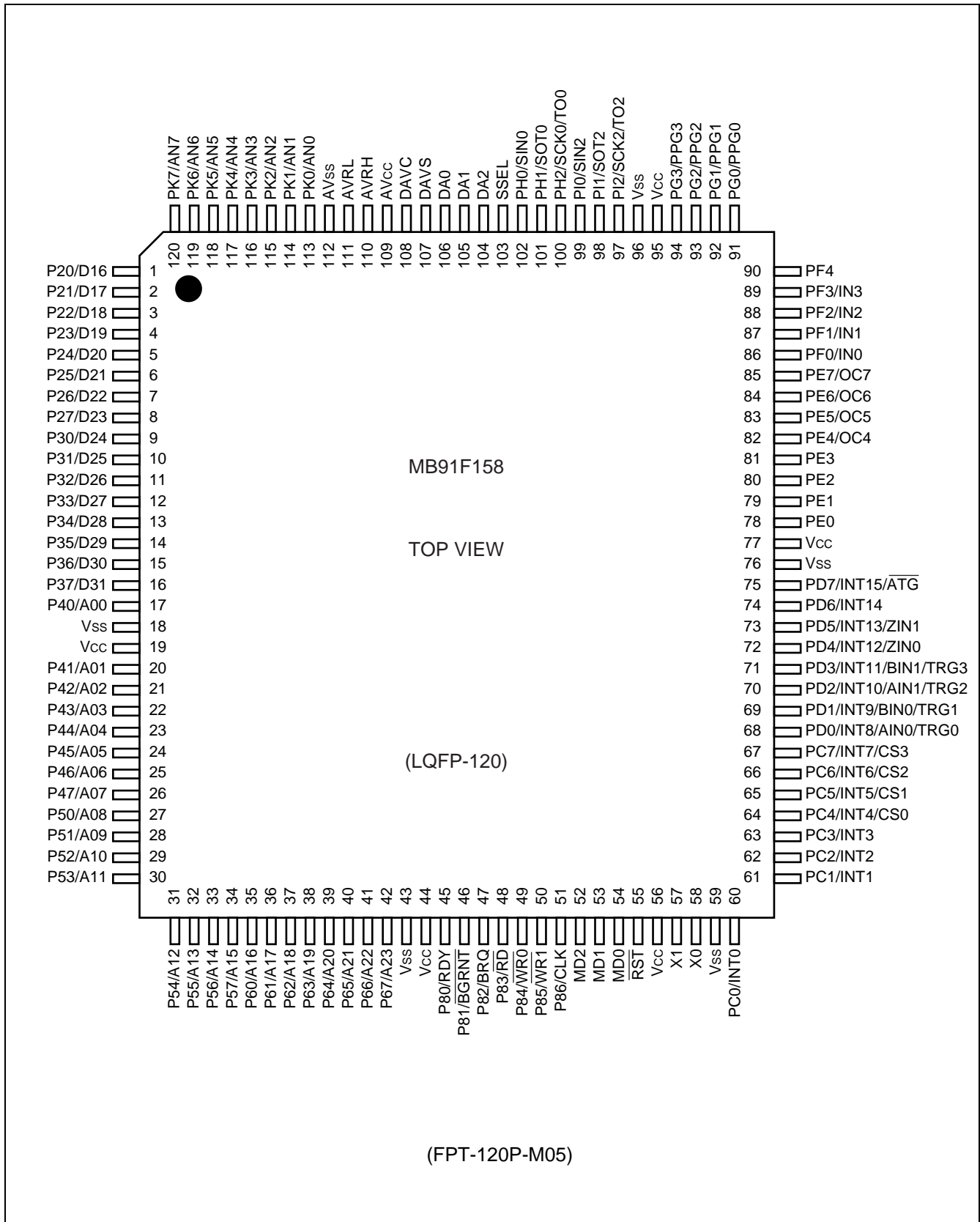

MB91F158

■ PIN DESCRIPTION

Pin No.	Pin name	Circuit type	Function
1 2 3 4 5 6 7 8	D16/P20 D17/P21 D18/P22 D19/P23 D20/P24 D21/P25 D22/P26 D23/P27	C	Bit 16 to bit 23 of external data bus These pins are enabled only in 16-bit external bus mode. These pins are available as ports in single-chip and 8-bit external bus modes.
9 10 11 12 13 14 15 16	D24/P30 D25/P31 D26/P32 D27/P33 D28/P34 D29/P35 D30/P36 D31/P37	C	Bit 24 to bit 31 of external data bus These pins are available as ports in single-chip mode.
17 20 21 22 23 24 25 26 27 28 29 30 31 32 33 34	A00/P40 A01/P41 A02/P42 A03/P43 A04/P44 A05/P45 A06/P46 A07/P47 A08/P50 A09/P51 A10/P52 A11/P53 A12/P54 A13/P55 A14/P56 A15/P57	F	Bit 0 to bit 15 of external address bus These pins are enabled in external bus mode. These pins are available as ports in single-chip mode.
35 36 37 38 39 40 41 42	A16/P60 A17/P61 A18/P62 A19/P63 A20/P64 A21/P65 A22/P66 A23/P67	O	Bit 16 to bit 23 of external address bus These pins are available as ports when the address bus is not in use.
45	RDY/P80	C	External RDY input This function is enabled when external RDY input is allowed. Input "0" when the bus cycle being executed does not end. This pin is available as a port when external RDY input is not in use.

(Continued)

Pin No.	Pin name	Circuit type	Function
46	$\overline{\text{BGRNT}}/\text{P81}$	F	External bus release acceptance output This function is enabled when external bus release acceptance output is allowed. Output "L" upon releasing of the external bus. This pin is available as a port when external bus release acceptance output is not allowed.
47	BRQ/P82	C	External bus release request input This function is enabled when external bus release request input is allowed. Input "1" when the release of the external bus is desired. This pin is available as a port when external bus release request input is not in use.
48	$\overline{\text{RD}}/\text{P83}$	F	External bus read strobe output This function is enabled when external bus read strobe output is allowed. This pin is available as a port when external bus read strobe output is not allowed.
49	$\overline{\text{WR0}}/\text{P84}$	F	External bus write strobe output This function is enabled in external bus mode. This pin is available as a port in single chip mode.
50	$\overline{\text{WR1}}/\text{P85}$	F	External bus write strobe output This function is enabled in external bus mode when the bus width is 16 bits. This pin is available as a port in single chip mode or when the external bus width is 8 bits.
51	CLK/P86	F	System clock output The pin outputs the same clock as the external bus operating frequency. The pin is available as a port when it is not used to output the clock.
52 53 54	MD2 MD1 MD0	G	Mode pins To use these pins, connect them directly to either V_{CC} or V_{SS} . Use these pins to set the basic MCU operating mode.
55	$\overline{\text{RST}}$	B	External reset input
57 58	X1 X0	A	High-speed clock oscillation pins
60 61 62 63	INT0/PC0 INT1/PC1 INT2/PC2 INT3/PC3	H	External interrupt request input 0-3 Since this input is used more or less continuously when the corresponding external interrupt is allowed, output by the port needs to be stopped except when it is performed deliberately. Since this port is allowed to input also in standby mode, it can be used to reset the standby state. These pins are available as ports when external interrupt request input is not in use.

(Continued)

MB91F158

Pin No.	Pin name	Circuit type	Function
64 65 66 67	INT4/PC4/CS0 INT5/PC5/CS1 INT6/PC6/CS2 INT7/PC7/CS3	H	<p>These pins also serve as the chip select output and external interrupt request input 4-7.</p> <p>When the chip select output is not allowed, these pins are available as external interrupt requests or ports.</p> <p>Since this input is used more or less continuously when the corresponding external interrupt is allowed, output by the port needs to be stopped except when it is performed deliberately.</p> <p>Since this port is also allowed to input in standby mode, the port can be used to reset the standby state.</p> <p>These pins are available as ports when external interrupt request input and chip select output are not in use.</p>
68 69 70 71 72 73	PD0/AIN0/INT8/TRG0 PD1/BIN0/INT9/TRG1 PD2/AIN1/INT10/TRG2 PD3/BIN1/INT11/TRG3 PD4/ZIN0/INT12 PD5/ZIN1/INT13	H	<p>External interrupt request input 8-13</p> <p>Since this input is used more or less continuously when the corresponding external interrupt is allowed, output by the port needs to be stopped except when it is performed deliberately.</p> <p>[AIN, BIN] Up/down timer input.</p> <p>[TRG] PPG external trigger input.</p> <p>Since this input is used more or less continuously while input is allowed, output by the port needs to be stopped except when it is performed deliberately.</p> <p>These pins are available as ports when the external interrupt request input, up timer counter input, and PPG external trigger input are not in use.</p>
74	PD6/INT14	H	<p>External interrupt request input 14</p> <p>Since this input is used more or less continuously when the corresponding external interrupt is allowed, output by the port needs to be stopped except when it is performed deliberately.</p>
75	PD7/ $\overline{\text{ATG}}$ /INT15	H	<p>External interrupt request input 15</p> <p>Since this input is used more or less continuously when the corresponding external interrupt is allowed, output by the port needs to be stopped except when it is performed deliberately.</p> <p>[$\overline{\text{ATG}}$] A/D converter external trigger input</p> <p>Since this input is used more or less continuously when selected as an A/D activation factor, output by the port needs to be stopped except when it is performed deliberately.</p> <p>This pin is available as a port when it is not in use as the external interrupt request input or DMA external transfer end output.</p>
78 79 80 81	PE0 PE1 PE2 PE3	F	General-purpose I/O ports
82 83 84 85	PE4/OC4 PE5/OC5 PE6/OC6 PE7/OC7	F	<p>Output compare output</p> <p>These pins are available as ports when output compare output is not allowed.</p>

(Continued)

Pin No.	Pin name	Circuit type	Function
86 87 88 89	PF0/IN0 PF1/IN1 PF2/IN2 PF3/IN3	F	Input capture input This function is enabled when the input capture operation is input. These pins are available as ports when input capture input is not in use.
90	PF4	F	General purpose I/O port
91 92 93 94	PG0/PPG0 PG1/PPG1 PG2/PPG2 PG3/PPG3	F	PPG timer output This function is enabled when PPG timer output is allowed. These pins are available as ports when PPG timer output is not allowed.
97	PI2/SCK2/TO2	P	UART2 clock I/O, Reload timer 2 output When UART2 clock output is not allowed, reload timer 2 can be output by allowing it. This pin is available as a port when neither UART2 clock output nor reload timer output is allowed.
98	PI1/SOT2	P	UART2 data output This function is enabled when UART2 data output is allowed. This pin is available as a port when UART2 clock output is not allowed.
99	PI0/SIN2	P	UART2 data input Since this input is used more or less continuously while UART2 is engaged in input operations, output by the port needs to be stopped except when it is performed deliberately. This pin is available as a port when UART2 data input is not in use.
100	PH2/SCK0/TO0	P	UART0 clock I/O, Reload timer 0 output When UART0 clock output is not allowed, reload timer 0 can be output by allowing it. This pin is available as a port when neither UART0 clock output nor reload timer output is allowed.
101	PH1/SOT0	P	UART0 data output This function is enabled when UART0 data output is allowed. This pin is available as a port when UART0 clock output is not allowed.
102	PH0/SIN0	P	UART0 data input Since this input is used more or less continuously while UART0 is engaged in input operations, output by the port needs to be stopped except when it is performed deliberately. This pin is available as a port when UART0 data input is not in use.
103	SSEL	G	Sector mode switching pin of FLASH This pin should be connected to V _{CC} or V _{SS} .
104 105 106	DA2 DA1 DA0	—	D/A converter output This function is enabled when D/A converter output is allowed.
107	DAVS	—	Power supply pin for D/A converter
108	DAVC	—	Power supply pin for D/A converter
109	AVCC	—	V _{CC} power supply pin for A/D converter

(Continued)

MB91F158

(Continued)

Pin No.	Pin name	Circuit type	Function
110	AVRH	—	A/D converter reference voltage (high potential side) Be sure to turn on/off this pin with potential higher than AVRH applied to V _{CC} .
111	AVRL	—	A/D converter reference voltage (low potential side)
112	AVSS	—	V _{SS} pin for A/D converter.
113 114 115 116 117 118 119 120	AN0/PK0 AN1/PK1 AN2/PK2 AN3/PK3 AN4/PK4 AN5/PK5 AN6/PK6 AN7/PK7	N	A/D converter analog input These pins are enabled when the AIC register is designated for analog input. These pins are available as ports when A/D converter analog input is not in use.
19, 44, 56, 77, 95	V _{CC}	—	Power supply pin (V _{CC}) for digital circuit Always power supply pin (V _{CC}) must be connected to the power supply.
18, 43, 59, 76, 96	V _{SS}	—	Earth level (V _{SS}) for digital circuit Always power supply pin (V _{SS}) must be connected to the power supply.

Note : On the majority of pins listed above, the I/O port and the resource I/O are multiplexed, such as XXXX/Pxx.
When the port and the resource output compete against each other on these pins, priority is given to the resource.

■ I/O CIRCUIT TYPE

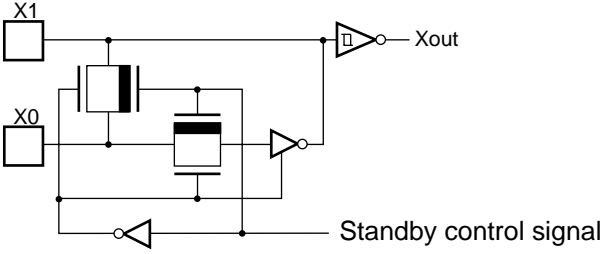
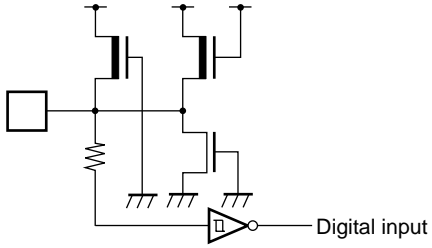
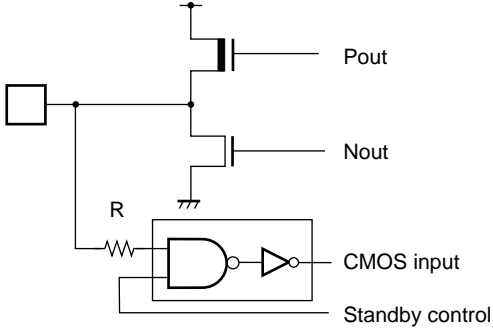
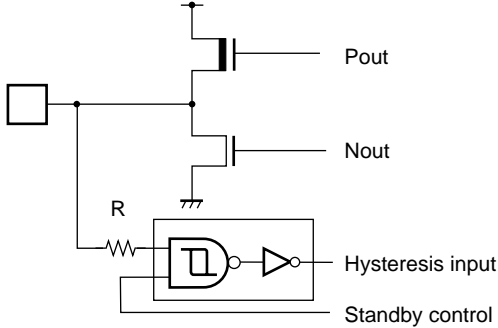
Type	Circuit	Remarks
A		<ul style="list-style-type: none"> High-speed oscillation circuit Oscillation feedback resistor = approx. 1 MΩ
B		<ul style="list-style-type: none"> CMOS hysteresis input pin CMOS hysteresis input (standby control not attached) Pullup resistor
C		<ul style="list-style-type: none"> CMOS level I/O pin CMOS level output CMOS level input (attached with standby control) <p>$I_{OL} = 4 \text{ mA}$</p>
F		<ul style="list-style-type: none"> CMOS hysteresis I/O pin CMOS level output CMOS hysteresis input (attached with standby control) <p>$I_{OL} = 4 \text{ mA}$</p>

(Continued)

MB91F158

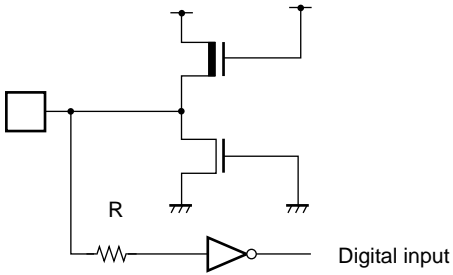
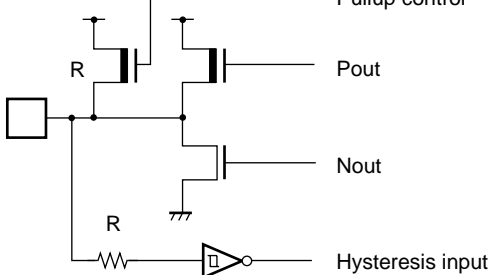
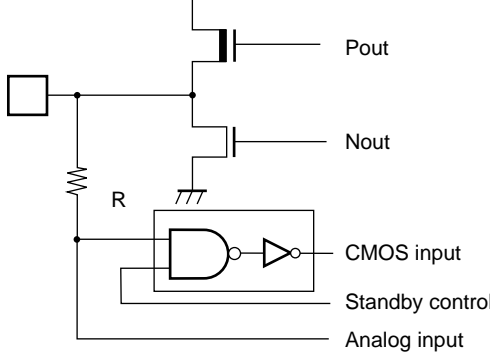
Type	Circuit	Remarks
G		<ul style="list-style-type: none"> • CMOS level input pin CMOS level input (standby control not attached)
H		<ul style="list-style-type: none"> • CMOS hysteresis I/O pin with pullup control CMOS level output CMOS level input (standby control not attached) Pullup resistance = approx. 50 kΩ (Typ) <p>$I_{OL} = 4 \text{ mA}$</p>
N		<ul style="list-style-type: none"> • Analog/CMOS level I/O pin. CMOS level output CMOS level input (attached with standby control) Analog input (Analog input is enabled when AIC's corresponding bit is set to "1.") <p>$I_{OL} = 4 \text{ mA}$</p>

(Continued)

(Continued)

Type	Circuit	Remarks
O		<ul style="list-style-type: none"> • CMOS hysteresis I/O pin with pullup control • CMOS level output • CMOS hysteresis input (attached with standby control) • Pullup resistance = approx. 50 kΩ (Typ) <p>$I_{OL} = 4 \text{ mA}$</p>
P		<ul style="list-style-type: none"> • CMOS hysteresis I/O pin with pullup control. • CMOS level output (attached with open drain control) • CMOS hysteresis input (attached with standby control) • Pullup resistance = approx. 50 kΩ (Typ) <p>$I_{OL} = 4 \text{ mA}$</p>

■ HANDLING DEVICES

1. Preventing Latchup

In CMOS ICs, applying voltage higher than V_{CC} or lower than V_{SS} to input/output pin or applying voltage over rating across V_{CC} and V_{SS} may cause latchup.

This phenomenon rapidly increases the power supply current, which may result in thermal breakdown of the device. Make sure to prevent the voltage from exceeding the maximum rating.

2. Treatment of Pins

• Treatment of unused pins

Unused pins left open may cause malfunctions. Make sure to connect them to pull-up or pull-down resistors.

• Treatment of open pins

Be sure to use open pins in open state.

• Treatment of output pins

Shortcircuiting an output pin with the power supply or with another output pin or connecting a large-capacity load may causes a flow of large current. If this conditions continues for a lengthy period of time, the device deteriorates. Take great care not to exceed the absolute maximum ratings.

• Mode pins (MD0-MD2)

These pins should be used directly connected to either V_{CC} or V_{SS} . In order to prevent noise from causing accidental entry into test mode, keep the pattern length as short as possible between each mode pin and V_{CC} or V_{SS} on the board and connect them with low impedance.

• Power supply pins

When there are several V_{CC} and V_{SS} pins, each of them is equipotentially connected to its counterpart inside of the device, minimizing the risk of malfunctions such as latch up. To further reduce the risk of malfunctions, to prevent EMI radiation, to prevent strobe signal malfunction resulting from creeping-up of ground level and to observe the total output current standard, connect all V_{CC} and V_{SS} pins to the power supply or GND.

It is preferred to connect V_{CC} and V_{SS} of MB91F158 to power supply with minimal impedance possible.

It is also recommended to connect a ceramic capacitor as a bypass capacitor of about 0.1 μF between V_{CC} and V_{SS} at a position as close as possible to MB91F158.

• Crystal oscillator circuit

Noises around X0 and X1 pins may cause malfunctions of MB91F158. In designing the PC board, layout X0, X1 and crystal oscillator (or ceramic oscillator) and bypass capacitor for grounding as close as possible.

It is strongly recommended to design PC board so that X0 and X1 pins are surrounded by grounding area for stable operation.

The MB91F158 device do not contain a feedback resistor. To use the clock function, you need to connect an external resistor.

3. Precautions

• External Reset Input

It takes at least 5 machine cycle to input "L" level to the $\overline{\text{RST}}$ pin and to ensure inner reset operation properly.

• External Clocks

When using an external clock, normally, a clock of which the phase is opposite to that of X0 must be supplied to the X0 and X1 pins simultaneously. However, when using the clock along with STOP (oscillation stopped) mode, the X1 pin stops when "H" is input in STOP mode. To prevent one output from competing against another, an external resistor of about 1 k Ω should be provided.

The following figure shows an example usage of an external clock.

Figure 3.1 An example usage of an external clock

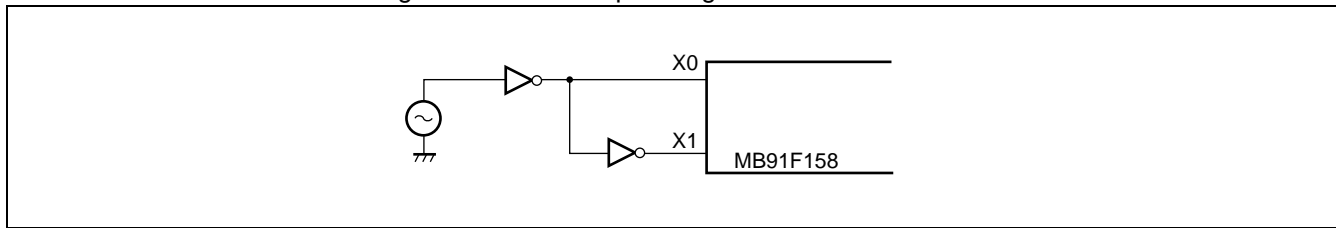

- **Care during operating of PLL clock mode**

If the PLL clock mode is selected, the microcontroller attempt to be working with the self-oscillating circuit even when there is no external oscillator or external clock input is stopped. Performance of this operation, however, cannot be guaranteed.

- **Watchdog timer function**

The watchdog timer supported by the FR family monitors the program that performs the reset delay operation for a specified time. If the program hangs and the reset delay operation is not performed, the watchdog timer resets the CPU. Therefore, once the watchdog timer is enabled, operation continues until the CPU is reset. As an exception, a reset delay automatically occurs if the CPU stops program execution. For the conditions that apply to this exception, refer to the section that describes the watchdog function.

4. Care During Powering Up

- **When powering up**

When turning on the power supply, never fail to start from setting the $\overline{\text{RST}}$ pin to "L" level. And after the power supply voltage goes to V_{CC} level, at least after ensuring the time for 5 machine cycle, then set to "H" level.

- **Source oscillation input**

At turning on the power supply, never fail to input the clock before cancellation of the oscillation stabilizing waiting.

- **Power on resetting**

When powering up or when turning the power back on after the supply voltage drops below the operation assurance range, be sure to reset the power.

- **Power on sequence**

Turn on the power in the order of V_{CC} , AV_{CC} and AV_{RH} . The power should be disconnected in inverse order.

- **Even when an A/D converter is not in use, connect AV_{CC} to the V_{CC} level and AV_{SS} to the V_{SS} level.**

- **Even when a D/A converter is not in use, connect DA_{VC} to the V_{CC} level and DA_{VS} to the V_{SS} level.**

MB91F158

■ BLOCK DIAGRAM

• MB91F158

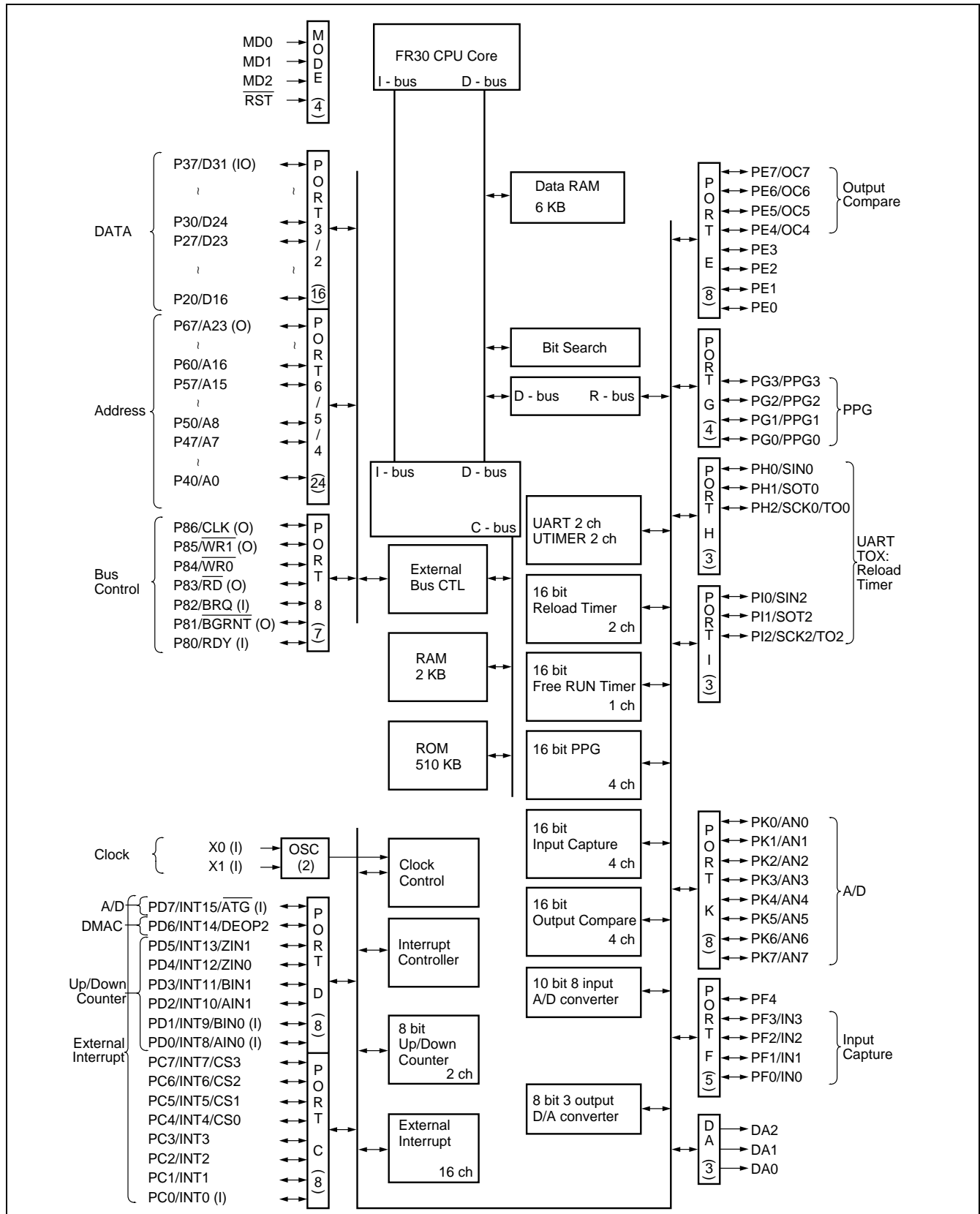

■ CPU CORE

1. Memory Space

The FR family has a logical address space of 4 Gbytes (2^{32} bytes) and the CPU linearly accesses the memory space.

- **Direct addressing area**

The following area in the address space is used for I/O.

This area is called direct addressing area and an operand address can be specified directly in an instruction.

The direct addressing area varies with the data size to be accessed as follows :

→ byte data access : 0-0FF_H

→ half word data access : 0-1FF_H

→ word data access : 0-3FF_H

2. Memory Map

- **Memory Space**

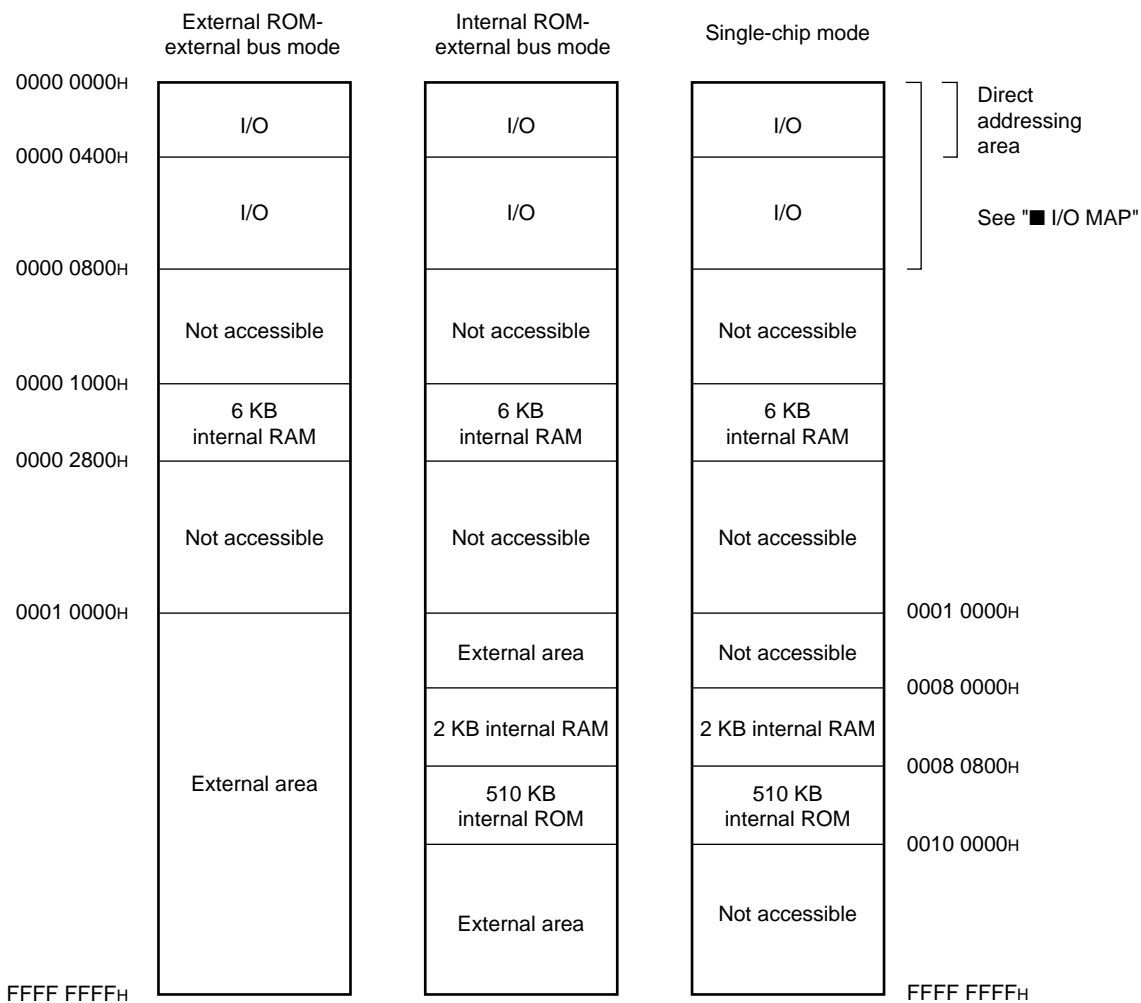

Note : External areas are not accessible in single-chip mode.

MB91F158

3. Registers

The family of FR microcontrollers has two types of registers : the registers residing in the CPU which are dedicated to applications and the general-purpose registers residing in the memory.

• Dedicated registers :

- Program counter (PC) : A 32-bit register to indicate the location where an instructions is stored.
- Program status (PS) : A 32-bit register to store a register pointer or a condition code.
- Tablebase register (TBR) : Holds the vector table lead address used when EIT (exceptions/interrupt/ trap) is processed.
- Return pointer (RP) : Holds the address to return from a subroutine to.
- System stack pointer (SSP) : Points to the system stack space.
- User stack pointer (USP) : Points to the user stack space.
- Multiplication and division result register (MDH/MDL) : A 32-bit multiplication and division register.

Register Name	Description	Initial value
PC	Program counter	XXXX XXXXH (Undefined)
PS	Program status	
TBR	Tablebase register	000F FC00H
RP	Return pointer	XXXX XXXXH (Undefined)
SSP	System stack pointer	0000 0000H
USP	User stack pointer	XXXX XXXXH (Undefined)
MDH	Multiplication and division register	XXXX XXXXH (Undefined)
MDL		XXXX XXXXH (Undefined)

• Program status (PS)

The PS register holds program status and is further divided into three registers which are a Condition Code Register (CCR) , a System condition Code Register (SCR) , and an Interrupt Level Mask register (ILM) .

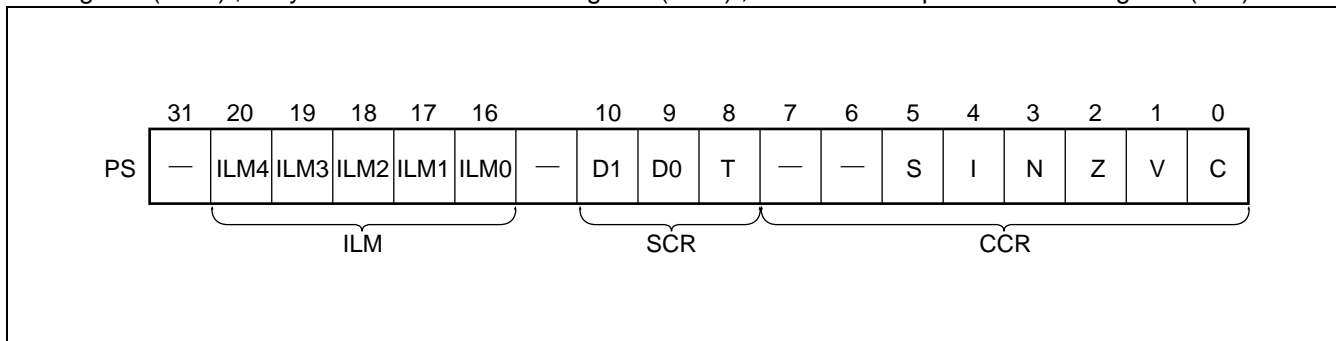

- **Condition Code Register (CCR)**

S flag : Designates the stack pointer for use as R15.

I flag : Controls enabling and disabling of user interrupt requests.

N flag : Indicates the sign when arithmetic operation results are considered to be an integer represented by 2's complement.

Z flag : Indicates if arithmetic results were "0."

V flag : Considers the operand used for an arithmetic operation to be an integer represented by 2's complement and indicates if the operation resulted in an overflow.

C flag : Indicates whether or not an arithmetic operation resulted in a carry or a borrow from the most significant bit.

- **System condition Code Register (SCR)**

T flag : Designates whether or not to enable step trace trap.

- **Interrupt Level Mask register (ILM)**

ILM4 to ILM0 : Holds an interrupt level mask value to be used for level masking.

An interrupt request is accepted only if the corresponding interrupt level among interrupt requests input to the CPU is higher than the value indicated by the ILM register.

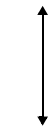
ILM4	ILM3	ILM2	ILM1	ILM0	Interrupt level	High-Low
0	0	0	0	0	0	Higher  Lower
					⋮	
0	1	0	0	0	15	
					⋮	
1	1	1	1	1	31	

■ GENERAL-PURPOSE REGISTERS

General-purpose registers are CPU registers R0 through R15 and used as accumulators during various operations and as memory access pointers (fields indicating addresses) .

• Register Bank Configuration

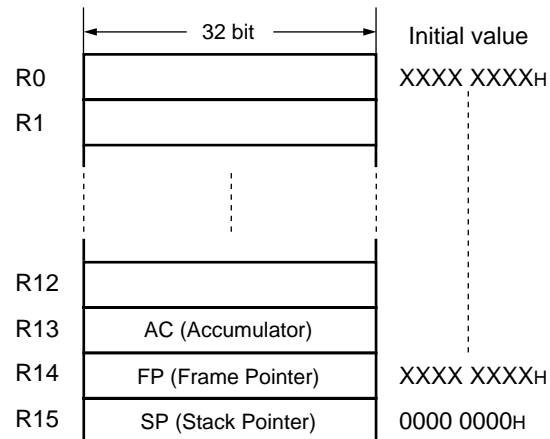

Of the 16 general-purpose registers, the following registers are assumed for specific applications. For this reason, some instructions are enhanced.

- R13 : Virtual accumulator (AC)
- R14 : Frame pointer (FP)
- R15 : Stack pointer (SP)

Initial values to which R0 through R14 are reset are not defined. The initial value of R15 is 0000 0000H (the SSP value) .

■ SETTING MODE

1. Mode Pins

As shown in Table 1 three pins, MD2, 1, and 0 are used to indicate an operation.

Table 1 Mode pins and set modes

Mode pin			Mode name	Reset vector access area	External data bus width	
MD2	MD1	MD0				
0	0	0	External vector mode 0	External	8 bits	External ROM bus mode
0	0	1	External vector mode 1	External	16 bits	
0	1	0	External vector mode 2	External	32 bits	Not available on this product type
0	1	1	External vector mode	Internal	(Mode register)	Single-chip mode
1	—	—	—	—	—	Not available

2. Mode Data

The data which the CPU writes to "0000 07FF_H" after reset is called mode data.

It is the mode register (MODR) that exists at "0000 07FF_H." Once a mode is set in this register, operations will take place in that mode. The mode register can be written only once after reset.

The mode specified in the register is enabled immediately after it is written.

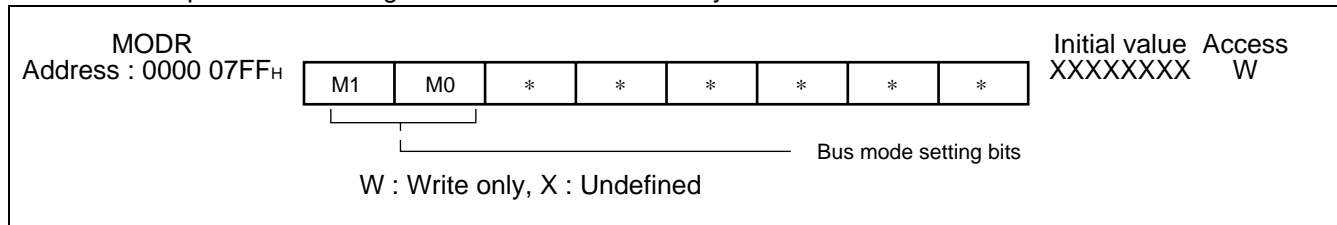

[bits 7 and 6] : M1, M0

These are bus mode setting bits. Specify the bus mode to be set to after writing to the mode register.

M1	M0	Function	Remarks
0	0	Single-chip mode	
0	1	Internal ROM-external bus mode	
1	0	External ROM-external bus mode	
1	1	—	Setting not allowed

[bits 5 to 0] : *

These bits are reserved for the system.

"0" should be written to these bits at all times.

MB91F158

[Precautions When Writing to the MODR]

Before writing to the MODR, be sure to set AMD0 through 5 and determine the bus width in each CS (Chip Select) area.

The MODR does not have bus width setting bits.

The bus width value set with mode pins MD2 through 0 is enabled before writing to the MODR and the bus width value set with BW1 and 0 of AMD0 through 5 is enabled after writing to the MODR.

For example, the external reset vector is normally executed with area 0 (the area where CS0 is active) and the bus width at that time is determined by pins MD 2 through 0. Suppose that the bus width is set to 32 or 16 bits in MD2 though 0 but no value is specified in AMD 0. If the MODR is written in this state, area 0 then switches to 8-bit bus mode and operates the bus since the initial bus width in AMD0 is set to 8 bits. This causes a malfunction.

In order to prevent this type of problem, AMD0 through 5 must always be set before writing to the MODR.



■ I/O MAP

Address	Register				Block
	+0	+1	+2	+3	
000000H	PDR3 (R/W) XXXXXXXX	PDR2 (R/W) XXXXXXXX	—		Port Data Register
000004H	—	PDR6 (R/W) XXXXXXXX	PDR5 (R/W) XXXXXXXX	PDR4 (R/W) XXXXXXXX	
000008H	—			PDR8 (R/W) - XXXXXXX	
00000CH	—				
000010H	PDRF (R/W) --- XXXXX	PDRE (R/W) XXXXXXXX	PDRD (R/W) XXXXXXXX	PDRC (R/W) XXXXXXXX	
000014H	—	PDR1 (R/W) ----- XXX	PDRH (R/W) ----- XXX	PDRG (R/W) ---- XXXX	
000018H	—		—	PDRK (R/W) XXXXXXXX	
00001CH	SSR0 (R, R/W) 00001000	SIDR0/SODR0 (R, W) XXXXXXXX	SCR0 (R/W, W) 00000100	SMR0 (R/W) 00000 - 00	UART0
000020H	—				Reserved
000024H	SSR2 (R, R/W) 00001000	SIDR2/SODR2 (R, W) XXXXXXXX	SCR2 (R/W, W) 00000100	SMR2 (R/W) 00000 - 00	UART2
000028H	—				Reserved
00002CH	TMRLR0 (W) XXXXXXXX XXXXXXXX		TMR0 (R) XXXXXXXX XXXXXXXX		Reload Timer 0
000030H	—		TMCSR0 (R/W) ---- 0000 00000000		
000034H to 000038H	—				Reserved
00003CH	TMRLR2 (W) XXXXXXXX XXXXXXXX		TMR2 (R) XXXXXXXX XXXXXXXX		Reload Timer 2
000040H	—		TMCSR2 (R/W) ---- 0000 00000000		
000044H to 000048H	—				Reserved
00004CH	—	—	CDCR0 (R/W) 0 --- 0000	—	Communications prescaler 1
000050H	—	—	CDCR2 (R/W) 0 --- 0000	—	
000054H to 000058H	—				Reserved

(Continued)

MB91F158

Address	Register				Block
	+0	+1	+2	+3	
00005CH	RCR1 (W) 00000000	RCR0 (W) 00000000	UDCR1 (R) 00000000	UDCR0 (R) 00000000	8/16 bit U/D Counter
000060H	CCR0 (R/W) 00000000	CCRL0 (R/W, W) - 000X000	—	CSR0 (R/W, R) 00000000	
000064H	CCR1 (R/W) - 0000000	CCRL1 (R/W, W) - 000X000	—	CSR1 (R/W, R) 00000000	
000068H	IPCP1 (R) XXXXXXXX XXXXXXXX		IPCP0 (R) XXXXXXXX XXXXXXXX		16 bit ICU
00006CH	IPCP3 (R) XXXXXXXX XXXXXXXX		IPCP2 (R) XXXXXXXX XXXXXXXX		
000070H	—	ICS23 (R/W) 00000000	—	ICS01 (R/W) 00000000	
000074H to 000078H	—				Reserved
00007CH	OCCP5 (R/W) XXXXXXXX XXXXXXXX		OCCP4 (R/W) XXXXXXXX XXXXXXXX		16 bit OCU
000080H	OCCP7 (R/W) XXXXXXXX XXXXXXXX		OCCP6 (R/W) XXXXXXXX XXXXXXXX		
000084H	—				Reserved
000088H	OCS6, 7 (R/W) XXX00000 0000XX00		OCS4, 5 (R/W) XXX00000 0000XX00		16 bit OCU
00008CH	TCDT (R/W) 00000000 00000000		TCCS (R/W) 0 - - - - - 00000000		16 bit Freerun Timer
000090H	STPR0 (R/W) 0 - 0 - - - - -	STPR1 (R/W) 0 - 0 - 0 - 00	STPR2 (R/W) 0000 - - - -	—	Stop Register 0, 1, 2
000094H	GCN1 (R/W) 00110010 00010000		—	GCN2 (R/W) 00000000	PPG controler
000098H	PTMR0 (R) 11111111 11111111		PCSR0 (W) XXXXXXXX XXXXXXXX		PPG0
00009CH	PDUT0 (W) XXXXXXXX XXXXXXXX		PCNH0 (R/W) 0000000 -	PCNL0 (R/W) 00000000	
0000A0H	PTMR1 (R) 11111111 11111111		PCSR1 (W) XXXXXXXX XXXXXXXX		PPG1
0000A4H	PDUT1 (W) XXXXXXXX XXXXXXXX		PCNH1 (R/W) 0000000 -	PCNL1 (R/W) 00000000	
0000A8H	PTMR2 (R) 11111111 11111111		PCSR2 (W) XXXXXXXX XXXXXXXX		PPG2
0000ACH	PDUT2 (W) XXXXXXXX XXXXXXXX		PCNH2 (R/W) 0000000 -	PCNL2 (R/W) 00000000	
0000B0H	PTMR3 (R) 11111111 11111111		PCSR3 (W) XXXXXXXX XXXXXXXX		PPG3
0000B4H	PDUT3 (W) XXXXXXXX XXXXXXXX		PCNH3 (R/W) 0000000 -	PCNL3 (R/W) 00000000	

(Continued)

Address	Register				Block
	+0	+1	+2	+3	
0000B8H to 0000C4H	—				Reserved
0000C8H	EIRRO (R/W) 00000000	ENIRO (R/W) 00000000	EIRR1 (R/W) 00000000	ENIR1 (R/W) 00000000	Ext int
0000CCH	ELVR0 (R/W) 00000000 00000000		ELVR1 (R/W) 00000000 00000000		
0000D0H to 0000D8H	—				Reserved
0000DC _H	—	DACR2 (R/W) ----- 0	DACR1 (R/W) ----- 0	DACR0 (R/W) ----- 0	D/A Converter
0000E0 _H	—	DADR2 (R/W) XXXXXXXX	DADR1 (R/W) XXXXXXXX	DADR0 (R/W) XXXXXXXX	
0000E4 _H	ADCR (R, W) 00101- XX XXXXXXXX		ADCS1 (R/W, W) 00000000	ADCS0 (R/W) 00000000	A/D Converter (Sequential type)
0000E8 _H	—			AICK (R/W) 00000000	Analog Input Control
0000EC _H to 0000F0 _H	—				Reserved
0000F4 _H	PCRI (R/W) ----- 000	PCRH (R/W) ----- 000	PCRD (R/W) 00000000	PCRC (R/W) 00000000	Pull Up Control
0000F8 _H	OCRI (R/W) ----- 000	OCRH (R/W) ----- 000	—		Opendrain Control
0000FC _H	DDRF (R/W) --- 00000	DDRE (R/W) 00000000	DDRD (R/W) 00000000	DDRC (R/W) 00000000	Data Direction Register
000100 _H	—	DDRI (R/W) - 0 --- 000	DDRH (R/W) ----- 000	DDRG (R/W) ---- 0000	
000104 _H	—			DDRK (R/W) 00000000	
000108 _H to 0003EC _H	—				Reserved
0003F0 _H	BSD0 (W) XXXXXXXX XXXXXXXX XXXXXXXX XXXXXXXX				Bit Search Module
0003E4 _H	BSD1 (R/W) XXXXXXXX XXXXXXXX XXXXXXXX XXXXXXXX				
0003F8 _H	BSDC (W) XXXXXXXX XXXXXXXX XXXXXXXX XXXXXXXX				
0003FC _H	BSRR (R) XXXXXXXX XXXXXXXX XXXXXXXX XXXXXXXX				

(Continued)

MB91F158

Address	Register				Block
	+0	+1	+2	+3	
000400 _H	ICR00 (R/W) ---- 1111	ICR01 (R/W) ---- 1111	ICR02 (R/W) ---- 1111	ICR03 (R/W) ---- 1111	Interrupt Control Unit
000404 _H	ICR04 (R/W) ---- 1111	ICR05 (R/W) ---- 1111	ICR06 (R/W) ---- 1111	ICR07 (R/W) ---- 1111	
000408 _H	ICR08 (R/W) ---- 1111	—	ICR10 (R/W) ---- 1111	—	
00040C _H	ICR012 (R/W) ---- 1111	—	—	ICR15 (R/W) ---- 1111	
000410 _H	—	ICR17 (R/W) ---- 1111	—	—	
000414 _H	—	ICR21 (R/W) ---- 1111	—	ICR23 (R/W) ---- 1111	
000418 _H	—	—	ICR26 (R/W) ---- 1111	ICR27 (R/W) ---- 1111	
00041C _H	ICR28 (R/W) ---- 1111	ICR29 (R/W) ---- 1111	ICR30 (R/W) ---- 1111	—	
000420 _H	—	ICR33 (R/W) ---- 1111	ICR34 (R/W) ---- 1111	ICR35 (R/W) ---- 1111	
000424 _H	ICR36 (R/W) ---- 1111	ICR37 (R/W) ---- 1111	ICR38 (R/W) ---- 1111	—	
000428 _H	—	—	—	ICR43 (R/W) ---- 1111	
00042C _H	ICR44 (R/W) ---- 1111	—	ICR46 (R/W) ---- 1111	ICR47 (R/W) ---- 1111	
000430 _H	DICR (R/W) ----- 0	HRCL (R/W) ---- 1111	—		
000434 _H to 00047C _H	—				Reserved
000480 _H	RSRR/WTCR (R, W) 1-XXX-00	STCR (R/W, W) 000111--	PDRR (R/W) ---- 0000	CTBR (W) XXXXXXXX	Clock Control unit
000484 _H	GCR (R/W, R) 110011-1	WPR (W) XXXXXXXX	—		
000488 _H	PTCR (R/W) 00XX0XXX	—			PLL Control
00048C _H to 0005FC _H	—				Reserved
000600 _H	DDR3 (W) 00000000	DDR2 (W) 00000000	—	—	Data Direction Register
000604 _H	—	DDR6 (W) 00000000	DDR5 (W) 00000000	DDR4 (W) 00000000	
000608 _H	—			DDR8 (W) - 0000000	

(Continued)

(Continued)

Address	Register				Block
	+0	+1	+2	+3	
00060C _H	ASR1 (W) 00000000 00000001		AMR1 (W) 00000000 00000000		External bus interface
000610 _H	ASR2 (W) 00000000 00000010		AMR2 (W) 00000000 00000000		
000614 _H	ASR3 (W) 00000000 00000011		AMR3 (W) 00000000 00000000		
000618 _H	ASR4 (W) 00000000 00000100		AMR4 (W) 00000000 00000000		
00061C _H	ASR5 (W) 00000000 00000101		AMR5 (W) 00000000 00000000		
000620 _H	AMD0 (R/W) --- 00111	AMD1 (R/W) 0 -- 00000	AMD32 (R/W) 00000000	AMD4 (R/W) 0 -- 00000	
000624 _H	AMD5 (R/W) 0 -- 00000	—			
000628 _H	EPCR0 (W) ---- 1100 -1111111		EPCR1 (W) ----- 11111111		
00062C _H	—				Reserved
000630 _H	—	PCR6 (R/W) 00000000	—		Pull Up Control
000634 _H to 0007BC _H	—				Reserved
0007C0 _H	FLCR (R/W, R) 000XXXX0	—			FLASH Control
0007C4 _H	FWTC (R/W, W) 10010100	—			
0007C8 _H to 0007F8 _H	—				Reserved
0007FC _H	—		LER (W) ----- 000	MODR (W) XXXXXXXXX	Little Endian Register Mode Register

Note : Do not execute RMW instructions on registers having a write-only bit.

RMW instructions (RMW : Read Modify Write)

AND Rj, @Ri	OR Rj, @Ri	EOR Rj, @Ri
ANDH Rj, @Ri	ORH Rj, @Ri	EORH Rj, @Ri
ANDB Rj, @Ri	ORB Rj, @Ri	EORB Rj, @Ri
BANDL #u4, @Ri	BORL #u4, @Ri	BEORL #u4, @Ri
BANDH #u4, @Ri	BORH #u4, @Ri	BEORH #u4, @Ri

Data is undefined in "Reserved" or (—) areas.

() : Access
 R/W : Read/Write enabled
 R : Read only
 W : Write only
 — : Not in use
 X : Undefined

■ INTERRUPT FACTORS AND ASSIGNMENT OF INTERRUPT VECTORS AND RESISTERS

Factor	Interrupt No.		Interrupt level	Offset	Default TBR address
	Decimal	Hex.			
Reset	0	00	—	3FC _H	000FFFFC _H
Reserved for the system	1	01	—	3F8 _H	000FFFF8 _H
Reserved for the system	2	02	—	3F4 _H	000FFFF4 _H
Reserved for the system	3	03	—	3F0 _H	000FFFF0 _H
Reserved for the system	4	04	—	3EC _H	000FFFE _C
Reserved for the system	5	05	—	3E8 _H	000FFFE8 _H
Reserved for the system	6	06	—	3E4 _H	000FFFE4 _H
Reserved for the system	7	07	—	3E0 _H	000FFFE0 _H
Reserved for the system	8	08	—	3DC _H	000FFFD _C
Reserved for the system	9	09	—	3D8 _H	000FFFD8 _H
Reserved for the system	10	0A	—	3D4 _H	000FFFD4 _H
Reserved for the system	11	0B	—	3D0 _H	000FFFD0 _H
Reserved for the system	12	0C	—	3CC _H	000FFF _{CC}
Reserved for the system	13	0D	—	3C8 _H	000FFF _{C8}
Undefined instruction exception	14	0E	—	3C4 _H	000FFF _{C4}
Reserved for the system	15	0F	—	3C0 _H	000FFF _{C0}
External interrupt 0	16	10	ICR00	3BC _H	000FFF _{BC}
External interrupt 1	17	11	ICR01	3B8 _H	000FFF _{B8}
External interrupt 2	18	12	ICR02	3B4 _H	000FFF _{B4}
External interrupt 3	19	13	ICR03	3B0 _H	000FFF _{B0}
External interrupt 4	20	14	ICR04	3AC _H	000FFF _{AC}
External interrupt 5	21	15	ICR05	3A8 _H	000FFF _{A8}
External interrupt 6	22	16	ICR06	3A4 _H	000FFF _{A4}
External interrupt 7	23	17	ICR07	3A0 _H	000FFF _{A0}
External interrupts 8 - 15	24	18	ICR08	39C _H	000FFF _{9C}
Reserved for the system	25	19	—	398 _H	000FFF ₉₈
UART0 (receiving complete)	26	1A	ICR10	394 _H	000FFF ₉₄
Reserved for the system	27	1B	ICR11	390 _H	000FFF ₉₀
UART2 (receiving complete)	28	1C	ICR12	38C _H	000FFF _{8C}
Reserved for the system	29	1D	ICR13	388 _H	000FFF ₈₈
Reserved for the system	30	1E	—	384 _H	000FFF ₈₄
UART0 (sending complete)	31	1F	ICR15	380 _H	000FFF ₈₀
Reserved for the system	32	20	ICR16	37C _H	000FFF _{7C}
UART2 (sending complete)	33	21	ICR17	378 _H	000FFF ₇₈

(Continued)

Factor	Interrupt No.		Interrupt level	Offset	Default TBR address
	Decimal	Hex.			
Reserved for the system	34	22	ICR18	374 _H	000FFF74 _H
Reserved for the system	35	23	ICR19	370 _H	000FFF70 _H
Reserved for the system	36	24	ICR20	36C _H	000FFF6C _H
Reload timer 0	37	25	ICR21	368 _H	000FFF68 _H
Reserved for the system	38	26	ICR22	364 _H	000FFF64 _H
Reload timer 2	39	27	ICR23	360 _H	000FFF60 _H
Reserved for the system	40	28	ICR24	35C _H	000FFF5C _H
A/D (sequential type)	42	2A	ICR26	354 _H	000FFF54 _H
PPG0	43	2B	ICR27	350 _H	000FFF50 _H
PPG1	44	2C	ICR28	34C _H	000FFF4C _H
PPG2	45	2D	ICR29	348 _H	000FFF48 _H
PPG3	46	2E	ICR30	344 _H	000FFF44 _H
Reserved for the system	47	2F	ICR31	340 _H	000FFF40 _H
Reserved for the system	48	30	ICR32	33C _H	000FFF3C _H
U/Dcounter 0 (compare/underflow, overflow, up-down inversion)	49	31	ICR33	338 _H	000FFF38 _H
U/Dcounter 1 (compare/underflow, overflow, up-down inversion)	50	32	ICR34	334 _H	000FFF34 _H
ICU0 (Read)	51	33	ICR35	330 _H	000FFF30 _H
ICU1 (Read)	52	34	ICR36	32C _H	000FFF2C _H
ICU2 (Read)	53	35	ICR37	328 _H	000FFF28 _H
ICU3 (Read)	54	36	ICR38	324 _H	000FFF24 _H
Reserved for the system	55	37	ICR39	320 _H	000FFF20 _H
Reserved for the system	56	38	ICR40	31C _H	000FFF1C _H
Reserved for the system	57	39	ICR41	318 _H	000FFF18 _H
Reserved for the system	58	3A	ICR42	314 _H	000FFF14
OCU4/5 (Match)	59	3B	ICR43	310 _H	000FFF10 _H
OCU6/7 (Match)	60	3C	ICR44	30C _H	000FFF0C _H
Reserved for the system	61	3D	—	308 _H	000FFF08 _H
16-bit free-run timer	62	3E	ICR46	304 _H	000FFF04 _H
Delay interrupt factor bit	63	3F	ICR47	300 _H	000FFF00 _H

(Continued)

MB91F158

(Continued)

Factor	Interrupt No.		Interrupt level	Offset	Default TBR address
	Decimal	Hex.			
Reserved for the system (used by REALOS*)	64	40	—	2FC _H	000FFEFC _H
Reserved for the system (used by REALOS*)	65	41	—	2F8 _H	000FFE8 _H
Reserved for the system	66	42	—	2F4 _H	000FFE4 _H
Reserved for the system	67	43	—	2F0 _H	000FEF0 _H
Reserved for the system	68	44	—	2EC _H	000FEEC _H
Reserved for the system	69	45	—	2E8 _H	000FEE8 _H
Reserved for the system	70	46	—	2E4 _H	000FEE4 _H
Reserved for the system	71	47	—	2E0 _H	000FEE0 _H
Reserved for the system	72	48	—	2DC _H	000FEDC _H
Reserved for the system	73	49	—	2D8 _H	000FED8 _H
Reserved for the system	74	4A	—	2D4 _H	000FED4 _H
Reserved for the system	75	4B	—	2D0 _H	000FED0 _H
Reserved for the system	76	4C	—	2CC _H	000FECC _H
Reserved for the system	77	4D	—	2C8 _H	000FEC8 _H
Reserved for the system	78	4E	—	2C4 _H	000FEC4 _H
Reserved for the system	79	4F	—	2C0 _H	000FEC0 _H
Used with the INT instruction	80 to 255	50 to FF	—	2BC _H to 000 _H	000FEBC _H to 000FFC00 _H

* : REALOS/FR uses 0X40 and 0X41 interrupts for system codes.

■ PERIPHERAL RESOURCES

1. I/O Port

(1) Port Block Diagram

This LSI is available as an I/O port when the resource associated with each pin is set not to use a pin for input/output.

The pin level is read from the port (PDR) when it is set for input. When the port is set for output, the value in the data register is read. The same also applies to reload by read modify write.

When switching from input to output, output data is set in the data register beforehand. However, if a read modify write instruction (such as bit set) is used at that time, keep in mind that it is the input data from the pin that is read, not the latch value of the data register.

• Basic I/O Port

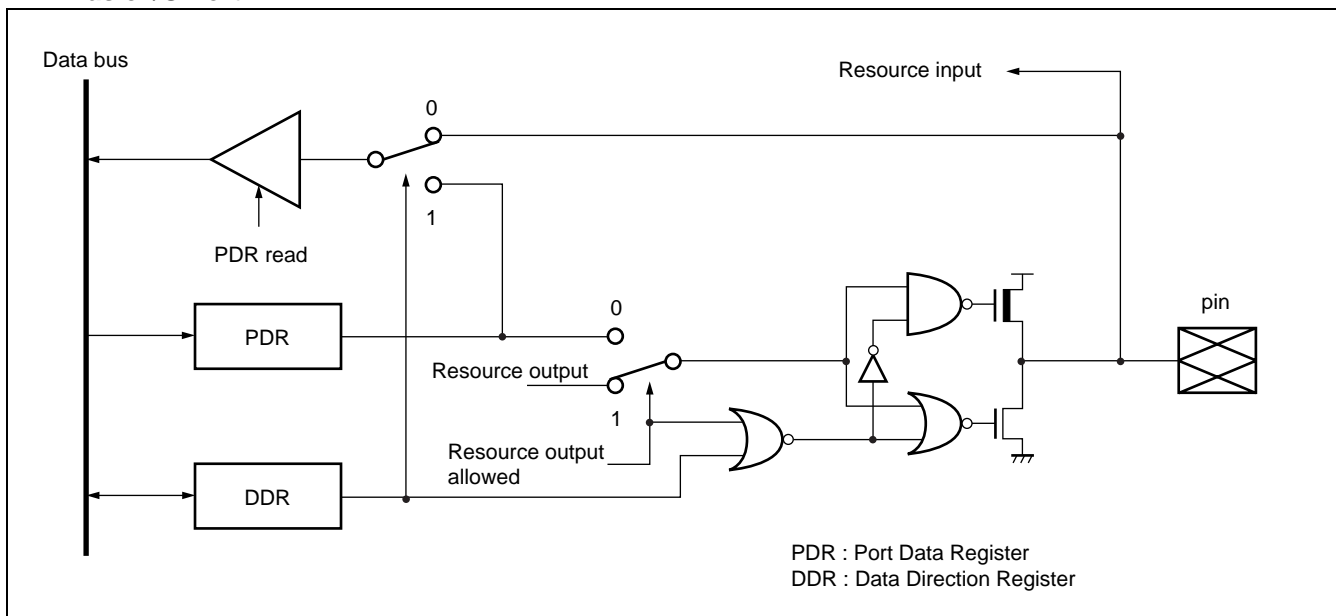

Figure PORT-1 Basic port block

The I/O port consists of the PDR (Port Data Register) and the DDR (Data Direction Register) .

In input mode (DDR = "0") → PDR read : Reads the level of the corresponding external pin.

PDR write : Writes the set value to the PDR.

In output mode (DDR = "1") → PDR read : Reads the PDR value.

PDR write : Outputs the PDR value to the corresponding external pin.

Note : AIC controls switching between the resource and port of the analog pin (A/D) .

AICK (Analog Input Control register on port-K)

The register controls whether port K should be used for analog input or as a general-purpose port.

0 : General-purpose port

1 : Analog input (A/D)

• I/O Port (attached with a pullup resistor)

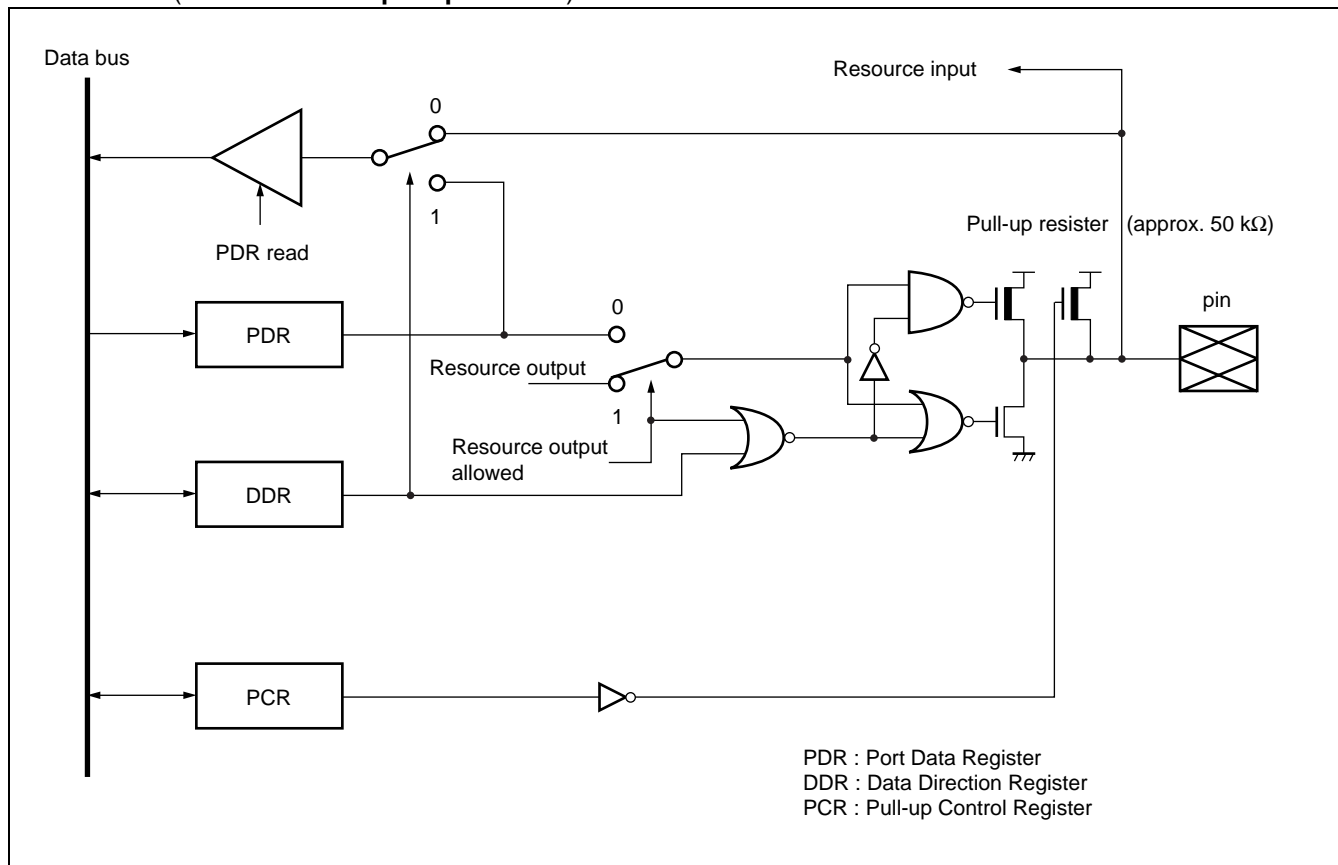

Figure PORT-2 Port block attached with a pullup resistor

Notes : • Pullup resistor control register (PCR) R/W
Controls turning the pullup resistor on/off.

0 : Pullup resistor disabled

1 : Pullup resistor enabled

• In stop mode priority is also given to the setting of the pullup resistor control register.

• This function is not available when a relevant pin is in use as an external bus pin. Do not write "1" to this register.

• I/O Port (attached with the open drain output function and a pullup resistor)

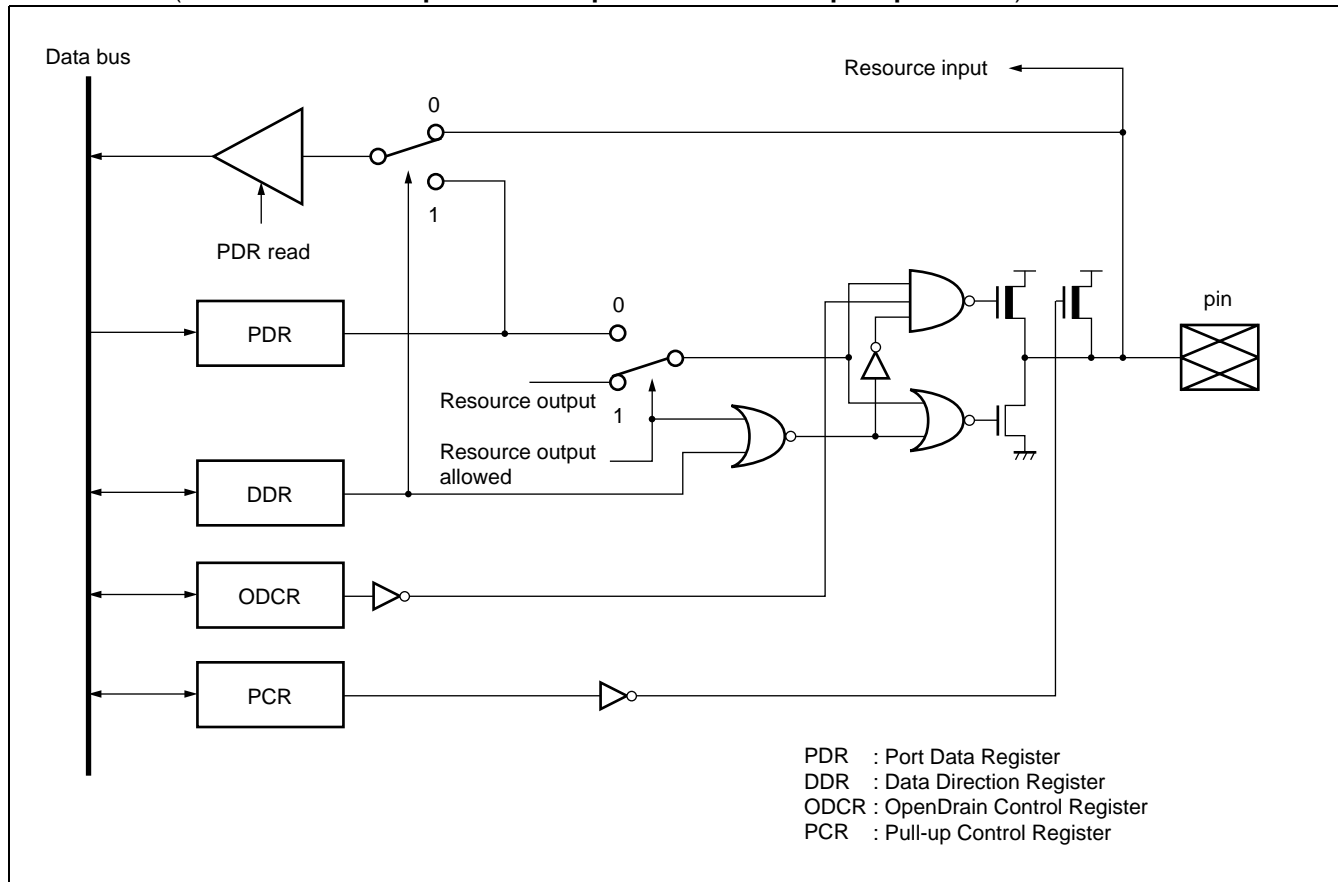

Figure PORT-3 Port block attached with the open drain output function and a pullup resistor

- Notes :
- Pullup resistor setup register (PCR) R/W
Controls turning the pullup resistor on/off.
0 : Pullup resistor disabled
1 : Pullup resistor enabled
 - Open drain control register (ODCR) R/W
Controls open drain in output mode.
0 : Standard output port during output mode
1 : Open-drain output port during output mode
This register has no significance in input mode (output Hi-Z) . Input/output mode is determined by the direction register (DDR) .
 - Priority is also given to the setting of the pullup resistor control register in stop mode.
 - When a relevant pin is used as an external bus pin, neither function is available. Do not write "1" to either register.

MB91F158

(2) Register Descriptions

• Port Data Register (PDR)

PDR2	7	6	5	4	3	2	1	0	Initial value	Access
Address : 000001H	P27	P26	P25	P24	P23	P22	P21	P20	XXXXXXXX _B	R/W
PDR3	7	6	5	4	3	2	1	0	Initial value	Access
Address : 000000H	P37	P36	P35	P34	P33	P32	P31	P30	XXXXXXXX _B	R/W
PDR4	7	6	5	4	3	2	1	0	Initial value	Access
Address : 000007H	P47	P46	P45	P44	P43	P42	P41	P40	XXXXXXXX _B	R/W
PDR5	7	6	5	4	3	2	1	0	Initial value	Access
Address : 000006H	P57	P56	P55	P54	P53	P52	P51	P50	XXXXXXXX _B	R/W
PDR6	7	6	5	4	3	2	1	0	Initial value	Access
Address : 000005H	P67	P66	P65	P64	P63	P62	P61	P60	XXXXXXXX _B	R/W
PDR8	7	6	5	4	3	2	1	0	Initial value	Access
Address : 00000BH	—	P86	P85	P84	P83	P82	P81	P80	- XXXXXXX _B	R/W
PDRC	7	6	5	4	3	2	1	0	Initial value	Access
Address : 000013H	PC7	PC6	PC5	PC4	PC3	PC2	PC1	PC0	XXXXXXXX _B	R/W
PDRD	7	6	5	4	3	2	1	0	Initial value	Access
Address : 000012H	PD7	PD6	PD5	PD4	PD3	PD2	PD1	PD0	XXXXXXXX _B	R/W
PDRE	7	6	5	4	3	2	1	0	Initial value	Access
Address : 000011H	PE7	PE6	PE5	PE4	PE3	PE2	PE1	PE0	XXXXXXXX _B	R/W
PDRF	7	6	5	4	3	2	1	0	Initial value	Access
Address : 000010H	—	—	—	PF4	PF3	PF2	PF1	PF0	--- XXXXX _B	R/W
PDRG	7	6	5	4	3	2	1	0	Initial value	Access
Address : 000017H	—	—	—	—	PG3	PG2	PG1	PG0	---- XXXX _B	R/W
PDRH	7	6	5	4	3	2	1	0	Initial value	Access
Address : 000016H	—	—	—	—	—	PH2	PH1	PH0	----- XXX _B	R/W
PDRI	7	6	5	4	3	2	1	0	Initial value	Access
Address : 000015H	—	—	—	—	—	PI2	PI1	PI0	----- XXX _B	R/W
PDRK	7	6	5	4	3	2	1	0	Initial value	Access
Address : 00001BH	PK7	PK6	PK5	PK4	PK3	PK2	PK1	PK0	XXXXXXXX _B	R/W

PDR2 to PDRK are the I/O data registers of the I/O port.
 Input/output is controlled with corresponding DDR2 to DDRK.
 R/W : Read/Write enabled, X : Undefined, — : Not in use

• Data Direction Register (DDR)

DDR2	7	6	5	4	3	2	1	0	Initial value	Access
Address : 000601 _H	P27	P26	P25	P24	P23	P22	P21	P20	0000000 _B	W
DDR3	7	6	5	4	3	2	1	0	Initial value	Access
Address : 000600 _H	P37	P36	P35	P34	P33	P32	P31	P30	0000000 _B	W
DDR4	7	6	5	4	3	2	1	0	Initial value	Access
Address : 000607 _H	P47	P46	P45	P44	P43	P42	P41	P40	0000000 _B	W
DDR5	7	6	5	4	3	2	1	0	Initial value	Access
Address : 000606 _H	P57	P56	P55	P54	P53	P52	P51	P50	0000000 _B	W
DDR6	7	6	5	4	3	2	1	0	Initial value	Access
Address : 000605 _H	P67	P66	P65	P64	P63	P62	P61	P60	0000000 _B	W
DDR8	7	6	5	4	3	2	1	0	Initial value	Access
Address : 00060B _H	—	P86	P85	P84	P83	P82	P81	P80	- 000000 _B	W
DDRC	7	6	5	4	3	2	1	0	Initial value	Access
Address : 0000FF _H	PC7	PC6	PC5	PC4	PC3	PC2	PC1	PC0	0000000 _B	R/W
DDR D	7	6	5	4	3	2	1	0	Initial value	Access
Address : 0000FE _H	PD7	PD6	PD5	PD4	PD3	PD2	PD1	PD0	0000000 _B	R/W
DDRE	7	6	5	4	3	2	1	0	Initial value	Access
Address : 0000FD _H	PE7	PE6	PE5	PE4	PE3	PE2	PE1	PE0	0000000 _B	R/W
DDRF	7	6	5	4	3	2	1	0	Initial value	Access
Address : 0000FC _H	—	—	—	PF4	PF3	PF2	PF1	PF0	--- 0000 _B	R/W
DDRG	7	6	5	4	3	2	1	0	Initial value	Access
Address : 000103 _H	—	—	—	—	PG3	PG2	PG1	PG0	---- 0000 _B	R/W
DDRH	7	6	5	4	3	2	1	0	Initial value	Access
Address : 000102 _H	—	—	—	—	—	PH2	PH1	PH0	----- 000 _B	R/W
DDRI	7	6	5	4	3	2	1	0	Initial value	Access
Address : 000101 _H	—	TEST	—	—	—	PI2	PI1	PI0	- 0 --- 000 _B	R/W
DDRK	7	6	5	4	3	2	1	0	Initial value	Access
Address : 000107 _H	PK7	PK6	PK5	PK4	PK3	PK2	PK1	PK0	0000000 _B	R/W

DDR2 to DDRK control the I/O direction of the I/O port by bit.

DDR = 0 : Port input

DDR = 1 : Port output

Note : DDRI's bit 6 is a test bit. Be sure to write "0" to the bit.

"0" is the value that is read.

R/W : Read/Write enabled, W : Write only, — : Not in use

• Pull-up Control Register (PCR)

PCR6		7	6	5	4	3	2	1	0	Initial value	Access
Address : 000631 _H		P67	P66	P65	P64	P63	P62	P61	P60	00000000 _B	R/W

PCRC		7	6	5	4	3	2	1	0	Initial value	Access
Address : 0000F7 _H		PC7	PC6	PC5	PC4	PC3	PC2	PC1	PC0	00000000 _B	R/W

PCRD		7	6	5	4	3	2	1	0	Initial value	Access
Address : 0000F6 _H		PD7	PD6	PD5	PD4	PD3	PD2	PD1	PD0	00000000 _B	R/W

PCRH		7	6	5	4	3	2	1	0	Initial value	Access
Address : 0000F5 _H		—	—	—	—	—	PH2	PH1	PH0	-----000 _B	R/W

PCRI		7	6	5	4	3	2	1	0	Initial value	Access
Address : 0000F4 _H		—	—	—	—	—	PI2	PI1	PI0	-----000 _B	R/W

PCR6 to PCRI control the pullup resistor when the corresponding I/O port is in input mode.

PCR = 0 : Pullup resistor not available in input mode

PCR = 1 : Pullup resistor available in input mode

The register has no significance in output mode (a pullup resistor not available) .

• Open Drain Control Register (ODCR)

OCRH		7	6	5	4	3	2	1	0	Initial value	Access
Address : 0000F9 _H		—	—	—	—	—	PH2	PH1	PH0	-----000 _B	R/W

OCRI		7	6	5	4	3	2	1	0	Initial value	Access
Address : 0000F8 _H		—	—	—	—	—	PI2	PI1	PI0	-----000 _B	R/W

OCRH and OCRI control open drain when the corresponding I/O port is in output mode.

OCR = 0 : Standard output port during output mode

OCR = 1 : Open drain output port during output mode

The register has no significance in input mode (output Hi-Z) .

• Analog Input Control Register (AICR)

AICK		7	6	5	4	3	2	1	0	Initial value	Access
Address : 0000EB _H		PK7	PK6	PK5	PK4	PK3	PK2	PK1	PK0	00000000 _B	R/W

The AICK controls each pin of a corresponding I/O port as follows :

AIC = 0 : Port input mode

AIC = 1 : Analog input mode

The register is reset to "0."

R/W : Read/Write enabled, — : Not in use

2. UART

The UART is a serial I/O port for asynchronous (start and stop synchronization) communication or CLK synchronous communication. This product type contains this UART for two channels. Its features are as follows :

- Full-duplex double buffer
- Capable of asynchronous (start and stop synchronization) and CLK synchronous communication.
- Support for multiprocessor mode
- Baud rate by a dedicated baud rate generator
- Baud rate by an internal timer

The baud rate can be set with a 16-bit reload timer.

- Any baud rate can be set using an external clock.
- Error detection function (parity, framing, and overrun)
- NRZ-encoded transfer signals

MB91F158

• Block Diagram

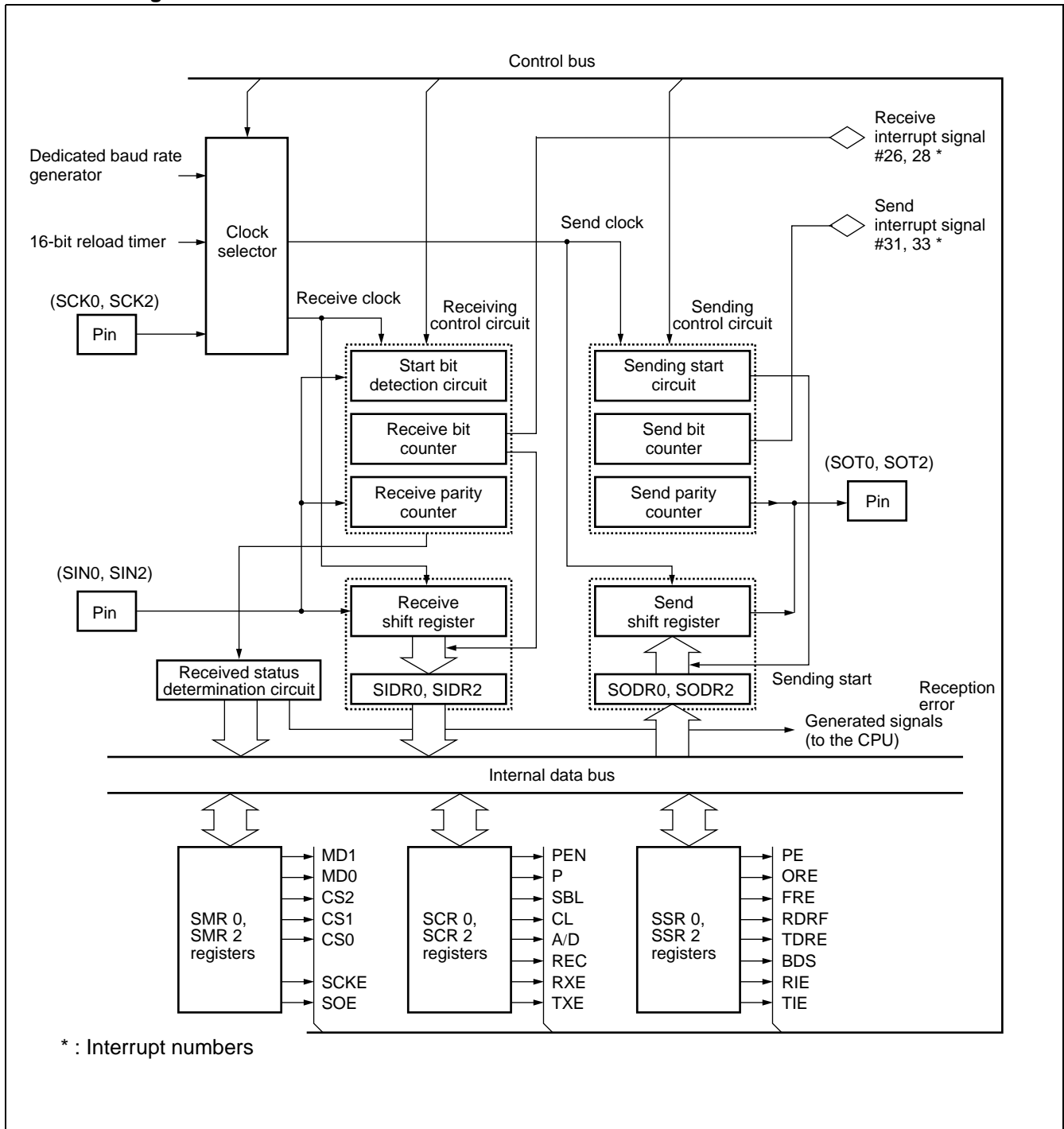

• Register List

Address	bit 15	bit 8	bit 0	Initial value
0000001EH	SCR0			00000100 _B (R/W,W)
00000026H	SCR2			00000100 _B (R/W,W)
0000001FH		SMR0		00000 - 00 _B (R/W)
00000027H		SMR2		00000 - 00 _B (R/W)
0000001CH	SSR0			00001000 _B (R, R/W)
00000024H	SSR2			00001000 _B (R, R/W)
0000001DH		SIDR0/SODR0		XXXXXXXX (R, W)
00000025H		SIDR2/SODR2		XXXXXXXX (R, W)
0000004EH	CDCR0			0 - - - 0000 _B (R/W)
00000052H	CDCR2			0 - - - 0000 _B (R/W)

() : Access
 R/W : Read/Write enabled
 R : Read only
 W : Write only
 — : Not in use
 X : Undefined

3. PPG Timer

The PPG timer can output highly accurate PWM waveforms efficiently.

This device contains four PPG timer channels and its features are as follows :

- Each channel consists of a 16-bit down counter, a 16-bit data register attached with a frequency setting buffer, a 16-bit compare register attached with a duty setting buffer, and a pin controller.
- The count clock for the 16-bit down counter can be selected from the following four types :
Internal clocks ϕ , $\phi/4$, $\phi/16$, and $\phi/64$
- The counter value can be initialized by reset or counter borrow to “FFFF_H.”
- PWM output (by channel)

- **Block Diagram (Entire configuration)**

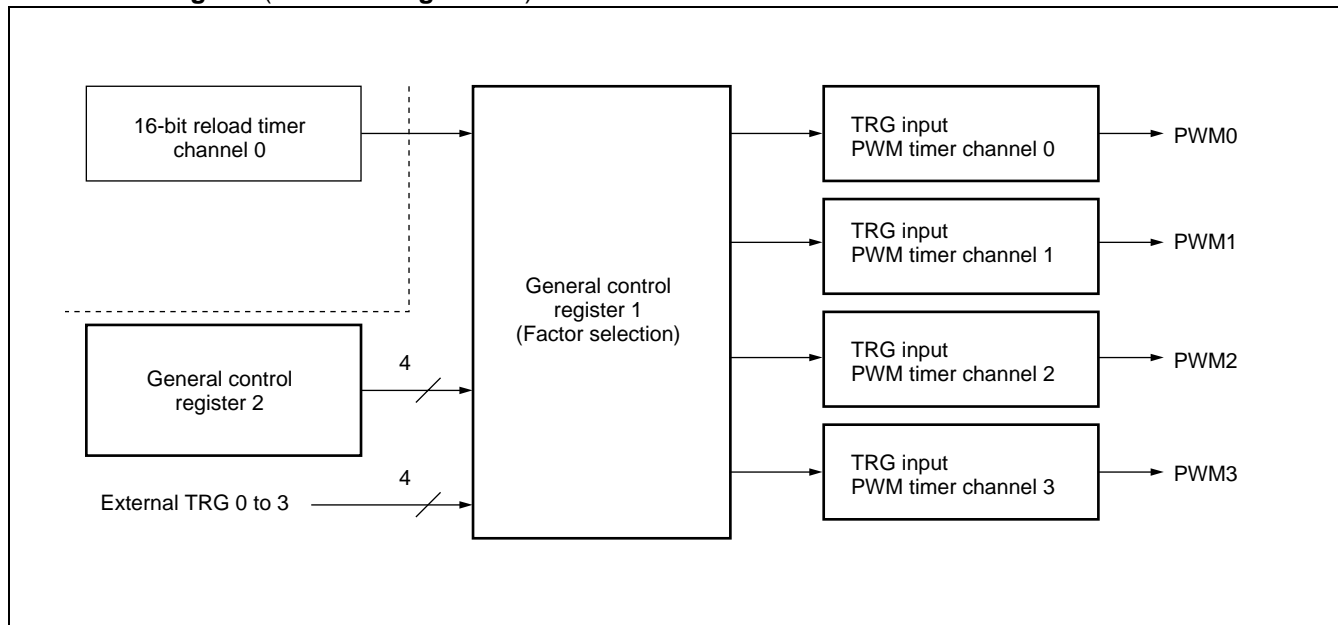

• Block Diagram (for one channel)

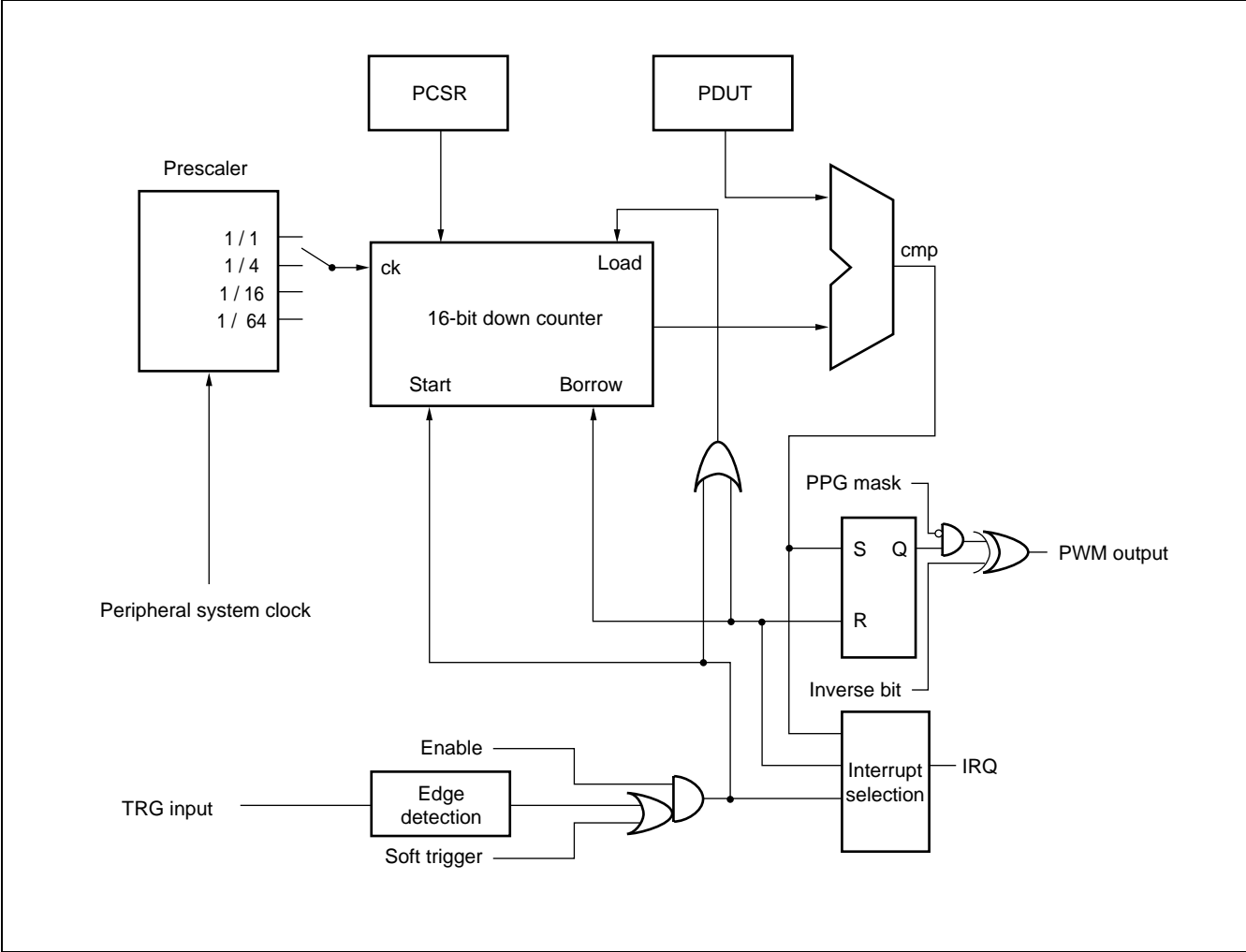

MB91F158

• Register List

Address	bit 15	bit 8	bit 0	Initial value
00000094H 00000095H	GCN1			00110010 _B (R/W) 00010000 _B (R/W)
00000097H		GCN2		00000000 _B (R/W)
00000098H 00000099H	PTMR0			11111111 _B (R) 11111111 _B (R)
0000009AH 0000009BH	PCSR0			XXXXXXXX _B (W) XXXXXXXX _B (W)
0000009CH 0000009DH	PDUT0			XXXXXXXX _B (W) XXXXXXXX _B (W)
0000009EH	PCNH0			0000000-B (R/W)
0000009FH		PCNL0		00000000 _B (R/W)
000000A0H 000000A1H	PTMR1			11111111 _B (R) 11111111 _B (R)
000000A2H 000000A3H	PCSR1			XXXXXXXX _B (W) XXXXXXXX _B (W)
000000A4H 000000A5H	PDUT1			XXXXXXXX _B (W) XXXXXXXX _B (W)
000000A6H	PCNH1			0000000-B (R/W)
000000A7H		PCNL1		00000000 _B (R/W)
000000A8H 000000A9H	PTMR2			11111111 _B (R) 11111111 _B (R)
000000AAH 000000ABH	PCSR2			XXXXXXXX _B (W) XXXXXXXX _B (W)
000000ACH 000000ADH	PDUT2			XXXXXXXX _B (W) XXXXXXXX _B (W)
000000AEH	PCNH2			0000000-B (R/W)
000000AFH		PCNL2		00000000 _B (R/W)
000000B0H 000000B1H	PTMR3			11111111 _B (R) 11111111 _B (R)
000000B2H 000000B3H	PCSR3			XXXXXXXX _B (W) XXXXXXXX _B (W)
000000B4H 000000B5H	PDUT3			XXXXXXXX _B (W) XXXXXXXX _B (W)
000000B6H	PCNH3			0000000-B (R/W)
000000B7H		PCNL3		00000000 _B (R/W)

() : Access R/W : Read/Write enabled R : Read only W : Write only — : Not in use X : Undefined

4. 16-bit Reload Timer

The 16-bit reload timer consists of a 16-bit down counter, a 16-bit reload register, a prescaler for creating internal count clocks, and a control register.

The input clock can be selected from three internal clock types (2/8/32 machine clock divisions) .

This product type contains this 16-bit reload timer for two channels.

• Block Diagram

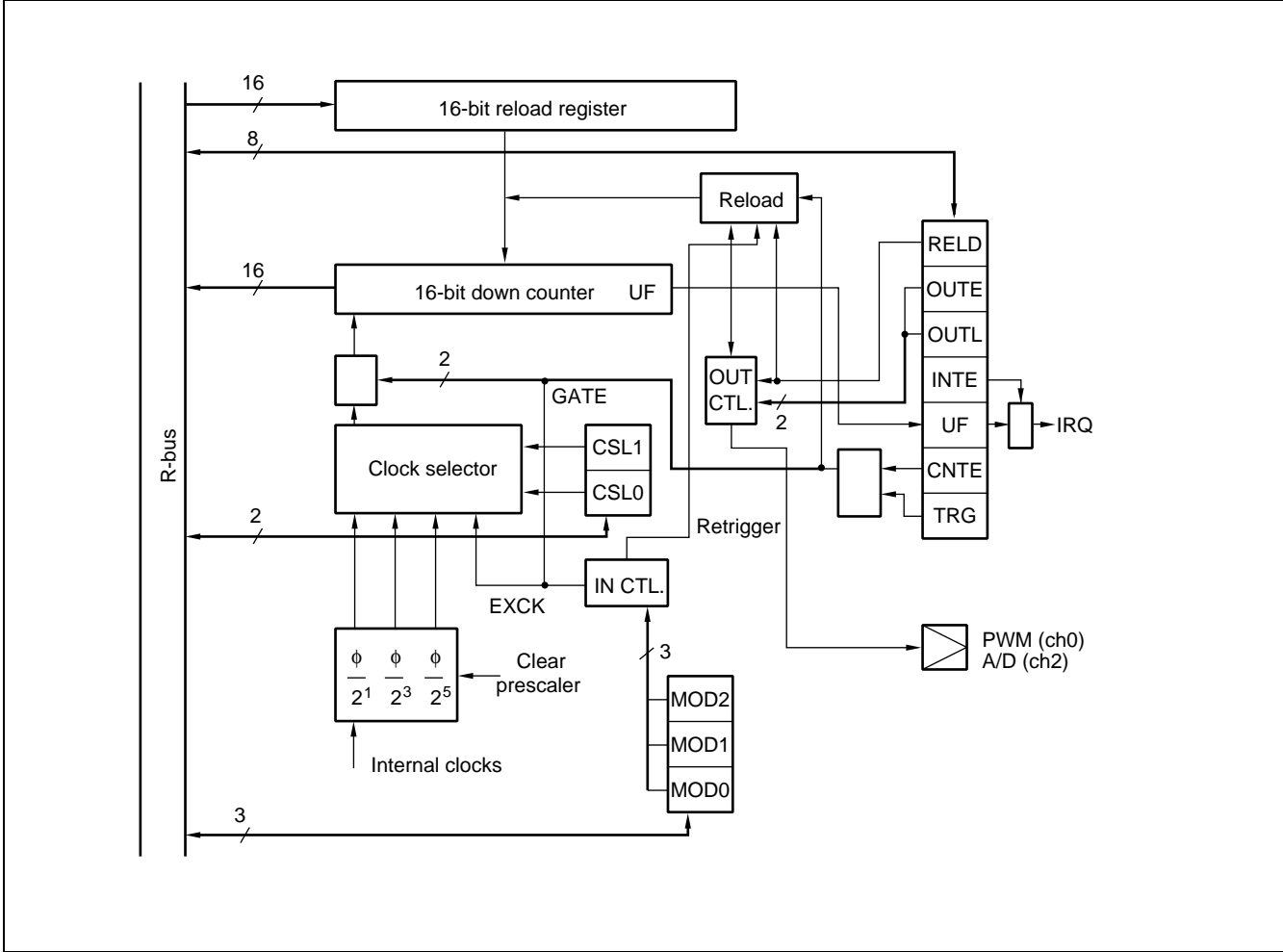

MB91F158

• Register List

Address	bit 15	bit 0	Initial value
00000032H 00000033H	TMCSR0		----0000 ^B (R/W) 00000000 ^B
00000042H 00000043H	TMCSR2		----0000 ^B (R/W) 00000000 ^B
0000002EH 0000002FH	TMR0		XXXXXXXX ^B (R) XXXXXXXX ^B
0000003EH 0000003FH	TMR2		XXXXXXXX ^B (R) XXXXXXXX ^B
0000002CH 0000002DH	TMRLR0		XXXXXXXX ^B (W) XXXXXXXX ^B
0000003CH 0000003DH	TMRLR2		XXXXXXXX ^B (W) XXXXXXXX ^B

() : Access
 R/W : Read/Write enabled
 R : Read only
 W : Write only
 — : Not in use
 X : Undefined

5. Bit Search Module

The module searches data written to the input register for "0" or "1" or a "change" and returns the detected bit position.

• Block Diagram

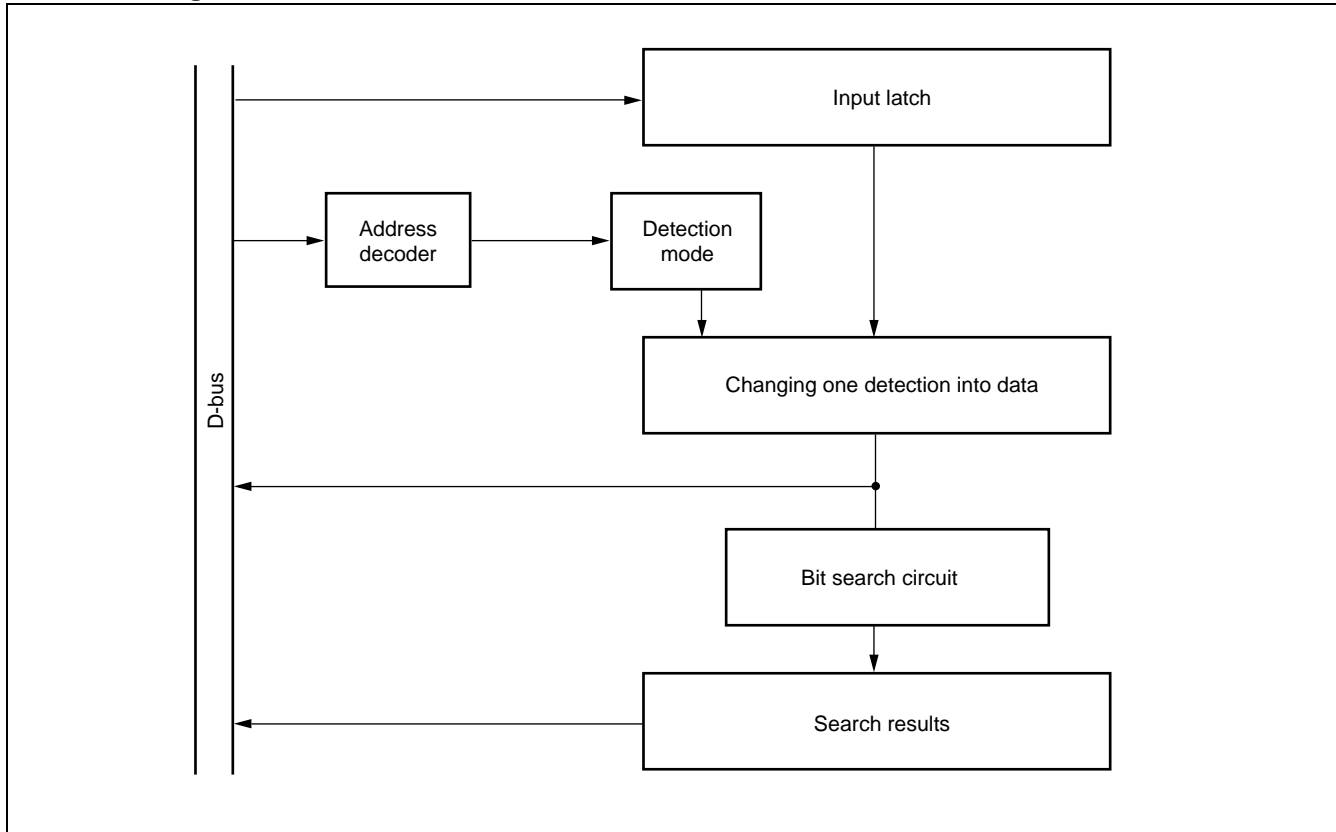

• Register List

Address	bit 31	bit 16	bit 0	Initial value
000003F0H	<div style="border: 1px solid black; padding: 2px; text-align: center;">BSD0</div>			XXXXXXXXXB
000003F1H				XXXXXXXXXB
000003F2H				XXXXXXXXXB (W)
000003F3H				XXXXXXXXXB
000003F4H	<div style="border: 1px solid black; padding: 2px; text-align: center;">BSD1</div>			XXXXXXXXXB
000003F5H				XXXXXXXXXB
000003F6H				XXXXXXXXXB (R/W)
000003F7H				XXXXXXXXXB
000003F8H	<div style="border: 1px solid black; padding: 2px; text-align: center;">BSDC</div>			XXXXXXXXXB
000003F9H				XXXXXXXXXB (W)
000003FAH				XXXXXXXXXB
000003FBH				XXXXXXXXXB
000003FCH	<div style="border: 1px solid black; padding: 2px; text-align: center;">BSRR</div>			XXXXXXXXXB
000003FDH				XXXXXXXXXB (R)
000003FEH				XXXXXXXXXB
000003FFH				XXXXXXXXXB

() : Access R/W : Read/Write enabled R : Read only
 W : Write only X : Undefined

6. 8/10-bit A/D Converter (Sequential Conversion Type)

The A/D converter is a module that converts analog input voltage into a digital value. Its features are as follows :

- A minimum conversion time of 5.2 $\mu\text{s}/\text{ch}$. (Including sampling time at a 32 MHz machine clock)
- Contains a sample and hold circuit.
- Resolution : 10 or 8 bits selectable.
- Selection of analog input from eight channels by program
 - Single conversion mode : Selects and converts one channel.
 - Continuous conversion mode : Converts a specified channel repeatedly.
 - Stop and convert mode : Stops after converting one channel and stands by until invoked the next time. (Conversion invoking can be synchronized.)
- Selection of an invoking factor from software, external pin trigger (falling edge) , and 16-bit reload timer (rising edge) .

• Block Diagram

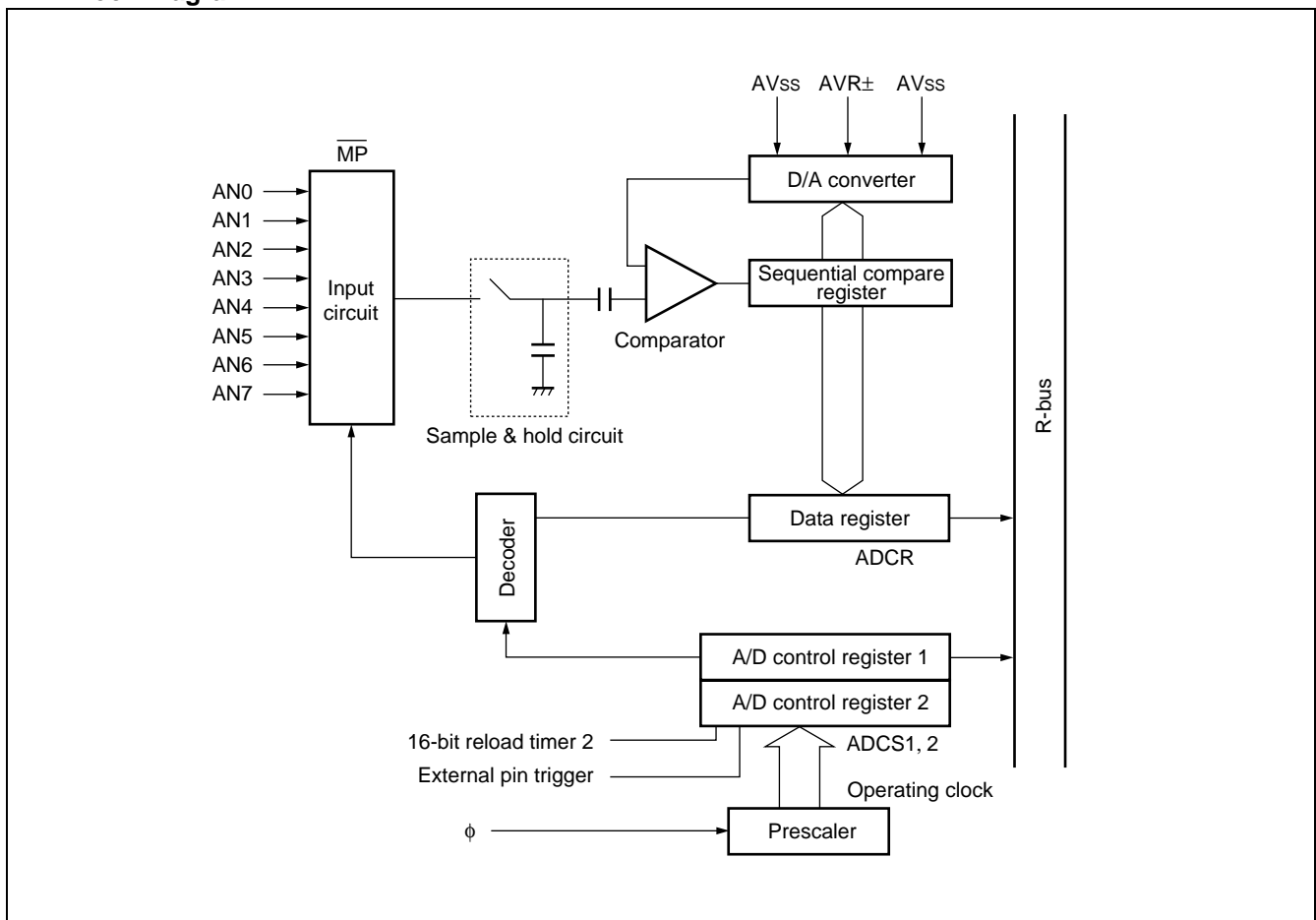

• Register List

	bit 15	bit 0	
000000E4H 000000E5H	ADCR		00101-XX _B (W, R) XXXXXXXXX _B (R)
000000E6H	ADCS1		00000000 _B (R/W, W)
000000E7H	ADCS0		00000000 _B (R/W)
000000EBH	AICK		00000000 _B (R/W)

() : Access
 R/W : Read/Write enabled
 R : Read only
 W : Write only
 — : Not in use
 X : Undefined

7. Interrupt Controller

The interrupt controller accepts and arbitrates interrupts.

• Block Diagram

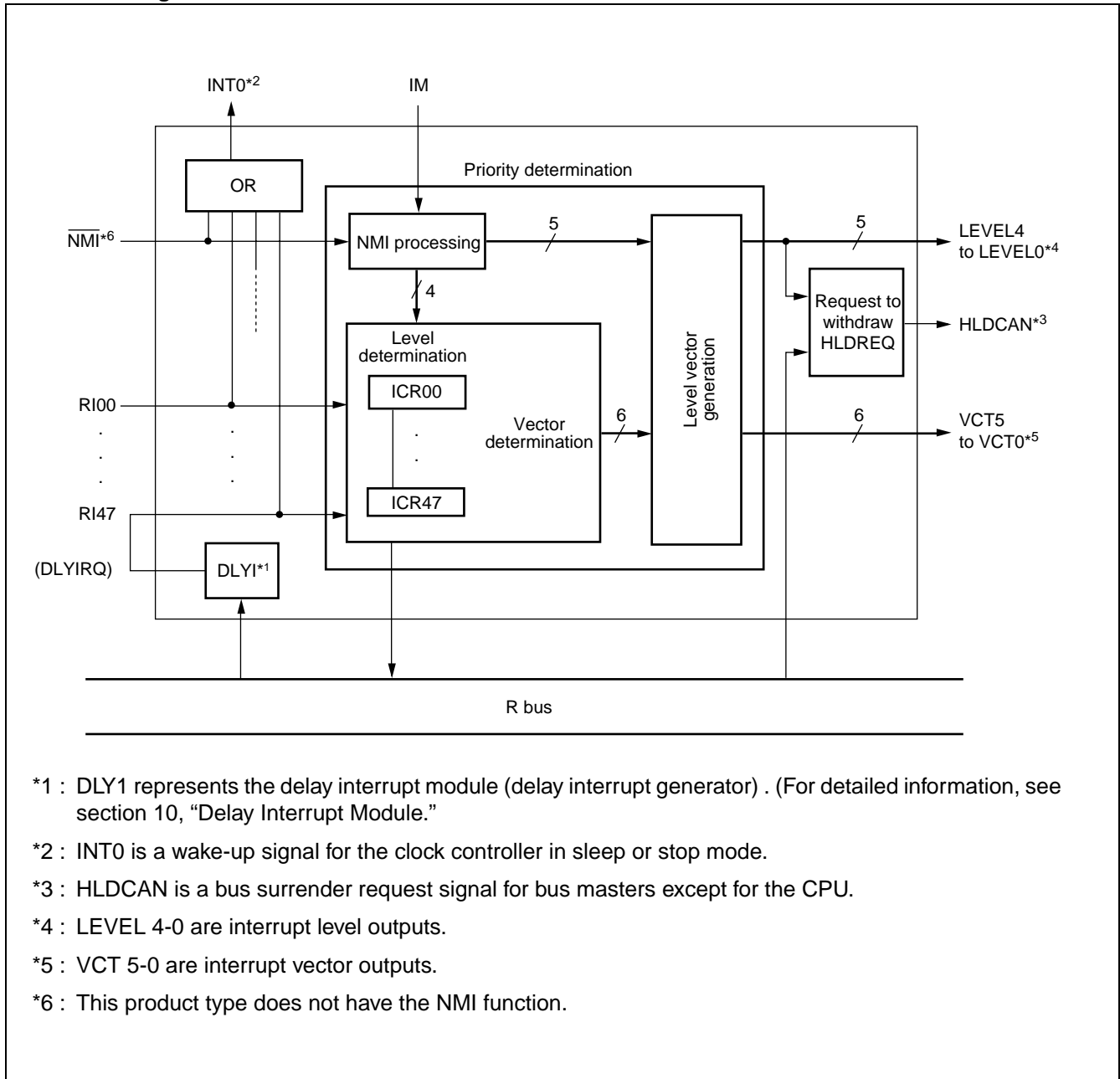

• Register List

Address	bit 7	bit 0	Initial value	Address	bit 7	bit 0	Initial value
00000400H	ICR00		----1111B (R/W)	00000414H	ICR20		----1111B (R/W)
00000401H	ICR01		----1111B (R/W)	00000415H	ICR21		----1111B (R/W)
00000402H	ICR02		----1111B (R/W)	00000416H	ICR22		----1111B (R/W)
00000403H	ICR03		----1111B (R/W)	00000417H	ICR23		----1111B (R/W)
00000404H	ICR04		----1111B (R/W)	00000418H	ICR24		----1111B (R/W)
00000405H	ICR05		----1111B (R/W)	00000419H	ICR25		----1111B (R/W)
00000406H	ICR06		----1111B (R/W)	0000041AH	ICR26		----1111B (R/W)
00000407H	ICR07		----1111B (R/W)	0000041BH	ICR27		----1111B (R/W)
00000408H	ICR08		----1111B (R/W)	0000041CH	ICR28		----1111B (R/W)
00000409H	ICR09		----1111B (R/W)	0000041DH	ICR29		----1111B (R/W)
0000040AH	ICR10		----1111B (R/W)	0000041EH	ICR30		----1111B (R/W)
0000040BH	ICR11		----1111B (R/W)	0000041FH	ICR31		----1111B (R/W)
0000040CH	ICR12		----1111B (R/W)	00000420H	ICR32		----1111B (R/W)
0000040DH	ICR13		----1111B (R/W)	00000421H	ICR33		----1111B (R/W)
0000040EH	ICR14		----1111B (R/W)	00000422H	ICR34		----1111B (R/W)
0000040FH	ICR15		----1111B (R/W)	00000423H	ICR35		----1111B (R/W)
00000410H	ICR16		----1111B (R/W)	00000424H	ICR36		----1111B (R/W)
00000411H	ICR17		----1111B (R/W)	00000425H	ICR37		----1111B (R/W)
00000412H	ICR18		----1111B (R/W)	00000426H	ICR38		----1111B (R/W)
00000413H	ICR19		----1111B (R/W)	00000427H	ICR39		----1111B (R/W)

() : Access
 R/W : Read/Write enabled
 — : Not in use

(Continued)

MB91F158

(Continued)

Address	bit 7	bit 0	Initial value
00000428H	<input type="checkbox"/> ICR40		---- 1 1 1 1 B (R/W)
00000429H	<input type="checkbox"/> ICR41		---- 1 1 1 1 B (R/W)
0000042AH	<input type="checkbox"/> ICR42		---- 1 1 1 1 B (R/W)
0000042BH	<input type="checkbox"/> ICR43		---- 1 1 1 1 B (R/W)
0000042CH	<input type="checkbox"/> ICR44		---- 1 1 1 1 B (R/W)
0000042DH	<input type="checkbox"/> ICR45		---- 1 1 1 1 B (R/W)
0000042EH	<input type="checkbox"/> ICR46		---- 1 1 1 1 B (R/W)
0000042FH	<input type="checkbox"/> ICR47		---- 1 1 1 1 B (R/W)
00000431H	<input type="checkbox"/> HRCL		---- 1 1 1 1 B (R/W)
00000430H	<input type="checkbox"/> DICR		----- 0 B (R/W)

() : Access
R/W : Read/Write enabled
— : Not in use

8. External Interrupt

The external interrupt controller controls external interrupt requests input to INT pins 0 through 15. The level of requests to be detected can be selected from "H," "L," rising edge, and falling edge.

• Block Diagram

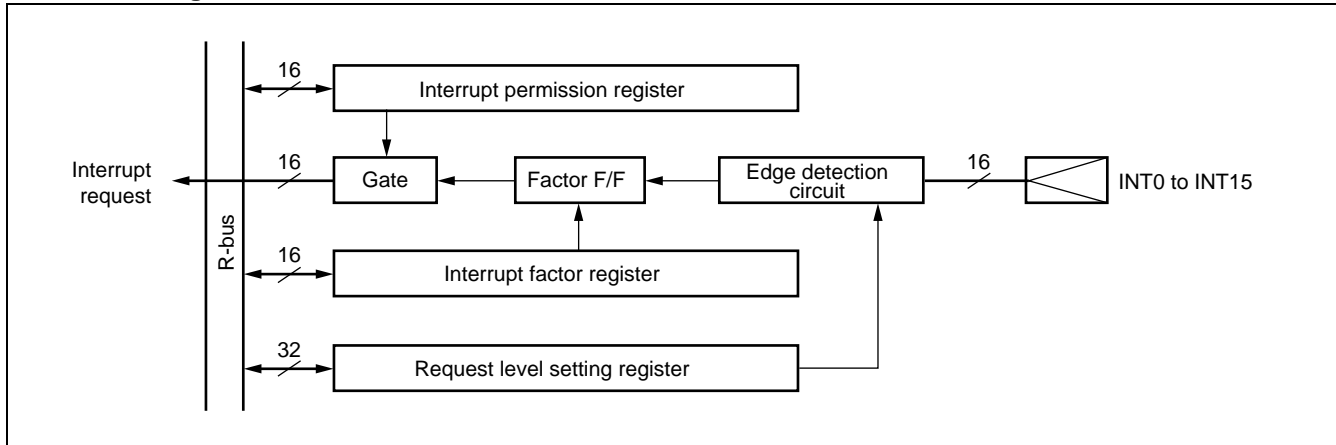

• Register List

Address	bit 15	bit 8	bit 0	Initial value
000000C8H 000000C9H	EIRR0		ENIR0	00000000 _B (R/W) 00000000 _B (R/W)
000000CAH 000000CBH	EIRR1		ENIR1	00000000 _B (R/W) 00000000 _B (R/W)
000000CCH 000000CDH	ELVR0			00000000 _B (R/W) 00000000 _B (R/W)
000000CEH 000000CFH	ELVR1			00000000 _B (R/W) 00000000 _B (R/W)

() : Access
R/W : Read/Write enabled

9. Delay Interrupt Module

The delay interrupt is a module that generates task switching interrupts. The use of this module allows the software to generate/cancel interrupt requests to the CPU.

For the block diagram of the delay interrupt module, see section 8, "Interrupt Controller."

• Register List

Address	bit 7	bit 0	Initial value
00000430H	DICR		----- 0 B (R/W)

() : Access
R/W : Read/Write enabled
— : Not in use

10. Clock Generator (Low power consumption mechanism)

The clock generator is responsible for the following functions :

- CPU clock generation (including the gear function)
- Peripheral clock generation (including the gear function)
- Reset generation and holding factors
- Standby function (including hardware standby)
- Contains PLL (multiplication circuit)

• Block Diagram

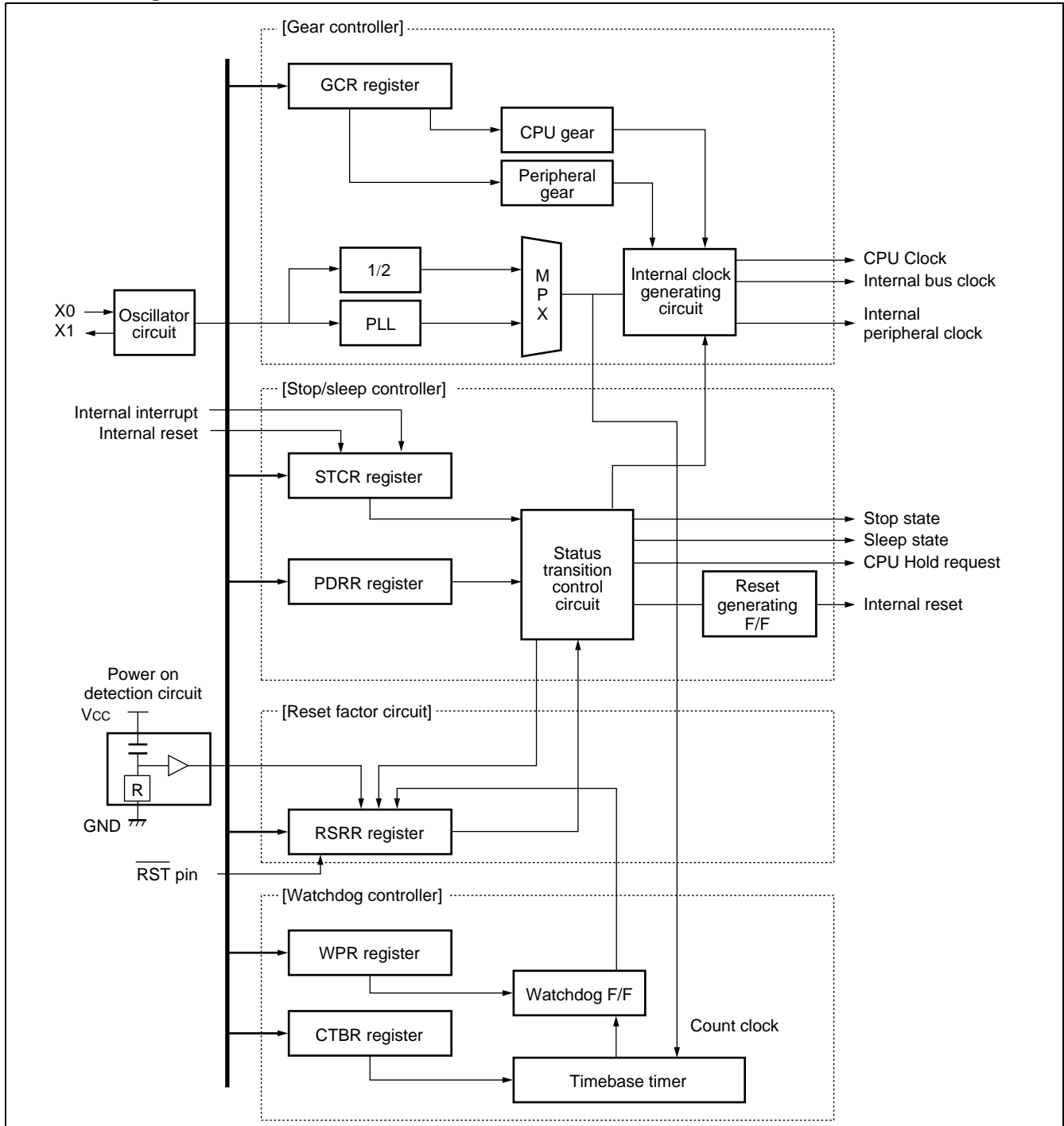

• Register List

Address	bit 15	bit 8	bit 0	Initial value
00000480H	RSRR/WTCH			1-XXX-00B (R, W)
00000481H		STCR		000111--B (R/W, W)
00000482H	PDRR			---0000B (R/W)
00000483H		CTBR		XXXXXXXXB (W)
00000484H	GCR			110011-1B (R/W, R)
00000485H		WPR		XXXXXXXXB (W)

() : Access
 R/W : Read/Write enabled
 R : Read only
 W : Write only
 — : Not in use
 X : Undefined

11. External Bus Interface

The external bus interface controls the interface between the external memory and the external I/O. Its features are as follows :

- 24-bit (16 MB) address output
- An 8/16-bit bus width can be set by chip select area.
- Inserts an automatic and programmable memory wait (for seven cycles at maximum) .
- Unused addresses/data pins are available as I/O ports.
- Support for little endian mode
- Use of a clock doubler, 32 MHz internal and 16 MHz external bus operations

• Block Diagram

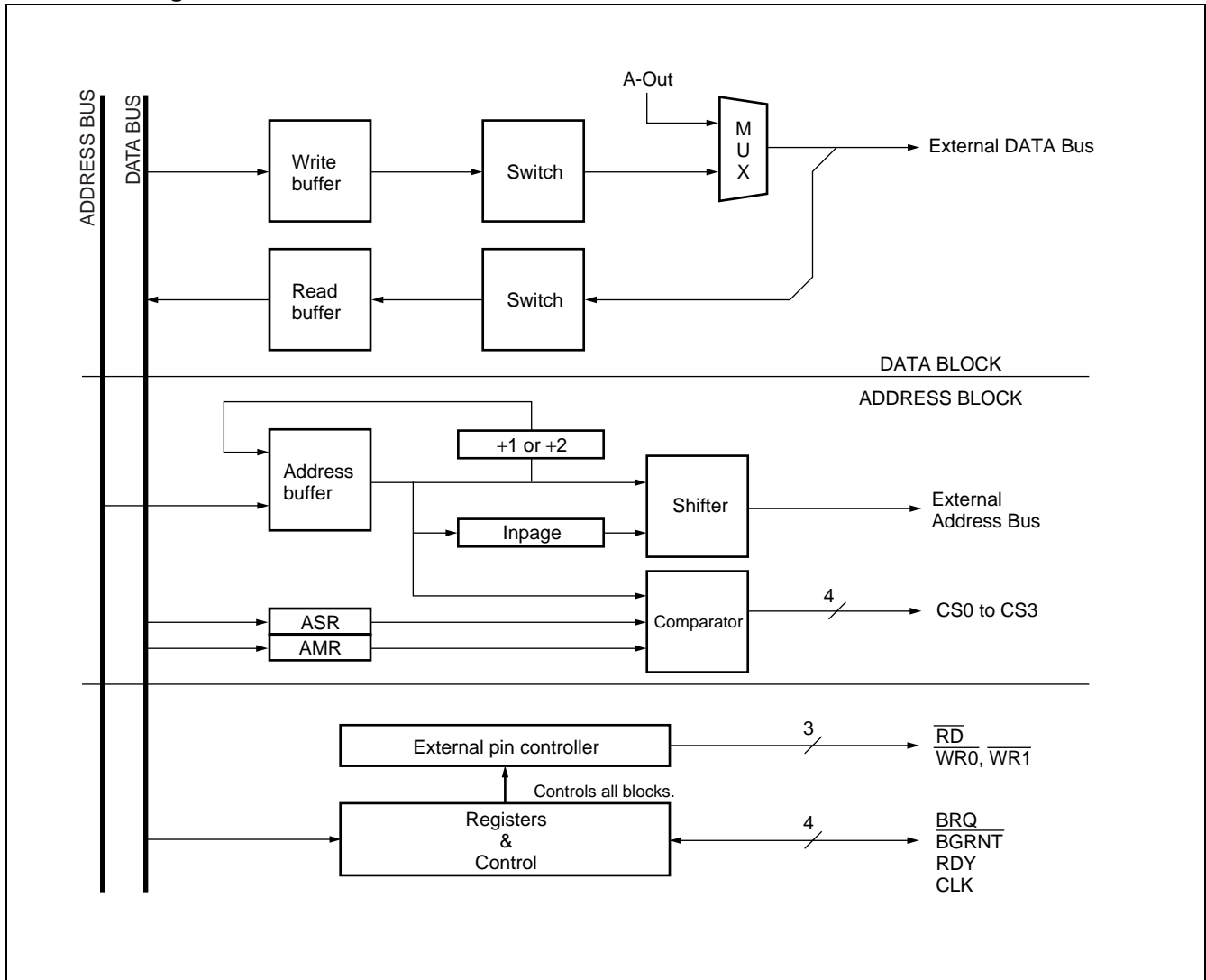

• Register List

Address	bit 31	bit 16	bit 0	Initial value
0000060CH 0000060DH	ASR1			00000000 _B (W) 00000001 _B
0000060EH 0000060FH		AMR1		00000000 _B (W) 00000000 _B
00000610H 00000611H	ASR2			00000000 _B (W) 00000010 _B
00000612H 00000613H		AMR2		00000000 _B (W) 00000000 _B
00000614H 00000615H	ASR3			00000000 _B (W) 00000011 _B
00000616H 00000617H		AMR3		00000000 _B (W) 00000000 _B
00000618H 00000619H	ASR4			00000000 _B (W) 00000100 _B
0000061AH 0000061BH		AMR4		00000000 _B (W) 00000000 _B
0000061CH 0000061DH	ASR5			00000000 _B (W) 00000101 _B
0000061EH 0000061FH		AMR5		00000000 _B (W) 00000000 _B
00000620H	AMD0			---00111 _B (R/W)
00000621H		AMD1		0--00000 _B (R/W)
00000622H		AMD32		00000000 _B (R/W)
00000623H			AMD4	0--00000 _B (R/W)
00000624H	AMD5			0--00000 _B (R/W)
00000628H 00000629H	EPCR0			----1100 _B (W) -1111111 _B
0000062AH 0000062BH		EPCR1		----- _B (W) 11111111 _B
000007FEH		LER		-----000 _B (W)
000007FFH			MODR	XXXXXXXX _B (W)

() : Access
 R/W : Read/Write enabled
 W : Write only
 — : Not in use
 X : Undefined

12. Multifunction Timer

The multifunction timer unit consists of one 16-bit free-run timer, four 16-bit output compare registers, four 16-bit input capture registers, and four 16-bit PPG timer channels. By using this function waveforms can be output based on the 16-bit free-run timer and the input pulse width and external clock cycle can also be measured.

- **Timer Components**

- 16-bit free-run timer (× 1)

The 16-bit free-run timer consists of a 16-bit up counter, a control register, a 16-bit compare clear register, and a prescaler. The output value of this counter is used as the basic time (base timer) for output compare and input capture.

- Output compare (× 4)

The output compare consists of four 16-bit compare registers, a compare output latch, and a control register. When the 16-bit free-run timer value agrees to the compare register value, the output level can be inverted and an interrupt can also be generated.

- Input capture (× 4)

The input capture consists of capture registers corresponding to four independent external input pins and a control register. By detecting any edge of signals input from external input pins, the 16-bit free-run timer value can be held in the capture register and an interrupt can be generated at the same time.

- 16-bit PPG timer (× 4)

See the section on the PPG Timer.

• Block Diagram

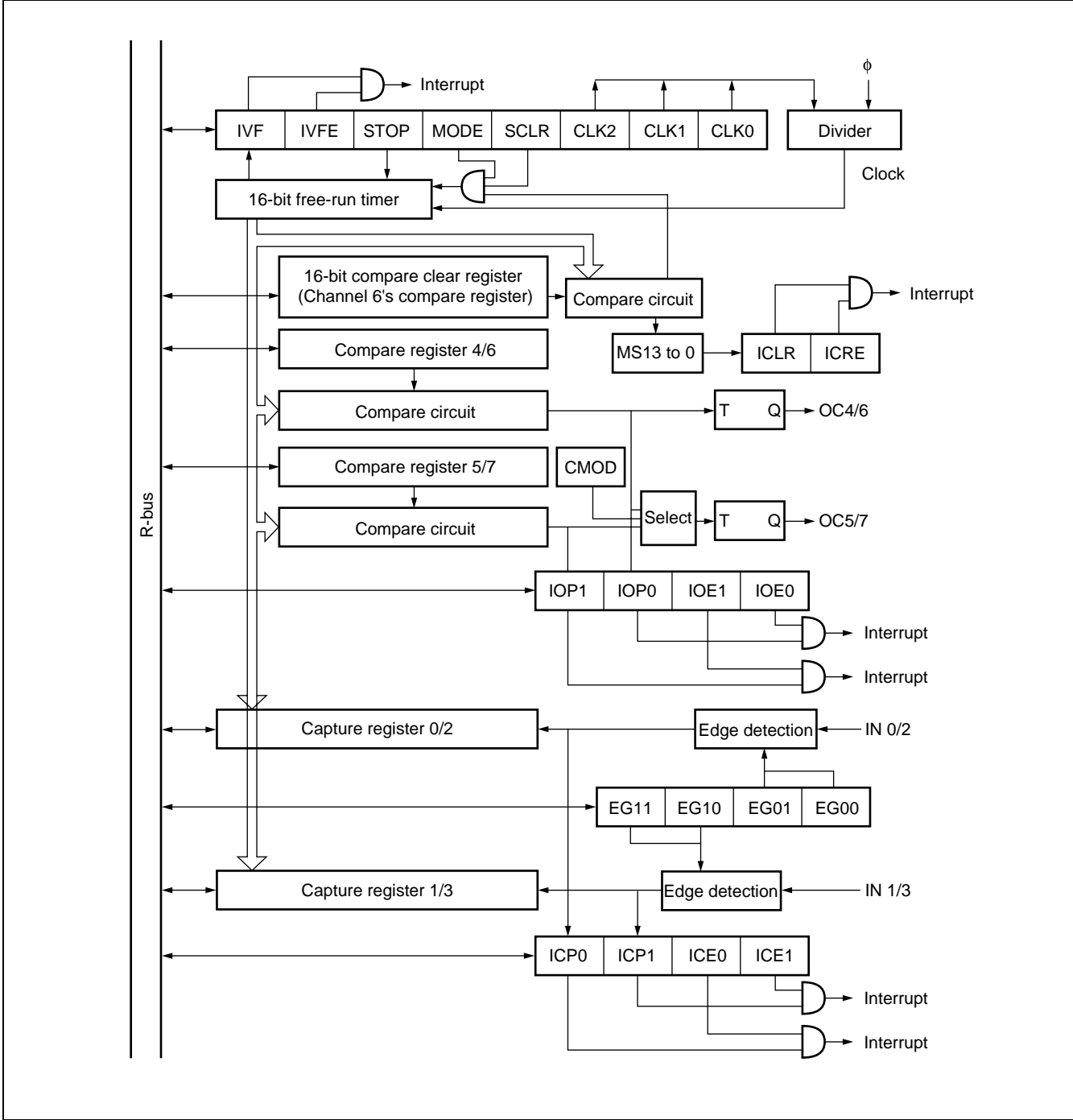

MB91F158

• Register List

Address		Initial value
000068 _H 000069 _H	IPCP1	XXXXXXXX _B (R) XXXXXXXX _B (R)
00006A _H 00006B _H	IPCP0	XXXXXXXX _B (R) XXXXXXXX _B (R)
00006C _H 00006D _H	IPCP3	XXXXXXXX _B (R) XXXXXXXX _B (R)
00006E _H 00006F _H	IPCP2	XXXXXXXX _B (R) XXXXXXXX _B (R)
000071 _H	ICS23	00000000 _B (R/W)
000073 _H	ICS01	00000000 _B (R/W)
00007C _H 00007D _H	OCCP5	XXXXXXXX _B (R/W) XXXXXXXX _B (R/W)
00007E _H 00007F _H	OCCP4	XXXXXXXX _B (R/W) XXXXXXXX _B (R/W)
000080 _H 000081 _H	OCCP7	XXXXXXXX _B (R/W) XXXXXXXX _B (R/W)
000082 _H 000083 _H	OCCP6	XXXXXXXX _B (R/W) XXXXXXXX _B (R/W)
000088 _H 000089 _H	OCS7, OCS6	XXX00000 _B (R/W) 0000XX00 _B (R/W)
00008A _H 00008B _H	OCS5, OCS4	XXX00000 _B (R/W) 0000XX00 _B (R/W)
00008C _H 00008D _H	TCDT	00000000 _B (R/W) 00000000 _B (R/W)
00008E _H 00008F _H	TCCS	0----- _B (R/W) 00000000 _B (R/W)

() : Access R/W : Read/Write enabled R : Read only — : Not in use X : Undefined

13. FLASH Memory

The MB91F158 contains a 510-Kbyte (4 Mbits) flash memory. The sectors can be erased all at once or sector by sector and that can be written with the FR-CPU by half word (16 bits) using a single 0.3 V power supply.

The MB91F158 accomplishes the following functions by a combination of the flash memory macro and the FR-CPU interface circuit :

- Functions as the CPU program/data storage memory :
 - When used as a ROM, the memory is accessible with a 32-bit bus width.
 - Allows the CPU to read from/write to/erase the memory (automatic program algorithm*).
- Functions equivalent to the stand-alone MBM29LV400C flash memory product :
 - Allows a ROM programmer to read from/write to/erase the memory (automatic program algorithm*)

At this time, using the flash memory from the FR-CPU is described. For detailed information about using the flash memory from the ROM programmer, refer to the ROM programmer instruction manual.

* : Automatic program algorithm = Embedded Algorithm™
 Embedded Algorithm™ is a trademark of Advanced Micro Devices, Inc.

• Block Diagram

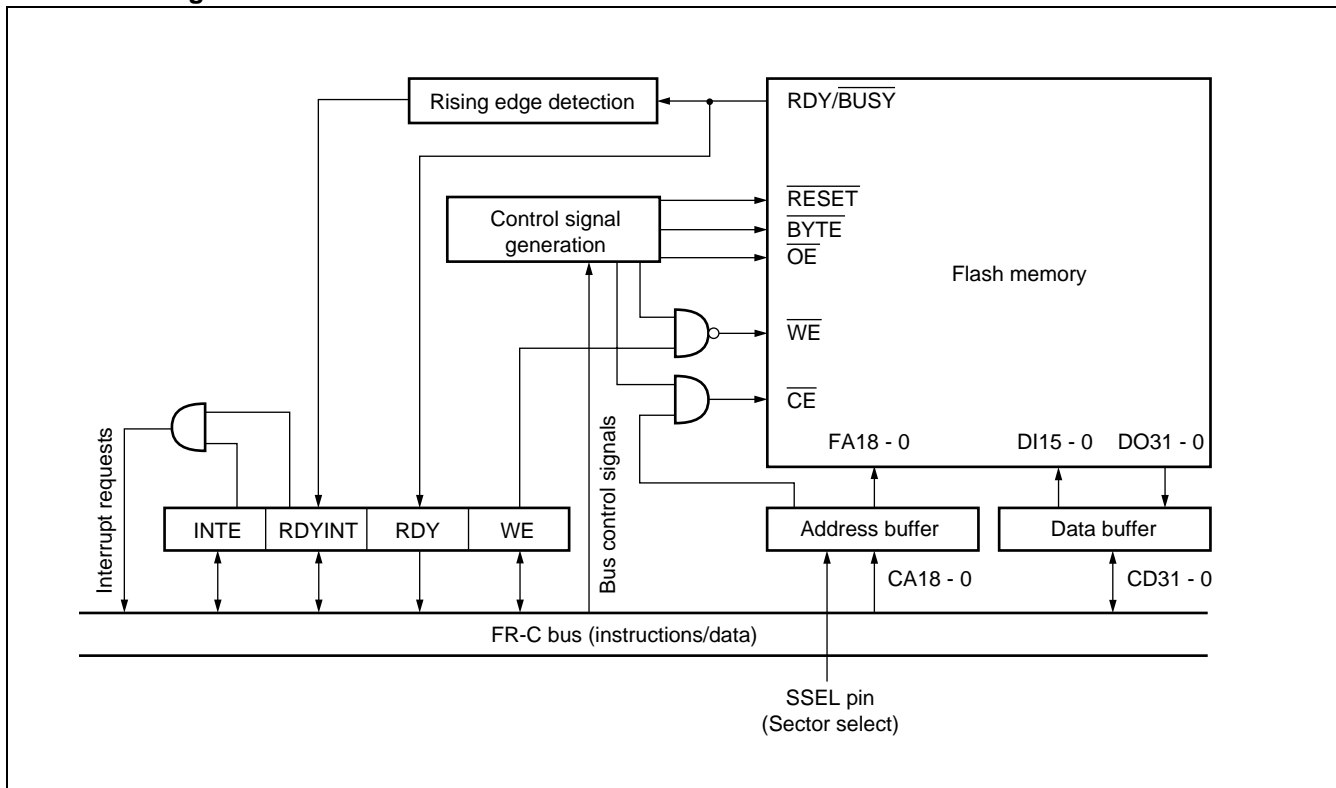

MB91F158

• Memory Map

Flash memory address mapping varies between FLASH memory mode and CPU mode. Mapping in each mode is shown next.

Memory mapping in FLASH memory mode of MB91F158 :

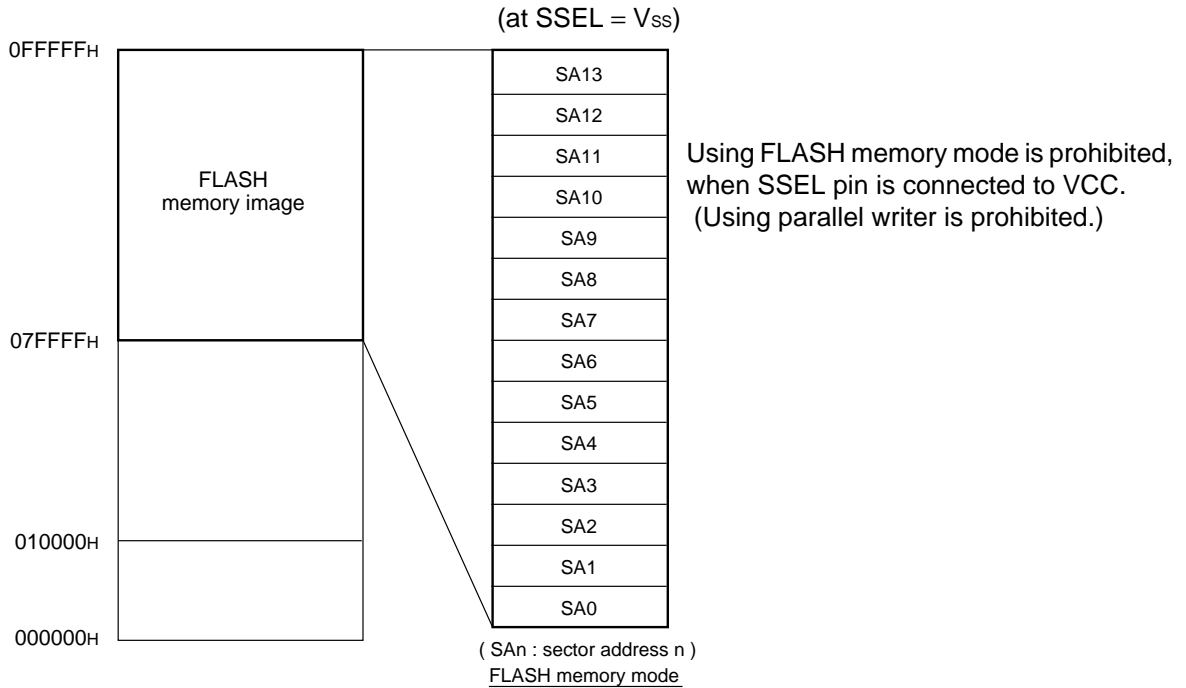

Memory mapping in CPU mode of MB91F158A :

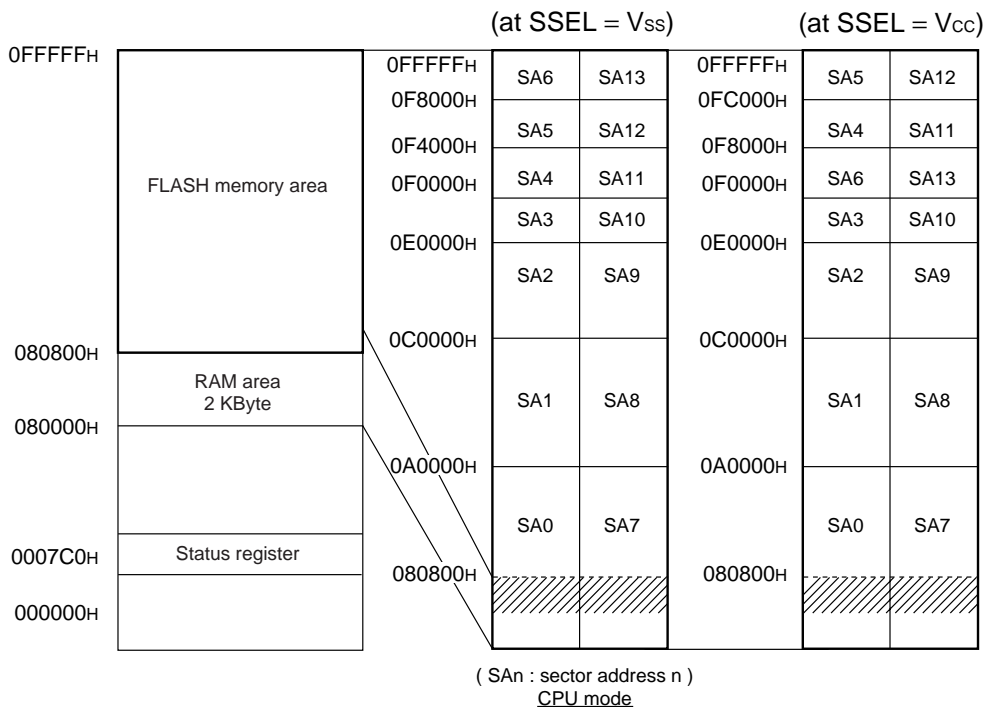

• Sector Address Table

< SSEL = V_{SS} >

Sector address	Address range	Corresponding bit positions	Sector capacity
SA7	080802, 3 _H to 09FFFE, F _H (16 bits on LSB side)	bit15 to 0	64 Kbyte
SA8	0A0002, 3 _H to 0BFFFE, F _H (16 bits on LSB side)	bit15 to 0	64 Kbyte
SA9	0C0002, 3 _H to 0DFFFE, F _H (16 bits on LSB side)	bit15 to 0	64 Kbyte
SA10	0E0002, 3 _H to 0EFFFFE, F _H (16 bits on LSB side)	bit15 to 0	32 Kbyte
SA11	0F0002, 3 _H to 0F3FFE, F _H (16 bits on LSB side)	bit15 to 0	8 Kbyte
SA12	0F4002, 3 _H to 0F7FFE, F _H (16 bits on LSB side)	bit15 to 0	8 Kbyte
SA13	0F8002, 3 _H to 0FFFFE, F _H (16 bits on LSB side)	bit15 to 0	16 Kbyte
SA0	080800, 1 _H to 09FFFC, D _H (16 bits on MSB side)	bit31 to 16	64 Kbyte
SA1	0A0000, 1 _H to 0BFFFC, D _H (16 bits on MSB side)	bit31 to 16	64 Kbyte
SA2	0C0000, 1 _H to 0DFFFC, D _H (16 bits on MSB side)	bit31 to 16	64 Kbyte
SA3	0E0000, 1 _H to 0EFFFFC, D _H (16 bits on MSB side)	bit31 to 16	32 Kbyte
SA4	0F0000, 1 _H to 0F3FFC, D _H (16 bits on MSB side)	bit31 to 16	8 Kbyte
SA5	0F4000, 1 _H to 0F7FFC, D _H (16 bits on MSB side)	bit31 to 16	8 Kbyte
SA6	0F8000, 1 _H to 0FFFFC, D _H (16 bits on MSB side)	bit31 to 16	16 Kbyte

< SSEL = V_{CC} >

Sector address	Address range	Corresponding bit positions	Sector capacity
SA7	080802, 3 _H to 09FFFE, F _H (16 bits on LSB side)	bit15 to 0	64 Kbyte
SA8	0A0002, 3 _H to 0BFFFE, F _H (16 bits on LSB side)	bit15 to 0	64 Kbyte
SA9	0C0002, 3 _H to 0DFFFE, F _H (16 bits on LSB side)	bit15 to 0	64 Kbyte
SA10	0E0002, 3 _H to 0EFFFFE, F _H (16 bits on LSB side)	bit15 to 0	32 Kbyte
SA13	0F0002, 3 _H to 0F7FFE, F _H (16 bits on LSB side)	bit15 to 0	16 Kbyte
SA11	0F8002, 3 _H to 0FBFFE, F _H (16 bits on LSB side)	bit15 to 0	8 Kbyte
SA12	0FC002, 3 _H to 0FFFFE, F _H (16 bits on LSB side)	bit15 to 0	8 Kbyte
SA0	080800, 1 _H to 09FFFC, D _H (16 bits on MSB side)	bit31 to 16	64 Kbyte
SA1	0A0000, 1 _H to 0BFFFC, D _H (16 bits on MSB side)	bit31 to 16	64 Kbyte
SA2	0C0000, 1 _H to 0DFFFC, D _H (16 bits on MSB side)	bit31 to 16	64 Kbyte
SA3	0E0000, 1 _H to 0EFFFFC, D _H (16 bits on MSB side)	bit31 to 16	32 Kbyte
SA6	0F0000, 1 _H to 0F7FFC, D _H (16 bits on MSB side)	bit31 to 16	16 Kbyte
SA4	0F8000, 1 _H to 0FBFFC, D _H (16 bits on MSB side)	bit31 to 16	8 Kbyte
SA5	0FC000, 1 _H to 0FFFFC, D _H (16 bits on MSB side)	bit31 to 16	8 Kbyte

MB91F158

- Registers

FLCR : Status register (CPU mode)

This register indicates the FLASH memory operating status. The register controls interrupts to the CPU as well as writing to the FLASH memory.

This register is accessible only in CPU mode. Do not access this register with read modify write instructions.

	bit 7	bit 6	bit 5	bit 4	bit 3	bit 2	bit 1	bit 0
0007C0H	INTE	RDYINT	WE	RDY	—	—	—	LPM
	R/W (0)	R/W (0)	R/W (0)	R (X)	— (X)	— (X)	— (X)	R/W (0)

R/W : Read/Write enabled, R : Read only, — : Not in use, X : Undefined

FWTC : Wait register

This register controls waiting for the FLASH memory in CPU mode.

The register also controls accessing to read from the FLASH memory (33 MHz operations) at high speeds.

	bit 7	bit 6	bit 5	bit 4	bit 3	bit 2	bit 1	bit 0
0007C4H	—	—	—	—	—	SYNC	WTC1	WTC0
	W (1)	W (0)	W (0)	W (1)	W (0)	W (1)	R/W (0)	R/W (0)

R/W : Read/Write enabled, W : Write only, — : Not in use, X : Undefined

14. 8-bit D/A Converter

This block is of an 8-bit resolution, R-2R D/A converter. The block contains three D/A converter channels and each D/A control register can control output independently. The D/A converter pin is a dedicated pin.

• Block Diagram

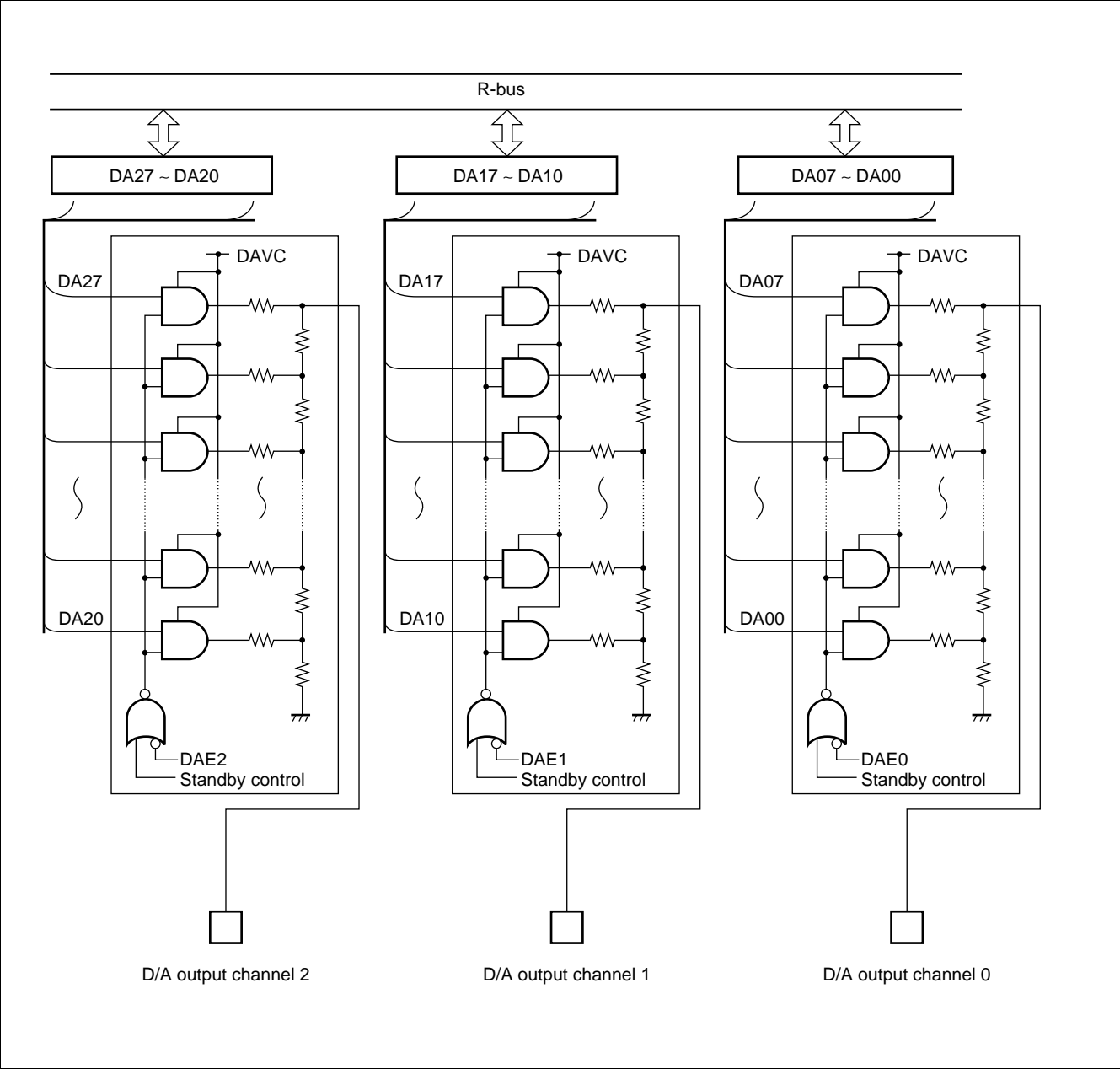

MB91F158

• Register List

DADR0 00000E3H	bit	7	6	5	4	3	2	1	0	Initial value
		DA07	DA06	DA05	DA04	DA03	DA02	DA01	DA00	XXXXXXXXB (R/W)
DADR1 00000E2H	bit	15	14	13	12	11	10	9	8	Initial value
		DA17	DA16	DA15	DA14	DA13	DA12	DA11	DA10	XXXXXXXXB (R/W)
DADR2 00000E1H	bit	23	22	21	20	19	18	17	16	Initial value
		DA27	DA26	DA25	DA24	DA23	DA22	DA21	DA20	XXXXXXXXB (R/W)
DACR0 00000DFH	bit	7	6	5	4	3	2	1	0	Initial value
		—	—	—	—	—	—	—	DAE0	-----0B (R/W)
DACR1 00000DEH	bit	15	14	13	12	11	10	9	8	Initial value
		—	—	—	—	—	—	—	DAE1	-----0B (R/W)
DACR2 00000DDH	bit	23	22	21	20	19	18	17	16	Initial value
		—	—	—	—	—	—	—	DAE2	-----0B (R/W)

() : Access, R/W : Read/Write enabled, — : Not in use, X : Undefined

15. 8/16-bit Up/Down Counters/Timers

This is the up/down counter/timer block consisting of six event input pins, two 8-bit up/down counters, two 8-bit reload/compare registers, and their control circuits.

The features of this module are as follows :

- Capable of counting in the (0) d- (256) d range by the 8-bit count register.
(In 16-bit \times 1 operating mode, the register can count in the (0) d- (65535) d range.)
- Four count modes to choose from by the count clock.
- In timer mode the count clock can be selected from two internal clock types.
- In up/down count mode an external pin input signal detection edge can be selected.
- The phase-difference count mode is suitable for encoder counting, such as of motors. Rotation angles, rotating speeds, and so on can be counted accurately and easily by inputting the output of phases A, B, and Z.
- Two types of function to choose from for the ZIN pin. (Enabled in all modes)
- Equipped with compare and reload functions which can be used individually or in combination. When combined, these functions can count up/down at any width.
- The immediately preceding count direction can be identified by the count direction flag.
- Capable of individually controlling interrupt generation when comparison results match, at occurrence of reload (underflow) or overflow, or when the count direction changes.

MB91F158

• Block Diagram

• 8/16-bit Up/Down Counter/Timer (channel 0)

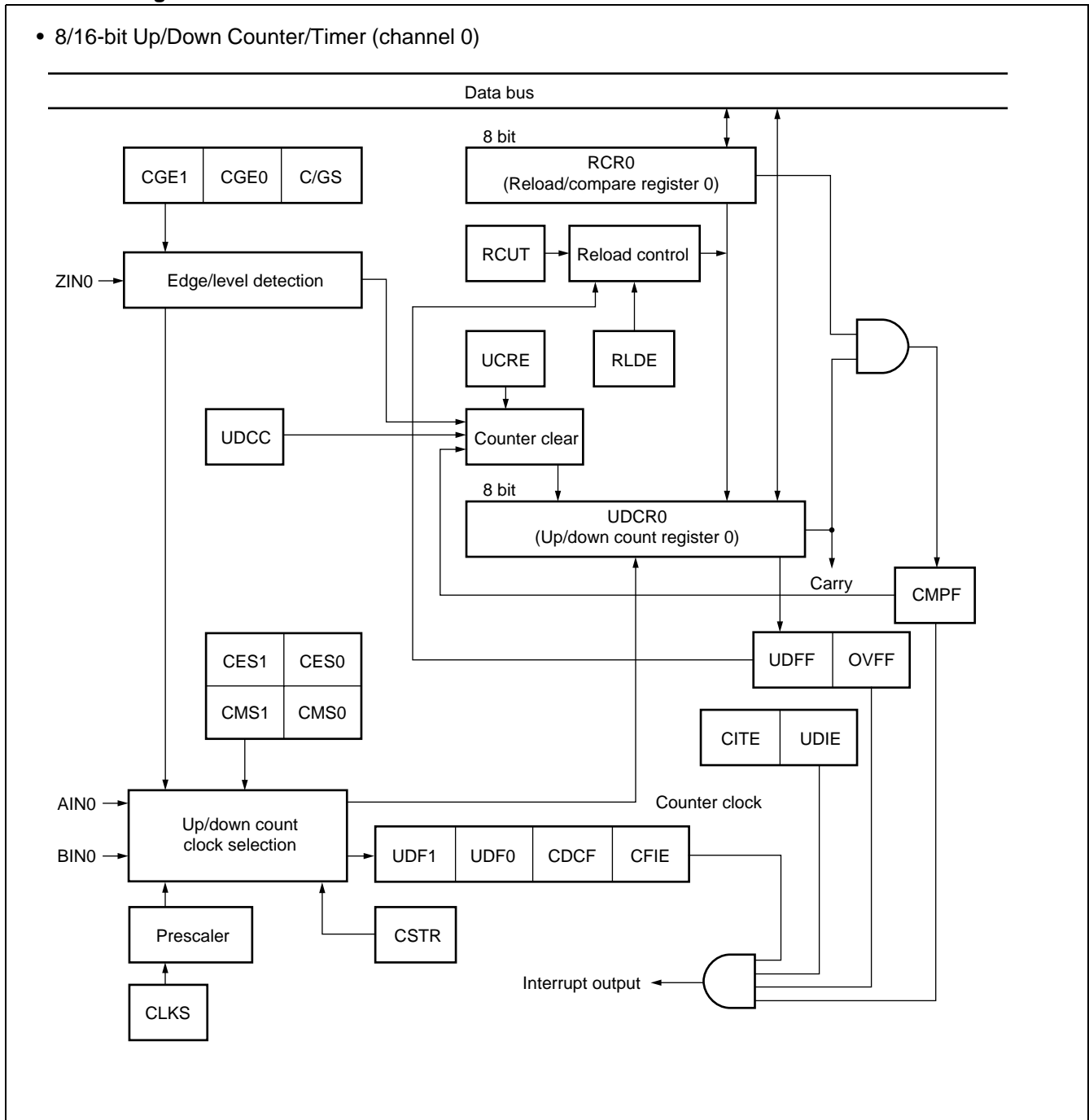

• 8/16-bit Up/Down Counter/Timer (channel 1)

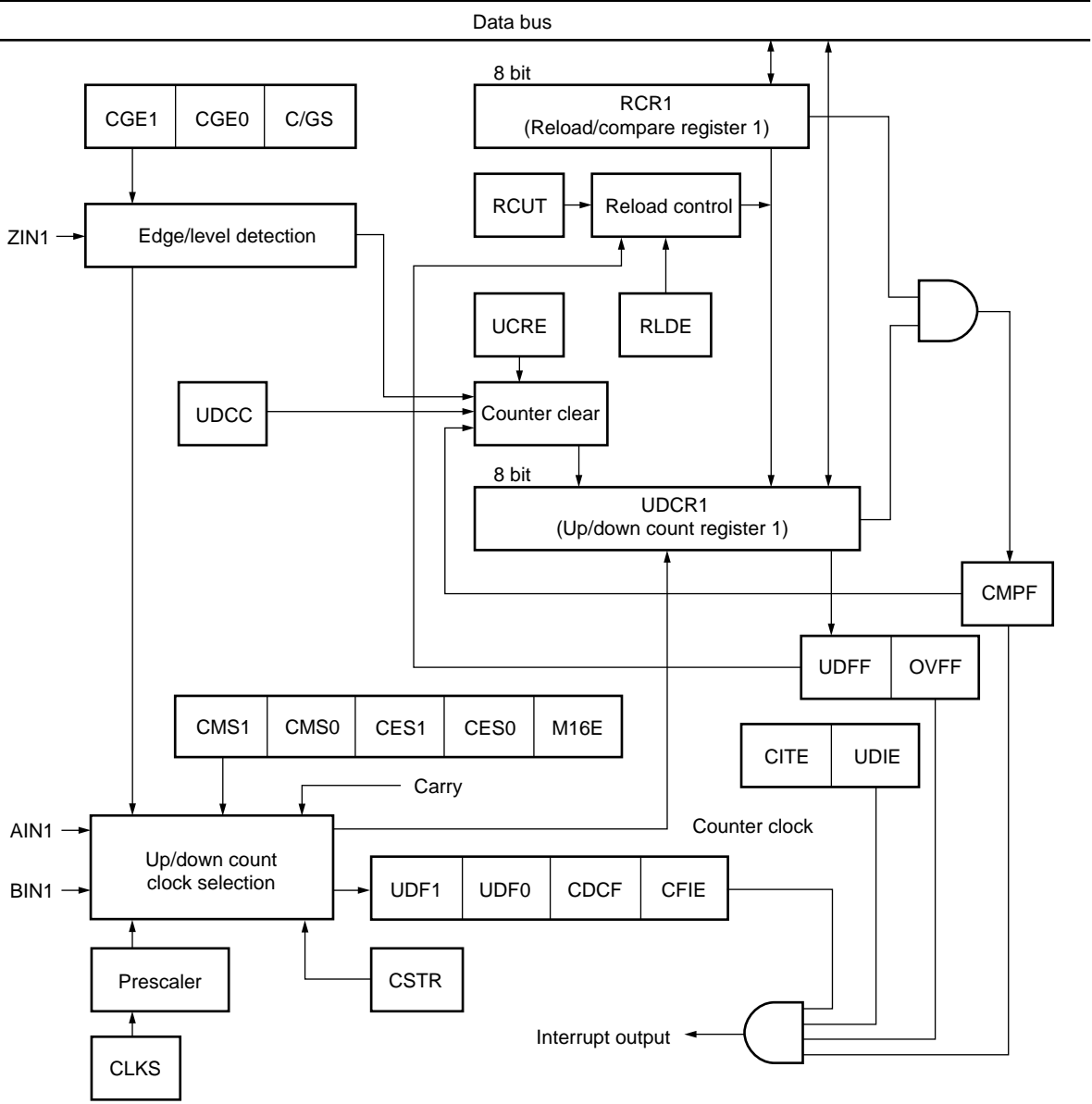

MB91F158

• Register List

Address : 00005FH	bit	7	6	5	4	3	2	1	0	Initial value	
		UDCR0								00000000 _B	(R)
Address : 00005EH	bit	15	14	13	12	11	10	9	8	Initial value	
		UDCR1								00000000 _B	(R)
Address : 00005DH	bit	7	6	5	4	3	2	1	0	Initial value	
		RCR0								00000000 _B	(W)
Address : 00005CH	bit	15	14	13	12	11	10	9	8	Initial value	
		RCR1								00000000 _B	(W)
Address : 000063H	bit	7	6	5	4	3	2	1	0	Initial value	
		CSR0								00000000 _B	(R/W)
Address : 000067H	bit	7	6	5	4	3	2	1	0	Initial value	
		CSR1								00000000 _B	(R/W)
Address : 000061H	bit	7	6	5	4	3	2	1	0	Initial value	
		CCRL0								-000X000 _B	(R/W, W)
Address : 000065H	bit	7	6	5	4	3	2	1	0	Initial value	
		CCRL1								-000X000 _B	(R/W, W)
Address : 000060H	bit	15	14	13	12	11	10	9	8	Initial value	
		CCRH0								00000000 _B	(R/W)
Address : 000064H	bit	15	14	13	12	11	10	9	8	Initial value	
		CCRH1								-0000000 _B	(R/W)

() : Access, R/W : Read/Write enabled, R : Read only, W : Write only, — : Not in use, X : Undefined

16. Peripheral STOP Control

This function can be used to stop the clock of unused resources in order to conserve more power.

• Register List

Address	bit7 bit0	Initial value
000090H	STPR0	0- 0- - - - B (R/W)
000091H	STPR1	0- 0- 0- 00B (R/W)
000092H	STPR2	0000- - - - B (R/W)

() : Access, R/W : Read/Write enabled, — : Not in use

MB91F158

■ ELECTRICAL CHARACTERISTICS

1. Absolute Maximum Ratings

($V_{SS} = AV_{SS} = 0.0\text{ V}$)

Parameter	Symbol	Rating		Unit	Remarks
		Min	Max		
Power supply voltage	V_{CC}	$V_{SS} - 0.3$	$V_{SS} + 3.5$	V	
Analog supply voltage	AV_{CC}	$V_{SS} - 0.3$	$V_{SS} + 3.5$	V	*1
Analog reference voltage	AV_{RH}	$V_{SS} - 0.3$	$V_{SS} + 3.5$	V	*1
Input voltage	V_I	$V_{SS} - 0.3$	$V_{CC} + 0.3$	V	
Analog pin input voltage	V_{IA}	$V_{SS} - 0.3$	$AV_{CC} + 0.3$	V	
Output voltage	V_O	$V_{SS} - 0.3$	$V_{CC} + 0.3$	V	
"L" level maximum output current	I_{OL}	—	10	mA	*2
"L" level average output current	I_{OLAV}	—	4	mA	*3
"L" level total maximum output current	ΣI_{OL}	—	100	mA	
"L" level total average output current	ΣI_{OLAV}	—	50	mA	*4
"H" level maximum output current	I_{OH}	—	-10	mA	*2
"H" level average output current	I_{OHAV}	—	-4	mA	*3
"H" level total maximum output current	ΣI_{OH}	—	-50	mA	
"H" level total average output current	ΣI_{OHAV}	—	-20	mA	*4
Power consumption	P_D	—	500	mW	
Operating temperature	T_A	0	+70	°C	
Storage temperature	T_{stg}	-55	+150	°C	

*1 : Take care not to exceed $V_{CC} + 0.3\text{ V}$ when turning on the power, for example.
Take care also to prevent AV_{CC} from exceeding V_{CC} when turning on the power, for example.

*2 : The maximum output current stipulates the peak value of a single concerned pin.

*3 : The average output current stipulates the average current flowing through a single concerned pin over a period of 100 ms.

*4 : The total average output current stipulates the average current flowing through all concerned pins over a period of 100 ms.

WARNING: Semiconductor devices can be permanently damaged by application of stress (voltage, current, temperature, etc.) in excess of absolute maximum ratings. Do not exceed these ratings.

2. Recommended Operating Conditions

($V_{SS} = AV_{SS} = 0.0\text{ V}$)

Parameter	Symbol	Value		Unit	Remarks
		Min	Max		
Power supply voltage	V_{CC}	3.2	3.5	V	During normal operations.
		2.0	3.5		The RAM state is retained when stopped.
Analog supply voltage	AV_{CC}	$V_{SS} + 3.2$	$V_{SS} + 3.5$	V	
Analog reference voltage (High potential side)	AV_{RH}	$AV_{CC} - 0.3$	AV_{CC}	V	
Analog reference voltage (Low potential side)	AV_{RL}	AV_{SS}	$AV_{SS} + 0.3$	V	
Operating temperature	T_A	0	+70	°C	

WARNING: The recommended operating conditions are required in order to ensure the normal operation of the semiconductor device. All of the device's electrical characteristics are warranted when the device is operated within these ranges.

Always use semiconductor devices within their recommended operating condition ranges. Operation outside these ranges may adversely affect reliability and could result in device failure.

No warranty is made with respect to uses, operating conditions, or combinations not represented on the data sheet. Users considering application outside the listed conditions are advised to contact their FUJITSU representatives beforehand.

MB91F158

3. DC Characteristics

($V_{CC} = 3.2 \text{ V to } 3.5 \text{ V}$, $V_{SS} = AV_{SS} = 0 \text{ V}$, $T_A = 0 \text{ }^\circ\text{C to } +70 \text{ }^\circ\text{C}$)

Parameter	Symbol	Pin name	Condition	Value			Unit	Remarks
				Min	Typ	Max		
“H” level input voltage	V_{IH}	Input except for hysteresis input pin*	—	$0.65 \times V_{CC}$	—	$V_{CC} + 0.3$	V	
	V_{IHS}	Hysteresis input pin*	—	$0.8 \times V_{CC}$	—	$V_{CC} + 0.3$	V	
“L” level input voltage	V_{IL}	Input except for hysteresis input pin*	—	$V_{SS} - 0.3$	—	$0.25 \times V_{CC}$	V	
	V_{ILS}	Hysteresis input pin*	—	$V_{SS} - 0.3$	—	$0.2 \times V_{CC}$	V	
“H” level output voltage	V_{OH}	—	$V_{CC} = 3.2 \text{ V}$ $I_{OH} = 4.0 \text{ mA}$	$V_{CC} - 0.5$	—	—	V	
“L” level output voltage	V_{OL}	—	$V_{CC} = 3.2 \text{ V}$ $I_{OL} = 4.0 \text{ mA}$	—	—	0.4	V	
Input leakage current	I_{LI}	—	$V_{CC} = 3.5 \text{ V}$, $V_{SS} < V_I < V_{CC}$	—	—	± 5	μA	
Pullup resistance	R_{PULL}	\overline{RST} , pullup pin	—	—	50	—	$\text{k}\Omega$	
Power supply current	I_{CC}	V_{CC}	$V_{CC} = 3.3 \text{ V}$	—	85	110	mA	
	I_{CCS}	V_{CC}	$V_{CC} = 3.3 \text{ V}$	—	60	90	mA	During sleep mode
	I_{CCH}	V_{CC}	$V_{CC} = 3.3 \text{ V}$, $T_A = +25 \text{ }^\circ\text{C}$	—	15	300	μA	During stop mode
Input capacity	C_{IN}	Other than V_{CC} , V_{SS} , AV_{CC} , AV_{SS} , and $AVRH$	—	—	5	15	pF	

* : Refer to “**■** I/O CIRCUIT TYPE”.

4. Flash Memory Erase and Programming Performance

($V_{SS} = AV_{SS} = 0\text{ V}$)

Parameter	Value			Unit	Remarks
	Min	Typ	Max		
Sector Erase Time	—	1 *1	15 *2	s	Excludes programming time prior to erasure
Byte Programming Time	—	8 *1	3600 *2	μs	Excludes system-level overhead
Chip Programming Time	—	4.2 *1	—	s	Excludes system-level overhead
Erase/Program Cycle	10000	—	—	cycle	

*1 : $T_A = +25\text{ °C}$, $V_{CC} = 3.3\text{ V}$, 10,000 cycles

*2 : $T_A = +70\text{ °C}$, $V_{CC} = 3.3\text{ V}$, 10,000 cycles

MB91F158

5. AC Characteristics

(1) Clock Timing Ratings

($V_{CC} = 3.2 \text{ V to } 3.5 \text{ V}$, $V_{SS} = AV_{SS} = 0 \text{ V}$, $T_A = 0 \text{ }^\circ\text{C to } +70 \text{ }^\circ\text{C}$)

Parameter	Symbol	Pin name	Condition	Value		Unit	Remarks	
				Min	Max			
Clock frequency (High speed and self oscillation)	f _c	X0, X1	—	10	16	MHz	Range in which self oscillation is allowed	
Clock frequency (High speed and PLL in use)			—				Range in which self oscillation and the use of the PLL for external clock input are allowed	
Clock frequency (High speed an 1/2 division input)			—	10	16	MHz	Range in which external clocks can be input	
Clock cycle time	t _c	X0, X1	—	62.5	100	ns		
Clock pulse width	P _{WH}	X0, X1	—	25	—			
	P _{WL}		—	15	—			
Input clock rising	t _{cr}	X0, X1	—	—	8		(t _{cr} + t _{cf})	
Input clock falling	t _{cf}		—					
Internal operating clock frequency	CPU system	f _{CP}	—	One wait is set with the wait controller.	0.625* ³	32	MHz	
	Bus system	f _{CPB}			0.625* ³	25* ²		
	Peripheral system	f _{CPP}			0.625* ³	32		Analog section excluded. * ¹
					1	32		Analog section * ¹
Internal operating clock cycle time	CPU system	t _{CP}	—	One wait is set with the wait controller.	31.25	1600* ³	ns	
	Bus system	t _{CPB}			40* ²	1600* ³		
	Peripheral system	t _{CPP}			31.25	1600* ³		Analog section excluded. * ¹
					31.25	1000		Analog section * ¹

*1 : The target analog section is the A/D.

*2 : The maximum external bus operating frequency allowed is 25 MHz.

*3 : The value when a minimum clock frequency of 10 MHz is input to X0 and half a division of the oscillator circuit and the 1/8 gear are in use.

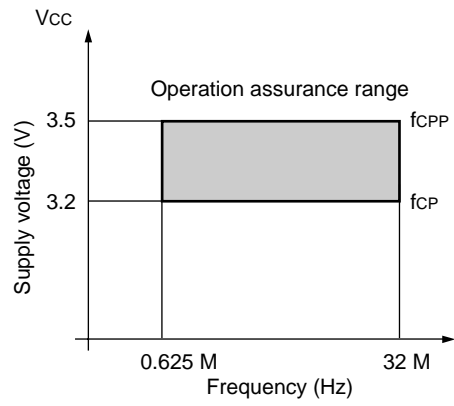
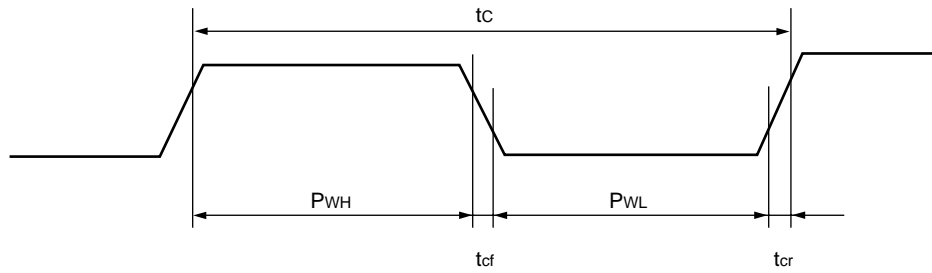

MB91F158

The relationship between the X0 input and the internal clock set with the CHC/CCK1/CCK0 bit of the GCR (Gear Control Register) is as shown next.

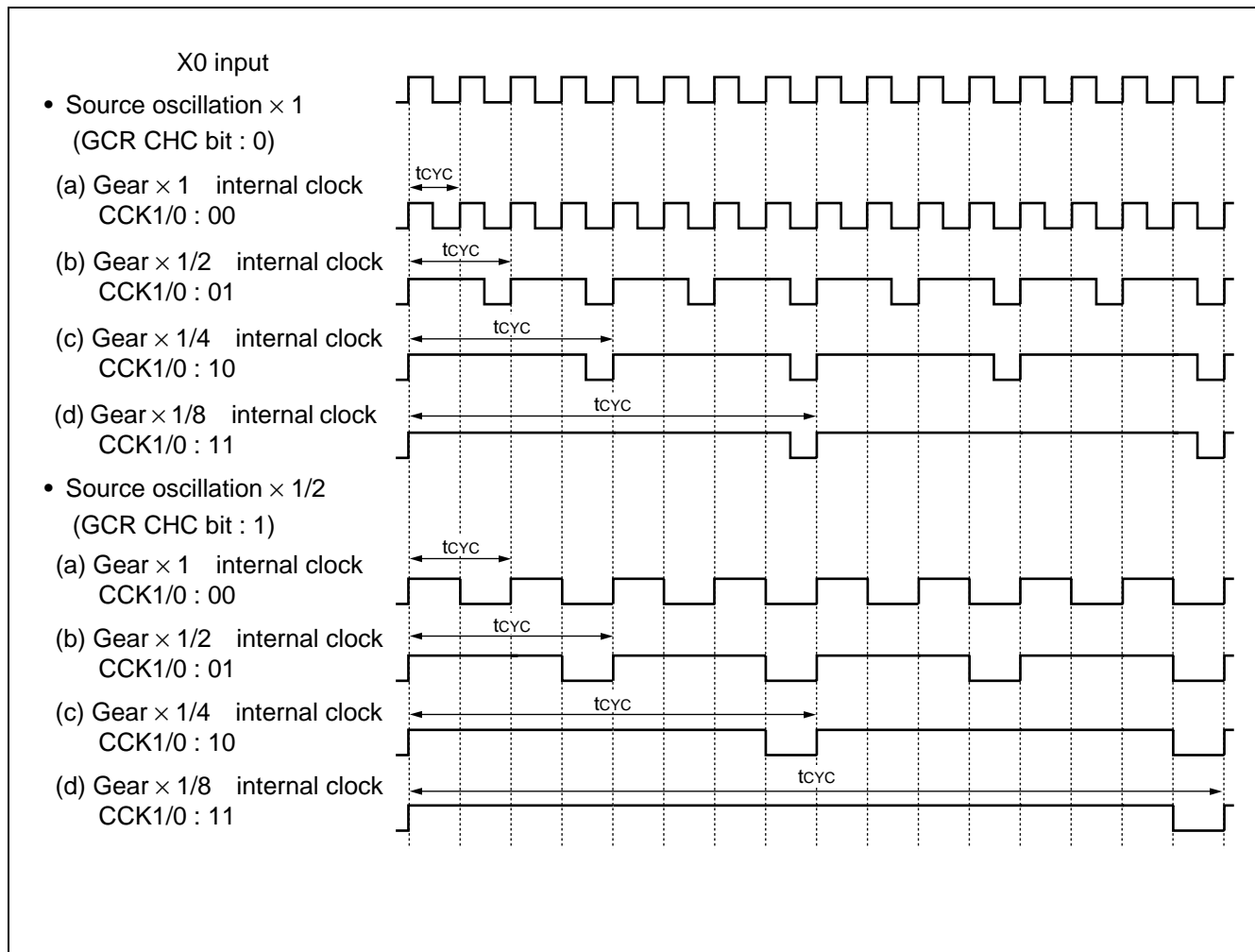

(2) Clock Output Timing

($V_{CC} = 3.2\text{ V to }3.5\text{ V}$, $V_{SS} = AV_{SS} = 0\text{ V}$, $T_A = 0\text{ }^\circ\text{C to }+70\text{ }^\circ\text{C}$)

Parameter	Symbol	Pin name	Condition	Value		Unit	Remarks
				Min	Max		
Cycle time	t_{CYC}	CLK	—	t_{CP}		ns	*1
				t_{CPB}			On using doubla
CLK \uparrow →CLK \downarrow	t_{CHCL}	CLK		$t_{CYC}/2-10$	$t_{CYC}/2+10$	ns	*2
CLK \downarrow →CLK \uparrow	t_{CLCH}	CLK		$t_{CYC}/2-10$	$t_{CYC}/2+10$	ns	*3

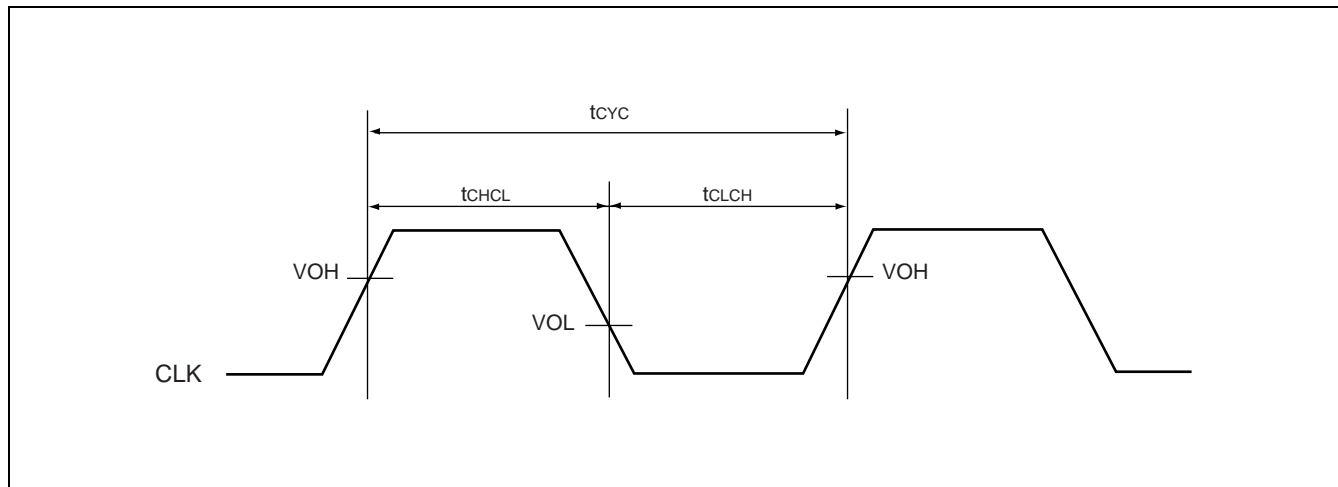

*1 : t_{CYC} is a frequency for 1clock cycle including a gear cycle.
Use the doublur when CPU frequency is above 25 MHz.

*2 : Rating at a gear cycle of $\times 1$

When a gear cycle of 1/2, 1/4, 1/8 is selected, substitute "n" in the following equations wiht 1/2, 1/4, 1/8, respectively.

- Min : $(1-n/2) \times t_{CYC}-10$
- Max : $(1-n/2) \times t_{CYC}+10$

Select a gear sycle of $\times 1$ when using the doublur.

*3 : Rating at a gear cycle of $\times 1$

When a gear cycle of 1/2, 1/4, 1/8 selected, substitute "n" in the following equations wiht 1/2, 1/4, 1/8, respectively.

- Min : $n/2 \times t_{CYC}-10$
- Max : $n/2 \times t_{CYC}+10$

Select a gear sycle of $\times 1$ when using the doublur.

MB91F158

(3) Reset Input Ratings

($V_{CC} = 3.2\text{ V to }3.5\text{ V}$, $V_{SS} = AV_{SS} = 0\text{ V}$, $T_A = 0\text{ }^\circ\text{C to }+70\text{ }^\circ\text{C}$)

Parameter	Symbol	Pin name	Condition	Value		Unit	Remarks
				Min	Max		
Reset input time	t_{RSTL}	\overline{RST}	—	$t_{CP} \times 5$	—	ns	

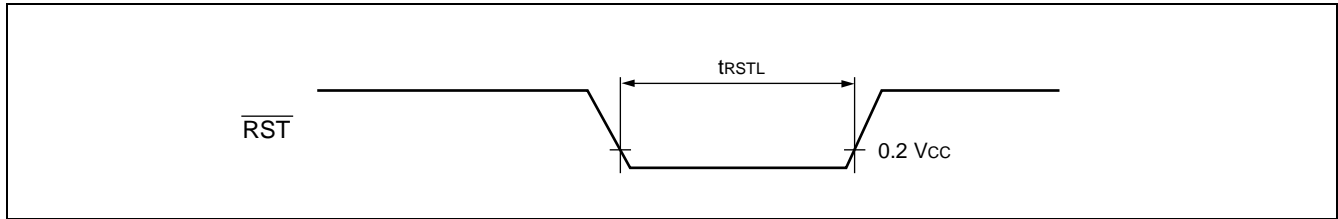

(4) Power On Reset

($V_{CC} = 3.2\text{ V to }3.5\text{ V}$, $V_{SS} = AV_{SS} = 0\text{ V}$, $T_A = 0\text{ }^\circ\text{C to }+70\text{ }^\circ\text{C}$)

Parameter	Symbol	Pin name	Condition	Value		Unit	Remarks
				Min	Max		
Power supply rising time	f_R	V_{CC}	—	—	20	ms	$V_{CC} < 0.2\text{ V}$ before turning up the power.
Power supply cutoff time	t_{OFF}			2	—	ms	

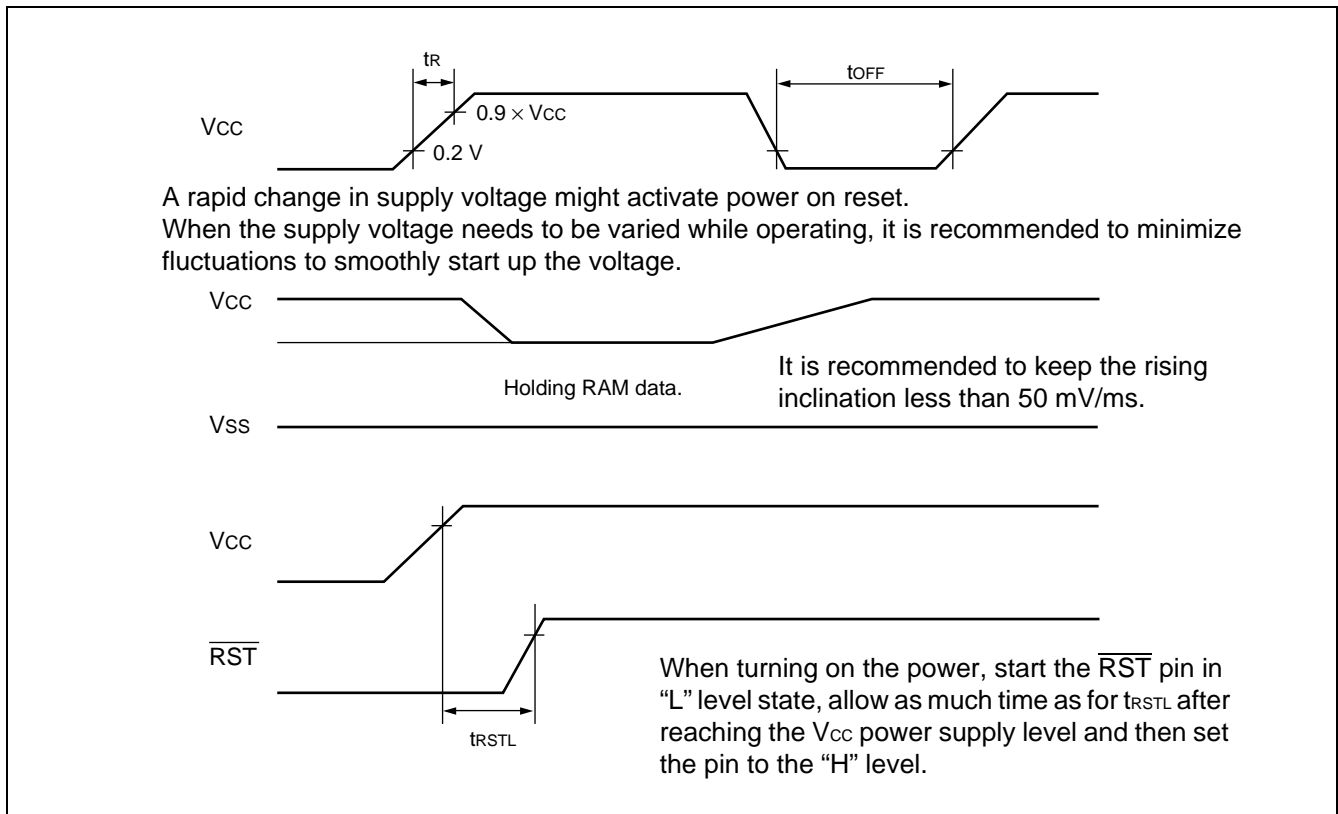

(5) Serial I/O (CH0-4)

($V_{CC} = 3.2\text{ V to }3.5\text{ V}$, $V_{SS} = AV_{SS} = 0\text{ V}$, $T_A = 0\text{ }^{\circ}\text{C to }+70\text{ }^{\circ}\text{C}$)

Parameter	Symbol	Pin name	Condition	Value		Unit	Remarks
				Min	Max		
Serial clock cycle time	t_{SCYC}	—	Internal clock	$8 t_{CPP}$	—	ns	
SCK $\downarrow \rightarrow$ SO delay time	t_{SLOV}	—		-10	50	ns	
Valid SI \rightarrow SCK \uparrow	t_{IVSH}	—		50	—	ns	
SCK $\uparrow \rightarrow$ valid SI hold time	t_{SHIX}	—		50	—	ns	
Serial clock "H" pulse width	t_{SHSL}	—	External clock	$4 t_{CPP} - 10$	—	ns	
Serial clock "L" pulse width	t_{LSLH}	—		$4 t_{CPP} - 10$	—	ns	
SCK $\downarrow \rightarrow$ SO delay time	t_{SLOV}	—		0	50	ns	
Valid SI \rightarrow SCK \uparrow	t_{IVSH}	—		50	—	ns	
SCK $\uparrow \rightarrow$ valid SI hold time	t_{SHIX}	—		50	—	ns	
Serial busy period	t_{BUSY}	—		—	$6 t_{CPP}$	ns	
SCS $\downarrow \rightarrow$ SCK and SO delay time	t_{CLZO}	—		—	50	ns	
SCS $\downarrow \rightarrow$ SCK input mask time	t_{CLSL}	—		—	$3 t_{CPP}$	ns	
SCS $\uparrow \rightarrow$ SCK and SO Hi-Z time	t_{CHOZ}	—	50	—	ns		

Internal shift clock mode

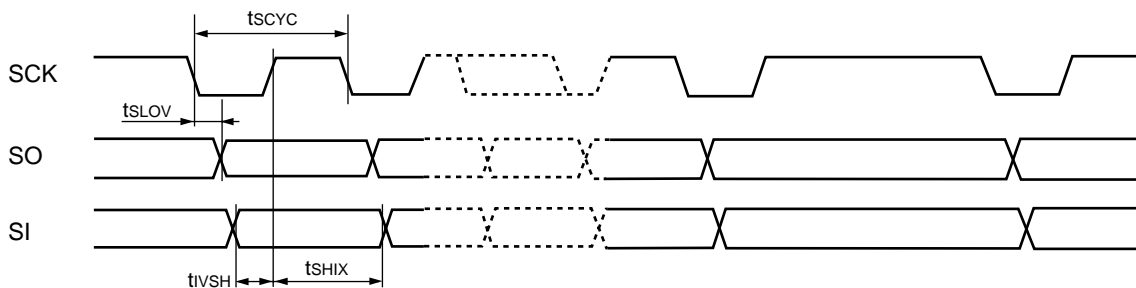

External shift clock mode

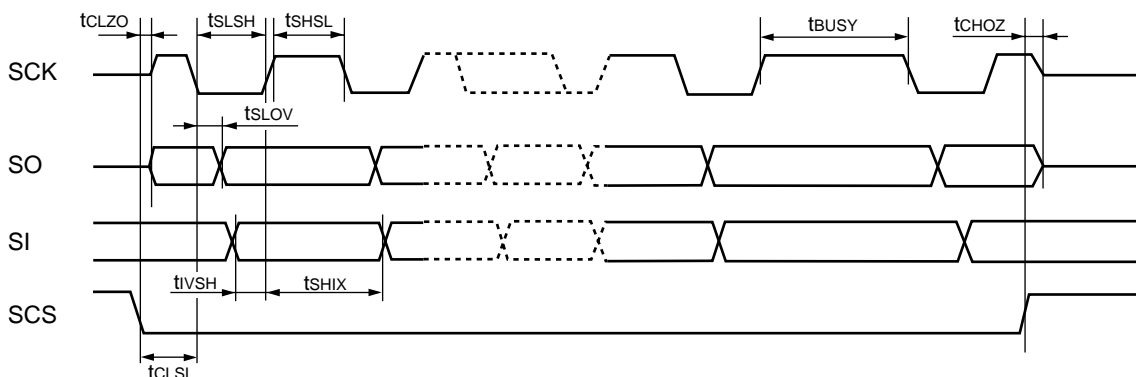

MB91F158

(6) External Bus Measurement Conditions

The following conditions apply to items that are not specifically stipulated.

- AC characteristics measurement conditions

$V_{CC} : 3.3 \text{ V}$

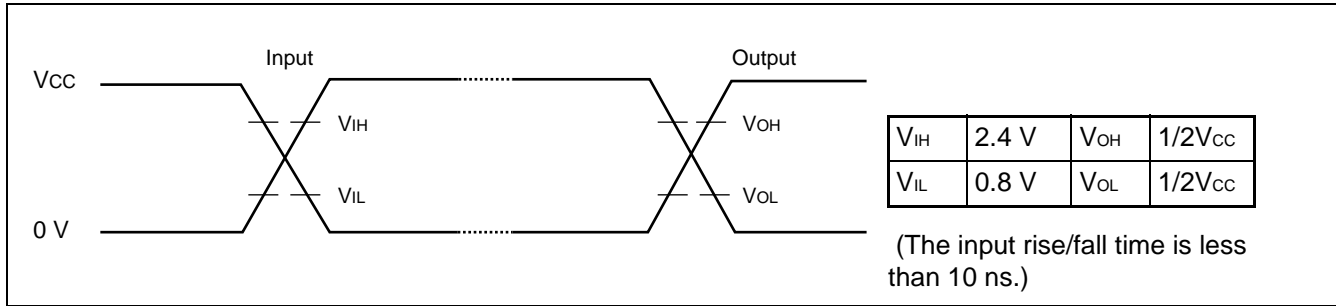

- Load condition

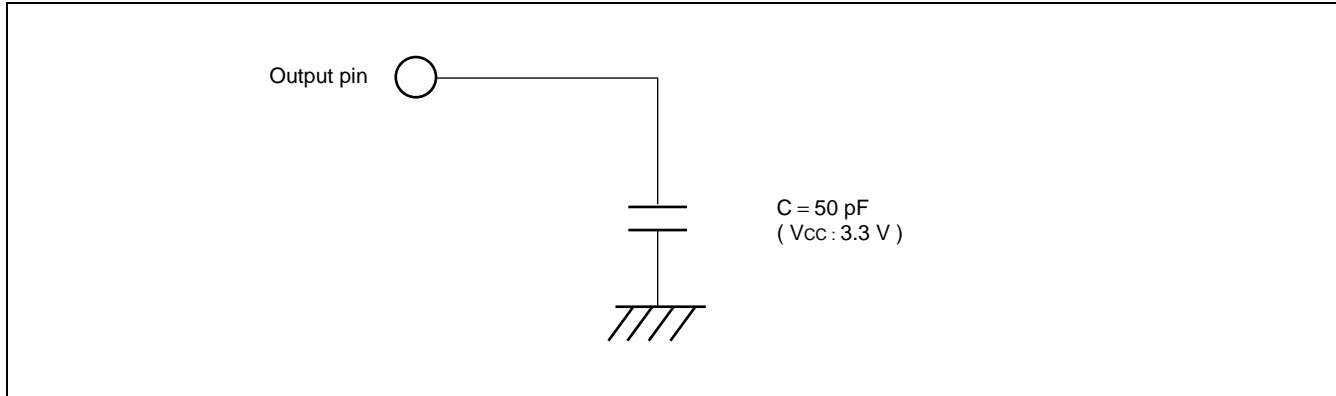

(7) Normal Bus Access and Read/Write Operations

($V_{CC} = 3.2\text{ V to }3.5\text{ V}$, $V_{SS} = AV_{SS} = 0\text{ V}$, $T_A = 0\text{ }^\circ\text{C to }+70\text{ }^\circ\text{C}$)

Parameter	Symbol	Pin name	Condition	Value		Unit	Remarks
				Min	Max		
CS0 - CS3 delay time	t_{CHCSL}	CLK, CS0 to CS3	—	—	15	ns	
CS0 - CS3 delay time	t_{CHCSH}			—	15	ns	
Address delay time	t_{CHAV}	CLK, A23 to A00		—	15	ns	
Data delay time	t_{CHDV}	CLK, D31 to D16		—	15	ns	
\overline{RD} delay time	$t_{CLR L}$	CLK, \overline{RD}		—	10	ns	
\overline{RD} delay time	$t_{CLR H}$			—	10	ns	
$\overline{WR0} - \overline{WR1}$ delay time	t_{CLWL}	CLK, $\overline{WR0}$, $\overline{WR1}$		—	10	ns	
$\overline{WR0} - \overline{WR1}$ delay time	t_{CLWH}			—	10	ns	
Valid address → valid data input time	t_{AVDV}	A23 to A00, D31 to D16		—	$3/2 \times$ $t_{CYC} - 40$	ns	*1, *2
$\overline{RD} \downarrow \rightarrow$ valid data input time	t_{RLDV}	\overline{RD} , D31 to D16		—	$t_{CYC} - 25$	ns	*1
Data setup → $\overline{RD} \uparrow$ time	t_{DSRH}		25	—	ns		
$\overline{RD} \uparrow \rightarrow$ Rdata hold time	t_{RHDX}		0	—	ns		

*1 : If the bus is extended with either automatic wait insertion or RDY input, add the ($t_{CYC} \times$ the number of extended cycles) time to this value.

*2 : This is the value at the time of (gear cycle \times 1) .

When the gear cycle is set to 1/2, 1/4 or 1/8, substitute "n" in the following formula with 1/2, 1/4 or 1/8 respectively.

$$\text{Formula : } (2 - n / 2) \times t_{CYC} - 40$$

MB91F158

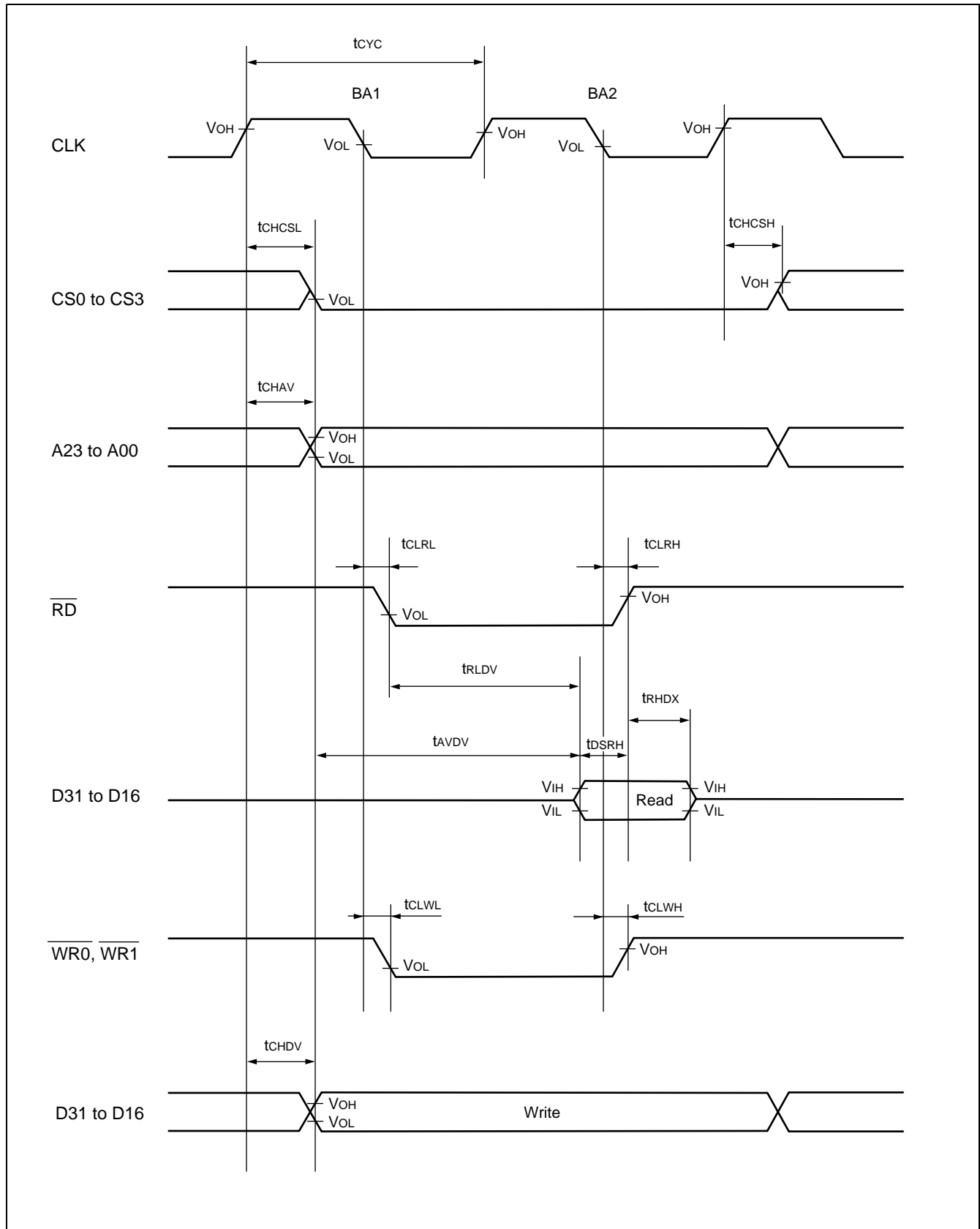

(8) Ready Input Timing

($V_{CC} = 3.2\text{ V to }3.5\text{ V}$, $V_{SS} = AV_{SS} = 0\text{ V}$, $T_A = 0\text{ }^{\circ}\text{C to }+70\text{ }^{\circ}\text{C}$)

Parameter	Symbol	Pin name	Condition	Value		Unit	Remarks
				Min	Max		
RDY setup time \rightarrow CLK \downarrow	t_{RDYS}	RDY CLK	—	20	—	ns	
CLK \downarrow \rightarrow RDY hold time	t_{RDYH}	RDY CLK		0	—	ns	

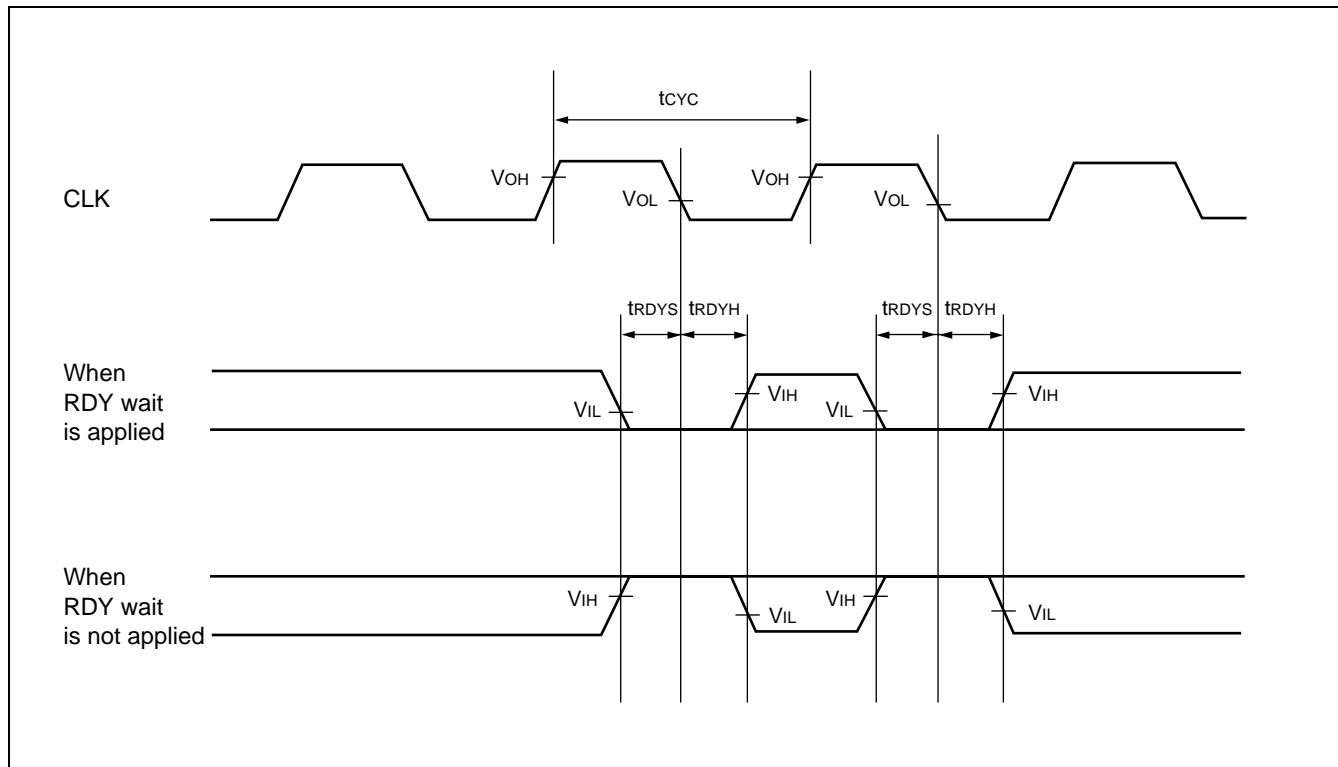

MB91F158

(9) Hold Timing

($V_{CC} = 3.2\text{ V to }3.5\text{ V}$, $V_{SS} = AV_{SS} = 0\text{ V}$, $T_A = 0\text{ }^{\circ}\text{C to }+70\text{ }^{\circ}\text{C}$)

Parameter	Symbol	Pin name	Condition	Value		Unit	Remarks
				Min	Max		
BGRNT̄ delay time	t_{CHBGL}	CLK	—	—	10	ns	
BGRNT̄ delay time	t_{CHBGH}	BGRNT̄		—	10	ns	
Pin floating → BGRNT̄ ↓ time	t_{XHAL}	BGRNT̄		$t_{CYC} - 10$	$t_{CYC} + 10$	ns	
BGRNT̄ ↑ → Pin valid time	t_{HAHV}			$t_{CYC} - 10$	$t_{CYC} + 10$	ns	

Note : More than one cycle exist after BRQ is fetched and before BGRNT̄ changes.

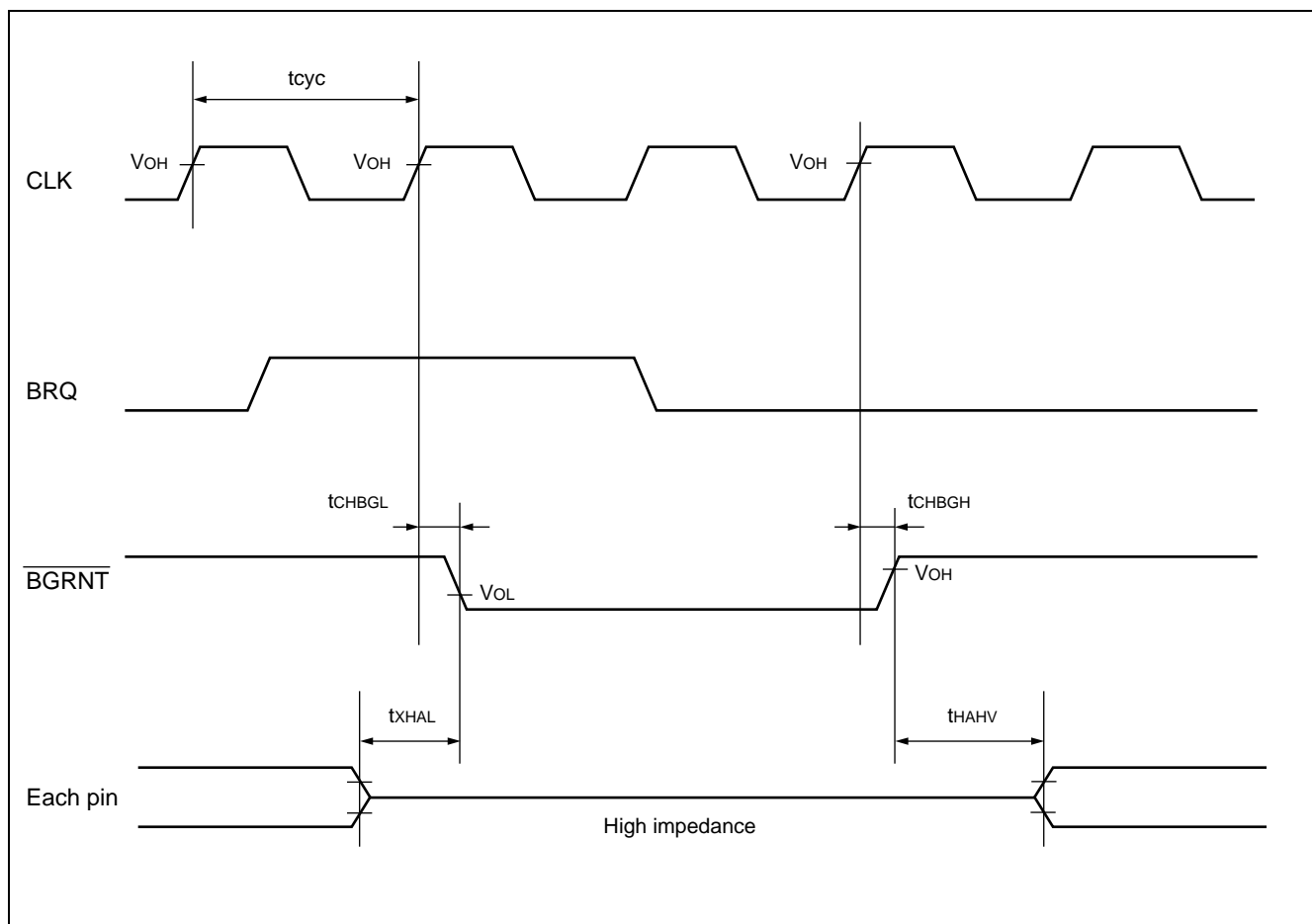

6. A/D Converter Electrical Characteristics

($V_{CC} = 3.2\text{ V to } 3.5\text{ V}$, $V_{SS} = AV_{SS} = 0\text{ V}$, $T_A = 0\text{ }^\circ\text{C to } +70\text{ }^\circ\text{C}$)

Parameter	Symbol	Pin name	Condition	Value			Unit	Remarks	
				Min	Typ	Max			
Resolution	—	—	—	—	—	10	Bit		
Conversion time	—	—		5.2	—	—	μs		
Comparison time	—	—	—	—	—	0.2	ms		
Total error	—	—	$AV_{CC} = 3.3\text{ V}$, $AV_{RH} = 3.3\text{ V}$	—	—	± 4.0	LSB		
Linearity error	—	—		—	—	± 3.5	LSB		
Differential linearity error	—	—		—	—	± 2.0	LSB		
Zero transition error	V_{OT}	AN0 to AN7	$AV_{CC} = 3.3\text{ V}$, $AV_{RH} = 3.3\text{ V}$	$AV_{SS} - 1.5$	$AV_{SS} + 0.5$	$AV_{SS} + 2.5$	LSB		
Full-scale transition error	V_{FST}	AN0 to AN7		$AV_{RH} - 5.5$	$AV_{RH} - 1.5$	$AV_{RH} + 0.5$	LSB		
Analog input current	I_{AIN}	AN0 to AN7	—	—	0.1	10	μA		
Analog input voltage	V_{AIN}	AN0 to AN7		AV_{SS}	—	AV_{RH}	V		
Reference voltage	AV_{RH}	AV_{RH}	—	—	—	AV_{CC}	V		
Supply current	Conversion in operation	I_A	AV_{CC}	$AV_{CC} = 3.3\text{ V}$	—	3.0	5.0	mA	
	Conversion stopped	I_{AH}			—	—	5.0	μA	
Reference voltage supply current	Conversion in operation	I_R	AV_{RH}	$AV_{CC} = 3.3\text{ V}$, $AV_{RH} = 3.3\text{ V}$	—	2.0	3.0	mA	
	Conversion stopped	I_{RH}			—	—	10	μA	
Interchannel variation	—	AN0 to AN7	—	—	—	4	LSB		

- Notes :
- The smaller the $|AV_{RH}|$ is, the greater the error is in general.
 - The external circuit output impedance of analog input should be used in compliance with the following requirements :
External circuit output impedance $\leq 2\text{ (k}\Omega\text{)}$
If the output impedance of the external circuit is too high, an analog voltage sampling duration shortage might occur. (Sampling duration = $1.41\text{ }\mu\text{s}$: @32 MHz)

• **A/D Converter Glossary**

- Resolution : Analog changes that are identifiable by the A/D converter.
- Linearity error : The deviation of the straight line connecting the zero transition point (00 0000 0000 \leftrightarrow 00 0000 0001) with the full-scale transition point (11 1111 1110 \leftrightarrow 11 1111 1111) from actual conversion characteristics.
- Differential linearity error : The deviation of input voltage needed to change the output code by one LSB from the theoretical value.
- Total error : The difference between actual and theoretical conversion values including a zero transition/full-scale transition/linearity error.

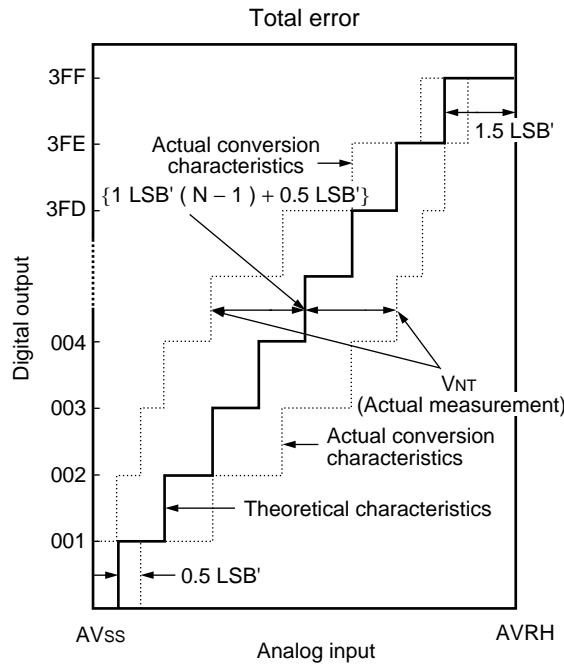

$$1 \text{ LSB}' \text{ (theoretical value)} = \frac{\text{AVRH} - \text{AV}_{\text{SS}}}{1024} \quad [\text{V}]$$

$$V_{\text{OT}}' \text{ (theoretical value)} = \text{AV}_{\text{SS}} + 0.5 \text{ LSB}' \quad [\text{V}]$$

$$V_{\text{FST}}' \text{ (theoretical value)} = \text{AVRH} - 1.5 \text{ LSB}' \quad [\text{V}]$$

$$\text{Total error of digital output } N = \frac{V_{\text{NT}} - \{1 \text{ LSB}' \times (N - 1) + 0.5 \text{ LSB}'\}}{1 \text{ LSB}'}$$

V_{NT} : Voltage at which digital output changes from (N + 1) to N.

(Continued)

(Continued)

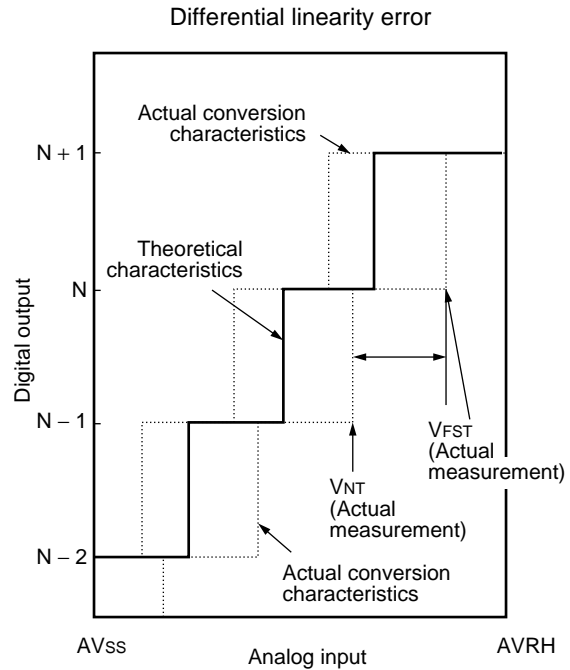
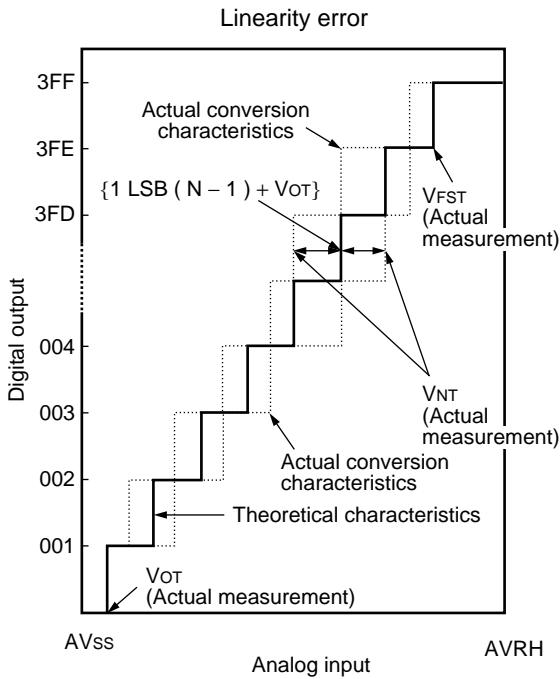

$$\text{Linearity error of digital output } N = \frac{V_{NT} - \{1 \text{ LSB} \times (N - 1) + V_{OT}\}}{1 \text{ LSB}} \quad [\text{LSB}]$$

$$\text{Differential linearity error of digital output } N = \frac{V_{(N+1)T} - V_{NT}}{1 \text{ LSB}} - 1 \quad [\text{LSB}]$$

$$1 \text{ LSB} = \frac{V_{FST} - V_{OT}}{1022} \quad [\text{V}]$$

V_{OT} : Voltage at which digital output changes from (000)_H to (001)_H.

V_{FST} : Voltage at which digital output changes from (3FE)_H to (3FF)_H.

7. D/A Converter Electrical Characteristics

($V_{CC} = 3.2 \text{ V to } 3.5 \text{ V}$, $V_{SS} = AV_{SS} = 0 \text{ V}$, $T_A = 0 \text{ }^\circ\text{C to } +70 \text{ }^\circ\text{C}$)

Parameter	Symbol	Pin name	Condition	Value			Unit	Remarks
				Min	Typ	Max		
Resolution	—	—	—	—	—	8	Bit	
Differential linearity error	—	—	—	—	—	1	LSB	
Conversion time	—	—	—	—	—	20	μs	*
Analog output impedance	—	—	—	—	29	—	$\text{k}\Omega$	

* : $CL = 20 \text{ pF}$

EXAMPLE CHARACTERISTICS

(1) "H" level output voltage

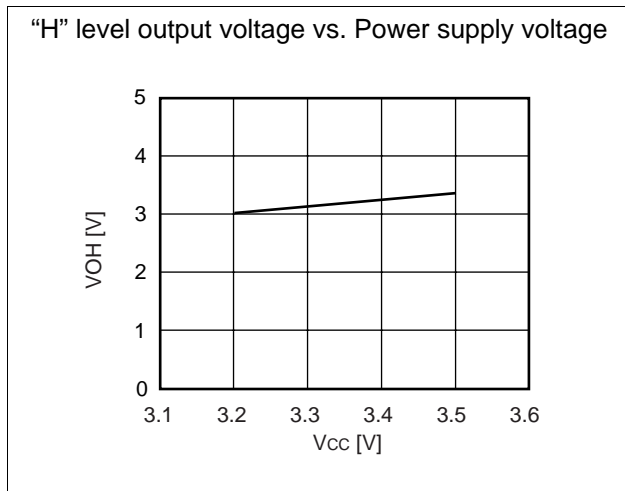

(2) "L" level output voltage

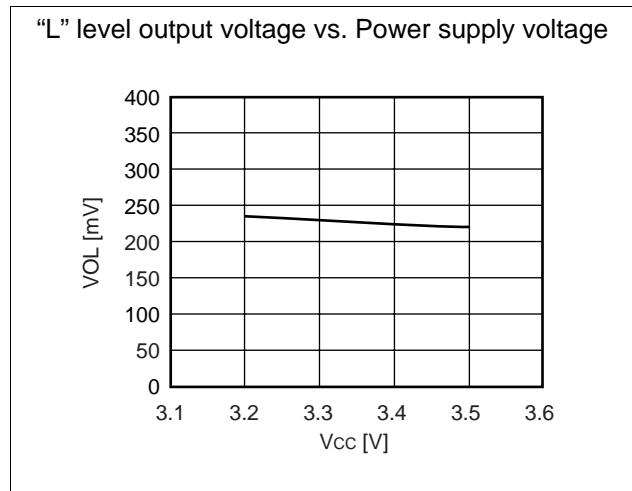

(3) Pull-up resistance

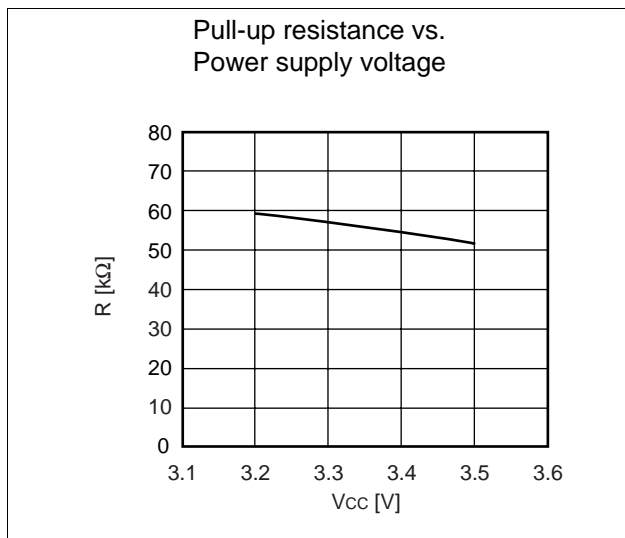

(4) Power supply current

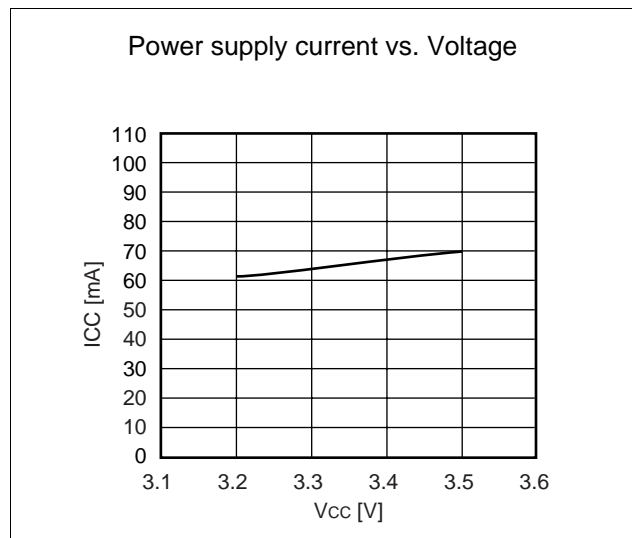

(5) Power supply at sleeping

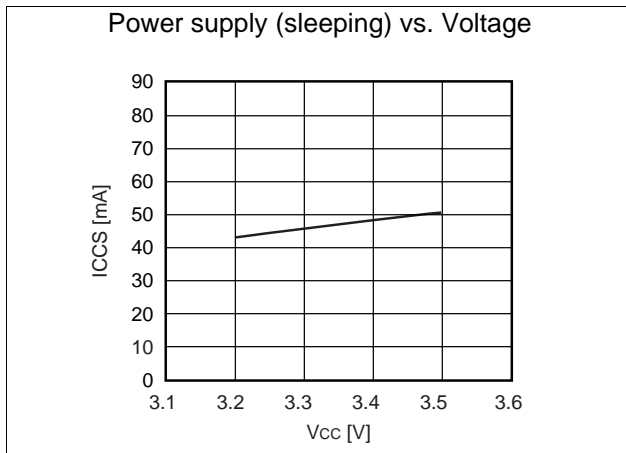

(6) Power supply at stopping

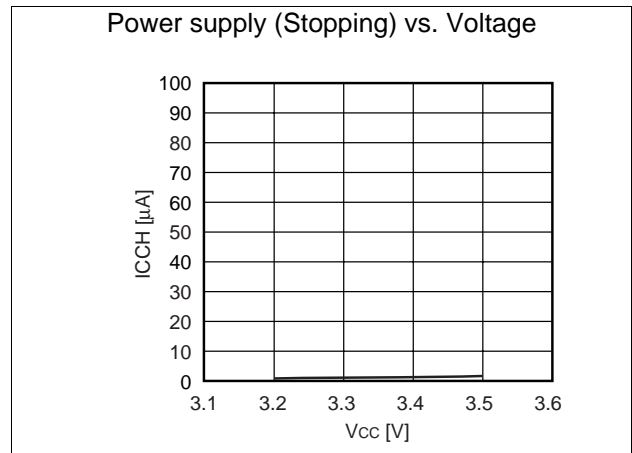

(7) A/D conversion power supply (32 MHz)

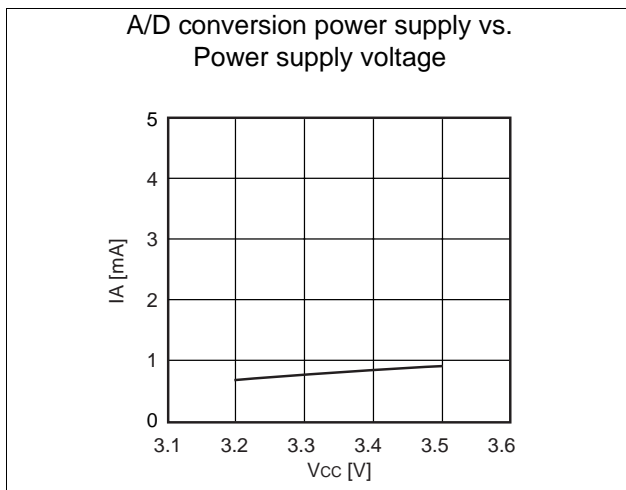

(8) A/D conversion reference voltage supply current (32 MHz)

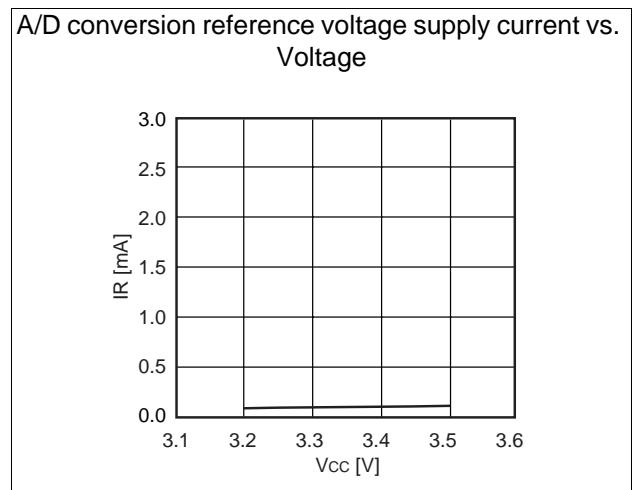

(9) A/D conversion reference voltage supply current per 1 ch (32 MHz)

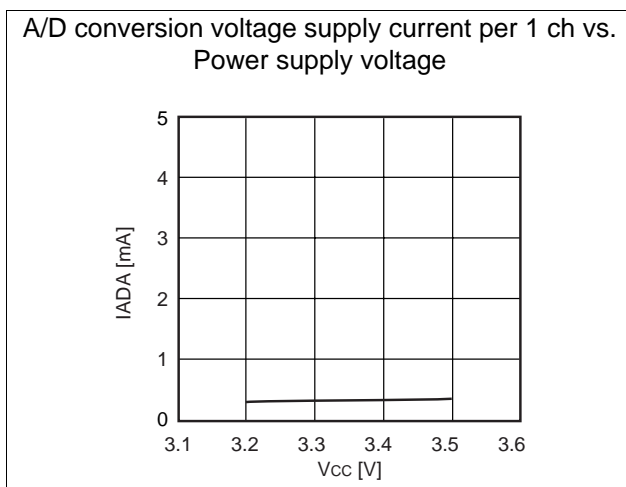

MB91F158

■ ORDERING INFORMATION

Part number	Package	Remarks
MB91F158PFF-G	120-pin plastic LQFP (FPT-120P-M05)	

■ PACKAGE DIMENSION

120-pin plastic LQFP
(FPT-120P-M05)

Note 1) * : These dimensions do not include resin protrusion.
Note 2) Pins width and pins thickness include plating thickness.
Note 3) Pins width do not include tie bar cutting remainder.

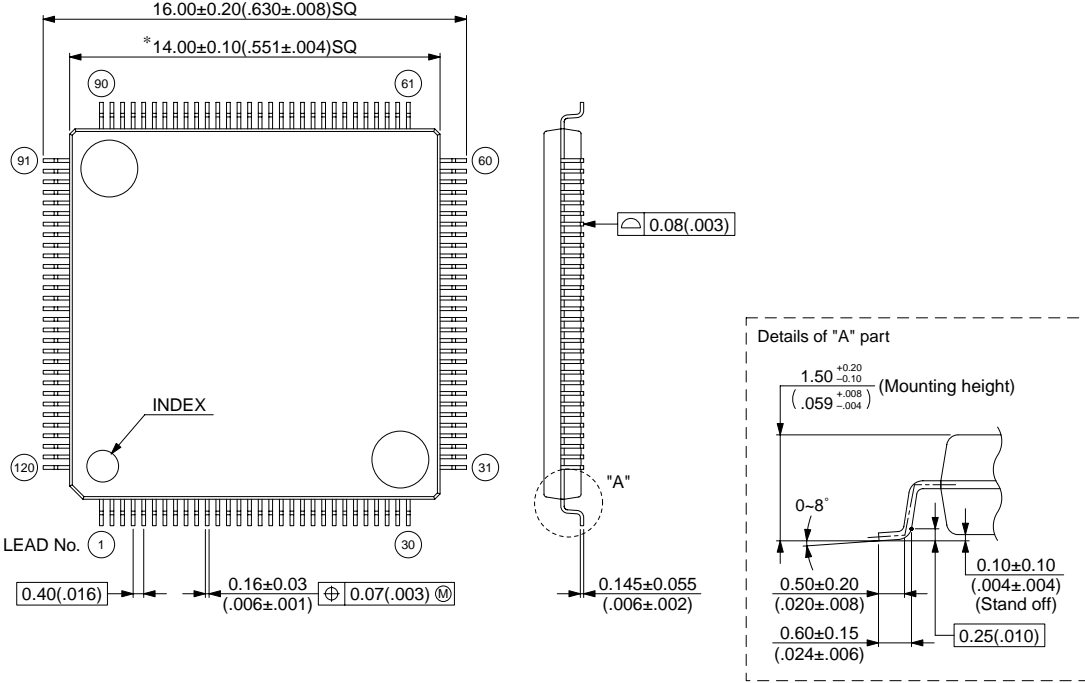

© 2003 FUJITSU LIMITED F120006S-c-4-5

Dimensions in mm (inches)
Note: The values in parentheses are reference values.

FUJITSU LIMITED

All Rights Reserved.

The contents of this document are subject to change without notice. Customers are advised to consult with FUJITSU sales representatives before ordering.

The information, such as descriptions of function and application circuit examples, in this document are presented solely for the purpose of reference to show examples of operations and uses of Fujitsu semiconductor device; Fujitsu does not warrant proper operation of the device with respect to use based on such information. When you develop equipment incorporating the device based on such information, you must assume any responsibility arising out of such use of the information. Fujitsu assumes no liability for any damages whatsoever arising out of the use of the information.

Any information in this document, including descriptions of function and schematic diagrams, shall not be construed as license of the use or exercise of any intellectual property right, such as patent right or copyright, or any other right of Fujitsu or any third party or does Fujitsu warrant non-infringement of any third-party's intellectual property right or other right by using such information. Fujitsu assumes no liability for any infringement of the intellectual property rights or other rights of third parties which would result from the use of information contained herein.

The products described in this document are designed, developed and manufactured as contemplated for general use, including without limitation, ordinary industrial use, general office use, personal use, and household use, but are not designed, developed and manufactured as contemplated (1) for use accompanying fatal risks or dangers that, unless extremely high safety is secured, could have a serious effect to the public, and could lead directly to death, personal injury, severe physical damage or other loss (i.e., nuclear reaction control in nuclear facility, aircraft flight control, air traffic control, mass transport control, medical life support system, missile launch control in weapon system), or (2) for use requiring extremely high reliability (i.e., submersible repeater and artificial satellite).

Please note that Fujitsu will not be liable against you and/or any third party for any claims or damages arising in connection with above-mentioned uses of the products.

Any semiconductor devices have an inherent chance of failure. You must protect against injury, damage or loss from such failures by incorporating safety design measures into your facility and equipment such as redundancy, fire protection, and prevention of over-current levels and other abnormal operating conditions.

If any products described in this document represent goods or technologies subject to certain restrictions on export under the Foreign Exchange and Foreign Trade Law of Japan, the prior authorization by Japanese government will be required for export of those products from Japan.