



DS26324

3.3V, 16-Channel, E1/T1/J1 Short-Haul Line Interface Unit

GENERAL DESCRIPTION

The DS26324 is a 16-channel short-haul line interface unit (LIU) that supports E1/T1/J1 from a single 3.3V power supply. A wide variety of applications are supported through internal impedance matching. A single bill of material can support E1/T1/J1 that requires no external termination. Redundancy is supported through nonintrusive monitoring, optimal high-impedance modes and configurable 1:1 or 1+1 backup enhancements. An on-chip synthesizer generates the E1/T1/J1 clock rates by a single master clock input of various frequencies. Two clock output references are also offered. The device is offered in a 256-pin TE-CSBGA, the smallest package available for a 16-channel LIU.

APPLICATIONS

T1 Digital Cross-Connects
 ATM and Frame Relay Equipment
 Wireless Base Stations
 ISDN Primary Rate Interface
 E1/T1/J1 Multiplexer and Channel Banks
 E1/T1/J1 LAN/WAN Routers

FUNCTIONAL DIAGRAM

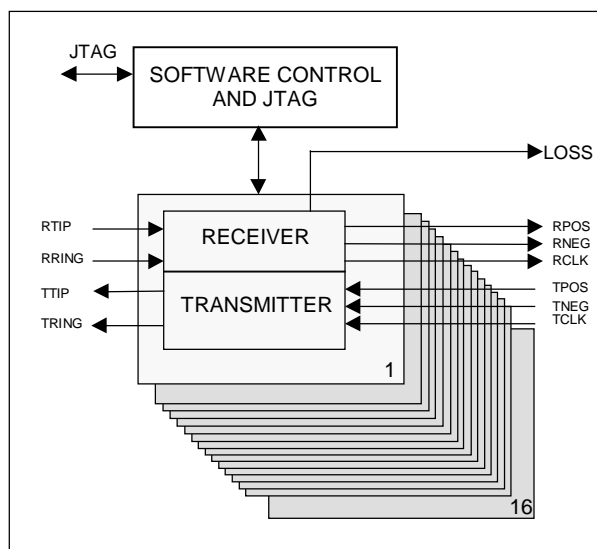

FEATURES

- 16 E1, T1, or J1 Short-Haul Line Interface Units
- Independent E1, T1 or J1 Selections
- Fully Internal Impedance Match Requires No External Resistors
- Software-Selectable Transmit and Receive-Side Impedance Match
- Crystal-Less Jitter Attenuator
- Selectable Single-Rail and Dual-Rail Mode and AMI or HDB3/B8ZS Line Encoding and Decoding
- Detection and Generation of AIS
- Digital/Analog Loss of Signal Detection as per T1.231, G.775 and ETS 300 233
- External Master Clock Can Be Multiple of 2.048MHz or 1.544MHz for T1/J1 or E1 Operation; This Clock Will Be Internally Adapted for T1 or E1 Usage
- Receiver Signal Level Indicator from -2.5dB to -20dB in 2.5dB Increments
- Two Built-In BERT Testers for Diagnostics
- 8-Bit Parallel Interface Support for Intel or Motorola Mode or a 4-Wire Serial Interface
- Transmit Short-Circuit Protection
- G.772 Nonintrusive Monitoring
- Receive Monitor Mode Handles Combinations of 14dB to 20dB of Resistive Attenuation Along with 12dB to 30dB of Cable Attenuation
- Specification Compliance to the Latest T1 and E1 Standards
- Single 3.3V Supply with 5V Tolerant I/O
- JTAG Boundary Scan as Per IEEE 1149.1

ORDERING INFORMATION

PART	TEMP RANGE	PIN-PACKAGE
DS26324G+	0°C to +70°C	256 TE-CSBGA
DS26324GN+	-40°C to +85°C	256 TE-CSBGA
DS26324G	0°C to +70°C	256 TE-CSBGA
DS26324GN	-40°C to +85°C	256 TE-CSBGA

+Denotes a lead(Pb)-free/RoHS compliant package.

Note: Some revisions of this device may incorporate deviations from published specifications known as errata. Multiple revisions of any device may be simultaneously available through various sales channels. For information about device errata, click here: www.maxim-ic.com/errata.

TABLE OF CONTENTS

1	STANDARDS COMPLIANCE	6
1.1	TELECOM SPECIFICATIONS COMPLIANCE	6
2	DETAILED DESCRIPTION	7
3	BLOCK DIAGRAMS	8
4	PIN DESCRIPTION	10
5	FUNCTIONAL DESCRIPTION	17
5.1	PORT OPERATION	17
5.1.1	<i>Serial Port Operation</i>	<i>17</i>
5.1.2	<i>Parallel Port Operation.....</i>	<i>18</i>
5.1.3	<i>Interrupt Handling</i>	<i>18</i>
5.2	POWER-UP AND RESET	19
5.3	MASTER CLOCK	19
5.4	TRANSMITTER	20
5.4.1	<i>Transmit Line Templates.....</i>	<i>22</i>
5.4.2	<i>LIU Transmit Front-End.....</i>	<i>25</i>
5.4.3	<i>Transmit Dual-Rail Mode</i>	<i>26</i>
5.4.4	<i>Transmit Single-Rail Mode.....</i>	<i>26</i>
5.4.5	<i>Zero Suppression—B8ZS or HDB3.....</i>	<i>26</i>
5.4.6	<i>Transmit Power-Down.....</i>	<i>26</i>
5.4.7	<i>Transmit All Ones</i>	<i>27</i>
5.4.8	<i>Driver Fail Monitor.....</i>	<i>27</i>
5.5	RECEIVER.....	27
5.5.1	<i>Receiver Impedance Matching Calibration</i>	<i>27</i>
5.5.2	<i>Receiver Monitor Mode.....</i>	<i>27</i>
5.5.3	<i>Peak Detector and Slicer</i>	<i>28</i>
5.5.4	<i>Receive Level Indicator.....</i>	<i>28</i>
5.5.5	<i>Clock and Data Recovery.....</i>	<i>28</i>
5.5.6	<i>Loss of Signal.....</i>	<i>28</i>
5.5.7	<i>AIS.....</i>	<i>29</i>
5.5.8	<i>Receive Dual-Rail Mode</i>	<i>29</i>
5.5.9	<i>Receive Single-Rail Mode.....</i>	<i>30</i>
5.5.10	<i>Bipolar Violation and Excessive Zero Detector</i>	<i>30</i>
5.6	JITTER ATTENUATOR	31
5.7	G.772 MONITOR	32
5.8	LOOPBACKS.....	32
5.8.1	<i>Analog Loopback.....</i>	<i>32</i>
5.8.2	<i>Digital Loopback</i>	<i>33</i>
5.8.3	<i>Remote Loopback.....</i>	<i>33</i>
5.9	BERT.....	34
5.9.1	<i>General Description</i>	<i>34</i>
5.9.2	<i>Configuration and Monitoring</i>	<i>35</i>
5.9.3	<i>Receive Pattern Detection.....</i>	<i>36</i>
5.9.4	<i>Transmit Pattern Generation</i>	<i>38</i>
6	REGISTER MAPS AND DEFINITION	39
6.1	REGISTER DESCRIPTION.....	48
6.1.1	<i>Primary Register Bank.....</i>	<i>48</i>
6.1.2	<i>Secondary Register Bank.....</i>	<i>63</i>
6.1.3	<i>Individual LIU Register Bank.....</i>	<i>66</i>
6.1.4	<i>BERT Registers.....</i>	<i>84</i>
7	JTAG BOUNDARY SCAN ARCHITECTURE AND TEST ACCESS PORT.....	91
7.1	TAP CONTROLLER STATE MACHINE	92
7.1.1	<i>Test-Logic-Reset</i>	<i>92</i>
7.1.2	<i>Run-Test-Idle.....</i>	<i>92</i>

7.1.3	Select-DR-Scan.....	92
7.1.4	Capture-DR.....	92
7.1.5	Shift-DR.....	92
7.1.6	Exit1-DR.....	92
7.1.7	Pause-DR.....	92
7.1.8	Exit2-DR.....	92
7.1.9	Update-DR.....	92
7.1.10	Select-IR-Scan.....	93
7.1.11	Capture-IR.....	93
7.1.12	Shift-IR.....	93
7.1.13	Exit1-IR.....	93
7.1.14	Pause-IR.....	93
7.1.15	Exit2-IR.....	93
7.1.16	Update-IR.....	93
7.2	INSTRUCTION REGISTER.....	95
7.2.1	EXTEST.....	95
7.2.2	HIGHZ.....	95
7.2.3	CLAMP.....	95
7.2.4	SAMPLE/PRELOAD.....	95
7.2.5	IDCODE.....	95
7.2.6	BYPASS.....	95
7.3	TEST REGISTERS.....	96
7.3.1	Boundary Scan Register.....	96
7.3.2	Bypass Register.....	96
7.3.3	Identification Register.....	96
8	DC ELECTRICAL CHARACTERIZATION.....	97
8.1	DC PIN LOGIC LEVELS.....	97
8.2	SUPPLY CURRENT AND OUTPUT VOLTAGE.....	97
9	AC TIMING CHARACTERISTICS.....	98
9.1	LINE INTERFACE CHARACTERISTICS.....	98
9.2	PARALLEL HOST INTERFACE TIMING CHARACTERISTICS.....	99
9.3	SERIAL PORT.....	111
9.4	SYSTEM TIMING.....	112
9.5	JTAG TIMING.....	114
10	PIN CONFIGURATION.....	115
11	PACKAGE INFORMATION.....	116
12	THERMAL INFORMATION.....	117
13	DATA SHEET REVISION HISTORY.....	119

LIST OF FIGURES

Figure 3-1. Block Diagram	8
Figure 3-2. Receive Logic Detail	9
Figure 3-3. Transmit Logic Detail	9
Figure 5-1. Serial Port Operation for Write Access	17
Figure 5-2. Serial Port Operation for Read Access with CLKE = 0	17
Figure 5-3. Serial Port Operation for Read Access with CLKE = 1	18
Figure 5-4. Interrupt Handling Flow Diagram	19
Figure 5-5. Prescaler PLL and Clock Generator	20
Figure 5-6. T1 Transmit Pulse Templates.....	23
Figure 5-7. E1 Transmit Pulse Templates.....	24
Figure 5-8. LIU Front-End	25
Figure 5-9. Jitter Attenuation	31
Figure 5-10. Analog Loopback	32
Figure 5-11. Digital Loopback	33
Figure 5-12. Remote Loopback.....	33
Figure 5-13. PRBS Synchronization State Diagram.....	36
Figure 5-14. Repetitive Pattern Synchronization State Diagram.....	37
Figure 7-1. JTAG Functional Block Diagram.....	91
Figure 7-2. TAP Controller State Diagram	94
Figure 9-1. Intel Nonmuxed Read Cycle.....	100
Figure 9-2. Intel Mux Read Cycle.....	101
Figure 9-3. Intel Nonmux Write Cycle.....	103
Figure 9-4. Intel Mux Write Cycle	104
Figure 9-5. Motorola Nonmux Read Cycle.....	106
Figure 9-6. Motorola Mux Read Cycle.....	107
Figure 9-7. Motorola Nonmux Write Cycle.....	109
Figure 9-8. Motorola Mux Write Cycle	110
Figure 9-9. Serial Bus Timing Write Operation.....	111
Figure 9-10. Serial Bus Timing Read Operation with CLKE = 0	111
Figure 9-11. Serial Bus Timing Read Operation with CLKE = 1	111
Figure 9-12. Transmitter Systems Timing.....	112
Figure 9-13. Receiver Systems Timing.....	113
Figure 9-14. JTAG Timing.....	114
Figure 10-1. 256-Ball TE-CSBGA.....	115

LIST OF TABLES

Table 4-1. Pin Descriptions	10
Table 5-1. Parallel Port Mode Selection and Pin Functions.....	18
Table 5-2. Telecommunications Specification Compliance for DS26324 Transmitters.....	21
Table 5-3. Registers Related to Control of DS26324 Transmitters.....	21
Table 5-4. Template Selections for Short-Haul Mode.....	22
Table 5-6. LIU Front-End Values.....	26
Table 5-7. Loss Criteria ANSI T1.231, ITU-T G.775, and ETS 300 233 Specifications	28
Table 5-8. AIS Criteria ANSI T1.231, ITU-T G.775, and ETS 300 233 Specifications.....	29
Table 5-9. AIS Detection and Reset Criteria for DS26324.....	29
Table 5-10. Registers Related to AIS Detection.....	29
Table 5-11. BPV, Code Violation, and Excessive Zero Error Reporting.....	30
Table 5-12. Pseudorandom Pattern Generation	35
Table 5-13. Repetitive Pattern Generation.....	35
Table 6-1. Primary Register Set	40
Table 6-2. Secondary Register Set.....	41
Table 6-3. Individual LIU Register Set.....	42
Table 6-4. BERT Register Set.....	43
Table 6-5. Primary Register Set Bit Map	44
Table 6-6. Secondary Register Set Bit Map.....	45
Table 6-7. Individual LIU Register Set Bit Map	46
Table 6-8. BERT Register Bit Map	47
Table 6-9. G.772 Monitoring Control (LIU 1).....	54
Table 6-10. G.772 Monitoring Control (LIU 9).....	54
Table 6-11. TST Template Select Transmitter Register (LIUs 1–8).....	59
Table 6-12. TST Template Select Transmitter Register (LIUs 9–16).....	59
Table 6-13. Template Selection.....	60
Table 6-14. Address Pointer Bank Selection	63
Table 6-15. DS26324 MCLK Selections	69
Table 6-16. Receiver Sensitivity/Monitor Mode Gain Selection	73
Table 6-17. Receiver Signal Level.....	75
Table 6-18. Bit Error Rate Transceiver Select for Channels 1–8	79
Table 6-19. Bit Error Rate Transceiver Select for Channels 9–16	79
Table 6-20. PLL Clock Select.....	82
Table 6-21. Clock A Select.....	82
Table 7-1. Instruction Codes for IEEE 1149.1 Architecture	95
Table 7-2. ID Code Structure	96
Table 7-3. Device ID Codes	96
Table 8-1. Recommended DC Operating Conditions	97
Table 8-2. Pin Capacitance.....	97
Table 8-3. DC Characteristics	97
Table 9-1. Transmitter Characteristics.....	98
Table 9-2. Receiver Characteristics.....	98
Table 9-3. Intel Read Mode Characteristics.....	99
Table 9-4. Intel Write Cycle Characteristics.....	102
Table 9-5. Motorola Read Cycle Characteristics.....	105
Table 9-6. Motorola Write Cycle Characteristics	108
Table 9-7. Serial Port Timing Characteristics.....	111
Table 9-8. Transmitter System Timing.....	112
Table 9-9. Receiver System Timing.....	113
Table 9-10. JTAG Timing Characteristics	114
Table 12-1. Thermal Characteristics.....	117
Table 12-2. Package Power Dissipation (for Thermal Considerations).....	117
Table 12-3. Per-Channel Power-Down Savings (for Thermal Considerations).....	118

1 STANDARDS COMPLIANCE

1.1 Telecom Specifications compliance

The DS26324 LIU meets all the relevant latest Telecommunications Specifications. The following provides the T1 and E1 Specifications and relevant sections that are applicable to the DS26324.

- **T1-Related Telecommunications Specifications**
 - ANSI T1.102: Digital Hierarchy Electrical Interface
 - ANSI T1.231: Digital Hierarchy- Layer 1 in Service Performance Monitoring
 - ANSI T1.403: Network and Customer Installation Interface- DS1 Electrical Interface
 - G.736: Characteristics of a synchronous digital multiplex equipment operating at 2048kbps
 - G.823: The control of jitter and wander within digital networks which are based on the 2048kbps hierarchy
 - Pub 62411: High Capacity Terrestrial Digital Service
 - ITU-T G.772: Protected monitoring points provided on digital transmission systems

- **E1-Related Telecommunications Specifications**
 - ITU-T G.703: Physical/Electrical Characteristics of G.703 Hierarchical Digital Interfaces
 - ITU-T G.736: Characteristics of Synchronous Digital Multiplex Equipment operating at 2048kbps
 - ITU-T G.742: Second Order Digital Multiplex Equipment Operating at 8448kbps
 - ITU-T G.772: Protected monitoring points provided on digital transmission systems
 - ITU-T G.775: Loss of signal (LOS) and alarm indication signal (AIS) defect detection and clearance criteria
 - ETS 300 166: Physical and electrical characteristics of hierarchical digital interfaces for equipment using the 2048kbps-based plesiosynchronous or synchronous digital hierarchies
 - ETS 300 233: Integrated Services Digital Network (ISDN)
 - G.736: Characteristics of a synchronous digital multiplex equipment operating at 2048kbps
 - G.823: The control of jitter and wander within digital networks which are based on the 2048kbps hierarchy
 - Pub 62411: High Capacity Terrestrial Digital Service

2 DETAILED DESCRIPTION

The DS26324 is a single-chip, 16-channel, short-haul line interface unit for T1 (1.544Mbps) and E1 (2.048Mbps) applications. Sixteen independent receivers and transmitters are provided in a single TE-CSBGA package. The LIUs can be individually selected for T1, J1, or E1 operation. The LIU requires a single master reference clock. This clock can be either 1.544MHz or 2.048MHz or multiples thereof, and either frequency can be internally adapted for T1, J1, or E1 mode. Internal impedance matching provided for both transmit and receive paths reduces external component count. The transmit waveforms are compliant to G.703 and T1.102 specification. The DS26324 provides software-selectable internal transmit termination for 100 Ω T1 twisted pair, 110 Ω J1 twisted pair, 120 Ω E1 twisted pair, and 75 Ω E1 coaxial applications. The transmitters have fast high-impedance capability and can be individually powered down.

The receivers can function with up to an 18dB receive signal attenuation. A monitor gain setting also can be enabled to provide 14dB and 20dB. The DS26324 can be configured as a 14-channel LIU with Channel 1 and 9 used for nonintrusive monitoring in accordance with G.772. The receivers and transmitters can be programmed into single or dual-rail mode. AMI or HDB3/B8ZS encoding and decoding is selectable in single-rail mode. A 128-bit crystal-less on-board jitter attenuator for each LIU can be placed in receive or transmit directions. The jitter attenuator meets the ETS CTR12/13 ITU-T G.736, G.742, G.823, and AT&T Pub 62411 specifications.

The DS26324 detects and generates AIS in accordance with T1.231, G.775, and ETS 300 233. Loss of signal is detected in accordance with T1.231, G.775, and ETS 300 233. The DS26324 can perform digital, analog, remote, and dual loopbacks on individual LIUs. JTAG boundary scan is provided for the digital pins.

The DS26324 can be configured using 8-bit multiplexed or nonmultiplexed Intel or Motorola ports. A 4-pin serial port selection is also available for configuration and monitoring of the device.

The analog AMI/HDB3 waveform of the E1 line or the AMI/B8ZS waveform of the T1 line is transformer coupled into the RTIP and RRING pins of the DS26324. The user can terminate the receive line using only internal termination that requires no external resistors. Or, the user has the option to use partially internal impedance matching using a common 120 Ω external resistor for E1, T1, and J1, and matching the line impedance internally to obtain 75 Ω , 100 Ω , 110 Ω , or 120 Ω termination values. Note that fully internal impedance match requires a 1:1 transformer on the receive line. Partially internal impedance matching supports either a 1:1 or a 1:2 transformer on the receive line. If a 1:2 transformer is used, the external termination resistor should be 30 Ω . The DS26324 drives the E1 or T1 line from the TTIP and TRING pins by a 1:2 coupling transformer.

The device recovers clock and data from the analog signal and passes it through a selectable jitter attenuator outputting the received line clock at RCLK and data at RPOS and RNEG.

The DS26324 receivers can recover data and clock for up to 18dB of attenuation of the transmitted signals in T1 mode and 43dB for E1 mode. Receiver 1 can monitor the performance of receivers 2 to 8 or transmitters 2 to 8. Receiver 9 can monitor the performance of receivers 10 to 16 or transmitters 10 to 16.

The DS26324 contains 16 identical transmitters. Digital transmit data is input at TPOS/TNEG with reference to TCLK. The data at these pins can be single-rail or dual-rail. This data is processed by waveshaping circuitry and the line driver to output at TTIP and TRING in accordance with ANSI T1.102 for T1/J1 or G.703 for E1 mask.

3 BLOCK DIAGRAMS

Figure 3-1. Block Diagram

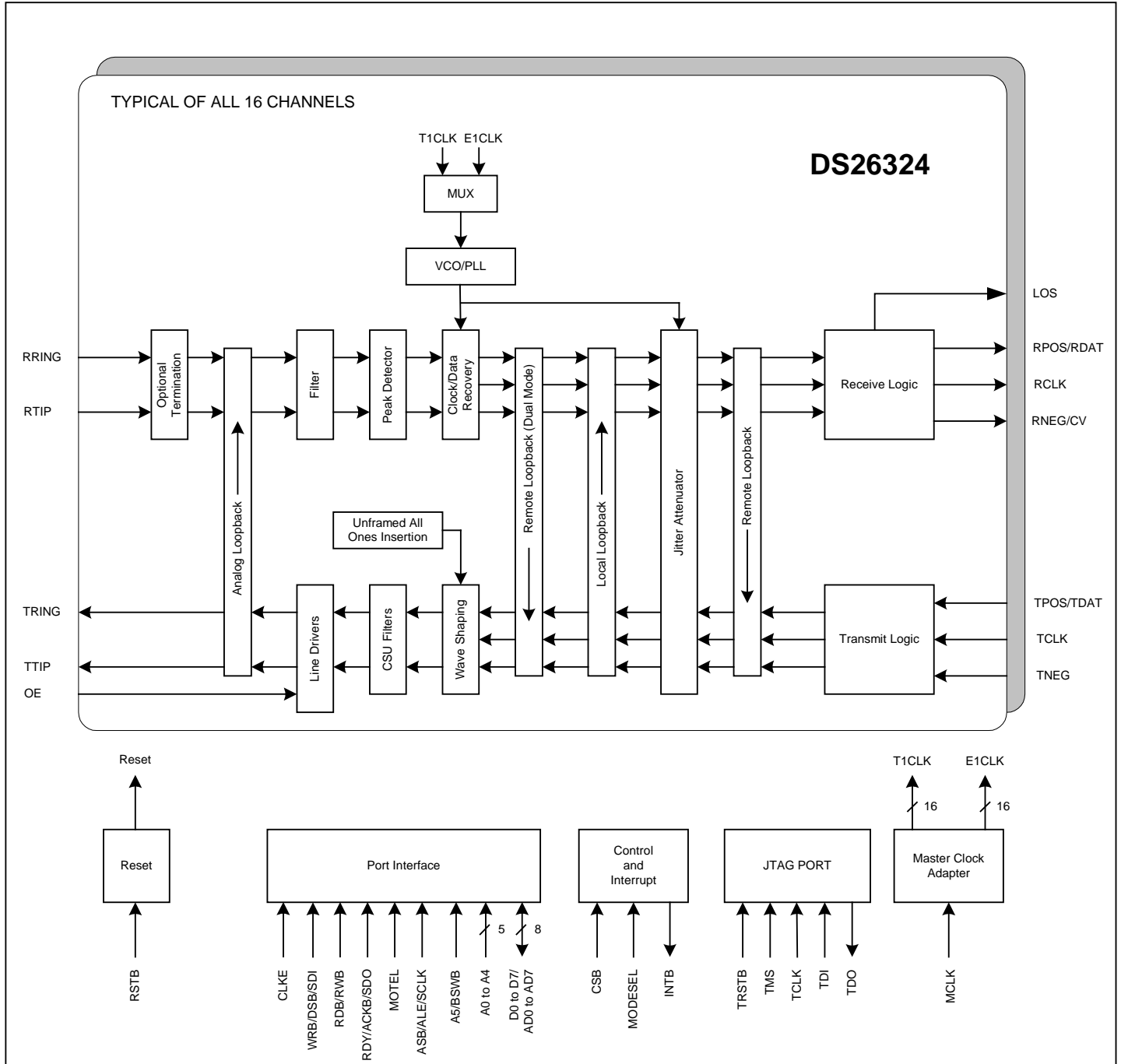

Figure 3-2. Receive Logic Detail

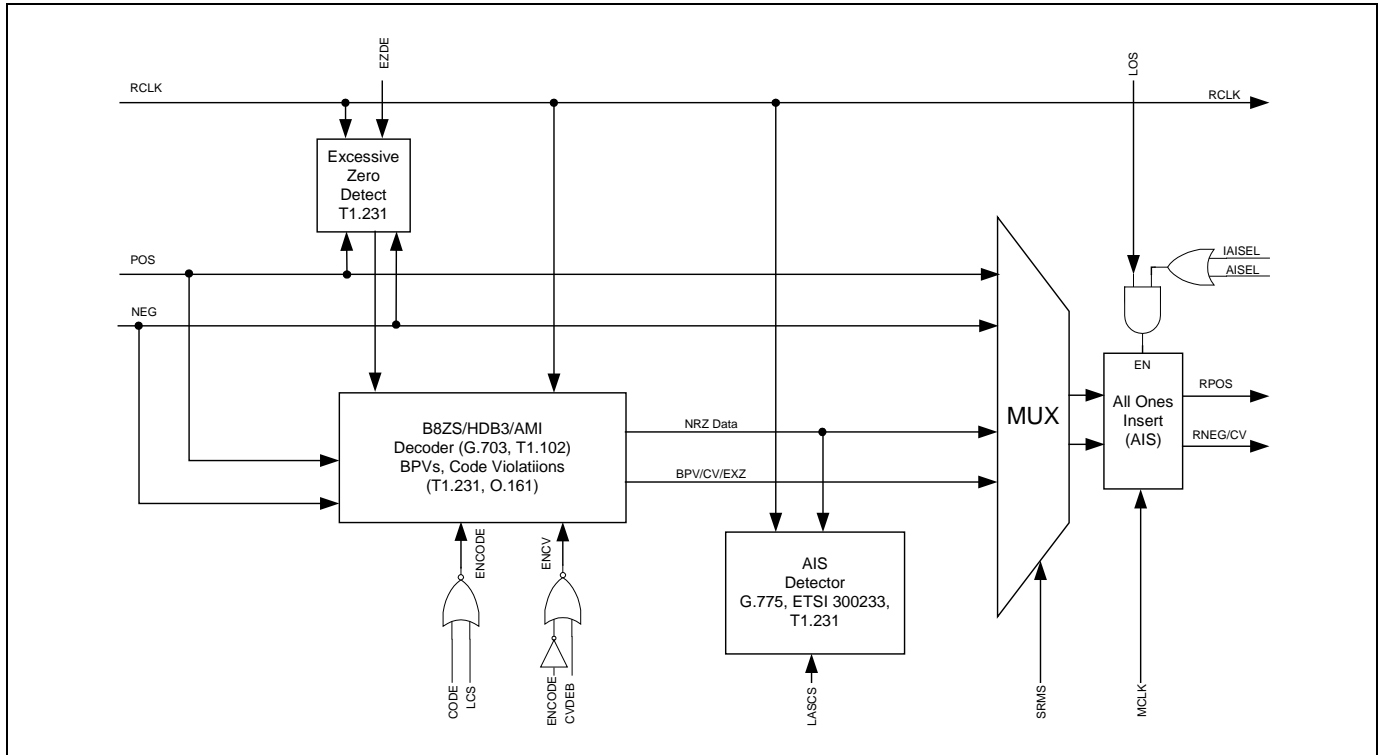
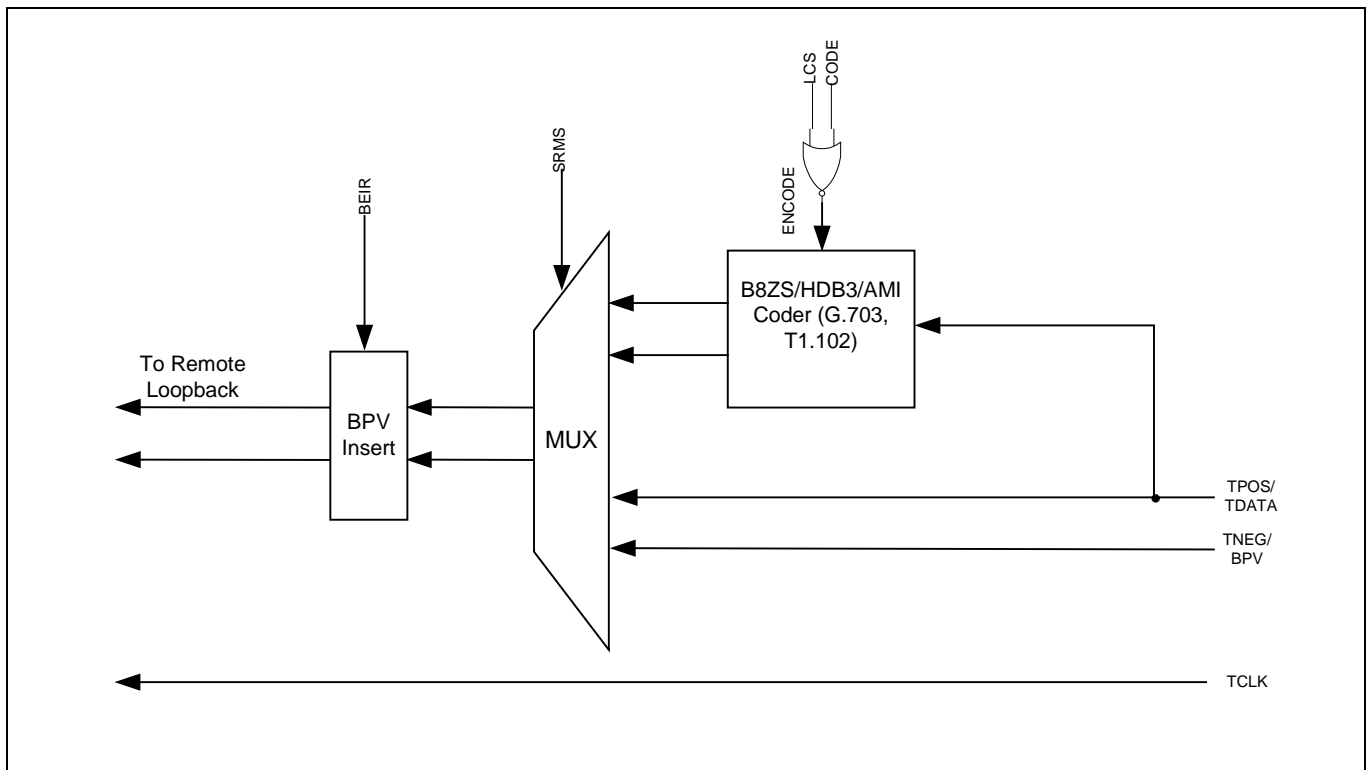

Figure 3-3. Transmit Logic Detail



4 PIN DESCRIPTION

Table 4-1. Pin Descriptions

NAME	PIN	TYPE	FUNCTION
ANALOG TRANSMIT AND RECEIVE			
TTIP1	E1	Analog output	<p>Transmit Bipolar Tip for Channels 1–16. These pins are differential line driver tip outputs. These pins can be high impedance if pin OE is low. When “1” is set in the Output Enable Register OE bit, the associated TTIPn pin will be enabled when the OE pin is high. The differential outputs of TTIPn and TRINGn can provide internal matched impedance for E1 75Ω, E1 120Ω, T1 100Ω, or J1 110Ω.</p> <p>If the TCLK input for a given LIU is held low for 64 MCLKs, that LIU’s transmitter is powered down and the TTIP/TRING outputs are high impedance.</p>
TTIP2	F1		
TTIP3	K1		
TTIP4	L1		
TTIP5	T5		
TTIP6	T6		
TTIP7	T10		
TTIP8	T11		
TTIP9	M16		
TTIP10	L16		
TTIP11	G16		
TTIP12	F16		
TTIP13	A12		
TTIP14	A11		
TTIP15	A7		
TTIP16	A6		
TRING1	E2	Analog output	<p>Transmit Bipolar Ring for Channels 1–16. These pins are differential line driver ring outputs. These pins can be high impedance if pin OE is low. When “1” is set in the Output Enable Register OE bit, the associated TRINGn pin will be enabled when the OE pin is high. The differential outputs of TTIPn and TRINGn can provide internal matched impedance for E1 75Ω, E1 120Ω, T1 100Ω, or J1 110Ω.</p> <p>If the TCLK input for a given LIU is held low for 64 MCLKs, that LIU’s transmitter is powered down and the TTIP/TRING outputs are high impedance.</p>
TRING2	F2		
TRING3	K2		
TRING4	L2		
TRING5	R5		
TRING6	R6		
TRING7	R10		
TRING8	R11		
TRING9	M15		
TRING10	L15		
TRING11	G15		
TRING12	F15		
TRING13	B12		
TRING14	B11		
TRING15	B7		
TRING16	B6		
RTIP1	A1	Analog input	<p>Receive Bipolar Tip for Channels 1–16. Receive analog input for differential receiver. Data and clock are recovered and output at RPOS/RNEG and RCLK pins, respectively. The differential inputs of RTIPn and RRINGn can provide internal impedance matching with external resistance for E1 75Ω, E1 120Ω, T1 100Ω, or J1 110Ω.</p>
RTIP2	C1		
RTIP3	H1		
RTIP4	N1		
RTIP5	T1		
RTIP6	T3		
RTIP7	T8		
RTIP8	T13		
RTIP9	T16		
RTIP10	P16		
RTIP11	J16		
RTIP12	D16		
RTIP13	A16		
RTIP14	A14		
RTIP15	A9		
RTIP16	A4		

NAME	PIN	TYPE	FUNCTION																
RESREF	R9	Analog input	Resistor Reference. If fully internal receive impedance match is selected, a 16kΩ ±1% resistor to GND is needed. If not used, tie pin low.																
RRING1	A2	Analog input	Receive Bipolar Ring for Channels 1–16. Receive analog input for differential receiver. Data and clock are recovered and output at RPOS/RNEG and RCLK pins, respectively. The differential inputs of RTIPn and RRINGn can provide internal impedance matching with external resistance for E1 75Ω, E1 120Ω, T1 100Ω, or J1 110Ω.																
RRING2	C2																		
RRING3	H2																		
RRING4	N2																		
RRING5	R1																		
RRING6	R3																		
RRING7	R8																		
RRING8	R13																		
RRING9	T15																		
RRING10	P15																		
RRING11	J15																		
RRING12	D15																		
RRING13	B16																		
RRING14	B14																		
RRING15	B9																		
RRING16	B4																		
DIGITAL Tx/Rx																			
TPOS1/TDATA1	F6	I	Transmit Positive Data Input for Channels 1–6. When DS26324 is configured in dual-rail mode, the data input to TPOSn is output as a positive pulse on the line (tip and ring). Transmit Data Input for Channels 1–16. When the device is configured in single-rail mode NRZ data is input to TDATA n. The data is sampled on the falling edge of TCLKn and encoded HDB3/B8ZS or AMI before being output to the line.																
TPOS2/TDATA2	G7																		
TPOS3/TDATA3	J6																		
TPOS4/TDATA4	K6																		
TPOS5/TDATA5	L9																		
TPOS6/TDATA6	N5																		
TPOS7/TDATA7	P12																		
TPOS8/TDATA8	M11																		
TPOS9/TDATA9	L11																		
TPOS10/TDATA10	J11																		
TPOS11/TDATA11	G11																		
TPOS12/TDATA12	C14																		
TPOS13/TDATA13	F9																		
TPOS14/TDATA14	E7																		
TPOS15/TDATA15	N12																		
TPOS16/TDATA16	D5																		
TNEG1	C3	I	Transmit Negative Data for Channels 1–16. When DS26324 is configured in dual-rail mode. The data input to TNEGn is output as a negative mark on the line. TPOS and TNEG in dual-rail mode result in positive and negative pulses sent on the line:																
TNEG2	J14			<table border="1"> <thead> <tr> <th>TPOSn</th> <th>TNEGn</th> <th>OUTPUT PULSE</th> </tr> </thead> <tbody> <tr> <td>0</td> <td>0</td> <td>Space</td> </tr> <tr> <td>0</td> <td>1</td> <td>Negative mark</td> </tr> <tr> <td>1</td> <td>0</td> <td>Positive mark</td> </tr> <tr> <td>1</td> <td>1</td> <td>Space</td> </tr> </tbody> </table>	TPOSn	TNEGn	OUTPUT PULSE	0	0	Space	0	1	Negative mark	1	0	Positive mark	1	1	Space
TPOSn	TNEGn				OUTPUT PULSE														
0	0				Space														
0	1				Negative mark														
1	0			Positive mark															
1	1			Space															
TNEG3	J5																		
TNEG4	G10																		
TNEG5	M6																		
TNEG6	P6																		
TNEG7	P7																		
TNEG8	K9																		
TNEG9	L12																		
TNEG10	J12																		
TNEG11	H11																		
TNEG12	E13																		
TNEG13	G8																		
TNEG14	F7																		
TNEG15	C6																		
TNEG16	C5																		

NAME	PIN	TYPE	FUNCTION
TCLK1	F5	I	<p>Transmit Clock for Channels 1–16. The transmit clock has to be 1.544MHz for T1 or 2.048MHz for E1 mode. TCLKn is the clock used to sample the data TPOS/TNEG or TDAT on the falling edge. The expected TCLK can be inverted.</p> <p>If TCLKn is 'high' for 16 or more MCLKs, then transmit all ones (TAOs) is sent to the line side of the corresponding transmit channel. When TCLKn starts clocking again, normal operation will begin again for the corresponding transmit channel.</p> <p>If TCLKn is 'low' for 64 or more MCLKs, then the corresponding transmit channel on the line side will power-down and be put into high impedance. When TCLKn starts clocking again the corresponding transmit channel will power-up and come out of high impedance.</p>
TCLK2	G4		
TCLK3	G9		
TCLK4	H6		
TCLK5	M7		
TCLK6	L8		
TCLK7	L10		
TCLK8	P9		
TCLK9	K11		
TCLK10	K12		
TCLK11	F14		
TCLK12	E12		
TCLK13	C11		
TCLK14	D12		
TCLK15	N7		
TCLK16	D11		
RPOS1/RDATA1	F4	O, tri-state	<p>Receive Positive Data Output for Channels 1–16. In dual-rail mode the NRZ data output indicates a positive pulse on RTIP/RRING. Upon detecting an LOS, AIS can be inserted if the AISEL bit in the GC (0Fh) register is set; otherwise, the pins will be active. AIS insertion can also be controlled on an individual LIU basis by the IAISEL (05h) register. If a given receiver is in power-down mode, the associated RPOS pin is high impedance.</p> <p>Receive Data Output for Channels 1–16. In single-rail mode, NRZ data is sent out on this pin. If a given receiver is in power-down mode, the associated RPOS pin is high impedance.</p> <p>Note: During an LOS condition, the RPOS/RDATA outputs remain active.</p>
RPOS2/RDATA2	F3		
RPOS3/RDATA3	L3		
RPOS4/RDATA4	L4		
RPOS5/RDATA5	K8		
RPOS6/RDATA6	M9		
RPOS7/RDATA7	P8		
RPOS8/RDATA8	M12		
RPOS9/RDATA9	M14		
RPOS10/RDATA10	K13		
RPOS11/RDATA11	G12		
RPOS12/RDATA12	E14		
RPOS13/RDATA13	C12		
RPOS14/RDATA14	C10		
RPOS15/RDATA15	C8		
RPOS16/RDATA16	E5		
RNEG1/CV1	E3	O, tri-state	<p>Receive Negative Data Output for Channels 1–16. In dual-rail mode the NRZ data output indicates a negative pulse on RTIP/RRING. Upon detecting a LOS, AIS can be inserted if AISEL bit in the GC register is set; otherwise, the pins will be active. AIS insertion can also be controlled on an individual LIU basis by IAISEL register. If a given receiver is in power-down mode, the associated RNEG pin is high impedance.</p> <p>Code Violation for Channels 1–16. In single-rail mode, bipolar violation, code violation, and excessive zeros are reported on CVn. If HDB3 or B8ZS is not selected, this pin indicates only BPVs. If a given receiver is in power-down mode, the associated CV pin is high impedance.</p>
RNEG2/CV2	G5		
RNEG3/CV3	K4		
RNEG4/CV4	M3		
RNEG5/CV5	L7		
RNEG6/CV6	M10		
RNEG7/CV7	P11		
RNEG8/CV8	K10		
RNEG9/CV9	M13		
RNEG10/CV10	L14		
RNEG11/CV11	F13		
RNEG12/CV12	F11		
RNEG13/CV13	E10		
RNEG14/CV14	C9		
RNEG15/CV15	C7		
RNEG16/CV16	J3		

NAME	PIN	TYPE	FUNCTION
RCLK1	D3	O, tri-state	Receive Clock for Channels 1–16. The receive data (RPOS/RNEG) is clocked out on the rising edge of RCLK. If a given receiver is in power-down mode the RCLK is high impedance. Upon an LOS being detected, the RCLK is switched from the recovered clock to MCLK. RCLK can be inverted by the RCLKI register.
RCLK2	G6		
RCLK3	K3		
RCLK4	K5		
RCLK5	P5		
RCLK6	M8		
RCLK7	P10		
RCLK8	P13		
RCLK9	L13		
RCLK10	K14		
RCLK11	G13		
RCLK12	F12		
RCLK13	E8		
RCLK14	E9		
RCLK15	F8		
RCLK16	E6		
MCLK	H12	I	Master Clock. This is an independent free-running clock that can be a multiple of 2.048MHz \pm 50ppm for E1 mode or 1.544MHz \pm 50ppm for T1 mode. The clock selection is available by MC bits MPS0, MPS1, FREQS, and PLLE. A multiple of 2.048MHz can be internal adapted to 1.544MHz and a multiple of 1.544MHz can be internal adapted to 2.048MHz.
LOS1	D2	O	Loss-of-Signal Output. This output goes high when there is no transition on the received signal over a specified interval. The output will go low when there is sufficient ones density in the received signal. The LOS criteria for assertion and desertion criteria are described in Section 5.5.6 . The LOS outputs can be configured to comply with T1.231, ITU-T G.775, or ETS 300 233. T1/E1 Clock (TECLK) (Ball E11 only). This output becomes a T1 or E1 programmable clock output when enabled by register MC . For T1 or E1 frequency selection, see the CCR register. Clock A (CLKA) (Ball F10 only). This output becomes a programmable clock output when enabled by register MC . For frequency options, see CCR register.
LOS2	G2		
LOS3	J2		
LOS4	M2		
LOS5	R2		
LOS6	T2		
LOS7	R4		
LOS8	R7		
LOS9	R14		
LOS10	N15		
LOS11	K15		
LOS12	H15		
LOS13	B10		
LOS14	B8		
LOS15/TECLK	E11		
LOS16/CLKA	F10		
HOST SELECTION			
MODESEL	A3	I	Mode Selection. This pin is used to select the control mode of the DS26324: Low → Serial Host Mode High → Parallel Host Mode
MOTEL	B3	I	Motorola Intel Select. When this pin is low, Motorola mode is selected. When this pin is high Intel mode is selected.
CSB	P14	I	Chip Select Bar. This signal must be low during all accesses to the registers.

NAME	PIN	TYPE	FUNCTION
SCLK/ALE/ASB	N14	I	<p>Shift Clock. In the serial host mode, this pin is the serial clock. Data on SDI is clocked on the rising edge of SCLK. The data is clocked on SDO on the rising edge of SCLK if CLKE is high. If CLKE is low the data on SDO is clocked on the falling edge of SCLK.</p> <p>Address Latch Enable. In parallel Intel multiplexed mode, the address lines are latched on the falling edge of ALE.</p> <p>Address Strobe Bar. In parallel Motorola multiplexed mode, the address is sampled on the falling edge of ASB.</p> <p>Note: Tie ALE/ASB pin high if using nonmuxed mode.</p>
RDB/RWB	H14	I	<p>Read Bar. In Intel host mode, this pin must be low for read operation.</p> <p>Read Write Bar. In Motorola mode, this pin is low for write operation and high for read operation.</p>
SDI/WRB/DSB	G14	I	<p>Serial Data Input. In the serial host mode, this pin is the serial input SDI; it is sampled on the rising edge of SCLK.</p> <p>Write Bar. In Intel host mode, this pin is active low during write operation. The data or address (multiplexed mode) is sampled on the rising edge of WRB.</p> <p>Data Strobe Bar. In the parallel Motorola mode, this pin is active low. During a write operation the data or address is sampled on the rising edge of DSB. During a read operation the data or address is driven on the rising edge of DSB. In the nonmultiplexed Motorola mode the address bus (A[5:0]) is latched on the falling edge of DSB.</p>
SDO/RDYB/ACKB	C13	O	<p>Serial Data Out. In serial host mode, the SDO data is output on this pin. If a serial write is in progress this pin is high impedance. During a read SDO is high impedance when the SDI is in command/address mode. If CLKE is low SDO is output on the rising edge of SCLK, if CLKE is high on the falling edge.</p> <p>Ready Bar Output. A high on this pin reports to the host that the cycle is not complete and wait states must be inserted. A low means the cycle is complete.</p> <p>Acknowledge Bar. In Motorola parallel mode, a low on this pin indicates that the read data is available for the Host or that the written data cycle is complete.</p>
INTB	D7	O, open drain	<p>Interrupt Bar (Active Low). This signal is tri-state when RSTB pin is low. This interrupt signal is driven low when an event is detected on any of the enabled interrupt sources in any of the register banks. When there are no active and enabled interrupt sources, the pin can be programmed to either drive high or as open drain. The reset default is open drain when there are no active enabled interrupt sources. All interrupt sources are disabled when RSTB = 0 and they must be programmed to be enabled.</p>

NAME	PIN	TYPE	FUNCTION
D7/AD7	N3	I/O, tri-state	<p>Data Bus 7–0. In nonmultiplexed host mode, these pins are the bidirectional data bus.</p> <p>Address/Data Bus 7–0. In multiplexed host mode, these pins are the bidirectional address/data bus. Note: AD7 and AD6 do not carry address information.</p> <p>In serial host mode, these pins should be grounded.</p>
D6/AD6	P3		
D5/AD5	M4		
D4/AD4	L5		
D3/AD3	K7		
D2/AD2	P4		
D1/AD1	M5		
D0/AD0	L6		
A5/BSWP	E4	I	<p>Address 5. In the host nonmultiplexed mode, this is the most significant bit of the address bus.</p> <p>Bit Swap. In serial host mode, this bit defines the serial data position to be MSB first when low and LSB first when high.</p> <p>In multiplexed host mode, this pin should be grounded.</p>
A4	C4	I	<p>Address Bus 4–0. These five pins are address pins in the parallel host mode.</p> <p>In serial host mode and multiplexed host mode, these pins should be grounded.</p>
A3	H5		
A2	G3		
A1	H3		
A0	N10		
OE	R12	I	<p>Output Enable. If this pin is pulled low all the transmitters outputs (TTIP and TRING) are high impedance. If pulled high all the transmitters are enabled when the associated output enable OE bit is set. If TST.RHPMC is set, the OE pin is granted control of the receiver internal termination. When OE is low, receiver internal termination will be high impedance. When OE is high, receiver termination will be enabled. The receiver can still monitor incoming signals even when termination is in high impedance.</p>
CLKE/MUX	T14	I	<p>Clock Edge. If CLKE is high, SDO is clocked out on falling edge of SCLK and if low SDO is on rising edge of SCLK.</p> <p>Multiplexed/Nonmultiplexed Select Pin. When in parallel port mode, this pin is used to select multiplexed address and data operation or separate address and data. When mux is a high multiplexed address and data is used and when mux is low nonmultiplexed is used.</p>
JTAG			
TRSTB	E15	I, pullup	<p>JTAG Test Port Reset. This pin if low will reset the JTAG port. If not used it can be left unconnected.</p>
TMS	B13	I, pullup	<p>JTAG Test Mode Select. This pin is clocked on the rising edge of TCK and is used to control the JTAG selection between scan and Test Machine control.</p>
TCK	D14	I	<p>JTAG Test Clock. The data TDI and TMS are clocked on rising edge of TCK and TDO is clocked out on the falling edge of TCK.</p>
TDO	A15	O, high-Z	<p>JTAG Test Data Out. This is the serial output of the JTAG port. The data is clocked out on the falling edge of TCK.</p>
TDI	B15	I, pullup	<p>Test Data Input. This pin input is the serial data of the JTAG Test. The data on TDI is clocked on the rising edge of TCK. This pin can be left unconnected.</p>

NAME	PIN	TYPE	FUNCTION
RESET			
RSTB	B5	I, pullup	Reset Bar. This is the asynchronous reset input bar. It is internally pulled high. A 1 μ s low on this pin will reset the DS26324 registers to default value.
POWER SUPPLIES			
DVDD	H8, J9	I	3.3V Digital Power Supply
DVSS	H9, J8	I	Digital Ground
VDDT1	D1	I, high-Z	3.3V Power Supply for the Transmitter. All VDDT pins must be connected to VDDT, which has to be 3.3V.
VDDT2	G1		
VDDT3	J1		
VDDT4	M1		
VDDT5	T4		
VDDT6	T7		
VDDT7	T9		
VDDT8	T12		
VDDT9	N16		
VDDT10	K16		
VDDT11	H16		
VDDT12	E16		
VDDT13	A13		
VDDT14	A10		
VDDT15	A8		
VDDT16	A5		
GNDT1	D4	I	Analog Ground for Transmitters
GNDT2	H4		
GNDT3	J4		
GNDT4	N4		
GNDT5	N6		
GNDT6	N8		
GNDT7	N9		
GNDT8	N11		
GNDT9	N13		
GNDT10	J13		
GNDT11	H13		
GNDT12	D13		
GNDT13	D10		
GNDT14	D9		
GNDT15	D8		
GNDT16	D6		
AVDD	B1, C16, P1, R16, H7, J10	I	3.3V Analog Core Power Supply. Decouple each pin separately.
AVSS	B2, C15, P2, R15, H10, J7	I	Analog Core Ground

5 FUNCTIONAL DESCRIPTION

5.1 Port Operation

5.1.1 Serial Port Operation

Setting MODESEL = 'low' enables the serial bus interface on the DS26324. Port read/write timing is unrelated to the system transmit and receive timing, allowing asynchronous reads or writes by the host. See Section 9.3 for the AC timing of the serial port. All serial port accesses are LSB first when BSWP pin is high and MSB first when BSWP is low. Figure 5-1 to Figure 5-3 show operation with LSB first.

This port is compatible with the SPI interface defined for Motorola Processors. An example of this is the MMC2107 from Motorola.

Reading or writing to the internal registers requires writing one address/command byte prior to transferring register data. The first bit written (LSB) of the address/command byte specifies whether the access is a read (1) or a write (0). The next 6 bits identify the register address (A1 to A6) (A7 is ignored).

All data transfers are initiated by driving the CSB input low. When CLKE is low, SDO data is output on the rising edge of SCLK and when CLKE is high, data is output on the falling edge of SCLK. Data is held until the next falling or rising edge. All data transfers are terminated if CSB input transitions high. Port control logic is disabled and SDO is tri-stated when CSB is high. SDI is always sampled on the rising edge of SCLK.

Figure 5-1. Serial Port Operation for Write Access

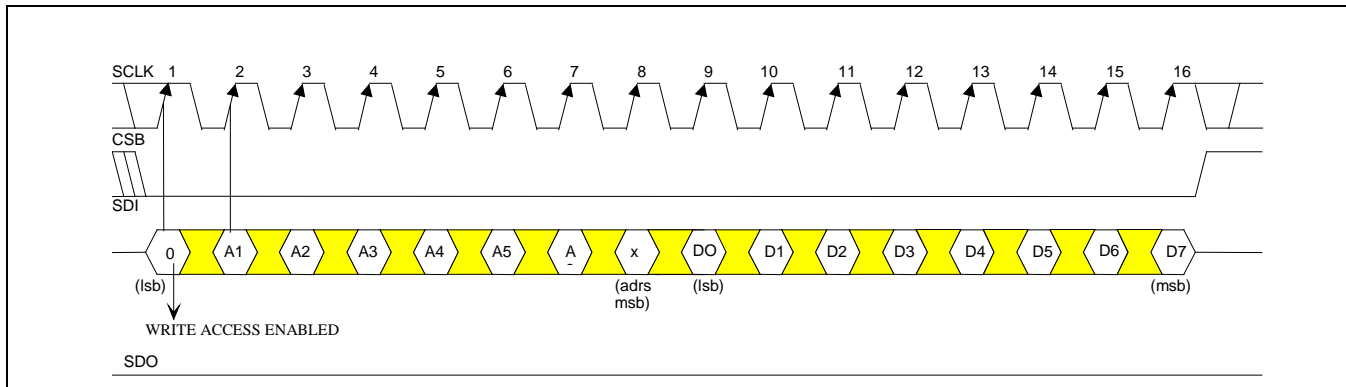

Figure 5-2. Serial Port Operation for Read Access with CLKE = 0

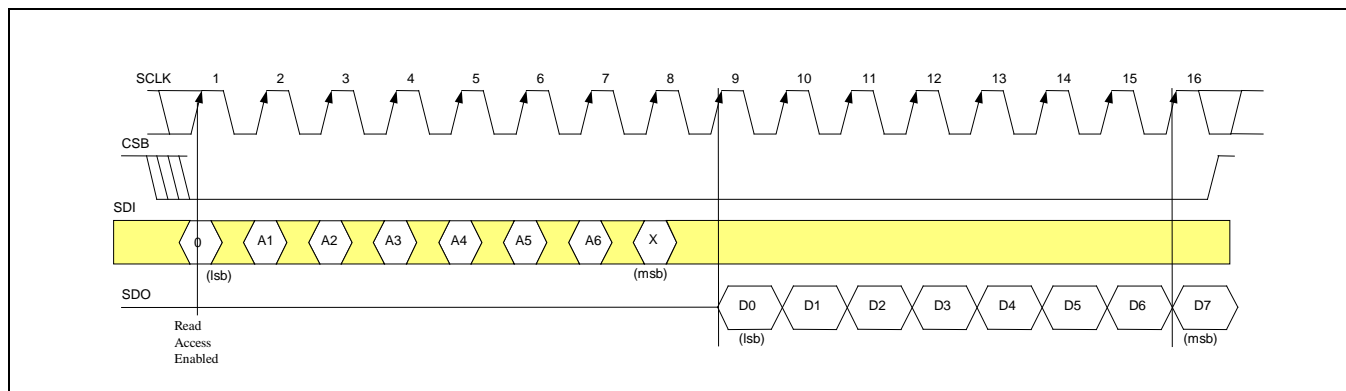
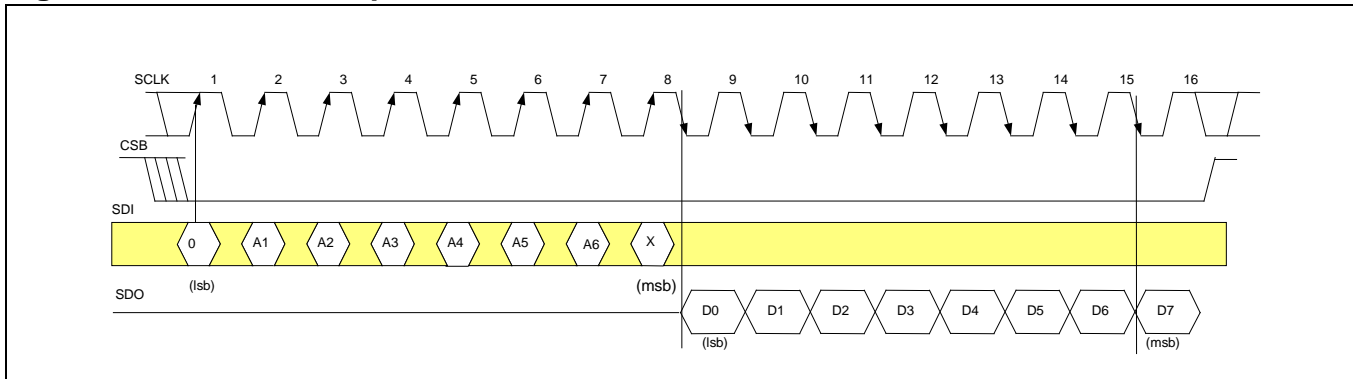

Figure 5-3. Serial Port Operation for Read Access with CLKE = 1

5.1.2 Parallel Port Operation

When using the parallel interface on the DS26324 the user has the option for either multiplexed bus operation or nonmultiplexed bus operation. The ALE pin is pulled high in nonmultiplexed bus operation. The DS26324 can operate with either Intel or Motorola bus-timing configurations selected by MOTEL pin. This pin being high selects the Intel mode. The parallel port is only operational if MODESEL pin is pulled high. The following Table lists all the pins and their functions in the parallel port mode. See the timing diagrams in Section 9 for more details.

Table 5-1. Parallel Port Mode Selection and Pin Functions

MODESEL, MOTEL, MUX	PARALLEL HOST INTERFACE	ADDRESS, DATA, AND CONTROL
100	Nonmultiplexed Motorola	CSB, ACKB, DSB, RWB, ASB, A[5:0], D[7:0], INTB
110	Nonmultiplexed Intel	CSB, RDYB, WRB, RDB, ALE, A[5:0], D[7:0], INTB
101	Multiplexed Motorola	CSB, ACKB, DSB, RWB, ASB, AD[7:0], INTB
111	Multiplexed Intel	CSB, RDYB, WRB, RDB, ALE, AD[7:0], INTB

5.1.3 Interrupt Handling

There are four sets of events that can potentially trigger an Interrupt. The interrupt functions as follows:

- When status changes on an interruptible event, INTB pin will go low if the event is enabled through the corresponding Interrupt Enable Register. The INTB has to be pulled high externally with a 10kΩ resistor for wired-OR operation. If a wired-OR operation is not required, the INTB pin can be configured to be high when not active by setting register [GISC.INTM](#).
- When an Interrupt occurs the Host Processor has to read the Interrupt Status register to determine the source of the Interrupt. The read will also clear the Interrupt Status register and this will clear the output INTB pin. The Interrupt Status register can also be configured as clear on write as per register [GISC.CWE](#). When set to clear on write, and interrupt status register bit (and the interrupt it generates) will only be cleared on writing a '1' to it's bit location in the interrupt status register. This makes it possible to clear interrupts on some bits in a register without clearing them on all bits.
- Subsequently the host processor can read the corresponding Status Register to check the real-time status of the event.

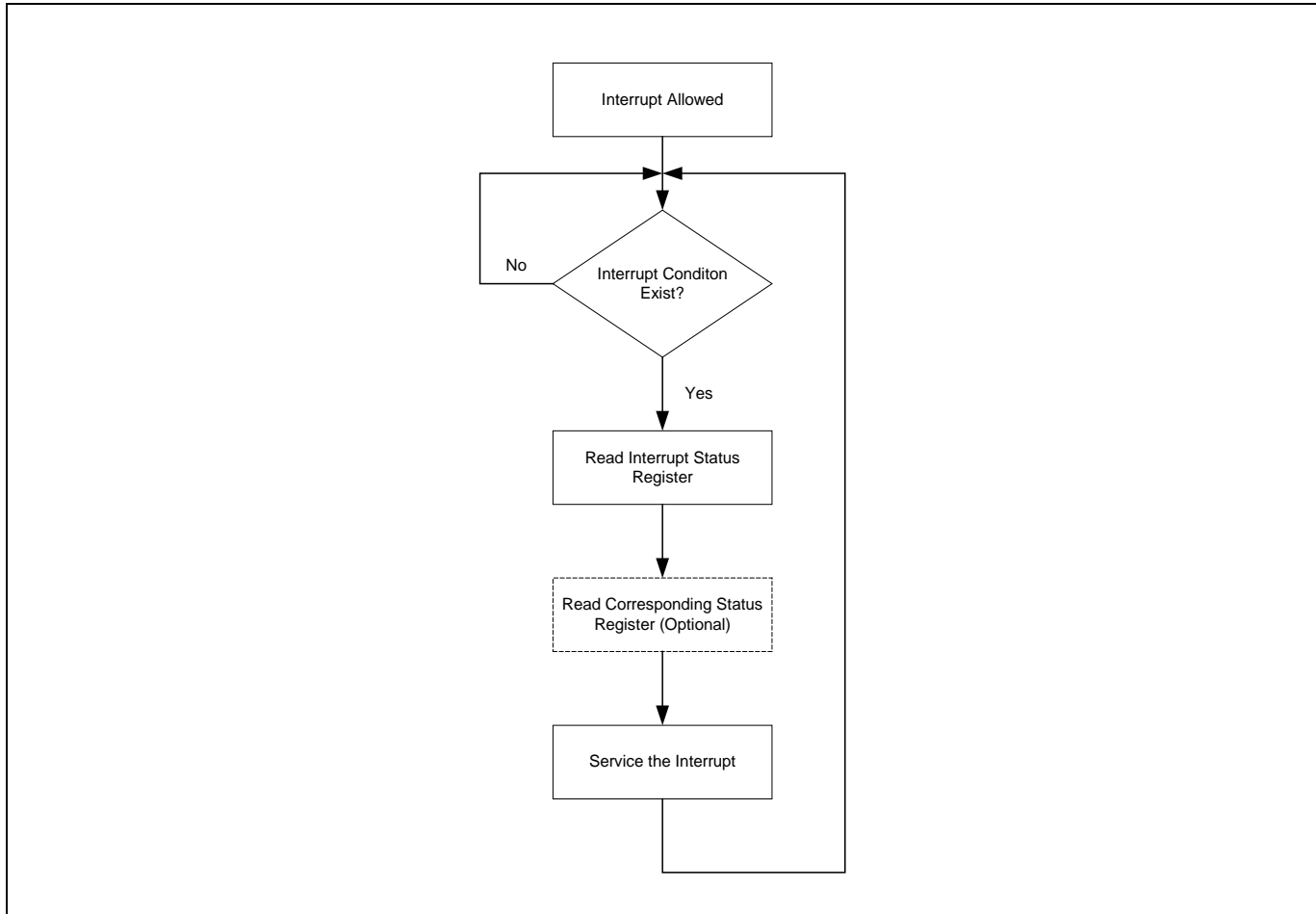
Figure 5-4. Interrupt Handling Flow Diagram

5.2 Power-Up and Reset

Internal Power_On_Reset circuitry generates a reset during power-up. All registers are reset to the default values. Writing to the Software Reset Register generates at least 1 μ s reset cycle, which has the same effect as the power-up reset.

The DS26324 can be reset by a low going pulse on the RSTB pin (see [Table 4-1](#)). A reset can also be performed in software by writing any value to the [SWR](#) register.

5.3 Master Clock

The DS26324 requires 2.048MHz \pm 50ppm or 1.544MHz \pm 50ppm or multiple thereof. The receiver uses the MCLK as a reference for clock recovery, jitter attenuation and generating RCLK during LOS. The AIS tTransmission uses MCLK for transmit all ones condition. See register [MC](#) to set desired incoming frequency. When the PLLE bit is set, the master clock adapter will generate both 2.048MHz (E1) and 1.544MHz (T1) clocks. If the PLLE bit is clear, both internal reference clocks will track MCLK.

MCLK or RCLK can also be used to output CLKA on the LOS16 pin. Register [CCR](#) is used to select the clock generated for CLKA and the TECLK. Any RCLK can also be selected as an input to the clock generator using this same register. For a detailed description of selections available see [Figure 5-5](#).

Figure 5-5. Prescaler PLL and Clock Generator

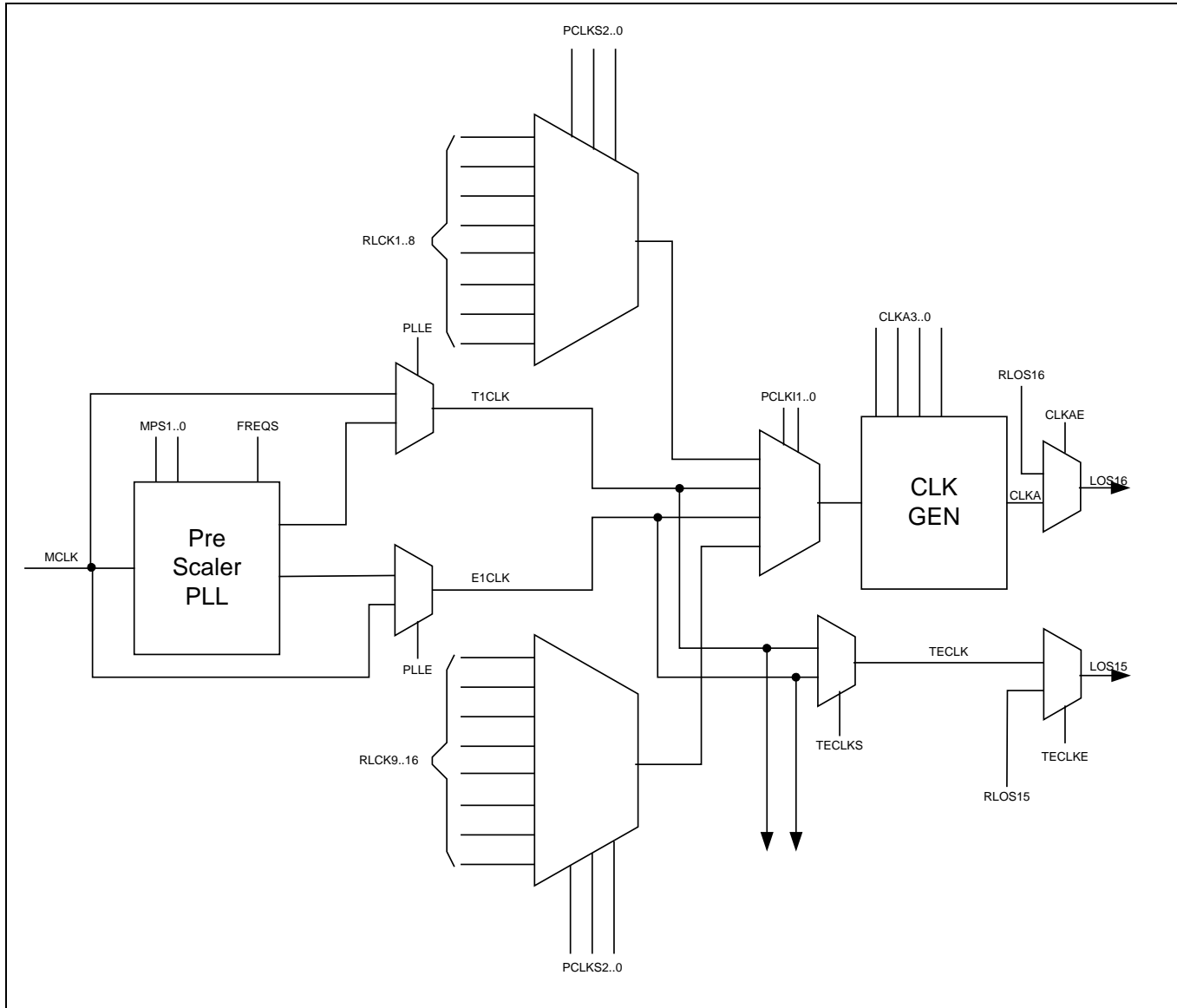

5.4 Transmitter

NRZ data arrives on TPOS and TNEG on the transmit system side. The TPOS and TNEG data is sampled on the falling edge of TCLK.

The data is encoded with HDB3 or B8ZS or AMI encoding when single-rail mode is selected (only TPOS as the data source). When in single-rail mode only, BPV errors can be inserted for test purposes by register [BEIR](#). Pre-encoded data is expected when dual-rail mode is selected. The encoded data passes through a jitter attenuator if it is enabled for the transmit path. A digital sequencer and DAC are used to generate transmit waveforms compliant with T1.102 and G.703 pulse masks.

The line driver supports internal impedance matching for 75Ω, 100Ω, 110Ω, and 120Ω modes.

The DS26324 drivers have short and open circuit driver fail monitor detection. There is an OE pin that can high impedance the transmitter outputs for protection switching when low. The individual transmitters are by default in high impedance. The [OE](#) register is used to enable the transmitters individually when the OE pin is high. The DS26324 has to have the transmitter's enabled by setting the register and then pulling the OE pin high. The registers that control the transmitter operation are shown in [Table 5-2](#).

Table 5-2. Telecommunications Specification Compliance for DS26324 Transmitters

TRANSMITTER FUNCTION	TELECOMMUNICATIONS COMPLIANCE
AMI Coding, B8ZS Substitution, DS1 Electrical Interface	ANSI T1.102
T1 Telecom Pulse Mask compliance	ANSI T1.403
T1 Telecom Pulse Mask compliance	ANSI T1.102
Transmit Electrical Characteristics for E1 Transmission and Return Loss Compliance	ITU-T G.703

Table 5-3. Registers Related to Control of DS26324 Transmitters

REGISTER	NAME	FUNCTION
Transmit All Ones Enable	TAOE	Transmit all ones enable.
Driver Fault Monitor Status	DFMS	Driver fault status.
Driver Fault Monitor Interrupt Enable	DFMIE	Driver fault status interrupt mask.
Driver Fault Monitor Interrupt Status	DFMIS	Driver fault status interrupt mask.
Automatic Transmit All Ones Select	ATAOS	Transmit all ones enabled automatically on LOS.
Global Configuration	GC	Global control of jitter attenuator, line coding and short circuit protection.
Template Select Transmitter	TST	The transmitter that the Template Select Transmitter Register applies to.
Template Select	TS	The TS2 to TS0 bits for selection of the templates for transmitter and TIMPOFF and TIMPRIM bits to control transmit impedance match.
Output Enable Configuration	OE	These register bits can be used to enable the transmitter outputs.
Master Clock Selection	MC	Selects the MCLK frequency used for transmit and receive.
Single-Rail Mode Select	SRMS	This register can be used to select between single-rail and dual-rail mode.
Line Code Selection	LCS	The individual transceiver line codes can be selected to overwrite the global setting.
Transmit Power-Down Enable	TPDE	Individual transmitters can be powered down.
Individual Jitter Attenuator Enable	IJAЕ	Enables the jitter attenuator.
Individual Jitter Attenuator Position Select	IJAPS	Selects whether jitter attenuator is in transmit or receive path
Individual Jitter Attenuator FIFO Depth Select	IJAFDS	Selects depth of jitter attenuator FIFO.
Individual Jitter Attenuator FIFO Limit Trip	IJAFLT	Indicates jitter attenuator FIFO within 4 bits of its useful limit.
Individual Short-Circuit Protection Disable	ISCPD	This register allows the individual transmitters to have short-circuit protection disable.
Bit Error Rate Tester Control	BTCR	This register allows mapping of the internal BERTs into an individual transmit path.
Transmit Clock Invert	TCLKI	Inverts TCLK input.
BPV Error Insertion	BEIR	Inserts a bipolar error in the transmit path when in single-rail mode.

5.4.1 Transmit Line Templates

The DS26324 transmitters can be selected individually to meet the pulse masks for E1 and T1/J1 mode. The T1/J1 pulse mask is shown in the Transmit Pulse Template and can be configured on an individual LIU basis. The transmit template is selected via the TS2-TS0 bits in the [TS](#) register. Transmit impedance matching is selected using the TIMPOFF and the TIMPRM bits of the same register. When transmit impedance matching is enabled TIMPRM will select between 75Ω and 120Ω impedance if an E1 template is selected, and between 100Ω and 110Ω impedance if a T1/J1 template is selected. In E1 mode, if 75Ω is selected via the TIMPRM bit, the output pulse amplitude will be 2.37V, if 120Ω is selected via the TIMPRM bit, the output pulse amplitude will be 3.0V.

The E1 pulse template is shown in [Figure 5-7](#) and the T1 pulse template is shown in [Figure 5-6](#).

Table 5-4. Template Selections for Short-Haul Mode

TS2, TS1, TS0	APPLICATION
000	E1
001	Reserved
010	
011	
100	DSX-1 (0–133ft)
101	DSX-1 (133–266ft)
110	DSX-1 (266–399ft)
111	DSX-1 (399–533ft)
	DSX-1 (533–655ft)

Figure 5-6. T1 Transmit Pulse Templates

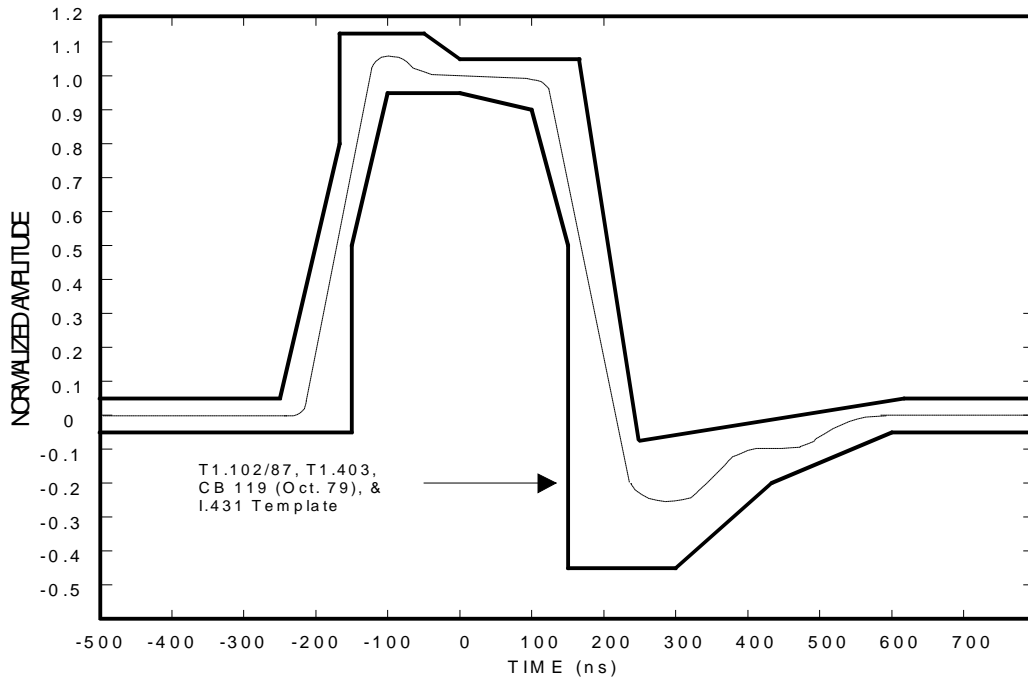

DSX-1 Template (per ANSIT1.102 -1993)

MAXIMUM CURVE	UI	Time	Amp.
-0.77	-500	0.05	
-0.39	-255	0.05	
-0.27	-175	0.80	
-0.27	-175	1.15	
-0.12	-75	1.15	
0.00	0	1.05	
0.27	175	1.05	
0.35	225	-0.07	
0.93	600	0.05	
1.16	750	0.05	

MINIMUM CURVE	UI	Time	Amp.
-0.77	-500	-0.05	
-0.23	-150	-0.05	
-0.23	-150	0.50	
-0.15	-100	0.95	
0.00	0	0.95	
0.15	100	0.90	
0.23	150	0.50	
0.23	150	-0.45	
0.46	300	-0.45	
0.66	430	-0.20	
0.93	600	-0.05	
1.16	750	-0.05	

DS1 Template (per ANSIT1.403 -1995)

MAXIMUM CURVE	UI	Time	Amp.
-0.77	-500	0.05	
-0.39	-255	0.05	
-0.27	-175	0.80	
-0.27	-175	1.20	
-0.12	-75	1.20	
0.00	0	1.05	
0.27	175	1.05	
0.34	225	-0.05	
0.77	600	0.05	
1.16	750	0.05	

MINIMUM CURVE	UI	Time	Amp.
-0.77	-500	-0.05	
-0.23	-150	-0.05	
-0.23	-150	0.50	
-0.15	-100	0.95	
0.00	0	0.95	
0.15	100	0.90	
0.23	150	0.50	
0.23	150	-0.45	
0.46	300	-0.45	
0.61	430	-0.26	
0.93	600	-0.05	
1.16	750	-0.05	

Figure 5-7. E1 Transmit Pulse Templates

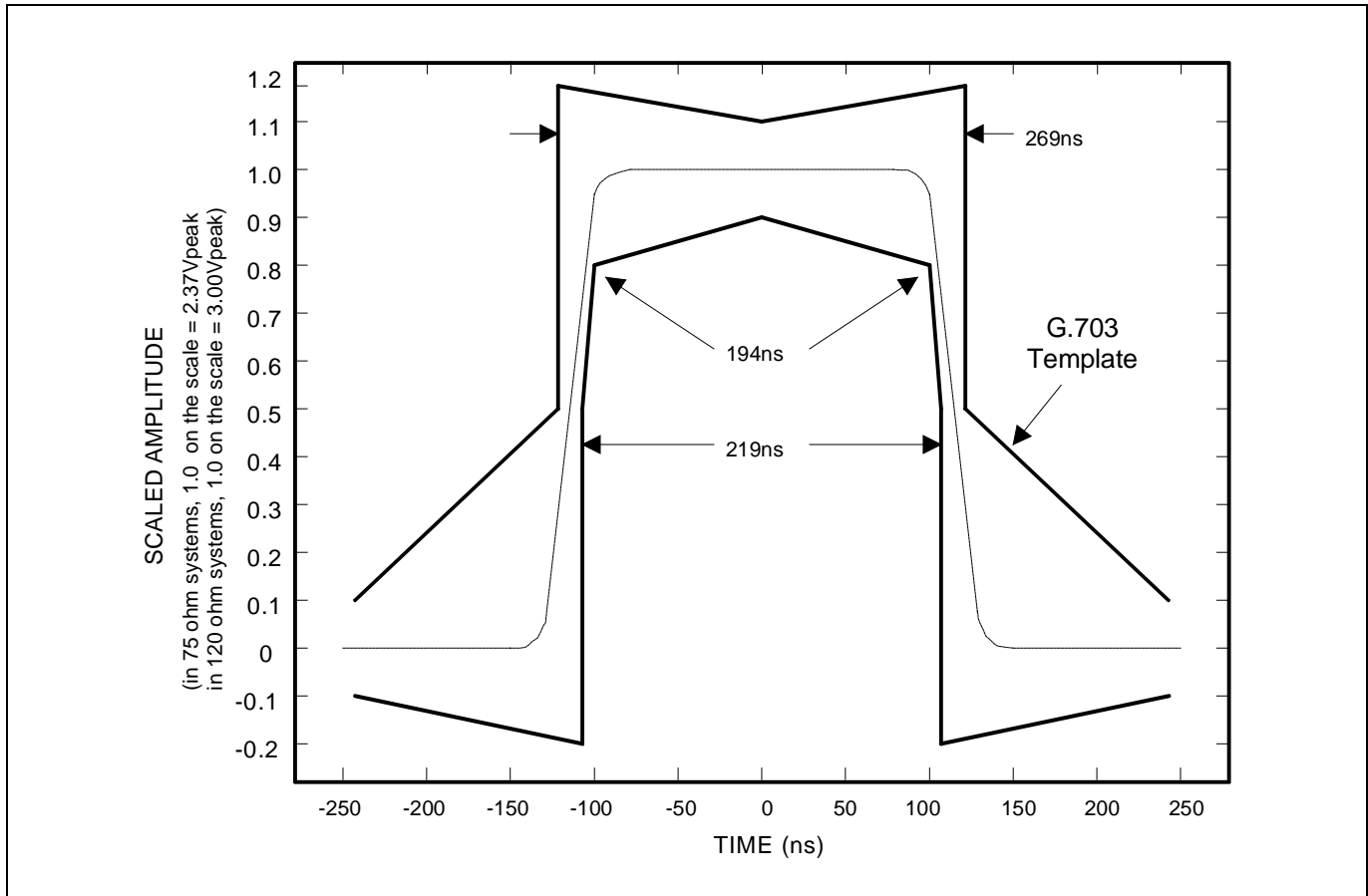

5.4.2 LIU Transmit Front-End

It is recommended that the LIU for the transmitter be configured as described in [Figure 5-8](#) and in [Table 5-5](#).

Figure 5-8. LIU Front-End

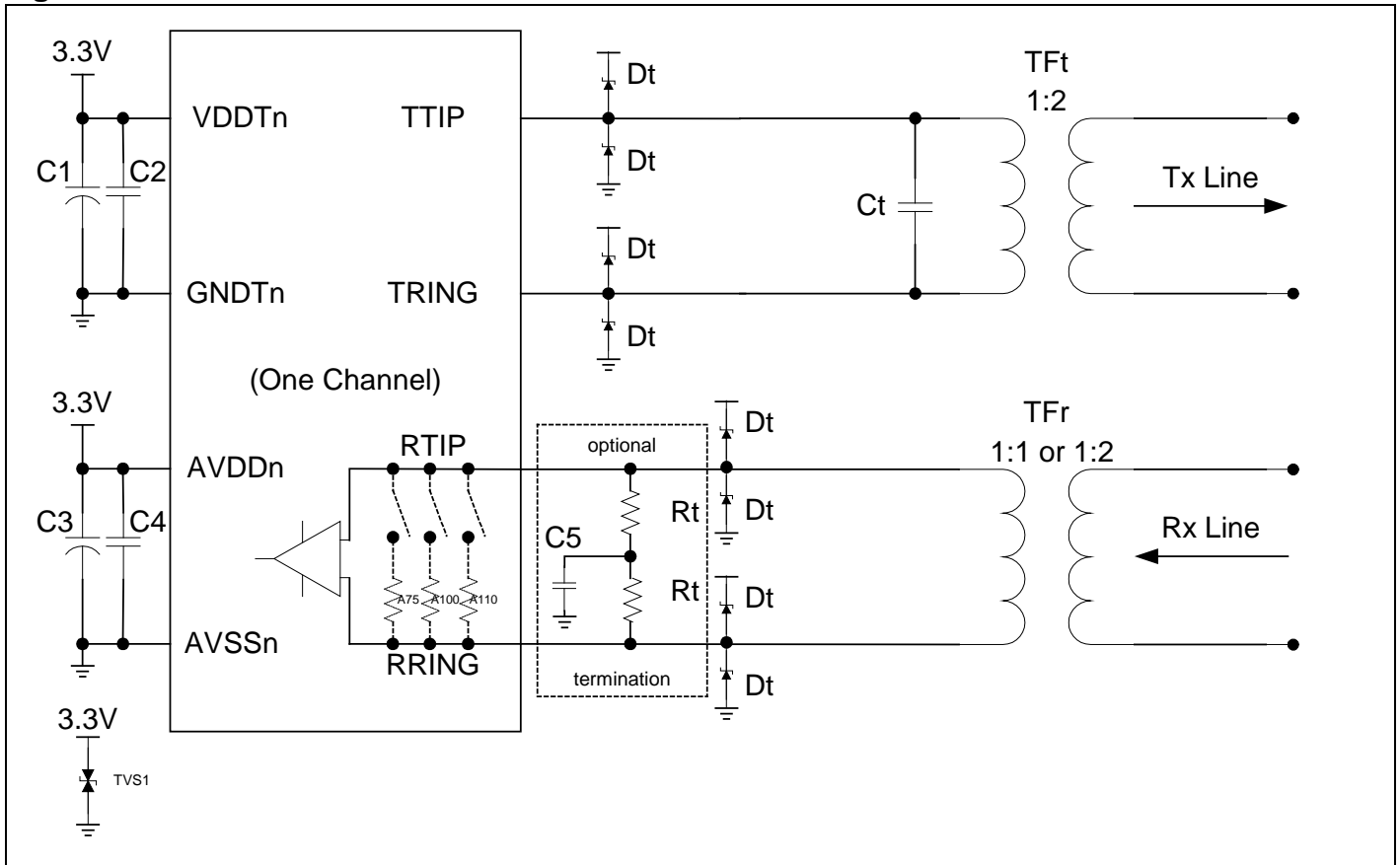

Table 5-5. LIU Front-End Values

MODE	COMPONENT	75Ω COAX, 120Ω TWISTED PAIR, 100/110Ω TWISTED PAIR
Tx Capacitance	Ct	560pF typical. Adjust for board parasitics for optimal return loss.
Tx Protection	Dt ¹	International Rectifier 11DQ04 or 10BQ060, Motorola MBR0540T1
Rx Transformer RTR 1:1	TFr	Pulse TX1475
Tx Transformer 1:2	TFt	Halo TG83-S005NU
Rx Transformer RTR 1:2	TFr	Pulse T1124 (0°C to +70°C), Pulse T1114 (-40°C to 85°C)
Tx Transformer 1:2	TFt	
Tx Decoupling (TVDDn)	C1	Common decoupling for all 16 channels = 68μF.
Tx Decoupling (TVDDn)	C2	Recommended decoupling per channel = 0.1μF.
Rx Decoupling (AVDD)	C3	Common decoupling for all 16 channels = 68μF.
Rx Decoupling (AVDD)	C4	Decouple all six pins separately with a 0.1μF capacitor.
Rx Termination	C5 ¹	Rx capacitance for all 16 channels = 0.1μF.
Rx Termination RTR 1:1	Rt ¹	Need two resistors = 60.4Ω ±1%.
Rx Termination RTR 1:2	Rt ¹	Need two resistors = 15.0Ω ±1%.
Voltage Protection	TVS1	SGS-Thomson SMLVT 3V3 (3.3V Transient Suppressor)

¹Only use if necessary for application.

5.4.3 Transmit Dual-Rail Mode

Transmit dual-rail mode consists of the TPOS, TNEG, and TCLK pins on the system side. NRZ data is sampled on the falling edge of TCLK as shown in [Figure 9-12](#).

B8ZS or HDB3 encoding is not available in transmit dual-rail mode. The data that appears on the TPOS and TNEG pins is output on TTIP and TRING without any modification. The Single-Rail Mode Select Register ([SRMS](#)) is used for selection of dual-rail or single-rail mode. The data that arrives at the TPOS and TNEG can be overwritten in the maintenance mode by setting the BERT Control Register ([BTCR](#)).

5.4.4 Transmit Single-Rail Mode

Transmit single-rail mode consists of the TPOS and TCLK pins on the system side (TNEG is not used.). NRZ data is sampled on the falling edge of TCLK as shown in [Figure 9-12](#). The zero substitution B8ZS or HDB3 encoding is allowed. The TPOS data is encoded in AMI or B8ZS/HDB3 format on the TTIP and TRING pins after pulse shaping. The Single-Rail Mode Select Register ([SRMS](#)) is used for selection of dual-rail or single-rail mode. The data that arrives at the TPOS can be overwritten in the maintenance mode by setting in Bit Error Rate Tester Control Register ([BTCR](#)).

5.4.5 Zero Suppression—B8ZS or HDB3

B8ZS coding is available when the device is in T1 mode (selected by TS2, TS1 and TS0 bits in the [TS](#) register). B8ZS/HDB3 coding are enabled by default in single-rail mode. Setting the LCS bit in the [LCS](#) Register disables B8ZS/HDB3. Note that if the individual LIU is configured in E1 mode then HDB3 code substitution will be selected. Bipolar violations can be inserted via the [BEIR](#) register only if B8ZS or HDB3 coding is turned off.

B8ZS substitution is defined in ANSI T1.102 and HDB3 in ITU-T G.703 standards.

5.4.6 Transmit Power-Down

The transmitter will be powered down if the relevant bits in the [TPDE](#) are set. The TTIP/TRING outputs will be high impedance when TPDE is set.

5.4.7 Transmit All Ones

When Transmit All Ones is invoked, continuous ones are transmitted using MCLK as the timing reference. Data input at TPOS and TNEG is ignored.

Transmit All Ones can be sent by setting bits in the [TAOE](#) Register. Also, Transmit All Ones will be enabled if bits in [ATAOS](#) are set and the corresponding receiver goes into LOS state in status register [LOSS](#).

5.4.8 Driver Fail Monitor

The Driver Fail Monitor is connected to the TTIP and TRING pins. It will detect a short or open circuit on the secondary side of the transmit transformer. The drive current will be limited to 50mA if a short circuit is detected. The [DFMS](#) status registers and the corresponding interrupt and enable registers can be used to monitor the driver failure.

5.5 Receiver

The DS26324's 16 receivers are all identical. A 1:2 or 1:1 transformer can be used on the receive side (selected by the RTR bit), but only a 1:1 transformer can be used if fully internal impedance match is enabled. Fully internal receive impedance match does not require the use of any external resistor on the receive line. If partially internal impedance matching is selected, the DS26324 will need only an external 120Ω resistor (30Ω for a 1:2 transformer) for E1, T1, and J1. The receive impedance match settings are controlled by the transmit template/impedance selection. See [Figure 5-8](#) and [Table 5-5](#) for external component values. Partially internal impedance matching is enabled via the [TS.RIMPON](#) bit. Fully internal impedance matching is enabled by setting [GC.RIMPMS](#) and [TS.RIMPON](#).

The peak detector and data slicer process the received signal. The output of the data slicer goes to clock and data recovery. A 2.048/1.544 PLL is internally multiplied by 16 via another internal PLL and fed to the clock recovery system derives E1 or T1 clock. The clock recovery system uses the clock from the PLL circuit to form a 16 times oversampler, which is used to recover the clock and data. This oversampling technique offers outstanding performance to meet jitter tolerance specifications.

B8ZS/HDB3/AMI decoding is available when single-rail mode is selected. The selection of single-rail or dual rail is done by settings in the [SRMS](#) register.

The receiver is capable of recovering signals up to 18dB worth of attenuation. The receiver contains functionality to provide resistive gain up to 20dB for monitor mode.

Three receive termination modes are available:

- 1) **External Impedance Matching.** Internal impedance matching is disabled, external resistor should match line impedance.
- 2) **Partially Internal Impedance Matching.** Internal impedance matching is enabled, in parallel with an external termination resistor (one value for all terminations).
- 3) **Fully Internal Impedance Matching.** Internal impedance matching is enabled, no external termination necessary. This mode requires a 1:1 receive-side transformer.

5.5.1 Receiver Impedance Matching Calibration

In fully internal impedance matching mode, calibration of the internal resistors is necessary to match the line impedance accurately. Calibration must be done upon power-up of the device. The resistance of the internal resistors does vary across temperature. Therefore, it may be necessary to recalibrate if the ambient temperature changes more than 30°C. The user may conclude that it is necessary to recalibrate on a periodic basis if he expects such temperature swings. Calibration is not necessary for partially internal impedance match mode.

5.5.2 Receiver Monitor Mode

The receive equalizer is equipped with monitor mode function that allows for resistive gain up to 20dB, along with cable attenuation of 6dB to 24dB as shown in the [RSMM1–4](#) registers.

5.5.3 Peak Detector and Slicer

The slicer determines the polarity and presence of the received data. The output of the slicer is sent to the clock and data recovery circuitry for extraction of data and clock. The slicer has a built-in peak detector for determination of the slicing threshold.

5.5.4 Receive Level Indicator

The DS26324 will report the signal strength at RTIP and RRING in increments described in [Table 6-17](#), via register bits CnRL3–CnRL0 located in the [RSL1–4](#) registers.

5.5.5 Clock and Data Recovery

The resultant E1 or T1 clock derived from the 2.048/1.544 PLL is internally multiplied by 16 via another internal PLL and fed to the clock recovery system. The clock recovery system uses the clock from the PLL circuit to form a 16 times oversampler, which is used to recover the clock and data. This oversampling technique offers outstanding performance to meet jitter tolerance specifications.

5.5.6 Loss of Signal

The DS26324 uses both the digital and analog loss-detection method in compliance with the latest ANSI T1.231 for T1/J1 and ITU-T G.775 or ETS 300 233 for E1 mode of operation.

LOS is detected if the receiver level falls below a threshold analog voltage for certain duration. Alternatively, this can be termed as having received “zeros” for certain duration. The signal level and timing duration are defined in accordance with the ANSI T1.231, ITU-T G.775, or ETS 300 233 specifications.

The loss detection thresholds are based on cable loss of 18dB for both T1 and E1 modes.

RCLK is replaced by MCLK when the receiver detects a loss of signal. If the AISEL bit is set in the [GC](#) register or the [IAISEL](#) bit is set, the RPOS/RNEG data is replaced by AIS. The loss state is exited when the receiver detects a certain number of ones density at a higher signal level than the loss detection level. The loss detection signal level and loss reset signal level are defined with a hysteresis to prevent the receiver from bouncing between “LOS” and “no LOS” states.

[Table 5-6](#) outlines the specifications governing the loss function.

Table 5-6. Loss Criteria ANSI T1.231, ITU-T G.775, and ETS 300 233 Specifications

CRITERIA	STANDARD		
	T1.231	ITU-T G.775	ETS 300 233
Loss Detection Criteria	No pulses are detected for 175 ±75 bits.	No pulses are detected for duration of 10 to 255 bit periods.	No pulses are detected for a duration of 2048 bit periods or 1ms.
Loss Reset Criteria	Loss is terminated if a duration of 12.5% ones are detected over duration of 175 ±75 bits. Loss is not terminated if 8 consecutive zeros are found if B8ZS encoding is used. If B8ZS is not used loss is not terminated if 100 consecutive pulses are zero.	The incoming signal has transitions for duration of 10 to 255 bit periods.	Loss reset criteria is not defined.

5.5.6.1 ANSI T1.231 for T1 and J1 Modes

Loss is detected if the received signal level is less than 200mV for duration of 192 bit periods. LOS is reset if the all of the following criteria are met:

- 24 or more ones are detected in 192-bit period with a detection threshold of 300mV measured at RTIP and RRING.
- During the 192 bits less than 100 consecutive zeros are detected.
- 8 consecutive zeros are not detected if B8ZS is set.

5.5.6.2 ITU-T G.775 for E1 Modes

LOS is detected if the received signal level is less than 200mV for a continuous duration of 192 bit periods. LOS is reset if the receive signal level is greater than 300mV for a duration of 192 bit periods.

5.5.6.3 ETS 300 233 for E1 Modes

LOS is detected if the received signal level is less than 200mV for a continuous duration of 2048 (1ms) bit periods. LOS is reset if the receive signal level is greater than 300mV for a duration of 192 bit periods.

5.5.7 AIS

[Table 5-7](#) outlines the DS26324 AIS related specifications. [Table 5-8](#) states the AIS functionality in the DS26324. The registers related to the AIS detection are shown in [Table 5-9](#).

Table 5-7. AIS Criteria ANSI T1.231, ITU-T G.775, and ETS 300 233 Specifications

CRITERIA	STANDARD		
	ITU-T G.775 for E1	ETS 300 233 for E1	ANSI T1.231 for T1
AIS Detection Criteria	2 or fewer zeros in each of 2 consecutive 512-bit stream received.	Fewer than 3 zeros detected in 512 bit period.	Fewer than 9 zeros detected in a 8192-bit period (a ones density of 99.9% over a period of 5.3ms) are received.
AIS Clearance Criteria	3 or more zeros in each of 2 consecutive 512-bit streams received.	3 or more zeros in 512 bits received.	9 or more zeros detected in a 8192-bit period are received.

Table 5-8. AIS Detection and Reset Criteria for DS26324

CRITERIA	STANDARD		
	ITU-T G.775 for E1	ETS 300 233 for E1	ANSI T1.231 for T1
AIS Detection Criteria	2 or fewer zeros in each of 2 consecutive 512-bit streams received.	Fewer than 3 zeros detected in 512-bit period.	Fewer than 9 zeros contained in 8192 bits.
AIS Clearance Criteria	3 or more zeros in each of 2 consecutive 512-bit streams received.	3 or more zeros in 512 bits received.	9 or more bits received in a 8192-bit stream.

Table 5-9. Registers Related to AIS Detection

REGISTER	NAME	FUNCTIONALITY
LOS/AIS Criteria Selection	LASCS	Section criteria for AIS (T1.231, G.775, ETS 300 233 for E1).
Alarm Indication Signal Status	AIS	Set when AIS is detected.
AIS Interrupt Enable	AISIE	If reset, interrupt due to AIS is not generated.
AIS Interrupt Status	AISIS	Latched if there is a change in AIS and the interrupt is enabled.

5.5.8 Receive Dual-Rail Mode

Receive dual-rail mode consists of the RPOS, RNEG, and RCLK pins on the system side. In receive dual-rail mode, B8ZS and HDB3 decoding is not available. The data that appears on the RTIP and RRING pins is output on RPOS and RNEG without any modification. The Single-Rail Mode Select Register ([SRMS](#)) is used for selection of

dual-rail or single-rail mode. The bipolar violation (and B8ZS/HDB3) detectors detect violations in dual-rail and single-rail modes, but in dual-rail mode the violations will only be reported to the Line Violation Detect Status (LVDS) registers.

5.5.9 Receive Single-Rail Mode

Receive single-rail mode consists of the RPOS, RCLK, and CV pins on the system side. B8ZS or HDB3 decoding is available. The Single-Rail Mode Select Register (SRMS) is used for selection of dual-rail or single-rail mode.

5.5.10 Bipolar Violation and Excessive Zero Detector

The DS26324 detects HDB3 code violations, BPVs, and excessive zero errors. The reporting of the errors is done through the RNEGn/CVn pin in single-rail mode and the LVDS registers in both single- and dual-rail modes. Code violations are only detected in E1 mode with HDB3 encoding. The code violation detection declares an error when a bipolar violation of the same polarity as the last bipolar violation is received.

Excessive zeros are detected if eight consecutive zeros are detected with B8ZS enabled and four consecutive zeros are detected with HDB3 enabled. Excessive zero detection is enabled via the Excessive Zero Detect Enable Register (EZDE) and when HDB3/B8ZS encoding/decoding is selected via the Line Code Selection Register (LCS).

The bits in the LCS, EZDE, and CVDEB registers determine the combinations that are reported. Table 5-10 outlines the functionality.

Table 5-10. BPV, Code Violation, and Excessive Zero Error Reporting

CONDITIONS			ERRORS DETECTED
LCS	EZDE	CVDEB	
0	0	0	BPV (T1)/Code Violation (E1)
0	0	1	BPV
0	1	0	Excessive Zeros and BPV (T1)/Code Violation (E1)
0	1	1	Excessive Zeros and BPV
1	X	X	BPV

5.6 Jitter Attenuator

The DS26324 contains an on-board jitter attenuator that can be set to a depth of either 32 or 128 bits via the JADS bit in register [GC](#). It can also be controlled on an individual LIU basis by settings in the [IJAFDS](#) register.

The 128-bit mode is used in applications where large excursions of wander are expected. The 32-bit mode is used in delay sensitive applications. The characteristics of the attenuation are shown in [Figure 5-9](#). The jitter attenuator can be placed in either the receive path or the transmit path or none by appropriately setting the JAPS and the JAE bits in register [GC](#). These selections can be changed on an individual LIU basis by settings in the [IJAPS](#) and [IJAE](#).

In order for the jitter attenuator to operate properly, a 2.048MHz clock or multiple thereof, or 1.544MHz clock or multiple thereof, must be applied at MCLK. ITU-T specification G.703 requires an accuracy of ± 50 ppm for both T1 and E1 applications. AT&T Pub 62411 and ANSI specs require an accuracy of ± 32 ppm for T1 interfaces. On-board circuitry adjusts either the recovered clock from the clock/data recovery block or the clock applied at the TCLK pin to create a smooth jitter-free clock, which is used to clock data out of the jitter attenuator FIFO. It is acceptable to provide a jittery clock at the TCLK pin if the jitter attenuator is placed on the transmit side. If the incoming jitter exceeds either $120\text{UI}_{\text{P-P}}$ (buffer depth is 128 bits) or $28\text{UI}_{\text{P-P}}$ (buffer depth is 32 bits), the DS26324 will divide the internal nominal 32.768MHz (E1) or 24.704MHz (T1) clock by either 15 or 17 instead of the normal 16 to keep the buffer from overflowing. When the device divides by either 15 or 17, it also sets the jitter attenuator limit trip (IJAFLT) bits in the [IJAFLT](#) register described.

Figure 5-9. Jitter Attenuation

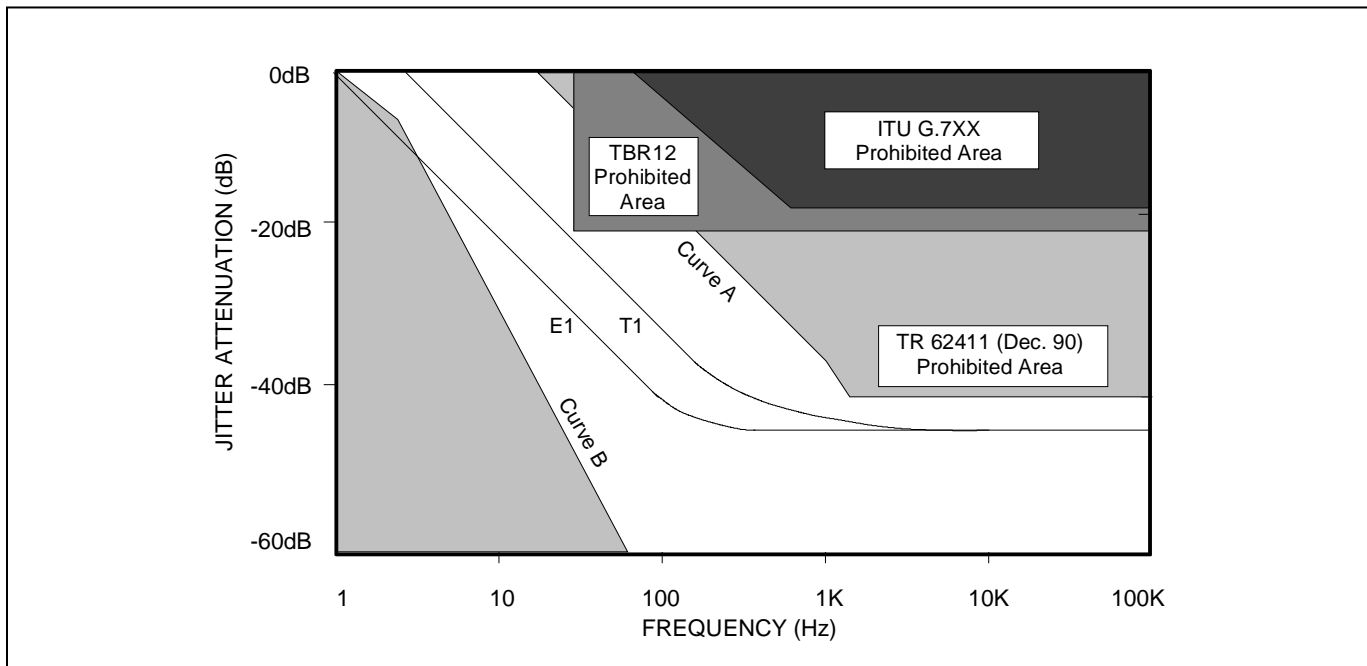

5.7 G.772 Monitor

In this application, only 14 transceivers are functional and two transceivers are used for nonintrusive monitoring of input and output of the other 14 channels. Channel 9 is used for 10 to 16 channels and Channel 1 is used for 2 to 8 channels. G.772 monitoring is configured by the BERT and G.772 Monitoring Control Register (BGMC) (see [Table 6-9](#)). While monitoring, Channel 1 can be configured in remote loopback and the monitored signal can be output on TTIP1 and TRING1. While monitoring, Channel 9 can be configured in remote loopback and the monitored signal can be output on TTIP9 and TRING9.

5.8 Loopbacks

The DS26324 provides four loopbacks for diagnostic purposes: analog loopback, digital loopback, remote loopback, and dual loopback. Dual loopback is accomplished by turning on digital loopback and remote loopback at the same time.

5.8.1 Analog Loopback

The analog output of the transmitter TTIP and TRING is looped back to RTIP and RRING of the receiver. Data at RTIP and RRING is ignored in analog loopback. This is shown in [Figure 5-10](#).

Figure 5-10. Analog Loopback

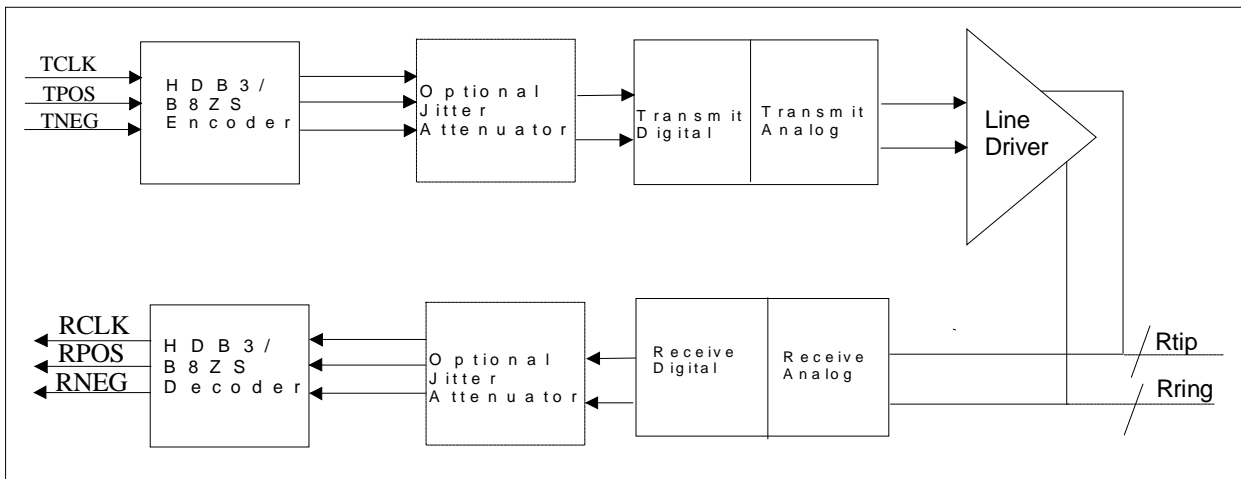

5.8.2 Digital Loopback

The transmit system data TPOS, TNEG, and TCLK will be looped back to output on RCLK, RPOS, and RNEG. The data input at TPOS and TNEG is output on TTIP and TRING. All ones can also be output when selected by the Transmit All Ones Enable Register (TAOE). Signals at RTIP and RRING will be ignored. This loopback is conceptually shown in [Figure 5-11](#).

Figure 5-11. Digital Loopback

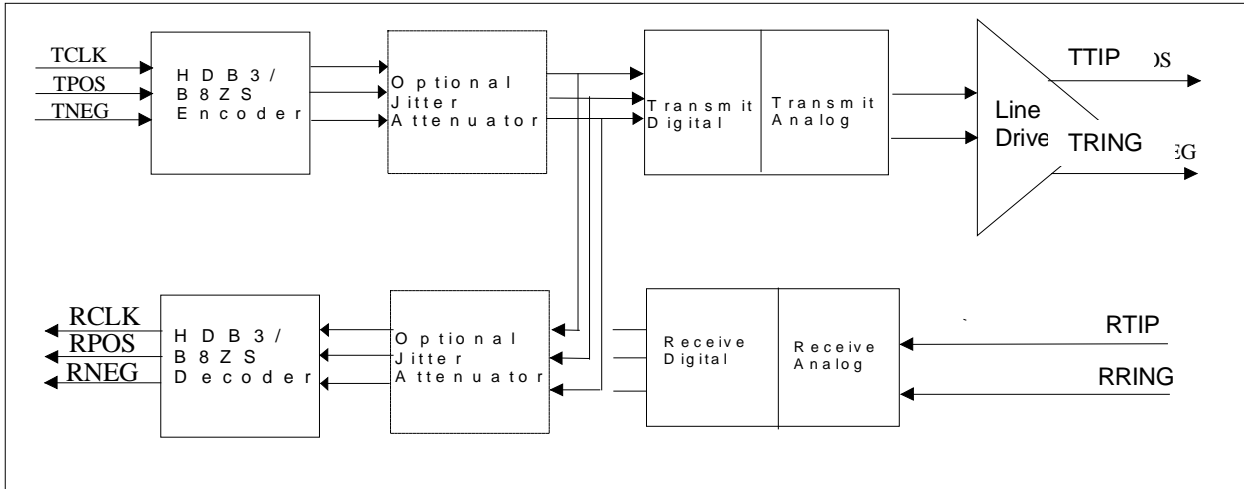

5.8.3 Remote Loopback

The inputs at RTIP and RRING are looped back to TTIP and TRING. The inputs at TCLK, TPOS, and TNEG are ignored during a remote loopback. This loopback is conceptually shown in [Figure 5-12](#).

Note: Remote loopback does not take precedence over transmit power-down and requires TCLK to operate. The transmitters will use the recovered RCLK in remote loopback. TCLK is still required because if it is removed the transmitters will power-down (TCLK held low) or transmit all ones (TCLK held high).

Figure 5-12. Remote Loopback

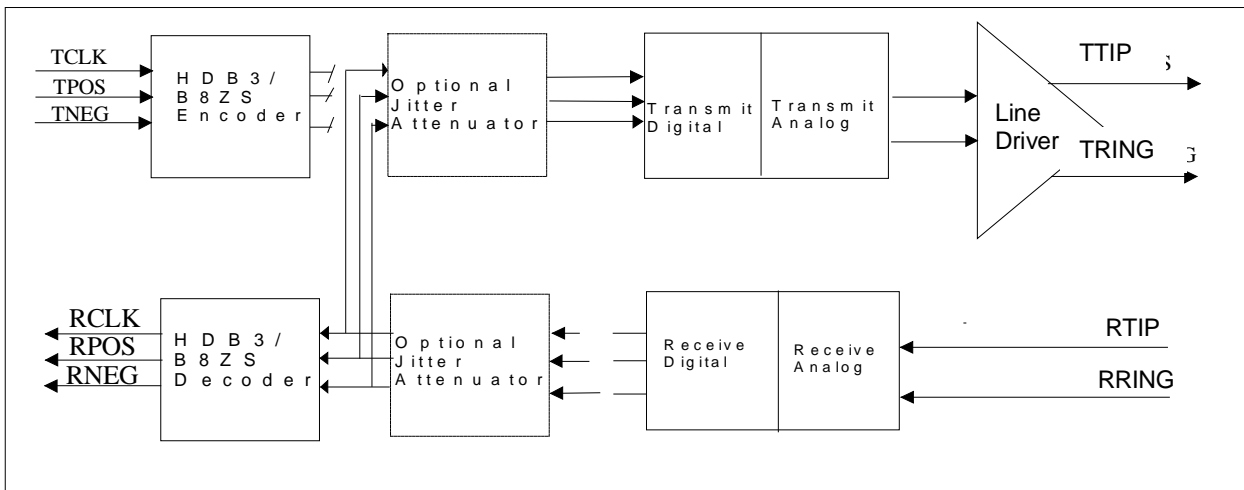

5.9 BERT

There are two bit error-rate testers available on the DS26324. One BERT can be mapped into LIUs 1–8 and the other into LIUs 9–16 via the [BTCR](#) registers. The two BERTs operate independently of each other.

Each BERT transmitter, by default, replaces data from TPOS and TNEG; each BERT receiver, by default, samples recovered data from RTIP and RRING.

The BERT can be enabled to replace data received on RTIP and RRING via the BERTDIR bit in the BERT and G.772 Monitoring Control Register ([BGMC](#)). In this mode, the SRMS bit determines whether data comes out single-rail or dual-rail. BERT data can be sourced using the recovered clock, MCLK, or TCLK. In this mode of operation, the BERT receiver samples data on TPOS and TNEG on the falling edge of TCLK. This function is useful for testing the digital side of the LIU. If TCLK is selected as a source for this mode, the input TCLK will control the BERT transmitter and receiver. If the recovered clock or MCLK is selected, the RCLK output needs to drive the TCLK input in order for the BERT receiver to sync to the data.

5.9.1 General Description

The BERT is a software-programmable test pattern generator and monitor capable of meeting most error performance requirements for digital transmission equipment. It will generate and synchronize to pseudorandom patterns with a generation polynomial of the form $x^n + x^y + 1$, where n and y can take on values from 1 to 32 and repetitive patterns of any length up to 32 bits.

The transmit direction generates the programmable test pattern, and inserts the test pattern payload into the data stream.

The receive direction extracts the test pattern payload from the receive data stream, and monitors the test pattern payload for the programmable test pattern.

5.9.1.1 BERT Features

- **Programmable PRBS Pattern.** The pseudorandom bit sequence (PRBS) polynomial ($x^n + x^y + 1$) and seed are programmable (length $n = 1$ to 32, tap $y = 1$ to $n - 1$, and seed = 0 to $2^n - 1$).
- **Programmable Repetitive Pattern.** The repetitive pattern length and pattern are programmable (the length $n = 1$ to 32 and pattern = 0 to $2^n - 1$).
- **24-Bit Error Count and 32-Bit Bit Count Registers**
- **Programmable Bit-Error Insertion.** Errors can be inserted individually, on a pin transition, or at a specific rate. The rate $1/10^n$ is programmable ($n = 1$ to 7).
- **Pattern Synchronization at a 10^{-3} BER.** Pattern synchronization is achieved even in the presence of a random bit error rate (BER) of 10^{-3} .

5.9.2 Configuration and Monitoring

Set [BPCR.BERTE](#) = 1 to enable the BERT. The following tables show how to configure the on-board BERT to send and receive common patterns.

Table 5-11. Pseudorandom Pattern Generation

PATTERN TYPE	BPCR REGISTER				BERT.PCR	BERT.SPR2	BERT.SPR1	BERT.CR
	PTF[4:0] (hex)	PLF[4:0] (hex)	PTS	QRSS				TPIC, RPIC
2 ⁹ -1 O.153 (511 type)	04	08	0	0	0x0408	0xFFFF	0xFFFF	0
2 ¹¹ -1 O.152 and O.153 (2047 type)	08	0A	0	0	0x080A	0xFFFF	0xFFFF	0
2 ¹⁵ -1 O.151	0D	0E	0	0	0x0D0E	0xFFFF	0xFFFF	1
2 ²⁰ -1 O.153	10	13	0	0	0x1013	0xFFFF	0xFFFF	0
2 ²⁰ -1 O.151 QRSS	02	13	0	1	0x0253	0xFFFF	0xFFFF	0
2 ²³ -1 O.151	11	16	0	0	0x1116	0xFFFF	0xFFFF	1

Table 5-12. Repetitive Pattern Generation

PATTERN TYPE	BPCR REGISTER				BERT.PCR	BERT.SPR2	BERT.SPR1
	PTF[4:0] (hex)	PLF[4:0] (hex)	PTS	QRSS			
All Ones	NA	00	1	0	0x0020	0xFFFF	0xFFFF
All Zeros	NA	00	1	0	0x0020	0xFFFF	0xFFFE
Alternating Ones and Zeros	NA	01	1	0	0x0021	0xFFFF	0xFFFE
Double Alternating and Zeros	NA	03	1	0	0x0023	0xFFFF	0xFFFC
3 in 24	NA	17	1	0	0x0037	0xFF20	0x0022
1 in 16	NA	0F	1	0	0x002F	0xFFFF	0x0001
1 in 8	NA	07	1	0	0x0027	0xFFFF	0xFF01
1 in 4	NA	03	1	0	0x0023	0xFFFF	0xFFF1

After configuring these bits, the pattern must be loaded into the BERT. This is accomplished via a zero-to-one transition on [BCR.TNPL](#) and [BCR.RNPL](#).

Monitoring the BERT requires reading the [BSR](#) register, which contains the Bit Error Count (BEC) bit and the Out of Synchronization (OOS) bit. The BEC bit will be one when the bit error counter is one or more. The OOS will be one when the receive pattern generator is not synchronized to the incoming pattern, which will occur when it receives a minimum 6 bit errors within a 64-bit window. The Receive BERT Bit Count Register ([RBCR](#)) and the Receive BERT Bit Error Count Register ([RBECCR](#)) will be updated upon the reception of a Performance Monitor Update signal (e.g., [BCR.LPMU](#)). This signal will update the registers with the values of the counters since the last update and will reset the counters.

5.9.3 Receive Pattern Detection

The Receive BERT receives only the payload data and synchronizes the receive pattern generator to the incoming pattern. The receive pattern generator is a 32-bit shift register that shifts data from the least significant bit (LSB) or bit 1 to the most significant bit (MSB) or bit 32. The input to bit 1 is the feedback. For a PRBS pattern (generating polynomial $x^n + x^y + 1$), the feedback is an XOR of bit n and bit y . For a repetitive pattern (length n), the feedback is bit n . The values for n and y are individually programmable (1 to 32). The output of the receive pattern generator is the feedback. If QRSS is enabled, the feedback is an XOR of bits 17 and 20, and the output will be forced to one if the next 14 bits are all zeros. QRSS is programmable (on or off). For PRBS and QRSS patterns, the feedback will be forced to one if bits 1 through 31 are all zeros. Depending on the type of pattern programmed, pattern detection performs either PRBS synchronization or repetitive pattern synchronization.

5.9.3.1 Receive PRBS Synchronization

PRBS synchronization synchronizes the receive pattern generator to the incoming PRBS or QRSS pattern. The receive pattern generator is synchronized by loading 32 data stream bits into the receive pattern generator, and then checking the next 32 data stream bits. Synchronization is achieved if all 32 bits match the incoming pattern. If at least six incoming bits in the current 64-bit window do not match the receive pattern generator, automatic pattern re-synchronization is initiated. Automatic pattern re-synchronization can be disabled.

See [Figure 5-13](#) for the PRBS synchronization diagram.

Figure 5-13. PRBS Synchronization State Diagram

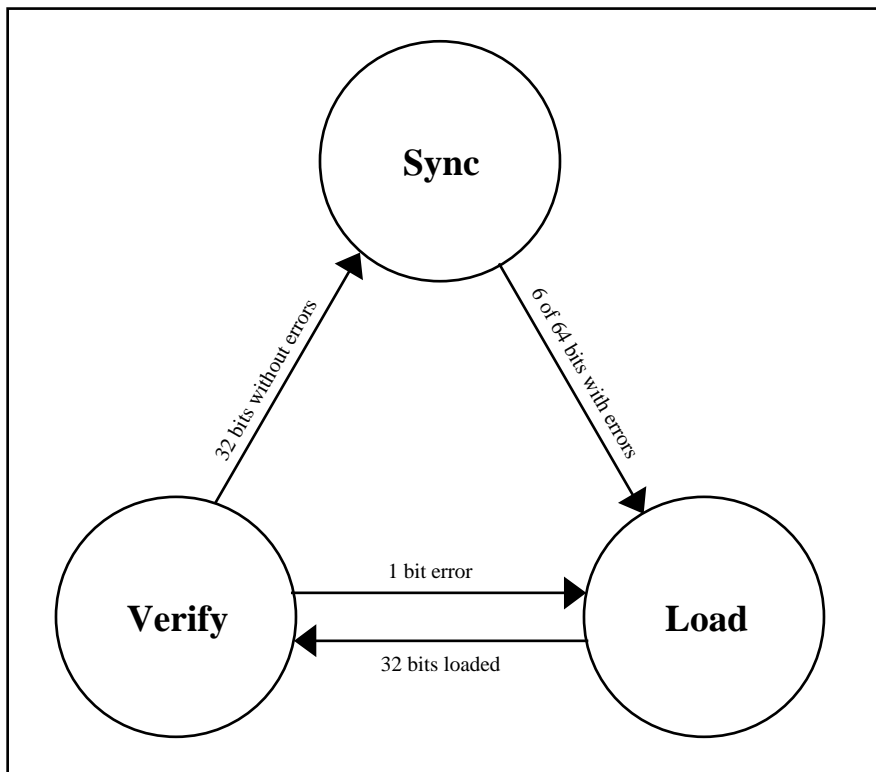

5.9.3.2 Receive Repetitive Pattern Synchronization

Repetitive pattern synchronization synchronizes the receive pattern generator to the incoming repetitive pattern. The receive pattern generator is synchronized by searching each incoming data stream bit position for the repetitive pattern, and then checking the next 32 data stream bits. Synchronization is achieved if all 32 bits match the incoming pattern. If at least six incoming bits in the current 64-bit window do not match the receive PRBS pattern generator, automatic pattern re-synchronization is initiated. Automatic pattern re-synchronization can be disabled.

See [Figure 5-14](#) for the repetitive pattern synchronization state diagram.

Figure 5-14. Repetitive Pattern Synchronization State Diagram

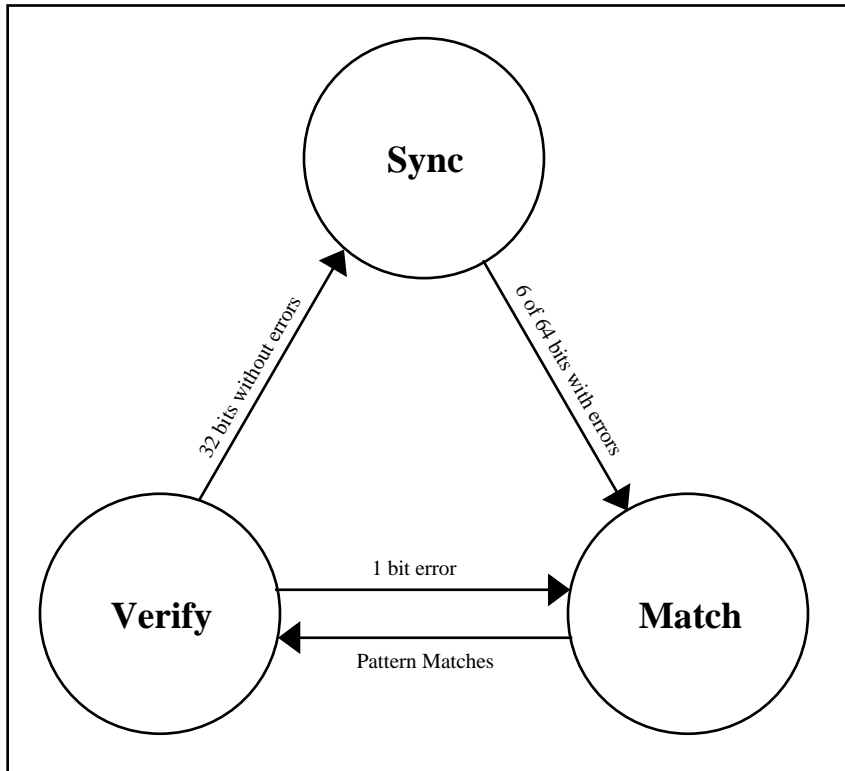

5.9.3.3 Receive Pattern Monitoring

Receive pattern monitoring monitors the incoming data stream for both an OOS condition and bit errors and counts the incoming bits. An Out Of Synchronization (OOS) condition is declared when the synchronization state machine is not in the "Sync" state. An OOS condition is terminated when the synchronization state machine is in the "Sync" state.

Bit errors are determined by comparing the incoming data stream bit to the receive pattern generator output. If they do not match, a bit error is declared, and the bit error and bit counts are incremented. If they match, only the bit count is incremented. The bit count and bit error count are not incremented when an OOS condition exists.

5.9.4 Transmit Pattern Generation

Pattern generation generates the outgoing test pattern, and passes it onto error insertion. The transmit pattern generator is a 32-bit shift register that shifts data from the least significant bit (LSB) or bit 1 to the most significant bit (MSB) or bit 32. The input to bit 1 is the feedback. For a PRBS pattern (generating polynomial $x^n + x^y + 1$), the feedback is an XOR of bit n and bit y . For a repetitive pattern (length n), the feedback is bit n . The values for n and y are individually programmable (1 to 32). The output of the receive pattern generator is the feedback. If QRSS is enabled, the feedback is an XOR of bits 17 and 20, and the output will be forced to one if the next 14 bits are all zeros. QRSS is programmable (on or off). For PRBS and QRSS patterns, the feedback will be forced to one if bits 1 through 31 are all zeros. When a new pattern is loaded, the pattern generator is loaded with a seed/pattern value before pattern generation starts. The seed/pattern value is programmable ($0 - 2^n - 1$).

5.9.4.1 Transmit Error Insertion

Error insertion inserts errors into the outgoing pattern data stream. Errors are inserted one at a time or at a rate of one out of every 10^n bits. The value of n is programmable (1 to 7 or off). Single bit error insertion can be initiated from the microprocessor interface, or by the manual error insertion input (TMEI). The method of single error insertion is programmable (register or input). If pattern inversion is enabled, the data stream is inverted before the overhead/stuff bits are inserted. Pattern inversion is programmable (on or off).

6 REGISTER MAPS AND DEFINITION

Six address bits are used to control the settings of the registers. In the parallel nonmultiplexed mode address [5:0] is used. In multiplexed mode AD[5:0] is used and A[6:1] is used in the serial mode. The register space contains two independent sets of registers. The lower set of registers (LIUs 1–8) is located from address 00 hex to 1F hex and contains controls for LIUs 1–8. The upper set of registers (LIUs 9–16) is a duplicate of the lower set, located from address 20 hex to 3F hex that controls LIUs 9–16. Each of these sets of registers consists of four banks: Primary, Secondary, Individual LIU, and BERT.

The [ADDP](#) register for the lower set of registers (LIUs 1–8) is located at address 1F hex. This register is used as a pointer to access the 4 banks of registers in the lower (LIUs 1–8) register set. Similarly, the [ADDP](#) register for the upper set of registers (LIUs 9–16) is located at address 3F hex. This register is used as a pointer to access the four banks of registers in the upper (LIUs 9–16) register set. Setting an [ADDP](#) register to AA hex will access the secondary bank of registers, 01 hex will access the Individual LIU bank of registers, 02 hex will access the BERT bank of registers, and 00 hex (default on power-up) will access the Primary bank of registers. Note that bank selection for the lower set of registers (LIUs 1–8) is controlled only by the ADDP at 1F hex and that bank selection for the upper set of registers (LIUs 9–16) is controlled only by the ADDP at 3F hex.

Table 6-1. Primary Register Set

REGISTER	NAME	HEX FOR CH 1–8	ADDRESS FOR CH 1–8		HEX FOR CH 9–16	ADDRESS FOR CH 9–16		RW
			PARALLEL INTERFACE A[7:0] (HEX)	SERIAL INTERFACE A[7:1] (HEX)		PARALLEL INTERFACE A[7:0] (HEX)	SERIAL INTERFACE A[7:1] (HEX)	
Identification	ID	00	xx000000	x000000	20	Not used	Not used	R
Analog Loopback Control	ALBC	01	xx000001	x000001	21	xx100001	x100001	RW
Remote Loopback Control	RLBC	02	xx000010	x000010	22	xx100010	x100010	RW
Transmit All Ones Enable	TAOE	03	xx000011	x000011	23	xx100011	x100011	RW
Loss of Signal Status	LOSS	04	xx000100	x000100	24	xx100100	x100100	R
Driver Fault Monitor Status	DFMS	05	xx000101	x000101	25	xx100101	x100101	R
Loss of Signal Interrupt Enable	LOSIE	06	xx000110	x000110	26	xx100110	x100110	RW
Driver Fault Monitor Interrupt Enable	DFMIE	07	xx000111	x000111	27	xx100111	x100111	RW
Loss of Signal Interrupt Status	LOSIS	08	xx001000	x001000	28	xx101000	x101000	R
Driver Fault Monitor Interrupt Status	DFMIS	09	xx001001	x001001	29	xx101001	x101001	R
Software Reset	SWR	0A	xx001010	x001010	2A	xx101010	x101010	W
BERT and G.772 Monitoring Control	BGMC	0B	xx001011	x001011	2B	xx101011	x101011	RW
Digital Loopback Control	DLBC	0C	xx001100	x001100	2C	xx101100	x101100	RW
LOS/AIS Criteria Selection	LASCS	0D	xx001101	x001101	2D	xx101101	x101101	RW
Automatic Transmit All Ones Select	ATAOS	0E	xx001110	x001110	2E	xx101110	x101110	RW
Global Configuration	GC	0F	xx001111	x001111	2F	xx101111	x101111	RW
Template Select Transmitter	TST	10	xx010000	x010000	30	xx110000	x110000	RW
Template Select	TS	11	xx010001	x010001	31	xx110001	x110001	RW
Output Enable Configuration	OE	12	xx010010	x010010	32	xx110010	x110010	RW
Alarm Indication Signal Status	AIS	13	xx010011	x010011	33	xx110011	x110011	R
AIS Interrupt Enable	AISIE	14	xx010100	x010100	34	xx110100	x110100	RW
AIS Interrupt Status	AISIS	15	xx010101	x010101	35	xx110101	x110101	R
Reserved	—	16–1E	xx010110– xx011110	x010110– x011110	36–3E	xx110110– x111110	x110110– x111110	—
Address Pointer for Bank Selection	ADDP	1F	xx011111	x011111	3F	xx111111	x111111	RW

Table 6-2. Secondary Register Set

REGISTER	NAME	HEX FOR CH 1–8	ADDRESS FOR CHANNELS 1–8		HEX FOR CH 9–16	ADDRESS FOR CHANNELS 9–16		RW
			PARALLEL INTERFACE A[7:0] (HEX)	SERIAL INTERFACE A[7:1] (HEX)		PARALLEL INTERFACE A[7:0] (HEX)	SERIAL INTERFACE A[7:1] (HEX)	
Single-Rail Mode Select	SRMS	00	xx000000	x000000	20	xx100000	x100000	RW
Line Code Selection	LCS	01	xx000001	x000001	21	xx100001	x100001	R
Not Used	—	02	xx000010	x000010	22	xx100010	x100010	R
Receive Power-Down Enable	RPDE	03	xx000011	x000011	23	xx100011	x100011	RW
Transmit Power-Down Enable	TPDE	04	xx000100	x000100	24	xx100100	x100100	RW
Excessive Zero Detect Enable	EZDE	05	xx000101	x000101	25	xx100101	x100101	R
Code Violation Detect Enable Bar	CVDEB	06	xx000110	x000110	26	xx100110	x100110	R
Not Used	—	07–1E	xx000111– xx011110	x000111– x011110	27–3E	xx100111– xx111110	x100111– x111110	W
Address Pointer for Bank Selection	ADDP	1F	xx011111	x011111	3F	xx111111	x111111	RW

Table 6-3. Individual LIU Register Set

REGISTER	NAME	HEX FOR CH 1–8	ADDRESS FOR CHANNELS 1–8		HEX FOR CH 9–16	ADDRESS FOR CHANNELS 9–16		RW
			PARALLEL INTERFACE A[7:0] (HEX)	SERIAL INTERFACE A[7:1] (HEX)		PARALLEL INTERFACE A[7:0] (HEX)	SERIAL INTERFACE A[7:1] (HEX)	
Individual Jitter Attenuator Enable	IJAЕ	00	xx000000	x000000	20	xx100000	x100000	RW
Individual Jitter Attenuator Position Select	IJAPS	01	xx000001	x000001	21	xx100001	x100001	RW
Individual Jitter Attenuator FIFO Depth Select	IJAFDS	02	xx000010	x000010	22	xx100010	x100010	RW
Individual Jitter Attenuator FIFO Limit Trip	IJAFLT	03	xx000011	x000011	23	xx100011	x100011	R
Individual Short-Circuit Protection Disable	ISCPD	04	xx000100	x000100	24	xx100100	x100100	RW
Individual AIS Select	IAISEL	05	xx000101	x000101	25	xx100101	x100101	RW
Master Clock Select	MC	06	xx000110	x000110	26	Not used	Not used	RW
Receive Sensitivity Monitor Mode 1–4	RSMM1 , RSMM2 , RSMM3 , RSMM4	08–0B	xx001000– xx001011	x001000– x001011	28–2B	xx101000– xx101011	x101000– x101011	RW
Receive Signal Level Indicator 1–4	RSL 1–4	0C–0F	xx001100– xx001111	x001100– x001111	2C–2F	xx101100– xx101111	x101100– x101111	R
Bit Error Rate Tester Control	BTCR	10	xx010000	x010000	30	xx110000	x110000	RW
Line Violation Detect Status	LVDS	12	xx010010	x010010	32	xx110010	x110010	R
Receive Clock Invert	RCLKI	13	xx010011	x010011	33	xx110011	x110011	RW
Transmit Clock Invert	TCLKI	14	xx010100	x010100	34	xx110100	x110100	RW
Clock Control Register	CCR	15	xx010101	x010101	35	Not used	Not used	RW
RCLK Disable Upon LOS	RDULR	16	xx010110	x010110	36	xx110110	x110110	RW
Global Interrupt Status Control	GISC	1E	xx011110	x011110	3E	Not used	Not used	RW
Address Pointer for Bank Selection	ADDP	1F	xx011111	x011111	3F	xx111111	x111111	RW

Table 6-4. BERT Register Set

REGISTER	NAME	HEX FOR CH 1–8	ADDRESS FOR CHANNELS 1–8		HEX FOR CH 9–16	ADDRESS FOR CHANNELS 9–16		RW
			PARALLEL INTERFACE A[7:0] (HEX)	SERIAL INTERFACE A[7:1] (HEX)		PARALLEL INTERFACE A[7:0] (HEX)	SERIAL INTERFACE A[7:1] (HEX)	
BERT Control	BCR	00	xx000000	x000000	20	xx100000	x100000	RW
Reserved	—	01	xx000001	x000001	21	xx100001	x100001	—
BERT Pattern Configuration 1	BPCR1	02	xx000010	x000010	22	xx100010	x100010	RW
BERT Pattern Configuration 2	BPCR2	03	xx000011	x000011	23	xx100011	x100011	RW
BERT Seed/Pattern 1	BSPR1	04	xx000100	x000100	24	xx100100	x100100	RW
BERT Seed/Pattern 2	BSPR2	05	xx000101	x000101	25	xx100101	x100101	RW
BERT Seed/Pattern 3	BSPR3	06	xx000110	x000110	26	xx100110	x100110	RW
BERT Seed/Pattern 4	BSPR4	07	xx000111	x000111	27	xx100111	x100111	RW
Transmit Error Insertion Control	TEICR	08	xx001000	x001000	28	xx101000	x101000	RW
Reserved	—	09–0A	xx001001– x001010	—	29–2A	xx101001– x101010	—	—
BERT Status	BSR	0C	xx001100	x001100	2C	xx101100	x101100	R
Reserved	—	0D	xx001101	x001101	2D	xx101101	x101101	—
BERT Status Register Latched	BSRL	0E	xx010011	x010011	2E	xx110011	x110011	RW
BERT Status Register Interrupt Enable	BSRIE	10	xx010000	x010000	30	xx110000	x110000	RW
Reserved	—	11–13	xx010001– xx010011	X010001– x010011	31–33	xx110001– xx110011	x110001– x110011	—
Receive Bit Error Count Register 1	RBECR1	14	xx010100	x010100	34	xx110100	x110100	R
Receive Bit Error Count Register 2	RBECR2	15	xx010101	x010101	35	xx110101	x110101	R
Receive Bit Error Count Register 3	RBECR3	16	xx010110	x010110	36	xx110110	x110110	R
Receive Bit Count Register 1	RBCR1	18	xx011000	x011000	38	xx111000	x111000	R
Receive Bit Count Register 2	RBCR2	19	xx011001	x011001	39	xx111001	x111001	R
Receive Bit Count Register 3	RBCR3	1A	xx011010	x011010	3A	xx111010	x111010	R
Receive Bit Count Register 4	RBCR4	1B	xx011011	x011011	3B	xx111011	x111011	R
Reserved	—	1C–1E	xx011100– xx011110	x011100– x011110	3C–3E	xx111100– xx111110	x111100– x111110	—
Address Pointer for Bank Selection	ADDP	1F	xx011111	x011111	3F	xx111111	x111111	RW

Table 6-5. Primary Register Set Bit Map

REGISTER	ADDRESS FOR LIUs 1-8	R/W	BIT 7	BIT 6	BIT 5	BIT 4	BIT 3	BIT 2	BIT 1	BIT 0
<u>ID</u>	00	R	ID7	ID6	ID5	ID4	ID3	ID2	ID1	ID0
<u>ALBC</u>	01	RW	ALBC8	ALBC7	ALBC6	ALBC5	ALBC4	ALBC3	ALBC2	ALBC1
<u>RLBC</u>	02	RW	RLBC8	RLBC7	RLBC6	RLBC5	RLBC4	RLBC3	RLBC2	RLBC1
<u>TAOE</u>	03	RW	TAOE8	TAOE7	TAOE6	TAOE5	TAOE4	TAOE3	TAOE2	TAOE1
<u>LOSS</u>	04	RW	LOSS8	LOSS7	LOSS6	LOSS5	LOSS4	LOSS3	LOSS2	LOSS1
<u>DFMS</u>	05	RW	DFMS8	DFMS7	DFMS6	DFMS5	DFMS4	DFMS3	DFMS2	DFMS1
<u>LOSIE</u>	06	RW	LOSIE8	LOSIE7	LOSIE6	LOSIE5	LOSIE4	LOSIE3	LOSIE2	LOSIE1
<u>DFMIE</u>	07	RW	DFMIE8	DFMIE7	DFMIE6	DFMIE5	DFMIE4	DFMIE3	DFMIE2	DFMIE1
<u>LOSI8</u>	08	R	LOSI8	LOSI7	LOSI6	LOSI5	LOSI4	LOSI3	LOSI2	LOSI1
<u>DFMIS</u>	09	R	<u>DFMIS8</u>	<u>DFMIS7</u>	<u>DFMIS6</u>	<u>DFMIS5</u>	<u>DFMIS4</u>	<u>DFMIS3</u>	<u>DFMIS2</u>	<u>DFMIS1</u>
<u>SWR</u>	0A	W	SWRL	SWRL	SWRL	SWRL	SWRL	SWRL	SWRL	SWRL
<u>BGMC</u>	0B	RW	BERTDIR	BMCK5	BTCK5	—	GMC4	GMC3	GMC2	GMC1
<u>DLBC</u>	0C	RW	DLBC8	DLBC7	DLBC6	DLBC5	DLBC4	DLBC3	DLBC2	DLBC1
<u>LASCS</u>	0D	RW	LASCS8	LASCS7	LASCS6	LASCS5	LASCS4	LASCS3	LASCS2	LASCS1
<u>ATAOS</u>	0E	RW	ATAOS8	ATAOS7	ATAOS6	ATAOS5	ATAOS4	ATAOS3	ATAOS2	ATAOS1
<u>GC</u>	0F	RW	RIMPMS	AISEL	SCPD	CODE	JADS	CRIMP	JAPS	JAE
<u>TST</u>	10	RW	JABWS1	JABWS0	RHPMC	—	—	TST2	TST1	TST0
<u>TS</u>	11	RW	RIMPON	TIMPOFF	—	—	TIMPRM	TS2	TS1	TS0
<u>OE</u>	12	RW	OE8	OE7	OE6	OE5	OE4	OE3	OE2	OE1
<u>AIS</u>	13	R	<u>AIS8</u>	<u>AIS7</u>	<u>AIS6</u>	<u>AIS5</u>	<u>AIS4</u>	<u>AIS3</u>	<u>AIS2</u>	<u>AIS1</u>
<u>AISIE</u>	14	RW	AISIE8	AISIE7	AISIE6	AISIE5	AISIE4	AISIE3	AISIE2	AISIE1
<u>AISIS</u>	15	R	<u>AISIS8</u>	<u>AISIS7</u>	<u>AISIS6</u>	<u>AISIS5</u>	<u>AISIS4</u>	<u>AISIS3</u>	<u>AISIS2</u>	<u>AISIS1</u>
Not Used	16-1E	—	—	—	—	—	—	—	—	—
<u>ADDP</u>	1F	RW	ADDP7	ADDP6	ADDP5	ADDP4	ADDP3	ADDP2	ADDP1	ADDP0

REGISTER	ADDRESS FOR LIUs 9-16	R/W	BIT 7	BIT 6	BIT 5	BIT 4	BIT 3	BIT 2	BIT 1	BIT 0
Not Used	20	R	—	—	—	—	—	—	—	—
<u>ALBC</u>	21	RW	ALC16	ALBC15	ALBC14	ALBC13	ALBC12	ALBC11	ALBC10	ALBC9
<u>RLBC</u>	22	RW	RLBC16	RLBC15	RLBC14	RLBC13	RLBC12	RLBC11	RLBC10	RLBC9
<u>TAOE</u>	23	RW	TAOE16	TAOE15	TAOE14	TAOE13	TAOE12	TAOE11	TAOE10	TAOE9
<u>LOSS</u>	24	RW	LOSS16	LOSS15	LOSS14	LOSS13	LOSS12	LOSS11	LOSS10	LOSS9
<u>DFMS</u>	25	RW	DFMS16	DFMS15	DFMS14	DFMS13	DFMS12	DFMS11	DFMS10	DFMS9
<u>LOSIE</u>	26	RW	LOSIE16	LOSIE15	LOSIE14	LOSIE13	LOSIE12	LOSIE11	LOSIE10	LOSIE9
<u>DFMIE</u>	27	RW	DFMIE16	DFMIE15	DFMIE14	DFMIE13	DFMIE12	DFMIE11	DFMIE10	DFMIE9
<u>LOSI8</u>	28	R	<u>LOSI16</u>	<u>LOSI15</u>	<u>LOSI14</u>	<u>LOSI13</u>	<u>LOSI12</u>	<u>LOSI11</u>	<u>LOSI10</u>	<u>LOSI9</u>
<u>DFMIS</u>	29	R	<u>DFMIS16</u>	<u>DFMIS15</u>	<u>DFMIS14</u>	<u>DFMIS13</u>	<u>DFMIS12</u>	<u>DFMIS11</u>	<u>DFMIS10</u>	<u>DFMIS9</u>
<u>SWR</u>	2A	W	SWRU	SWRU	SWRU	SWRU	SWRU	SWRU	SWRU	SWRU
<u>BGMC</u>	2B	RW	BERTDIR	BMCK5	BTCK5	—	GMC4	GMC3	GMC2	GMC1
<u>DLBC</u>	2C	RW	DLBC16	DLBC15	DLBC14	DLBC13	DLBC12	DLBC11	DLBC10	DLBC9
<u>LASCS</u>	2D	RW	LASCS16	LASCS15	LASCS14	LASCS13	LASCS12	LASCS11	LASCS10	LASCS9
<u>ATAOS</u>	2E	RW	ATAOS16	ATAOS15	ATAOS14	ATAOS13	ATAOS12	ATAOS11	ATAOS10	ATAOS9
<u>GC</u>	2F	RW	RIMPMS	AISEL	SCPD	CODE	JADS	CALEN	JAPS	JAE
<u>TST</u>	30	RW	—	—	—	—	—	TST2	TST1	TST0
<u>TS</u>	31	RW	RIMPON	TIMPOFF	—	—	TIMPRM	TS2	TS1	TS0
<u>OE</u>	32	RW	OE16	OE15	OE14	OE13	OE12	OE11	OE10	OE9
<u>AIS</u>	33	R	<u>AIS16</u>	<u>AIS15</u>	<u>AIS14</u>	<u>AIS13</u>	<u>AIS12</u>	<u>AIS11</u>	<u>AIS10</u>	<u>AIS9</u>
<u>AISIE</u>	34	RW	AISIE16	AISIE15	AISIE14	AISIE13	AISIE12	AISIE11	AISIE10	AISIE9
<u>AISIS</u>	35	R	<u>AISIS16</u>	<u>AISIS15</u>	<u>AISIS14</u>	<u>AISIS13</u>	<u>AISIS12</u>	<u>AISIS11</u>	<u>AISIS10</u>	<u>AISIS9</u>
Not Used	36-3E	—	—	—	—	—	—	—	—	—
<u>ADDP</u>	3F	RW	ADDP7	ADDP6	ADDP5	ADDP4	ADDP3	ADDP2	ADDP1	ADDP0

Note: Underlined bits are read only.

Table 6-6. Secondary Register Set Bit Map

REGISTER	ADDRESS FOR LIUs 1-8	RW	BIT 7	BIT 6	BIT 5	BIT 4	BIT 3	BIT 2	BIT 1	BIT 0
SRMS	00	RW	SRMS8	SRMS7	SRMS6	SRMS5	SRMS4	SRMS3	SRMS2	SRMS1
LCS	01	RW	LCS8	LCS7	LCS6	LCS5	LSC4	LCS3	LSC2	LSC1
Not Used	02	RW	—	—	—	—	—	—	—	—
RPDE	03	RW	RPDE8	RPDE7	RPDE6	RPDE5	RPDE4	RPDE3	RPDE2	RPDE1
TPDE	04	RW	TPDE8	TDPE7	TPDE6	TPDE5	TPDE4	TPDE3	TPDE2	TPDE1
EZDE	05	RW	EZDE8	EZDE7	EZDE6	EZDE5	EZDE4	EZDE3	EZDE2	EZDE1
CVDEB	06	RW	CVDEB8	CVDEB7	CVDEB6	CVDEB5	CVDEB4	CVDEB3	CVDEB2	CVDEB1
Not Used	07-1E	—	—	—	—	—	—	—	—	—
ADDP	1F	RW	ADDP7	ADDP6	ADDP5	ADDP4	ADDP3	ADDP2	ADDP1	ADDP0

REGISTER	ADDRESS FOR LIUs 9-16	RW	BIT 7	BIT 6	BIT 5	BIT 4	BIT 3	BIT 2	BIT 1	BIT 0
SRMS	20	RW	SRMS16	SRMS15	SRMS14	SRMS13	SRMS12	SRMS11	SRMS10	SRMS9
LCS	21	RW	LCS16	LCS15	LCS14	LCS13	LSC12	LCS11	LSC10	LSC9
Not Used	22	RW	—	—	—	—	—	—	—	—
RPDE	23	RW	RPDE16	RPDE15	RPDE14	RPDE13	RPDE12	RPDE11	RPDE10	RPDE9
TPDE	24	RW	TPDE16	TDPE15	TPDE14	TPDE13	TPDE12	TPDE11	TPDE10	TPDE9
EZDE	25	RW	EZDE16	EZDE15	EZDE14	EZDE13	EZDE12	EZDE11	EZDE10	EZDE9
CVDEB	26	RW	CVDEB16	CVDEB15	CVDEB14	CVDEB13	CVDEB12	CVDEB11	CVDEB10	CVDEB9
Not Used	27-3E	—	—	—	—	—	—	—	—	—
ADDP	3F	RW	ADDP7	ADDP6	ADDP5	ADDP4	ADDP3	ADDP2	ADDP1	ADDP0

Table 6-7. Individual LIU Register Set Bit Map

REGISTER	ADDRESS FOR LIUs 1-8	RW	BIT 7	BIT 6	BIT 5	BIT 4	BIT 3	BIT 2	BIT 1	BIT 0
IJAE	00	RW	IJAE8	IJAE7	IJAE6	IJAE5	IJAE4	IJAE3	IJAE2	IJAE1
IJAPS	01	RW	IJAPS8	IJAPS7	IJAPS6	IJAPS5	IJAPS4	IJAPS3	IJAPS2	IJAPS1
IJAFDS	02	RW	IJAFDS8	IJAFDS7	IJAFDS6	IJAFDS5	IJAFDS4	IJAFDS3	IJAFDS2	IJAFDS1
IJAFLT	03	R	IJAFLT8	IJAFLT7	IJAFLT6	IJAFLT5	IJAFLT4	IJAFLT3	IJAFLT2	IJAFLT1
ISCPD	04	RW	ISCPD8	ISCPD7	ISCPD6	ISCPD5	ISCPD4	ISCPD3	ISCPD2	ISCPD1
IAISEL	05	RW	IAISEL8	IAISEL7	IAISEL6	IAISEL5	IAISEL4	IAISEL3	IAISEL2	IAISEL1
MC	06	RW	PCLKI1	PCLKI0	TECLKE	CLKAE	MPS1	MPS0	FREQS	PLLE
RSMM1	08	RW	RTR2	C2RSM2	C2RSM1	C2RSM0	RTR1	C1RSM2	C1RSM1	C1RSM0
RSMM2	09	RW	RTR4	C4RSM2	C4RSM1	C4RSM0	RTR3	C3RSM2	C3RSM1	C3RSM0
RSMM3	0A	RW	RTR6	C6RSM2	C6RSM1	C6RSM0	RTR5	C5RSM2	C5RSM1	C5RSM0
RSMM4	0B	RW	RTR8	C8RSM2	C8RSM1	C8RSM0	RTR7	C7RSM2	C7RSM1	C7RSM0
RSL1	0C	R	<u>C2RSL3</u>	<u>C2RSL2</u>	<u>C2RSL1</u>	<u>C2RSL0</u>	<u>C1RSL3</u>	<u>C1RSL2</u>	<u>C1RSL1</u>	<u>C1RSL0</u>
RSL2	0D	R	<u>C4RSL3</u>	<u>C4RSL2</u>	<u>C4RSL1</u>	<u>C4RSL0</u>	<u>C3RSL3</u>	<u>C3RSL2</u>	<u>C3RSL1</u>	<u>C3RSL0</u>
RSL3	0E	R	<u>C6RSL3</u>	<u>C6RSL2</u>	<u>C6RSL1</u>	<u>C6RSL0</u>	<u>C5RSL3</u>	<u>C5RSL2</u>	<u>C5RSL1</u>	<u>C5RSL0</u>
RSL4	0F	R	<u>C8RSL3</u>	<u>C8RSL2</u>	<u>C8RSL1</u>	<u>C8RSL0/</u> <u>CALSTAT</u>	<u>C7RSL3</u>	<u>C7RSL2</u>	<u>C7RSL1</u>	<u>C7RSL0</u>
BTCR	10	RW	BTS2	BTS1	BTS0	—	—	—	—	BERTE
BEIR	11	RW	BEIR8	BEIR7	BEIR6	BEIR5	BEIR4	BEIR3	BEIR2	BEIR1
LVDS	12	R	LVDS8	LVDS7	LVDS6	LVDS5	LVDS4	LVDS3	LVDS2	LVDS1
RCLKI	13	RW	RCLKI8	RCLKI7	RCLKI6	RCLKI5	RCLKI4	RCLKI3	RCLKI2	RCLKI1
TCLKI	14	RW	TCLKI8	TCLKI7	TCLKI6	TCLKI5	TCLKI4	TCLKI3	TCLKI2	TCLKI1
CCR	15	RW	PCLKS2	PCLKS1	PCLKS0	TECLKS	CLKA3	CLKA2	CLKA1	CLKA0
RDULR	16	RW	RDULR8	RDULR7	RDULR6	RDULR5	RDULR4	RDULR3	RDULR2	RDULR1
GISC	1E	RW	—	—	—	—	—	—	INTM	CWE
ADDP	1F	RW	ADDP7	ADDP6	ADDP5	ADDP4	ADDP3	ADDP2	ADDP1	ADDP0

REGISTER	ADDRESS FOR LIUs 9-16	RW	BIT 7	BIT 6	BIT 5	BIT 4	BIT 3	BIT 2	BIT 1	BIT 0
IJAE	20	RW	IJAE16	IJAE15	IJAE14	IJAE13	IJAE12	IJAE11	IJAE10	IJAE9
IJAPS	21	RW	IJAPS16	IJAPS15	IJAPS14	IJAPS13	IJAPS12	IJAPS11	IJAPS10	IJAPS9
IJAFDS	22	RW	IJAFDS16	IJAFDS15	IJAFDS14	IJAFDS13	IJAFDS12	IJAFDS11	IJAFDS10	IJAFDS9
IJAFLT	23	R	IJAFLT16	IJAFLT15	IJAFLT14	IJAFLT13	IJAFLT12	IJAFLT11	IJAFLT10	IJAFLT9
ISCPD	24	RW	ISCPD16	ISCPD15	ISCPD14	ISCPD13	ISCPD12	ISCPD11	ISCPD10	ISCPD9
IAISEL	25	RW	IAISEL16	IAISEL15	IAISEL14	IAISEL13	IAISEL12	IAISEL11	IAISEL10	IAISEL9
Not Used	26	RW	—	—	—	—	—	—	—	—
RSMM1	28	RW	RTR10	C10RSM2	C10RSM1	C10RSM0	RTR9	C9RSM2	C9RSM1	C9RSM0
RSMM2	29	RW	RTR12	C12RSM2	C12RSM1	C12RSM0	RTR11	C11RSM2	C11RSM1	C11RSM0
RSMM3	2A	RW	RTR14	C14RSM2	C14RSM1	C14RSM0	RTR13	C13RSM2	C13RSM1	C13RSM0
RSMM4	2B	RW	RTR16	C16RSM2	C16RSM1	C16RSM0	RTR15	C15RSM2	C15RSM1	C15RSM0
RSL1	2C	R	<u>C10RSL3</u>	<u>C10RSL2</u>	<u>C10RSL1</u>	<u>C10RSL0</u>	<u>C9RSL3</u>	<u>C9RSL2</u>	<u>C9RSL1</u>	<u>C9RSL0</u>
RSL2	2D	R	<u>C12RSL3</u>	<u>C12RSL2</u>	<u>C12RSL1</u>	<u>C12RSL0</u>	<u>C11RSL3</u>	<u>C11RSL2</u>	<u>C11RSL1</u>	<u>C11RSL0</u>
RSL3	2E	R	<u>C14RSL3</u>	<u>C14RSL2</u>	<u>C14RSL1</u>	<u>C14RSL0</u>	<u>C13RSL3</u>	<u>C13RSL2</u>	<u>C13RSL1</u>	<u>C13RSL0</u>
RSL4	2F	R	<u>C16RSL3</u>	<u>C16RSL2</u>	<u>C16RSL1</u>	<u>C16RSL0</u>	<u>C15RSL3</u>	<u>C15RSL2</u>	<u>C15RSL1</u>	<u>C15RSL0</u>
BTCR	30	RW	BTS2	BTS1	BTS0	—	—	—	—	BERTE
BEIR	31	RW	BEIR16	BEIR15	BEIR14	BEIR13	BEIR12	BEIR11	BEIR10	BEIR9
LVDS	32	R	LVDS16	LVDS15	LVDS14	LVDS13	LVDS12	LVDS11	LVDS10	LVDS9
RCLKI	33	RW	RCLKI16	RCLKI15	RCLKI14	RCLKI13	RCLKI12	RCLKI11	RCLKI10	RCLKI9
TCLKI	34	RW	TCLKI16	TCLKI15	TCLKI14	TCLKI13	TCLKI12	TCLKI11	TCLKI10	TCLKI9
Not Used	35	RW	—	—	—	—	—	—	—	—
RDULR	36	RW	RDULR16	RDULR15	RDULR14	RDULR13	RDULR12	RDULR11	RDULR10	RDULR9
Not Used	3E	RW	—	—	—	—	—	—	INTM	CWE
ADDP	3F	RW	ADDP7	ADDP6	ADDP5	ADDP4	ADDP3	ADDP2	ADDP1	ADDP0

Note: Underlined bits are read only.

Table 6-8. BERT Register Bit Map

REGISTER	ADDRESS FOR LIUs		RW	BIT 7	BIT 6	BIT 5	BIT 4	BIT 3	BIT 2	BIT 1	BIT 0
	1-8	9-16									
BCR	00	20	RW	PMUM	LPMU	RNPL	RPIC	MPR	APRD	TNPL	TPIC
Not Used	01	<u>21</u>	—	—	—	—	—	—	—	—	—
BPCR1	02	22	RW	—	QRSS	PTS	PLF4	PLF3	PLF2	PLF1	PLF0
BPCR2	03	<u>23</u>	—	—	—	—	PTF4	PTF3	PTF2	PTF1	PTF0
BSPR1	04	24	RW	BSP7	BSP6	BSP5	BSP4	BSP3	BSP2	BSP1	BSP0
BSPR2	05	<u>25</u>	—	BSP15	BSP14	BSP13	BSP12	BSP11	BSP10	BSP9	BSP8
BSPR3	06	26	RW	BSP23	BSP22	BSP21	BSP20	BSP19	BSP18	BSP17	BSP16
BSPR4	07	<u>27</u>	—	BSP31	BSP30	BSP29	BSP28	BSP27	BSP26	BSP25	BSP24
TEICR	08	28	RW	—	—	TEIR2	TEIR1	TEIR0	BEI	TSEI	MEIMS
Not Used	09-0B	<u>29-2B</u>	—	—	—	—	—	—	—	—	—
BSR	0C	2C	R	—	—	—	—	<u>PMS</u>	—	<u>BEC</u>	<u>OOS</u>
Not Used	0D	<u>2D</u>	—	—	—	—	—	—	—	—	—
BSRL	0E	2E	R	—	—	—	—	<u>PMSL</u>	<u>BEL</u>	<u>BECL</u>	<u>OOSL</u>
Not Used	0F	<u>2F</u>	—	—	—	—	—	—	—	—	—
BSRIE	10	30	RW	—	—	—	—	PMSIE	BEIE	BECIE	OOSIE
Not Used	11-13	<u>31-33</u>	—	—	—	—	—	—	—	—	—
RBECR1	14	34	R	<u>BEC7</u>	<u>BEC6</u>	<u>BEC5</u>	<u>BEC4</u>	<u>BEC3</u>	<u>BEC2</u>	<u>BEC1</u>	<u>BEC0</u>
RBECR2	15	35	R	<u>BEC15</u>	<u>BEC14</u>	<u>BEC13</u>	<u>BEC12</u>	<u>BEC11</u>	<u>BEC10</u>	<u>BEC9</u>	<u>BEC8</u>
RBECR3	16	36	R	<u>BEC23</u>	<u>BEC22</u>	<u>BEC21</u>	<u>BEC20</u>	<u>BEC19</u>	<u>BEC18</u>	<u>BEC17</u>	<u>BEC16</u>
Not Used	17	<u>37</u>	—	—	—	—	—	—	—	—	—
RBCR1	18	38	R	<u>BC7</u>	<u>BC6</u>	<u>BC5</u>	<u>BC4</u>	<u>BC3</u>	<u>BC2</u>	<u>BC1</u>	<u>BC0</u>
RBCR2	19	39	R	<u>BC15</u>	<u>BC14</u>	<u>BC13</u>	<u>BC12</u>	<u>BC11</u>	<u>BC10</u>	<u>BC9</u>	<u>BC8</u>
RBCR3	1A	3A	R	<u>BC23</u>	<u>BC22</u>	<u>BC21</u>	<u>BC20</u>	<u>BC19</u>	<u>BC18</u>	<u>BC17</u>	<u>BC16</u>
RBCR4	1B	3B	R	<u>BC31</u>	<u>BC30</u>	<u>BC29</u>	<u>BC28</u>	<u>BC27</u>	<u>BC26</u>	<u>BC25</u>	<u>BC24</u>
Not Used	1C-1E	3C-3E	—	—	—	—	—	—	—	—	—
ADDP	1F	3F	RW	ADDP7	ADDP6	ADDP5	ADDP4	ADDP3	ADDP2	ADDP1	ADDP0

Note: Underlined bits are read only.

6.1 Register Description

This section contains the detailed register descriptions of each bit. Whenever the variable “*n*” in italics is used in any of the register descriptions, it represents 1–16. Note that in the register descriptions, there are duplicate registers for LIUs 1–8 and LIUs 9–16. There are registers in LIUs 1–8 that do not have a duplicate in the register set for LIUs 9–16. For these registers, only one address is listed. All other registers list two addresses, one for LIUs 1–8 and one for LIUs 9–16.

6.1.1 Primary Register Bank

The ADDP register must be set to 00h to access this bank.

Register Name: **ID**
 Register Description: **ID Register**
 Register Address: **00h**

Bit #	7	6	5	4	3	2	1	0
Name	<u>ID7</u>	<u>ID6</u>	<u>ID5</u>	<u>ID4</u>	<u>ID3</u>	<u>ID2</u>	<u>ID1</u>	<u>ID0</u>

Bit 7: Device CODE ID Bit 7 (ID7). This bit is “zero” for short-haul operation.

Bits 6 to 3: Device CODE ID Bits 6 to 3 (ID6 to ID3). These bits tell the user the number of ports the device contains.

Bits 2 to 0: Device CODE ID Bits 2 to 0 (ID2 to ID0). These bits tell the user the revision of the part. Contact the factory for details.

Register Name: **ALBC**
 Register Description: **Analog Loopback Control**
 Register Address (LIUs 1–8): **01h**

Bit #	7	6	5	4	3	2	1	0
Name	ALBC8	ALBC7	ALBC6	ALBC5	ALBC4	ALBC3	ALBC2	ALBC1
Default	0	0	0	0	0	0	0	0

Register Address (LIUs 9–16): **21h**

Bit #	7	6	5	4	3	2	1	0
Name	ALBC16	ALBC15	ALBC14	ALBC13	ALBC12	ALBC11	ALBC10	ALBC9
Default	0	0	0	0	0	0	0	0

Bits 7 to 0: Analog Loopback Control Bits Channel *n* (ALBC_{*n*}). When this bit is set, LIU_{*n*} is placed in Analog Loopback. TTIP and TRING are looped back to RTIP and RRING. The data at RTIP and RRING is ignored. LOS Detector is still in operation. The jitter attenuator is in use if enabled for the transmitter or receiver.

Register Name: **RLBC**
 Register Description: **Remote Loopback Control**
 Register Address (LIUs 1–8): **02h**

Bit #	7	6	5	4	3	2	1	0
Name	RLBC8	RLBC7	RLBC6	RLBC5	RLBC4	RLBC3	RLBC2	RLBC1
Default	0	0	0	0	0	0	0	0

Register Address (LIUs 9–16): **22h**

Bit #	7	6	5	4	3	2	1	0
Name	RLBC16	RLBC15	RLBC14	RLBC13	RLBC12	RLBC11	RLBC10	RLBC9
Default	0	0	0	0	0	0	0	0

Bits 7 to 0: Remote Loopback Control Bits Channel n (RLBC n). When this bit is set, remote loopback is enabled on LIU n . The analog received signal goes through the receive digital and is looped back to the transmitter. The data at TPOS and TNEG is ignored. The jitter attenuator is in use if enabled.

Register Name: **TAOE**
 Register Description: **Transmit All Ones Enable**
 Register Address (LIUs 1–8): **03h**

Bit #	7	6	5	4	3	2	1	0
Name	TAOE8	TAOE7	TAOE6	TAOE5	TAOE4	TAOE3	TAOE2	TAOE1
Default	0	0	0	0	0	0	0	0

Register Address (LIUs 9–16): **23h**

Bit #	7	6	5	4	3	2	1	0
Name	TAOE16	TAOE15	TAOE14	TAOE13	TAOE12	TAOE11	TAOE10	TAOE9
Default	0	0	0	0	0	0	0	0

Bits 7 to 0: Transmit All Ones Enable Channel n (TAOE n). When this bit is set, continuous stream of All ones on TTIP and TRING are sent on Channel n . MCLK is used as a reference clock for Transmit All Ones Signal. The data arriving at TPOS and TNEG is ignored.

Register Name: **LOSS**
 Register Description: **Loss of Signal Status**
 Register Address (LIUs 1–8): **04h**

Bit #	7	6	5	4	3	2	1	0
Name	LOSS8	LOSS7	LOSS6	LOSS5	LOSS4	LOSS3	LOSS2	LOSS1
Default	0	0	0	0	0	0	0	0

Register Address (LIUs 9–16): **24h**

Bit #	7	6	5	4	3	2	1	0
Name	LOSS16	LOSS15	LOSS14	LOSS13	LOSS12	LOSS11	LOSS10	LOSS9
Default	0	0	0	0	0	0	0	0

Bits 7 to 0: Loss of Signal Status Channel n (LOSS n). When this bit is set, a LOS condition has been detected on LIU n . The criteria and conditions of LOS are described in Section [5.5.6](#).

Register Name: **DFMS**
 Register Description: **Driver Fault Monitor Status**
 Register Address (LIUs 1–8): **05h**

Bit #	7	6	5	4	3	2	1	0
Name	<u>DFMS8</u>	<u>DFMS7</u>	<u>DFMS6</u>	<u>DFMS5</u>	<u>DFMS4</u>	<u>DFMS3</u>	<u>DFMS2</u>	<u>DFMS1</u>
Default	0	0	0	0	0	0	0	0

Register Address (LIUs 9–16): **25h**

Bit #	7	6	5	4	3	2	1	0
Name	<u>DFMS16</u>	<u>DFMS15</u>	<u>DFMS14</u>	<u>DFMS13</u>	<u>DFMS12</u>	<u>DFMS11</u>	<u>DFMS10</u>	<u>DFMS9</u>
Default	0	0	0	0	0	0	0	0

Bits 7 to 0: Driver Fault Monitor Status Channel n (DFMS n). When this bit is set, it indicates that there is a short or open circuit at the transmit driver for LIU n .

Register Name: **LOSIE**
 Register Description: **Loss of Signal Interrupt Enable**
 Register Address (LIUs 1–8): **06h**

Bit #	7	6	5	4	3	2	1	0
Name	<u>LOSIE8</u>	<u>LOSIE7</u>	<u>LOSIE6</u>	<u>LOSIE5</u>	<u>LOSIE4</u>	<u>LOSIE3</u>	<u>LOSIE2</u>	<u>LOSIE1</u>
Default	0	0	0	0	0	0	0	0

Register Address (LIUs 9–16): **26h**

Bit #	7	6	5	4	3	2	1	0
Name	<u>LOSIE16</u>	<u>LOSIE15</u>	<u>LOSIE14</u>	<u>LOSIE13</u>	<u>LOSIE12</u>	<u>LOSIE11</u>	<u>LOSIE10</u>	<u>LOSIE9</u>
Default	0	0	0	0	0	0	0	0

Bits 7 to 0: Loss of Signal Interrupt Enable Channel n (LOSIE n). When this bit is set, a change in LOS status for LIU n can generate an Interrupt.

Register Name: **DFMIE**
 Register Description: **Driver Fault Monitor Interrupt Enable**
 Register Address (LIUs 1–8): **07h**

Bit #	7	6	5	4	3	2	1	0
Name	<u>DFMIE8</u>	<u>DFMIE7</u>	<u>DFMIE6</u>	<u>DFMIE5</u>	<u>DFMIE4</u>	<u>DFMIE3</u>	<u>DFMIE2</u>	<u>DFMIE1</u>
Default	0	0	0	0	0	0	0	0

Register Address (LIUs 9–16): **27h**

Bit #	7	6	5	4	3	2	1	0
Name	<u>DFMIE16</u>	<u>DFMIE15</u>	<u>DFMIE14</u>	<u>DFMIE13</u>	<u>DFMIE12</u>	<u>DFMIE11</u>	<u>DFMIE10</u>	<u>DFMIE9</u>
Default	0	0	0	0	0	0	0	0

Bits 7 to 0: Driver Fault Monitor Interrupt Enable Channel n (DFMIE n). When this bit is set, a change in DFM Status can generate an interrupt in monitor n .

Register Name: **LOSI8**
 Register Description: **Loss of Signal Interrupt Status**
 Register Address (LIUs 1–8): **08h**

Bit #	7	6	5	4	3	2	1	0
Name	<u>LOSI8</u>	<u>LOSI7</u>	<u>LOSI6</u>	<u>LOSI5</u>	<u>LOSI4</u>	<u>LOSI3</u>	<u>LOSI2</u>	<u>LOSI1</u>
Default	0	0	0	0	0	0	0	0

Register Address (LIUs 9–16): **28h**

Bit #	7	6	5	4	3	2	1	0
Name	<u>LOSI16</u>	<u>LOSI15</u>	<u>LOSI14</u>	<u>LOSI13</u>	<u>LOSI12</u>	<u>LOSI11</u>	<u>LOSI10</u>	<u>LOSI9</u>
Default	0	0	0	0	0	0	0	0

Bits 7 to 0: Loss of Signal Interrupt Status Channel n (LOSI n). When this bit is set, it indicates a LOS status has transition from a “0 to 1” or “1 to 0” and was detected for LIU n . The bit for LIU n is enabled by register LOSIE (06h). This bit when latched is cleared on a read operation.

Register Name: **DFMIS8**
 Register Description: **Driver Fault Monitor Interrupt Status**
 Register Address (LIUs 1–8): **09h**

Bit #	7	6	5	4	3	2	1	0
Name	<u>DFMIS8</u>	<u>DFMIS7</u>	<u>DFMIS6</u>	<u>DFMIS5</u>	<u>DFMIS4</u>	<u>DFMIS3</u>	<u>DFMIS2</u>	<u>DFMIS1</u>
Default	0	0	0	0	0	0	0	0

Register Address (LIUs 9–16): **29h**

Bit #	7	6	5	4	3	2	1	0
Name	<u>DFMIS16</u>	<u>DFMIS15</u>	<u>DFMIS14</u>	<u>DFMIS13</u>	<u>DFMIS12</u>	<u>DFMIS11</u>	<u>DFMIS10</u>	<u>DFMIS9</u>
Default	0	0	0	0	0	0	0	0

Bits 7 to 0: Driver Fault Status Register Channel n (DFMIS n). When this bit is set, it indicates a DFM status has transitioned from “0 to 1” or “1 to 0” and was detected for LIU n . The bit for LIU n is enabled by register DFMIE (07h). This bit when latched is cleared on a read operation.

Register Name: **SWR**
 Register Description: **Software Reset**
 Register Address (LIUs 1–8): **0Ah**

Bit #	7	6	5	4	3	2	1	0
Name	SWRL	SWRL	SWRL	SWRL	SWRL	SWRL	SWRL	SWRL
Default	0	0	0	0	0	0	0	0

Bits 7 to 0: Software Reset (SWRL). Whenever any write is performed to this register, at least 1 μ s reset will be generated that resets the lower set of registers (LIUs 1–8). All the registers will be restored to their default values. A read operation will always read back all zeros.

Register Address (LIUs 9–16): **2Ah**

Bit #	7	6	5	4	3	2	1	0
Name	SWRU	SWRU	SWRU	SWRU	SWRU	SWRU	SWRU	SWRU
Default	0	0	0	0	0	0	0	0

Bits 7 to 0: Software Reset (SWRU). Whenever any write is performed to this register, at least 1 μ s reset will be generated that resets the upper set of registers (LIUs 9–16). All the registers will be restored to their default values. A read operation will always read back all zeros.

Register Name: **BGMC**
 Register Description: **BERT and G.772 Monitoring Control**
 Register Address (LIUs 1–8): **0Bh**

Bit #	7	6	5	4	3	2	1	0
Name	BERTDIR	BMCKS	BTCKS	—	GMC3	GMC2	GMC1	GMC0
Default	0	0	0	0	0	0	0	0

Bit 7: BERT Direction Control Bit (BERTDIR). When this bit is set, the BERT for LIUs 1–8 will be enabled on the system side of the part (BERT data will come out on RPOS/RNEG and be expected on TPOS/TNEG) for whichever LIU the BERT is enabled.

Bit 6: BERT MCLK Selection (BMCKS). When the BERT is enabled on the system side (BERTDIR = 1), setting this bit will select MCLK as the BERT clock unless BTCKS is set. If neither BMCKS nor BTCKS is set, the BERT will use the recovered clock.

Bit 5: BERT TCLK Selection (BTCKS). When the BERT is enabled on the system side (BERTDIR = 1), setting this bit selects TCLK as the BERT clock, regardless of the state of the BMCKS bit. If neither BMCKS nor BTCKS is set, the BERT will use the recovered clock.

Bits 3 to 0: G.772 Monitoring Control (GMC[3:0]). These bits are used to select transmitter or receiver for nonintrusive monitoring. Receiver 1 is used to monitor Channels 2 to 8 of one receiver from RTIP2–RTIP8/RRING2–RRING8 or of one transmitter from TTIP2–TTIP8/TRING2–TRING8. See [Table 6-9](#).

Register Address (LIUs 9–16): **2Bh**

Bit #	7	6	5	4	3	2	1	0
Name	BERTDIR	BMCKS	BTCKS	—	GMC3	GMC2	GMC1	GMC0
Default	0	0	0	0	0	0	0	0

Bit 7: BERT Direction Control Bit (BERTDIR). When this bit is set, the BERT for LIUs 9–16 will be enabled on the system side of the part (BERT data will come out on RPOS/RNEG and be expected on TPOS/TNEG) for whichever LIU the BERT is enabled.

Bit 6: BERT MCLK Selection (BMCKS). When the BERT is enabled on the system side (BERTDIR = 1), setting this bit will select MCLK as the BERT clock unless BTCKS is set. If neither BMCKS nor BTCKS is set, the BERT will use the recovered clock. If the clock used as the BERT clock is MCLK or the recovered clock, TCLK must be frequency locked to the BERT clock in order for the BERT to sync.

Bit 5: BERT TCLK Selection (BTCKS). When the BERT is enabled on the system side (BERTDIR = 1), setting this bit selects TCLK as the BERT clock, regardless of the state of the BMCKS bit. If neither BMCKS nor BTCKS is set, the BERT will use the recovered clock.

Bits 3 to 0: G.772 Monitoring Control (GMC). These bits are used to select transmitter or receiver for nonintrusive monitoring. Receiver 9 is used to monitor Channels 10 to 16 of one receiver from RTIP10–RTIP16/RRING10–RRING16 or of one transmitter from TTIP10–TTIP16/TRING10–TRING16. See [Table 6-10](#).

Table 6-9. G.772 Monitoring Control (LIU 1)

GMC3	GMC2	GMC1	GMC0	SELECTION
0	0	0	0	No Monitoring
0	0	0	1	Receiver 2
0	0	1	0	Receiver 3
0	0	1	1	Receiver 4
0	1	0	0	Receiver 5
0	1	0	1	Receiver 6
0	1	1	0	Receiver 7
0	1	1	1	Receiver 8
1	0	0	0	No Monitoring
1	0	0	1	Transmitter 2
1	0	1	0	Transmitter 3
1	0	1	1	Transmitter 4
1	1	0	0	Transmitter 5
1	1	0	1	Transmitter 6
1	1	1	0	Transmitter 7
1	1	1	1	Transmitter 8

Table 6-10. G.772 Monitoring Control (LIU 9)

GMC3	GMC2	GMC1	GMC0	SELECTION
0	0	0	0	No Monitoring
0	0	0	1	Receiver 10
0	0	1	0	Receiver 11
0	0	1	1	Receiver 12
0	1	0	0	Receiver 13
0	1	0	1	Receiver 14
0	1	1	0	Receiver 15
0	1	1	1	Receiver 16
1	0	0	0	No Monitoring
1	0	0	1	Transmitter 10
1	0	1	0	Transmitter 11
1	0	1	1	Transmitter 12
1	1	0	0	Transmitter 13
1	1	0	1	Transmitter 14
1	1	1	0	Transmitter 15
1	1	1	1	Transmitter 16

Register Name: **DLBC**
 Register Description: **Digital Loopback Control**
 Register Address (LIUs 1–8): **0Ch**

Bit #	7	6	5	4	3	2	1	0
Name	DLBC8	DLBC7	DLBC6	DLBC5	DLBC4	DLBC3	DLBC2	DLBC1
Default	0	0	0	0	0	0	0	0

Register Address (LIUs 9–16): **2Ch**

Bit #	7	6	5	4	3	2	1	0
Name	DLBC16	DLBC15	DLBC14	DLBC13	DLBC12	DLBC11	DLBC10	DLBC9
Default	0	0	0	0	0	0	0	0

Bits 7 to 0: Digital Loopback Control Channel n (DLBC n). When this bit is set the LIU n is placed in digital loopback. The data at TPOS/TNEG is encoded and looped back to the decoder and output on RPOS/RNEG. The Jitter Attenuator can optionally be included in the transmit or receive paths.

Register Name: **LASCS**
 Register Description: **LOS/AIS Criteria Selection**
 Register Address (LIUs 1–8): **0Dh**

Bit #	7	6	5	4	3	2	1	0
Name	LASCS8	LASCS7	LASCS6	LASCS5	LASCS4	LASCS3	LASCS2	LASCS1
Default	0	0	0	0	0	0	0	0

Register Address (LIUs 9–16): **2Dh**

Bit #	7	6	5	4	3	2	1	0
Name	LASCS16	LASCS15	LASCS14	LASCS13	LASCS12	LASCS11	LASCS10	LASCS9
Default	0	0	0	0	0	0	0	0

Bits 7 to 0: LOS/AIS Criteria Selection Channel n (LASCS n). This bit is used for LOS/AIS selection criteria for LIU n . In E1 mode, if set it uses ETS 300 233 mode selections. If reset it uses G.775 criteria. In T1/J1 mode T1.231 criteria is selected.

Register Name: **ATAOS**
 Register Description: **Automatic Transmit All Ones Select**
 Register Address (LIUs 1–8): **0Eh**

Bit #	7	6	5	4	3	2	1	0
Name	ATAOS8	ATAOS7	ATAOS6	ATAOS5	ATAOS4	ATAOS3	ATAOS2	ATAOS1
Default	0	0	0	0	0	0	0	0

Register Address (LIUs 9–16): **2Eh**

Bit #	7	6	5	4	3	2	1	0
Name	ATAOS16	ATAOS15	ATAOS14	ATAOS13	ATAOS12	ATAOS11	ATAOS10	ATAOS9
Default	0	0	0	0	0	0	0	0

Bits 7 to 0: Automatic Transmit All Ones Select Channel n (ATAOS n). When this bit is set all ones signal is sent if an LOS is detected for LIU n . “All Ones Signal” uses MCLK as the reference clock.

Register Name: **GC**
 Register Description: **Global Configuration**
 Register Address (LIUs 1–8): **0Fh**

Bit #	7	6	5	4	3	2	1	0
Name	RIMPMS	AISEL	SCPD	CODE	JADS	CRIMP	JAPS	JAE
Default	0	0	0	0	0	0	0	0

Note: CRIMP controls all 16 LIUs. All other bits are for LIUs 1–8 only.

Bit 7: Receive Impedance Mode Select (RIMPMS). When this bit is set, fully internal impedance match mode is selected, so RTIP and RRING require no external resistor. If this bit is set, the receiver line transformer must be a 1:1 turns ratio and the RTR bit set. When reset, external termination mode is selected and an external resistor is required to terminate the receive line. This external resistor will be adjusted internally to the correct termination value if partially internal impedance matching is turned on ([TS.RIMPON](#) = 1).

Bit 6: AIS Enable During Loss (AISEL). When this bit is set, an AIS is sent to the system side upon detecting LOS for each channel. The individual LIU register [IAISEL](#) settings will be ignored when this bit is set. When reset, the [IAISEL](#) register will have control.

Bit 5: Short Circuit Protection Disable (SCPD). If this bit is set the short-circuit protection is disabled for all the transmitters. The individual LIU register [ISCPD](#) settings will be ignored when this bit is set. When reset, the [ISCPD](#) register will have control.

Bit 4: Code (CODE). If this bit is set AMI encoder/decoder is selected. The [LCS](#) register settings will be ignored when this bit is set. If reset, the [LCS](#) register will have control.

Bit 3: Jitter Attenuator Depth Select (JADS). If this bit is set the jitter attenuator FIFO depth is 128 bits. The settings in the [IJAFDS](#) register will be ignored if this register is set. If reset the [IJAFDS](#) register will have control.

Bit 2: Calibrate Receive Internal Termination (CRIMP). A low-to-high transition on this bit initiates a calibration cycle for the receive internal termination. This requires a 16k Ω \pm 1% resistor on the RESREF pin. Bit 2 of the GC register at address 0x2F must also be set to enable calibration. While this bit is set, [RSL4.4](#) (0x0F in individual bank) will indicate the status of the calibration cycle.

Bit 1: Jitter Attenuator Position Select (JAPS). When the JAPS bit is set high, the jitter attenuator will be in the receive path and when default or set low in the Transmit path. These settings can be changed for an individual LIU by settings in the [IJAPS](#) register. Note that when bit JAE is set, the settings in the [IJAPS](#) register will be ignored.

Bit 0: Jitter Attenuator Enable (JAE). When this bit is set the jitter attenuator is enabled. The settings in the [IJAE](#) register will be ignored if this register is set. If reset, the IJAE register will have control.

Register Address (LIUs 9–16): **2Fh**

Bit #	7	6	5	4	3	2	1	0
Name	RIMPMS	AISEL	SCPD	CODE	JADS	CALEN	JAPS	JAE
Default	0	0	0	0	0	0	0	0

Bit 7: Receive Impedance Mode Select (RIMPMS). When this bit is set, the fully internal receive impedance matching mode is selected, so RTIP and RRING require no external resistor. If this bit is set, the receiver line transformer must be a 1:1 turns ratio and the RTR bit set. When reset and [TS.RIMPON](#) = 1, partially internal receive impedance matching mode is selected and an external resistor is required to terminate the receive line. This external resistor will be adjusted internally to the correct termination value.

Bit 6: AIS Enable During Loss (AISEL). When this bit is set, an AIS is sent to the system side upon detecting LOS for each channel. The individual LIU register [IAISEL](#) settings will be ignored when this bit is set. When reset, the [IAISEL](#) register will have control.

Bit 5: Short Circuit Protection Disable (SCPD). If this bit is set the short-circuit protection is disabled for all the transmitters. The individual LIU register [ISCPD](#) settings will be ignored when this bit is set. When reset, the [ISCPD](#) register will have control.

Bit 4: Code (CODE). If this bit is set AMI encoder/decoder is selected. The [LCS](#) register settings will be ignored when this bit is set. If reset, the [LCS](#) register will have control.

Bit 3: Jitter Attenuator Depth Select (JADS). If this bit is set the jitter attenuator FIFO depth is 128 bits. The settings in the [IJAFDS](#) register will be ignored if this register is set. If reset the [IJAFDS](#) register will have control.

Bit 2: Calibrate Receive Impedance Match (CALEN). This bit must be set to enable calibration of the receive termination. If this bit is set and a 16k Ω resistor is on the RESREF pin, then a low-to-high transition on the CRIMP bit will initiate a calibration cycle for the receive internal termination. The user should wait at least 5 μ s before setting the CRIMP bit.

Bit 1: Jitter Attenuator Position Select (JAPS). When the JAPS bit is set, the jitter attenuator will be in the receive path for each channel. The individual LIU register [IJAPS](#) settings will be ignored when this bit is set. When reset, the [IJAPS](#) register will have control.

Bit 0: Jitter Attenuator Enable (JAE). When this bit is set the jitter attenuator is enabled. The settings in the [IJAE](#) register will be ignored if this register is set. If reset, the IJAE register will have control.

Register Name: **TST**
 Register Description: **Template Select Transmitter**
 Register Address (LIUs 1–8): **10h**

Bit #	7	6	5	4	3	2	1	0
Name	JABWS1	JABWS0	RHPMC	—	—	TST2	TST1	TST0
Default	0	0	0	0	0	0	0	0

Bits 7 and 6: Jitter Attenuator Bandwidth Selection [1:0] (JABWS[1:0]). In E1 mode, JABWS[1:0] is used to control the bandwidth of the jitter attenuator according to the following table:

JABWS	BANDWIDTH (Hz)
00	0.625
01	1.25
10	2.5
11	5

Bit 5: Receive Hitless Protection Mode Control (RHPMC). When this bit is set, the receive impedance match on/off selection will be controlled by the OE pin. If OE is high, receive impedance match is on. If OE is low, receive impedance match is off (Internal impedance to RTIP and RRING is high impedance). When this bit is reset, the RIMPON register bit will control receive impedance match.

Bits 2 to 0: TST Template Select Transceiver [2:0] (TST[2:0]). TST[2:0] is used to select the transceiver that the Transmit Template Select Register (0x11) will configure for LIUs 1–8. See [Table 6-11](#).

Register Address (LIUs 9–16): **30h**

Bit #	7	6	5	4	3	2	1	0
Name	JABWS1	JABWS0	RHPMC	—	—	TST2	TST1	TST0
Default	0	0	0	0	0	0	0	0

Bits 7 and 6: Jitter Attenuator Bandwidth Selection [1:0] (JABWS[1:0]). In E1 mode, JABWS[1:0] is used to control the bandwidth of the jitter attenuator according to the following table:

JABWS	BANDWIDTH (Hz)
00	0.625
01	1.25
10	2.5
11	5

Bit 5: Receive Hitless Protection Mode Control (RHPMC). When this bit is set, the receive impedance match on/off selection will be controlled by the OE pin. If OE is high, receive impedance match is on. If OE is low, receive impedance match is off (internal impedance to RTIP and RRING is high impedance). When this bit is reset, the RIMPON register bit will control receive impedance match.

Bits 2 to 0: TST Template Select Transceiver [2:0] (TST[2:0]). TST[2:0] is used to select the transceiver that the Transmit Template Select Register (0x11) will configure for LIUs 9–16. See [Table 6-12](#).

Table 6-11. TST Template Select Transmitter Register (LIUs 1–8)

TST[2:0]	CHANNEL	TST[2:0]	CHANNEL
000	1	100	5
001	2	101	6
010	3	110	7
011	4	111	8

Table 6-12. TST Template Select Transmitter Register (LIUs 9–16)

TST[2:0]	CHANNEL	TST[2:0]	CHANNEL
000	9	100	13
001	10	101	14
010	11	110	15
011	12	111	16

Register Name: **TS**
 Register Description: **Template Select**
 Register Address (LIUs 1–8): **11h**
 Register Address (LIUs 9–16): **31h**

Bit #	7	6	5	4	3	2	1	0
Name	RIMPON	TIMPOFF	—	—	TIMPRM	TS2	TS1	TS0
Default	0	0	0	0	0	0	0	0

Note: This register configures each LIU individually. This register configures the LIU selected by [TSI.TST\[2:0\]](#).

Bit 7: Receive Impedance Match On (RIMPON). If this bit is set, internal receive impedance matching is turned on. Otherwise, the receiver is in high impedance. Note that the OE pin can have control instead of this bit when the [TST.RHPMC](#) bit is set.

Bit 6: Transmit Impedance Termination Off (TIMPOFF). If this bit is set all the internal transmit terminating impedance is turned off.

Bit 3: Transmit Impedance Receive Match (TIMPRM). This bit selects the internal transmit termination impedance and receive impedance match for E1 mode and T1/J1 mode.

0 = 75Ω for E1 mode or 100Ω for T1 mode.

1 = 120Ω for E1 mode or 110Ω for J1 mode.

Bits 2 to 0: Template Selection [2:0] (TS[2:0]). Bits TS[2:0] are used to select E1 or T1/J1 mode, the template, and the settings for various cable lengths. The impedance termination for the transmitter and impedance match for the receiver are specified by bit TIMPRM. See [Table 6-13](#) for bit selection of TS[2:0].

Table 6-13. Template Selection

TEMPLATE SELECTION			
TS[2:0]	LINE LENGTH (ft)	CABLE LOSS (dB)	IMPEDANCE (Ω)
011	0–133 ABAM	0.6	100/110
100	133–266 ABAM	1.2	100/110
101	266–399 ABAM	1.8	100/110
110	399–533 ABAM	2.4	100/110
111	533–655 ABAM	3.0	100/110
000	G.703 coaxial and twisted pair cable		75/120
001 and 010	Reserved	—	—

Register Name: **OE**
 Register Description: **Output Enable Configuration**
 Register Address (LIUs 1–8): **12h**

Bit #	7	6	5	4	3	2	1	0
Name	OE8	OE7	OE6	OE5	OE4	OE3	OE2	OE1
Default	0	0	0	0	0	0	0	0

Register Address (LIUs 9–16): **32h**

Bit #	7	6	5	4	3	2	1	0
Name	OE16	OE15	OE14	OE13	OE12	OE11	OE10	OE9
Default	0	0	0	0	0	0	0	0

Bits 7 to 0: Output Enable Channel n (OEn). When this bit is reset, the transmitter output for LIUn is high impedance. When this bit is set, the transmitter output for LIUn is enabled. Note that the OE pin will override this setting when low.

Register Name: **AIS**
 Register Description: **Alarm Indication Signal Status**
 Register Address (LIUs 1–8): **13h**

Bit #	7	6	5	4	3	2	1	0
Name	<u>AIS8</u>	<u>AIS7</u>	<u>AIS6</u>	<u>AIS5</u>	<u>AIS4</u>	<u>AIS3</u>	<u>AIS2</u>	<u>AIS1</u>
Default	0	0	0	0	0	0	0	0

Register Address (LIUs 9–16): **33h**

Bit #	7	6	5	4	3	2	1	0
Name	<u>AIS16</u>	<u>AIS15</u>	<u>AIS14</u>	<u>AIS13</u>	<u>AIS12</u>	<u>AIS11</u>	<u>AIS10</u>	<u>AIS9</u>
Default	0	0	0	0	0	0	0	0

Bits 7 to 0: Alarm Indication Signal Channel n (AISn). This bit will be set when AIS is detected for LIUn. The criteria for AIS selection is detailed in Section [5.5.7](#). The selection of the AIS criteria is done by settings in the [LASCS](#) (0D) register.

Register Name: **AISIE**
 Register Description: **AIS Interrupt Enable**
 Register Address (LIUs 1–8): **14h**

Bit #	7	6	5	4	3	2	1	0
Name	AISIE8	AISIE7	AISIE6	AISIE5	AISIE4	AISIE3	AISIE2	AISIE1
Default	0	0	0	0	0	0	0	0

Register Address (LIUs 9–16): **34h**

Bit #	7	6	5	4	3	2	1	0
Name	AISIE16	AISIE15	AISIE14	AISIE13	AISIE12	AISIE11	AISIE10	AISIE9
Default	0	0	0	0	0	0	0	0

Bits 7 to 0: AIS Interrupt Mask Channel n (AISIE n). When this bit is set, interrupts can be generated for LIU n if AIS status transitions.

Register Name: **AISIS**
 Register Description: **AIS Interrupt Status**
 Register Address (LIUs 1–8): **15h**

Bit #	7	6	5	4	3	2	1	0
Name	AISIS8	AISIS7	AISIS6	AISIS5	AISIS4	AISIS3	AISIS2	AISIS1
Default	0	0	0	0	0	0	0	0

Register Address (LIUs 9–16): **35h**

Bit #	7	6	5	4	3	2	1	0
Name	AISIS16	AISIS15	AISIS14	AISIS13	AISIS12	AISIS11	AISIS10	AISIS9
Default	0	0	0	0	0	0	0	0

Bits 7 to 0: AIS Interrupt Status Channel n (AISIS n). This bit is set when AIS ransitions from a “0 to 1” or “1 to 0” and interrupts are enabled by the [AISIE](#)(14) register for LIU n . If set, this bit is cleared on a read operation or when the interrupt enable register is disabled.

Register Name: **ADDP**
 Register Description: **Address Pointer for Bank Selection**
 Register Address (LIUs 1–8): **1Fh**
 Register Address (LIUs 9–16): **3Fh**

Bit #	7	6	5	4	3	2	1	0
Name	ADDP7	ADDP6	ADDP5	ADDP4	ADDP3	ADDP2	ADDP1	ADDP0
Default	0	0	0	0	0	0	0	0

Bits 7 to 0: Address Pointer (ADDP). This pointer is used to switch between pointing to the primary registers, the secondary registers, individual registers, and BERT registers. See [Table 6-14](#) for bank selection. The register space contains control for Channels 1 to 8 from address 00 hex to 1F hex and a duplicate set of registers for control of Channels 9 to 16 from address 20 hex to 3F hex. The ADDP at address 1F hex select the banks for the set of registers for LIUs 1–8. The ADDP register at address 3F select the banks for the set of registers for LIUs 9–16.

Table 6-14. Address Pointer Bank Selection

ADDP[7:0] (HEX)	BANK NAME
00	Primary Bank
AA	Secondary Bank
01	Individual LIU Bank
02	BERT Bank

6.1.2 Secondary Register Bank

The ADDP register must be set to AAh in order to access this bank.

Register Name: **SRMS**
 Register Description: **Single-Rail Mode Select**
 Register Address (LIUs 1–8): **00h**

Bit #	7	6	5	4	3	2	1	0
Name	SRMS8	SRMS7	SRMS6	SRMS5	SRMS4	SRMS3	SRMS2	SRMS1
Default	0	0	0	0	0	0	0	0

Register Address (LIUs 9–16): **20h**

Bit #	7	6	5	4	3	2	1	0
Name	SRMS16	SRMS15	SRMS14	SRMS13	SRMS12	SRMS11	SRMS10	SRMS9
Default	0	0	0	0	0	0	0	0

Bits 7 to 0: Single-Rail Mode Select Channel n (SRMS n). When this bit is set single-rail mode is selected for the system transmit and receive n . If this bit is reset, dual-rail is selected.

Register Name: **LCS**
 Register Description: **Line Code Selection**
 Register Address (LIUs 1–8): **01h**

Bit #	7	6	5	4	3	2	1	0
Name	LCS8	LCS7	LCS6	LCS5	LCS4	LCS3	LCS2	LCS1
Default	0	0	0	0	0	0	0	0

Register Address (LIUs 9–16): **21h**

Bit #	7	6	5	4	3	2	1	0
Name	LCS16	LCS15	LCS14	LCS13	LCS12	LCS11	LCS10	LCS9
Default	0	0	0	0	0	0	0	0

Bits 7 to 0: Line Code Select Channel n (LCS n). When this bit is set AMI encoding/decoding is selected for LIU n . If reset, B8ZS or HDB3 encoding/decoding is selected for LIU n . Note that if the [GC.CODE](#) register bit is set it will ignore this register.

Register Name: **RPDE**
 Register Description: **Receive Power-Down Enable**
 Register Address (LIUs 1–8): **03h**

Bit #	7	6	5	4	3	2	1	0
Name	RPDE8	RPDE7	RPDE6	RPDE5	RPDE4	RPDE3	RPDE2	RPDE1
Default	0	0	0	0	0	0	0	0

Register Address (LIUs 9–16): **23h**

Bit #	7	6	5	4	3	2	1	0
Name	RPDE16	RPDE15	RPDE14	RPDE13	RPDE12	RPDE11	RPDE10	RPDE9
Default	0	0	0	0	0	0	0	0

Bits 7 to 0: Receive Power-Down Enable Channel n (RPDE n). When this bit is set the receiver for LIU n is powered down.

Register Name: **TPDE**
 Register Description: **Transmit Power-Down Enable**
 Register Address (LIUs 1–8): **04h**

Bit #	7	6	5	4	3	2	1	0
Name	TPDE8	TPDE7	TPDE6	TPDE5	TPDE4	TPDE3	TPDE2	TPDE1
Default	0	0	0	0	0	0	0	0

Register Address (LIUs 9–16): **24h**

Bit #	7	6	5	4	3	2	1	0
Name	TPDE16	TPDE15	TPDE14	TPDE13	TPDE12	TPDE11	TPDE10	TPDE9
Default	0	0	0	0	0	0	0	0

Bits 7 to 0: Transmit Power-Down Enable Channel n (TPDE n). When this bit is set the transmitter for LIU n is powered down.

Register Name: **EZDE**
 Register Description: **Excessive Zero Detect Enable**
 Register Address (LIUs 1–8): **05h**

Bit #	7	6	5	4	3	2	1	0
Name	EZDE8	EZDE7	EZDE6	EZDE5	EZDE4	EZDE3	EZDE2	EZDE1
Default	0	0	0	0	0	0	0	0

Register Address (LIUs 9–16): **25h**

Bit #	7	6	5	4	3	2	1	0
Name	EZDE16	EZDE15	EZDE14	EZDE13	EZDE12	EZDE11	EZDE10	EZDE9
Default	0	0	0	0	0	0	0	0

Bits 7 to 0: Excessive Zero Detect Enable Channel n (EZDE n). When this bit is reset excessive zero detection is disabled for LIU n . When this bit is set excessive zero detect enable is enabled. Excessive zero detection is only relevant when HDB3 or B8ZS decoding is enabled ([LCS](#) register).

Register Name: **CVDEB**
 Register Description: **Code Violation Detect Enable Bar**
 Register Address (LIUs 1–8): **06h**

Bit #	7	6	5	4	3	2	1	0
Name	CVDEB8	CVDEB7	CVDEB6	CVDEB5	CVDEB4	CVDEB3	CVDEB2	CVDEB1
Default	0	0	0	0	0	0	0	0

Register Address (LIUs 9–16): **26h**

Bit #	7	6	5	4	3	2	1	0
Name	CVDEB16	CVDEB15	CVDEB14	CVDEB13	CVDEB12	CVDEB11	CVDEB10	CVDEB9
Default	0	0	0	0	0	0	0	0

Bits 7 to 0: Code Violation Detect Enable Bar Channel n (CVDEB n). If this bit is set, code violation detection is disabled for the LIU n . If this bit is reset, code violation detection is enabled. Code violation detection is only relevant when HDB3 decoding is enabled ([LCS](#) register).

6.1.3 Individual LIU Register Bank

The ADDP register must be set to 01h to access this bank.

Register Name: **IJAE**
 Register Description: **Individual Jitter Attenuator Enable**
 Register Address (LIUs 1–8): **00h**

Bit #	7	6	5	4	3	2	1	0
Name	IJAE8	IJAE7	IJAE6	IJAE5	IJAE4	IJAE3	IJAE2	IJAE1
Default	0	0	0	0	0	0	0	0

Register Address (LIUs 9–16): **20h**

Bit #	7	6	5	4	3	2	1	0
Name	IJAE16	IJAE15	IJAE14	IJAE13	IJAE12	IJAE11	IJAE10	IJAE9
Default	0	0	0	0	0	0	0	0

Bits 7 to 0: Individual Jitter Attenuator Enable Channel n (IJAE n). When this bit is set, the LIU jitter attenuator n is enabled. Note that if the [GC.JAE](#) register bit is set, this register will be ignored.

Register Name: **IJAPS**
 Register Description: **Individual Jitter Attenuator Position Select**
 Register Address (LIUs 1–8): **01h**

Bit #	7	6	5	4	3	2	1	0
Name	IJAPS8	IJAPS7	IJAPS6	IJAPS5	IJAPS4	IJAPS3	IJAPS2	IJAPS1
Default	0	0	0	0	0	0	0	0

Register Address (LIUs 9–16): **21h**

Bit #	7	6	5	4	3	2	1	0
Name	IJAPS16	IJAPS15	IJAPS14	IJAPS13	IJAPS12	IJAPS11	IJAPS10	IJAPS9
Default	0	0	0	0	0	0	0	0

Bits 7 to 0: Individual Jitter Attenuator Position Select Channel n (IJAPS n). When this bit is set high, the jitter attenuator is in the receive path n ; when this bit is default or set low the jitter attenuator is in the transmit path n . Note that if the [GC.JAE](#) register bit is set, this register will be ignored.

Register Name: **IJAFDS**
 Register Description: **Individual Jitter Attenuator FIFO Depth Select**
 Register Address (LIUs 1–8): **02h**

Bit #	7	6	5	4	3	2	1	0
Name	IJAFDS8	IJAFDS7	IJAFDS6	IJAFDS5	IJAFDS4	IJAFDS3	IJAFDS2	IJAFDS1
Default	0	0	0	0	0	0	0	0

Register Address (LIUs 9–16): **22h**

Bit #	7	6	5	4	3	2	1	0
Name	IJAFDS16	IJAFDS15	IJAFDS14	IJAFDS13	IJAFDS12	IJAFDS11	IJAFDS10	IJAFDS9
Default	0	0	0	0	0	0	0	0

Bits 7 to 0: Individual Jitter Attenuator FIFO Depth Select n (IJAFDS n). When this bit is set for LIU n the jitter attenuator FIFO depth will be 128 bits. When reset the jitter attenuator FIFO depth will be 32 bits. Note that if the [GC.IJAFDS](#) register bit is set, this register will be ignored.

Register Name: **IJAFLT**
 Register Description: **Individual Jitter Attenuator FIFO Limit Trip**
 Register Address (LIUs 1–8): **03h**

Bit #	7	6	5	4	3	2	1	0
Name	IJAFLT8	IJAFLT7	IJAFLT6	IJAFLT5	IJAFLT4	IJAFLT3	IJAFLT2	IJAFLT1
Default	0	0	0	0	0	0	0	0

Register Address (LIUs 9–16): **23h**

Bit #	7	6	5	4	3	2	1	0
Name	IJAFLT16	IJAFLT15	IJAFLT14	IJAFLT13	IJAFLT12	IJAFLT11	IJAFLT10	IJAFLT9
Default	0	0	0	0	0	0	0	0

Bits 7 to 0: Individual Jitter Attenuator FIFO Limit Trip n (IJAFLT n). Set when the jitter attenuator FIFO reaches to within 4 bits of its useful limit for transmitter n . This bit will be cleared when read.

Register Name: **ISCPD**
 Register Description: **Individual Short-Circuit Protection Disable**
 Register Address (LIUs 1–8): **04h**

Bit #	7	6	5	4	3	2	1	0
Name	ISCPD8	ISCPD7	ISCPD6	ISCPD5	ISCPD4	ISCPD3	ISCPD2	ISCPD1
Default	0	0	0	0	0	0	0	0

Register Address (LIUs 9–16): **24h**

Bit #	7	6	5	4	3	2	1	0
Name	ISCPD16	ISCPD15	ISCPD14	ISCPD13	ISCPD12	ISCPD11	ISCPD10	ISCPD9
Default	0	0	0	0	0	0	0	0

Bits 7 to 0: Individual Short-Circuit Protection Disable n (ISCPD n). When this bit is set the short-circuit protection is disabled for the individual transmitter n . Note that if the [GC.SCPD](#) register bit is set, the settings in this register will be ignored.

Register Name: **IAISEL**
 Register Description: **Individual AIS Select**
 Register Address (LIUs 1–8): **05h**

Bit #	7	6	5	4	3	2	1	0
Name	IAISEL8	IAISEL7	IAISEL6	IAISEL5	IAISEL4	IAISEL3	IAISEL2	IAISEL1
Default	0	0	0	0	0	0	0	0

Register Address (LIUs 9–16): **25h**

Bit #	7	6	5	4	3	2	1	0
Name	IAISEL16	IAISEL15	IAISEL14	IAISEL13	IAISEL12	IAISEL11	IAISEL10	IAISEL9
Default	0	0	0	0	0	0	0	0

Bits 7 to 0: Individual AIS Enable During Loss n (IAISEL n). When this bit is set, individual AIS enable during loss is enabled for the individual receiver n , and AIS is sent to the system side upon detection of an LOS. Note that if the [GC.AISEL](#) register bit is set, the settings in this register will be ignored.

Register Name: **MC**
 Register Description: **Master Clock Select**
 Register Address: **06h**

Bit #	7	6	5	4	3	2	1	0
Name	PCLKI1	PCLKI0	TECLKE	CLKAE	MPS1	MPS0	FREQS	PLLE
Default	0	0	0	0	0	0	0	0

Bits 7 and 6: PLL Clock Input [1:0] (PCLKI[1:0]). These bits select the input into to the PLL.

00: MCLK is used.

01: RCLK1 to 8 is used based on the selection in register [CCR](#).

10: RCLK9 to 16 is used based on the selection in register CCR.

11: Reserved.

Bit 5: T1/E1 Clock Enable (TECLKE). When this bit is set the TECLK output is enabled. If not set TECLK will be disabled and the TECLK output is a LOS output. TECLK requires PLLE to be set for correct functionality.

Bit 4: Clock A Enable (CLKAE). When this bit is set the CLKA output is enabled. If not set CLKA will be disabled and the CLKA output is a LOS output. CLKA requires PLLE to be set for correct functionality.

Bits 3 and 2: Master Period Select [1:0] (MPS[1:0]). These bits MPS[1:0] selects the external MCLK frequency for the DS26324. See [Table 6-15](#) for details. This register when written to will also controller functionality of Channels 9 to 16.

Bit 1: Frequency Select (FREQS). In conjunction with MPS[1:0] selects the external MCLK frequency for the DS26324. If this bit is set the external Master clock can be 1.544MHz or multiple thereof. If not set the external master clock can be 2.048MHz or multiple thereof. See [Table 6-15](#) for details. This register when written to will also controller functionality of Channels 9 to 16.

Bit 0: Phase Lock Loop Enable (PLLE). When this bit is set the phase lock loop is enabled. If not set MCLK will be the applied input clock.

Table 6-15. DS26324 MCLK Selections

PLLE	MPS1, MPS0	MCLK, MHz \pm 50ppm	FREQS	MODE
0	xx	1.544	x	T1
0	xx	2.048	x	E1
1	00	1.544	1	T1/J1 or E1
1	01	3.088	1	T1/J1 or E1
1	10	6.176	1	T1/J1 or E1
1	11	12.352	1	T1/J1 or E1
1	00	2.048	0	T1/J1 or E1
1	01	4.096	0	T1/J1 or E1
1	10	8.192	0	T1/J1 or E1
1	11	16.384	0	T1/J1 or E1

Register Name: **RSMM1**
 Register Description: **Receive Sensitivity Monitor Mode 1**
 Register Address (LIUs 1–8): **08h**

Bit #	7	6	5	4	3	2	1	0
Name	RTR2	C2RSM2	C2RSM1	C2RSM0	RTR1	C1RSM2	C1RSM1	C1RSM0
Default	0	0	0	0	0	0	0	0

Bit 7: Receiver Transformer Turns Ratio Channel 2 (RTR2). If this bit is set the turns ratio is 1:1 on the receiver side. This bit should be set when a 1:1 receiver transformer is used. Note that in order to use fully internal receive impedance termination, a 1:1 transformer must be used and this bit must be set to 1.

Bits 6 to 4: Channel 2 Receive Sensitivity/Monitor Select [2:0] (C2RSM[2:0]). Bits C2RSM[2:0] are used to select the receiver sensitivity level and the monitor mode resistive gain. See [Table 6-16](#).

Bit 3: Receiver Transformer Turns Ratio Channel 1 (RTR1). If this bit is set the turns ratio is 1:1 on the receiver side. This bit should be set when a 1:1 receiver transformer is used. Note that in order to use the fully internal receive impedance termination, a 1:1 transformer must be used and this bit must be set to 1.

Bits 2 to 0: Channel 1 Receive Sensitivity/Monitor Select [2:0] (C1RSM[2:0]). Bits C1RSM[2:0] are used to select the receiver sensitivity level and the monitor mode resistive gain. See [Table 6-16](#).

Register Address (LIUs 9–16): **28h**

Bit #	7	6	5	4	3	2	1	0
Name	RTR10	C10RSM2	C10RSM1	C10RSM0	RTR9	C9RSM2	C9RSM1	C9RSM0
Default	0	0	0	0	0	0	0	0

Bit 7: Receiver Transformer Turns Ratio Channel 10 (RTR10). If this bit is set the turns ratio is 1:1 on the receiver side. This bit should be set when a 1:1 receiver transformer is used. Note that in order to use fully internal receive impedance termination, a 1:1 transformer must be used and this bit must be set to 1.

Bits 6 to 4: Channel 10 Receive Sensitivity/Monitor Select [2:0] (C10RSM[2:0]). Bits C10RSM[2:0] are used to select the receiver sensitivity level and the monitor mode resistive gain. See [Table 6-16](#).

Bit 3: Receiver Transformer Turns Ratio Channel 9 (RTR9). If this bit is set the Turns Ratio is 1:1 on the receiver side. This bit should be set when a 1:1 receiver transformer is used. Note that in order to use the fully internal receive impedance termination, a 1:1 transformer must be used and this bit must be set to 1.

Bits 2 to 0: Channel 9 Receive Sensitivity/Monitor Select [2:0] (C9RSM[2:0]). Bits C9RSM[2:0] are used to select the receiver sensitivity level and the monitor mode resistive gain. See [Table 6-16](#).

Register Name: **RSMM2**
 Register Description: **Receive Sensitivity Monitor Mode 2**
 Register Address (LIUs 1–8): **09h**

Bit #	7	6	5	4	3	2	1	0
Name	RTR4	C4RSM2	C4RSM1	C4RSM0	RTR3	C3RSM2	C3RSM1	C3RSM0
Default	0	0	0	0	0	0	0	0

Bit 7: Receiver Transformer Turns Ratio Channel 4 (RTR4). If this bit is set the turns ratio is 1:1 on the receiver side. This bit should be set when a 1:1 receiver transformer is used. Note that in order to use fully internal receive impedance termination, a 1:1 transformer must be used and this bit must be set to 1.

Bit 6 to 4: Channel 4 Receive Sensitivity/Monitor Select [2:0] (C4RSM[2:0]). Bits C4RSM[2:0] are used to select the receiver sensitivity level and the monitor mode resistive gain. See [Table 6-16](#).

Bit 3: Receiver Transformer Turns Ratio Channel 3 (RTR3). If this bit is set the turns ratio is 1:1 on the receiver side. This bit should be set when a 1:1 receiver transformer is used. Note that in order to use the fully internal receive impedance termination, a 1:1 transformer must be used and this bit must be set to 1.

Bit 2 to 0: Channel 3 Receive Sensitivity/Monitor Select [2:0] (C3RSM[2:0]). Bits C3RSM[2:0] are used to select the receiver sensitivity level and the monitor mode resistive gain. See [Table 6-16](#).

Register Address (LIUs 9–16): **29h**

Bit #	7	6	5	4	3	2	1	0
Name	RTR12	C12RSM2	C12RSM1	C12RSM0	RTR11	C11RSM2	C11RSM1	C11RSM0
Default	0	0	0	0	0	0	0	0

Bit 7: Receiver Transformer Turns Ratio Channel 12 (RTR12). If this bit is set the turns ratio is 1:1 on the receiver side. This bit should be set when a 1:1 receiver transformer is used. Note that in order to use fully internal receive impedance termination, a 1:1 transformer must be used and this bit must be set to 1.

Bits 6 to 4: Channel 12 Receive Sensitivity/Monitor Select [2:0] (C12RSM[2:0]). Bits C12RSM[2:0] are used to select the receiver sensitivity level and the monitor mode resistive gain. See [Table 6-16](#).

Bit 3: Receiver Transformer Turns Ratio Channel 11 (RTR11). If this bit is set the turns ratio is 1:1 on the receiver side. This bit should be set when a 1:1 receiver transformer is used. Note that in order to use the fully internal receive impedance termination, a 1:1 transformer must be used and this bit must be set to 1.

Bits 2 to 0: Channel 11 Receive Sensitivity/Monitor Select [2:0] (C11RSM[2:0]). Bits C11RSM[2:0] are used to select the receiver sensitivity level and the monitor mode resistive gain. See [Table 6-16](#).

Register Name: **RSMM3**
 Register Description: **Receive Sensitivity Monitor Mode 3**
 Register Address (LIUs 1–8): **0Ah**

Bit #	7	6	5	4	3	2	1	0
Name	RTR6	C6RSM2	C6RSM1	C6RSM0	RTR5	C5RSM2	C5RSM1	C5RSM0
Default	0	0	0	0	0	0	0	0

Bit 7: Receiver Transformer Turns Ratio Channel 6 (RTR6). If this bit is set the turns ratio is 1:1 on the receiver side. This bit should be set when a 1:1 receiver transformer is used. Note that in order to use fully internal receive impedance termination, a 1:1 transformer must be used and this bit must be set to 1.

Bits 6 to 4: Channel 6 Receive Sensitivity/Monitor Select [2:0] (C6RSM[2:0]). Bits C6RSM[2:0] are used to select the receiver sensitivity level and the monitor mode resistive gain. See [Table 6-16](#).

Bit 3: Receiver Transformer Turns Ratio Channel 5 (RTR5). If this bit is set the turns ratio is 1:1 on the receiver side. This bit should be set when a 1:1 receiver transformer is used. Note that in order to use the fully internal receive impedance termination, a 1:1 transformer must be used and this bit must be set to 1.

Bits 2 to 0: Channel 5 Receive Sensitivity/Monitor Select [2:0] (C5RSM[2:0]). Bits C5RSM[2:0] are used to select the receiver sensitivity level and the monitor mode resistive gain. See [Table 6-16](#).

Register Address (LIUs 9–16): **2Ah**

Bit #	7	6	5	4	3	2	1	0
Name	RTR14	C14RSM2	C14RSM1	C14RSM0	RTR13	C13RSM2	C13RSM1	C13RSM0
Default	0	0	0	0	0	0	0	0

Bit 7: Receiver Transformer Turns Ratio Channel 14 (RTR14). If this bit is set the turns ratio is 1:1 on the receiver side. This bit should be set when a 1:1 receiver transformer is used. Note that in order to use fully internal receive impedance termination, a 1:1 transformer must be used and this bit must be set to 1.

Bits 6 to 4: Channel 14 Receive Sensitivity/Monitor Select [2:0] (C14RSM[2:0]). Bits C14RSM[2:0] are used to select the receiver sensitivity level and the monitor mode resistive gain. See [Table 6-16](#).

Bit 3: Receiver Transformer Turns Ratio Channel 13 (RTR13). If this bit is set the turns ratio is 1:1 on the receiver side. This bit should be set when a 1:1 receiver transformer is used. Note that in order to use the fully internal receive impedance termination, a 1:1 transformer must be used and this bit must be set to 1.

Bits 2 to 0: Channel 13 Receive Sensitivity/Monitor Select [2:0] (C13RSM[2:0]). Bits C13RSM[2:0] are used to select the receiver sensitivity level and the monitor mode resistive gain. See [Table 6-16](#).

Register Name: **RSMM4**
 Register Description: **Receive Sensitivity Monitor Mode 4**
 Register Address (LIUs 1–8): **0Bh**

Bit #	7	6	5	4	3	2	1	0
Name	RTR8	C8RSM2	C8RSM1	C8RSM0	RTR7	C7RSM2	C7RSM1	C7RSM0
Default	0	0	0	0	0	0	0	0

Bit 7: Receiver Transformer Turns Ratio Channel 8 (RTR8). If this bit is set the turns ratio is 1:1 on the receiver side. This bit should be set when a 1:1 receiver transformer is used. Note that in order to use fully internal receive impedance termination, a 1:1 transformer must be used and this bit must be set to 1.

Bits 6 to 4: Channel 8 Receive Sensitivity/Monitor Select [2:0] (C8RSM[2:0]). Bits C8RSM[2:0] are used to select the receiver sensitivity level and the monitor mode resistive gain. See [Table 6-16](#).

Bit 3: Receiver Transformer Turns Ratio Channel 7 (RTR7). If this bit is set the turns ratio is 1:1 on the receiver side. This bit should be set when a 1:1 receiver transformer is used. Note that in order to use the fully internal receive impedance termination, a 1:1 transformer must be used and this bit must be set to 1.

Bits 2 to 0: Channel 7 Receive Sensitivity/Monitor Select [2:0] (C7RSM[2:0]). Bits C7RSM[2:0] are used to select the receiver sensitivity level and the monitor mode resistive gain. See [Table 6-16](#).

Register Address (LIUs 9–16): **2Bh**

Bit #	7	6	5	4	3	2	1	0
Name	RTR16	C16RSM2	C16RSM1	C16RSM0	RTR15	C15RSM2	C15RSM1	C15RSM0
Default	0	0	0	0	0	0	0	0

Bit 7: Receiver Transformer Turns Ratio Channel 16 (RTR16). If this bit is set the turns ratio is 1:1 on the receiver side. This bit should be set when a 1:1 receiver transformer is used. Note that in order to use fully internal receive impedance termination, a 1:1 transformer must be used and this bit must be set to 1.

Bit 6 to 4: Channel 16 Receive Sensitivity/Monitor Select [2:0] (C16RSM[2:0]). Bits C16RSM[2:0] are used to select the receiver sensitivity level and the monitor mode resistive gain. See [Table 6-16](#).

Bit 3: Receiver Transformer Turns Ratio Channel 15 (RTR15). If this bit is set the turns ratio is 1:1 on the receiver side. This bit should be set when a 1:1 receiver transformer is used. Note that in order to use the fully internal receive impedance termination, a 1:1 transformer must be used and this bit must be set to 1.

Bits 2 to 0: Channel 15 Receive Sensitivity/Monitor Select [2:0] (C15RSM[2:0]). Bits C15RSM[2:0] are used to select the receiver sensitivity level and the monitor mode resistive gain. See [Table 6-16](#).

Table 6-16. Receiver Sensitivity/Monitor Mode Gain Selection

RECEIVER MONITOR MODE DISABLED	CnRSM[2:0], T1/E1 MODE	RECEIVER SENSITIVITY (MAXIMUM LOSS) (dB)	RECEIVER MONITOR MODE GAIN SETTINGS (dB)	LOSS DECLARATION LEVEL (dB)
No flat gain	000	12	0	15
No flat gain	001	18	0	21
Receiver monitor mode enabled	CnRSM[2:0]	Max cable loss	Receiver monitor mode gain settings	—
Flat gain	100	30	14	37
Flat gain	101	22.5	20	45.5

Register Name: **RSL1**
 Register Description: **Receive Signal Level Indicator 1**
 Register Address (LIUs 1–8): **0Ch**

Bit #	7	6	5	4	3	2	1	0
Name	<u>C2RSL3</u>	<u>C2RSL2</u>	<u>C2RSL1</u>	<u>C2RSL0</u>	<u>C1RSL3</u>	<u>C1RSL2</u>	<u>C1RSL1</u>	<u>C1RSL0</u>
Default	0	0	0	0	0	0	0	0

Bits 7 to 4: Channel 2 Receive Signal Level [3:0] (C2RSL[3:0]). C2RSL[3:0] bits provide the receive signal level as shown in [Table 6-17](#).

Bits 3 to 0: Channel 1 Receive Signal Level [3:0] (C1RSL[3:0]). C1RSL[3:0] bits provide the receive signal level as shown in [Table 6-17](#).

Register Address (LIUs 9–16): **2Ch**

Bit #	7	6	5	4	3	2	1	0
Name	<u>C10RSL3</u>	<u>C10RSL2</u>	<u>C10RSL1</u>	<u>C10RSL0</u>	<u>C9RSL3</u>	<u>C9RSL2</u>	<u>C9RSL1</u>	<u>C9RSL0</u>
Default	0	0	0	0	0	0	0	0

Bits 7 to 4: Channel 10 Receive Signal Level [3:0] (C10RSL[3:0]). C10RSL[3:0] bits provide the receive signal level as shown in [Table 6-17](#).

Bits 3 to 0: Channel 9 Receive Signal Level [3:0] (C9RSL[3:0]). C9RSL[3:0] bits provide the receive signal level as shown in [Table 6-17](#).

Table 6-17. Receiver Signal Level

CnRSL3 to CnRSL0	RECEIVE LEVEL (dB)	
	T1	E1
0000	>-2.5	>-2.5
0001	-2.5 to -5	-2.5 to -5
0010	-5 to -7.5	-5 to -7.5
0011	-7.5 to -10	-7.5 to -10
0100	-10 to -12.5	-10 to -12.5
0101	-12.5 to -15	-12.5 to -15
0110	-15 to -17.5	-15 to -17.5
0111	-17.5 to -20	-17.5 to -20

Register Name: **RSL2**
Register Description: **Receive Signal Level Indicator 2**
Register Address (LIUs 1–8): **0Dh**

Bit #	7	6	5	4	3	2	1	0
Name	<u>C4RSL3</u>	<u>C4RSL2</u>	<u>C4RSL1</u>	<u>C4RSL0</u>	<u>C3RSL3</u>	<u>C3RSL2</u>	<u>C3RSL1</u>	<u>C3RSL0</u>
Default	0	0	0	0	0	0	0	0

Bits 7 to 4: Channel 4 Receive Signal Level [3:0] (C4RSL[3:0]). C4RSL[3:0] bits provide the receive signal level as shown in [Table 6-17](#).

Bits 3 to 0: Channel 3 Receive Signal Level [3:0] (C3RSL[3:0]). C3RSL[3:0] bits provide the receive signal level as shown in [Table 6-17](#).

Register Address (LIUs 9–16): **2Dh**

Bit #	7	6	5	4	3	2	1	0
Name	<u>C12RSL3</u>	<u>C12RSL2</u>	<u>C12RSL1</u>	<u>C12RSL0</u>	<u>C11RSL3</u>	<u>C11RSL2</u>	<u>C11RSL1</u>	<u>C11RSL0</u>
Default	0	0	0	0	0	0	0	0

Bits 7 to 4: Channel 12 Receive Signal Level [3:0] (C12RSL[3:0]). C12RSL[3:0] bits provide the receive signal level as shown in [Table 6-17](#).

Bits 3 to 0: Channel 11 Receive Signal Level [3:0] (C11RSL[3:0]). C11RSL[3:0] bits provide the receive signal level as shown in [Table 6-17](#).

Register Name: **RSL3**
 Register Description: **Receive Signal Level Indicator 3**
 Register Address (LIUs 1–8): **0Eh**

Bit #	7	6	5	4	3	2	1	0
Name	<u>C6RSL3</u>	<u>C6RSL2</u>	<u>C6RSL1</u>	<u>C6RSL0</u>	<u>C5RSL3</u>	<u>C5RSL2</u>	<u>C5RSL1</u>	<u>C5RSL0</u>
Default	0	0	0	0	0	0	0	0

Bits 7 to 4: Channel 6 Receive Signal Level [3:0] (C6RSL[3:0]). C6RSL[3:0] bits provide the receive signal level as shown in [Table 6-17](#).

Bits 3 to 0: Channel 5 Receive Signal Level [3:0] (C5RSL[3:0]). C5RSL[3:0] bits provide the receive signal level as shown in [Table 6-17](#).

Register Address (LIUs 9–16): **2Eh**

Bit #	7	6	5	4	3	2	1	0
Name	<u>C14RSL3</u>	<u>C14RSL2</u>	<u>C14RSL1</u>	<u>C14RSL0</u>	<u>C13RSL3</u>	<u>C13RSL2</u>	<u>C13RSL1</u>	<u>C13RSL0</u>
Default	0	0	0	0	0	0	0	0

Bits 7 to 4: Channel 14 Receive Signal Level [3:0] (C14RSL[3:0]). C14RSL[3:0] bits provide the receive signal level as shown in [Table 6-17](#).

Bits 3 to 0: Channel 13 Receive Signal Level [3:0] (C13RSL[3:0]). C13RSL[3:0] bits provide the receive signal level as shown in [Table 6-17](#).

Register Name: **RSL4**
 Register Description: **Receive Signal Level Indicator 4**
 Register Address (LIUs 1–8): **0Fh**

Bit #	7	6	5	4	3	2	1	0
Name	<u>C8RSL3</u>	<u>C8RSL2</u>	<u>C8RSL1</u>	<u>C8RSL0/ CALSTAT</u>	<u>C7RSL3</u>	<u>C7RSL2</u>	<u>C7RSL1</u>	<u>C7RSL0</u>
Default	0	0	0	0	0	0	0	0

Bits 7 to 4: Channel 8 Receive Signal Level [3:0] (C8RSL[3:0]). C8RSL[3:0] bits provide the receive signal level as shown in [Table 6-17](#).

Bit 4: Channel 8 Receive Signal Level 0/Calibration Status (C8RSL0/CALSTAT). When CRIMP is high, C8RSL0 will be replaced by a real-time status bit for the receive internal termination calibration circuit. If the bit is low, this indicates that the calibration has not completed. If the bit is high, this indicates the calibration completed successfully. Normally this bit should go high within 7 μ s of the low-to-high transition of the CRIMP bit. Receive termination values will be updated subsequently.

Bits 3 to 0: Channel 7 Receive Signal Level [3:0] (C7RSL[3:0]). C7RSL[3:0] bits provide the receive signal level as shown in [Table 6-17](#).

Register Address (LIUs 9–16): **2Fh**

Bit #	7	6	5	4	3	2	1	0
Name	<u>C16RSL3</u>	<u>C16RSL2</u>	<u>C16RSL1</u>	<u>C16RSL0</u>	<u>C15RSL3</u>	<u>C15RSL2</u>	<u>C15RSL1</u>	<u>C15RSL0</u>
Default	0	0	0	0	0	0	0	0

Bits 7 to 4: Channel 16 Receive Signal Level [3:0] (C16RSL[3:0]). C16RSL[3:0] bits provide the receive signal level as shown in [Table 6-17](#).

Bits 3 to 0: Channel 15 Receive Signal Level [3:0] (C15RSL[3:0]). C15RSL[3:0] bits provide the receive signal level as shown in [Table 6-17](#).

Register Name: **BTCR**
 Register Description: **Bit Error Rate Tester Control**
 Register Address (LIUs 1–8): **10h**

Bit #	7	6	5	4	3	2	1	0
Name	BTS2	BTS1	BTS0	—	—	—	—	BERTE
Default	0	0	0	0	0	0	0	0

Note: This register enables the LIU1-LIU8 BERT. The BERT can only connect to one LIU at a time. The LIU1-LIU8 BERT operates independently of the LIU9-LIU16 BERT.

Bits 7 to 5: Bit Error Rate Transceiver Select [2:0] (BTS[2:0]). These bits BTS[2:0] select the LIU that the BERT applies to (see [Table 6-18](#)). This is only applicable if the BERTE bit is set.

Bit 0: Bit Error Rate Tester Enable (BERTE). When this bit is set and 2 μ s have past, the BERT will be enabled. The BERT register set should be written and read to only after being enabled. The BERT is only active for one LIU at a time selected by BTS[2:0]. This bit also forces the part into single-rail mode with HDB3/B8ZS encoding enabled.

Register Address (LIUs 9–16): **30h**

Bit #	7	6	5	4	3	2	1	0
Name	BTS2	BTS1	BTS0	—	—	—	—	BERTE
Default	0	0	0	0	0	0	0	0

Note: This register enables the LIU9-LIU16 BERT. The BERT can only connect to one LIU at a time. The LIU9-LIU16 BERT operates independently of the LIU1–LIU8 BERT.

Bits 7 to 5: Bit Error Rate Transceiver Select [2:0] (BTS[2:0]) These bits BTS[2:0] select the LIU that the BERT applies too (see [Table 6-19](#)). This is only applicable if the BERTE bit is set.

Bit 0: Bit Error Rate Tester Enable (BERTE). When this bit is set and 2 μ s have past, the BERT will be enabled. The BERT register set should be written and read to only after being enabled. The BERT is only active for one LIU at a time selected by BTS[2:0]. This bit also forces the part into single-rail mode with HDB3/B8ZS encoding enabled.

Table 6-18. Bit Error Rate Transceiver Select for Channels 1–8

REGISTER ADDRESS	BTS2	BTS1	BTS0	CHANNEL BERT APPLIES TO
10h	0	0	0	Channel 1
10h	0	0	0	Channel 2
10h	0	1	0	Channel 3
10h	0	1	1	Channel 4
10h	1	0	0	Channel 5
10h	1	0	1	Channel 6
10h	1	1	0	Channel 7
10h	1	1	1	Channel 8

Table 6-19. Bit Error Rate Transceiver Select for Channels 9–16

REGISTER ADDRESS	BTS2	BTS1	BTS0	CHANNEL BERT APPLIES TO
30h	0	0	0	Channel 9
30h	0	0	0	Channel 10
30h	0	1	0	Channel 11
30h	0	1	1	Channel 12
30h	1	0	0	Channel 13
30h	1	0	1	Channel 14
30h	1	1	0	Channel 15
30h	1	1	1	Channel 16

Register Name: **BEIR**
Register Description: **BPV Error Insertion**
Register Address (LIUs 1–8): **11h**

Bit #	7	6	5	4	3	2	1	0
Name	BEIR8	BEIR7	BEIR6	BEIR5	BEIR4	BEIR3	BEIR2	BEIR1
Default	0	0	0	0	0	0	0	0

Register Address (LIUs 9–16): **31h**

Bit #	7	6	5	4	3	2	1	0
Name	BEIR16	BEIR15	BEIR14	BEIR13	BEIR12	BEIR11	BEIR10	BEIR9
Default	0	0	0	0	0	0	0	0

Bits 7 to 0: BPV Error Insertion Register n (BEIR n). A 0-to-1 transition on this bit will cause a single bipolar violation (BPV) to be inserted into the transmit data stream Channel n . This bit must be cleared and set again for a subsequent error to be inserted. This is only applicable in single-rail mode.

Register Name: **LVDS**
 Register Description: **Line Violation Detect Status**
 Register Address (LIUs 1–8): **12h**

Bit #	7	6	5	4	3	2	1	0
Name	<u>LVDS8</u>	<u>LVDS7</u>	<u>LVDS6</u>	<u>LVDS5</u>	<u>LVDS4</u>	<u>LVDS3</u>	<u>LVDS2</u>	<u>LVDS1</u>
Default	0	0	0	0	0	0	0	0

Register Address (LIUs 9–16): **32h**

Bit #	7	6	5	4	3	2	1	0
Name	<u>LVDS16</u>	<u>LVDS15</u>	<u>LVDS14</u>	<u>LVDS13</u>	<u>LVDS12</u>	<u>LVDS11</u>	<u>LVDS10</u>	<u>LVDS9</u>
Default	0	0	0	0	0	0	0	0

Bits 7 to 0: Line Violation Detect Status n (LVDS n). A bipolar violation, a code violation, or excessive zeros will cause the associated LVDS n bit to latch. This bit will be cleared on a read operation. The LVDS register captures the first violation within a three clock period window. If a second violation occurs after the first violation within the three clock period window, then the second violation will not be latched even if a read to the LVDS register was performed. Excessive zeros need to be enabled by the [EZDE](#) register for detection by this register. Code violations are only relevant when in HDB3 mode and can be disabled for detection by this register by setting the [CVDEB](#) register.

Register Name: **RCLKI**
 Register Description: **Receive Clock Invert**
 Register Address (LIUs 1–8): **13h**

Bit #	7	6	5	4	3	2	1	0
Name	RCLKI8	RCLKI7	RCLKI6	RCLKI5	RCLKI4	RCLKI3	RCLKI2	RCLKI1
Default	0	0	0	0	0	0	0	0

Register Address (LIUs 9–16): **33h**

Bit #	7	6	5	4	3	2	1	0
Name	RCLKI16	RCLKI15	RCLKI14	RCLKI13	RCLKI12	RCLKI11	RCLKI10	RCLKI9
Default	0	0	0	0	0	0	0	0

Bit 7 to 0: Receive Clock Invert n (RCLKI n). When this bit is set the RCLK for Channel n is inverted. This aligns RPOS/RNEG on the falling edge of RCLK. When reset or default RPOS/RNEG is aligned on the rising edge of RCLK.

Register Name: **TCLKI**
 Register Description: **Transmit Clock Invert**
 Register Address (LIUs 1–8): **14h**

Bit #	7	6	5	4	3	2	1	0
Name	TCLKI8	TCLKI7	TCLKI6	TCLKI5	TCLKI4	TCLKI3	TCLKI2	TCLKI1
Default	0	0	0	0	0	0	0	0

Register Address (LIUs 9–16): **34h**

Bit #	7	6	5	4	3	2	1	0
Name	TCLKI16	TCLKI15	TCLKI14	TCLKI13	TCLKI12	TCLKI11	TCLKI10	TCLKI9
Default	0	0	0	0	0	0	0	0

Bits 7 to 0: Transmit Clock Invert n (TCLKIn). When this bit is set the expected TCLK for Channel n is inverted. TPOS/TNEG should be aligned on the falling edge of TCLK. When reset or default TPOS/TNEG should be aligned on the rising edge of TCLK.

Register Name: **CCR**
 Register Description: **Clock Control**
 Register Address: **15h**

Bit #	7	6	5	4	3	2	1	0
Name	PCLKS2	PCLKS1	PCLKS0	TECLKS	CLKA3	CLKA2	CLKA1	CLKA0
Default	0	0	0	0	0	0	0	0

Bits 7 to 5: PLL Clock Select (PCLKS[2:0]). These bits determine the RCLK that is to be used as the input to the PLL. If an LOS is detect for the channel that RCLK is recovered from, the PLL will switch to MCLK until the LOS is cleared. When the LOS is cleared RCLK will be used again. See [Table 6-20](#) for RCLK selection. [MC.PCLKI\[1:0\]](#) must be set to '01' or '10' in order for these settings to take effect.

Table 6-20. PLL Clock Select

PCLKS[2:0]	PLL CLOCK SELECTED MC.PCLKI[1:0]=01	PLL CLOCK SELECTED MC.PCLKI[1:0]=10
000	RCLK1	RCLK9
001	RCLK2	RCLK10
010	RCLK3	RCLK11
011	RCLK4	RCLK12
100	RCLK5	RCLK13
101	RCLK6	RCLK14
110	RCLK7	RCLK15
111	RCLK8	RCLK16

Bit 4: T1/E1 Clock Select (TECLKS). When this bit is set the T1/E1 clock output is 2.048MHz. When this bit is reset the T1/E1 clock rate is 1.544MHz

Bits 3 to 0: Clock A Select (CLKA[3:0]). These bits select the output frequency for CLKA pin. See [Table 6-21](#) for available frequencies. For best jitter performance, select MCLK as the source for CLKA and input a 2.048MHz MCLK.

Table 6-21. Clock A Select

CLKA[3:0]	CLKA (Hz)
0000	2.048M
0001	4.096M
0010	8.192M
0011	16.384M
0100	1.544M
0101	3.088M
0110	6.176M
0111	12.352M
1000	1.536M
1001	3.072M
1010	6.144M
1011	12.288M
1100	32k
1101	64k
1110	128k
1111	256k

Register Name: **RDULR**
 Register Description: **RCLK Disable Upon LOS**
 Register Address (LIUs 1–8): **16h**

Bit #	7	6	5	4	3	2	1	0
Name	RDULR8	RDULR7	RDULR6	RDULR5	RDULR4	RDULR3	RDULR2	RDULR1
Default	0	0	0	0	0	0	0	0

Register Address (LIUs 9–16): **36h**

Bit #	7	6	5	4	3	2	1	0
Name	RDULR16	RDULR15	RDULR14	RDULR13	RDULR12	RDULR11	RDULR10	RDULR9
Default	0	0	0	0	0	0	0	0

Bits 7 to 0: RCLK Disable Upon LOS Register n (RDULR n). When this bit is set the RCLK for Channel n is disabled upon a loss of signal and set as a low output. When reset or default RCLK will switch to MCLK upon a loss of signal within 10ms.

Register Name: **GISC**
 Register Description: **Global Interrupt Status Control**
 Register Address: **1Eh**

Bit #	7	6	5	4	3	2	1	0
Name	—	—	—	—	—	—	INTM	CWE
Default	0	0	0	0	0	0	0	0

Bit 1: INT Pin Mode (INTM). This bit determines the inactive mode of the $\overline{\text{INT}}$ pin. The $\overline{\text{INT}}$ pin always drives low when active.

0 = Pin is high impedance when not active.

1 = Pin drives high when not active.

Bit 0: Clear On Write Enable (CWE). When this bit is set the clear on write is enabled for all the latched interrupt status registers. The host processor must write a 1 to the latched interrupt status register bit position before the particular bit will be cleared. Default for all the latched interrupt status registers is to clear on a read.

6.1.4 BERT Registers

Register Name: **BCR**
 Register Description: **BERT Control**
 Register Address (LIUs 1–8): **00h**
 Register Address (LIUs 9–16): **20h**

Bit #	7	6	5	4	3	2	1	0
Name	PMUM	LPMU	RNPL	RPIC	MPR	APRD	TNPL	TPIC
Default	0	0	0	0	0	0	0	0

Bit 7: Performance Monitoring Update Mode (PMUM). When 0, a performance monitoring update is initiated by the LPMU register bit. When 1, a performance monitoring update is initiated by the receive performance monitoring update signal (RPMU). Note: If RPMU or LPMU is one, changing the state of this bit may cause a performance monitoring update to occur.

Bit 6: Local Performance Monitoring Update (LPMU). This bit causes a performance monitoring update to be initiated if local performance monitoring update is enabled (PMUM = 0). A 0-to-1 transition causes the performance monitoring registers to be updated with the latest data, and the counters reset (0 or 1). For a second performance monitoring update to be initiated, this bit must be set to 0, and back to 1. If LPMU goes low before the PMS bit goes high, an update might not be performed. This bit has no affect when PMUM = 1.

Bit 5: Receive New Pattern Load (RNPL). A 0-to-1 transition of this bit will cause the programmed test pattern (QRSS, PTS, PLF[4:0], PTF[4:0], and BSP[31:0]) to be loaded in to the receive pattern generator. This bit must be changed to zero and back to one for another pattern to be loaded. Loading a new pattern will forces the receive pattern generator out of the “Sync” state which causes a resynchronization to be initiated. Note: QRSS, PTS, PLF[4:0], PTF[4:0], and BSP[31:0] must not change from the time this bit transitions from 0 to 1 until four RXCK clock cycles after this bit transitions from 0 to 1.

Bit 4: Receive Pattern Inversion Control (RPIC). When 0, the receive incoming data stream is not altered. When 1, the receive incoming data stream is inverted.

Bit 3: Manual Pattern Resynchronization (MPR). A zero to one transition of this bit will cause the receive pattern generator to resynchronize to the incoming pattern. This bit must be changed to zero and back to one for another resynchronization to be initiated. Note: A manual resynchronization forces the receive pattern generator out of the “Sync” state.

Bit 2: Automatic Pattern Resynchronization Disable (APRD). When 0, the receive pattern generator will automatically resynchronize to the incoming pattern if six or more times during the current 64-bit window the incoming data stream bit and the receive pattern generator output bit did not match. When 1, the receive pattern generator will not automatically resynchronize to the incoming pattern. Note: Automatic synchronization is prevented by not allowing the receive pattern generator to automatically exit the “Sync” state.

Bit 1: Transmit New Pattern Load (TNPL). A 0-to-1 transition of this bit will cause the programmed test pattern (QRSS, PTS, PLF[4:0], PTF[4:0], and BSP[31:0]) to be loaded in to the transmit pattern generator. This bit must be changed to zero and back to one for another pattern to be loaded. Note: QRSS, PTS, PLF[4:0], PTF[4:0], and BSP[31:0] must not change from the time this bit transitions from 0 to 1 until four TXCK clock cycles after this bit transitions from 0 to 1.

Bit 0: Transmit Pattern Inversion Control (TPIC). When 0, the transmit outgoing data stream is not altered. When 1, the transmit outgoing data stream is inverted.

Register Name: **BPCR1**
 Register Description: **BERT Pattern Configuration Register 1**
 Register Address (LIUs 1–8): **02h**
 Register Address (LIUs 9–16): **22h**

Bit #	7	6	5	4	3	2	1	0
Name	—	QRSS	PTS	PLF4	PLF3	PLF2	PLF1	PLF0
Default	0	0	0	0	0	0	0	0

Bit 6: QRSS Enable (QRSS). When 0, the pattern generator configuration is controlled by PTS, PLF[4:0], and PTF[4:0], and BSP[31:0]. When 1, the pattern generator configuration is forced to a PRBS pattern with a generating polynomial of $x^{20} + x^{17} + 1$. The output of the pattern generator will be forced to one if the next fourteen output bits are all zero.

Bit 5: Pattern Type Select (PTS). When 0, the pattern is a PRBS pattern. When 1, the pattern is a repetitive pattern.

Bits 4 to 0: Pattern Length Feedback (PLF[4:0]). These five bits control the “length” feedback of the pattern generator. The “length” feedback will be from bit n of the pattern generator ($n = \text{PLF}[4:0] + 1$). For a PRBS signal, the feedback is an XOR of bit n and bit y . For a repetitive pattern the feedback is bit n .

Register Name: **BPCR2**
 Register Description: **BERT Pattern Configuration Register 2**
 Register Address (LIUs 1–8): **03h**
 Register Address (LIUs 9–16): **23h**

Bit #	7	6	5	4	3	2	1	0
Name	—	—	—	PTF4	PTF3	PTF2	PTF1	PTF0
Default	0	0	0	0	0	0	0	0

Bits 4 to 0: Pattern Tap Feedback (PTF[4:0]). These five bits control the PRBS “tap” feedback of the pattern generator. The “tap” feedback will be from bit y of the pattern generator ($y = \text{PTF}[4:0] + 1$). These bits are ignored when programmed for a repetitive pattern. For a PRBS signal, the feedback is an XOR of bit n and bit y .

Register Name: **BSPR1**
 Register Description: **BERT Seed/Pattern Register 1**
 Register Address (LIUs 1–8): **04h**
 Register Address (LIUs 9–16): **24h**

Bit #	7	6	5	4	3	2	1	0
Name	BSP7	BSP6	BSP5	BSP4	BSP3	BSP2	BSP1	BSP0
Default	0	0	0	0	0	0	0	0

Register Name: **BSPR2**
 Register Description: **BERT Seed/Pattern Register 2**
 Register Address (LIUs 1–8): **05h**
 Register Address (LIUs 9–16): **25h**

Bit #	7	6	5	4	3	2	1	0
Name	BSP15	BSP14	BSP13	BSP12	BSP11	BSP10	BSP9	BSP8
Default	0	0	0	0	0	0	0	0

Register Name: **BSPR3**
 Register Description: **BERT Seed/Pattern Register 3**
 Register Address (LIUs 1–8): **06h**
 Register Address (LIUs 9–16): **26h**

Bit #	7	6	5	4	3	2	1	0
Name	BSP23	BSP22	BSP21	BSP20	BSP19	BSP18	BSP17	BSP16
Default	0	0	0	0	0	0	0	0

Register Name: **BSPR4**
 Register Description: **BERT Seed/Pattern Register 4**
 Register Address (LIUs 1–8): **07h**
 Register Address (LIUs 9–16): **27h**

Bit #	7	6	5	4	3	2	1	0
Name	BSP31	BSP30	BSP29	BSP28	BSP27	BSP26	BSP25	BSP24
Default	0	0	0	0	0	0	0	0

Bits 31 to 0: BERT Seed/Pattern (BSP[31:0]). These 32 bits are the programmable seed for a transmit PRBS pattern, or the programmable pattern for a transmit or receive repetitive pattern. BSP(31) will be the first bit output on the transmit side for a 32-bit repetitive pattern or 32-bit length PRBS. BSP(31) will be the first bit input on the receive side for a 32-bit repetitive pattern.

Register Name: **TEICR**
 Register Description: **Transmit Error Insertion Control Register**
 Register Address (LIUs 1–8): **08h**
 Register Address (LIUs 9–16): **28h**

Bit #	7	6	5	4	3	2	1	0
Name	—	—	TEIR2	TEIR1	TEIR0	BEI	TSEI	MEIMS
Default	0	0	0	0	0	0	0	0

Bits 5 to 3: Transmit Error Insertion Rate (TEIR[2:0]). These three bits indicate the rate at which errors are inserted in the output data stream. One out of every 10^n bits is inverted. TEIR[2:0] is the value n . A TEIR[2:0] value of 0 disables error insertion at a specific rate. A TEIR[2:0] value of 1 result in every 10th bit being inverted. A TEIR[2:0] value of 2 result in every 100th bit being inverted. Error insertion starts when this register is written to with a TEIR[2:0] value that is nonzero. If this register is written to during the middle of an error insertion process, the new error rate will be started after the next error is inserted.

Bit 2: Bit Error Insertion Enable (BEI). When 0, single bit error insertion is disabled. When 1, single bit error insertion is enabled.

Bit 1: Transmit Single Error Insert (TSEI). This bit causes a bit error to be inserted in the transmit data stream if manual error insertion is disabled (MEIMS = 0) and single bit error insertion is enabled. A 0 to 1 transition causes a single bit error to be inserted. For a second bit error to be inserted, this bit must be set to 0, and back to 1. Note: If MEIMS is low, and this bit transitions more than once between error insertion opportunities, only one error will be inserted.

Bit 0: Manual Error Insert Mode Select (MEIMS). When 0, error insertion is initiated by the TSEI register bit. When 1, error insertion is initiated by the transmit manual error insertion signal (TMEI). Note: If TMEI or TSEI is one, changing the state of this bit may cause a bit error to be inserted.

Register Name: **BSR**
 Register Description: **BERT Status**
 Register Address (LIUs 1–8): **0Ch**
 Register Address (LIUs 9–16): **2Ch**

Bit #	7	6	5	4	3	2	1	0
Name	—	—	—	—	PMS	—	BEC	OOS
Default	0	0	0	0	0	0	0	0

Bit 3: Performance Monitoring Update Status (PMS). This bit indicates the status of the receive performance monitoring register (counters) update. This bit will transition from low to high when the update is completed. PMS is asynchronously forced low when the LPMU bit (PMUM = 0) or RPMU signal (PMUM=1) goes low.

Bit 1: Bit Error Count (BEC). When 0, the bit error count is zero. When 1, the bit error count is one or more.

Bit 0: Out Of Synchronization (OOS). When 0, the receive pattern generator is synchronized to the incoming pattern. When 1, the receive pattern generator is not synchronized to the incoming pattern.

Register Name: **BSRL**
 Register Description: **BERT Status Register Latched**
 Register Address (LIUs 1–8): **0Eh**
 Register Address (LIUs 9–16): **2Eh**

Bit #	7	6	5	4	3	2	1	0
Name	—	—	—	—	<u>PMSL</u>	<u>BEL</u>	<u>BECL</u>	<u>OOSL</u>
Default	0	0	0	0	0	0	0	0

Bit 3: Performance Monitoring Update Status Latched (PMSL). This bit is set when the PMS bit transitions from 0 to 1. A read operation clears this bit.

Bit 2: Bit Error Latched (BEL). This bit is set when a bit error is detected. A read operation clears this bit.

Bit 1: Bit Error Count Latched (BECL). This bit is set when the BEC bit transitions from 0 to 1. A read operation clears this bit.

Bit 0: Out Of Synchronization Latched (OOSL). This bit is set when the OOS bit changes state. A read operation clears this bit.

Register Name: **BSRIE**
 Register Description: **BERT Status Register Interrupt Enable**
 Register Address (LIUs 1–8): **10h**
 Register Address (LIUs 9–16): **30h**

Bit #	7	6	5	4	3	2	1	0
Name	—	—	—	—	PMSIE	BEIE	BECIE	OOSIE
Default	0	0	0	0	0	0	0	0

Bit 3: Performance Monitoring Update Status Interrupt Enable (PMSIE). This bit enables an interrupt if the PMSL bit is set.

0 = interrupt disabled
 1 = interrupt enabled

Bit 2: Bit Error Interrupt Enable (BEIE). This bit enables an interrupt if the BEL bit is set.

0 = interrupt disabled
 1 = interrupt enabled

Bit 1: Bit Error Count Interrupt Enable (BECIE). This bit enables an interrupt if the BECL bit is set.

0 = interrupt disabled
 1 = interrupt enabled

Bit 0: Out Of Synchronization Interrupt Enable (OOSIE). This bit enables an interrupt if the OOSL bit is set.

0 = interrupt disabled
 1 = interrupt enabled

Register Name: **RBECR1**
 Register Description: **Receive BERT Bit Error Count Register 1**
 Register Address (LIUs 1–8): **14h**
 Register Address (LIUs 9–16): **34h**

Bit #	7	6	5	4	3	2	1	0
Name	<u>BEC7</u>	<u>BEC6</u>	<u>BEC5</u>	<u>BEC4</u>	<u>BEC3</u>	<u>BEC2</u>	<u>BEC1</u>	<u>BEC0</u>
Default	0	0	0	0	0	0	0	0

Register Name: **RBECR2**
 Register Description: **Receive BERT Bit Error Count Register 2**
 Register Address (LIUs 1–8): **15h**
 Register Address (LIUs 9–16): **35h**

Bit #	7	6	5	4	3	2	1	0
Name	<u>BEC15</u>	<u>BEC14</u>	<u>BEC13</u>	<u>BEC12</u>	<u>BEC11</u>	<u>BEC10</u>	<u>BEC9</u>	<u>BEC8</u>
Default	0	0	0	0	0	0	0	0

Register Name: **RBECR3**
 Register Description: **Receive BERT Bit Error Count Register 3**
 Register Address (LIUs 1–8): **16h**
 Register Address (LIUs 9–16): **36h**

Bit #	7	6	5	4	3	2	1	0
Name	<u>BEC23</u>	<u>BEC22</u>	<u>BEC21</u>	<u>BEC20</u>	<u>BEC19</u>	<u>BEC18</u>	<u>BEC17</u>	<u>BEC16</u>
Default	0	0	0	0	0	0	0	0

Bits 23 to 0: BERT Bit Error Count (BEC[23:0]). These 24 bits indicate the number of bit errors detected in the incoming data stream. This count stops incrementing when it reaches a count of FF FFFFh. The associated bit error counter will not be incremented when an OOS condition exists.

Register Name: **RBCR1**
 Register Description: **Receive BERT Bit Count Register 1**
 Register Address (LIUs 1–8): **18h**
 Register Address (LIUs 9–16): **38h**

Bit #	7	6	5	4	3	2	1	0
Name	<u>BC7</u>	<u>BC6</u>	<u>BC5</u>	<u>BC4</u>	<u>BC3</u>	<u>BC2</u>	<u>BC1</u>	<u>BC0</u>
Default	0	0	0	0	0	0	0	0

Register Name: **RBCR2**
 Register Description: **Receive BERT Bit Count Register 2**
 Register Address (LIUs 1–8): **19h**
 Register Address (LIUs 9–16): **39h**

Bit #	15	14	13	12	11	10	9	8
Name	<u>BC15</u>	<u>BC14</u>	<u>BC13</u>	<u>BC12</u>	<u>BC11</u>	<u>BC10</u>	<u>BC9</u>	<u>BC8</u>
Default	0	0	0	0	0	0	0	0

Register Name: **RBCR3**
 Register Description: **Receive BERT Bit Count Register 3**
 Register Address (LIUs 1–8): **1Ah**
 Register Address (LIUs 9–16): **3Ah**

Bit #	7	6	5	4	3	2	1	0
Name	<u>BC23</u>	<u>BC22</u>	<u>BC21</u>	<u>BC20</u>	<u>BC19</u>	<u>BC18</u>	<u>BC17</u>	<u>BC16</u>
Default	0	0	0	0	0	0	0	0

Register Name: **RBCR4**
 Register Description: **Receive BERT Bit Count Register 4**
 Register Address (LIUs 1–8): **1Bh**
 Register Address (LIUs 9–16): **3Bh**

Bit #	15	14	13	12	11	10	9	8
Name	<u>BC31</u>	<u>BC30</u>	<u>BC29</u>	<u>BC28</u>	<u>BC27</u>	<u>BC26</u>	<u>BC25</u>	<u>BC24</u>
Default	0	0	0	0	0	0	0	0

Bits 31 to 0: BERT Bit Count (BC[31:0]). These 32 bits indicate the number of bits in the incoming data stream. This count stops incrementing when it reaches a count of FFFF FFFFh. The associated bit counter will not be incremented when an OOS condition exists.

7 JTAG BOUNDARY SCAN ARCHITECTURE AND TEST ACCESS PORT

The DS26324 IEEE 1149.1 design supports the standard instruction codes SAMPLE/PRELOAD, BYPASS, and EXTEST. Optional public instructions included are HIGHZ, CLAMP, and IDCODE. The DS26324 contains the following as required by IEEE 1149.1 Standard Test-Access Port and Boundary-Scan Architecture:

Test Access Port (TAP)
TAP Controller
Instruction Register

Bypass Register
Boundary Scan Register
Device Identification Register

Details on Boundary Scan Architecture and the Test Access Port can be found in IEEE 1149.1-1990, IEEE 1149.1a-1993, and IEEE 1149.1b-1994. The Test Access Port has the necessary interface pins: TRSTB, TCLK, TMS, TDI, and TDO. See the pin descriptions for details. For the latest BSDL files go to www.maxim-ic.com/tools/bsdl/ and search for DS26324.

Figure 7-1. JTAG Functional Block Diagram

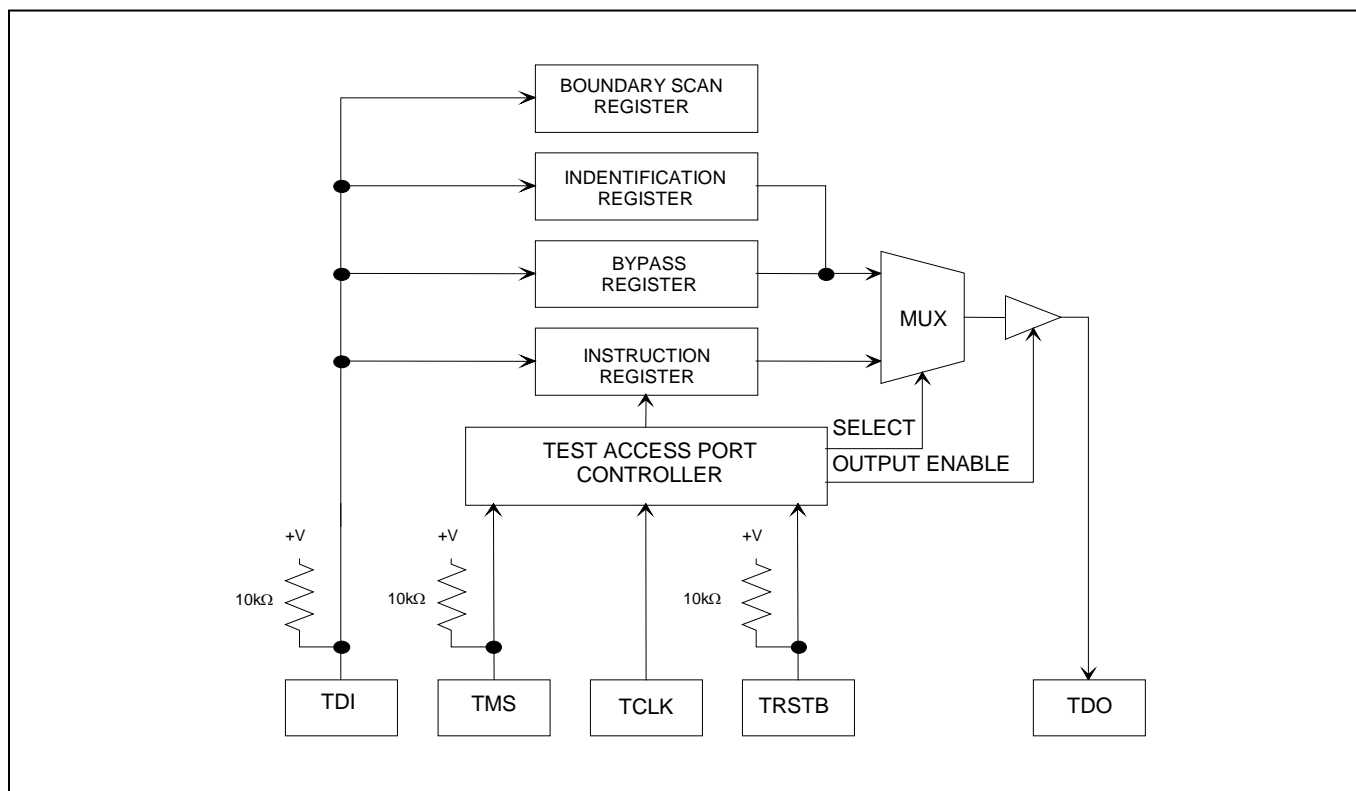

7.1 TAP Controller State Machine

The TAP controller is a finite state machine that responds to the logic level at TMS on the rising edge of TCLK. The state diagram is shown in [Figure 7-2](#).

7.1.1 Test-Logic-Reset

Upon power-up, the TAP controller will be in the Test-Logic-Reset state. The instruction register will contain the IDCODE instruction. All system logic of the device will operate normally. This state is automatically entered during power-up. This state is entered from any state if the TMS is held high for at least 5 clocks.

7.1.2 Run-Test-Idle

The Run-Test-Idle is used between scan operations or during specific tests. The instruction register and test registers will remain idle. The controller remains in this state when TMS is held low. When the TMS is high and rising edge of TCLK is applied the controller moves to the Select-DR-Scan state.

7.1.3 Select-DR-Scan

All test registers retain their previous state. With TMS LOW, a rising edge of TCLK moves the controller into the Capture-DR state and will initiate a scan sequence. TMS HIGH during a rising edge on TCLK moves the controller to the Select-IR-Scan state.

7.1.4 Capture-DR

Data can be parallel-loaded into the test-data registers if the current instruction is EXTEST or SAMPLE/PRELOAD. If the instruction does not call for a parallel load or the selected register does not allow parallel loads, the test register will remain at its current value. On the rising edge of TCLK, the controller will go to the shift-DR state if TMS is LOW or it will go to the exit1-DR state if TMS is HIGH.

7.1.5 Shift-DR

The test-data register selected by the current instruction will be connected between TDI and TDO and will shift data one stage towards its serial output on each rising edge of TCLK. If a test register selected by the current instruction is not placed in the serial path, it will maintain its previous state. When the TAP controller is in this state and a rising edge of TCLK is applied, the controller enters the Exit1-DR state if TMS is high or remains in Shift-DR state if TMS is low.

7.1.6 Exit1-DR

While in this state, a rising edge on TCLK will put the controller in the Update-DR state, which terminates the scanning process, if TMS is HIGH. A rising edge on TCLK with TMS LOW will put the controller in the Pause-DR state.

7.1.7 Pause-DR

Shifting of the test registers is halted while in this state. All test registers selected by the current instruction will retain their previous state. The controller will remain in this state while TMS is LOW. A rising edge on TCLK with TMS HIGH will put the controller in the Exit2-DR state.

7.1.8 Exit2-DR

A rising edge on TCLK with TMS HIGH while in this state will put the controller in the Update-DR state and terminate the scanning process. A rising edge on TCLK with TMS LOW will enter the Shift-DR state.

7.1.9 Update-DR

A falling edge on TCLK while in the Update-DR state will latch the data from the shift register path of the test registers into the data output latches. This prevents changes at the parallel output due to changes in the shift register.

7.1.10 Select-IR-Scan

All test registers retain their previous state. The instruction register will remain unchanged during this state. With TMS LOW, a rising edge on TCLK moves the controller into the Capture-IR state and will initiate a scan sequence for the instruction register. TMS HIGH during a rising edge on TCLK puts the controller back into the Test-Logic-Reset state.

7.1.11 Capture-IR

The Capture-IR state is used to load the shift register in the instruction register with a fixed value. This value is loaded on the rising edge of TCLK. If TMS is HIGH on the rising edge of TCLK, the controller will enter the Exit1-IR state. If TMS is LOW on the rising edge of TCLK, the controller will enter the Shift-IR state.

7.1.12 Shift-IR

In this state, the shift register in the instruction register is connected between TDI and TDO and shifts data one stage for every rising edge of TCLK towards the serial output. The parallel registers as well as all test registers remain at their previous states. A rising edge on TCLK with TMS HIGH will move the controller to the Exit1-IR state. A rising edge on TCLK with TMS LOW will keep the controller in the Shift-IR state while moving data one stage through the instruction shift register.

7.1.13 Exit1-IR

A rising edge on TCLK with TMS LOW will put the controller in the pause-IR state. If TMS is HIGH on the rising edge of TCLK, the controller will enter the update-IR state and terminate the scanning process.

7.1.14 Pause-IR

Shifting of the instruction shift register is halted temporarily. With TMS HIGH, a rising edge on TCLK will put the controller in the Exit2-IR state. The controller will remain in the Pause-IR state if TMS is LOW during a rising edge on TCLK.

7.1.15 Exit2-IR

A rising edge on TCLK with TMS HIGH will put the controller in the Update-IR state. The controller will loop back to Shift-IR if TMS is LOW during a rising edge of TCLK in this state.

7.1.16 Update-IR

The instruction code shifted into the instruction shift register is latched into the parallel output on the falling edge of TCLK as the controller enters this state. Once latched, this instruction becomes the current instruction. A rising edge on TCLK with TMS LOW will put the controller in the Run-Test-Idle state. With TMS HIGH, the controller will enter the Select-DR-Scan state.

Figure 7-2. TAP Controller State Diagram

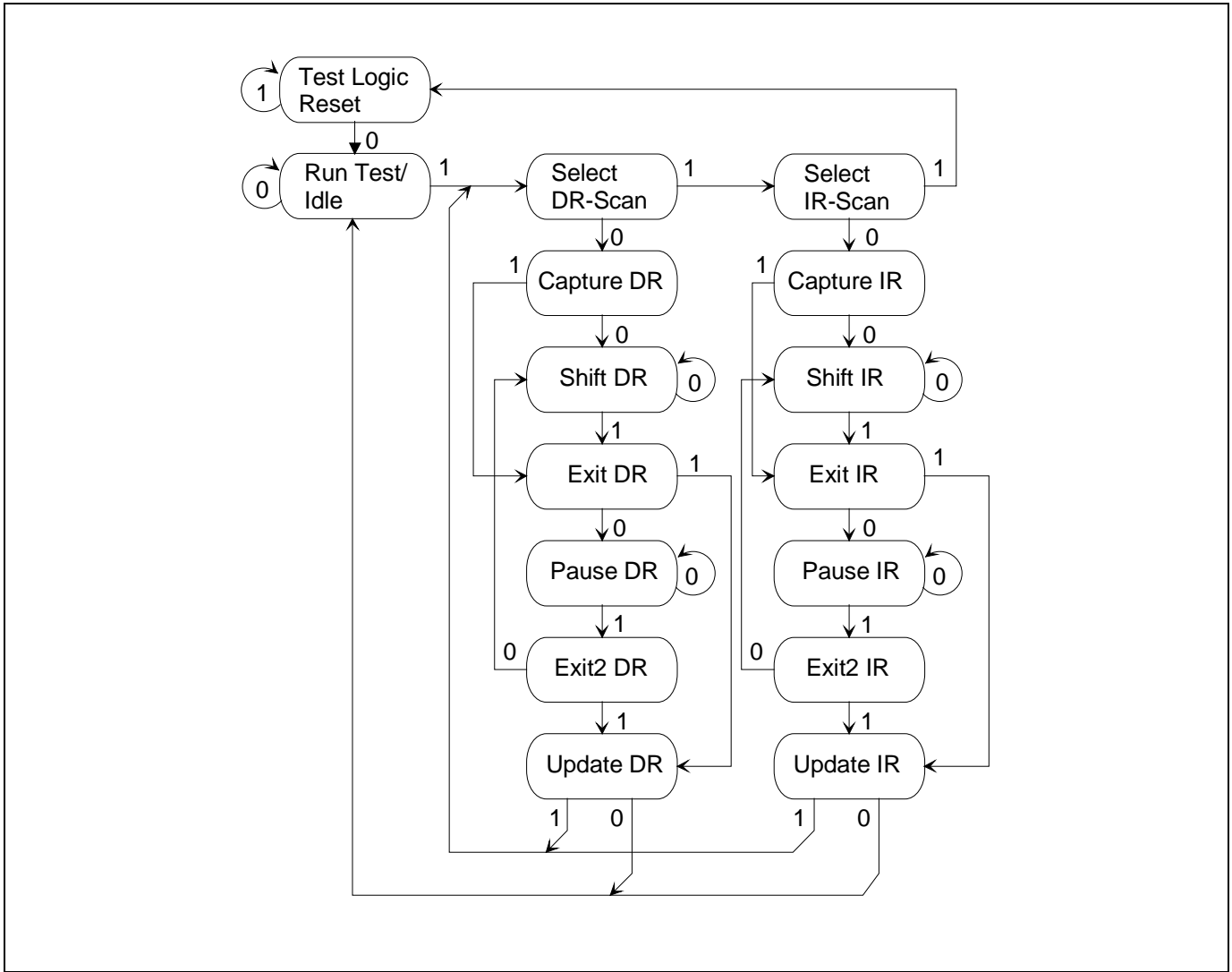

7.2 Instruction Register

The instruction register contains a shift register as well as a latched parallel output and is 3 bits in length. When the TAP controller enters the Shift-IR state, the instruction shift register will be connected between TDI and TDO. While in the Shift-IR state, a rising edge on TCLK with TMS LOW will shift the data one stage towards the serial output at TDO. A rising edge on TCLK in the Exit1-IR state or the Exit2-IR state with TMS HIGH will move the controller to the update-IR state. The falling edge of that same TCLK will latch the data in the instruction shift register to the instruction parallel output. Instructions supported by the DS26324 and its respective operational binary codes are shown in [Table 7-1](#).

Table 7-1. Instruction Codes for IEEE 1149.1 Architecture

INSTRUCTION	SELECTED REGISTER	INSTRUCTION CODES
EXTEST	Boundary Scan	000
HIGHZ	Bypass	010
CLAMP	Bypass	011
SAMPLE/PRELOAD	Boundary Scan	100
IDCODE	Device Identification	110
BYPASS	Bypass	111

7.2.1 EXTEST

This allows testing of all interconnections to the device. When the EXTEST instruction is latched in the instruction register, the following actions occur. Once enabled via the Update-IR state, the parallel outputs of all digital output pins will be driven. The Boundary Scan Register will be connected between TDI and TDO. The Capture-DR will sample all digital inputs into the Boundary Scan Register.

7.2.2 HIGHZ

All digital outputs of the device will be placed in a high-impedance state. The Bypass Register will be connected between TDI and TDO.

7.2.3 CLAMP

All digital outputs of the device will output data from the boundary scan parallel output while connecting the Bypass Register between TDI and TDO. The outputs will not change during the CLAMP instruction.

7.2.4 SAMPLE/PRELOAD

This is a mandatory instruction for the IEEE 1149.1 specification that supports two functions. The digital I/Os of the device can be sampled at the Boundary Scan Register without interfering with the normal operation of the device by using the Capture-DR state. SAMPLE/PRELOAD also allows the device to shift data into the Boundary Scan Register via TDI using the Shift-DR state.

7.2.5 IDCODE

When the IDCODE instruction is latched into the Parallel Instruction Register, the Identification Test Register is selected. The device identification code will be loaded into the Identification Register on the rising edge of TCLK following entry into the Capture-DR state. Shift-DR can be used to shift the identification code out serially via TDO. During Test-Logic-Reset, the identification code is forced into the Instruction Register's parallel output. The ID code will always have a 1 in the LSB position. The next 11 bits identify the manufacturer's JEDEC number and number of continuation bytes followed by 16 bits for the device and 4 bits for the version [Table 7-2](#). [Table 7-3](#) lists the device ID code for the DS26324.

7.2.6 BYPASS

When the BYPASS instruction is latched into the Parallel Instruction Register, TDI connects to TDO through the one-bit test Bypass Register. This allows data to pass from TDI to TDO not affecting the device's normal operation.

Table 7-2. ID Code Structure

MSB		LSB	
Version	Device ID	JEDEC	1
Contact Factory			
4 bits	16 bits	00010100001	1

Table 7-3. Device ID Codes

DEVICE	16-BIT ID
DS26324	003Ch

7.3 Test Registers

IEEE 1149.1 requires a minimum of two test registers: the Bypass Register and the Boundary Scan Register. An optional test register has been included with the DS26324 design. This test register is the Identification Register and is used with the IDCODE instruction and the Test-Logic-Reset state of the TAP controller.

7.3.1 Boundary Scan Register

This register contains both a shift register path and a latched parallel output for all control cells and digital I/O cells and is n bits in length.

7.3.2 Bypass Register

This register is a single 1-bit shift register used with the BYPASS, CLAMP, and HIGHZ instructions that provide a short path between TDI and TDO.

7.3.3 Identification Register

The Identification Register contains a 32-bit shift register and a 32-bit latched parallel output. This register is selected during the IDCODE instruction and when the TAP controller is in the Test-Logic-Reset state. See [Table 7-2](#) and [Table 7-3](#) for more information about bit usage.

8 DC ELECTRICAL CHARACTERIZATION

ABSOLUTE MAXIMUM RATINGS

Voltage Range on Any Lead with Respect to V_{SS} (except V_{DD})	-0.3V to +5.5V
Supply Voltage (V_{DD}) Range with Respect to V_{SS}	-0.3V to +3.63V
Operating Temperature Range for DS26324G	0°C to +70°C
Operating Temperature Range for DS26324GN	-40°C to +85°C
Storage Temperature	-55°C to +125°C
Soldering Temperature (reflow)	
Lead(Pb)-free	+260°C
Containing lead(Pb)	+240°C

This is a stress rating only and functional operation of the device at these or any other conditions above those indicated in the operation sections of this specification is not implied. Exposure to absolute maximum rating conditions for extended periods of time may affect reliability.

8.1 DC Pin Logic Levels

Table 8-1. Recommended DC Operating Conditions

($T_A = -40^\circ\text{C}$ to $+85^\circ\text{C}$ for DS26324GN.)

PARAMETER	SYMBOL	MIN	TYP	MAX	UNITS	NOTES
Logic 1	V_{IH}	2.0		5.5	V	
Logic 0	V_{IL}	-0.3		+0.8	V	
Supply	V_{DD}	3.135	3.3	3.465	V	

Table 8-2. Pin Capacitance

($T_A = +25^\circ\text{C}$)

PARAMETER	SYMBOL	MIN	TYP	MAX	UNITS	NOTES
Input Capacitance	C_{IN}		7		pF	
Output Capacitance	C_{OUT}		7		pF	

8.2 Supply Current and Output Voltage

Table 8-3. DC Characteristics

($V_{DD} = 3.135$ to 3.465V , $T_A = -40^\circ\text{C}$ to $+85^\circ\text{C}$.) (Note 1)

PARAMETER	SYMBOL	MIN	TYP	MAX	UNITS	NOTES
Supply Current at 3.465V	I_{DD}			1100	mA	2, 3
Supply Current at 3.3V			500			
Input Leakage	I_{IL}	-10.0		+10.0	μA	
Tri-State Output Leakage	I_{OL}	-10.0		+10.0	μA	
Output Voltage ($I_o = -4.0\text{mA}$)	V_{OH}	2.4			V	
Output Voltage ($I_o = +4.0\text{mA}$)	V_{OL}			0.4	V	

Note 1: Specifications to -40°C are guaranteed by design (GBD) and not production tested.

Note 2: $RCLK1-n = TCLK1-n = 1.544\text{MHz}$.

Note 3: Power dissipation with all ports active, TTIP and TRING driving a 25Ω load, for an all-ones data density.

9 AC TIMING CHARACTERISTICS

9.1 Line Interface Characteristics

Table 9-1. Transmitter Characteristics

PARAMETER		SYMBOL	MIN	TYP	MAX	UNITS	NOTES
Output Mark Amplitude	E1 75Ω	V_M	2.14	2.37	2.6	V	
	E1 120Ω		2.7	3.0	3.3		
	T1 100Ω		2.4	3.0	3.6		
	T1 110Ω		2.4	3.0	3.6		
Output Zero Amplitude		V_S	-0.3		+0.3	V	1
Transmit Amplitude Variation with Supply			-1		+1	%	
Transmit Path Delay	Single-Rail			8		UI	
	Dual-Rail			3			

Table 9-2. Receiver Characteristics

PARAMETER		SYMBOL	MIN	TYP	MAX	UNITS	NOTES
Cable Attenuation		Attn			12	dB	
Analog Loss-of-Signal Threshold				200		mV	1
Hysteresis Short-Haul Mode				100		mV	
Allowable Zeros Before Loss				192			2
				192			
				2048			
Allowable Ones Before Loss				24			3
				192			
				192			
Receive Path Delay	Single-Rail			8		UI	
	Dual-Rail			3			

Note 1: Measured at the RRING and RTIP pins.

Note 2: 192 zeros for T1 and T1.231 Specification Compliance; 192 zeros for E1 and G.775 Specification Compliance; 2048 zeros for ETS 300 233 compliance.

Note 3: 24 ones in 192-bit period for T1.231; 192 ones for G.775; 192 ones for ETS 300 233.

9.2 Parallel Host Interface Timing Characteristics

The following tables show the AC characteristics for the external bus interface.

Table 9-3. Intel Read Mode Characteristics

($V_{DD} = 3.3V \pm 5\%$, $T_J = -40^\circ C$ to $+125^\circ C$.) (Note 1) (See [Figure 9-1](#) and [Figure 9-2](#).)

SIGNAL NAME(S)	SYMBOL	DESCRIPTION	MIN	TYP	MAX	UNITS	NOTES
RDB	t1	Pulse width if not using RDYB	40			ns	2
CSB	t2	Setup time to RDB	0			ns	2
CSB	t3	Hold time from RDB	0			ns	2
AD[7:0]	t4	Setup time to ALE	2			ns	2
A[5:0]	t5	Hold time from RDB	0			ns	2
D[7:0], AD[7:0]	t6	Delay time RDB, CSB active			40	ns	2
D[7:0], AD[7:0]	t7	Deassert delay from RDB, CSB inactive	2		20	ns	2
RDYB	t8	Enable delay time from CSB active			20	ns	2
RDYB	t9	Disable delay time from the CSB inactive			15	ns	2
AD[7:0]	t10	Hold time from ALE	3			ns	2
ALE	t11	Pulse width	5			ns	2
D[7:0]	t12	Output delay from ALE Latched			40	ns	2
A[5:0]	t13	Setup time to RDB	10			ns	2
RDYB	t14	Delay time from RDB	0			ns	2
RDYB	t15	Active output delay time from RDB	10		35	ns	2

Note 1: The timing parameters in this table are guaranteed by design (GBD).

Note 2: The input/output timing reference level for all signals is $V_{DD}/2$.

Figure 9-1. Intel Nonmuxed Read Cycle

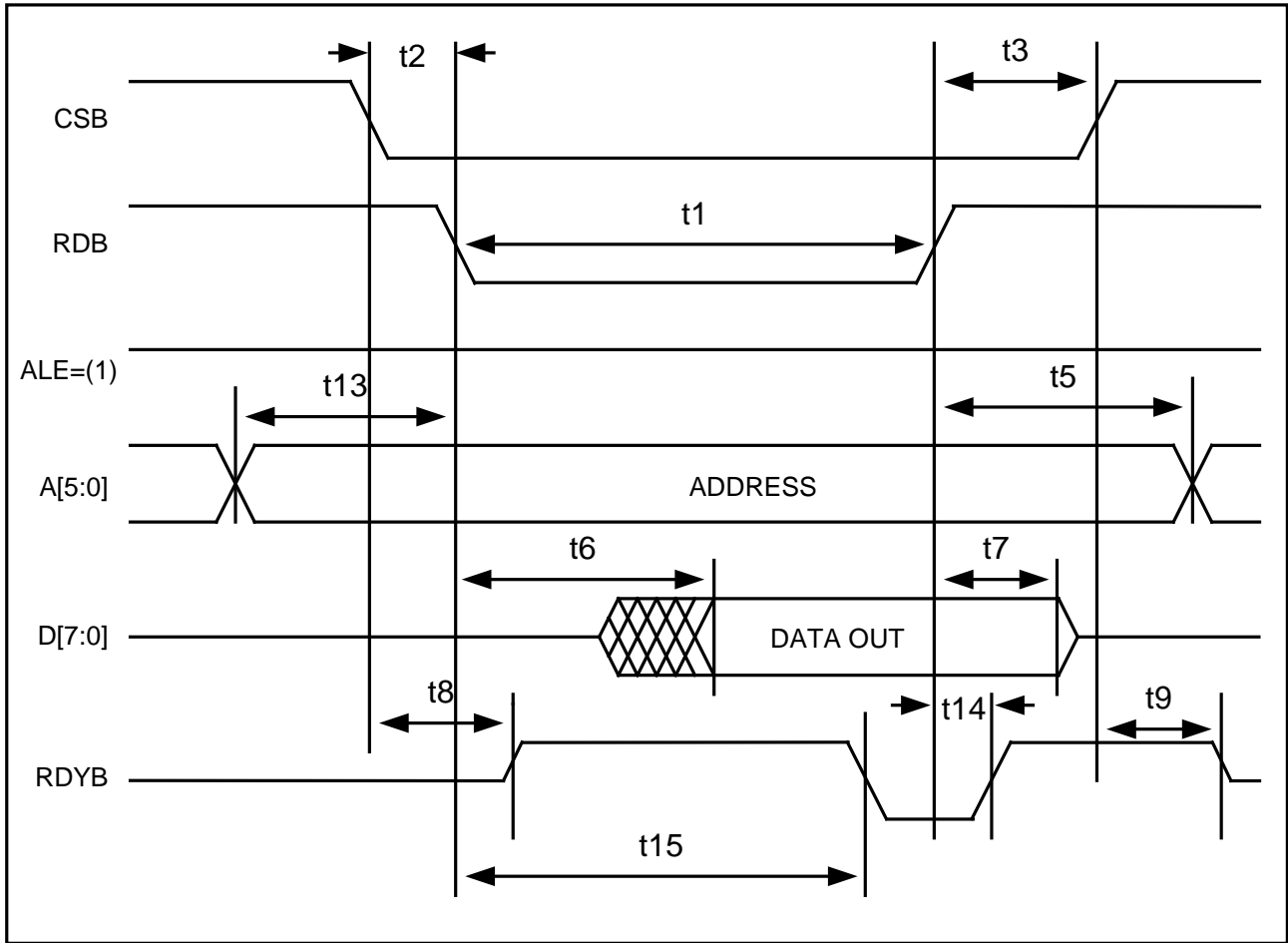

Figure 9-2. Intel Mux Read Cycle

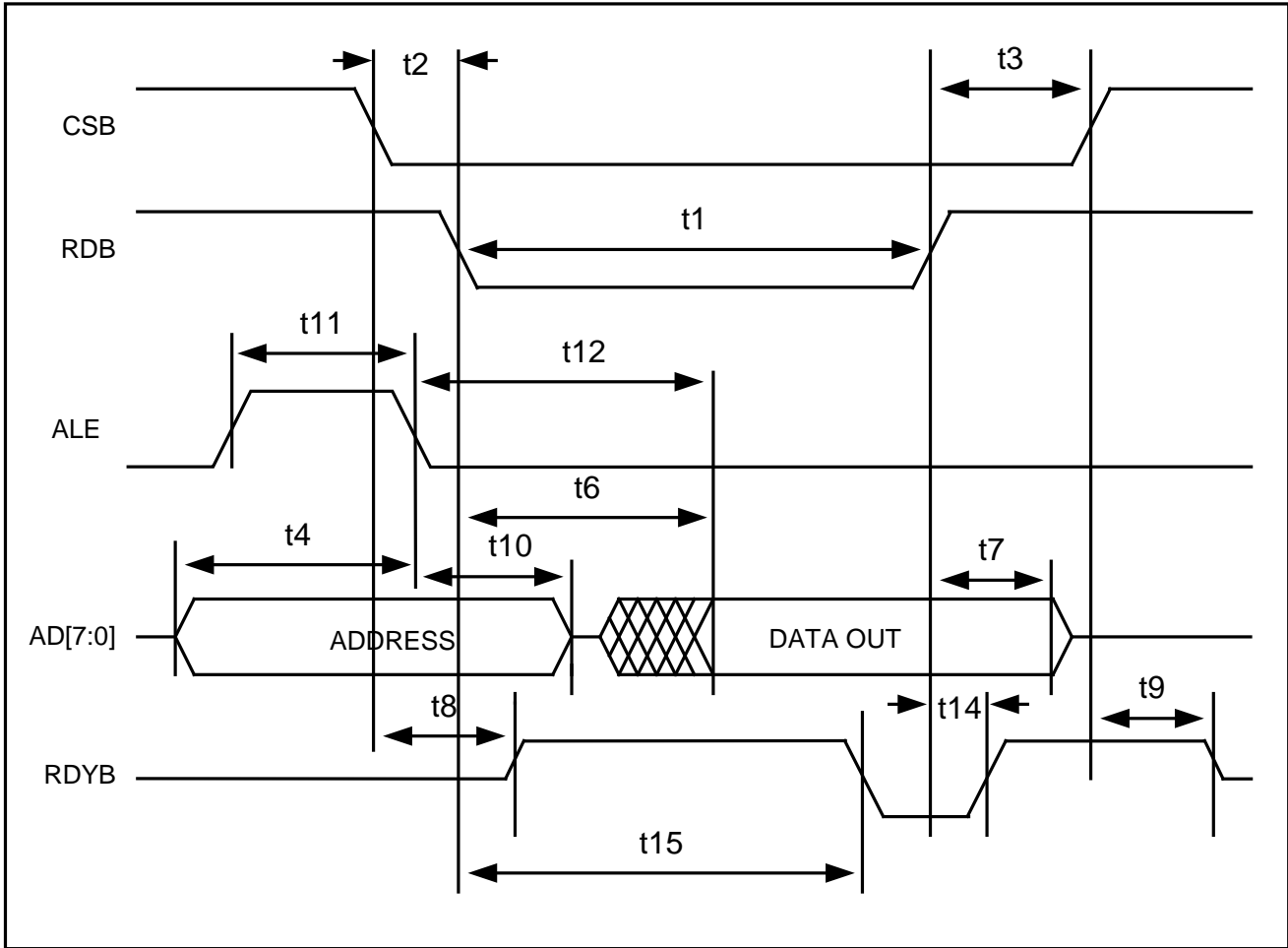

Table 9-4. Intel Write Cycle Characteristics(V_{DD} = 3.3V ±5%, T_J = -40°C to +125°C.) (Note 1) (See [Figure 9-3](#) and [Figure 9-4](#).)

SIGNAL NAME(S)	SYMBOL	DESCRIPTION	MIN	TYP	MAX	UNITS	NOTES
WRB	t1	Pulse width	40			ns	2
CSB	t2	Setup time to WRB	0			ns	2
CSB	t3	Hold time to WRB	0			ns	2
AD[7:0]	t4	Setup time to ALE	2			ns	2
A[5:0]	t5	Hold time from WRB	0			ns	2
D[7:0], AD[7:0]	t6	Input setup time to WRB	10			ns	2
D[7:0], AD[7:0]	t7	Input hold time to WRB	5			ns	2
RDYB	t8	Enable delay from CSB active			20	ns	2
RDYB	t9	Delay time from WRB active	10			ns	2
RDYB	t10	Delay time from WRB inactive	0			ns	2
RDYB	t11	Disable delay time from CSB inactive			15	ns	2
ALE	t12	Pulse width	5			ns	2
AD[7:0]	t13	Hold time from ALE inactive	3			ns	2
A[5:0]	t14	Valid address to WRB inactive	35			ns	2

Note 1: The timing parameters in this table are guaranteed by design (GBD).**Note 2:** The input/output timing reference level for all signals is V_{DD}/2.

Figure 9-3. Intel Nonmux Write Cycle

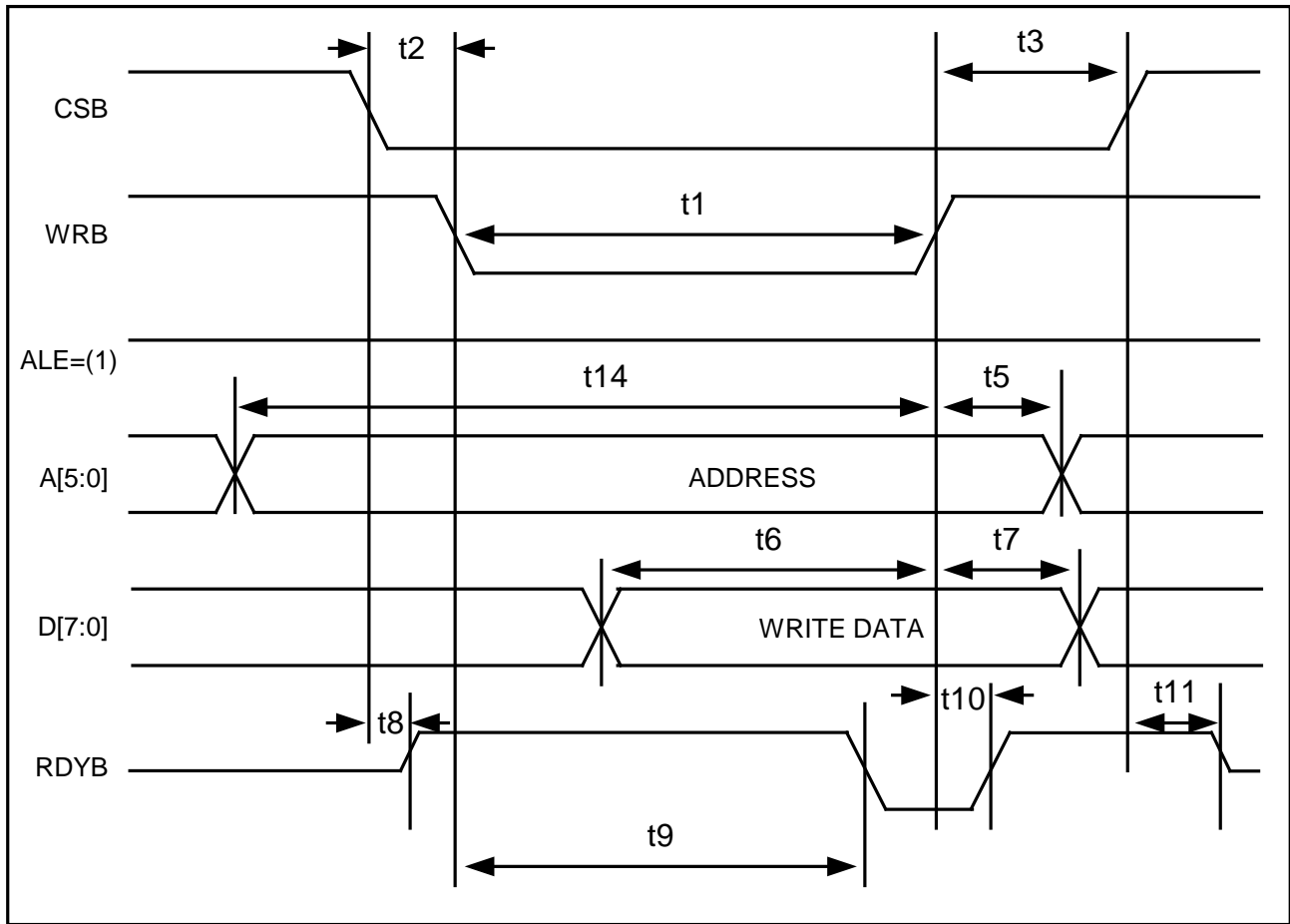

Figure 9-4. Intel Mux Write Cycle

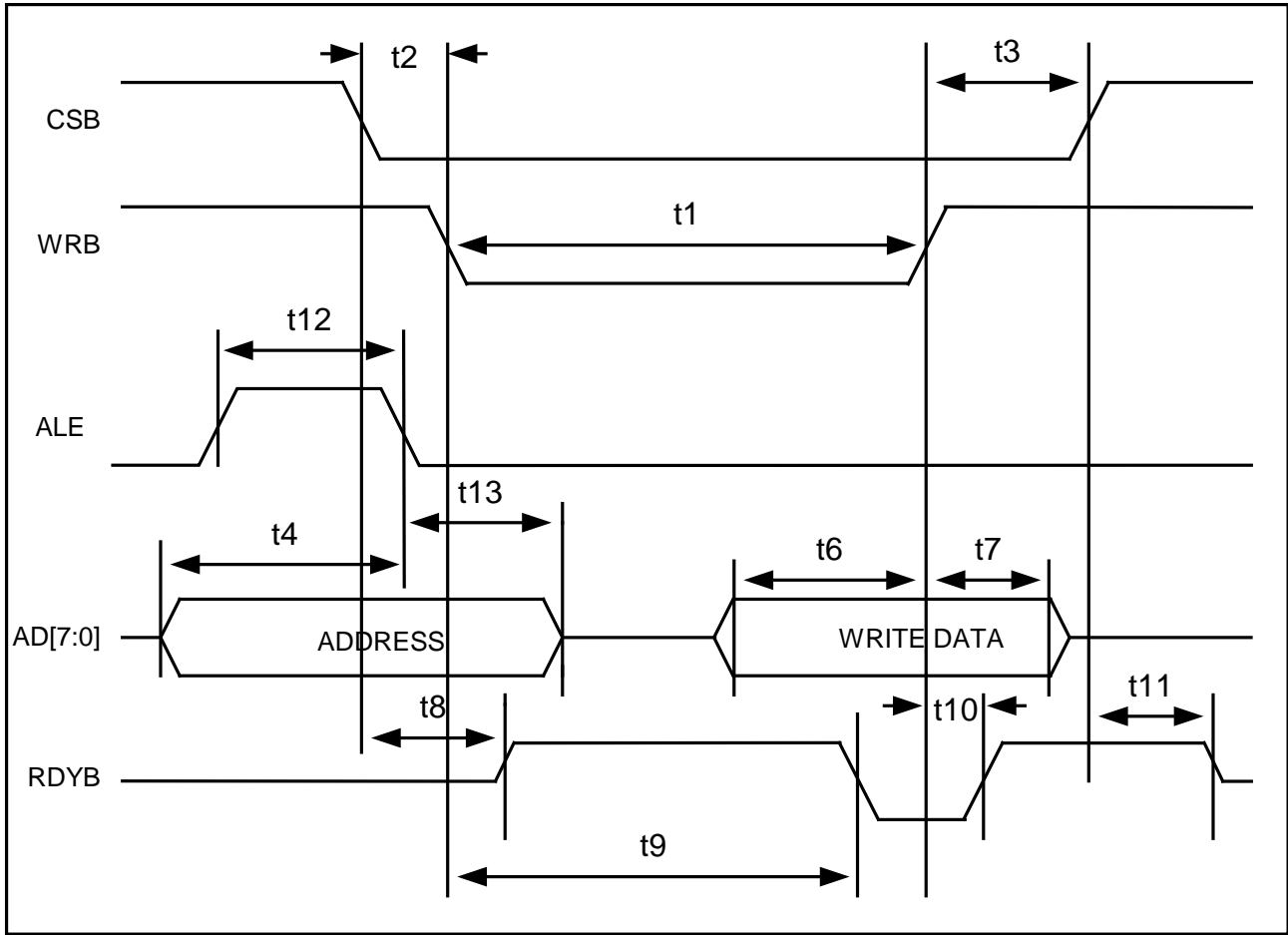

Table 9-5. Motorola Read Cycle Characteristics(V_{DD} = 3.3V ±5%, T_J = -40°C to +125°C.) (Note 1) (See [Figure 9-5](#) and [Figure 9-6](#).)

SIGNAL NAME(S)	SYMBOL	DESCRIPTION	MIN	TYP	MAX	UNITS	NOTES
DSB	t1	Pulse width	40			ns	2
CSB	t2	Setup time to DSB active	0			ns	2
CSB	t3	Hold time from DSB inactive	0			ns	2
RWB	t4	Setup time to DSB active	0			ns	2
RWB	t5	Hold time from DSB inactive	0			ns	2
AD[7:0]	t6	Setup time to ASB active	2			ns	2
AD[7:0]	t7	Hold time to ASB inactive	3			ns	2
AD[7:0], D[7:0]	t8	Output delay time from DSB active			40	ns	2
AD[7:0], D[7:0]	t10	Output valid delay time from DSB inactive	2		20	ns	2
ACKB	t11	Output delay time from CSB inactive			15	ns	2
ACKB	t12	Output delay time from DSB inactive	0			ns	2
ACKB	t13	Enable output delay time from DSB active			20	ns	2
ACKB	t14	Output delay time from DSB active	10		35	ns	2
A[5:0]	t15	Hold time from DSB inactive	0			ns	2
A[5:0]	t16	Setup time to DSB active	10			ns	2

Note 1: The timing parameters in this table are guaranteed by design (GBD).**Note 2:** The input/output timing reference level for all signals is V_{DD}/2.

Figure 9-5. Motorola Nonmux Read Cycle

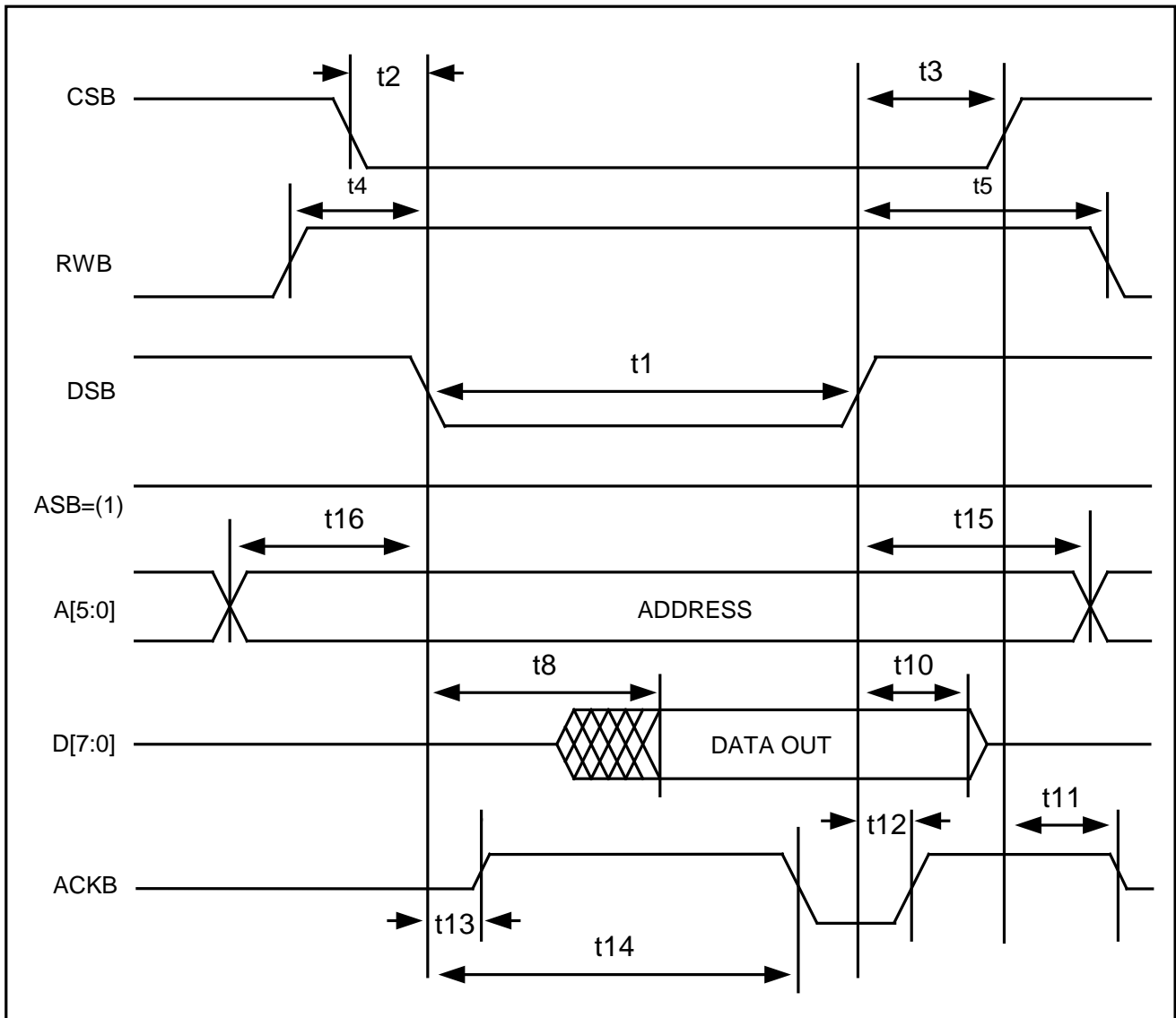

Figure 9-6. Motorola Mux Read Cycle

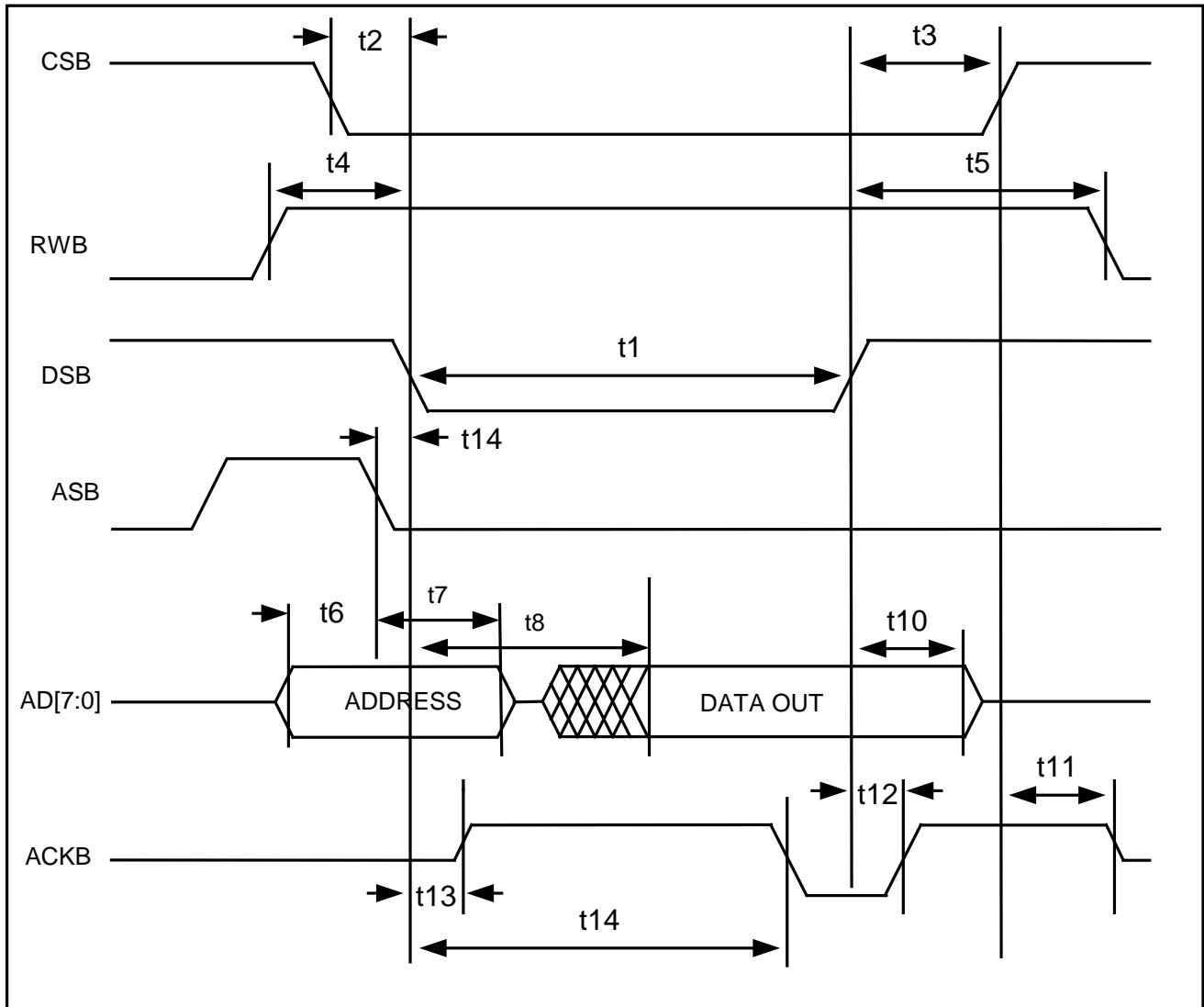

Table 9-6. Motorola Write Cycle Characteristics(V_{DD} = 3.3V ±5%, T_J = -40°C to +125°C.) (Note 1) (See [Figure 9-7](#) and [Figure 9-8](#).)

SIGNAL NAME(S)	SYMBOL	DESCRIPTION	MIN	TYP	MAX	UNITS	NOTES
DSB	t1	Pulse width	35			ns	2
CSB	t2	Setup time to DSB active	0			ns	2
CSB	t3	Hold time from DSB inactive	0			ns	2
RWB	t4	Setup time to DSB active	0			ns	2
RWB	t5	Hold time to DSB inactive	0			ns	2
AD[7:0]	t6	Setup time to ASB active	2			ns	2
AD[7:0]	t7	Hold time from ASB active	3			ns	2
AD[7:0], D[7:0]	t8	Setup time to DSB inactive	10			ns	2
AD[7:0], D[7:0]	t9	Hold time from DSB inactive	5			ns	2
A[5:0]	t10	Setup time to DSB active	10			ns	2
ACKB	t11	Output delay from CSB inactive			15	ns	2
ACKB	t12	Output delay from DSB inactive	0			ns	2
ACKB	t13	Output enable delay time from DSB active			20	ns	2
ACKB	t14	Output delay time from DSB active	10			ns	2
A[5:0]	t15	Hold time from DSB	0			ns	2

Note 1: The timing parameters in this table are guaranteed by design (GBD).**Note 2:** The input/output timing reference level for all signals is V_{DD}/2.

Figure 9-7. Motorola Nonmux Write Cycle

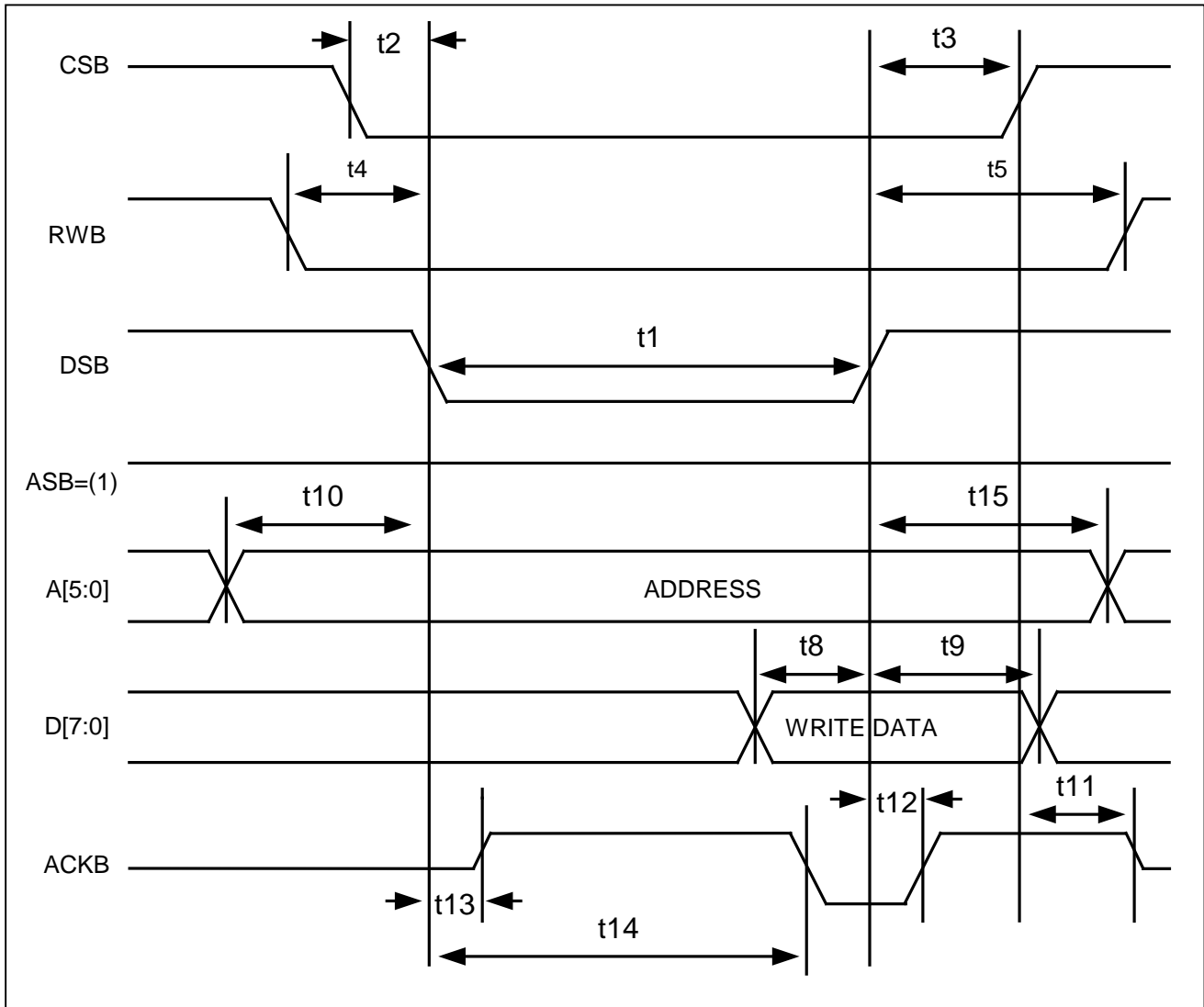
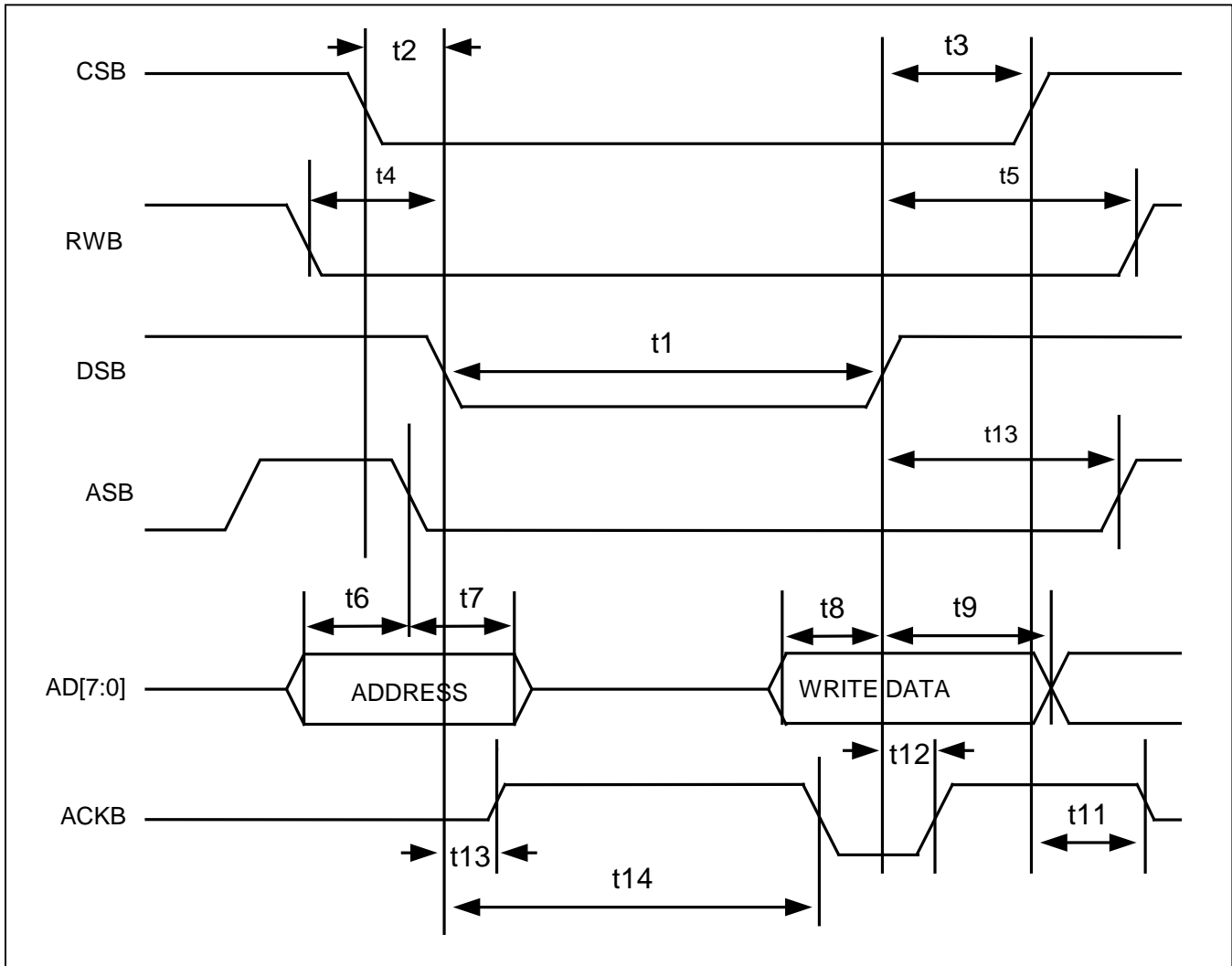

Figure 9-8. Motorola Mux Write Cycle



9.3 Serial Port

Table 9-7. Serial Port Timing Characteristics

(See [Figure 9-9](#), [Figure 9-10](#), and [Figure 9-11](#).)

PARAMETER	SYMBOL	MIN	TYP	MAX	UNITS	NOTES
SCLK High Time	t1	25			ns	
SCLK Low Time	t2	25			ns	
Active CSB to SCLK Setup Time	t3	50			ns	
Last SCLK to CSB Inactive Time	t4	50			ns	
CSB Idle Time	t5	50			ns	
SDI to SCLK Setup Time	t6	5			ns	
SCLK to SDI Hold Time	t7	5			ns	
SCLK Falling Edge to SDO High Impedance (CLKE = 0); CSB Rising to SDO High Impedance (CLKE = 1)	t8		100		ns	

Figure 9-9. Serial Bus Timing Write Operation

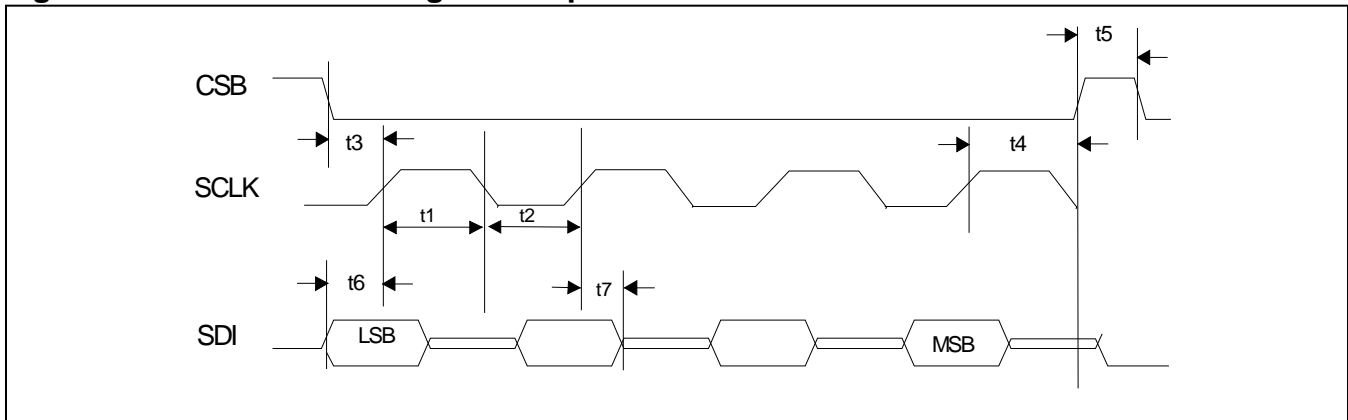

Figure 9-10. Serial Bus Timing Read Operation with CLKE = 0

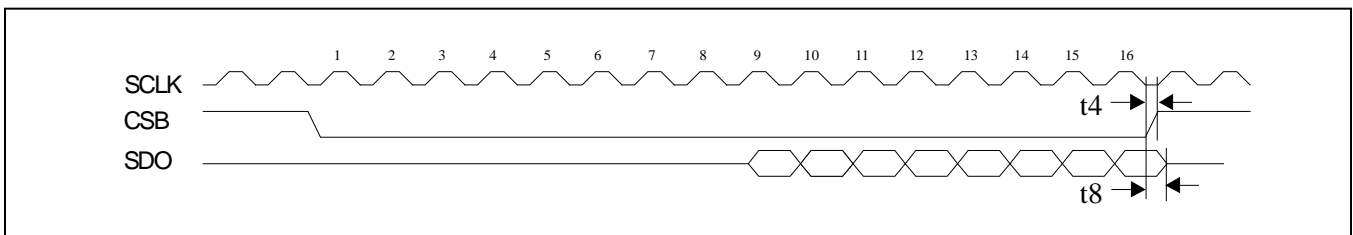
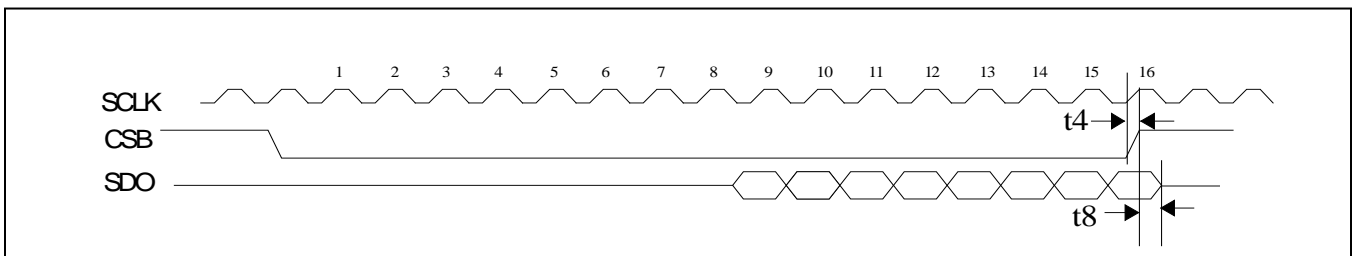

Figure 9-11. Serial Bus Timing Read Operation with CLKE = 1



9.4 System Timing

Table 9-8. Transmitter System Timing

(See [Figure 9-12.](#))

PARAMETER	SYMBOL	MIN	TYP	MAX	UNITS	NOTES
TPOS, TNEG Setup Time with Respect to TCLK Falling Edge	t1	40			ns	
TPOS, TNEG Hold Time with Respect to TCLK Falling Edge	t2	40			ns	
TCLK Pulse-Width High	t3	75			ns	
TCLK Pulse-Width Low	t4	75			ns	
TCLK Period	t5		488		ns	
			648			
TCLK Rise Time	t6			25	ns	
TCLK Fall Time	t7			25	ns	

Figure 9-12. Transmitter Systems Timing

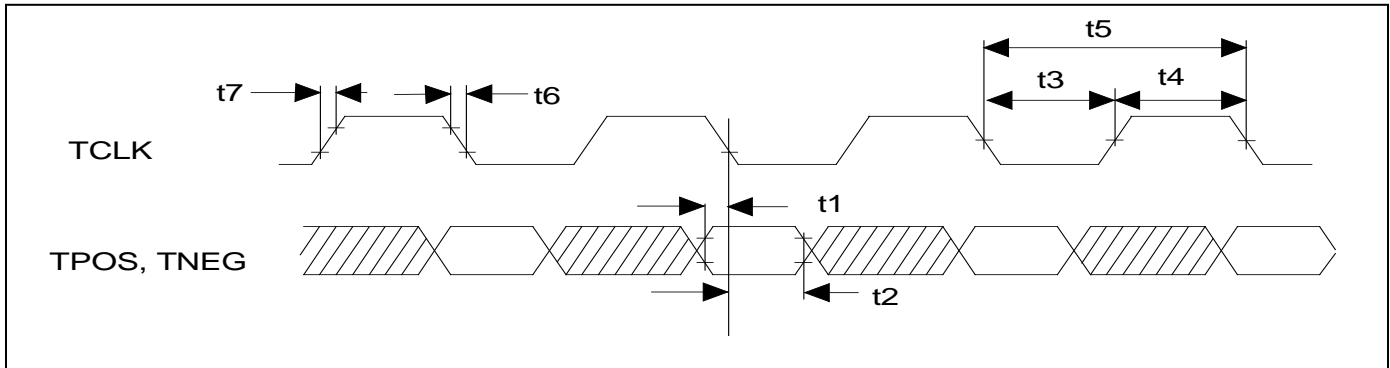
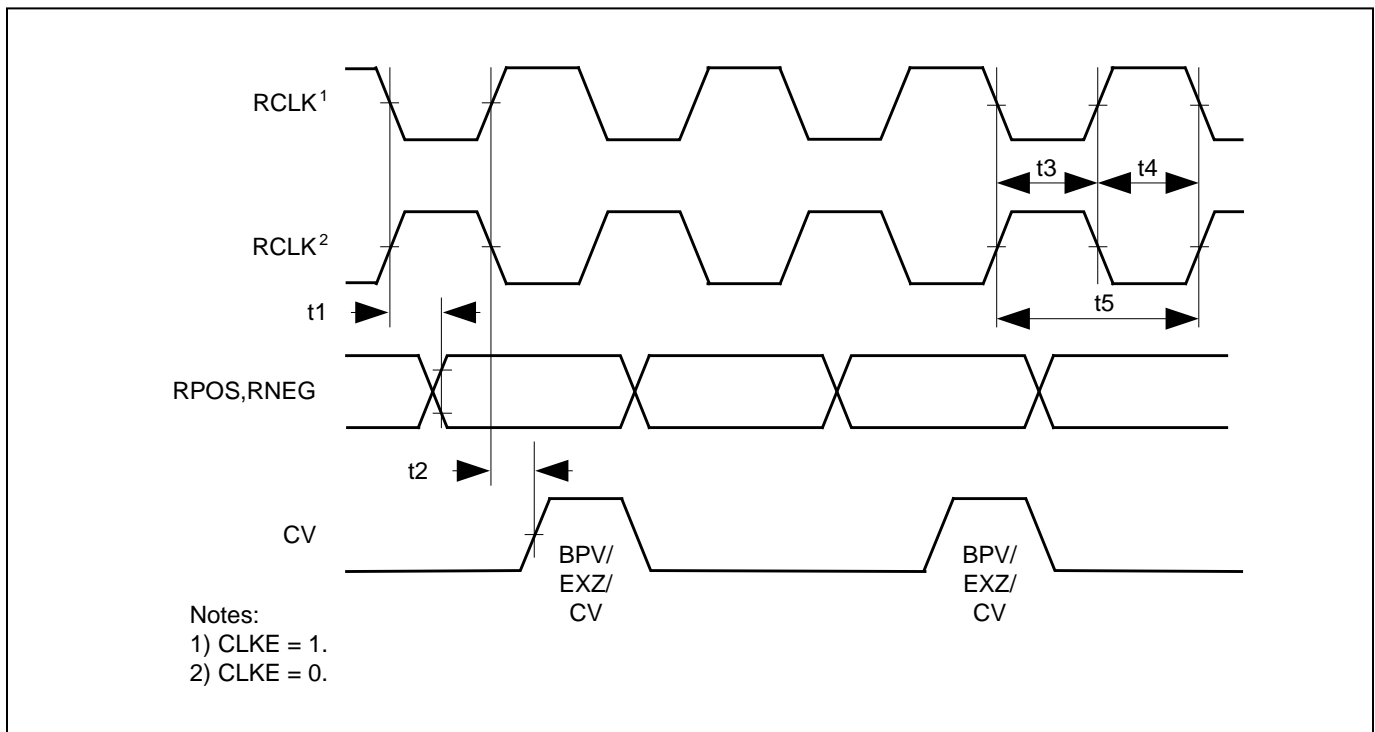

Table 9-9. Receiver System Timing

(See [Figure 9-13.](#))

PARAMETER	SYMBOL	MIN	TYP	MAX	UNITS	NOTES
Delay RCLK to RPOS, RNEG Valid	t1			50	ns	
Delay RCLK to CV Valid in Single-Rail Mode	t2			50	ns	
RCLK Pulse-Width High	t3	200			ns	
RCLK Pulse-Width Low	t4	200			ns	
RCLK Period	t5		488		ns	
			648			

Figure 9-13. Receiver Systems Timing



9.5 JTAG Timing

Table 9-10. JTAG Timing Characteristics

(See [Figure 9-14.](#))

PARAMETER	SYMBOL	MIN	TYP	MAX	UNITS	NOTES
TCK Period	t1	100			ns	
TMS and TDI Setup to TCK	t2	25			ns	
TMS and TDI Hold to TCK	t3	25			ns	
TCK to TDO Hold	t4			50	ns	

Figure 9-14. JTAG Timing

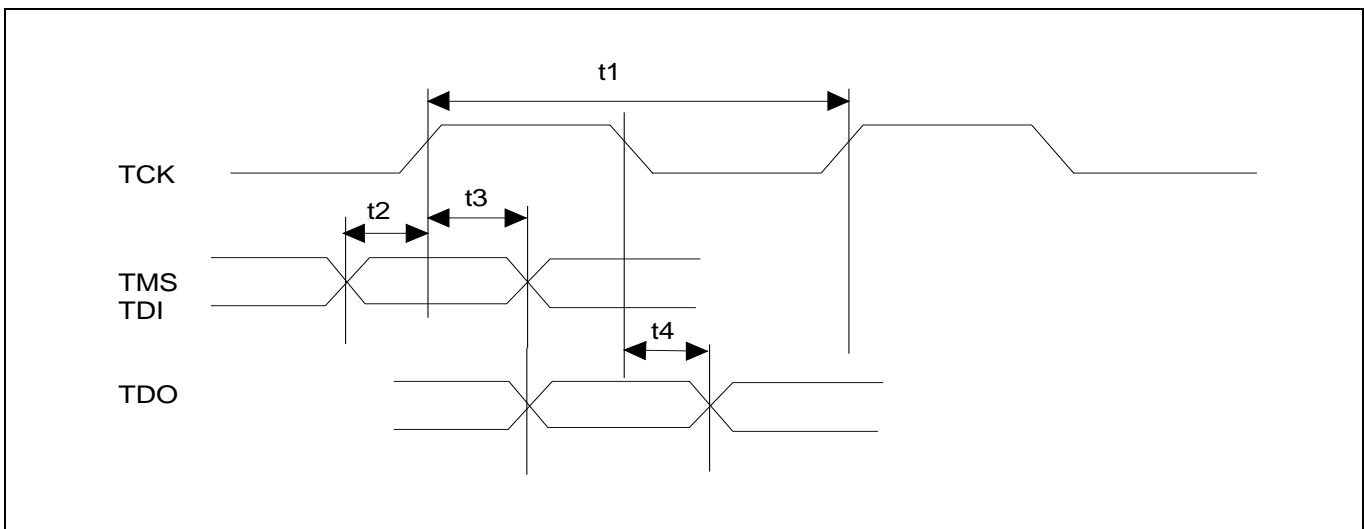

10 PIN CONFIGURATION

Figure 10-1. 256-Ball TE-CSBGA

	1	2	3	4	5	6	7	8	9	10	11	12	13	14	15	16
A	RTIP1	RRING1	MODESEL	RTIP16	VDDT16	TTIP16	TTIP15	VDDT15	RTIP15	VDDT14	TTIP14	TTIP13	VDDT13	RTIP14	TDO	RTIP13
B	AVDD	AVSS	MOTEL	RRING16	RSTB	TRING16	TRING15	LOS14	RRING15	LOS13	TRING14	TRING13	TMS	RRING14	TDI	RRING13
C	RTIP2	RRING2	TNEG1	A4	TNEG16	TNEG15	RNEG15	RPOS15	RNEG14	RPOS14	TCLK13	RPOS13	SDO/RDY/ACKB	TPOS12	AVSS	AVDD
D	VDDT1	LOS1	RCLK1	GNDT1	TPOS16	GNDT16	INTB	GNDT15	GNDT14	GNDT13	TCLK16	TCLK14	GNDT12	TCK	RRING12	RTIP12
E	TTIP1	TRING1	RNEG1	A5	RPOS16	RCLK16	TPOS14	RCLK13	RCLK14	RNEG13	LOS15	TCLK12	TNEG12	RPOS12	TRSTB	VDDT12
F	TTIP2	TRING2	RPOS2	RPOS1	TCLK1	TPOS1	TNEG14	RCLK15	TPOS13	LOS16	RNEG12	RCLK12	RNEG11	TCLK11	TRING12	TTIP12
G	VDDT2	LOS2	A2	TCLK2	RNEG2	RCLK2	TPOS2	TNEG13	TCLK3	TNEG4	TPOS11	RPOS11	RCLK11	SDI/WRB/DSB	TRING11	TTIP11
H	RTIP3	RRING3	A1	GNDT2	A3	TCLK4	AVDD	DVDD	DVSS	AVSS	TNEG11	MCLK	GNDT11	RDB/RWB	LOS12	VDDT11
J	VDDT3	LOS3	RNEG16	GNDT3	TNEG3	TPOS3	AVSS	DVSS	DVDD	AVDD	TPOS10	TNEG10	GNDT10	TNEG2	RRING11	RTIP11
K	TTIP3	TRING3	RCLK3	RNEG3	RCLK4	TPOS4	D3	RPOS5	TNEG8	RNEG8	TCLK9	TCLK10	RPOS10	RCLK10	LOS11	VDDT10
L	TTIP4	TRING4	RPOS3	RPOS4	D4	D0	RNEG5	TCLK6	TPOS5	TCLK7	TPOS9	TNEG9	RCLK9	RNEG10	TRING10	TTIP10
M	VDDT4	LOS4	RNEG4	D5	D1	TNEG5	TCLK5	RCLK6	RPOS6	RNEG6	TPOS8	RPOS8	RNEG9	RPOS9	TRING9	TTIP9
N	RTIP4	RRING4	D7	GNDT4	TPOS6	GNDT5	TCLK15	GNDT6	GNDT7	A0	GNDT8	TPOS15	GNDT9	SCLK/ALE/ASB	LOS10	VDDT9
P	AVDD	AVSS	D6	D2	RCLK5	TNEG6	TNEG7	RPOS7	TCLK8	RCLK7	RNEG7	TPOS7	RCLK8	CSB	RRING10	RTIP10
R	RRING5	LOS5	RRING6	LOS7	TRING5	TRING6	LOS8	RRING7	RESREF	TRING7	TRING8	OE	RRING8	LOS9	AVSS	AVDD
T	RTIP5	LOS6	RTIP6	VDDT5	TTIP5	TTIP6	VDDT6	RTIP7	VDDT7	TTIP7	TTIP8	VDDT8	RTIP8	CLKE/MUX	RRING9	RTIP9

11 PACKAGE INFORMATION

For the latest package outline information and land patterns (footprints), go to www.maxim-ic.com/packages. Note that a "+", "#", or "-" in the package code indicates RoHS status only. Package drawings may show a different suffix character, but the drawing pertains to the package regardless of RoHS status.

PACKAGE TYPE	PACKAGE CODE	OUTLINE NO.	LAND PATTERN NO.
265 TE-CSBGA	X256T+2	21-0315	90-0291

12 THERMAL INFORMATION

Table 12-1. Thermal Characteristics

PARAMETER	MIN	TYP	MAX	V (m/s)	NOTES
Ambient Temperature	-40°C		+85°C		1
Junction Temperature			+125°C		
Theta-JA (θ_{JA}) in Still Air Conduction		16.6°C/W		0	2
Theta-JC (θ_{JC}) Conduction		3.0°C/W			
Theta-JB (θ_{JB}) Conduction		7.5°C/W			
Theta-JA (θ_{JA}) in Forced Air		15.0°C/W		0.75	
Theta-JA (θ_{JA}) in Forced Air		14.6°C/W		1.25	
Theta-JA (θ_{JA}) in Forced Air		14.0°C/W		2.5	

Note 1: The package is mounted on a four-layer JEDEC standard test board.

Note 2: Theta-JA (θ_{JA}) is the junction-to-ambient thermal resistance, when the package is mounted on a four-layer JEDEC standard test board.

Table 12-2. Package Power Dissipation (for Thermal Considerations)

MODE	TYPICAL 50% 1s (Note 1)			TYPICAL 100% 1s (Note 2)			MAXIMUM 100% 1s (Note 3)		
	FULLY INTERNAL	PARTIALLY INTERNAL	EXTERNAL	FULLY INTERNAL	PARTIALLY INTERNAL	EXTERNAL	FULLY INTERNAL	PARTIALLY INTERNAL	EXTERNAL
E1-75Ω	1.64	1.43	1.31	2.56	2.15	1.90	2.82	2.36	1.98
E1-120Ω	1.49	1.19	1.19	2.23	1.62	1.62	2.54	1.69	1.69
T1-LBO0	1.87	1.52	1.47	2.96	2.26	2.14	3.56	2.51	2.23
T1-LBO1	1.92	1.57	1.51	3.03	2.32	2.20	3.63	2.57	2.30
T1-LBO2	1.95	1.60	1.55	3.06	2.35	2.29	3.66	2.60	2.39
T1-LBO3	1.99	1.63	1.58	3.12	2.41	2.29	3.72	2.67	2.39
T1-LBO4	2.02	1.67	1.61	3.16	2.46	2.34	3.77	2.72	2.44
J1-LBO0	1.84	1.49	1.47	2.90	2.20	2.14	3.44	2.36	2.23
J1-LBO1	1.89	1.54	1.51	2.96	2.26	2.20	3.51	2.42	2.30
J1-LBO2	1.92	1.57	1.55	2.99	2.29	2.29	3.54	2.45	2.39
J1-LBO3	1.95	1.60	1.58	3.05	2.35	2.29	3.60	2.52	2.39
J1-LBO4	1.99	1.63	1.61	3.10	2.39	2.34	3.65	2.57	2.44

Note 1: Typical voltage, transmitting/receiving 50% 1s in Watts.

Note 2: Typical voltage, transmitting/receiving 100% 1s in Watts.

Note 3: Maximum voltage, transmitting/receiving 100% 1s in Watts.

[Table 12-3](#) describes how much power to deduct per-channel from the total power dissipation values listed in [Table 12-2](#).

Table 12-3. Per-Channel Power-Down Savings (for Thermal Considerations)

MODE	TYPICAL 50% 1s (Note 1)			TYPICAL 100% 1s (Note 2)			MAXIMUM 100% 1s (Note 3)		
	FULLY INTERNAL	PARTIALLY INTERNAL	EXTERNAL	FULLY INTERNAL	PARTIALLY INTERNAL	EXTERNAL	FULLY INTERNAL	PARTIALLY INTERNAL	EXTERNAL
E1-75Ω	0.093	0.080	0.072	0.151	0.125	0.109	0.166	0.137	0.113
E1-120Ω	0.084	0.065	0.065	0.130	0.092	0.092	0.148	0.095	0.095
T1-LBO0	0.108	0.086	0.083	0.176	0.132	0.125	0.213	0.147	0.130
T1-LBO1	0.111	0.089	0.086	0.180	0.136	0.129	0.217	0.151	0.134
T1-LBO2	0.113	0.091	0.088	0.182	0.138	0.134	0.219	0.153	0.140
T1-LBO3	0.115	0.093	0.090	0.186	0.142	0.134	0.223	0.157	0.140
T1-LBO4	0.117	0.095	0.092	0.189	0.145	0.137	0.226	0.160	0.143
J1-LBO0	0.106	0.084	0.083	0.172	0.128	0.125	0.205	0.137	0.130
J1-LBO1	0.109	0.087	0.086	0.176	0.132	0.129	0.209	0.141	0.134
J1-LBO2	0.111	0.089	0.088	0.178	0.134	0.134	0.211	0.143	0.140
J1-LBO3	0.113	0.091	0.090	0.182	0.138	0.134	0.215	0.147	0.140
J1-LBO4	0.115	0.093	0.092	0.185	0.141	0.137	0.218	0.150	0.143

Note 1: Typical voltage, transmitting/receiving 50% 1s in Watts.

Note 2: Typical voltage, transmitting/receiving 100% 1s in Watts.

Note 3: Maximum voltage, transmitting/receiving 100% 1s in Watts.

$$T_A^{\circ}\text{C} + \theta_{JA} \times \text{Power Dissipation} \leq \text{Maximum Junction Temperature}$$

Where: T_A = Maximum Ambient Temperature

Example:

$$T_A = +70^{\circ}\text{C}$$

Mode = Typical 100% 1s E1-75Ω, Fully Internal Impedance Matching

Air Flow = 1.25m/s

$$70^{\circ}\text{C} + 14.6^{\circ}\text{C/W} \times 2.56\text{W} = 107^{\circ}\text{C}$$

This is below the maximum junction temperature and, therefore, this solution will support the thermal requirements.

13 DATA SHEET REVISION HISTORY

REVISION DATE	DESCRIPTION	PAGES CHANGED
070105	Initial release.	—
042007	Added descriptions of feature enhancements implemented in revision A2: <ol style="list-style-type: none"> 1) Programmable corner frequency for the jitter attenuator in E1 mode. 2) Fully internal impedance matching option for RTIP/RRING. 3) Option for system-side deployment of BERT. 4) Revised B8ZS/HDB3 sections for clarification of functions. 5) Added RESREF pin for receive termination calibration. See below for the detailed list of changes made to this data sheet revision.	
	See <i>Features</i> bullets, <i>Detailed Description</i> , and <i>Section 5.5.1</i> for mention of fully internal receive impedance matching.	1, 7, 27
	Added RESREF pin (R9).	11
	In OE pin description, changed GC.RTCTL to TST.RHPMC.	15
	Deleted R9 from DVSS.	16
	In <i>Section 5.4: Transmitter</i> , second paragraph, changed NRZ encoding to AMI encoding.	20
	Replaced <i>Figure 5-8</i> .	25
	In <i>Table 5-6</i> , updated Rt; updated <i>Section 5.4.3</i> and <i>Section 5.4.4</i> ; in <i>Section 5.4.5: Zero Suppression—B8ZS or HDB3</i> , removed “or Transmit Maintenance Register settings” from last sentence of first paragraph (no such register for this part).	26
	Changed <i>Section 5.4.8</i> name from <i>Drive Failure Monitor</i> to <i>Driver Fail Monitor</i> ; updated <i>Section 5.5</i> ; added new <i>Section 5.5.1: Receive Impedance Matching Calibration</i> .	27
	Added <i>Section 5.5.8: Receive Dual-Rail Mode</i> ; added new <i>Section 5.5.9: Receive Single-Rail Mode</i> ; updated <i>Table 5-11</i> .	30
	Updated <i>Section 5.8.2: Digital Loopback</i> .	33
	Added new paragraph to <i>Section 5.9: BERT</i> .	34
	Changed GMC to BGMC (<i>Table 6-1</i>) (see also page 53).	40
	In <i>Table 6-4</i> , deleted <i>Receive Bit Error Count Register 4</i> (does not exist for this part).	43
	In <i>Table 6-5</i> , changed bit names for LOSS (LIUs 1–16) to correctly match bit description on page 49; for TST, changed bits 7–5 from Reserved to JABWS1, JABWS0, and RHPMC (see also page 58).	44
	In <i>Table 6-6</i> , changed SRS bit to correctly say SRMS.	45
In <i>Table 6-7</i> , added missing address (27) to SHLHS for LIUs 9–16; changed bit 7 and bits 3–0 names for RSMM4 (LIUs 9–16) to correctly match bit description on page 74; changed “GISC” (3E) to “Not Used” for LIUs 9–16.	46	
In <i>Table 6-8</i> , changed BSR register bit 3 (PMS) to show it is read only (added underline), matching the bit description on page 88, as well as changed “RW” to “R” to correctly show all bits are read only; changed BSRL register bit 3 (PMSL) to show it is read only (added underline), matching the bit description on page 89, as well as changed “RL/W” to “R” to correctly show all bits are read only.	47	

REVISION DATE	DESCRIPTION	PAGES CHANGED
	Changed GMC to BGMC; changed bits 7, 6, and 5 from Reserved to BERTDIR, BMCKS, and BTCKS.	53
	In the GC register (LIUs 1–8), changed bit 7 from Reserved to RIMPMS and bit 2 from RTCTL to CRIMP (see also page 44, <i>Table 6-5</i>).	56
	In the GC register (LIUs 9–16), changed bit 7 from Reserved to RIMPMS and changed bit 2 from Reserved to CALEN (see also page 44, <i>Table 6-5</i>).	57
	For TST, changed bits 7, 6, and 5 from Reserved to JABWS1, JABWS0, and RHPMC.	58
	In the bit 7 (RIMPON) description, changed GC.RTCTL to TST.RHPMC; added note to bit description.	60
	Changed bit description for OE bits 7 to 0.	61
	For EZDE, corrected bit names for LIUs 1–16 from EXZDE[1:16] to EZDE[1:16]; changed bit description to say “Excessive zero detection is only relevant when HDB3 or B8ZS decoding is enabled.” For CVDEB, changed bit description to say “Code violation detection is only relevant when HDB3 decoding is enabled (LCS register).”	65
	Added note to bit 3 (RSMM1:RSSM4) description and updated descriptions for bits 6–4 and 2–0 (deleted “When” from each sentence for clarity).	71, 72, 73, 74
	Updated package drawing information.	117
	In <i>Table 12-1</i> , deleted “Power Dissipation in Package”; added new <i>Table 12-2. Package Power Dissipation (for Thermal Considerations)</i> and <i>Table 12-3. Per-Channel Power-Down Saving (for Thermal Considerations)</i> .	118
053107	Table 8-3: added “Note 1: Specifications to -40°C are guaranteed by design (GBD) and not production tested.”	97
	Table 9-3, 9-4, 9-5, and 9-6: added “Note 1: The timing parameters in this table are guaranteed by design (GBD).”	99, 102, 105, 108
012108	Changed the GC (2Fh) register bit 1 (JAPS) description.	57
3/11	Figure 10-1 in Section 10 PIN CONFIGURATION: Corrected cell R9. Changed from DVSS to RESREF.	115
	Pb-free ordering information added	1
	Table 4-1. PIN DESCRIPTION. TRSTB Function description changed. Replaced “floating” with “unconnected”	15
	Section 8 DC ELECTRICAL CHARACTERIZATION: Soldering information in ABSOLUTE MAXIMUM RATINGS table updated	97

Maxim cannot assume responsibility for use of any circuitry other than circuitry entirely embodied in a Maxim product. No circuit patent licenses are implied. Maxim reserves the right to change the circuitry and specifications without notice at any time.

Maxim Integrated Products, 120 San Gabriel Drive, Sunnyvale, CA 94086 408-737-7600

© 2011 Maxim Integrated Products

Maxim is a registered trademark of Maxim Integrated Products, Inc.