

Description

The YB1696 series are monolithic integrated circuits that provide all the active functions for a step-down DC/DC converter, capable of driving a 3A load without additional transistor component. Requiring a minimum number of external component, the board space can be saved easily. The external shutdown function can be controlled by TTL logic level and then come into standby mode. The internal compensation makes feedback control have good line and load regulation without external design. Regarding protected function, thermal shutdown is to prevent over temperature operating from damage, and current limit is against over current operating of the output switch. The YB1696 series operates at a switching frequency of 150KHz thus allowing smaller sized filter components than what would be needed with lower frequency switching regulators. Other features include a guaranteed $\pm 4\%$ tolerance on output voltage under specified input voltage and output load conditions, and $\pm 15\%$ on the oscillator frequency. The output version included fixed 5V and an adjustable type. The package is available in a standard 5-lead TO-263(S).

Features

- 5V and adjustable output versions
- Adjustable version output voltage range, 1.23V to 28V $\pm 4\%$ max over line and load condition
- Available in TO263-5L packages
- Voltage mode non-synchronous PWM control
- Thermal-shutdown and current-limit protection
- ON/OFF shutdown control input
- Input voltage range up to 32V
- Output load current: 3A
- 150 KHz fixed frequency internal oscillator
- Low power standby mode
- Built-in switching transistor on chip

Applications

- Simple High-efficiency step-down regulator
- Efficient preregulator for linear regulators
- On-card switching regulators
- Positive to negative converter
- Battery charger

Typical Application Circuit

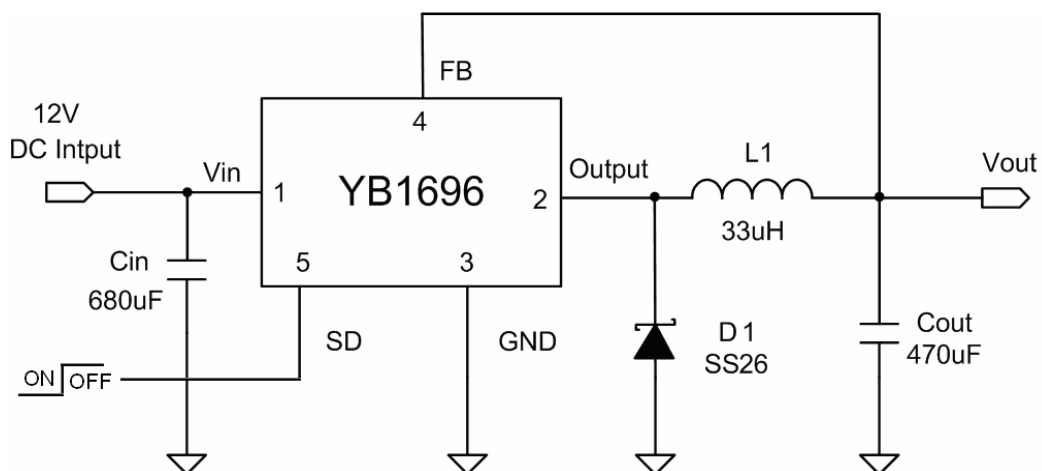

Pin Configuration

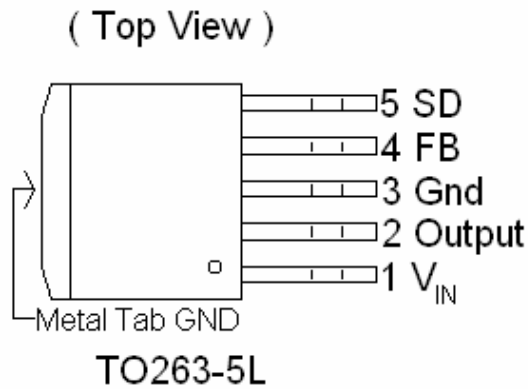

Pin Description

Table 1

Pin Name	Pin Function
VIN	Operating voltage input
OUTPUT	Switching output
GND	Ground
FB	Output voltage feedback control
SD	ON/OFF Shutdown

Ordering Information

YB1696-50 : For Fixed Output Voltage of 5.0V
YB1696-ADJ : For External Adjustable Version

Marking Information

YB1696-50 : For Fixed Output Voltage of 5.0V
YB1696-ADJ : For External Adjustable Version

Absolute Maximum Ratings

Symbol	Parameter	Rating	Unit
V_{CC}	Supply Voltage	+34	V
V_{SD}	ON/OFF Pin input voltage	-0.3 to +25	V
V_{FB}	Feedback Pin voltage	-0.3 to +25	V
V_{OUT}	Output voltage to Ground	-1	V
P_D	Power dissipation	Internally limited	W
T_{ST}	Storage temperature	-65 to +150	°C
T_{OP}	Operating temperature	-40 to +125	°C
V_{OP}	Operating voltage	+4.5 to +25	V

Electrical Characteristics

Unless otherwise specified, $V_{IN}=12V$ for 3.3V, 5V, adjustable version. $I_{LOAD}=0.3A$

Symbol	Parameter		Conditions	Min.	Typ.	Max.	Unit
I_B	Feedback current	bias	$V_{FB}=1.3V$ (Adjustable version only)		40	60	nA
						100	
F_{OSC}	oscillator frequency			127	150	173	Khz
				110		173	
V_{SAT}	saturation voltage		$I_{OUT}=3A$ no outside circuit $V_{FB}=0V$ force driver on		1.3	1.4	V
						1.5	
DC	Max. Duty Cycle(ON)		$V_{FB}=0V$ force driver on		100		%
	Min. Duty cycle(OFF)		$V_{FB}=12V$ force driver off			0	
I_{CL}	current limit		peak current no outside circuit $V_{FB}=0$ force driver on	3.6	4.5	5.5	A
						6.5	
I_L	Output = 0	Output leakage current	no outside circuit $V_{FB}=12$ force driver off $V_{IN}=32V$			200	uA
	Output = 1				2	60	mA
I_Q	Quiescent Current		$V_{FB}=12$ force driver off		5	10	mA
I_{STBY}	Standby Quiescent Current		ON/OFF pin=5V $V_{IN}=24V$		150	250	uA
						300	
V_{IL}	ON/OFF pin logic input threshold voltage		Low (regulator ON)	-	1.3	0.6	V
V_{IH}			High (regulator OFF)	2.0		-	
I_H	ON/OFF pin logic input current		$V_{LOGIC}=2.5V$ (OFF)		15	25	uA
I_L	ON/OFF pin input current		$V_{LOGIC}=0.5V$ (ON)		0.02	5	
Θ_{JC}	Thermal Resistance		Junction to case		3.5		$^{\circ}C/W$
Θ_{JA}	Thermal Resistance With copper area of approximately 3 in ²		Junction to ambient		23		$^{\circ}C/W$

	Symbol	Parameter	Conditions	Typ.	Limit	Unit
YB1696_ADJ	V_{FB}	Output Feedback	$5V \leq V_{IN} \leq 32V$ $0.2A \leq I_{LOAD} \leq 3A$ V_{OUT} programmed for 3V	1.23	1.193/1.18 1.267/1.28	V V_{MIN} V_{MAX}
	η	Efficiency	$V_{IN} = 12V, I_{LOAD}=3A$	73		%
YB1696_50	V_{OUT}	Output voltage	$8V \leq V_{IN} \leq 32V$ $0.2A \leq I_{LOAD} \leq 3A$	5	4.8/4.75 5.2/5.25	V V_{MIN} V_{MAX}
	η	Efficiency	$V_{IN} = 12V, I_{LOAD}=3A$	80		%

Typical Characteristics

Typical Performance Characteristics
Normalized Output Voltage

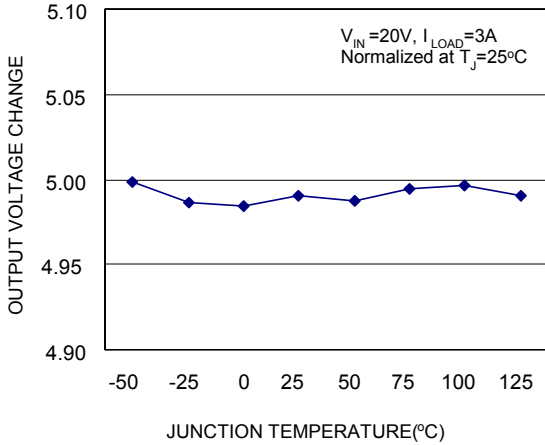

Efficiency

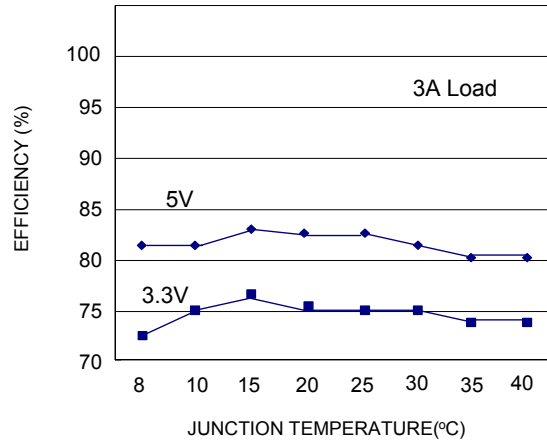

Switch Saturation Voltage

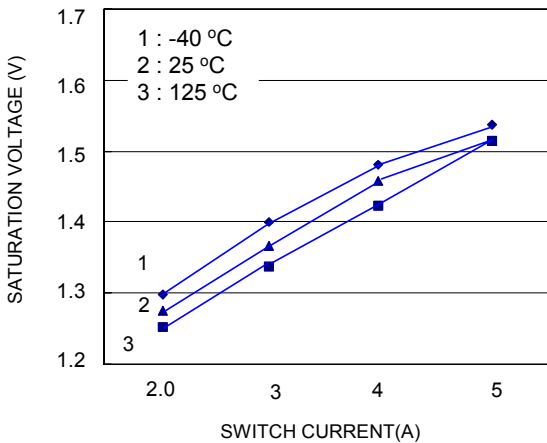

Switch Current Limit

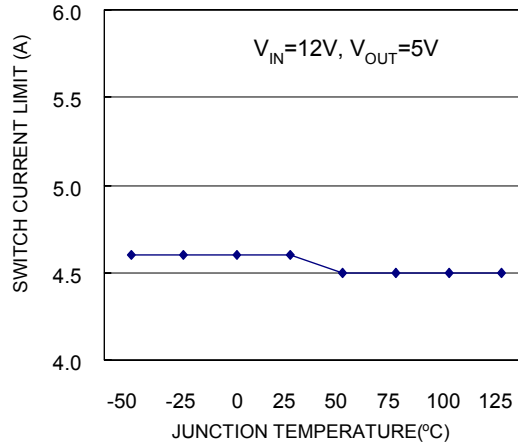

Operating Quiescent Current

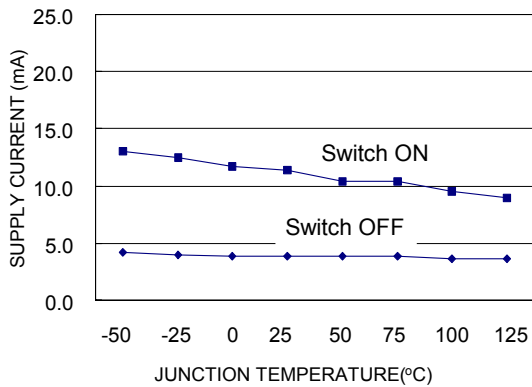

Shutdown Quiescent Current

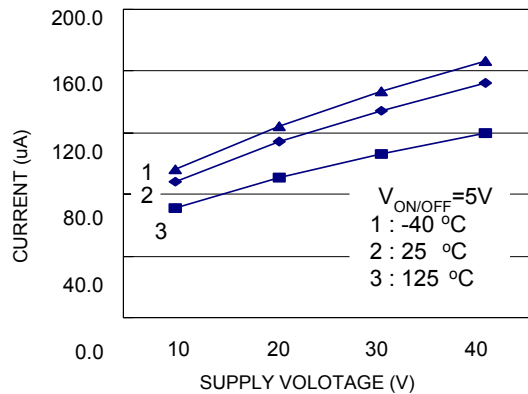

Minimum Operating Supply Voltage

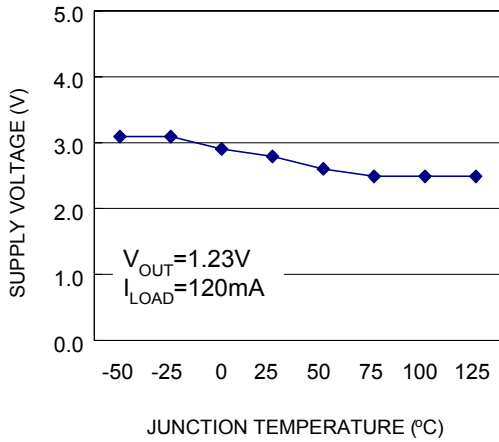

ON/OFF Threshold Voltage

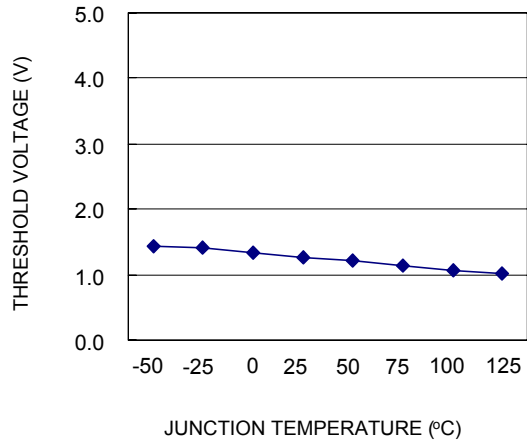

ON/OFF Pin Current (Sinking)

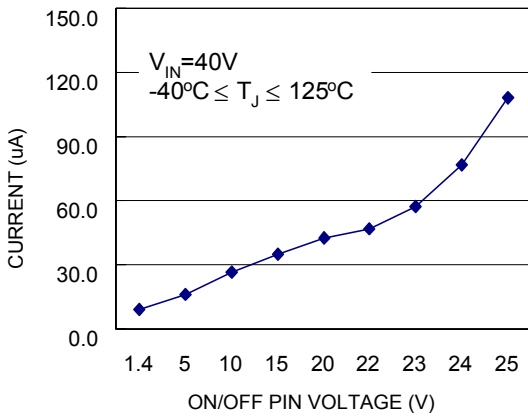

Switch Frequency

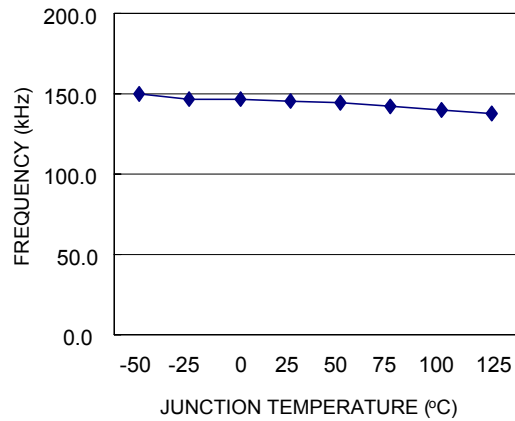

Feedback Pin Bias Current

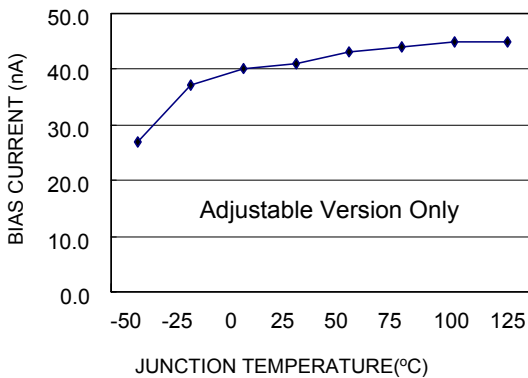

Functional Block Diagram

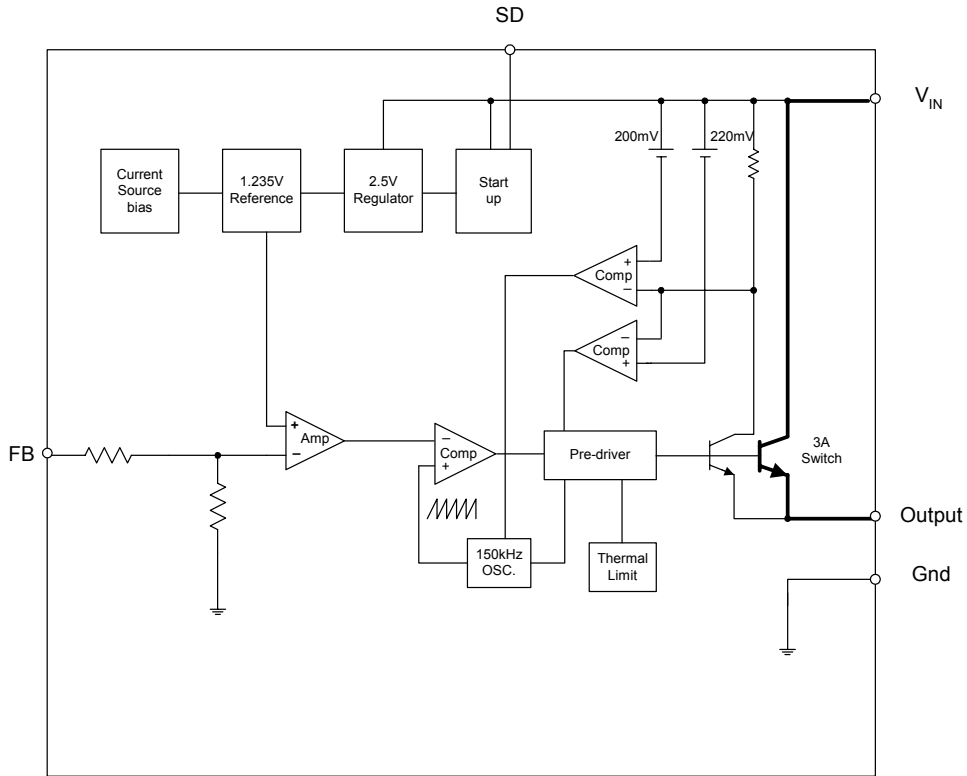

Typical Application Circuit

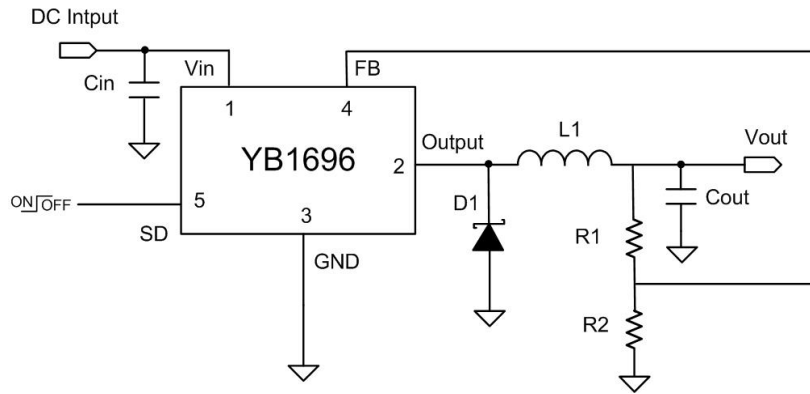

$$V_{out} = V_{FB} \times \left(1 + \frac{R1}{R2}\right)$$

$$V_{FB} = 1.23V$$

$$R2 = 0.47K \sim 2.6K$$

Resistor select for output voltage setting

Vout	R1	R2
5V	4.7K	1.5K
	5.6K	1.8K
3.3V	2.5K	1.5K
	3.0K	1.8K
2.5V	1.8K	1.8K
1.8V	0.82K	1.8K

Function Description

Pin Functions

+V_{IN}

This is the positive input supply for the IC switching regulator. A suitable input bypass capacitor must be present at this pin to minimize voltage transients and to supply the switching currents needed by the regulator.

Ground

Circuit ground.

Output

Internal switch. The voltage at this pin switches between $(+V_{IN} - V_{SAT})$ and approximately $-0.5V$, with a duty cycle of approximately V_{OUT} / V_{IN} . To minimize coupling to sensitive circuitry, the PC board copper area connected to this pin should be kept a minimum.

Feedback

Senses the regulated output voltage to complete the feedback loop.

$\overline{ON/OFF}$

Allows the switching regulator circuit to be shutdown using logic level signals thus dropping the total input supply current to approximately 150uA. Pulling this pin below a threshold voltage of approximately 1.3V turns the regulator on, and pulling this pin above 1.3V (up to a maximum of 25V) shuts the regulator down. If this shutdown feature is not needed, the $\overline{ON/OFF}$ pin can be wired to the ground pin or it can be left

open, in either case the regulator will be in the ON condition.

Thermal Considerations

The YB1696 is available in a 5-pin surface mount TO-263.

The TO-263 surface mount package tab is designed to be soldered to the copper on a printed circuit board. The copper and the board are the heat sink for this package and the other heat producing components, such as the catch diode and inductor. The PC board copper area that the package is soldered to should be at least 0.8 in², and ideally should have 2 or more square inches of 2 oz. Additional copper area improves the thermal characteristics, but with copper areas greater than approximately 6 in², only small improvements in heat dissipation are realized. If further thermal improvements are needed, double sided, multilayer PC board with large copper areas and/or airflow are recommended.

The YB1696 (TO-263 package) junction temperature rise above ambient temperature with a 2A load for various input and output voltages. This data was taken with the circuit operating as a buck switching regulator with all components mounted on a PC board to simulate the junction temperature under actual operating conditions. This curve can be

used for a quick check for the approximate junction temperature for various conditions, but be aware that there are many factors that can affect the junction temperature. When load currents higher than 3A are used, double sided or multilayer PC boards with large copper areas and/or airflow might be needed, especially for high ambient temperatures and high output voltages.

For the best thermal performance, wide copper traces and generous amounts of printed circuit board copper should be used in the board layout. (Once exception to this is the output (switch) pin, which should not have large areas of copper.) Large areas of copper provide the best transfer of heat (lower thermal resistance) to the surrounding air, and moving air lowers the thermal resistance even further.

Package thermal resistance and junction temperature rise numbers are all approximate, and there are many factors that will affect these numbers. Some of these factors include board size, shape, thickness, position, location, and even board temperature. Other factors are, trace width, total printed circuit copper area, copper thickness, single or double-sided, multilayer board and the amount of solder on the board. The effectiveness of the PC board to dissipate heat also depends on the size, quantity and spacing of other components on the board, as well as whether the surrounding air is still or

moving. Furthermore, some of these components such as the catch diode will add heat to the PC board and the heat can vary as the input voltage changes. For the inductor, depending on the physical size, type of core material and the DC resistance, it could either act as a heat sink taking heat away from the board, or it could add heat to the board.

Package Information

TO263-5L

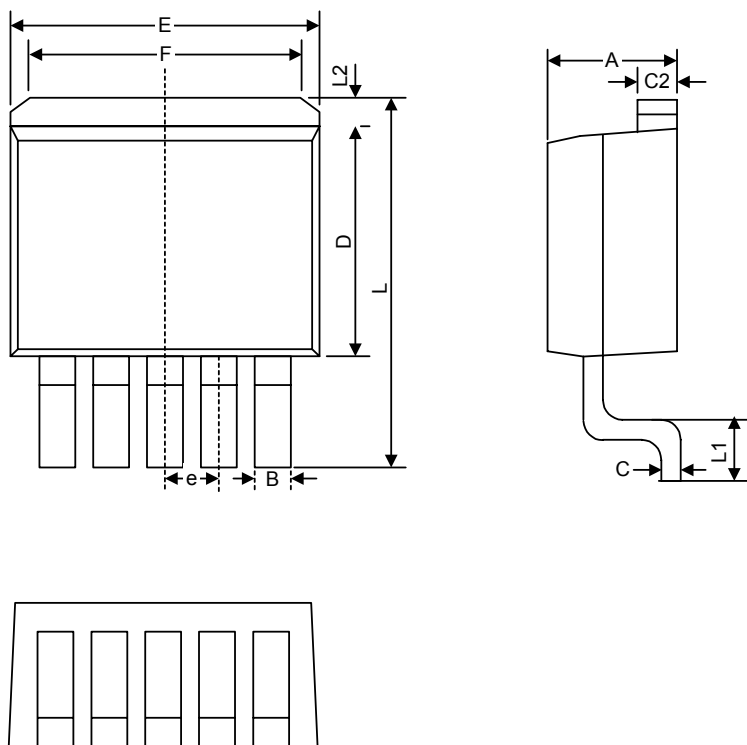

Symbol	Dimensions In Millimeters		Dimensions In Inches	
	Min.	Max.	Min.	Max.
A	4.38	4.78	0.172	0.188
B	0.72	0.92	0.028	0.036
C	0.36	0.41	0.014	0.016
C2	1.18	1.38	0.046	0.055
D	8.23	8.63	0.324	0.340
E	9.96	10.36	0.392	0.407
e	1.60	1.80	0.062	0.071
F	6.80	7.20	0.267	0.283
L	15.14	15.74	0.596	0.620
L1	2.28	2.79	0.089	0.110
L2	1.40	1.80	0.055	0.071