

SUBMINIATURE CONTROLLER FOR THERMOELECTRIC COOLERS

11/97

FEATURES:

- > PROPORTIONAL CONTROL
- > SMALL SIZE
- > DRIVE CURRENT TO +/- 2 AMPS
- > OPERATION TO 12 VOLTS
- > CONTROL ABOVE/BELOW AMBIENT

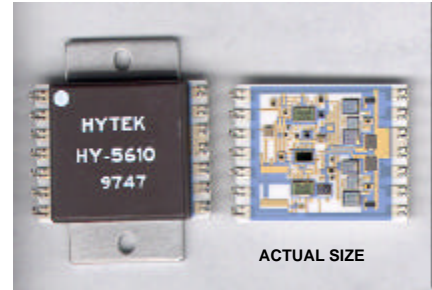

DESCRIPTION:

The HY-5610 is a subminiature proportional temperature controller for thermoelectric coolers (TEC). This device is intended for "heat or cool" fixed temperature applications where front panel controls and digital readouts are not required. The HY-5610 uses a thermistor bridge to precisely measure and regulate the temperature of a device affixed to a TEC. With proper heat sinking the power stage of this device will deliver up to +/- 2 Amperes of current to a TEC and will operate from a 5 to 12 Volt power supply.

MAXIMUM RATINGS:

Rating	Symbol	Value	Unit
Supply Voltage 1 (Voltage on Pin 8)	V _{DD}	+20	Volts DC
Supply Voltage 2 (Voltage on Pin 10)	V _S	+12	Volts DC
Current Sink (Heat and Cool Cycle)	I _S	2.5	Amperes
Maximum Power Dissipation	P _{MAX}	6	Watts
Operating Temperature (Case)	T _{MAX}	120	°C
Storage Temperature	T _{STG}	-65 to +150	°C

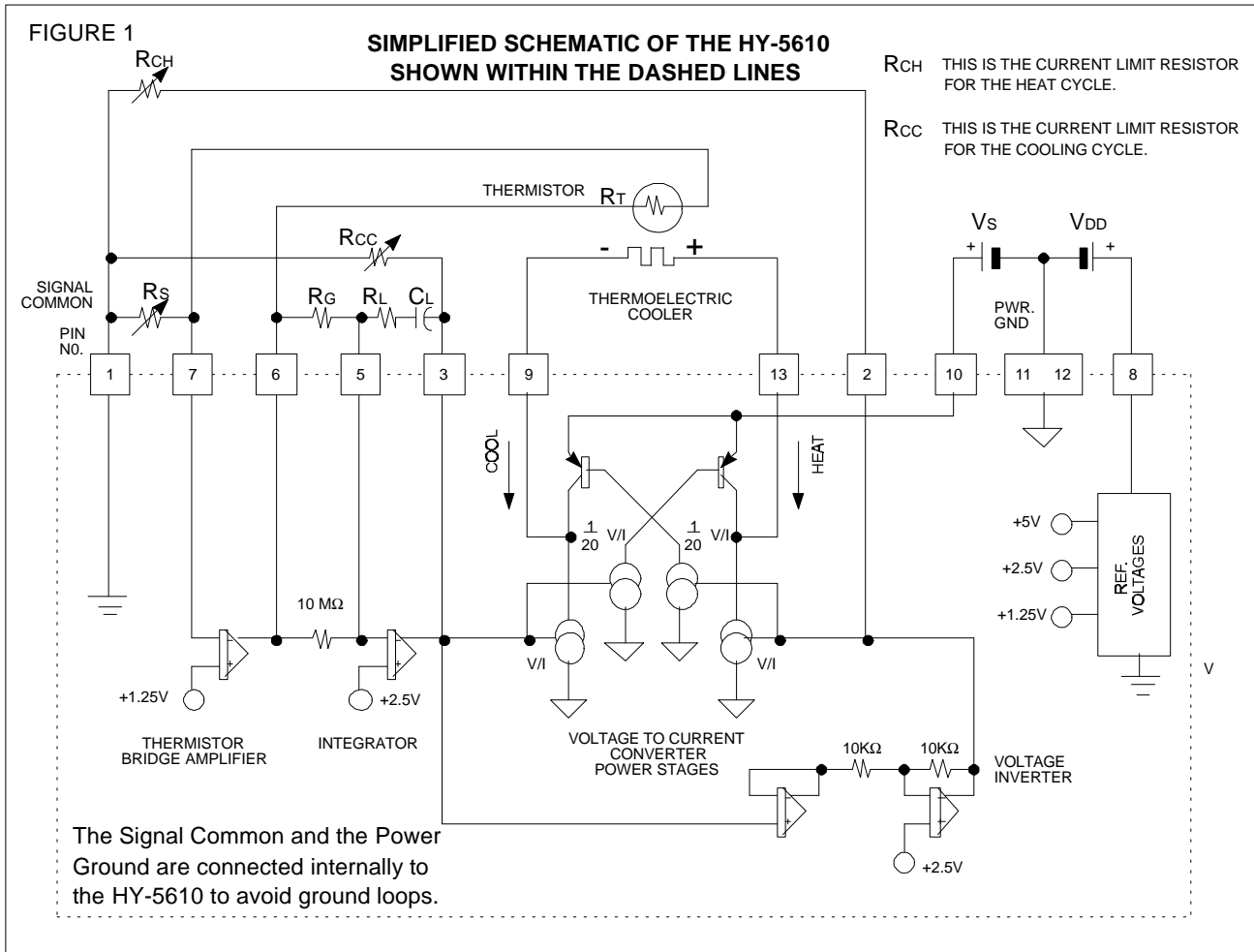

DESCRIPTION OF THE HY-5610 PIN OUTS

* Temperature Set Resistor R_s (Pin 1 to Pin 7)

The temperature set resistor for the HY-5610 controls the temperature at which the TEC will operate. When the circuit has stabilized, the resistance of the thermistor will be equal to that of the set resistor R_s . For example, if a Dale 10k Ω thermistor is used as the temperature sensing device, a set resistor of approximately 56k Ω will set an operating temperature of -10°C. A graph of R_s vs. set temperature is shown in figure 4 when using a Dale 1M1002 thermistor.

* Thermistor, R_T (Pin 6 to Pin 7)

The thermistor should be located in close proximity to the device being temperature controlled by the TEC. It should be in good thermal contact to avoid stability problems.

The HY-5610 has been designed for a negative temperature coefficient thermistor. A thermistor with a positive temperature coefficient can also be used if the position of the temperature set resistor and temperature sensing resistor are changed. The same result can also be achieved by reversing the leads of the TEC in which case R_{cc} & R_{ch} must be interchanged.

* Gain Set Resistor, R_G (Pin 5 to Pin 6)

The ratio of the gain set resistor R_G to R_L controls the response time of the servo loop. A ratio that is too large can cause slow response and a ratio that is too small can cause loop instability. In most applications R_G may not be needed since a 10M Ω resistor is internal to the HY-5610 and generally provides enough gain for good operation.

* Loop Stability Network, R_L and C_L (Pin 3 to Pin 5)

The RC time constant of these two components is a first approximation of the thermal time constant of the servo loop. The thermal time constant of the combination of the device being cooled, the thermistor, and the TEC can be approximated by applying constant power to the TEC and measuring the length of time it takes to reach 66% of its final temperature.

For example, if the thermal time constant was observed to be 5 seconds, then a 1 μ F capacitor and a 4.7M Ω could be chosen as the loop stabilizing components. Typical values for loop compensation components are shown in Table 1.

Note: The values of R_G , R_L , and C_L are generally selected by experiment. C_L should be a low leakage nonpolarized capacitor.

* Current Limit Resistors, R_{cc} & R_{ch} (Pin 1 to Pin 3, and Pin 1 to Pin 2)

These resistors limit the maximum current that the HY-5610 can supply to the TEC when in the cooling cycle and in the heating cycle. R_{cc} limits the maximum current for the cooling cycle and R_{ch} limits the maximum current in the heating cycle. This feature prevents damage to the TEC during turn-on. It is also often desirable to limit the maximum value of heating current as much as 30% less than the maximum cooling current. This is because TECs are much more efficient heating than cooling. Figure 5 shows the approximate values for R_{cc} & R_{ch} required to program a desired turn-on current. For example an R_{cc} value of 18K Ω will limit the maximum cooling current to 2 Amperes and an R_{ch} value of 13.5K Ω will limit the maximum heating current to 0.6 Amperes.

* V_{DD} (Pin 8 to Pins 11 & 12) +7 < V_{DD} < +20 Volts

This input supplies the voltage to the internal circuitry of the HY-5610. The maximum current drain at this terminal is 5mA.

* V_s (Pin 10 to Pins 11 & 12) +3 < V_s < +12 Volts

This input supplies the voltage to the HY-5610 power drive circuitry. The maximum current drain at this terminal should not exceed 2 Amperes.

* Thermoelectric Cooler, TEC (Pin 9 to Pin 13)

The cooling lead of the TEC should be connected to Pin 9 and the heating lead should be connected to Pin 13 of the HY-5610. If the temperature of the thermistor is greater than the set temperature at turn-on, maximum cooling current will flow into Pin 9 and out of Pin 13. Conversely, maximum heating current will flow into Pin 13 and out of Pin 9 if the temperature of the thermistor is less than the set temperature at turn-on. The maximum turn-on current is limited by R_{cc} and R_{ch} . Once the TEC reaches its set temperature, the current through the TEC will decrease to exactly the value required to maintain the correct set temperature.

HY-5610 CURRENT SOURCE CHARACTERISTICS

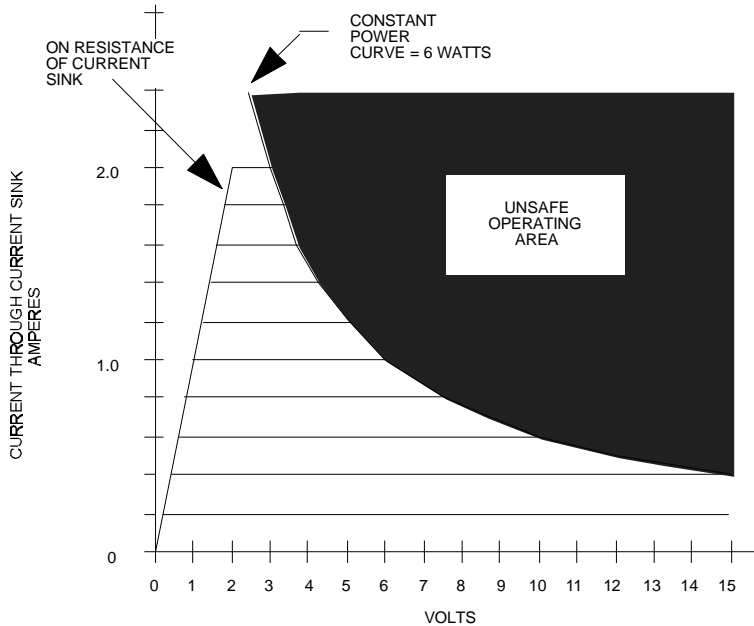

FIGURE 2
SUPPLY VOLTAGE (V_s)
PIN 10 TO GROUND (PIN 11 & 12)

Figure 2 illustrates the characteristics of the HY-5610 power drive section. It also illustrates the unsafe operating area where the power dissipated in the device exceeds the maximum 6 watt rating. This curve applies for both heating and cooling operation.

Note that the resistance of the power drive section is approximately one ohm when the HY-5610 is fully turned on.

DETERMINATION OF THE HY-5610 OPERATING POINTS USING LOAD LINES

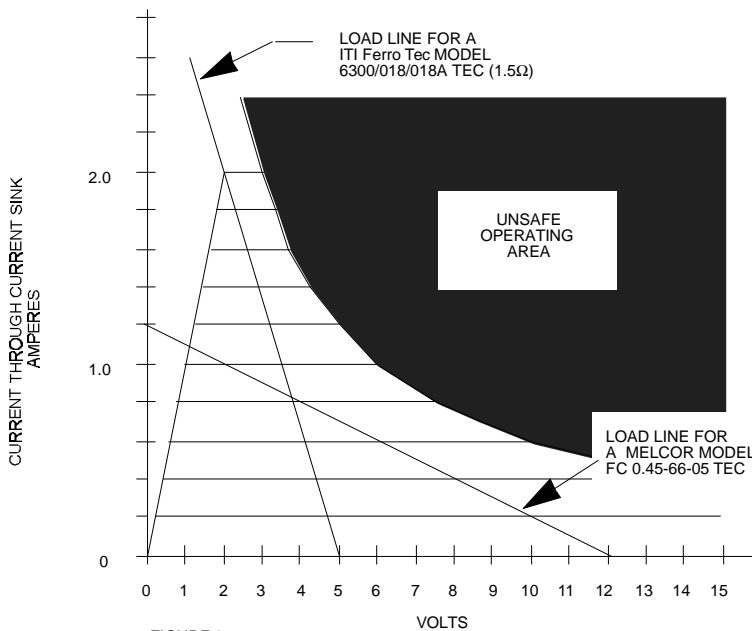

FIGURE 3
SUPPLY VOLTAGE (V_s)
PIN 10 TO GROUND (PIN 11 & 12)

Figure 3 illustrates the locus of operating current and voltage for two different TECs.

Example 1:

A supply voltage of 5 Volts was chosen for use with the ITI Ferro Tek Model 6300/018/018A TEC. This device is rated for a maximum current of 1.8 Amperes at a maximum allowable voltage of 2.7 Volts. This is a load resistance of approximately 1.5 ohms. The intersection of the 1.5 ohm load line and the HY-5610 current source characteristic's define the locus of operation voltage and current for both the HY-5610 and the TEC. In this application the current was limited to 1.8 Amperes when cooling and to 0.6 Amperes when heating by proper selection of R_{CC} & R_{CH}.

Example 2:

A supply voltage of 12 Volts was chosen for the Melcor FC 0.45-66-05 TEC. This device has a maximum rated voltage of 7.98 Volts at a current of 0.8 Amperes. A load line for this device is also shown on the plot. Once again maximum turn on current is set by proper selection of R_{CC} & R_{CH}.

Note that the power dissipated in the HY-5610 never exceeds the 6 Watt maximum power dissipation in both of these examples.

TEMPERATURE SET
RESISTOR R_s
VS
SET TEMPERATURE

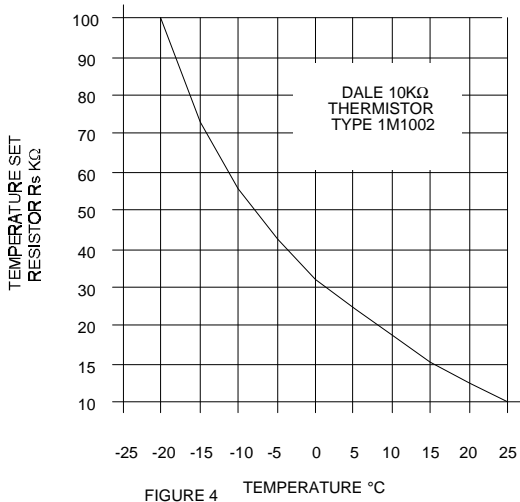

FIGURE 4 TEMPERATURE $^{\circ}$ C

APPROXIMATE VALUE OF CURRENT
LIMIT SET RESISTOR R_c
VS
MAXIMUM SINK CURRENT

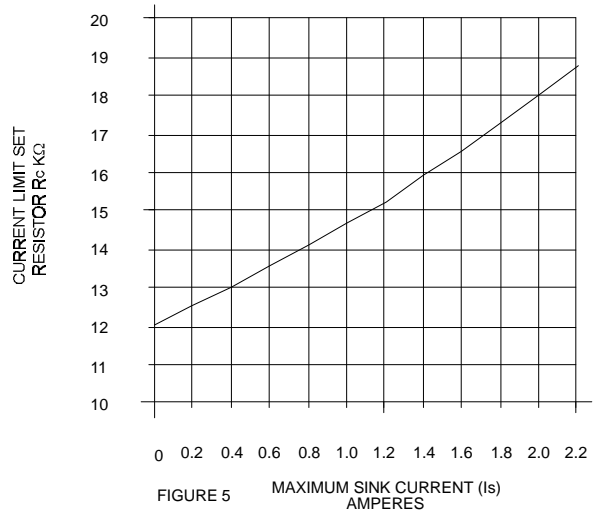
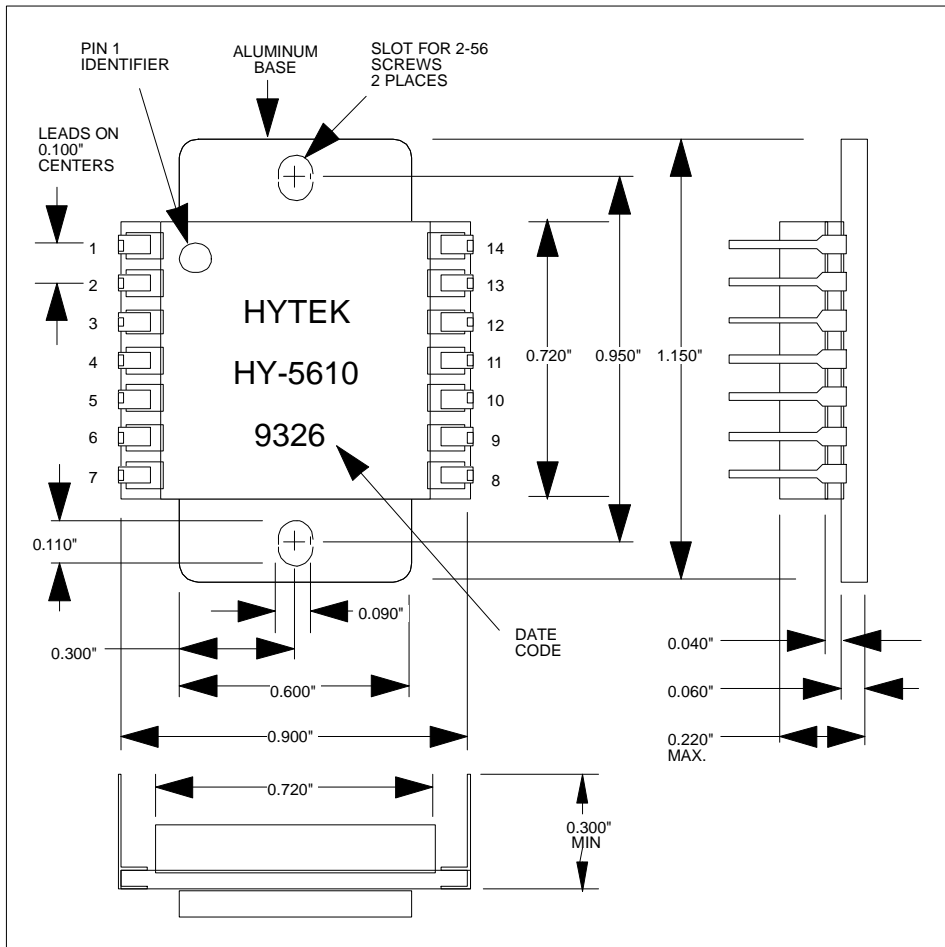

FIGURE 5 MAXIMUM SINK CURRENT (I_s) AMPERES

MECHANICAL DIMENSIONS



TYPICAL RESISTOR
AND CAPACITOR VALUES
FOR VARIOUS THERMAL
TIME CONSTANTS

THERMAL TIME CONSTANT T (SECONDS)			
	R_L	C_L	R_g
1	10 M Ω	0.1 μ F	100K Ω to 10M Ω ↓
2	20 M Ω	0.1 μ F	
3	3 M Ω	1.0 μ F	
5	4.7 M Ω	1.0 μ F	
10	10 M Ω	1.0 μ F	
15	15 M Ω	1.0 μ F	
20	20 M Ω	1.0 μ F	

TABLE 1

NOTES:

1. Make sure the heat sink to which the HY-5610 is mounted is flat and clean, otherwise the ceramic substrate may break.
2. Use a thermal compound such as Dow Corning 340 between the HY-5610 and the heat sink for good thermal conduction.
3. Note that the Pin 1 identifier is shown in a bottom view. From a top view, Pin numbers ascend in clockwise fashion.

Specifications Subject to Change Without Notice.