

LCD Module Technical Specification

First Edition
Sep 25, 2007

Final Revision
May 9, 2008

Type No. **T-51909GD019J-LW-ACN**

Customer : **OPTREX STANDARD**

Customer's Product No : -----

OPTREX CORPORATION

Approved: Minoru Akatsuka
QUALITY ASSURANCE DIVISION

Checked: Toshiyuki Okamoto
DESIGN 2T

Prepared: Takashi Yuchi
DESIGN 2T

Table of Contents

1. General Specifications.....	3
2. Electrical specifications	4
3. Optical Specifications	7
4. I/O Terminal.....	8
5. Test	10
6. Appearance Standards.....	11
7. Code System of Production Lot	16
8. Type Number.....	16
9. Precautions under operation	16
10. Precautions Relating Product Handling.....	17
11. Warranty.....	19

Revision History

Rev.	Date	Page	Comment
1	May 9, 2008	17~19	Revise of Precautions Relating Product Handling and Warranty.

1.General Specifications

Operating Temp.:	min. -20°C ~max. 70°C
Storage Temp. :	min. -30°C ~max. 80°C
Resolution :	176 x 3 [R.G.B] (W) x 220 (H) dots
Dot pitch :	0.171 (W) x 0.171 (H) dots
Pixel arrangement:	RGB-stripe
Color depth :	262,144 colors
Active Viewing Area :	30.096 (W) x 37.62 (H) mm
Outline dimensions :	40.657 (W) x 49.3* (H) x 5.5max** (D) mm * Without FPC ** Without Component Parts Area and Hook
Weight :	12.40max
LCD type :	TFT / Normally white-mode / Transmittance
Viewing angle :	6:00
TFT driver :	S1D19105 (Epson)
Interface :	80 system 8bit/9bit/16bit/18bit parallel interface 68 system 8bit/9bit/16bit/18bit parallel interface Serial interface 6bit/16bit/18bit RGB interface(for Movie)
Backlight :	3 chip LED backlight / White
Drawings :	Dimensional outline T-51909AC base
Lead free :	Our product corresponds to lead free. Lead free is defined as below: The solder used in the LCD module. Electrical components (Terminal section) used in the LCD module. Any lead used within the electrical component does not apply to our module definition of lead free.

2. Electrical specifications

2.1. Absolute Maximum Ratings

GND=0V

Parameter	Symbol	Conditions	Min.	Max.	Units
Supply Voltage	V _{DD1} -GND	-	-0.3	3.3	V
Supply for step-up Voltage	V _{DD2} -GND	-	-0.3	3.1	V
Input Voltage	V _{IN}	-	-0.3	V _{DD1} +0.3	V

2.2. DC Characteristics

Ta=25°C, GND=0V

Parameter	Symbol	Conditions	Min.	Typ.	Max.	Units
Supply Voltage	V _{DD1} -GND	-	1.7	1.8	1.9	V
Supply for step-up Voltage	V _{DD2} -GND	-	2.5	2.6	2.7	V
High Level Input Voltage	V _{IH}	-	0.8×V _{DD1}	-	V _{DD1}	V
Low Level Input Voltage	V _{IL}	-	GND	-	0.2×V _{DD}	V
High Level Output Voltage	V _{OH}	I _{OH} =0.06mA	V _{DD1} -0.3	-	V _{DD1}	V
Low Level Output Voltage	V _{OL}	I _{OL} =0.06mA	GND	-	V _{DD1} +0.3	V
Supply current for Logic	I _{DD1}	Still picture V _{DD1} - GND = 1.8V without backlight (Note 1,2)	-	2.3	3.5	μA
Supply current for Set-up	I _{DD2}	Still picture V _{DD2} - GND = 2.6V without backlight (Note 1,2)	-	7.5	11.3	mA

Note1: The driving conditions are to be described.

Note2: At all black pattern (262k color, Line inversion drive)

2.3.AC Characteristics

Shown in the S1D19105 and driver specifications.

2.4.Display screen

2.4.1.Correspondence of graphic memory data and display screen

The software setting is to be determined.

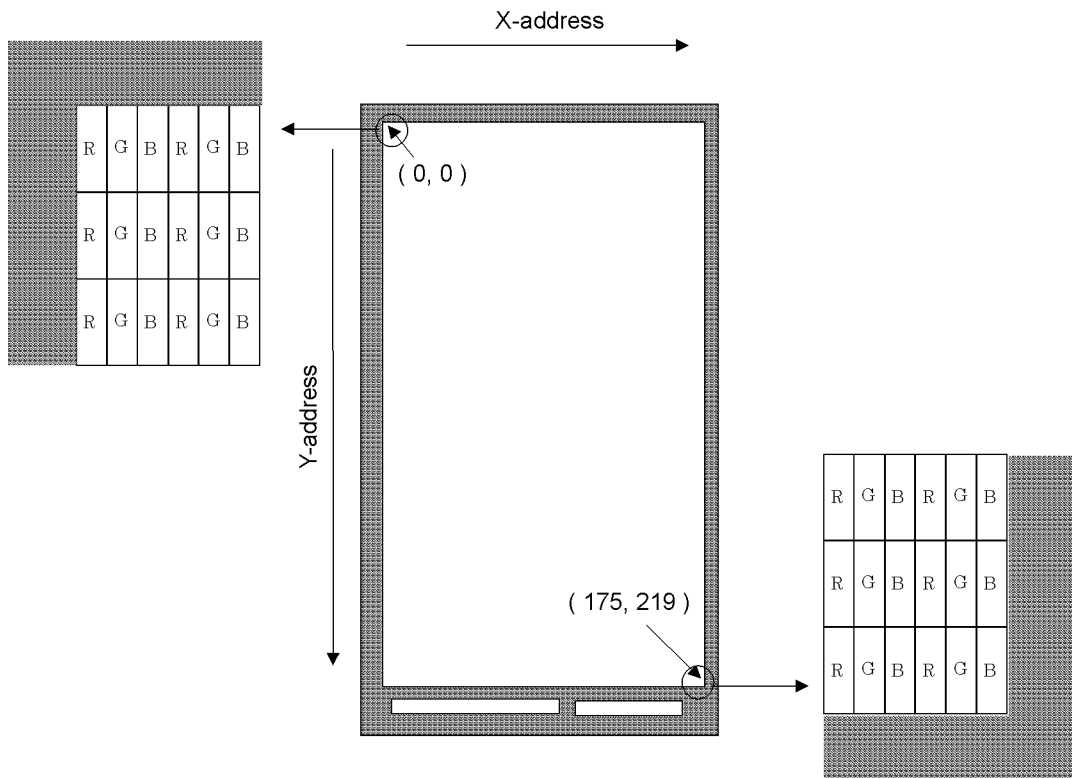

2.5. Lighting specification

2.5.1. Absolute Maximum Ratings

Ta=25°C

Parameter	Symbol	Conditions	Min.	Typ.	Max.	Units
Forward Current	I _F	-	-	-	30	mA
Reverse Voltage	V _R	-	-	-	15.0	V
LED Power Dissipation	P _D	-	-	-	360	mW

2.5.2. Operating characteristics

Ta=25°C

Parameter	Symbol	Conditions	Min.	Typ.	Max.	Units
Forward Voltage	V _F	I _F =13mA/chip	-	10.2	11.3	V
Luminance of Backlight Surface	L	I _F =13mA/chip	-	230	-	cd/m ²
Unevenness Luminance of Backlight Surface	L	I _F =13mA (for one chip) Note 2	-	70	-	%

Note 1: The measurement is done with backlight center.

Note 2: The measurement method is to be determined.

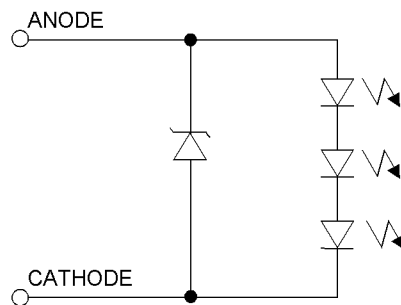

2.5.3. Color tone range (for LED chip only)

Tolerance : +/- 0.02

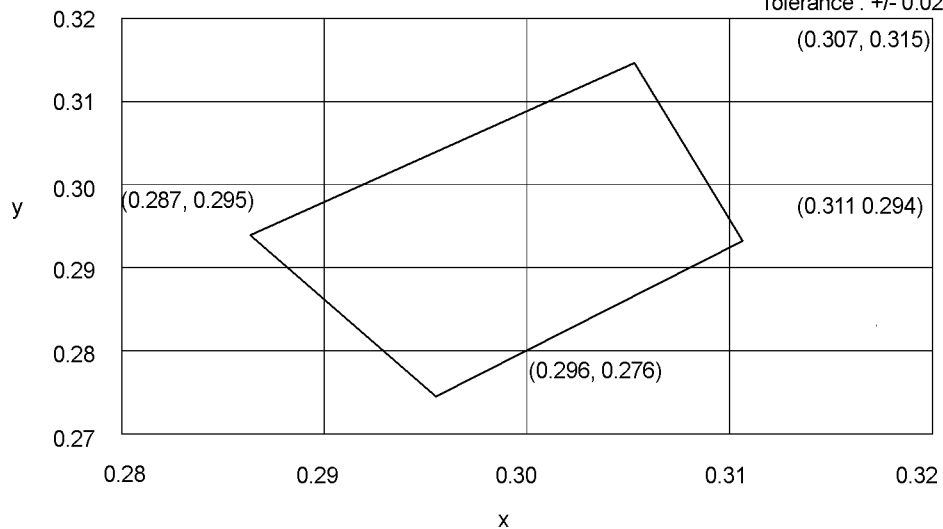

3. Optical Specifications

Item		Conditions	Min.	Typ.	Max.	Units	Remarks
Brightness			-	230	-	cd/m ²	Note 1
Transmittance			-	6.5	-	%	
Reflectance			-	2.1	-	%	Note 2
Viewing Angle			6:00				
Contrast ratio	Transmission	25°C	-	350	-		
Response time	Tr + Td	25°C	-	30	45	ms	
		-20°C	-	400	600	ms	
Color area	Transmission		-	70	-		Gamut
Color/ transmission	White	x	-	0.30	-		
		y	-	0.32	-		
	Red	x	-	0.60	-		
		y	-	0.35	-		
	Green	x	-	0.33	-		
		y	-	0.53	-		
	Blue	x	-	0.14	-		
		y	-	0.14	-		

Note 1: 3 LEDs back light, 13mA/chip

Note 2: Ring light measurement

(15deg. incident light, detected at normal direction)

The reflectance of white calibration plate is 100%.

4.I/O Terminal

4.1.Pin Assignment

No.	Symbol	Function
1	GND	Ground
2	V _{DD1} (1.8V)	Power Supply for Logic
3	V _{DD1} (1.8V)	Power Supply for Logic
4	V _{DD2} (2.6V)	Power Supply LCD step-up circuit
5	V _{DD2} (2.6V)	Power Supply LCD step-up circuit
6	SD	Serial Data Input / Outout
7	SCL	Serial Clock
8	ENABLE	RGB Interface Enable
9	DOTCLK	RGB Interface Dot Clock
10	HSYNC	Horizontal Synchronization
11	VSYNCl	Vertical Synchronization Input
12	VSYNCO	Vertical Synchronization Output
13	/CS	Chip Select Signal L : Active
14	RS	Register Select Signal H:RAM Write/Read, L:Instraction
15	/RD	80 family CPU L : Active
16	/WR	80 family CPU
17	D0	Data Bus
18	D1	Data Bus
19	D2	Data Bus
20	D3	Data Bus
21	D4	Data Bus
22	D5	Data Bus
23	D6	Data Bus
24	D7	Data Bus
25	D8	Data Bus
26	D9	Data Bus
27	D10	Data Bus
28	D11	Data Bus
29	D12	Data Bus
30	D13	Data Bus
31	D14	Data Bus
32	D15	Data Bus
33	D16	Data Bus
34	D17	Data Bus
35	/RES	Reset Signal L : Active
36	IF1	MPU Interface Switching Signal

37	IF2	MPU Interface Switching Signal
38	IF3	MPU Interface Switching Signal
39	C86	MPU Interface Switching Signal H:68-series L:80-series
40	LED A	LED Anode Terminal
41	LED A	LED Anode Terminal
42	LED K	LED Cathode Terminal
43	LED K	LED Cathode Terminal
44	GND	Power Supply (0V, GND)
45	GND	Power Supply (0V, GND)

IF3	IF2	IF1	Interface
Low	Low	Low	16-bit parallel
Low	Low	High	18-bit parallel
Low	High	Low	8-bit parallel
Low	High	High	9-bit parallel
High	High	High	9-bit serial

5. Test

No practical problems caused by any change on display and in operation under the following test condition.

Conditions: Unless otherwise specified, tests will be conducted under the following condition.

Temperature: $20 \pm 5^\circ\text{C}$

Humidity : $65 \pm 5\% \text{RH}$

Tests will be not conducted under operating state unless specified.

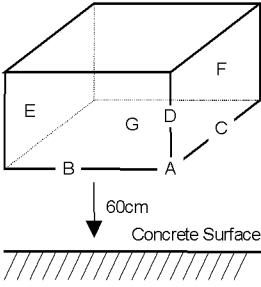
No.	Parameter	Conditions	Notes
1	High Temperature Operating	70°C , 96hrs (operation state)	1
2	Low Temperature Operating	-20°C , 96hrs (operation state)	2
3	High Temperature Storage	80°C , 96hrs	3
4	Low Temperature Storage	-30°C , 96hrs	2,3
5	Damp Proof Test	40°C , 90%RH, 96hrs	2,3
6	Vibration Test	Total fixed amplitude: 1.5mm Vibration frequency: 10–55Hz (60 sec. sweep) Time duration: 15 minutes for each x, y, z direction	3
7	Shock Test	To be measured after dropping from 60cm height to the concrete surface with shipping package. 	4

Note 1: It should be checked at the actual driving condition under the high temperature.

Note 2: No dew condensation is to be observed.

Note 3: The functional test shall be conducted after 4 hours storage at the room temperature and humidity after removed from the test chamber.

Note 4: Shock test will be conducted to the product itself without any actual set.

6.Appearance Standards

6.1.Inspection

The distance between the eyes and the sample shall be more than 30cm.
All directions for inspecting the sample should be within 45°against perpendicular line.

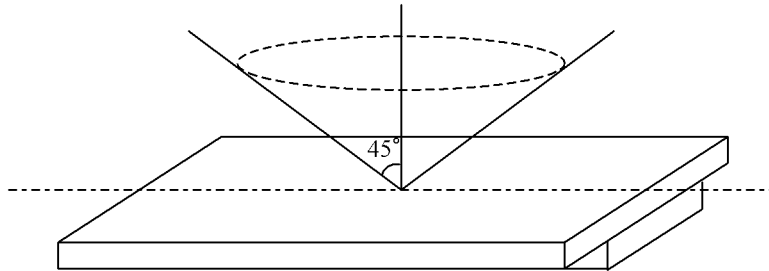

(a) Operating Inspection

The function and appearance shall be inspected in the condition of

- under 750 lx or over light ... Reflective Type.
- using over Backlight unit ... Transflective Type , Transmissive Type.

Condition of judgement

In case of no gradation display. It judges by applied On/Off voltage or optimal contrast.
In case of gradation display. It judges by contrast that the bad point is able to confirm best.

(b) Appearance Inspection

The appearance shall be inspected in the condition of

- under 500 lx or over light ... Reflective Type.
- using over Backlight unit ... Transflective Type , Transmissive Type.

(c) Inspection Environment

Inspection environment is carried out with 250 lx or less in principles.

6.2. Definition of applicable Zones

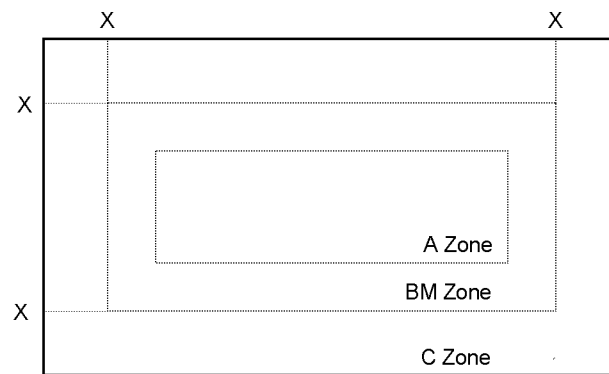

X : Maximum Seal Line

A Zone : Active display area

BM Zone : Out of active display area ~ Maximum seal line

C Zone : Rest parts

6.3.Standards

No.	Parameter	Criteria																																					
1	G Line	Nothing																																					
2	S Line	Nothing																																					
3	Bright and Dark dot	<p>The definition of bright pixel Uneven Luminous , which is Single Color Display of Black, White, Halftone R,G,B, is brighter than circumstace Pixel.</p> <p>The definition of dark pixel Uneven Luminous , which is Single Color Display of Black, White, Halftone R,G,B, is darker than circumstace Pixel.</p> <p>Continuous bright spot Vertical Continuous bright spot 3 horizontal continuous bright spot or equivalent is NG. 2 horizontal continuous bright spot or equivalent of uneven luminous are considered as 1 bright spot.</p> <table border="1"> <thead> <tr> <th>Zone</th> <th colspan="2">Acceptable Number</th> </tr> </thead> <tbody> <tr> <td rowspan="2">A</td> <td>Bright Dot</td> <td>0</td> </tr> <tr> <td>Dark Dot</td> <td>0</td> </tr> <tr> <td>BM</td> <td>Bright Dot</td> <td>0</td> </tr> </tbody> </table>	Zone	Acceptable Number		A	Bright Dot	0	Dark Dot	0	BM	Bright Dot	0																										
Zone	Acceptable Number																																						
A	Bright Dot	0																																					
	Dark Dot	0																																					
BM	Bright Dot	0																																					
4	Polarizer foreign material Assemble foreign material Surface defective CF foreign material B/L foreign material other (defective, which can not see at lighting inspection)	<p>(1) Round Shape</p> <table border="1"> <thead> <tr> <th rowspan="2">Dimension (mm) \ Zone</th> <th colspan="2">Acceptable Number</th> </tr> <tr> <th>A</th> <th>BM</th> </tr> </thead> <tbody> <tr> <td>$D \leq 0.10$</td> <td colspan="2">Disregard</td> </tr> <tr> <td>$0.10 < D \leq 0.15$</td> <td colspan="2">2</td> </tr> <tr> <td>$0.15 < D \leq 0.20$</td> <td colspan="2">1</td> </tr> <tr> <td>$0.20 < D$</td> <td colspan="2">0</td> </tr> </tbody> </table> <p>$D = (\text{Long} + \text{Short}) / 2$</p> <p>(2) Line Shape</p> <table border="1"> <thead> <tr> <th rowspan="2">X(mm) \ Y(mm) \ Zone</th> <th colspan="2">Acceptable Number</th> </tr> <tr> <th>A</th> <th>BM</th> </tr> </thead> <tbody> <tr> <td>- \ $W \leq 0.01$</td> <td colspan="2">Disregard</td> </tr> <tr> <td>$L \leq 2.0$ \ $W \leq 0.02$</td> <td colspan="2">2</td> </tr> <tr> <td>$L \leq 1.0$ \ $W \leq 0.03$</td> <td colspan="2">1</td> </tr> <tr> <td>$L > 2.0$ \ -</td> <td colspan="2">0</td> </tr> <tr> <td>- \ $W > 0.03$</td> <td colspan="2">0</td> </tr> </tbody> </table> <p>X : Length Y : Width Limit sample shall be determined by the arising demand.</p>	Dimension (mm) \ Zone	Acceptable Number		A	BM	$D \leq 0.10$	Disregard		$0.10 < D \leq 0.15$	2		$0.15 < D \leq 0.20$	1		$0.20 < D$	0		X(mm) \ Y(mm) \ Zone	Acceptable Number		A	BM	- \ $W \leq 0.01$	Disregard		$L \leq 2.0$ \ $W \leq 0.02$	2		$L \leq 1.0$ \ $W \leq 0.03$	1		$L > 2.0$ \ -	0		- \ $W > 0.03$	0	
Dimension (mm) \ Zone	Acceptable Number																																						
	A	BM																																					
$D \leq 0.10$	Disregard																																						
$0.10 < D \leq 0.15$	2																																						
$0.15 < D \leq 0.20$	1																																						
$0.20 < D$	0																																						
X(mm) \ Y(mm) \ Zone	Acceptable Number																																						
	A	BM																																					
- \ $W \leq 0.01$	Disregard																																						
$L \leq 2.0$ \ $W \leq 0.02$	2																																						
$L \leq 1.0$ \ $W \leq 0.03$	1																																						
$L > 2.0$ \ -	0																																						
- \ $W > 0.03$	0																																						

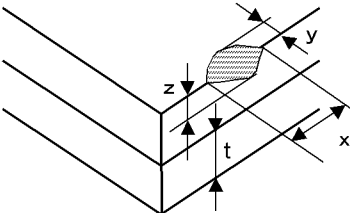
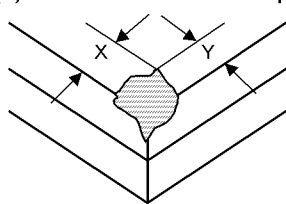
No.	Parameter	Criteria																	
5	Contrast Variation	Not to be conspicuous defects. Limit sample shall be determined by the arising demand.																	
6	Color Variation	Not to be conspicuous defects. Limit sample shall be determined by the arising demand. However, about the Color patches shall be two pieces or less which are same level as the limit sample.																	
7	Air Bubbles (between glass and polarizer)	<table border="1"> <thead> <tr> <th rowspan="2">Zone Dimension (mm)</th> <th colspan="2">Acceptable Number</th> </tr> <tr> <th>A</th> <th>BM</th> </tr> </thead> <tbody> <tr> <td>$D \leq 0.10$</td> <td colspan="2">Disregard</td> </tr> <tr> <td>$0.10 < D \leq 0.15$</td> <td colspan="2">1</td> </tr> <tr> <td>$0.15 < D \leq 0.20$</td> <td colspan="2">1</td> </tr> <tr> <td>$< D \leq 0.20$</td> <td colspan="2">0</td> </tr> </tbody> </table> <p>The polarizer edge has not floated. Limit sample shall be determined by the arising demand.</p>	Zone Dimension (mm)	Acceptable Number		A	BM	$D \leq 0.10$	Disregard		$0.10 < D \leq 0.15$	1		$0.15 < D \leq 0.20$	1		$< D \leq 0.20$	0	
Zone Dimension (mm)	Acceptable Number																		
	A	BM																	
$D \leq 0.10$	Disregard																		
$0.10 < D \leq 0.15$	1																		
$0.15 < D \leq 0.20$	1																		
$< D \leq 0.20$	0																		
8	Polarizer Scratches, Stroke marks	Not to be conspicuous defects. Limit sample shall be determined by the arising demand.																	
9	Polarizer Dirts	If the stains are removed easily from LCDP surface, the module is not defective.																	
10	Chipped Glass	<p>(1) Other than electrode pad areas and corner areas</p>  <table border="1"> <thead> <tr> <th>X</th> <th>Y</th> <th>Z</th> </tr> </thead> <tbody> <tr> <td>≤ 5.0</td> <td>≤ 0.5</td> <td>$\leq 1/2t$</td> </tr> </tbody> </table> <p>(2) Other than electrode pad Areas</p>  <p>$X \leq 1.5$ & $Y \leq 0.5$ or $X \leq 0.5$ & $Y \leq 1.5$</p> <p>*The direction of board thickness is disregarded.</p> <p>*For LCD module with holder It is disregard. When it has no problem for appearance, reliability and progressiveness.</p> <p>*For LCD module without holder The back side is disregard. When it has no problem for reliability and progressiveness.</p> <p>*It is not approved when a glass chip occurs with the part of the seal, wiring and terminal.</p>	X	Y	Z	≤ 5.0	≤ 0.5	$\leq 1/2t$											
X	Y	Z																	
≤ 5.0	≤ 0.5	$\leq 1/2t$																	

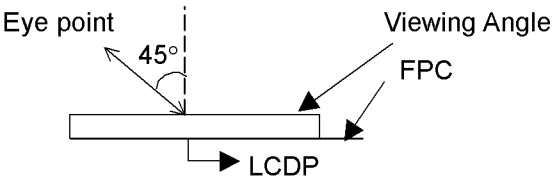
No.	Parameter	Criteria
11	Hot Spot	<p>See from the counter viewing angle. Jugement is based on Limit Sample.(043G-07005)</p>  <p>The diagram illustrates a viewing geometry for a hot spot inspection. It shows a horizontal line representing the LCDP (Liquid Crystal Display Panel) and FPC (Flexible Printed Circuit). An 'Eye point' is positioned above and to the left of the line. A vertical dashed line extends from the eye point down to the horizontal line. The angle between this vertical dashed line and the line of sight to the horizontal line is labeled as 45°. The 'Viewing Angle' is indicated by an arrow pointing to the 45-degree angle. The 'LCDP' and 'FPC' are labeled with arrows pointing to the horizontal line.</p>

7.Code System of Production Lot

The production lot of module is specified as follows.

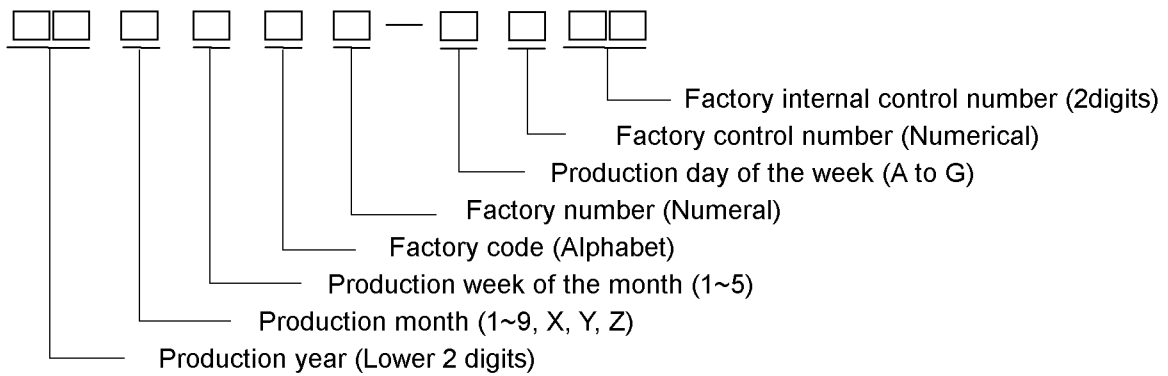

8.Type Number

The type number of module is specified as follows.

351909AC

9.Precautions under operation

When questions arise concerning this specifications or new problems not specified in this specifications arise, problems related to the specification is to be discussed for solution.

10. Precautions Relating Product Handling

The Following precautions will guide you in handling our product correctly.

1) Liquid crystal display devices

1. The liquid crystal display panel used in the liquid crystal display module is made of plate glass. Avoid any strong mechanical shock. Should the glass break handle it with care. The polarizer adhering to the surface of the LCD is made of a soft material. Guard against scratching it.



2) Care of the liquid crystal display module against static electricity discharge.

- 1. When working with the module, be sure to ground your body and any electrical equipment you may be using. We strongly recommend the use of anti static mats (made of rubber), to protect worktables against the hazards of electrical shock.**
- 2. Avoid the use of work clothing made of synthetic fibers. We recommend cotton clothing or other conductivity-treated fibers.**
- 3. Slowly and carefully remove the protective film from the LCD module, since this operation can generate static electricity.**

3) When the LCD module must be stored for long periods of time:

1. Protect the modules from high temperature and humidity.
Conditions: Temperature: 0°C~40°C
 Humidity : Less than 60%RH
 No dew condensation to be observed.
2. Keep the modules out of direct sunlight or direct exposure to ultraviolet rays.
3. Protect the modules from excessive external forces.

4) Use the module with a power supply that is equipped with an overcurrent protector circuit, since the module is not provided with this protective feature.

5) Do not ingest the LCD fluid itself should it leak out of a damaged LCD module. Should hands or clothing come in contact with LCD fluid, wash immediately with soap.

6) Conductivity is not guaranteed for models that use metal holders where solder connections between the metal holder and the PCB are not used. Please contact us to discuss appropriate ways to assure conductivity.

7) For models which use CFL:

1. High voltage of 1000V or greater is applied to the CFL cable connector area.
Care should be taken not to touch connection areas to avoid burns.
2. Protect CFL cables from rubbing against the unit and thus causing the wire jacket to become worn.
3. The use of CFLs for extended periods of time at low temperatures will significantly shorten their service life.
4. After storing the product (or LCD) under low temperature and/or in dark atmosphere for a long period of time, CCFL may take longer time to reach its specified brightness.

8) For models which use touch panels:

1. Do not stack up modules since they can be damaged by components on neighboring modules.
2. Do not place heavy objects on top of the product. This could cause glass breakage.

9) For models which use COG, TAB, or COF:

1. The mechanical strength of the product is low since the IC chip faces out unprotected from the rear. Be sure to protect the rear of the IC chip from external forces.
2. Given the fact that the rear of the IC chip is left exposed, in order to protect the unit from electrical damage, avoid installation configurations in which the rear of the IC chip runs the risk of making any electrical contact.

10) Models which use flexible cable, heat seal, or TAB:

1. In order to maintain reliability, do not touch or hold by the connector area.
2. Avoid any bending, pulling, or other excessive force, which can result in broken connections.

11) In case of buffer material such as cushion / gasket is assembled into LCD module, it may have an adverse effect on connecting parts (LCD panel-TCP / HEAT SEAL / FPC / etc., PCB-TCP / HEAT SEAL / FPC etc., TCP-HEAT SEAL, TCP-FPC, HEAT SEAL-FPC, etc.,) depending on its materials. Please check and evaluate these materials carefully before use.

12) In case of acrylic plate is attached to front side of LCD panel, cloudiness (very small cracks) can occur on acrylic plate, being influenced by some components generated from polarizer film. Please check and evaluate those acrylic materials carefully before use.

11. Warranty

This product has been manufactured to your company's specifications as a part for use in your company's general electronic products. It is guaranteed to perform according to delivery specifications. For any other use apart from general electronic equipment, we cannot take responsibility if the product is used in medical devices, nuclear power control equipment, aerospace equipment, fire and security systems, or any other applications in which there is a direct risk to human life and where extremely high levels of reliability are required. If the product is to be used in any of the above applications, we will need to enter into a separate product liability agreement.

1. We cannot accept responsibility for any defect, which may arise from additional manufacturing of the product (including disassembly and reassembly), after product delivery.
2. We cannot accept responsibility for any defect, which may arise after the application of strong external force to the product.
3. We cannot accept responsibility for any defect, which may arise due to the application of static electricity after the product has passed your company's acceptance inspection procedures.
4. When the product is in CFL models, CFL service life and brightness will vary according to the performance of the inverter used, leaks, etc. We cannot accept responsibility for product performance, reliability, or defect, which may arise.
5. We cannot accept responsibility for intellectual property of a third party, which may arise through the application of our product to your assembly with exception to those issues relating directly to the structure or method of manufacturing of our product.
6. Optrex will not be held responsible for any quality issue(s) after two years and beyond from its production date indicated on the lot number (please refer to "Code System of Production Lot" indicated earlier in this specification).