

DESCRIPTIONS

It is adaptable to a discontinuous mode of operation that the IP3002 is PFC (Power Factor Correction) controller for the high density switching mode power supply and electronic ballast systems. The bulky external components are eliminated in the internal start-up circuits, though it is taken in independent boost converter operation. What is more, instead of the external components, the low pass filter is mounted in internal current sense block. Internal clamping of the error amplifier and multiplier output improve turn on overshoot characteristics and current limiting. The one of features is able to prevent abnormal condition, open lamp & over voltage.

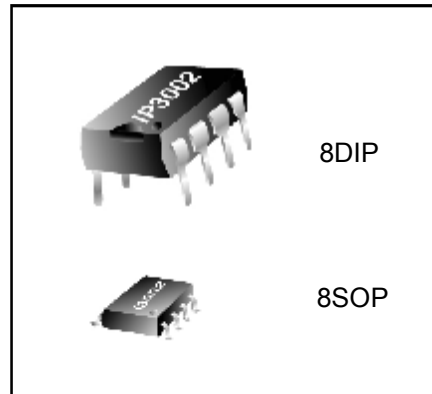

APPLICATIONS

- Switching Mode Power Supply (SMPS)
- Electronics Ballast

FEATURES

- Very Precise Adjustable Output OVP (Dynamic & Static OVP Function)
- Extremely Low Start-Up Current
- Very Low Operating Supply Current
- Internal Start-Up Timer
- Current Sense Filter On Chip
- Disable Function
- Extremely Minimized External Part Counts
- 8DIP / 8SOP package

ORDER INFORMATION

Device	Package	Operating Temp
IP3002	8DIP	-25°C ~ 125°C
I3002	8SOP	

BLOCK DIAGRAM

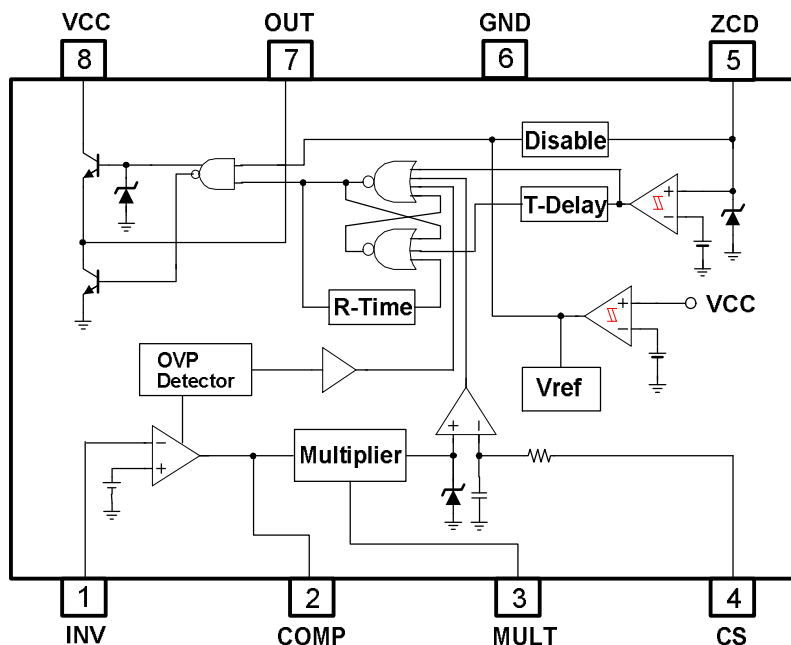

PIN CONNECTIONS

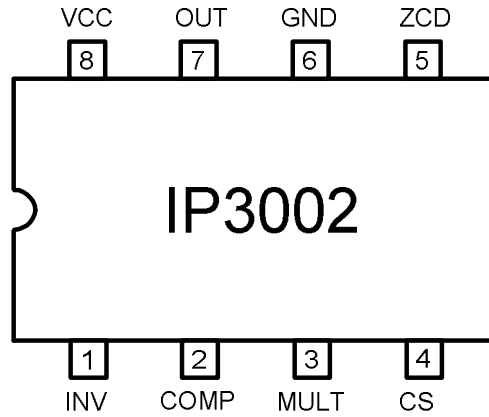

PIN DESCRIPTIONS

NO	SYMBOL	I/O	DESCRIPTION
1	INV	I	Inverting Input of Error Amplifier
2	COMP	O	Output of Error Amplifier
3	MULT	I	Input of The Multiplier Stage
4	CS	I	Current Sense Input
5	ZCD	I	Current Driven Logic Input
6	GND	-	Ground
7	OUT	O	Output
8	VCC	-	Supply Voltage

ABSOLUTE MAXIMUM RATINGS

CHARACTERISTICS	SYMBOL	VALUE	UNIT
Maximum Supply Voltage	VCCmax	27	V
Output Peak Current	Ipeak	500	mA
Analog Inputs & Outputs (Pin 1,2,3,4,5)	Vinmax	-0.3 ~ 7	V
ZCD Input Maximum Current	Izcd	±10	mA
Power Dissipation (8DIP)	Pdmax	800	mW
Power Dissipation (8SOP)	Pdmax	600	mW
Operating Temperature	Topr	-25 ~ 125	°C
Storage Temperature	Tstg	-65 ~ 150	°C

ELECTRICAL CHARACTERISTICS

(Ta = -25°C to 125°C, VCC=14V unless otherwise specified.)

CHARACTERISTICS	SYMBOL	CONDITIONS	MIN	TYP	MAX	UNIT
Supply Voltage & Current Section						
Start-up Threshold Voltage	Vth(st)	VCC Increasing	11	12	13	V
Hysteresis Voltage	HYS		2	2.5	3	V
Start-Up Current	Ist	Before Turn-On(VCC=11V)	20	50	90	uA
Quiescent Current	Iq	No Switching	1	4	7	mA
Operating Supply Current	Icc	CL=1nF,fsw=50KHz	2	5	8	mA
Operating Current at OVP	Icc_ovp	Vinv=2.7V	0.5	2	4	mA
Operating Current at Dis-able	Icc_dis	Vzcd<150mV	0.5	2	4	mA
Error Amplifier Section						
Input Volatge	Vinv	Ta=25°C	2.465	2.5	2.535	V
Line Regulation	dVinv	VCC=12 ~ 27V	-	0.1	5	mV
Input Bias Current	Iinv		-0.5	-0.1	0.5	uA
Open Loop Gain	Av		60	80	-	dB
Gain Bandwidth	GB		-	1	-	MHz
Output Source Current	Isource	Vcomp=4V,Vinv=2.4V	-2	-4	-	mA
Output Sink Current	Isink	Vcomp=4V,Vinv=2.6V	3	5	-	mA
Upper Clamp Voltage	Vupper	Io=-100uA,Vinv=2.4V	-	5.6	-	V
Lower Clamp Voltage	Vlower	Io=100uA,Vinv=2.6V	-	2.25	-	V

ELECTRICAL CHARACTERISTICS (Continued)

CHARACTERISTICS	SYMBOL	CONDITIONS	MIN	TYP	MAX	UNIT
Multiplier Section						
Linear Operating Voltage	Vmult		3	3.5	–	V
Output Maximum Slope	dVcs/dVmult	Vmult=0.5~0.9V, Vcomp=Upper Clamp	1.3	1.5	1.7	
Multiplier Gain	K	Ta=25°C Vmult=1V, Vcomp=3.5V	0.45	0.6	0.75	1/V
Current Sense (CS) Section						
Reference Clamp Voltage	Vcs	Vmult=2.5V, Vcomp=Upper Clamp	1.6	1.75	1.9	V
Input Bias Current	Ics	Vcs=0~1.6V	–1	0	1	uA
Zero Current Detector (ZCD) Section						
Input Threshold Voltage	Vzcd	Vzcd Increasing	1.8	2.1	2.4	V
Hysteresis Voltage	HY(zcd)		–	0.5	–	V
Upper Clamp Voltage	Vclamp(h)	Izcd=3mA	5	5.6	6.4	V
Lower Clamp Voltage	Vclamp(l)	Izcd=–3mA	0.3	0.65	–	V
Input Bias Current	Izcd	Vzcd=1~3V	–	1	–	uA
Source Current	Isource(zcd)		–3	–	–	mA
Sink Current	Isink(zcd)		3	–	–	mA
Disable Input Voltage	Vdis	Vzcd Decreasing	150	200	250	mV
Reset Current after Disable	Idis	Pin5=0V	–100	–200	–300	uA
Restart Timer Section						
Restart Time delay	trst		70	150	400	us

ELECTRICAL CHARACTERISTICS (Continued)

CHARACTERISTICS	SYMBOL	CONDITIONS	MIN	TYP	MAX	UNIT
Output Section						
High Voltage	Voh	Io = -10mA	11	12	13	V
Maximum Voltage	Vomax	VCC=20V, Io=-100uA	12	14	16	V
Low Voltage	Vol	Io=10mA	-	-	1	V
Voltage with UVLO Activated	Vo(uv)	Io=5mA	-	-	1	V
Rising Time	tr	CL=1nF	-	100	-	ns
Falling Time	tf	CL=1nF	-	50	-	ns
Over Voltage Protector (OVP) Section						
Dynamic OVP Bias Current	Iovp		35	40	45	uA
Static OVP Threshold Voltage	Vovp	Vinv=2.7V	2.1	2.25	2.4	V

APPLICATION INFORMATIONS

1. Main Inductor

$$L = \eta * (V_O - V_P) * V_P^2 / (4 * V_O * P_O * f)$$

Where,

η : Efficiency (0.95)
 V_O : DC Link Voltage
 V_P : Input Peak Voltage
 P_O : Output Power
 f : Switching Frequency

2. Resistor for Current Sense

$$R_S = 1.6 / I_{LP}$$

Where,

I_{LP} : Inductor Peak Current

3. Resistors for Multiplier

$$R_{ML} < 0.69 * R_{MU} / (V_P - 0.69)$$

Where,

R_{MU} : Upper Resistor for Multiplier Input
 R_{ML} : Lower Resistor for Multiplier Input

4. Resistors for Error Amplifier

$$R_{EL} = 2.5 * R_{EU} / (V_O - 2.5)$$

Where,

R_{EU} : Upper Resistor for Error Amplifier Inverting Input
 R_{EL} : Lower Resistor for Error Amplifier Inverting Input

APPLICATION INFORMATIONS (Continued)

5. Over Voltage Protector (OVP)

$$\Delta V_O[V] = R_{EU}[\Omega] * 40[\mu A]$$

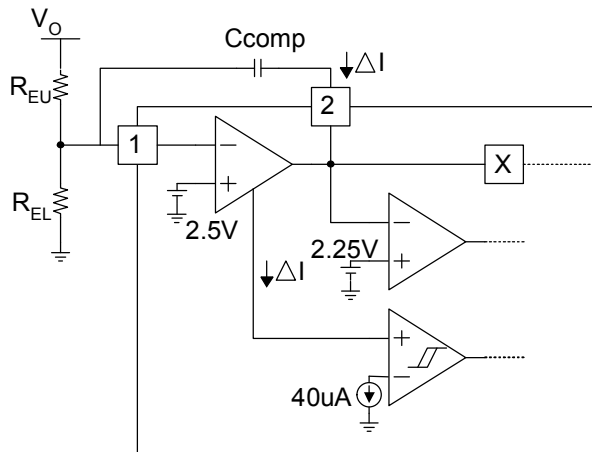

Fig.1 : Over Voltage Protection Circuit

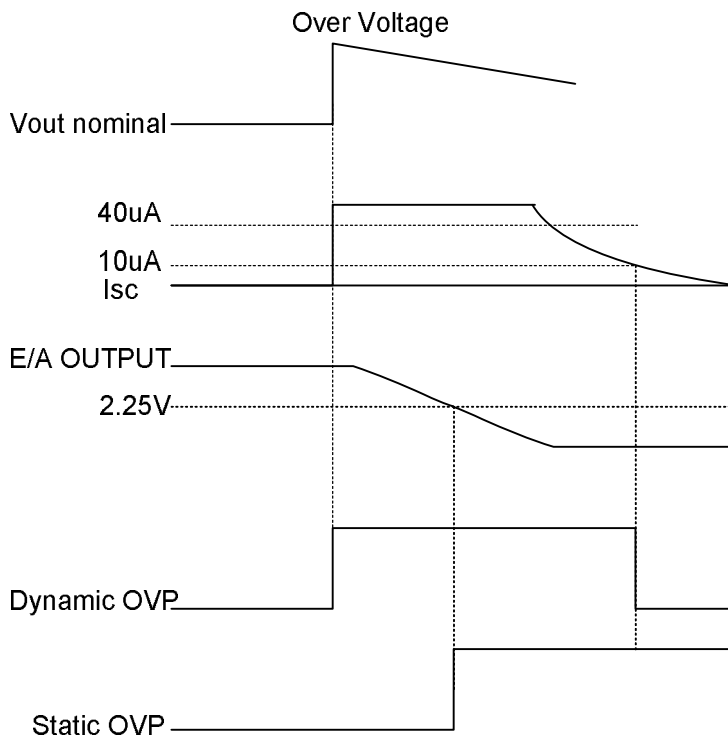
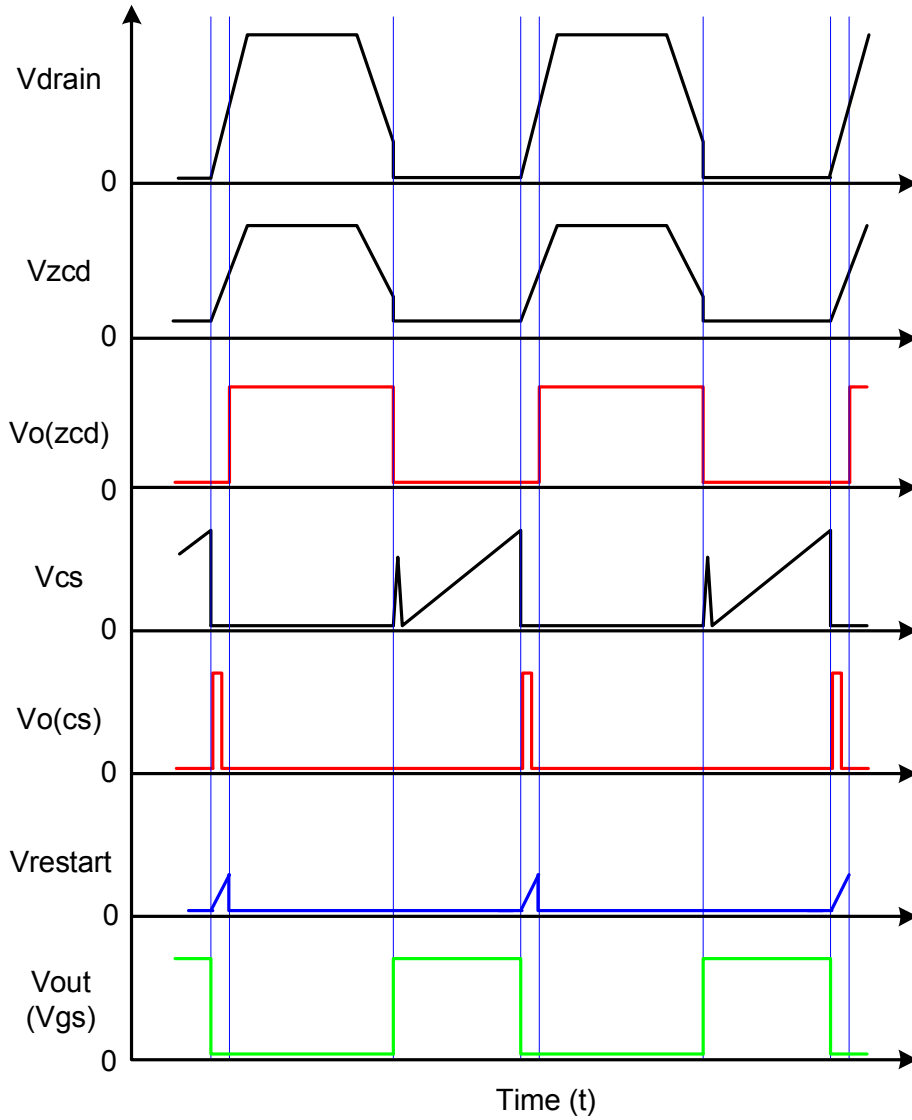
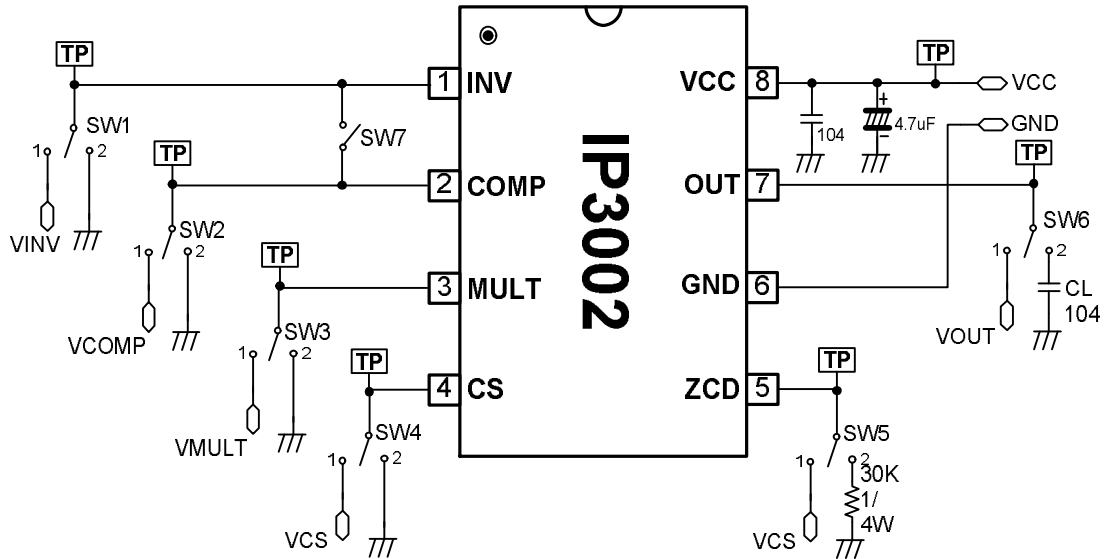

Fig.2: OVP Operation Timing Chart

OPERATING TIMING CHART



TEST CIRCUITS



TYPICAL APPLICATION CIRCUITS (80V_{AC} ~ 300V_{AC}, 80W)

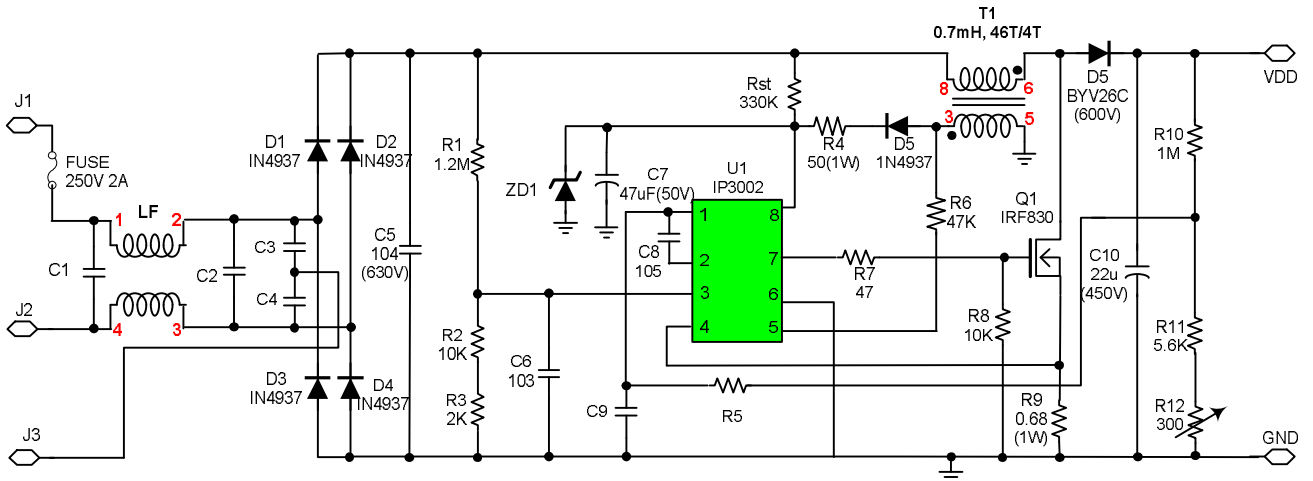

PACKAGE DIMENSION

8-DIP

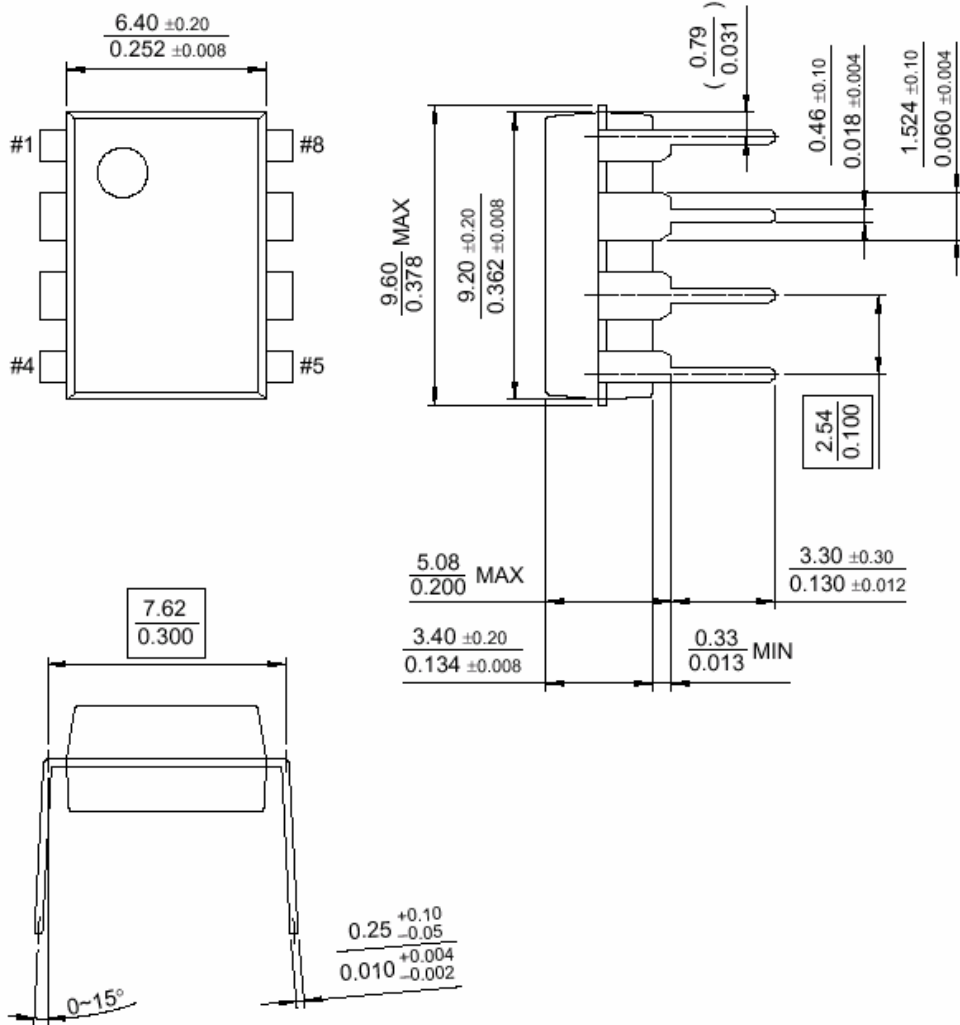

PACKAGE DIMENSION

8-SOP

