



AS2954

250 mA Low Drop Out Voltage Regulator

FEATURES

- Output Accuracy 5V, 3.3V, @ 250mA Output
- Very Low Quiescent Current
- Low Dropout Voltage
- Extremely Tight Load And Line Regulation
- Very Low Temperature Coefficient
- Current & Thermal Limiting
- Improved Replacement With High I_{OUT} For LP2954 Sockets

AS2954 Version Over LP2954

- Error Flag Warns Of Output Dropout
- Logic-Controlled Electronic Shutdown
- Output Programmable From 1.24V to 29V
- Input Can Withstand -20V Reverse Battery & +60 Positive Transient

APPLICATIONS

- Battery Powered Systems
- Cordless Telephones
- Radio Control Systems
- Portable/Palm Top/Notebook Computers
- Portable Consumer Equipment
- Portable Instrumentation
- Automotive Electronics
- SMPS Post-Regulator
- Voltage Reference
- Avionics

PRODUCT DESCRIPTION

The AS2954 is a low power voltage regulator. This device is an excellent choice for use in battery-powered applications such as cordless telephones, radio control systems, and portable computers. The AS2954 features very low quiescent current (75µA Typ.) and very low dropout voltage. This includes a tight initial tolerance of ± 0.5% max and ± 1% max., and very low output temperature coefficient, making the AS2954 useful as a low-power voltage reference. The key AS2954 features include protection against reversed battery, fold-back current limiting, and automotive load dump protection (60V positive transient).

The error flag output feature is used as power-on reset for warning of a low output voltage, due to falling voltage input of batteries. Another feature is the logic compatible shutdown input which enables the regulator to be switched on and off. The AS2954 is offered in a 3-pin TO-92 and TO-263 package compatible with other 5 volt regulators, in 8-Pin plastic, SO-8, (same pin out as AS2951), TO-220 and TO-263.

The regulator output voltage (of the 8-pin) may be pin-strapped for a 5V and 3.3V or programmed from 1.24V to 29V with an external pair of resistors. Look for AS2951 for 150mA and LP2951 for 100mA applications.

PIN CONNECTIONS

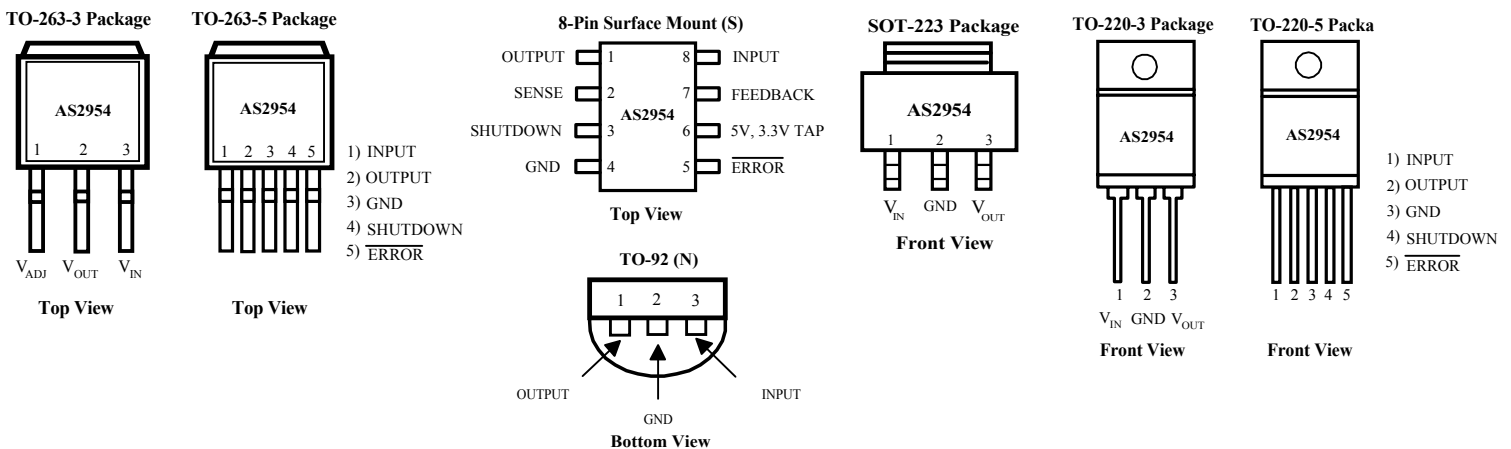

ORDERING INFORMATION

TO-263 3-PIN	TO-263 5-PIN	TO-92 3 PIN	TO-220 3 PIN	TO-220 5 PIN	PLASTIC SOIC 8 PIN	SOT-223 3 PIN	OPER. TEMP. RANGE
AS2954YT3-X	AS2954YT5-X	AS2954YN-X	AS2954YU3-X	AS2954YU5-X	AS2954YS-X	AS2954YM3-X	-40°C to +125°C

X= Output Voltage: (3.3 for 3.3V, 5.0 for 5.0V)

Y= Output Tolerance (A = 0.5%, Blank = 1%; B = 2%)

ABSOLUTE MAXIMUM RATINGS

Power Dissipation.....Internally Limited
 Lead Temp. (Soldering, 5 Seconds).....260°C
 Storage Temperature Range-65° to +150°C
 Operating Junction Temperature Range (Note 9)
 AS2954.....-40C° to +125°C

Input Supply Voltage-20V to +60V
 Feedback Input Voltage-1.5 to +30V
 Shutdown Input Voltage.....-0.3 to +30V
 Error Comparator Output.....-0.3 to +30V
 ESD Rating2KV Min

ELECTRICAL CHARACTERISTICS at $V_S = \pm 15V$, $T_A = 25^\circ C$, unless otherwise noted. **Boldface** applies over the full operating temperature range.

Parameter	Conditions	Typical	AS2954A		AS2954		AS2954B		Units
			Min	Max	Min	Max	Min	Max	
3.3V Version									
Output Voltage	$T_J = 25^\circ C$ $-25^\circ C \leq T_J \leq +85^\circ C$ $-40^\circ C \leq T_J \leq +125^\circ C$	3.3	3.284 3.267 3.260	3.317 3.333 3.340	3.267 3.251 3.234	3.333 3.201 3.366	3.234 3.201 3.194	3.366 3.399 3.432	V
Output Voltage	$1mA \leq I_L \leq 250mA$ $T_J \leq T_{JMAX}$	3.3	3.251	3.350	3.201	3.399	3.168	3.432	V
5V Version									
Output Voltage	$T_J = 25^\circ C$ $-25^\circ C \leq T_J \leq +85^\circ C$ $-40^\circ C \leq T_J \leq +125^\circ C$	5.0	4.975 4.95 4.94	5.025 5.050 5.06	4.95 4.925 4.90	5.05 5.075 5.10	4.90 4.85 4.84	5.10 5.15 5.20	V
Output Voltage	$1mA \leq I_L \leq 250mA$ $T_J \leq T_{JMAX}$	5.0	4.925	5.075	4.85	5.15	4.80	5.20	V
All Voltage Options									
Output Voltage Temperature Coefficient	(Note 1)	20		100		150		180	ppm/°C
Line Regulation (Note 3)	$6V \leq V_{IN} \leq 30V$ (Note 4)	0.03	0.10 0.20		0.20 0.40		0.40 0.60		%max
Load Regulation (Note 3)	$I_L = 1$ to 250 mA $I_L = 0.1$ to 1 mA	0.04		0.16 0.20		0.20 0.30		0.30 0.40	%max
Dropout Voltage (Note 5)	$I_L = 1mA$	60		100 150		100 150		100 150	mV
	$I_L = 50mA$	220		250 420		250 420		250 420	
	$I_L = 100mA$	250		300 450		300 450		300 450	
	$I_L = 250 mA$	375		450 600		450 600		450 600	
	Ground Current	$I_L = 1mA$	90		150 180		150 180		150 180
	$I_L = 50mA$	1		2 2.5		2 2.5		2 2.5	mA
	$I_L = 100mA$	4.5		6 8		6 8		6 8	
	$I_L = 250 mA$	21		14 16		20 22		26 28	
Current Limit	$V_{OUT} = 0$			550 600		550 600		550 600	mA
Thermal Regulation		0.05		0.2		0.2		0.2	%/w
Output Noise, 10Hz to 100kHz $I_L = 100mA$	$C_L = 2.2\mu F$	400							μV rms
	$C_L = 33 \mu F$	260							
8-Pin Versions only		Typical	AS2954A		AS2954		AS2954B		
Reference Voltage		1.235	1.220 1.200	1.250 1.260	1.210 1.200	1.260 1.270	1.200 1.190	1.270 1.280	V
Reference Voltage	Over Temperature (Note 6)		1.190	1.27	1.185	1.285	1.180	1.295	V
Feedback Pin Bias Current		20		40 60		40 60		40 60	nA
Reference Voltage Temperature Coefficient	(Note 7)	50							ppm/°C
Feedback Pin Bias Current Temperature Coefficient		0.1							nA/°C

(Continued)

Parameter	Conditions (Note 2)	Typical	AS2954A		AS2954		AS2954B		Units
			Min	Max	Min	Max	Min	Max	
Applies for AS2954YT5-X, AS2954YU5-X and AS2954YS-X									
Error Comparator									
Output Leakage Current	$V_{OH} = 30V$	0.01		100 2.00		100 2.00		100 2.00	μA
Output Low Voltage	$V_{IN} = 4.5V$ $I_{OL} = 400\mu A$	150		250 400		250 400		250 400	mV
Upper Threshold Voltage	(Note 8)	240	-320 -380	-150 -100	-320 -380	-150 -100	-320 -380	-150 -100	mV
Lower Threshold Voltage	(Note 8)	350	-450 -640	230 160	-450 -640	230 160	-450 -640	230 160	mV
Hysteresis	(Note 8)	60							mV
Shutdown Input									
V_{SD}	Output Turn-On Threshold Voltage		1.155 1.140	1.305 1.320	1.155 1.140	1.305 1.320	1.155 1.140	1.305 1.320	V
Hysteresis(HYST)		6							mV
Input Bias Current(I_B)	$V_{IN(SD)} = 0V$ to $5V$	10	-30 -50	-30 -50	-30 -50	-30 -50	-30 -50	-30 -50	nA

- Note 1:** Output or reference voltage temperature coefficients defined as the worst case voltage change divided by the total temperature range.
- Note 2:** Unless otherwise specified all limits are guaranteed for $T_J = 25^\circ C$, $V_{IN} = 6V$, $I_L = 100 \mu A$ and $C_L = 1\mu F$. Additional conditions for the 8-pin versions are feedback tied to 5V tap and output tied to output sense ($V_{OUT} = 5V$) and $V_{SHUTDOWN} \leq 0.8V$.
- Note 3:** Regulation is measured at constant junction temperature, using pulse testing with a low duty cycle. Changes in output voltage due to heating effects are covered under the specification for thermal regulation.
- Note 4:** Line regulation for the AS2954 is tested at $150^\circ C$ for $I_L = 1 mA$. For $I_L = 100\mu A$ and $T_J = 125^\circ C$, line regulation is guaranteed by design to 0.2%. See typical performance characteristics for line regulation versus temperature and load current.
- Note 5:** Dropout voltage is defined as the input to output differential at which the output voltage drops 100 mV below its nominal value measured at 1V differential at very low values of programmed output voltage, the minimum input supply voltage of 2V (2.3V over temperature) must be taken into account.
- Note 6:** $V_{REF} \leq V_{OUT} \leq (V_{IN} - 1V)$, $2.3 \leq V_{IN} \leq 30V$, $100\mu A \leq I_L \leq 250 mA$, $T_J \leq T_{JMAX}$.
- Note 7:** Comparator thresholds are expressed in terms of a voltage differential at the feedback terminal below the nominal reference voltage measured at 6V input. To express these thresholds in terms of output voltage change, multiply by the error amplifier gain = $V_{OUT}/V_{REF} = (R_1 + R_2)/R_2$. For example, at a programmed output voltage of 5V, the ERROR output is guaranteed to go low when the output drops by $95 mV \times 5V/1.235 = 384 mV$. Thresholds remain constant as a percent of V_{OUT} as V_{OUT} is varied, with the dropout warning occurring at typically 5% below nominal, 7.5% guaranteed.
- Note 8:** $V_{SHUTDOWN} \geq 2V$, $V_{IN} \leq 30V$, $V_{OUT} = 0$, feedback pin tied to 5V Tap.
- Note 9:** The junction -to-ambient thermal resistance of the TO-92 package is $180^\circ C/W$ with 0.4" leads and $160^\circ C/W$ with 0.25" leads to a PC board. The thermal resistance of the 8-Pin DIP package is $105^\circ C/W$ junction-to-ambient when soldered directly to a PC board. Junction-to-ambient thermal resistance for the SOIC (S) package is $160^\circ C/W$.

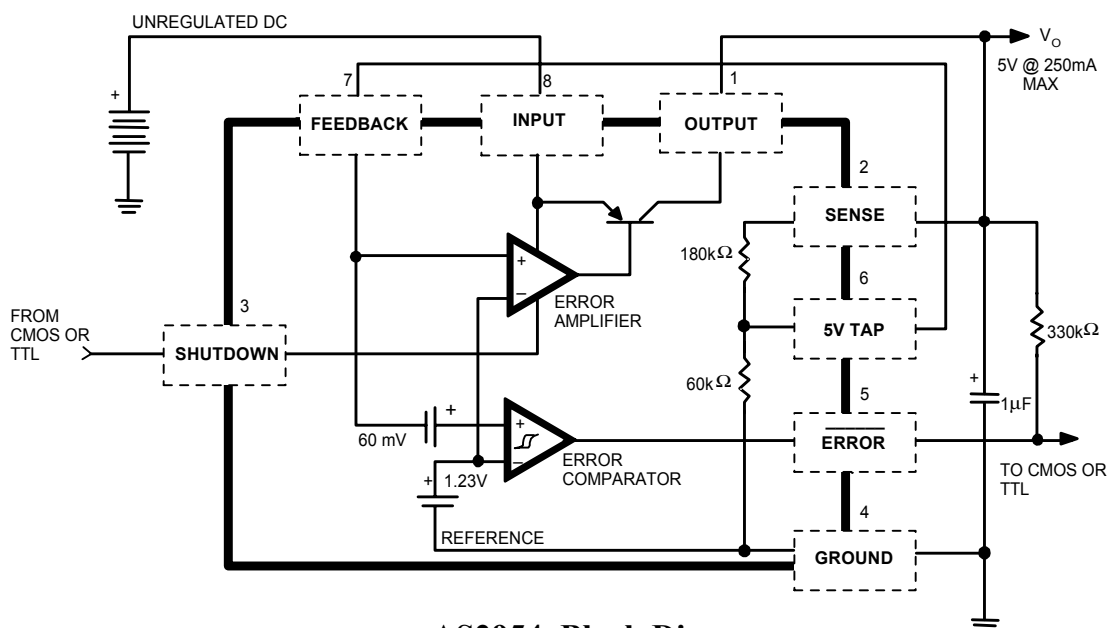

AS2954 Block Diagram

APPLICATION HINTS

EXTERNAL CAPACITORS

For the stability of the AS2954 requires a 2.2 μ F or greater capacitor between output and ground. Oscillation could occur without this capacitor. Most types of tantalum or aluminum electrolytic works fine here. For operations of below -25°C solid tantalum is recommended since the many aluminum types have electrolytes that freeze at about -30°C. The ESR of about 5 Ω or less and resonant frequency above 500kHz are the most important parameters in the value of the capacitor. The capacitor value can be increased without limit.

At lower values of output current, less output capacitance is required for stability. For the currents below 10mA the value of the capacitor can be reduced to 0.5 μ F and 0.15 μ F for 1mA. More output capacitance needed for the 8-pin version at voltages below 5V since it runs the error amplifier at lower gain. At worst case 5 μ F or greater must be used for the condition of 250mA load at 1.23V output.

The AS2954, unlike other low dropout regulators will remain stable and in regulation with no load in addition to the internal voltage divider. This feature is especially important in application like CMOS RAM keep-alive. When setting the output voltage of the AS2954, a minimum load of 1 μ A is recommended

If there is more than 10 inches of wire between the input and the AC filter capacitor or if a battery is used as the input then a 1 μ A tantalum or aluminum electrolytic capacitor should be placed from the input to the ground.

Instability can occur if there is stray capacitance to the AS2954 feedback terminal (pin 7). This could cause more problems when using a higher value of external resistors to set the output voltage.

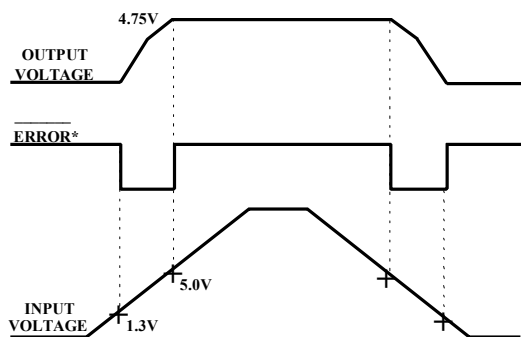

* See Application Info.

Figure 1. ERROR Output Timing

This problem can be fixed by adding a 100pF capacitor between output and feedback and increasing the output capacitor to at least 3.3 μ F.

ERROR DETECTION COMPARATOR OUTPUT

The Comparator produces a logic low output whenever the AS2954 output falls out of regulation by more than around 5%. This is around 60mV offset divided by the 1.235 reference voltage. This trip level remains 5% below normal regardless of the programmed output voltage of the regulator. Figure 1 shows the timing diagram depicting the ERROR signal and the regulator output voltage as the AS2954 input is ramped up and down. The ERROR signal becomes low at around 1.3V input, and goes high around 5V input (input voltage at which $V_{OUT} = 4.75$). Since the AS2954's dropout voltage is load dependent, the input voltage trip point (around 5V) will vary with the load current. The output voltage trip point (approx. 4.75V) does not vary with load.

The error comparator has an open-collector output, which requires an external pull-up resistor. Depending on the system requirements the resistor may be returned to 5V output or other supply voltage. In determining the value of this resistor, note that the output is rated to sink 400 μ A, this value adds to battery drain in a low battery condition. Suggested values range from 100K to 1M Ω . If the output is unused this resistor is not required.

PROGRAMMING THE OUTPUT VOLTAGE OF AS2954

The AS2954 may be pin-strapped for 5V using its internal voltage divider by tying Pin 1 (output) to Pin 2 (sense) and Pin 7 (feedback) to Pin 6 (5V Tap).

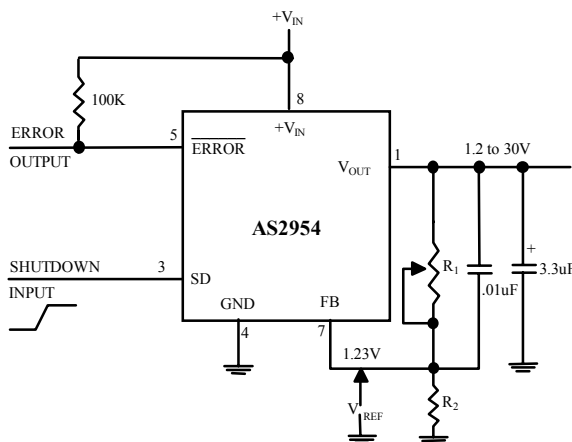

Figure 2. Adjustable Regulator

Also, it may be programmed for any output voltage between its 1.235V reference and its 30V maximum rating. As seen in Figure 2, an external pair of resistors is required. Refer to the below equation for the programming of the output voltage:

$$V_{OUT} = V_{REF} \times (1 + R_1/R_2) + I_{FB}R_1$$

The V_{REF} is 1.235 and I_{FB} is the feedback bias current, nominally -20nA. The minimum recommended load current of 1 μ A forces an upper limit of 1.2 M Ω on value of R_2 . If no load is presented the I_{FB} produces an error of typically 2% in V_{OUT} , which may be eliminated at room temperature by trimming R_1 . To improve the accuracy choose the value of $R_2 = 100k$ this reduces the error by 0.17% and increases the resistor program current by 12 μ A. Since the LP2951 typically draws 60 μ A at no load with Pin 2 open-circuited this is a small price to pay

HEATSINK REQUIREMENTS

Depending on the maximum ambient temperature and maximum power dissipation a heatsink may be required with the AS2954. The junction temperature range has to be within the range specified under Absolute Maximum Ratings under all possible operating conditions. To find out if a heatsink is required, the maximum power dissipation of the device needs to be calculated. This is the maximum specific AC voltage that must be taken into consideration at input. Figure 3 shows the condition and power dissipation which should be calculated with the following formula:

$$P_{TOTAL} = (V_{IN} - 5) I_L + (V_{IN})I_G$$

Next step is to calculate the temperature rise $T_{R(MAX)}$. $T_{J(MAX)}$ maximum allowable junction temperature, $T_A(MAX)$ maximum ambient temperature :

$$T_{R(MAX)} = T_{J(MAX)} - T_A(MAX)$$

Junction to ambient thermal resistance $\theta_{(J-A)}$ can be calculated after determining of P_{TOTAL} & $T_{R(MAX)}$:

$$\theta_{(J-A)} = T_{R(max)}/P_{(MAX)}$$

If the $\theta_{(J-A)}$ is 60°C/W or higher, the device could be operated without a heatsink. If the value is below 60°C/W then the heatsink is required and the thermal resistance of the heatsink can be calculated by the following formula, $\theta_{(J-C)}$ junction to case, $\theta_{(C-H)}$ case to heatsink, $\theta_{(H-A)}$ heatsink to ambient:

$$\theta_{(J-A)} = \theta_{(J-C)} + \theta_{(C-H)} + \theta_{(H-A)}$$

REDUCING OUTPUT NOISE

It may be an advantage to reduce the AC noise present at the output. One way is to reduce the regulator bandwidth by increasing the size of the output capacitor. This is the only way that noise can be reduced on the 3 lead AS2954 but is relatively inefficient, as increasing the capacitor from 1 μ F to 220 μ F only decreases the noise from 430 μ V to 160 μ V rms for a 100kHz bandwidth at 5V output. Noise could also be reduced fourfold by a bypass capacitor across R_1 , since it reduces the high frequency gain from 4 to unity. Pick

$$C_{BYPASS} \cong 1 / 2\pi R_1 \times 200 \text{ Hz}$$

or choose 0.01 μ F. When doing this, the output capacitor must be increased to 3.3 μ F to maintain stability. These changes reduce the output noise from 430 μ V to 100 μ V_{RMS} for a 100kHz bandwidth at 5V output. With the bypass capacitor added, noise no longer scales with output voltage so that improvements are more dramatic at higher output voltages.

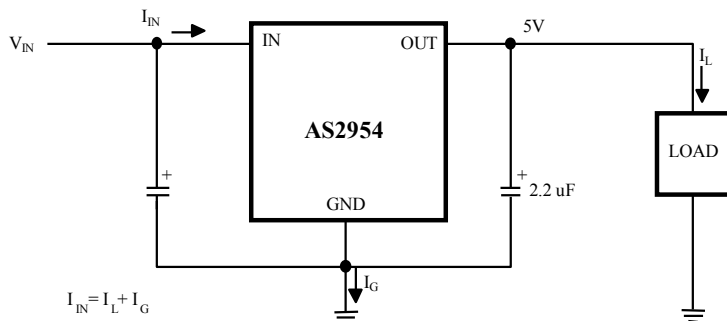
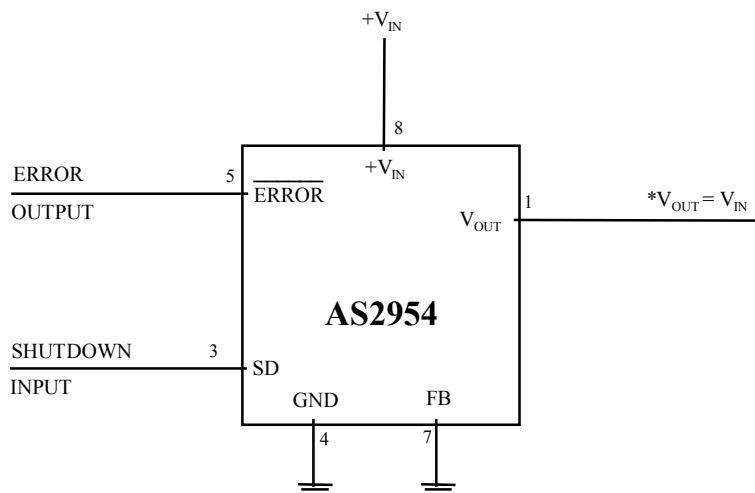

Figure 3. 5V Regulator Circuit

TYPICAL APPLICATIONS



*MINIMUM INPUT-OUTPUT VOLTAGE RANGES FROM 4mV TO 400mV. DEPENDENT ON LOAD CURRENT. CURRENT LIMIT IS TYPICALLY 160mA

Wide Input Voltage Range Current Limited

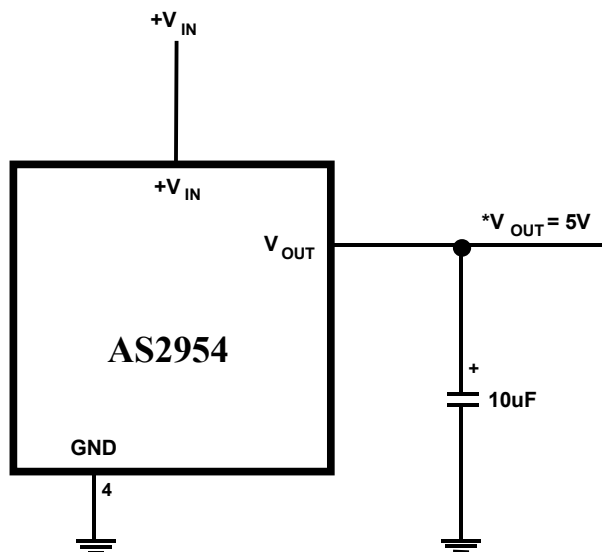

AS2954 FIXED +5V REGULATOR