

JANProduct Specification

	Model: GWTOC1SN9G1E0	Rev. No.	Issued Date.	Page.
		A	JUL. 13, 09	1 / 27

Thin-Film-Transistor LCD Module
Model: GWTOC1SN9G1E0

Acceptance

Solomon Goldentek Display Corp.
NO. 18 Ta-Yeh St., Ta-Fa Industrial Park, Ta-Liao
Hsiang, Kaohsiung Hsien 831, TAIWAN , R.O.C.
FAX: 886-7-7886800

Approved and Checked by

Approved by	Checked by		Made by
<i>David Lee</i> <i>JUL/13/09</i>		<i>David Lee</i> <i>JUL/13/09</i>	<i>Kobe Su</i> <i>JUL/13/09</i>

JAN Product Specification



Model: GWTOC1SN9G1E0

Rev. No.

Issued Date.

Page.

A

JUL. 13, 09

2 / 27

www.DataSheet4U.com

Revise Records

Rev.	Date	Contents	Written	Approved
A	2009/07/13	Preliminary Specification	Kobe_Su	David Lee

Special Notes

Note1.	
Note2.	
Note3.	
Note4.	
Note5.	

JAN Product Specification



Model: GWTOC1SN9G1E0

Rev. No.

Issued Date.

Page.

A

JUL. 13, 09

3 / 27

Contents

1. General Description and Features	4
1.1 Features	4
1.2 LCD Module	4
2. Mechanical Information	4
3. ABSOLUTE MAXIMUM RATINGS	5
3.1 Absolute Max. Ratings	5
4. Electrical Characteristics	6
5. Optical Characteristics	14
5.1 Optical characteristic of the LCD	14
6. I/O Terminal	17
6.1 Pin Assignment	17
6.2 Block Diagram	18
6.3 Basic Display Color and Gray Scale	19
7. Test	20
8. Appearance	21
8.1 Inspection	21
9. Precautions	22
9.1 Operation	22
9.2 Safety	22
9.3 Handling	22
9.4 Static electricity	24
9.5 Storage	24
9.6 Cleaning	24
9.7 Waste	24
10. Warranty	25
11. Dimensional Outlines	26

JAN Product Specification

	Model: GWTOC1SN9G1E0	Rev. No.	Issued Date.	Page.
		A	JUL. 13, 09	4 / 27

www.DataSheet4U.com

1. General Description and Features

GWTOC1SN9G1E0 is a transmissive type color active matrix TFT (Thin Film Transistor) liquid crystal display (LCD) that uses amorphous silicon TFT as a switching device. This model is composed of a TFT-LCD module, a driver circuit and a back-light unit. This TFT LCD has a 12.1(16:9)inch diagonally measured active display area with HD(1366 horizontal by 768 vertical pixel)resolution.

1.1 Features

- 12.1 (16:9 diagonal) inch configuration.
- One channel LVDS interface.
- 262K color by 6 bit R.G.B signal input.
- RoHS Compliance.
- Halogen Free

1.2 LCD Module

Item	Specification	Unit
Screen Size	12.1 inches	Diagonal
Display Resolution	1366 RGB (H) x 768 (V)	Pixel
Active Area	268.01 (H) x 150.68 (V)	mm
Outline Dimension	279 (H) x 167.2 (V) x 5.1 (T)	mm
Display Mode	Normally white mode/ Transmissive/ Wide view	--
Surface Treatment	Anti-glare , Hard-coating (3H)	--
Pixel Arrangement	R,G,B Vertical Stripe	--
Pixel pitch	0.1962 (H) x 0.1962 (V)	mm
NTSC	50	%
Viewing Direction	6 o'clock	--

2. Mechanical Information

Item	Min.	Typ.	Max.	Unit	
Module Size	Horizontal (H)	278.5	279	279.5	mm
	Vertical (V)	166.7	167.2	167.7	mm
	Thickness (T)	--	--	5.1	mm
Weight	--	250	265	g	

JAN Product Specification

	Model: GWTOC1SN9G1E0	Rev. No.	Issued Date.	Page.
		A	JUL. 13, 09	5 / 27

3. ABSOLUTE MAXIMUM RATINGS

3.1 Absolute Max. Ratings

3.1.1 Absolute Ratings of Environment

If the operating condition exceeds the following absolute maximum ratings, the TFT LCD module may be damaged permanently.

(Ta=25±2°C, V_{SS}=GND=0)

Item	Symbol	Min.	Max.	Unit	Note
Storage temperature	T _{STG}	-20	60	°C	(1)
Operating temperature	T _{OPR}	0	50	°C	(1,2,3)

Note (1) 95 % RH Max. (40 °C ≥ Ta). Maximum wet-bulb temperature at 39 °C or less. (Ta > 40 °C) No condensation.

Note (2) In case of below 0°, the response time of liquid crystal (LC) becomes slower and the color of panel becomes darker than normal one. Level of retardation depends on temperature, because of LC's character

Note (3) Only operation is guaranteed at operating temperature. Contrast, response time, another display quality are evaluated at +25°C.

3.2 Electrical Absolute Rating

3.2.1 TFT LCD Module

Item	Symbol	Min.	Max.	Unit	Note
Logic Supply voltage	V _{DD}	-0.3	6.0	V	

JAN Product Specification

	Model: GWTOC1SN9G1E0	Rev. No.	Issued Date.	Page.
		A	JUL. 13, 09	6 / 27

4. Electrical Characteristics

4.1 TFT LCD Module

Item	Symbol	Min.	Typ.	Max.	Unit	Note
Power supply	V_{DD}	3.0	3.3	3.6	V	Note (1)
Current of power supply	IDD	-	0.3	-	A	VDD=3.3V · L0 pattern
Inrush current	I_{RUSH}	-	-	1.5	mA	Note (2)

Note (1): V_{DD} -dip condition:

When VDD operating within $2.7V \leq VDD < 3.0V$, $t_d \leq 10ms$, the display may momentarily become abnormal.

$VDD < 2.7V$, VDD dip condition should also follow the Power On/Off conditions for supply voltage.

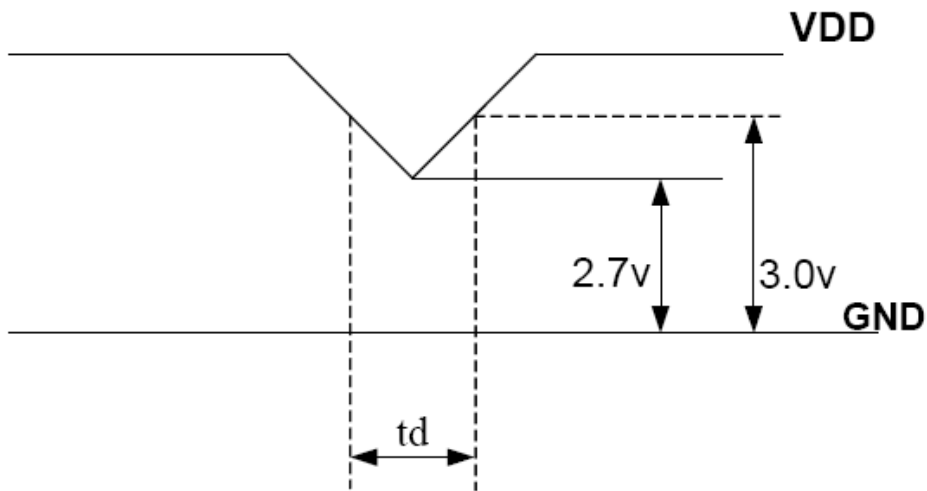

JAN Product Specification



Model: GWTOC1SN9G1E0

Rev. No.

Issued Date.

Page.

A

JUL. 13, 09

7 / 27

Note : (2) Power on Inrush current test circuit

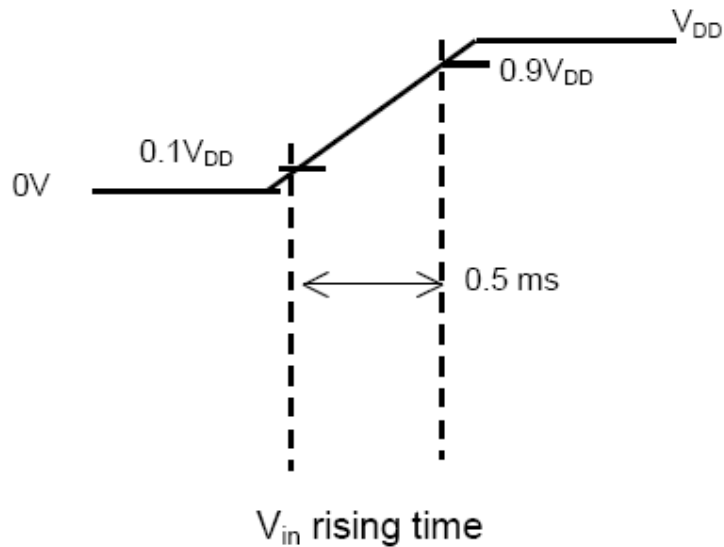
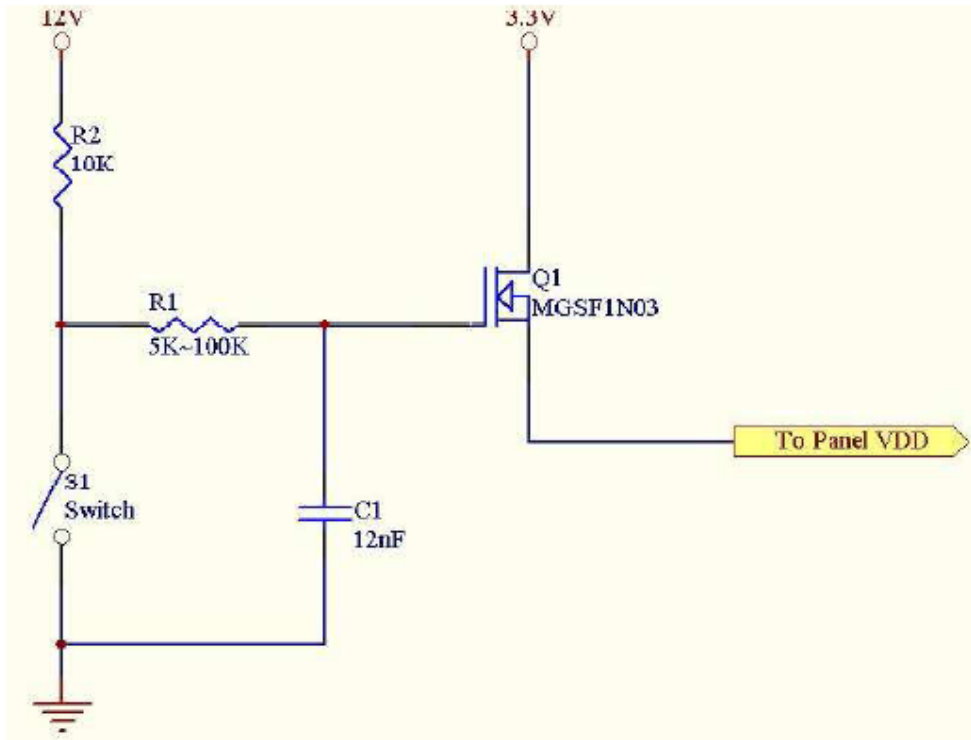

JAN Product Specification



Model: GWTOC1SN9G1E0

Rev. No.

Issued Date.

Page.

A

JUL. 13, 09

8 / 27

4.2 Switching Characteristics for LVDS Receiver

Item	Symbol	Min.	Typ.	Max.	Unit	Conditions
Differential Input High Threshold	V _{th}	--	--	100	mV	V _{CM} =1.2V
Differential Input Low Threshold	V _{tl}	-100	--	--	mV	
Input Current Differential input Voltage	I _{IN} V _{ID}	-10	--	+10	uA	
		0.1	--	0.6	V	
Common Mode Voltage Offset	V _{CM}	(V _{ID} /2)	1.25	1.8-0.4-(V _{ID} /2)	V	

4.3 Bit Mapping & Interface Definition

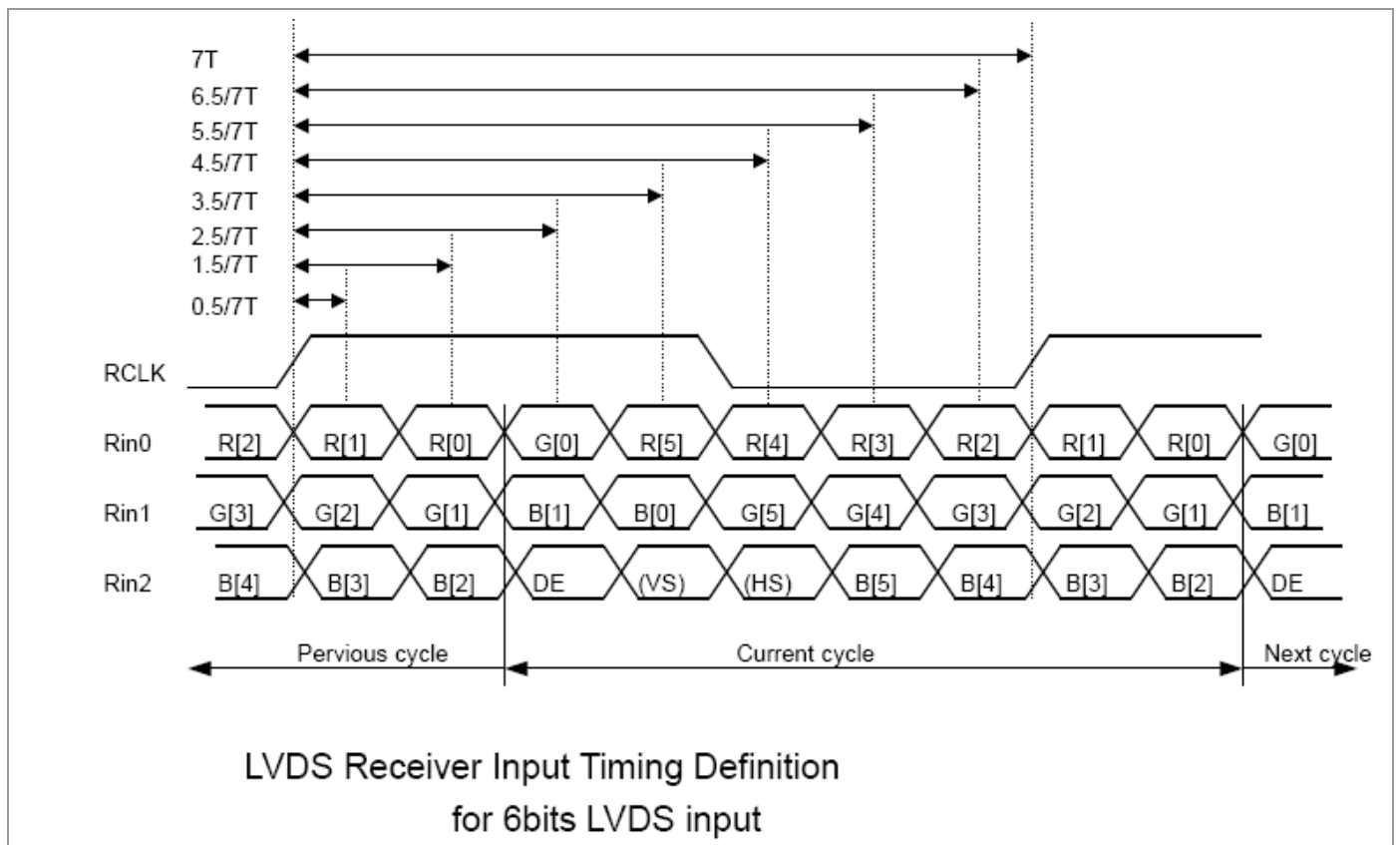

JAN Product Specification



Model: GWTOC1SN9G1E0

Rev. No.

Issued Date.

Page.

A

JUL. 13, 09

9 / 27

4.4 Interface Timing (DE mode)

Item	Symbol	Min.	Typ.	Max.	Unit
Frame Rate	--	55	60	--	Hz
Frame Period	t1	778	806	888	line
Vertical Display Time	t2	768	768	768	line
Vertical Blanking Time	t3	10	38	120	line
1 Line Scanning Time	t4	1437	1560	1936	clock
Horizontal Display Time	t5	1366	1366	1366	clock
Horizontal Blanking Time	t6	71	194	570	clock
Clock Rate	t7	50.3	75.44	80	MHz

Timing Diagram of Interface Signal (DE mode)

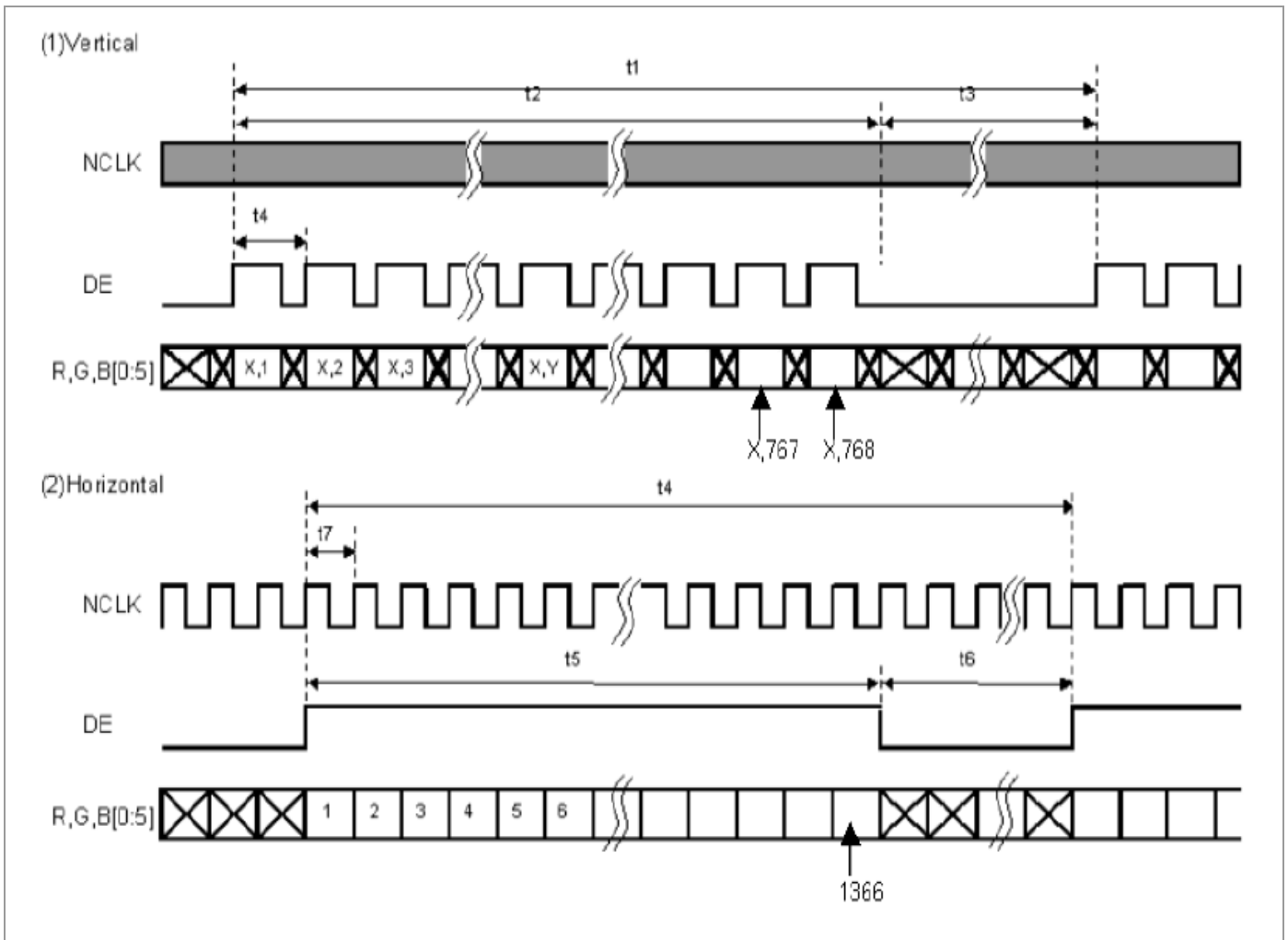

JAN Product Specification



Model: GWTOC1SN9G1E0

Rev. No.

Issued Date.

Page.

A

JUL. 13, 09

10 / 27

4.5 Power On / Off Sequence

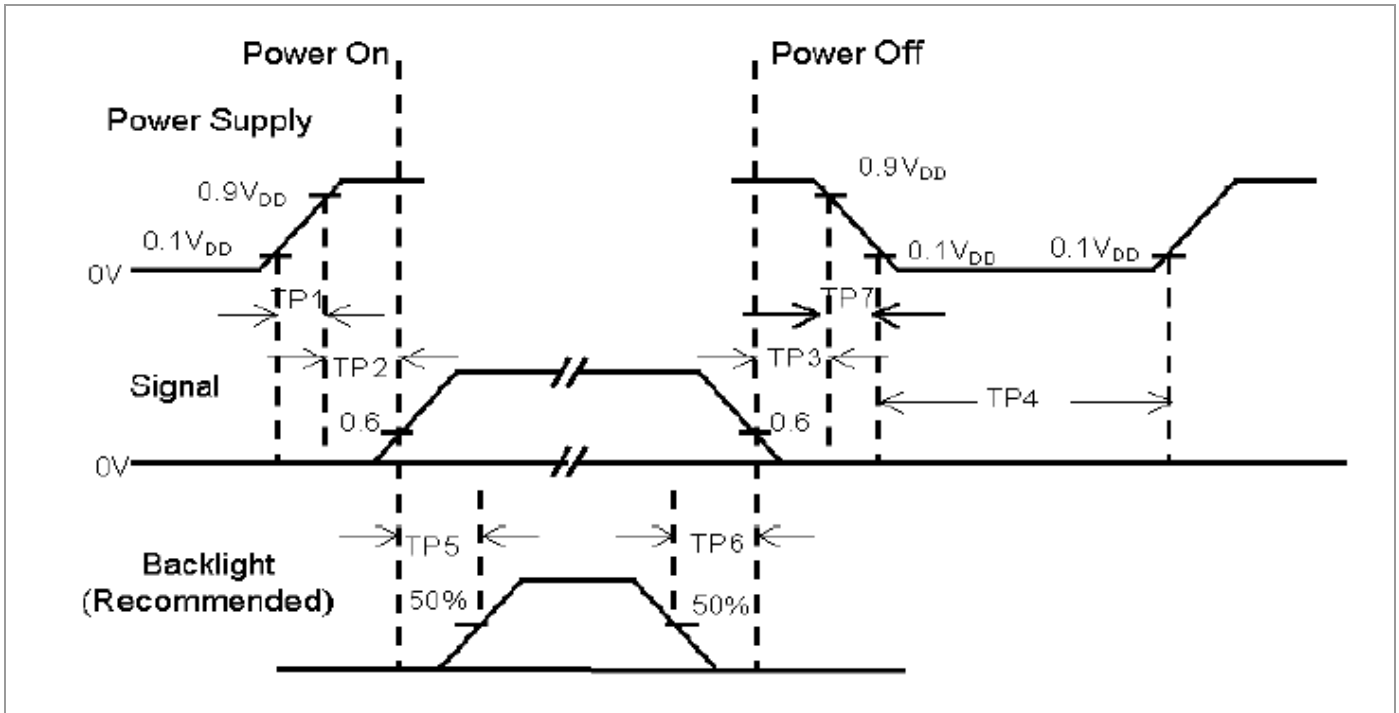

Item	Min.	Typ.	Max.	Unit	Remark
TP1	0.5	--	10	msec	
TP2	0	--	50	msec	
TP3	0	--	50	msec	
TP4	1000	--	--	msec	
TP5	200	--	--	msec	
TP6	200	--	--	msec	
TP7	0.5	--	10	msec	

- Note :
- (1) The supply voltage of the external system for the module input should be the same as the Definition of V_{DD} .
 - (2) Apply the lamp voltage within the LCD operation range. When the back-light turns on before the LCD operation or the LCD turns off before the back-light turns off, the display may momentarily become white.
 - (3) In case of V_{DD} =off level, please keep the level of input signal on the low or keep a high impedance.
 - (4) TP4 should be measured after the module has been fully discharged between power off and on period.
 - (5) Interface signal shall not be kept at high impedance when the power is on.

JAN Product Specification

	Model: GWTOC1SN9G1E0	Rev. No.	Issued Date.	Page.
		A	JUL. 13, 09	11 / 27

4.6 Backlight Unit

Parameter	Symbol	Min.	Typ.	Max.	Unit	Remark
LED Current	I_F	--	20	20.6	mA	Ta=25°C
LED Voltage	V_F	3.0	3.2	3.4	Volt	Ta=25°C
LED Power consumption	I_F	--	1.92	2.1	Watt	Ta=25°C Note(1)
LED Life-Time	N/A	10,000	--	--	Hour	Ta=25°C Note(2)

Note (1): Calculator value for reference $P = I_F \times V_F \times N$ (LED Qty')

Note (2): The LED lifetime defines as the estimated time to 50% degradation of final luminous.

4.7 LED Driver

4.7.1 Absolute Maximum Ratings

Item	Symbol	Min.	Max.	Unit	Note
LED Power Supply voltage	V_{LED}	-0.3	24	Volt	
LED_EN,PWM pin Voltage	V_{EN}, V_{PWM}	--	5.5	Volt	

4.7.2 DC Electrical Characteristics

Parameter	Symbol	Min.	Typ.	Max.	Unit	Remark
LED Power Supply Voltage	V_{LED}	7.0	--	21.0	Volt	
LED_EN High Threshold	V_{ENH}	2.0	--	--	Volt	
LED_EN Low Threshold	V_{ENL}	--	--	0.3	Volt	
PWM High Threshold	V_{PWMH}	2.0	--	--	Volt	
PWM Low Threshold	V_{PWML}	--	--	0.15	Volt	
PWM Frequency	F_{PWM}	225	--	275	Volt	
PWM Duty Cycle	T_D	10	--	100	Volt	Note(1)

JAN Product Specification



Model: GWTOC1SN9G1E0

Rev. No.

Issued Date.

Page.

A

JUL. 13, 09

12 / 27

Note (1): PWM Duty Cycle

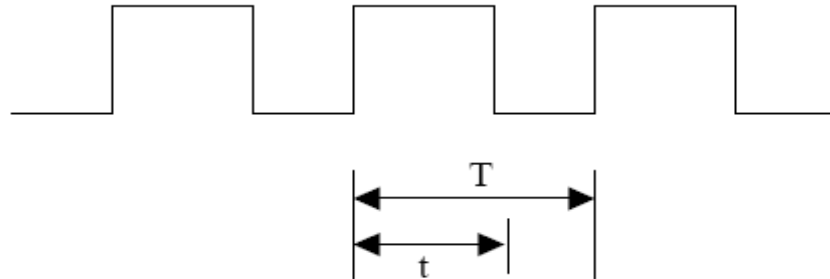

$$\text{Duty Cycle} = (t / T) * 100\%$$

4.7.3 LED Power on / off sequence

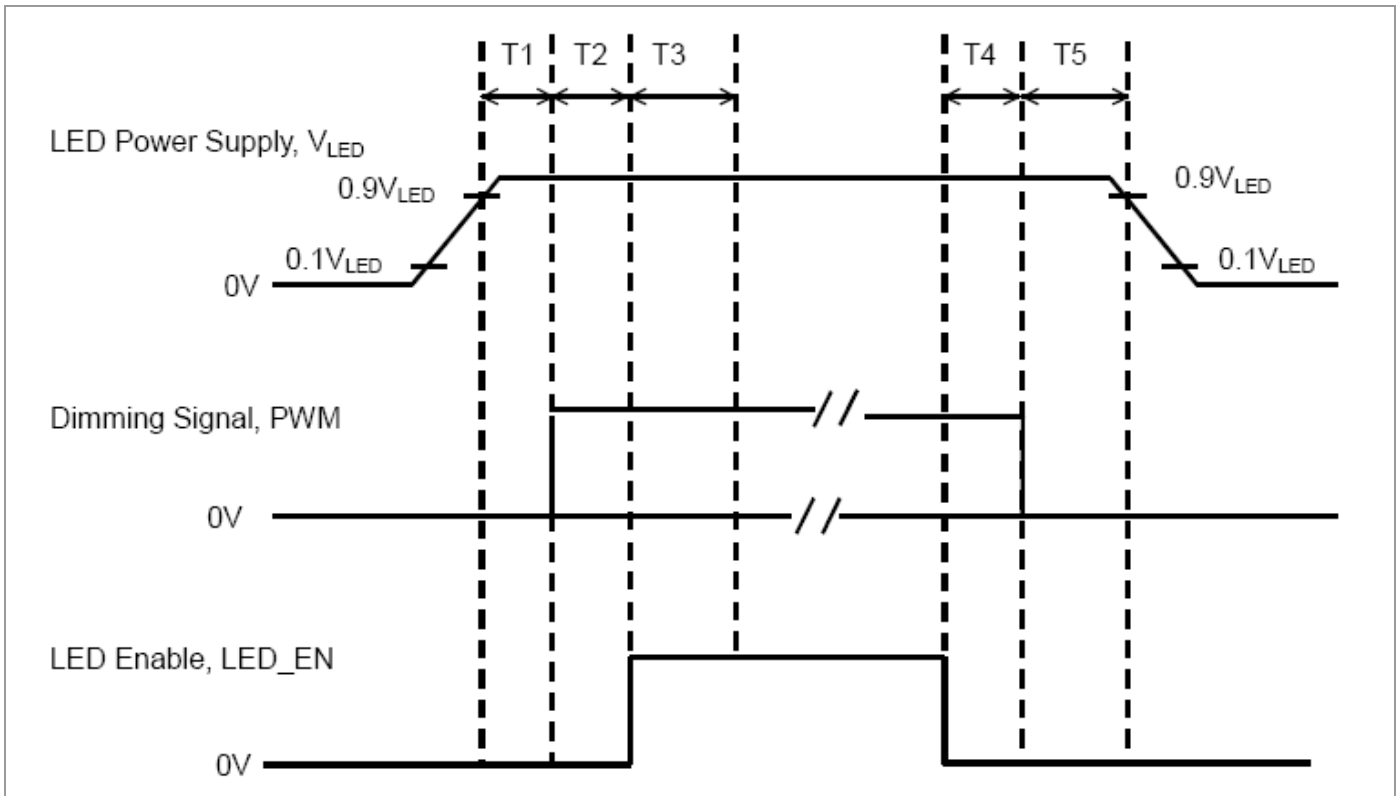

JAN Product Specification

	Model: GWTOC1SN9G1E0	Rev. No.	Issued Date.	Page.
		A	JUL. 13, 09	13 / 27

Symbol	Value			Unit
	Min.	Typ.	Max.	
T1	10	--	--	ms
T2	10	--	--	
T3	50	--	--	
T4	0	--	--	
T5	10	--	--	

Note (1) : The duty of LED dimming signal should be more than 20% in T2 and T3

Note (2) : PWM can adjust brightness to control Pin. Pulse duty the bigger the brighter.

JAN Product Specification

	Model: GWTOC1SN9G1E0	Rev. No.	Issued Date.	Page.
		A	JUL. 13, 09	14 / 27

5. Optical Characteristics

5.1 Optical characteristic of the LCD

The following items are measured under stable conditions. The optical characteristics should be measured in a dark room or equivalent state.

Measuring equipment: BM-5A, BM-7A

Item	Symbol	Condition	Min	Type	Max	Unit	Note
White luminance	Y_L		160	200	--	cd/m ²	
Response time	T_r	$\theta=0^\circ$	--	3	6	ms	.
	T_f		--	9	8	ms	
Contrast ratio	CR	At optimized viewing angle	400	500	--	--	
Color Gamut	NTSC %	--	70	--	--	%	
Color Chromaticity (CIE 1931)	Red	R_x	$\theta=0^\circ$ Normal Viewing Angle	0.561	0.591	0.621	--
		R_y		0.324	0.354	0.384	
	Green	G_x		0.293	0.322	0.352	--
		G_y		0.517	0.547	0.577	
	Blue	B_x		0.123	0.153	0.183	--
		B_y		0.068	0.098	0.128	
	White	W_x		0.283	0.313	0.343	--
		W_y		0.299	0.329	0.359	
Viewing Angle (6H)	Hor.	θ_R	$CR \geq 10$	40	45	--	Degree
		θ_L		40	45	--	
	Ver.	ϕ_H		10	15	--	
		ϕ_L		30	35	--	

JAN Product Specification

	Model: GWTOC1SN9G1E0	Rev. No.	Issued Date.	Page.
		A	JUL. 13, 09	15 / 27

a. Test equipment setup

After stabilizing and leaving the panel alone shall be warmed up for the stable operation of LCM, the measurement should be executed. Measurement should be executed in a stable, windless, and dark room. Optical specifications are measured by Topcon BM-7A(fast) with a viewing angle of 2° at a distance of 50cm and normal direction.

b. Definition of response time: Tr and Tf

The response time is defined as the following figure and shall be measured by switching the input signal for "black" and "white".

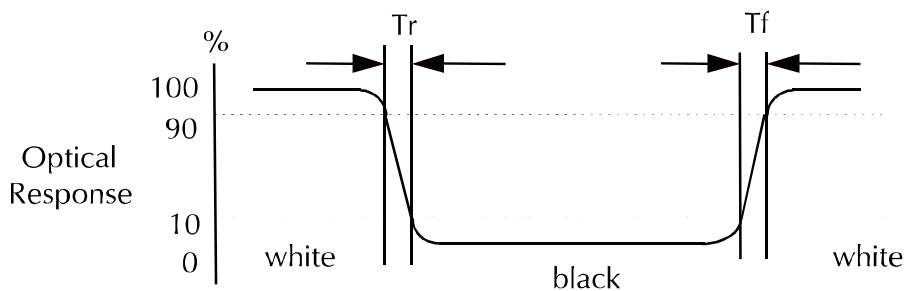

c. Definition of contrast ratio:

$$\text{Contrast Ratio (CR)} = \frac{\text{Brightness measured when LCD is at "white state"}}{\text{Brightness measured when LCD is at "black state"}}$$

d. Measured at the center area of the panel when all the input terminals of LCD panel are electrically opened.

JAN Product Specification

	Model: GWTOC1SN9G1E0	Rev. No.	Issued Date.	Page.
		A	JUL. 13, 09	16 / 27

e. View Angle

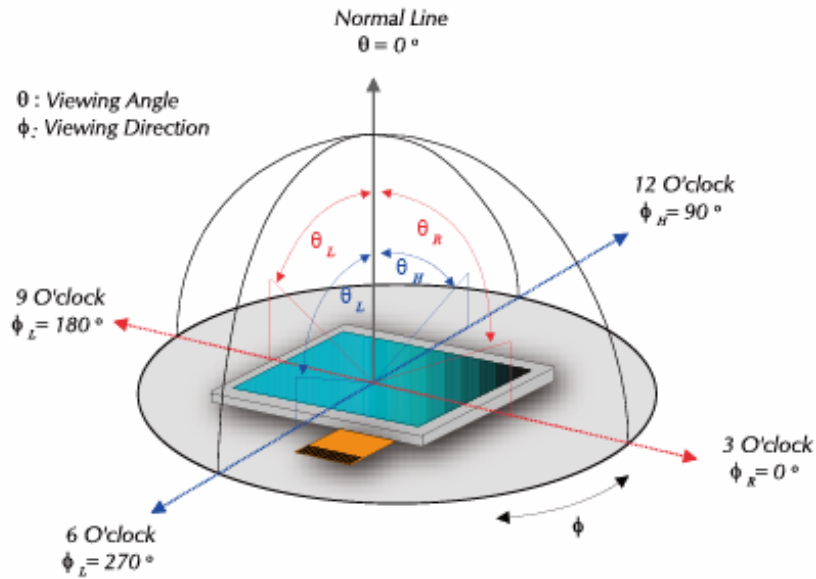

f. Definition of Luminance of White: Luminance of white at the center points

Light Source of Back-Light Unit	LED Type
---------------------------------	----------

g. Definition of White Uniformity

$$\text{White Uniformity} = \frac{\text{Min. luminance of white among 5-points}}{\text{Max. luminance of white among 5-points}}$$

h. The definition of Color Gamut -Color Chromaticity CIE 1931

Color coordinate of white & red, green, blue at center point.

Color Gamut : NTSC(%) = (RGB Triangle Area / NTSC Triangle Area) x 100

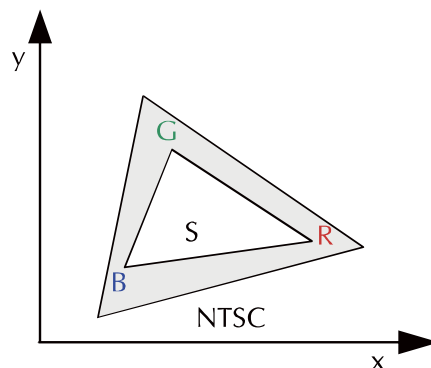

JAN Product Specification

	Model: GWTOC1SN9G1E0	Rev. No.	Issued Date.	Page.
		A	JUL. 13, 09	17 / 27

6. I/O Terminal

6.1 Pin Assignment

Pin No.	Symbol	Function	Remark
1	GND	Ground	
2	VDD	3.3V Power	
3	VDD	3.3V Power	
4	V_EDID	3.3 V Power for EDID	
5	PWM	System PWM Signal Input	
6	CLK_EDID	EDID Clock Input	
7	DATA_EDID	EDID Data Input	
8	RXIN0-	LVDS Signal- channe10-	
9	RXIN0+	LVDS Signal+ channe10+	
10	GND	Ground	
11	RXIN1-	Data Input channel1-	
12	RXIN1+	Data Input channel1+	
13	GND	Ground	
14	RXIN2-	Data Input channel2-	
15	RXIN2+	Data Input channel2+	
16	GND	Ground	
17	RXCLKIN-	Data Input CLK-	
18	RXCLKIN+	Data Input CLK+	
19	GND	Ground	
20	NC	No Connection	
21	NC	No Connection	
22	GND	Ground	
23	GND	Ground	
24	VLED	LED Input voltage 7V~21V	
25	VLED	LED Input voltage 7V~21V	
26	VLED	LED Input voltage 7V~21V	
27	LED_EN	LED Enable Signal	
28	NC	No Connection	
29	NC	No Connection	
30	NC	No Connection	

JAN Product Specification



Model: GWTOC1SN9G1E0

Rev. No.

Issued Date.

Page.

A

JUL. 13, 09

18 / 27

6.2 Block Diagram

6.2.1 TFT LCD Module

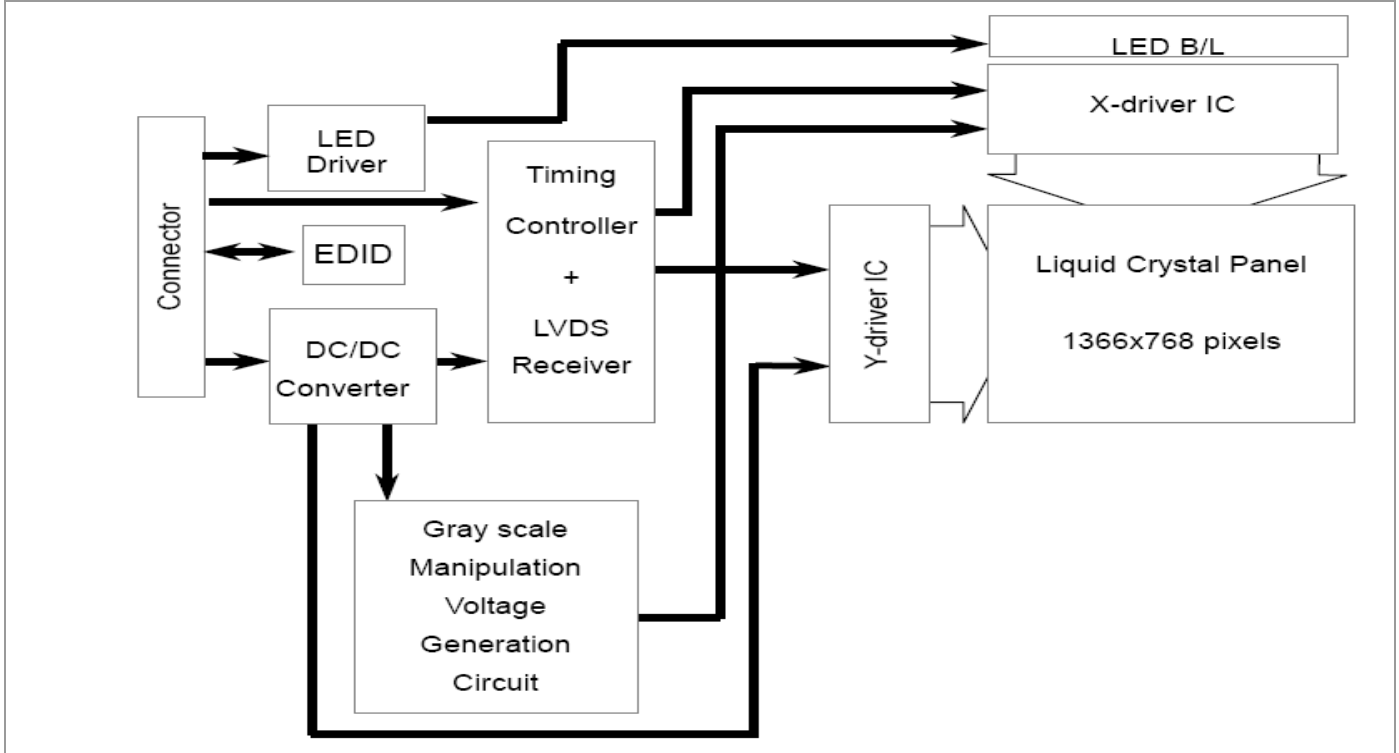

6.2.2 Pixel Format

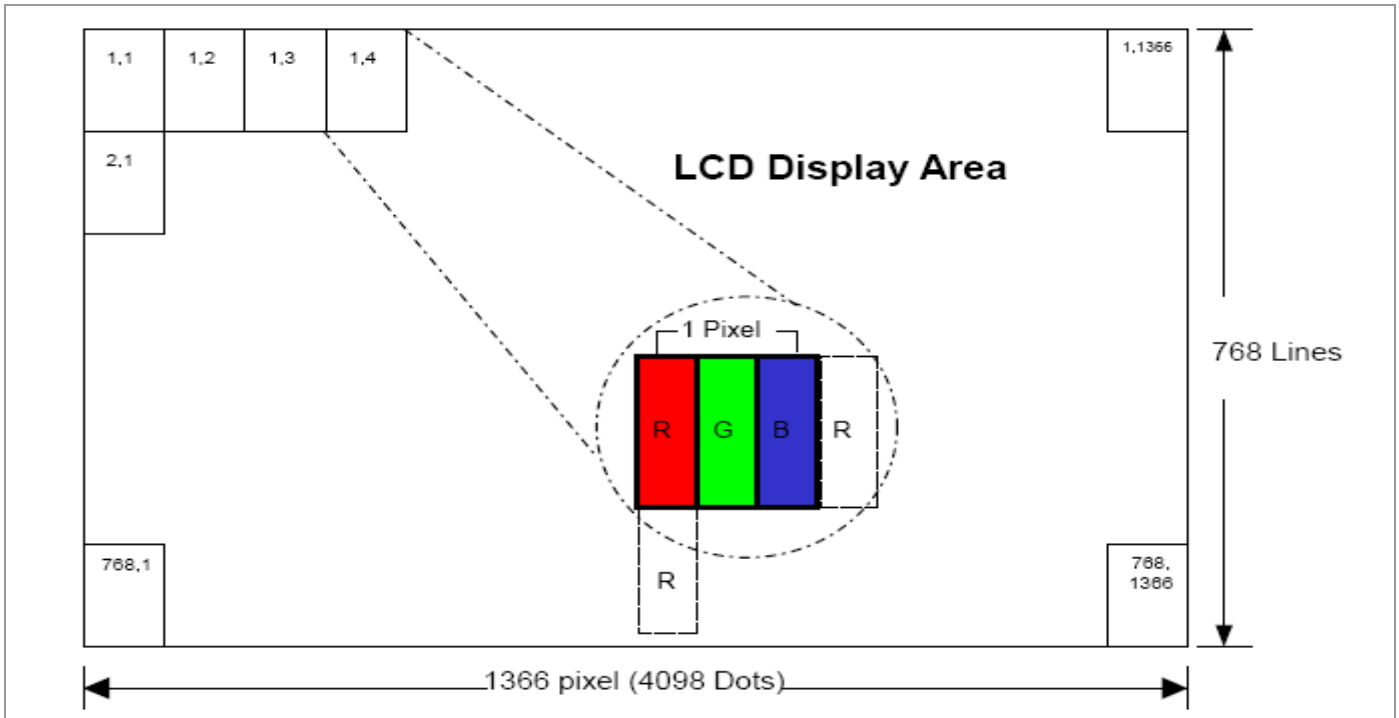

JAN Product Specification

	Model: GWTOC1SN9G1E0	Rev. No.	Issued Date.	Page.
		A	JUL. 13, 09	19 / 27

6.3 Basic Display Color and Gray Scale

	Color & Gray Scale	Data Signal																	
		R5	R4	R3	R2	R1	R0	G5	G4	G3	G2	G1	G0	B5	B4	B3	B2	B1	B0
Basic Color	Black	0	0	0	0	0	0	0	0	0	0	0	0	0	0	0	0	0	0
	Red(0)	1	1	1	1	1	1	0	0	0	0	0	0	0	0	0	0	0	0
	Green(0)	0	0	0	0	0	0	1	1	1	1	1	1	0	0	0	0	0	0
	Blue(0)	0	0	0	0	0	0	0	0	0	0	0	0	1	1	1	1	1	1
	Cyan	0	0	0	0	0	0	1	1	1	1	1	1	1	1	1	1	1	1
	Magenta	1	1	1	1	1	1	0	0	0	0	0	0	1	1	1	1	1	1
	Yellow	1	1	1	1	1	1	1	1	1	1	1	1	0	0	0	0	0	0
	White	1	1	1	1	1	1	1	1	1	1	1	1	1	1	1	1	1	1
Red	Black	0	0	0	0	0	0	0	0	0	0	0	0	0	0	0	0	0	0
	Red(1)	0	0	0	0	0	1	0	0	0	0	0	0	0	0	0	0	0	0
	Red(2)	0	0	0	0	1	0	0	0	0	0	0	0	0	0	0	0	0	0
	:	:	:	:	:	:	:	:	:	:	:	:	:	:	:	:	:	:	:
	Red(31)	1	1	1	1	1	1	0	0	0	0	0	0	0	0	0	0	0	0
	:	:	:	:	:	:	:	:	:	:	:	:	:	:	:	:	:	:	:
	Red(62)	1	1	1	1	1	0	0	0	0	0	0	0	0	0	0	0	0	0
	Red(63)	1	1	1	1	1	1	0	0	0	0	0	0	0	0	0	0	0	0
Green	Black	0	0	0	0	0	0	0	0	0	0	0	0	0	0	0	0	0	0
	Green(1)	0	0	0	0	0	0	0	0	0	0	0	1	0	0	0	0	0	0
	Green(2)	0	0	0	0	0	0	0	0	0	0	1	0	0	0	0	0	0	0
	:	:	:	:	:	:	:	:	:	:	:	:	:	:	:	:	:	:	:
	Green(31)	0	0	0	0	0	0	1	1	1	1	1	1	0	0	0	0	0	0
	:	:	:	:	:	:	:	:	:	:	:	:	:	:	:	:	:	:	:
	Green(62)	0	0	0	0	0	0	1	1	1	1	1	0	0	0	0	0	0	0
	Green(63)	0	0	0	0	0	0	1	1	1	1	1	1	0	0	0	0	0	0
Blue	Black	0	0	0	0	0	0	0	0	0	0	0	0	0	0	0	0	0	0
	Blue(1)	0	0	0	0	0	0	0	0	0	0	0	0	0	0	0	0	0	1
	Blue(2)	0	0	0	0	0	0	0	0	0	0	0	0	0	0	0	0	1	0
	:	:	:	:	:	:	:	:	:	:	:	:	:	:	:	:	:	:	:
	Blue(31)	0	0	0	0	0	0	0	0	0	0	0	0	1	1	1	1	1	1
	:	:	:	:	:	:	:	:	:	:	:	:	:	:	:	:	:	:	:
	Blue(62)	0	0	0	0	0	0	0	0	0	0	0	0	1	1	1	1	1	0
	Blue(63)	0	0	0	0	0	0	0	0	0	0	0	0	1	1	1	1	1	1

Each basic color can be displayed in 64 gray scales from 6 bit data signals. With the combination of total 18 bit data signals, the 262,144-color display can be achieved on the screen.

JAN Product Specification

	Model: GWTOC1SN9G1E0	Rev. No.	Issued Date.	Page.
		A	JUL. 13, 09	20 / 27

7. Test

No change on display and in operation under the following test condition.

Condition: Unless otherwise specified, tests will be conducted under the following condition.

Temperature: 20±5°C.

Humidity: 65±5%RH.

Tests will be not conducted under functioning state.

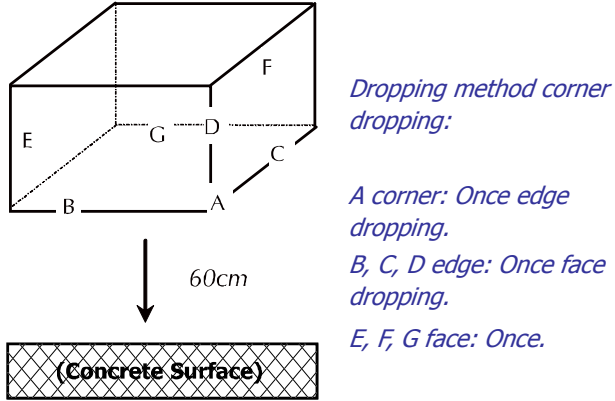
No.	Parameter	Condition	Notes
1	High Temperature Operating	60°C±2°C, 120hrs (Operation state).	
2	Low Temperature Operating	-10°C±2°C, 120hrs (Operation state).	1
3	High Temperature Storage	70°C±2°C, 120hrs.	2
4	Low Temperature Storage	-20°C±2°C, 120hrs.	1,2
5	Damp Proof Test	40°C±2°C, 90~95%, 120hrs.	1,2
6	Vibration Test	Total fixed amplitude: 1.5mm. Vibration Frequency: 10~55Hz. One cycle 60 seconds to 3 direction of X, Y, Z each 15 minutes.	3
7.	Shock Test	To be measured after dropping from 60cm high on the concrete surface in packing state.  <p style="margin-left: 20px;"><i>Dropping method corner dropping:</i></p> <p style="margin-left: 20px;"><i>A corner: Once edge dropping.</i></p> <p style="margin-left: 20px;"><i>B, C, D edge: Once face dropping.</i></p> <p style="margin-left: 20px;"><i>E, F, G face: Once.</i></p>	

- Notes:
1. No dew condensation to be observed.
 2. The function test shall be conducted after 4 hours storage at the normal temperature and humidity after removed from the test chamber.
 3. Vibration test will be conducted to the product itself without putting I in a container.

JAN Product Specification

	Model: GWTOC1SN9G1E0	Rev. No.	Issued Date.	Page.
		A	JUL. 13, 09	21 / 27

8. Appearance

8.1 Inspection

The distance between the eyes and the sample shall be more than 30cm. All directions for inspecting the sample should be within 45° against perpendicular line.

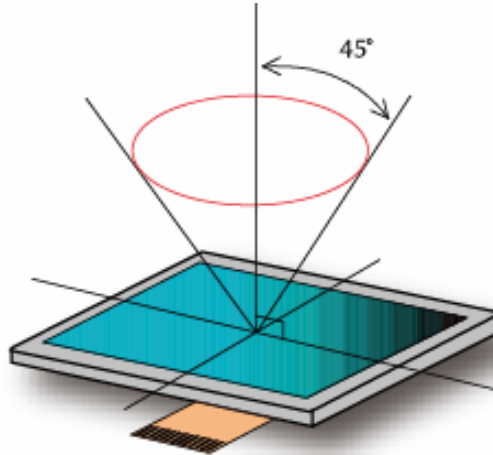

Definition of Applicable Zones

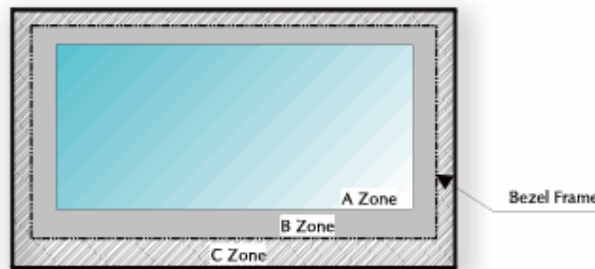

A Zone : Active display area, B Zone : Area from outside of "A Zone" to validity viewing area

C Zone : Rest parts, A Zone + B Zone = Validity viewing area

(a) Operating Inspection

The function and appearance shall be inspected in the condition of

- under 750 lx or over light Reflective Type.
- Using over Backlight unit Transflective Type, Transmissive Type

Condition of judgment

In case of no gradation display it judges by applied On/Off voltage or optimal contrast.

In case of gradation display it judges by contrast that the bad point is able to confirm best.

(b) Appearance Inspection

The appearance shall be inspected in the condition of

- under 500 lx or over light Reflective Type.
- Using over Backlight unit Transflective Type, Transmissive Type

(c) Inspection Environment

Inspection environment it carried out with 250 lx or less in principles.

JAN Product Specification

	Model: GWTOC1SN9G1E0	Rev. No.	Issued Date.	Page.
		A	JUL. 13, 09	22 / 27

9. Precautions





9.1 Operation

Burn-in sometimes happens when the same character was displayed at along time. Therefore, to prevent Burn-in, it is recommended to set up a Screen-saver function.

9.2 Safety



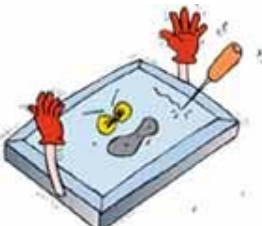

The liquid crystal in the LCD is poisonous, DO NOT put it in your mouth. If the liquid crystal touches your skin or clothes, wash it off immediately using soap and water.

9.3 Handling

	<p>a. The LCD module shall be installed flat, without twisting or bending.</p> <p>b. COF or FPC has narrow pattern width, so easily become open circuit by external force. DO NOT apply pressure to COF or FPC especially in bending area.</p>
	<p>c. To avoid damage in appearance or malfunction, DO NOT subject the module to mechanical shock or to excessive force on its surface.</p>
	<p>d. The polarizer attached to the display is very easy to damage, handle it with care to avoid scratching.</p>
	<p>e. To avoid contamination on the display surface, DO NOT touch the display surface with bare hands.</p> <p>f. Provide a space so that the LCD module does not come into contact with other components.</p>
	<p>g. To protect the LCD panel from external pressure, put covering glass (acrylic board or similar board) to keep appropriate space between them.</p>

JAN Product Specification

	Model: GWTOC1SN9G1E0	Rev. No.	Issued Date. <small>www.DataSheet4U.com</small>	Page.
		A	JUL. 13, 09	23 / 27

	h. Be careful for condensation at sudden temperature change. Condensation makes damage to polarizer or electrical contacted parts. And after fading condensation, smear or spot will occur.
	i. Property of semiconductor devices may be affected when they are exposed to light possibly resulting in malfunctioning of the ICs. To prevent such malfunctioning of the ICs, your design and mounting layout done are so that the IC is not exposed to light in actual use.
	j. Strong light exposure causes degradation of color filter. It may not recover
	k. DO NOT contact with water to avoid Metal corrosion. l. When it is not in use, the screen must be turned off or the pattern must be frequently changed by a screen saver. If it displays the same pattern for a long period of time, brightness down/image sticking may develop due to the LCD structure.
	m. Never disassemble LCD product under any circumstances. If unqualified operators or users assemble the product after disassembling it, it may not function or its operation may be seriously affected.

JAN Product Specification

	Model: GWTOC1SN9G1E0	Rev. No.	Issued Date.	Page.
		A	JUL. 13, 09	24 / 27

9.4 Static electricity

Since a module is composed of electronic circuits, it is not strong to electrostatic discharge.

	<ol style="list-style-type: none"> a. The LCD module shall be installed flat, without twisting or bending. Ground soldering iron tips, tools and testers when they operate. b. Ground your body when handling the products. c. DO NOT apply voltage to the input terminal without applying power supply. d. DO NOT apply voltage that exceeds the absolute maximum rating. e. Store the products in an anti-electrostatic container. f. Peel off protect tape, attached to polarizer, slowly to minimize ESD damage.
---	--

9.5 Storage

	<p>Store the products in a dark place at +5 ~ +25 degree C, low humidity (50%RH or less).</p> <p>DO NOT store the products in an atmosphere containing organic solvents or corrosive gases.</p>
--	---

9.6 Cleaning

	<ol style="list-style-type: none"> a. DO NOT wipe the polarizer with dry cloth, as it might cause scratch. b. Wipe the polarizer with a soft cloth soaked with petroleum IPA, other chemical might damage.
---	--

9.7 Waste

	<p>When dispose of LCD module, manage it at the production waste according to the relevant laws and regulations.</p>
---	--

JAN Product Specification

	Model: GWTOC1SN9G1E0	Rev. No.	Issued Date.	Page.
		A	JUL. 13, 09	25 / 27

10. Warranty

This product has been manufactured to your company's specifications as a part for use in your company's general electronic products. It is guaranteed to perform according to delivery specifications. For any other use apart from general electronic equipment, we cannot take responsibility if the product is used in medical devices, nuclear power control equipment, aerospace equipment, fire and security systems, or any other applications in which there is a direct risk to human life and where extremely high levels of reliability are required. If the product is to be used in any of the above applications, we will need to enter into a separate product liability agreement.

- 1 We cannot accept responsibility for any defect, which may arise from additional manufacturing of the product (including disassembly and reassembly), after product delivery.
- 2 We cannot accept responsibility for any defect, which may arise after the application of strong external force to the product.
- 3 We cannot accept responsibility for any defect, which may arise due to the application of static electricity after the product has passed your company's acceptance inspection procedures.
- 4 We cannot accept responsibility for industrial property, which may arise through the use of your product, with exception to those issues relating directly to the structure or method of manufacturing of our product. SGD-origin longer than one year from SGD production.

JAN Product Specification



Model: GWTOC1SN9G1E0

Rev. No.

Issued Date.

Page.

A

JUL. 13, 09

26 / 27

11. Dimensional Outlines

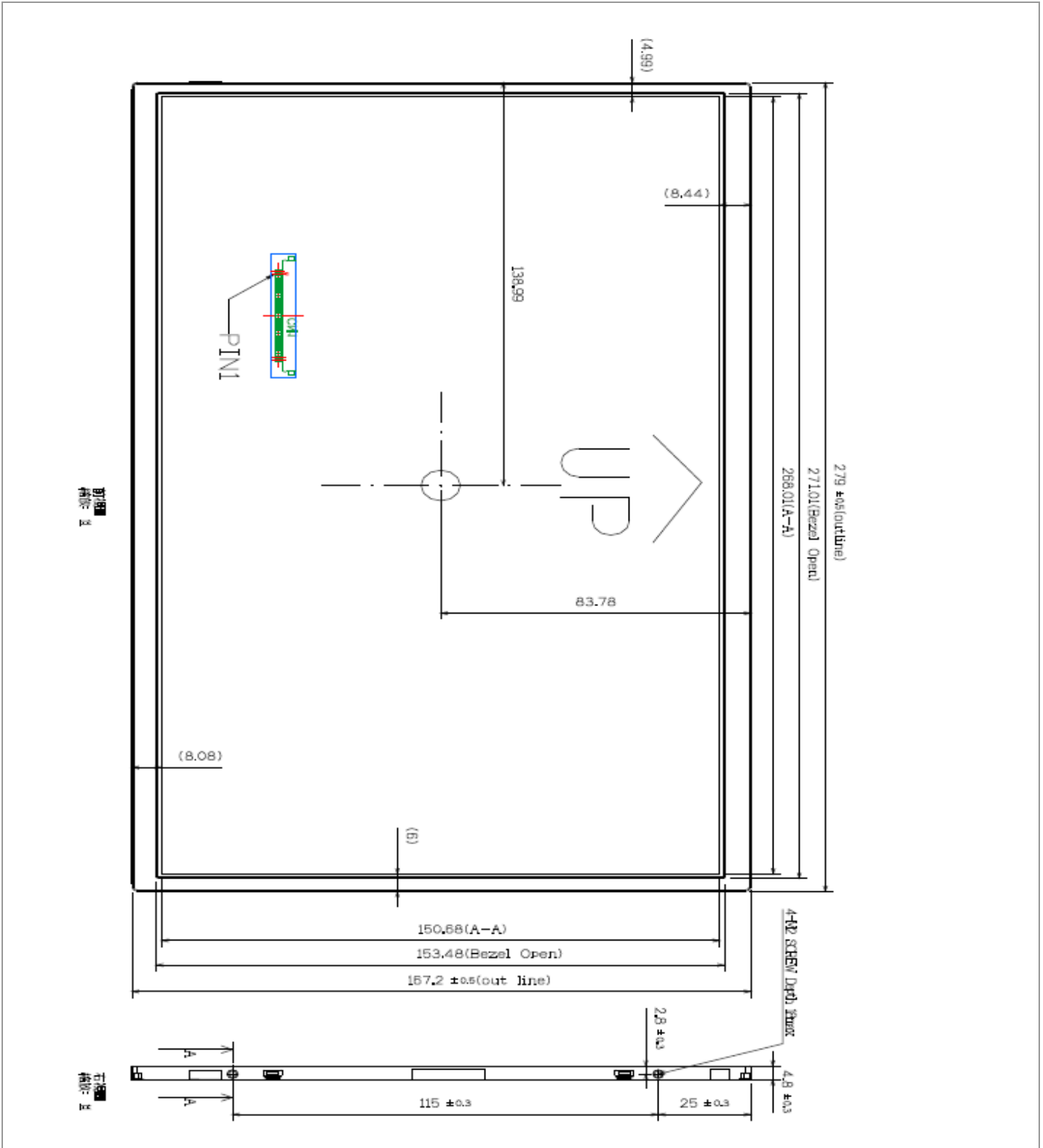

JAN Product Specification



Model: GWTOC1SN9G1E0

Rev. No.

Issued Date.

Page.

A

JUL. 13, 09

27 / 27

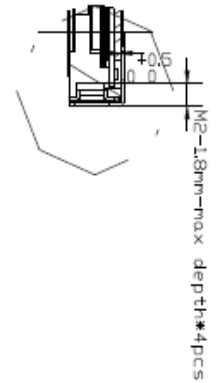
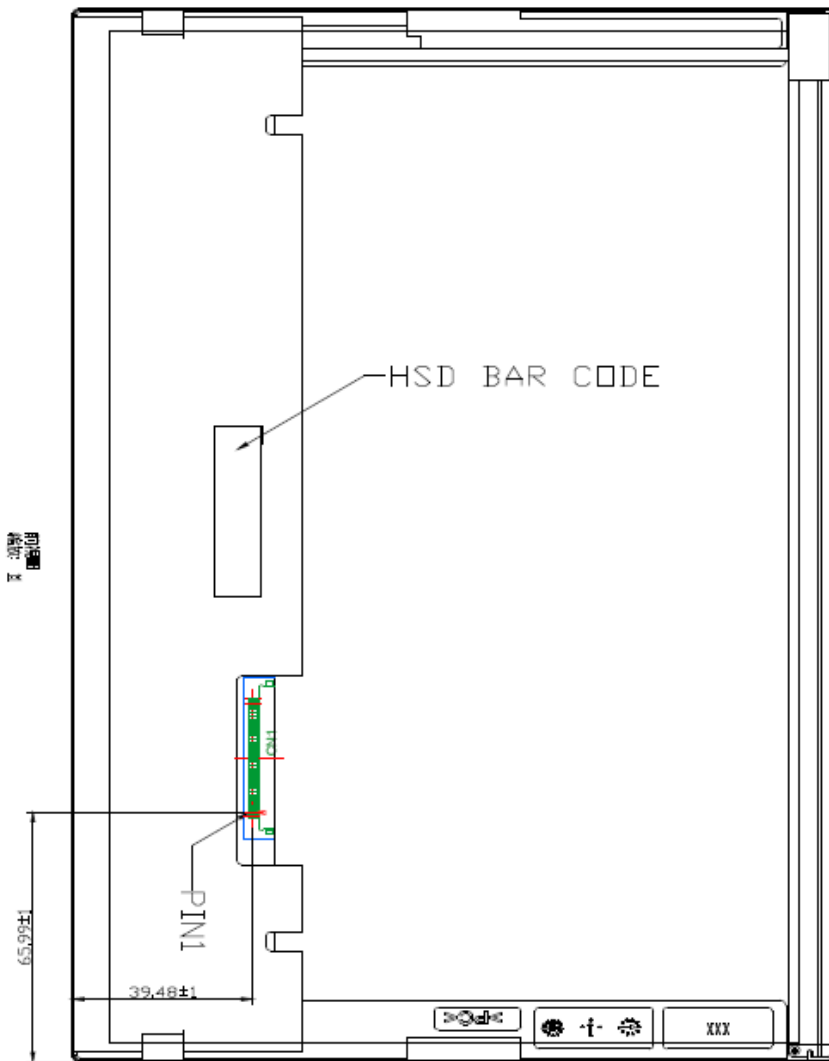

CN1:FI-XB30SL-HF10(JAE or equivalent)