

Version : 0.2

液晶之友 电话: 020-33819057
Http://www.lcdfriends.com

TECHNICAL SPECIFICATION

MODEL NO. : PA079DS1

Customer's Confirmation

Customer Name _____

Date _____

By _____

PVI's Confirmation

Confirmed By _____

Prepared By _____

PRIME VIEW INTERNATIONAL CO.,LTD.
3,LI SHIN RD. 1,SCIENCE-BASED INDUSTRIAL
PARK,HSINCHU,TAIWAN,R.O.C.
<http://www.pvi.com.tw>

Date : Mar. 13,2001

This technical specification is subject to change without notice.

Please return 1 copy with your signature on this page for approval.

TECHNICAL SPECIFICATION

CONTENTS

<i>NO.</i>	<i>ITEM</i>	<i>PAGE</i>
-	Cover(PA079DS1)	1
-	Contents	2
1	Application	3
2	Features	3
3	Mechanical Specifications	3
4	Mechanical Drawing of TFT-LCD module	4
5	Input / Output Terminals	5
6	Absolute Maximum Ratings	8
7	Electrical Characteristics	8
8	Optical Characteristics	17
9	Reliability Test	20
10	Block Diagram	21
11	Packing	22
-	Revision History	23

0. Application

This technical specification applies to 7.9" color TFT-LCD module1,PA079DS1.The applications of the panel are car TV, portable DVD , Video Display, multimedia applications and others AV system.

2. Features

- . Compatible with NTSC & PAL system
- . Pixel in stripe configuration
- . Slim and compact
- . Dual lamp design to make high picture brightness
- . Image Reversion : Up/Down and Left/Right

3. Mechanical Specifications

Parameter	Specifications	Unit
Screen Size	7.9 (diagonal)	inch
Display Format	1440(H)× 234(V)	dot
Active Area	161.28 (H)× 117.936 (V)	mm
Dot Pitch	0.112(H)× 0.504 (V)	mm
Pixel Configuration	Stripe	
Outline Dimension	191.4 (W)× 144.6 (H)× 11.5 (D)(Typ.)	mm
Surface treatment	Anti-glare and hard coating	
Weight	365±10	g

4. Mechanical Drawing of TFT-LCD Module

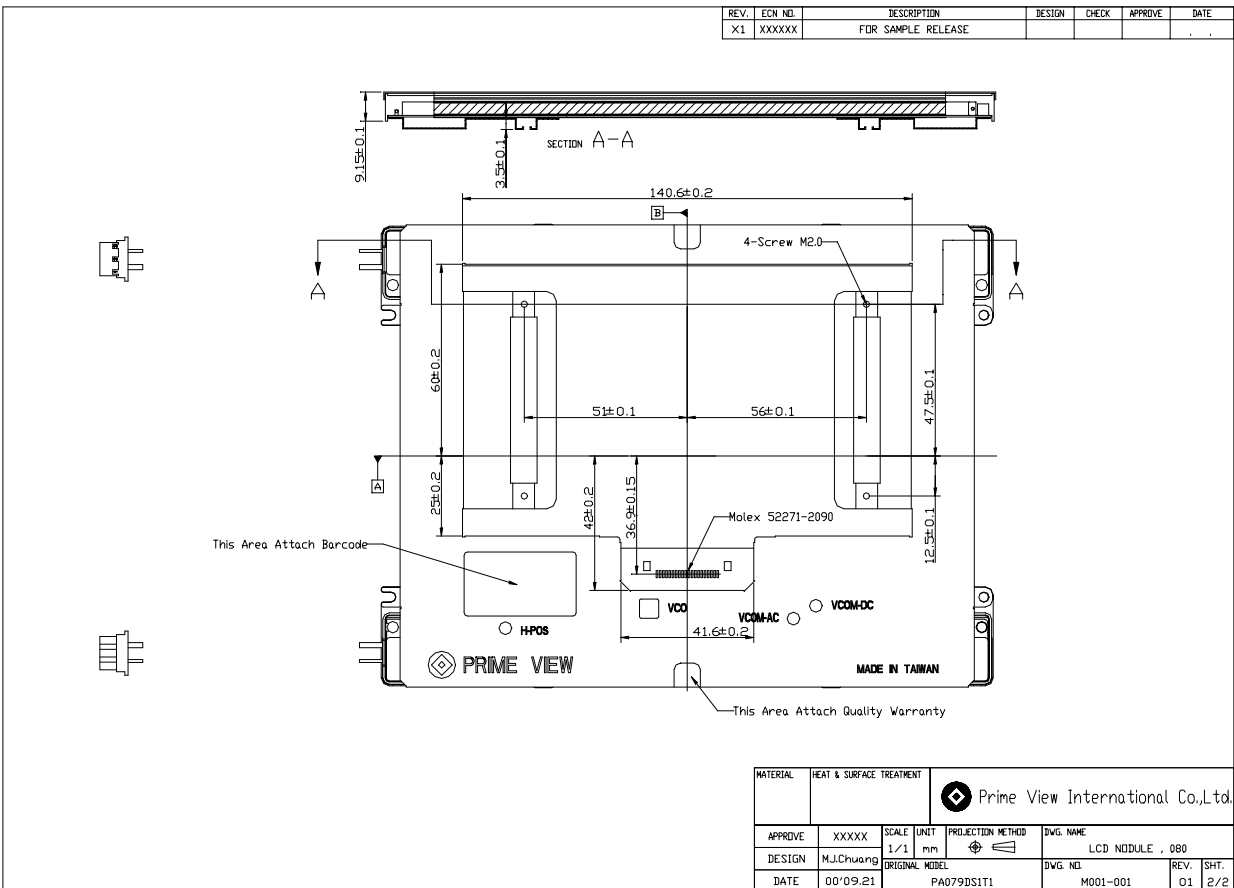
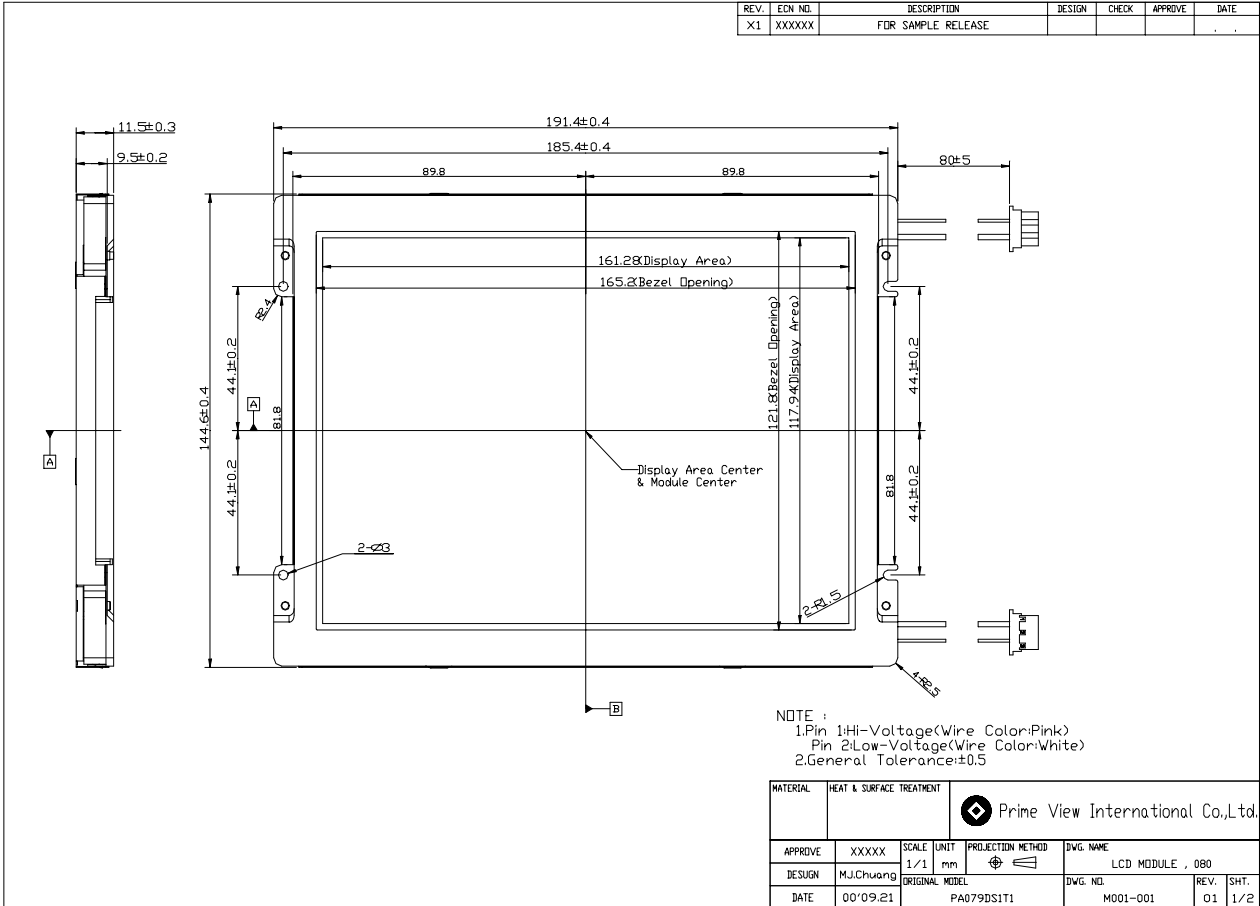

5. Input / Output Terminals
5-1) TFT-LCD Panel Driving

Pin No	Symbol	I/O	Description	Remark
1	$\overline{\text{HSY}}$	I/O	Horizontal Sync. Input / Output	Note 5-1
2	FRP	O	Video Polarity Alternating Signal	
3	CSY	I	Composite Sync. Signal	Note 5-1
4	V _{GH}	I	Supply Voltage for Gate Driver (Hi level)	Note 5-2
5	V _{GL}	I	Supply Voltage for Gate Driver (Low level)	Note 5-3
6	V _B	I	Video Signal (Blue)	
7	V _R	I	Video Signal (Red)	
8	V _G	I	Video Signal (Green)	
9	GND	I	Ground	
10	V _{DD}	I	Supply voltage for Controller	Note 5-4
11	V _{CC}	I	Supply voltage for source driver	Note 5-5
12	GND	I	Ground	
13	CKC	I	Control pin for select I/O signal	Note 5-1
14	$\overline{\text{VS}}\overline{\text{Y}}$	I/O	Vertical Sync. Input/ Output	Note 5-1
15	PSI	O	Synchronize Pulse for Decoder	
16	PSC	O	Synchronize Pulse for DC-DC Converter	
17	NC	-	No Connection	
18	UD	I	UP/DOWN Control	Note 5-7
19	RL	I	Right/Left Shift Control	Note 5-6
20	NP	I	NTSC/PAL Input	Note 5-8

Note 5-1 : Pin 13 (CKC) can select the function for Pin 1 ($\overline{\text{HSY}}$), Pin 3 (CSY), and Pin 14 ($\overline{\text{VS}}\overline{\text{Y}}$).

Pin 13 (CKC)	Pin 1 ($\overline{\text{HSY}}$)	Pin 3 (CSY)	Pin 14 ($\overline{\text{VS}}\overline{\text{Y}}$)
Hi	$\overline{\text{HSY}}$ Output	CSY Input	$\overline{\text{VS}}\overline{\text{Y}}$ Output
Low	External Horizontal Sync Input	External Clock Input	External Vertical Sync Input

Note 5-1-1: CKC= High:

- If CKC=1, the phase lock loop (PLL) is adopted in the LCD module.
- Inputs CSY, the controller of LCD module will separate the Vertical Sync and Horizontal Sync from CSY.
- Output Horizontal Sync ($\overline{\text{HSY}}$, Pin 1) and Vertical Sync ($\overline{\text{VS}}\overline{\text{Y}}$, Pin 14)..

d. The internal detect will detect Vertical Sync to reset the vertical counter.

Note 5-1-2: CKC= Low (VGA mode)

- a. If CKC=0, the phase lock loop (PLL) is not adopted in the LCD module.
- b. If CKC=0, the external clock input frequency of Pin 3 is 25.175 MHz.
- c. Input external Horizontal Sync (Pin 1) to synchronize the LCD module. External Horizontal Sync and External Vertical Sync input pulse can be high going or low going.

0. The cycle of external Horizontal Sync input is 31.8 μ s. The cycle of external Vertical Sync input is 525H.

Note 5-1-3: If there is any question about CKC=0, please contact PVI.

Note 5-2 : V_{GH} TYP. = +17V

Note 5-3 : V_{GL} TYP. = -15V

Note 5-4 : V_{DD} TYP. = +5V

Note 5-5 : V_{CC} TYP. = +5V

Note 5-6 : Low (0V) for shift Right; Input Hi (+5.0V) for inverse (shift Left).

Note 5-7 : Hi (+5.0V) for DOWN; Low (0V) for UP.

Note 5-8 : PAL= LOW(0V),NTSC= Hi(+5.0V)

	Low	High
Note5-6	Right	Left
Note5-7	Down	Up
Note5-8	PAL	NTSC

5-2) Backlight driving

Pin No	Symbol	Description	Remark
1	VL1	Input terminal (Hi voltage side)	Wire color: pink
2	NC	NO Connection	
3	VL2	Input terminal (Low voltage side)	Wire color: white Note 5-9

Note 5-9 : Low voltage side of backlight inverter connects with Ground of inverter circuits.

5-3) Input / Output Connector**0. LCD Module Connector**

6200-20P (Molex)

FFC Down Connector

20 Pins

Pitch : 1.0 mm

B) Backlight Connector

JST BHR-03VS-1

Pin No. : 3

Pitch : 4 mm

Pink: High Voltage

White: Low Voltage

6. Absolute Maximum Ratings:

GND = 0 V , Ta = 25 °C

Parameter		Symbol	MIN.	MAX.	Unit	Remark	
Supply Voltage For Source Driver		V _{CC}	-0.5	7	V		
		V _{DD}	-0.5	7	V		
Supply Voltage For Gate Driver		V _{GH} - V _{GL}	-0.3	40	V		
		H Level	V _{GH}	0	40	V	
		L Level	V _{GL}	-20	0	V	
Analog Signal Input Level		V _R ,V _G ,V _B	-0.3	7.0	V		
Digital Input Signals			-0.3	5.5	V	Note 6-1	
Digital Output Signals			-0.3	5.5	V	Note 6-2	
Storage Temperature			-30	+80	°C		
Operation Temperature			-20	+70	°C		

 Note 6-1 : $\overline{\text{HSY}}$, $\overline{\text{CSY}}$, $\overline{\text{VSY}}$, $\overline{\text{CKC}}$,

 Note 6-2 : $\overline{\text{HSY}}$, $\overline{\text{VSY}}$, $\overline{\text{PSI}}$, $\overline{\text{PSC}}$
7. Electrical Characteristics
7-1) Recommended Operating Conditions:
0. Driving for TFT-LCD Panel

GND = 0V , Ta = 25 °C

Parameter		Symbol	MIN.	Typ	MAX	Unit	Remark
Supply Voltage For Source Driver		Analog	V _{CC}	4.5	5.0	5.5	V
		Logic	V _{DD}	4.5	5.0	5.5	V
Supply Voltage For Gate Driver		H level	V _{GH}	+15	+17	+19	V
		L level	V _{GL}	-16	-15	-14	V
Supply Voltage For controller			V _{DD}	4.5	5.0	5.5	V
Analog Signal input Level		Amplitude		0.3		V _{CC} -0.3	V
Digital input voltage		H level	V _{IH}	0.7 V _{DD}	-	V _{DD}	V
		L level	V _{IL}	-0.3	-	0.3 V _{DD}	V
Digital output voltage		H level	V _{OH}	0.7 V _{DD}	-	V _{DD}	V
		L level	V _{OL}	-0.3	-	0.3 V _{DD}	V

B) Driving for backlight

Ta= 25 °C

Parameter	Symbol	Min.	Typ.	Max.	Unit	Remark
Lamp voltage	V _L		400		Vrms	I _L = 6 mA
Lamp current	I _L	3.5	6	8	mA	
Lamp frequency	P _L		60		KHz	Note 7-1
Kick-off voltage(25°C)	Vs	TBD	TBD	750	Vrms	Note 7-2
Kick-off voltage(0°C)	Vs	TBD	TBD	950	Vrms	Note 7-2

Note 7-1 : The wave form of lamp driving voltage should be as closed to a perfect SIN wave as possible.

Note 7-2 : The Kick-off times ≥ 1sec

7-2) Power Consumption

Ta= 25 °C

Parameter	Symbol	Conditions	TYP.	MAX	Unit	Remark
Supply current for Gate Driver (Hi level)	I _{GH}	V _{GH} = +17V	0.15	0.2	mA	
Supply current for Gate Driver (Low level)	I _{GL}	V _{GL} = -15V	20	30	mA	
Supply current for Source Driver	I _{CC}	V _{CC} = +5V	20	30	mA	
Supply current for controller	I _{DD}	V _{DD} = +5V	20	30	mA	
LCD Panel Power Consumption			0.51		W	Note 7-3
Backlight Lamp Power Consumption			4.8		W	Note 7-4

Note 7-3 : The power consumption for backlight is not included.

Note 7-4 : Backlight lamp power consumption is calculated by I_L × V_L.

7-3) Input / Output signal timing chart

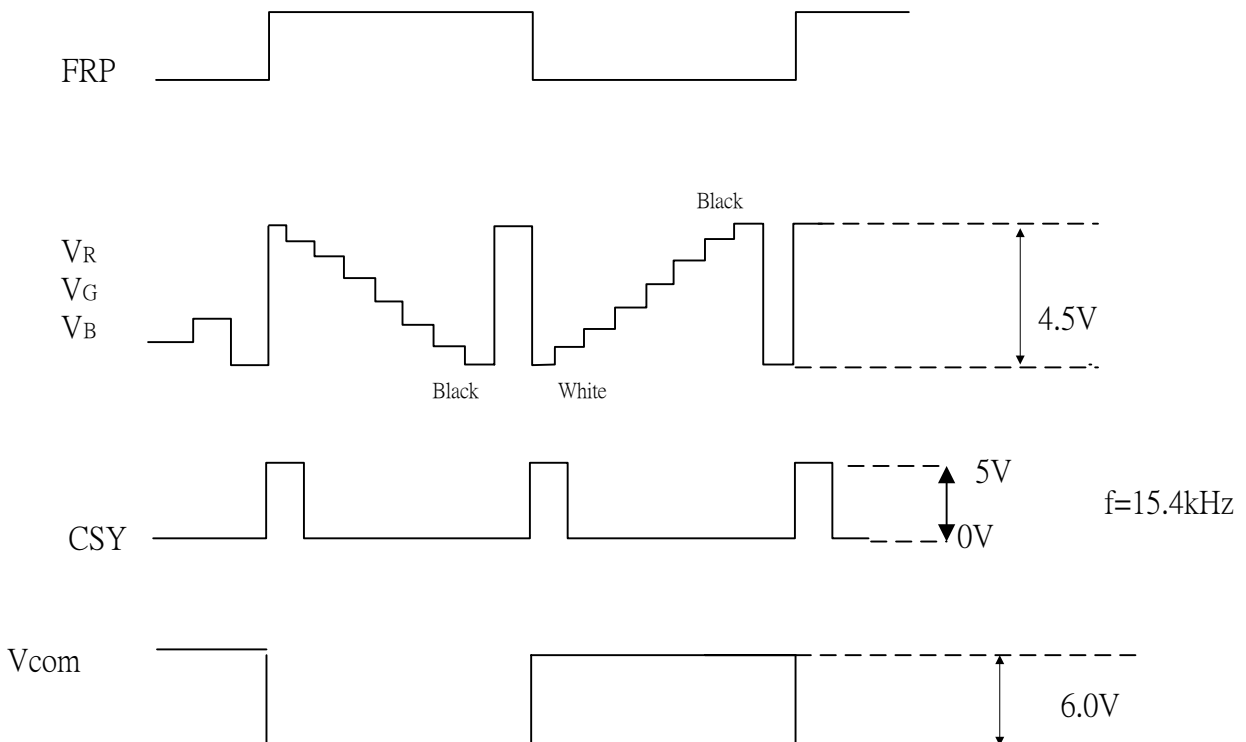

Parameter		Symbol	MIN.	TYP.	MAX.	Unit	Remarks	
Horizontal Sync. Output	Frequency	NTSC $F_{HO(N)}$	-	15.73	-	KHz		
		PAL $F_{HO(P)}$	-	15.63	-	KHz		
Pulse	Pulse Width	T_{HO}	4.4	4.7	5.0	μs		
	Phase Difference	T_{HP}	0	2	-	μs		
	Rising Time	T_{HR}	-	-	0.05	μs		
	Falling Time	T_{HF}	-	-	0.05	μs		
Vertical Sync. Output Pulse	Frequency	NTSC		$fh/262.5$				
		PAL		$fh/312.5$				
	Pulse Width	T_{VO}	-	4H	-	μs		
	Phase Difference	NTSC	$T_{VPO(N)}$	-	2H	-	μs	odd field
		PAL	$T_{VPO(P)}$	-	1H	-		
	Phase Difference	NTSC	$T_{VPE(N)}$	-	1.5H	-	μs	even field
PAL		$T_{VPE(P)}$	-	0.5H	-			

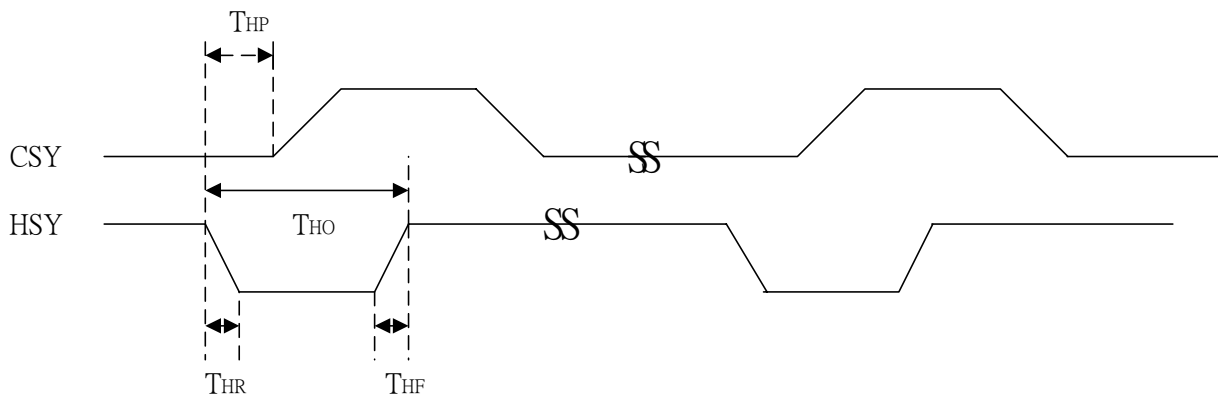

7-4) Display Time Range

A) When sync. Signal of NTSC system is applied.

a) Horizontally

11.35 ~ 61.36 μs .

b) Vertical

22 ~ 255 H

0. When sync. Signal of PAL system is applied.

a) Horizontally

11.54 ~ 61.9 μs

0. Vertical

28 ~ 300 H

0. NTSC System

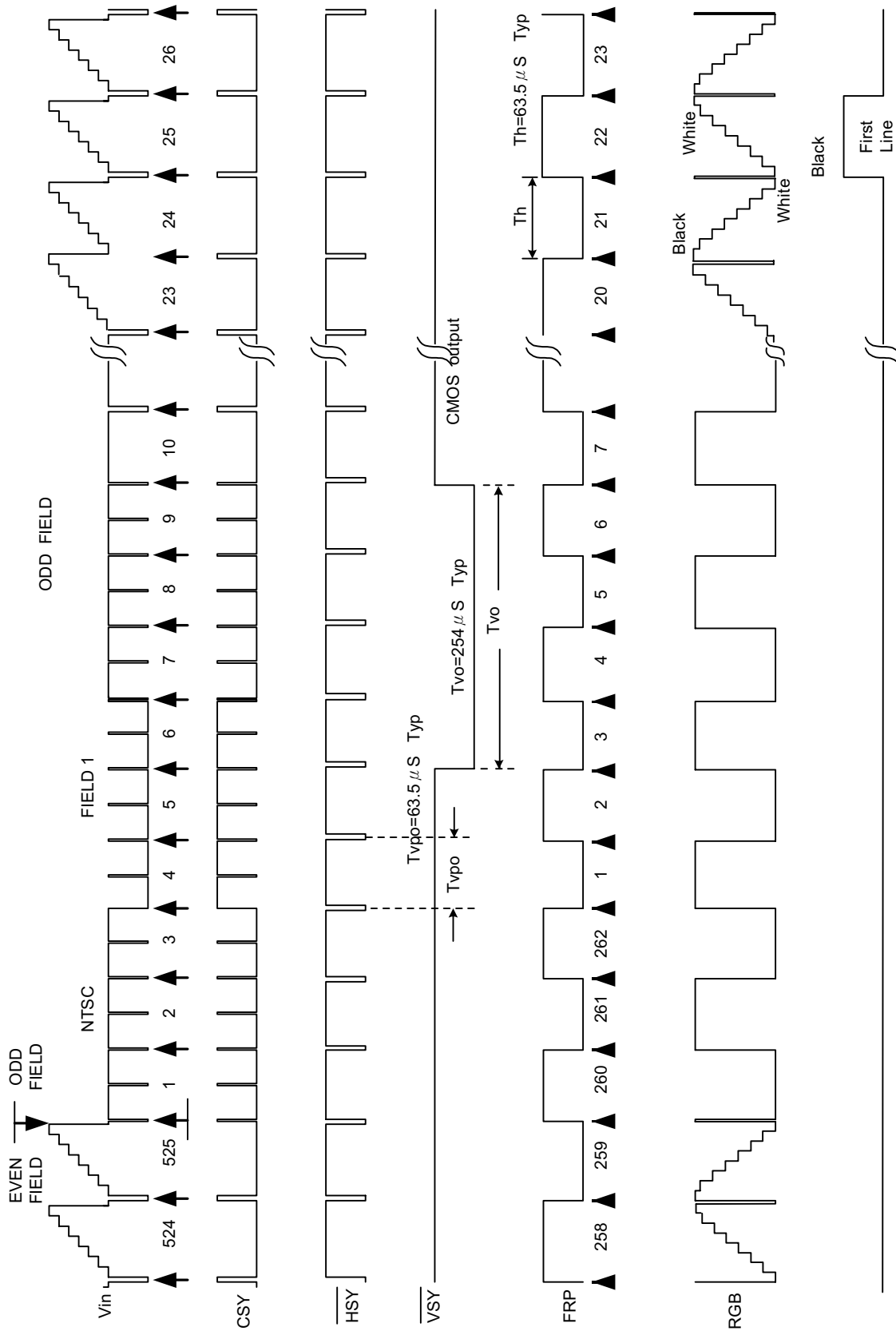

Timing chart of I/O and RGB signal

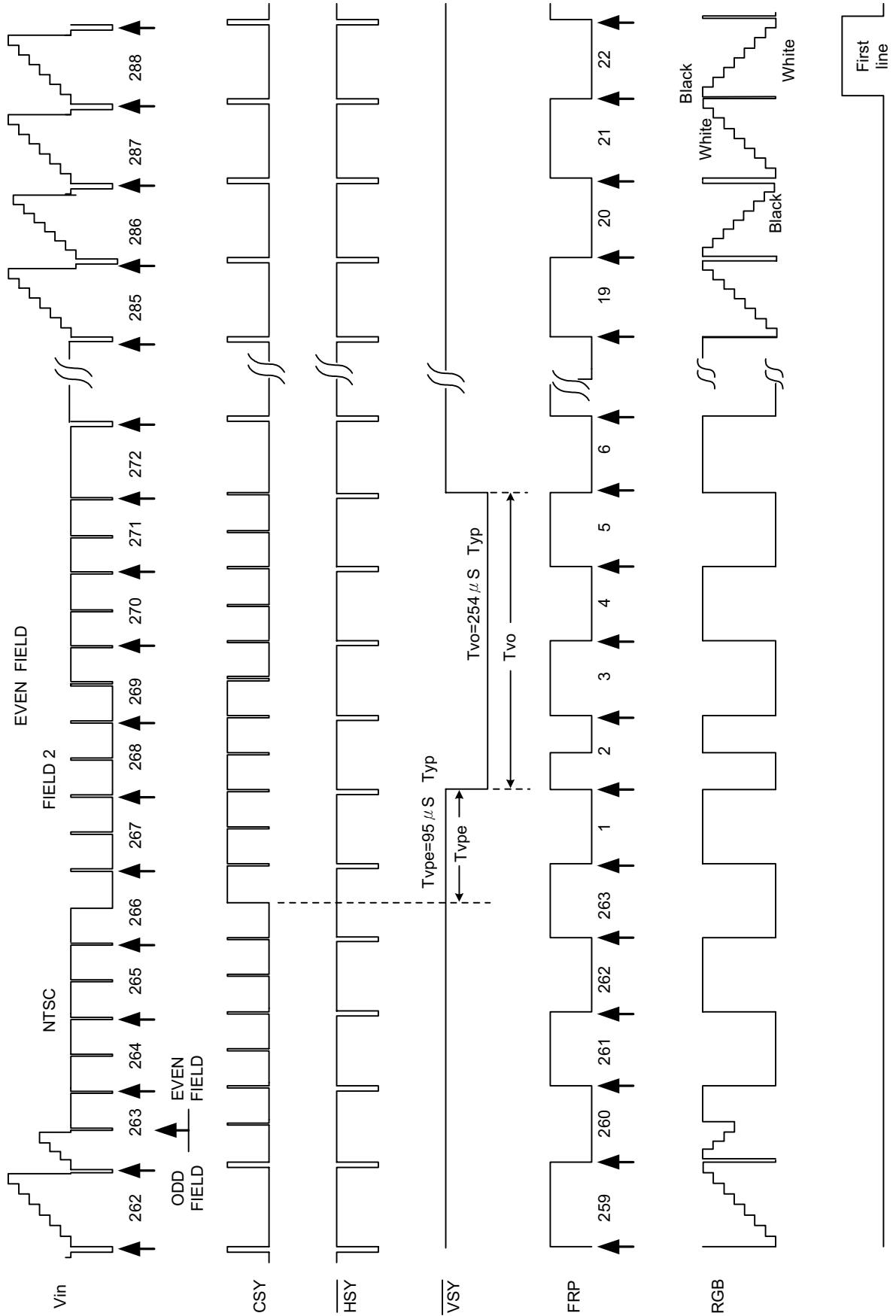

Timing chart of I/O and RGB signal

D) PAL System

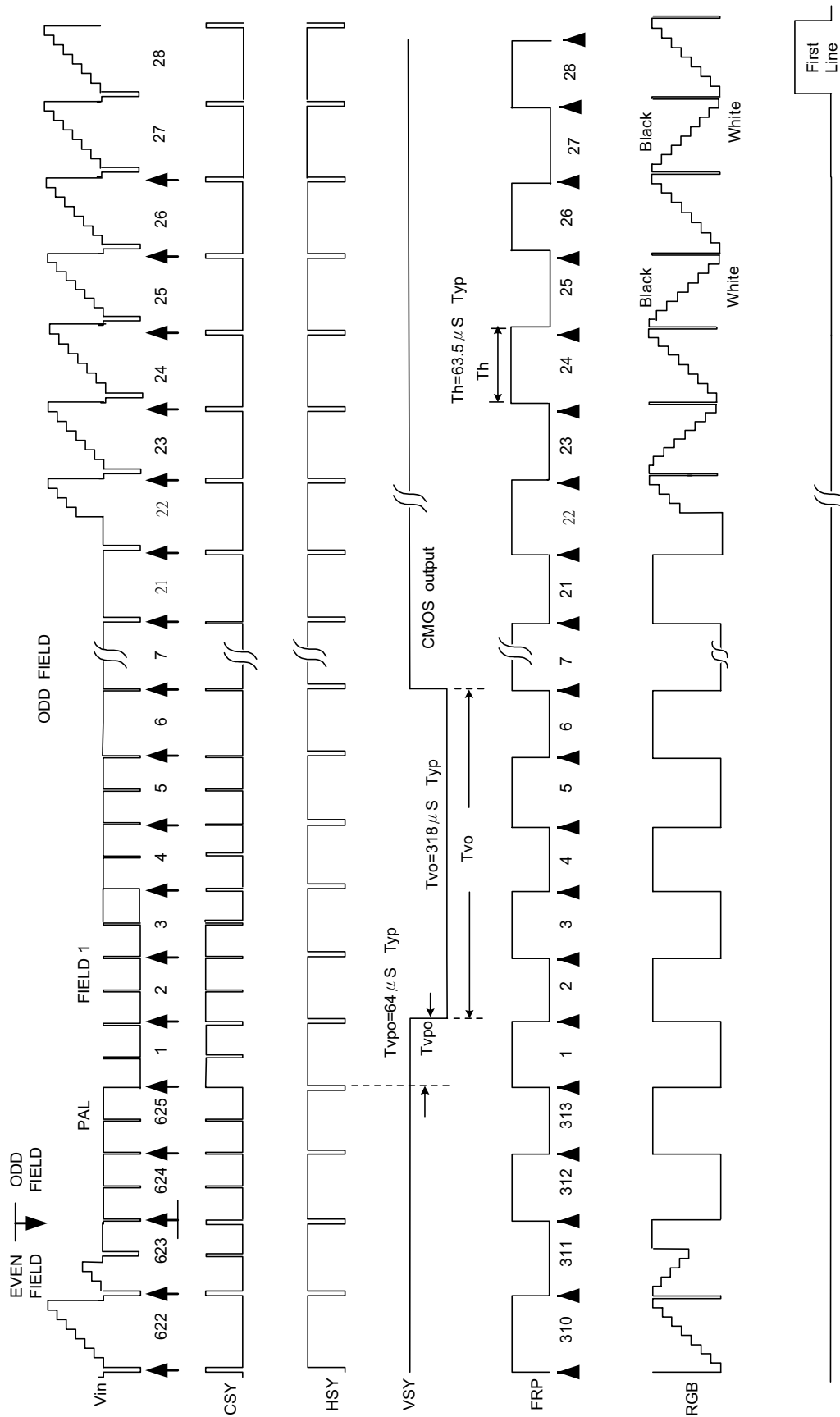

Timing chart of I/O and RGB signal

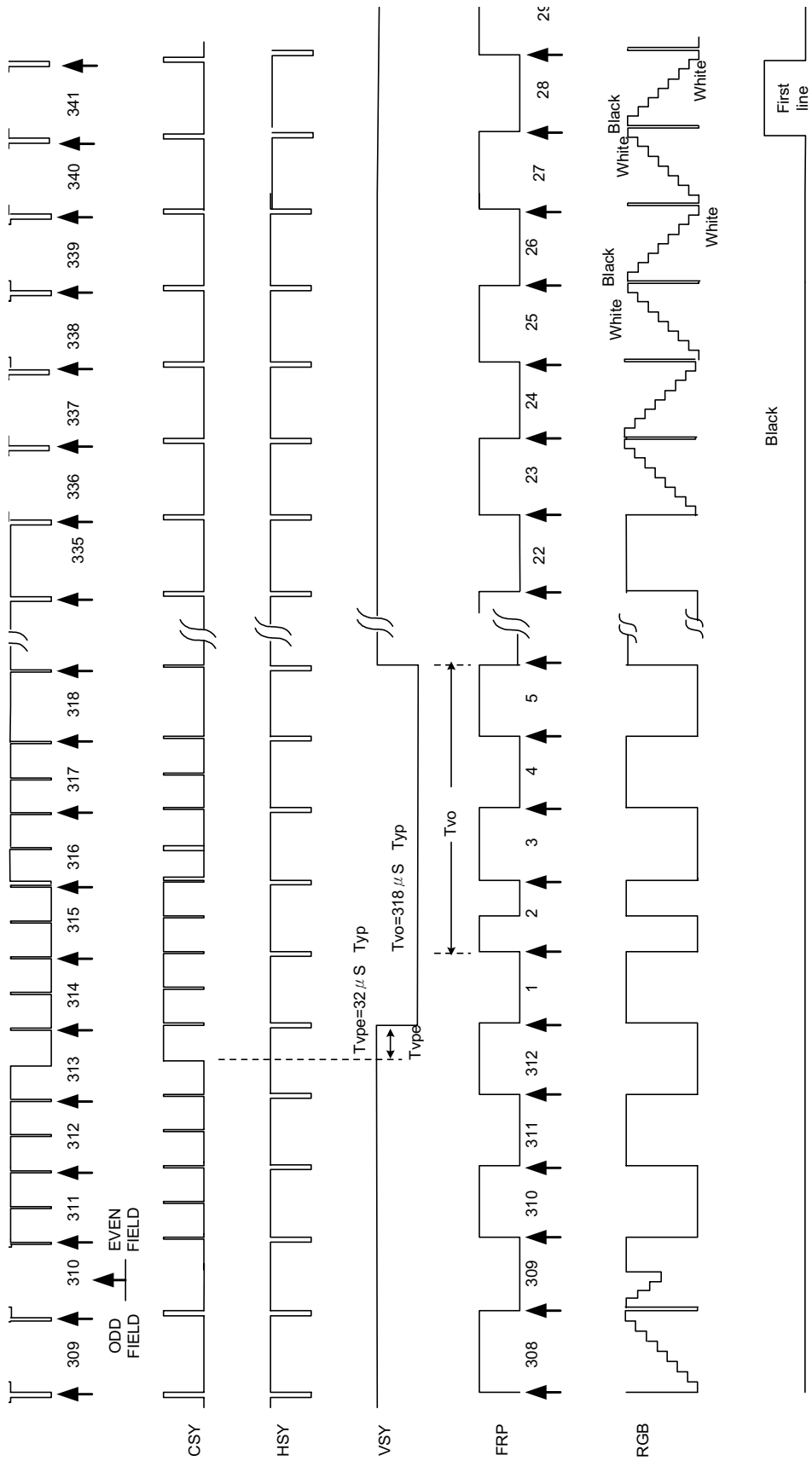

Timing chart of I/O and RGB signal

E) Display Timing

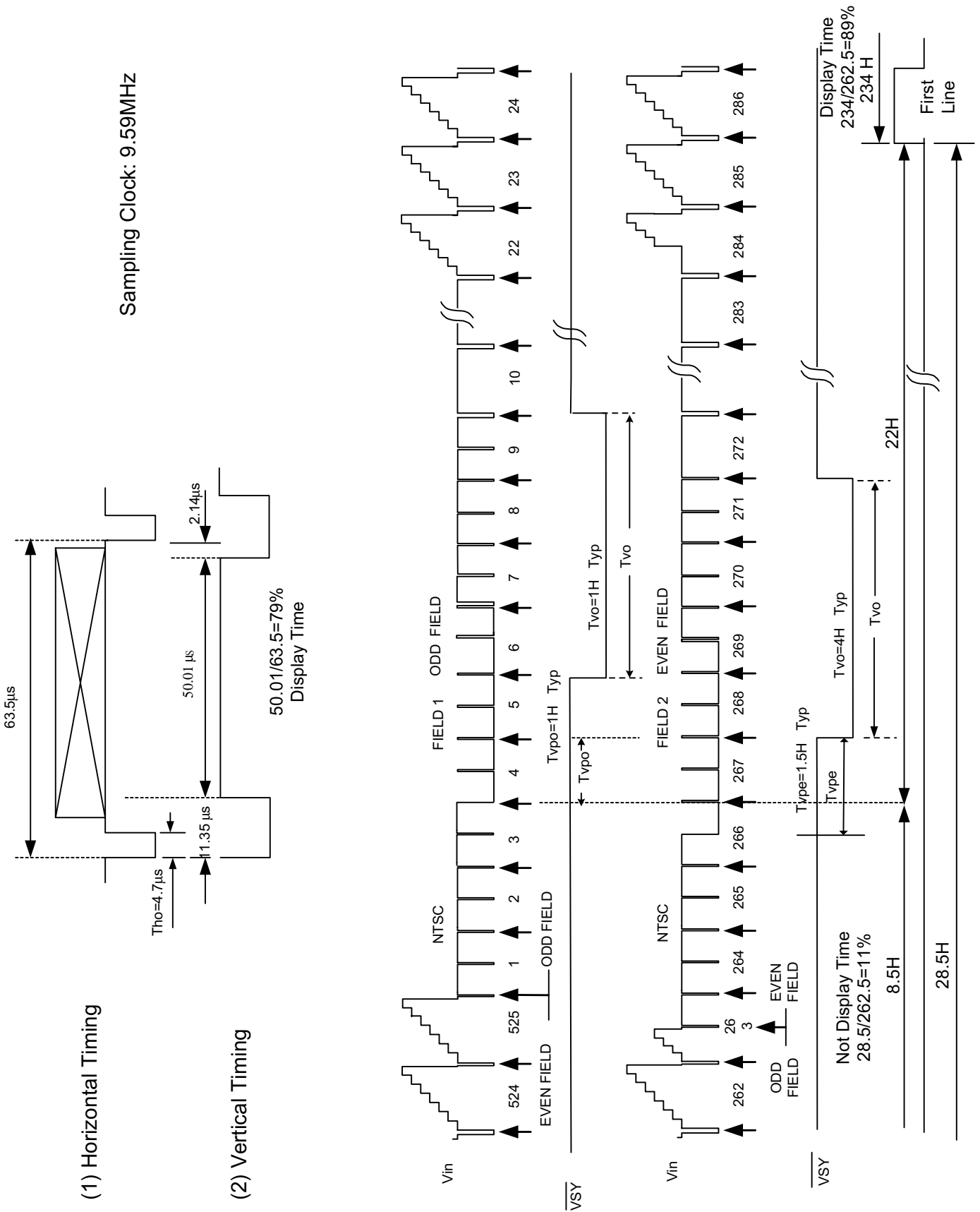

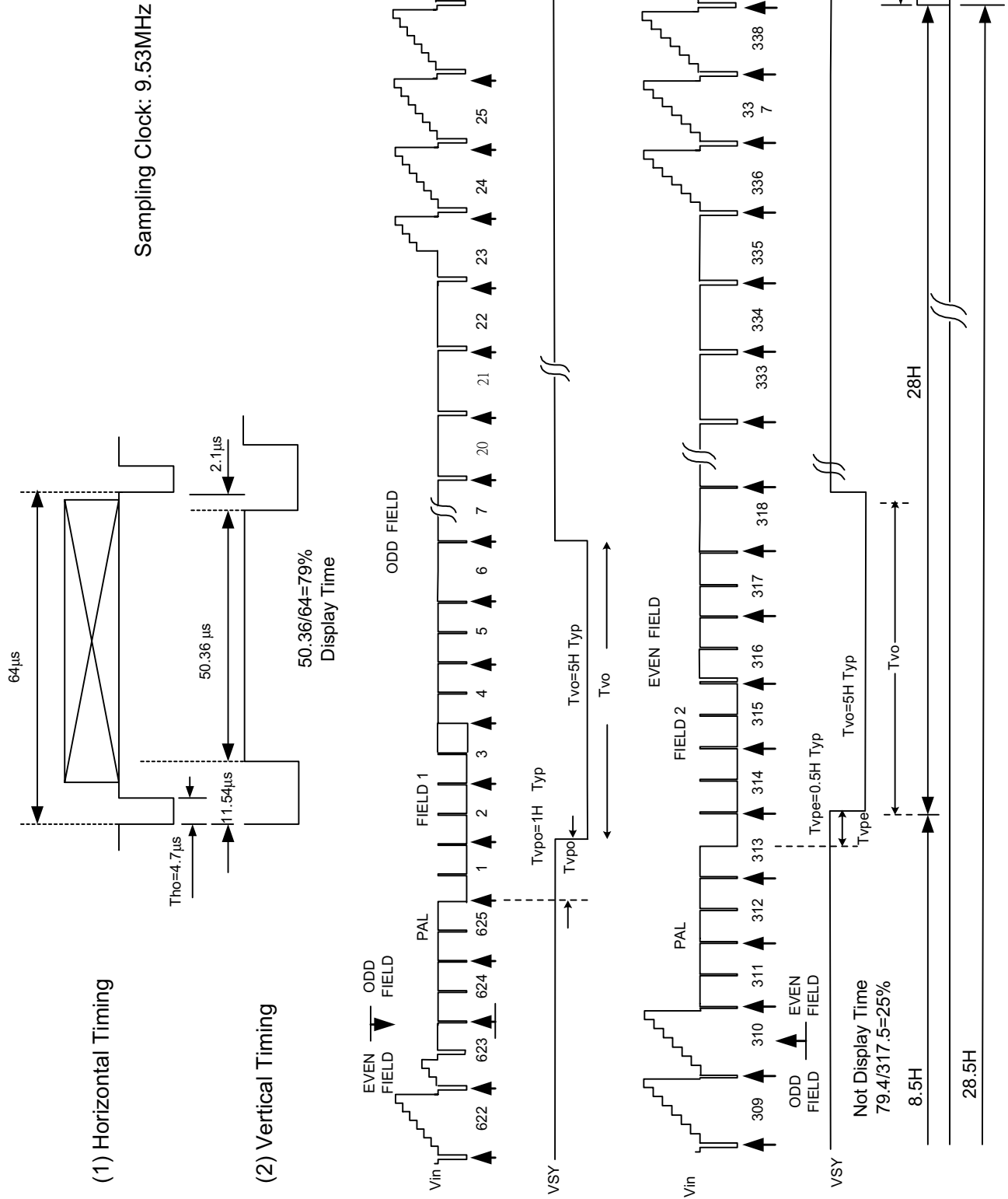

8. Optical Characteristics

8-1) Specification:

Ta = 25°C

Parameter		Symbol	Condition	MIN.	TYP.	MAX.	Unit	Remarks
Viewing Angle	Horizontal	$\theta 21, \theta 22$	$CR \geq 10$	45	55		deg	Note 8-1
	Vertical	$\theta 12$		10	15		deg	Note 8-1
		$\theta 11$		30	35		deg	Note 8-1
Contrast Ratio		CR		80	150			Note 8-2
Response time	Rise	Tr	$\theta = 0^\circ$			30	ms	Note 8-4
	Fall	Tf				50	ms	
Brightness				250	350		cd/m ²	Note 8-3
White Chromaticity	x		$\theta = 0^\circ$	0.265	0.315	0.365		Note 8-3
	y		$\theta = 0^\circ$	0.280	0.330	0.380		
Lamp Life Time +25°C				20000	25000		hr	

Note 8-1: The definitions of viewing angles

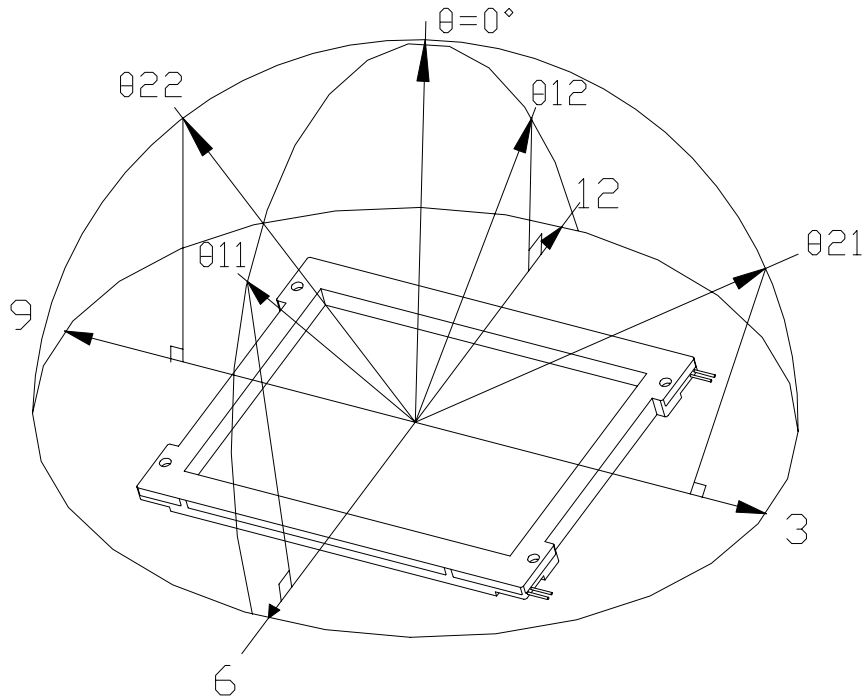

Note 8-2 : $CR = \frac{\text{Luminance when Testing point is White}}{\text{Luminance when Testing point is Black}}$

(Testing configuration see 8-2)

Contrast Ratio is measured in optimum common electrode voltage.

Note 8-3 : Topcon BM-7(fast) luminance meter 2° field of view is used in the testing (after 20~30 minutes operation).

Lamp Current 6mA

Note 8-4: The definition of response time:

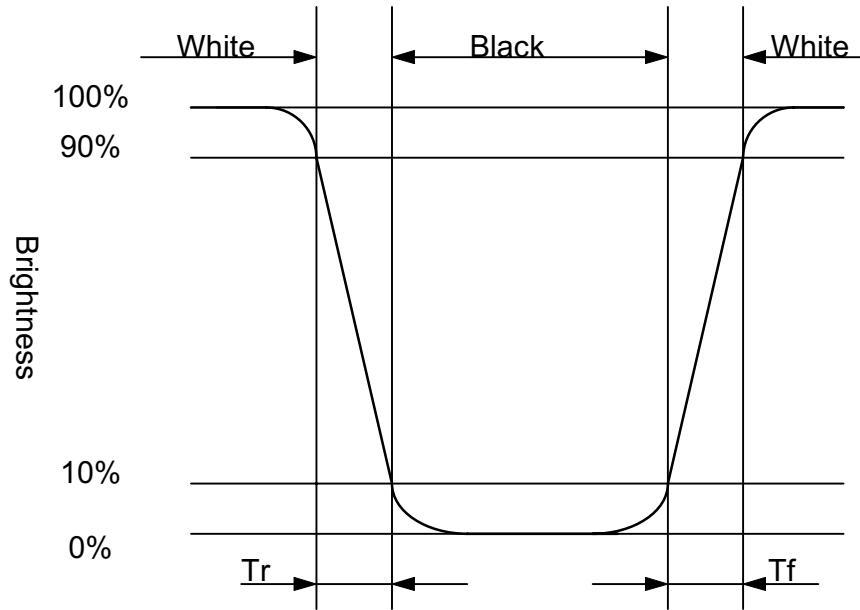

8-2) Testing configuration

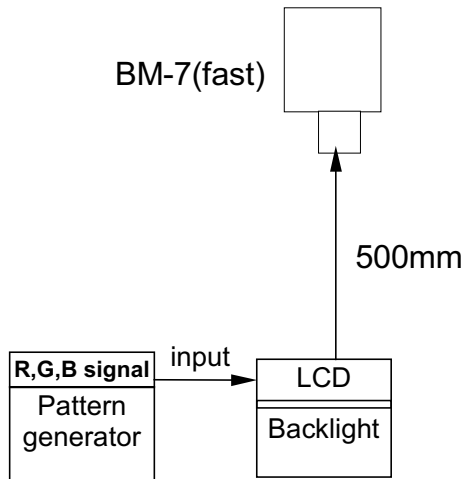

Caution: 1. Environmental illumination ≤ 1 lux
 2. Before test CR, Vcom voltage must be adjusted carefully to get the best CR.

- LCD Display Testing Point Testing Point

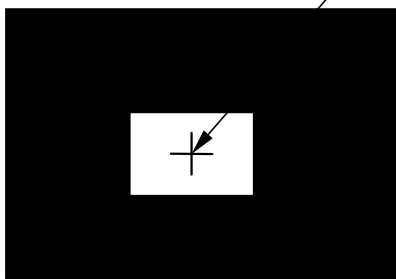

Pattern A

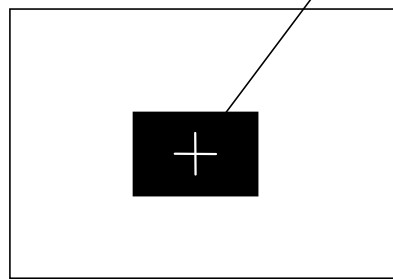

Pattern B

- R, G, B Waveform of Pattern A at Testing Point

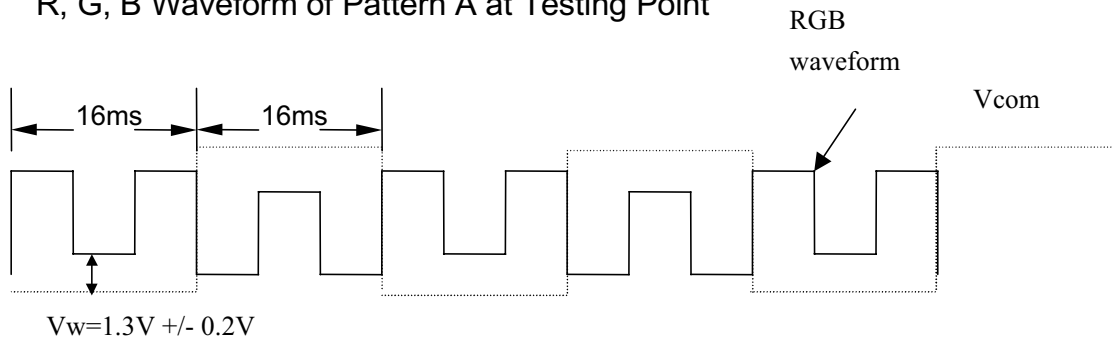

- R, G, B Waveform of Pattern B at Testing Point

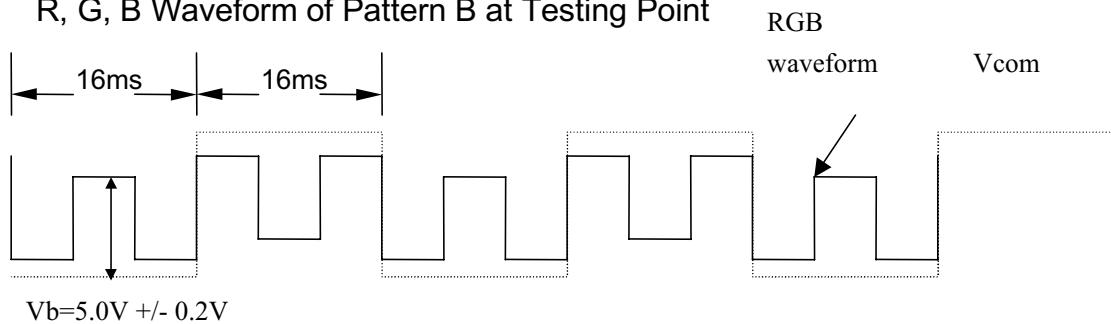

9. Reliability Test

No	Test Item	Test Condition
1	High Temperature Storage Test	Ta = +80 °C, 240 hrs
2	Low Temperature Storage Test	Ta = -30°C, 240 hrs
3	High Temperature Operation Test	Ta = +70 °C, 240 hrs
4	Low Temperature Operation Test	Ta = -20 °C, 240 hrs
5	High Temperature & High Humidity Operation Test	Ta = +60°C, 95%RH, 240 hrs
6	Thermal Cycling Test (non-operating)	-25°C → +25°C → +70°C, 200 Cycles 30 min 5min 30 min
7	Vibration Test (non-operating)	Frequency : 10 ~ 55 Hz Amplitude : 1.5 mm Sweep time: 11 mins Test Period: 6 Cycles for each direction of X, Y, Z
8	Shock Test (non-operating)	100G, 6ms Direction: ± X, ± Y, ± Z Cycle: 3 times
9	Electrostatic Discharge Test (non-operating)	150pF, 330Ω Air: ±15KV; Contact: ±8KV 10 times/point, 9 points/panel face

Ta: ambient temperature

[Criteria]

Under the display quality test conditions with normal operation state, there should be no change which may affect practical display function.

10. Block Diagram

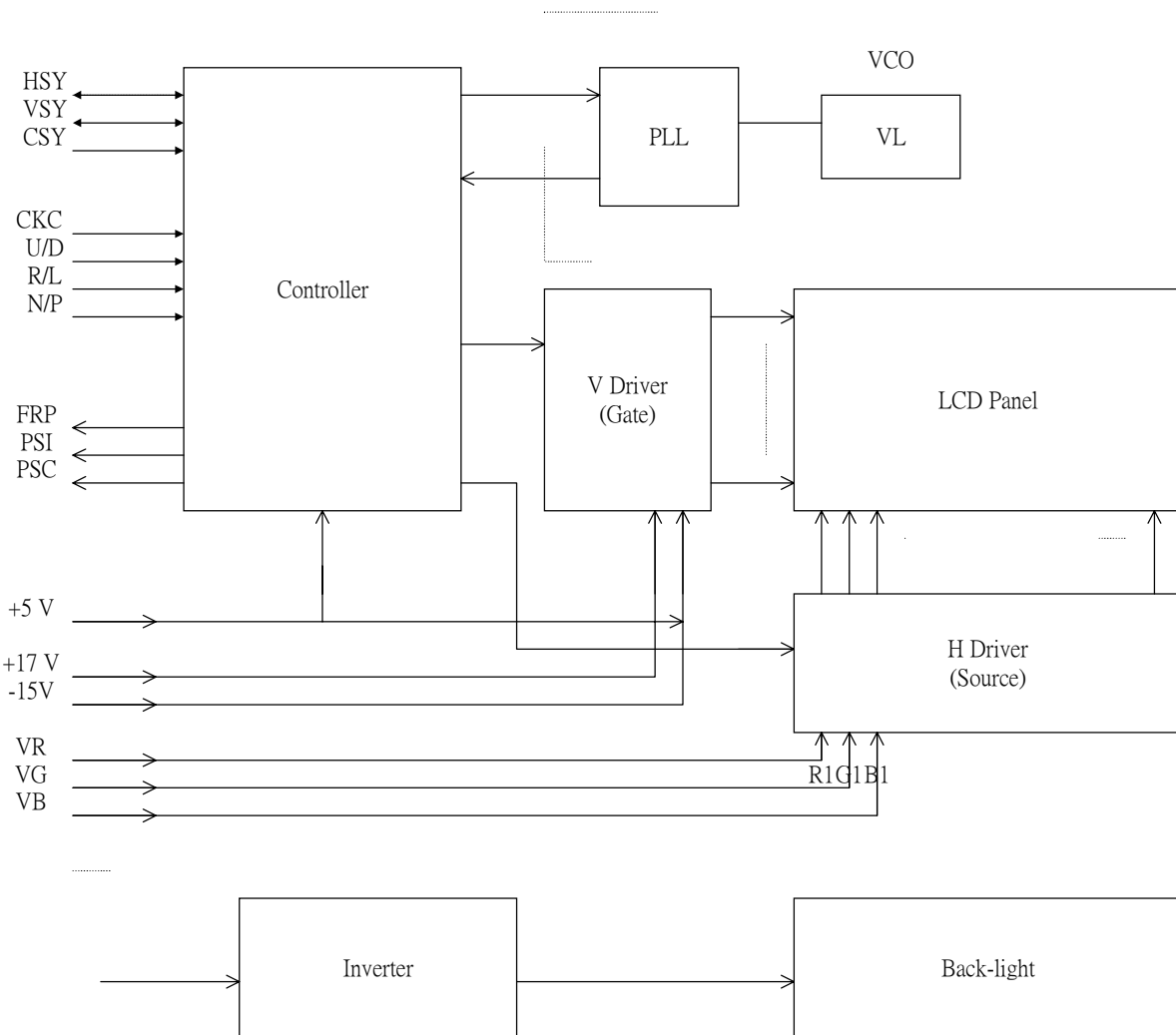

0. Packing

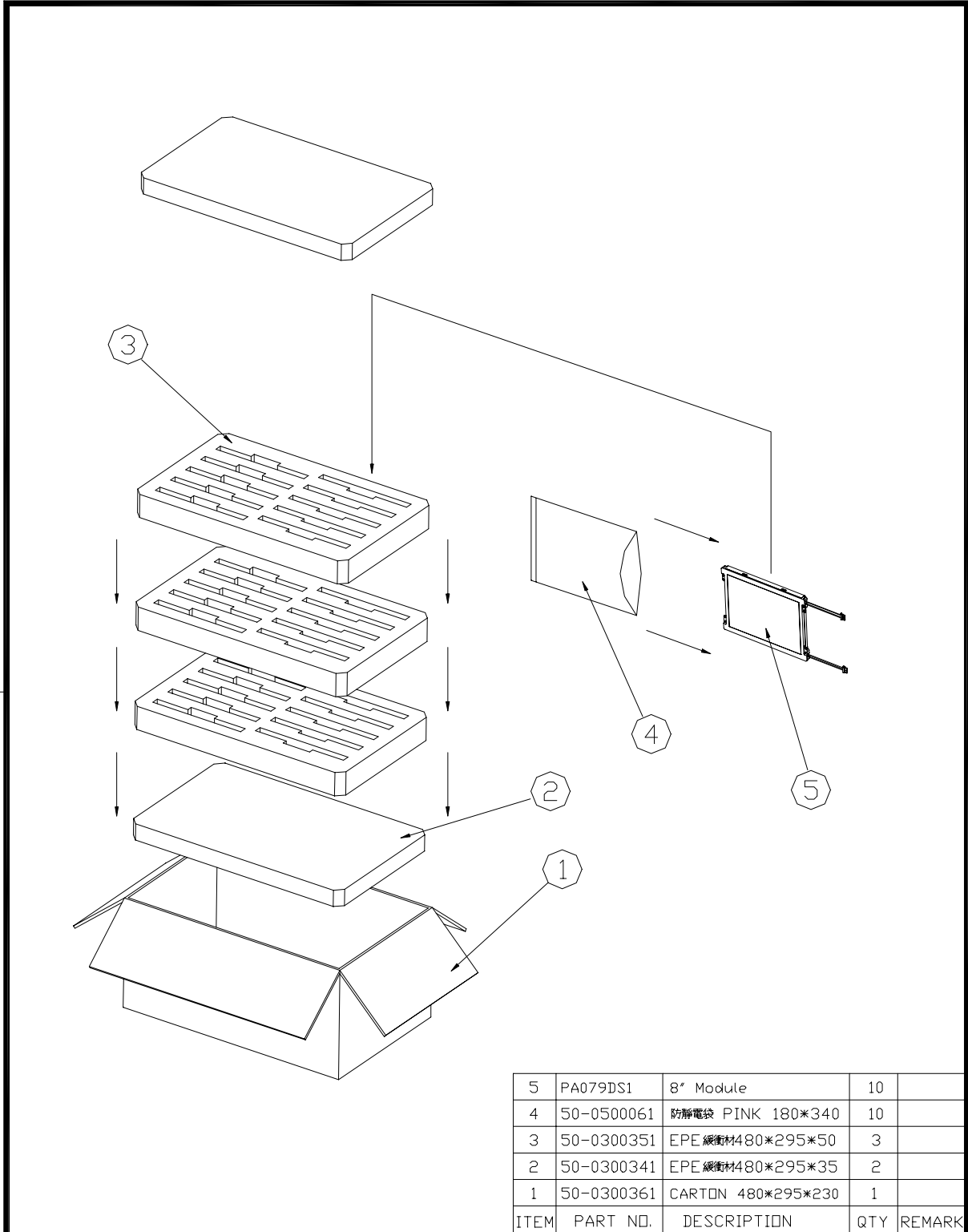

5	PA079DS1	8" Module	10	
4	50-0500061	防靜電袋 PINK 180*340	10	
3	50-0300351	EPE 緩衝材480*295*50	3	
2	50-0300341	EPE 緩衝材480*295*35	2	
1	50-0300361	CARTON 480*295*230	1	
ITEM	PART NO.	DESCRIPTION	QTY	REMARK

MTL.SPEC.		UNSPECIFIED TOL'S		REMARK		元太科技工業股份有限公司 Prime View International Co.,Ltd.	
		ANGLE					
		ROUGHNESS				DWG.TITLE	
APPROVE		SCALE	UNIT	SHEET		7.9" PACKING	
CHECK				1 OF 1			
DESIGN	MJ.Chuang	MTL.NO.		DWG.NO.		REV.	A4 SIZE
	00'07.13						

Revision History

Rev.	Issued Date	Revised Contents
0.1	Sep. 22,2000	NEW
0.2	Mar.13,2001	Modify Note 5-6,Note 5-7 define Add 8-1 White Chromaticity