



K1160AA™ Dual Output Crystal Clock Oscillators

2.4576 MHz to 10.0000 MHz (MOS)
TTL output at twice MOS frequency

.820" x .520" AREA

ALL-METAL WELDED PACKAGE

INSULATED STANDOFFS

DUAL IN-LINE SPACING

+5V dc INPUT

+0%, -0.02% STABILITY

DESIGNED TO DRIVE
ZILOG Z8000 AND Z80A, Z8000A AND Z80B
MOSTEK MK3880-4, MK3880-6, SHARP LH0080A,
AMD AMZ8000, NEC μ PD780C-1,
AND TOSHIBA MICROPROCESSORS
AND PROVIDE SYSTEM TIMING

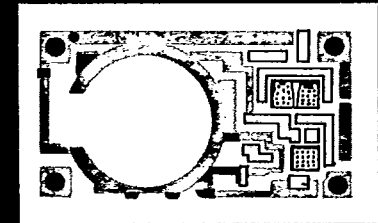
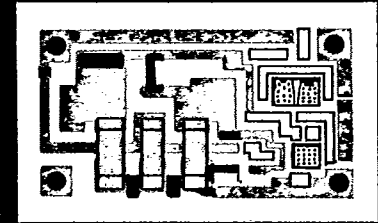
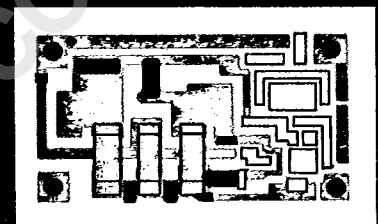
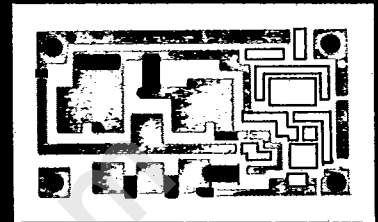
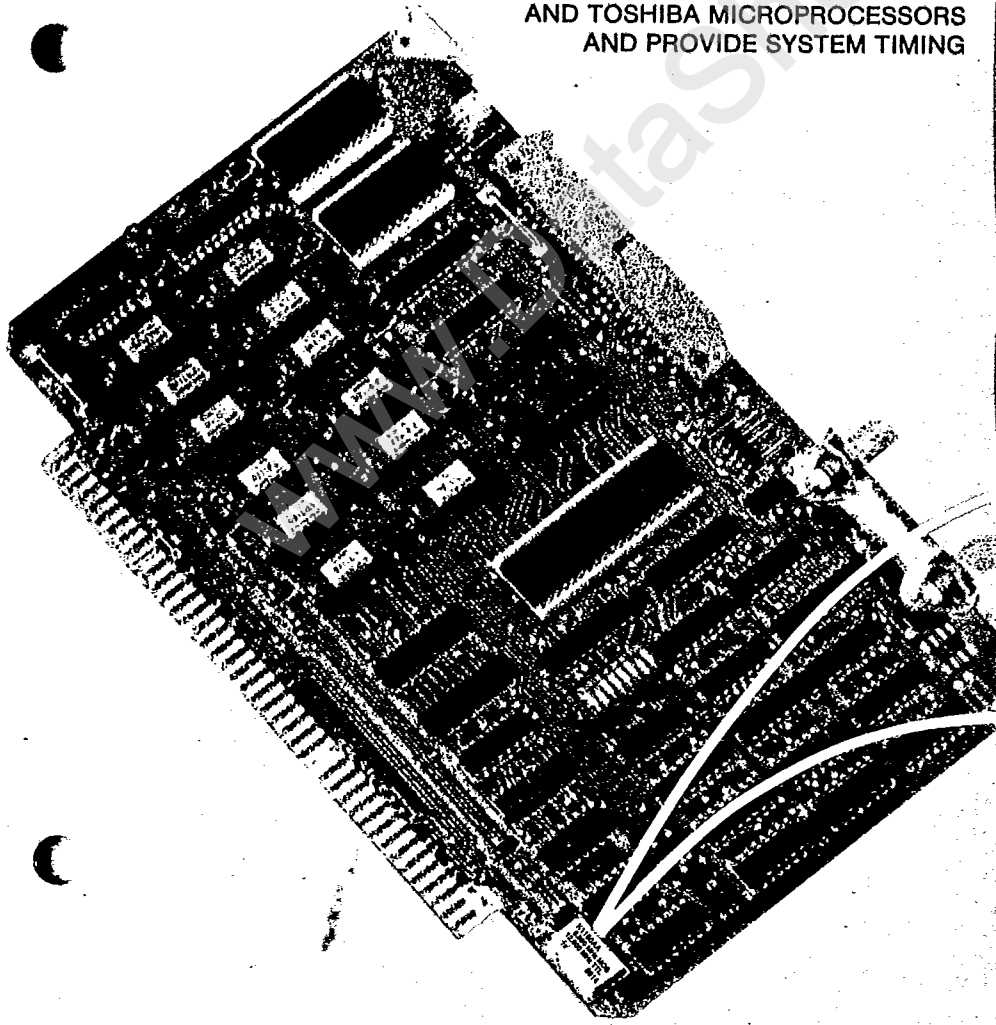

K1160AA
6.000 MHz MOS
12.000 MHz TTL
 8914

Features

■ **MOS AND TTL OUTPUTS**—The K1160AA, designed to drive Zilog Z80A, Z80B, Z8000-type or equivalent 8- and 16-bit microprocessors, is available with NMOS outputs covering a range of 2.4576 to 10 MHz. The oscillator also provides a TTL-compatible output at twice the processor frequency to satisfy system timing requirements.

■ **REDUCES COMPONENT COUNT**—Single thick film hybrid clock with active pull-up on the output replaces approximately 17 discrete components required by conventional techniques. Reduced component count not only reduces required board space but also improves reliability.

■ **HIGH DENSITY PACKAGING**—takes up only .820" x .520" on a circuit board, and its seated height of .270" lets you use standard logic boards with no loss of spacing. Can be soldered directly to the PCB or mounted in a DIP socket, according to your production needs.

■ **+0%, -0.02% STABILITY**—over the range of 0°C to 70°C, suitable for most applications in data communication logic timing. This specification is inclusive of calibration tolerance, stability vs. input voltage change, aging, and stability vs. shock and vibration.

■ **RUGGED, RELIABLE**—maximum reliability at minimum cost is the result of combining two fields of experience; quartz crystal technology and thick film hybrid integrated circuit processing. Mass automated production tech-

niques assure volume production. High precision crystals and clean room processing testify that no shortcuts are taken that might diminish reliability. Environmental testing proves the effectiveness of the rugged design for those applications in which shock and vibration are common hazards.

■ **YOUR TIMING NEEDS IN ONE PACKAGE**—The K1160AA oscillator is designed to provide system timing requirements as well as to drive the microprocessor. The manufacturing savings inherent in this design are passed on to you, simplifying your make vs. buy decision. The K1160AA saves you the board space required by discrete components, and eliminates production man-hours wasted analyzing oscillator circuits and matching crystal parameters to circuit components. And with a packaged oscillator, you eliminate source-hunting and source-qualifying for its components, cut down on direct labor for parts insertion, cut down on overhead costs for Receiving, Incoming Inspection, Purchasing, and Accounts Payable.

■ **COMPLETE PROCESS CONTROL**—Uniform high quality in high volume production is made possible only by complete control of the manufacturing process, from finishing the quartz through hybrid thick film circuit processing and clean room assembly, with stringent quality control measures enforced.

■ **VOLUME PRODUCTION**—Modern automated production techniques are used to provide high volume, high quality crystal clock oscillators.

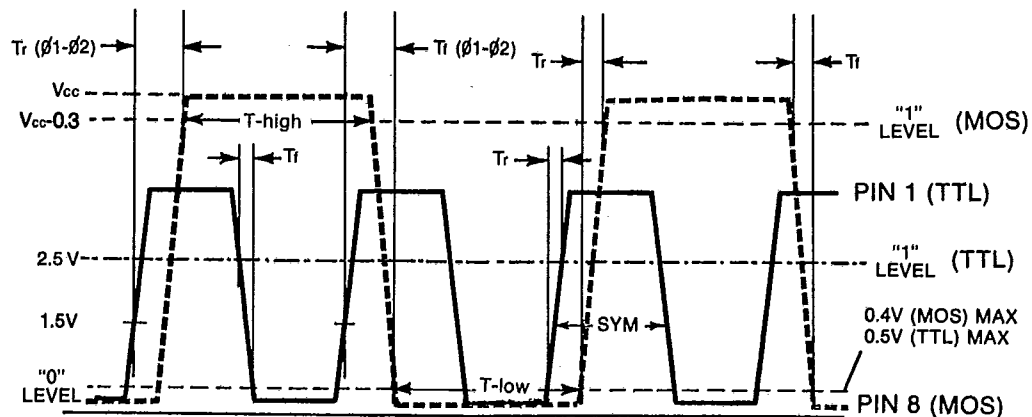

PIN 1 SYM = 40% Min/60% Max
 $T_R (\theta_1 - \theta_2) = 25 \text{ ns Max}$
 $T_F (\theta_1 - \theta_2) = 25 \text{ ns Max}$

specifications

CHAMPION TECHNOLOGIES INC 21E D

- **FREQUENCY:**
Pin 8 (MOS): 2.4576 to 10.0000 MHz
Pin 1 (TTL): twice the pin 8 frequency
- **FREQUENCY STABILITY:** +0%, -.020%
(Inclusive of calibration tolerance at 25°C, operating temperature range, input voltage change, load change, aging, shock, and vibration.)
- **TEMPERATURE RANGE:**
OPERATING: 0°C to 70°C
STORAGE: -55°C to +125°C
- **INPUT VOLTAGE:** +5V dc ±10%
- **INPUT POWER:** 357 mW maximum
- **INPUT CURRENT:**
65 mA max @ 2.4576 to 4.999 MHz Pin 8
80 mA max @ 5.000 to 6.000 MHz Pin 8
90 mA max @ 6.001 to 10.000 MHz Pin 8

STEADY-STATE LIFE:

ELECTROSTATIC DISCHARGE SENSITIVITY:

- **MECHANICAL:**
GROSS LEAK TEST:
HERMETICALLY SEALED PACKAGE:
SEAL STRENGTH:
BEND TEST:

MARKING INK:
SOLVENT RESISTANCE:

MIL-STD-883B, Method 1005
1000 hrs @ 125°C, disregarding frequency shift.
MIL-STD-883B, Method 3015
Class B; >2 KV

Leak test in de-ionized H₂O.

Mass spectrometer leak rate less than 2 × 10⁻⁸ atmos. cc/sec. of helium

20 lbs. max. force perpendicular to top and bottom

Pins will withstand maximum bend of 90° reference to base for 2 bends.

Epoxy, heat cured
Isopropyl alcohol, Trichloroethane
Freon TMC

No marking or seal destruction
Dipped 1 minute @ +25°C ±5°C in solvent

Note: (1) Unit can be cleaned by only one type solvent listed.
Note: (2) Ultrasonic degreaser not to be used.

T-50-23

| SYMBOL | DESCRIPTION | 2.4576-4.000 MHz MOS | | | | 4.001-6.000 MHz MOS | | | | 6.001-10.000 MHz MOS | | | |
|-----------------|------------------------------|--------------------------|------|----------------------|-----------------|--------------------------|------|---------------------|-----------------|--------------------------|------|---------------------|-----------------|
| | | PIN 1 | | PIN 8 | | PIN 1 | | PIN 8 | | PIN 1 | | PIN 8 | |
| F _o | Output Frequency | 2 x F _o Pin 8 | | 2.5 MHz | 4 MHz | 2 x F _o Pin 8 | | 4.001 MHz | 6 MHz | 2 x F _o Pin 8 | | 6.001 MHz | 10 MHz |
| t(∅H) | Pulse Width Load | 10 TTL | | (.5/F _o) | 150 pf | 10 TTL | | .42/F _o | 150 pf | 10 TTL | | .5/F _o | 100 pf |
| t(∅L) | Pulse Width Clock High (sec) | — | | -15 ns | — | — | | .42/F _o | — | — | | -10 ns | — |
| T _r | Clock Rise Time | 10 ns | | — | 15 ns | 10 ns | | — | 10 ns | 10 ns | | — | 10 ns |
| T _f | Clock Fall Time | 10 ns | | — | 15 ns | 10 ns | | — | 10 ns | 10 ns | | — | 10 ns |
| V _{IL} | Low Level | -0.3V | 0.5V | — | 0.4V | -0.3V | 0.5V | — | 0.4V | -0.3V | 0.5V | — | 0.4V |
| V _{IH} | High Level | 2.5V | — | V _{cc} -3V | V _{cc} | 2.5V | — | V _{cc} -3V | V _{cc} | 2.5V | — | V _{cc} -3V | V _{cc} |

(Symmetry and phase relationship expressed on front page wave form.)

- **ENVIRONMENTAL:**
TEMPERATURE CYCLE: MIL-STD-883B Method 1010.2 Level B
SHOCK: 1000 G's 0.35 millisecond, 1/2 sine wave; 3 shocks each plane
VIBRATION: 10-55 Hz, .060" D.A., 55 Hz-2000 Hz 35 G's. Duration time—12 hours
HUMIDITY: 85% Relative humidity, @ +85°C, 500 hrs.

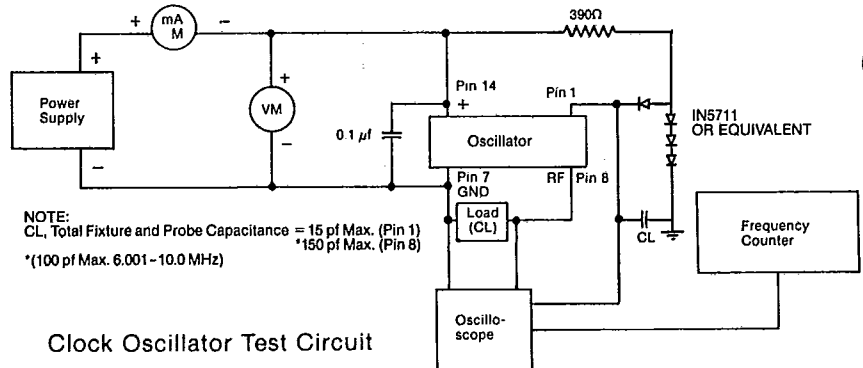

solderability specifications

- **MATERIALS:**
SOLDER: 60% tin and 40% lead
FLUX: Mildly activated rosin base type such as Alpha 611.
- **PROCEDURE:**
PREPARATION: No wiping, cleaning, scraping, or abrading shall be performed on the leads.
SOLDER BATH: The solder bath shall be maintained at 265 ±5°C.
SOLDERABILITY: Dip the terminals into room temperature flux, to a maximum of .020" from the unit base, for 5 to 10 seconds. Withdraw from the flux and dip the terminals to the same depth in the molten solder from 5 to 7 seconds. Flux residue may be removed with Freon rinse, or with soft swab moistened with isopropyl alcohol or Freon.
- **REQUIREMENTS:**
EVALUATION: All leads must exhibit a minimum of 90% continuous solder coating over their entire length beyond .020" from the unit base. Pinholes or voids may not be concentrated in any one area and are not to exceed 10% of the total area under examination.

Zilog, Z8000, Z80A, Z8000A, Z80B, Mostek, MK3880-4, MK3880-6, Sharp, LH0080A, AMD, AMZ8000, NEC μPD780C-1, and Toshiba are trademarks of their respective companies.

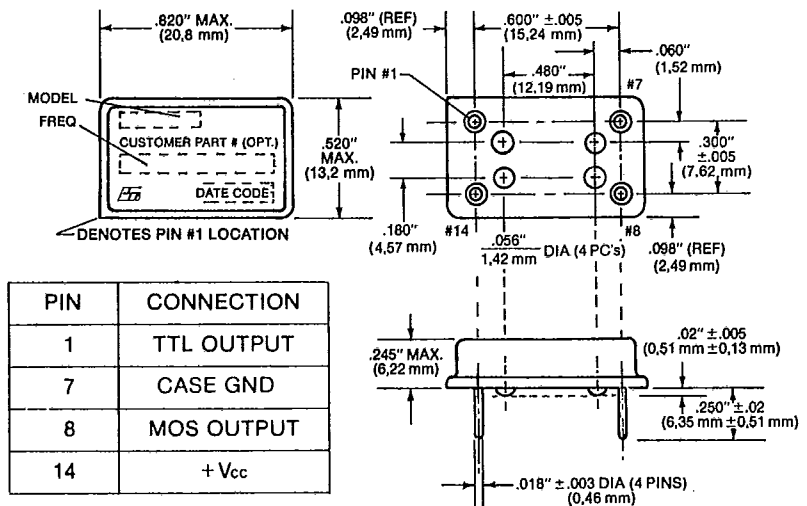

Specifications subject to change without notice.
Zilog, Mostek and K1160AA are trademarks of Champion Technologies, Inc. © 1989 by Champion Technologies, Inc.



2553 N. Edgington Street
Franklin Park, IL 60131
708/451-1000 FAX: 708/451-7585
EasyLink: 62931824 Telex: 499-0104 CTI UD Printed in U.S. A