

AN8245K, AN8245SCR

Laser Disk Spindle Motor Controller

Overview

The AN8245K and AN8245SCR are speed control drive ICs of the brushless motors by means of the 3-phase full-wave current drive system. They are suitable for controlling/driving the laser disk spindle motors, LBP polygon mirror motors, and so on.

Features

- Operating supply voltage range : $V_{CC1} = 10.8$ to $13.2V$
 $V_{CC2} = 10.8$ to $22V$
- 3-sensor 3-phase full-wave current drive ; power transistor built-in
- Maximum motor drive current : $I_{Mmax} = 1.5A$
- Digital PLL control
- Bidirectional torque control
- Provided with reverse detector and stop detector
- Synchronizing signal and stop signal output
- Built-in thermal protective and current limiter functions

Applications

Control and drive of the Hall motors such as laser disk spindle motors, LBP polygon motors, and so on

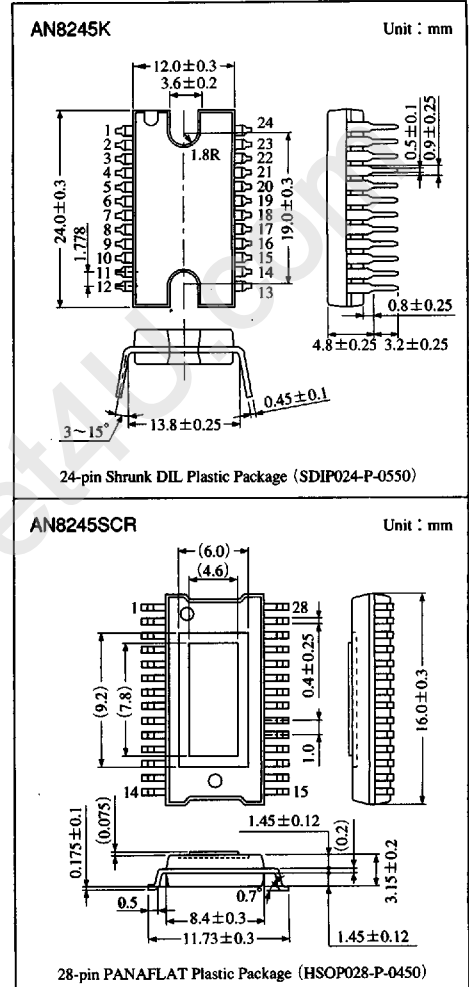

Block Diagram

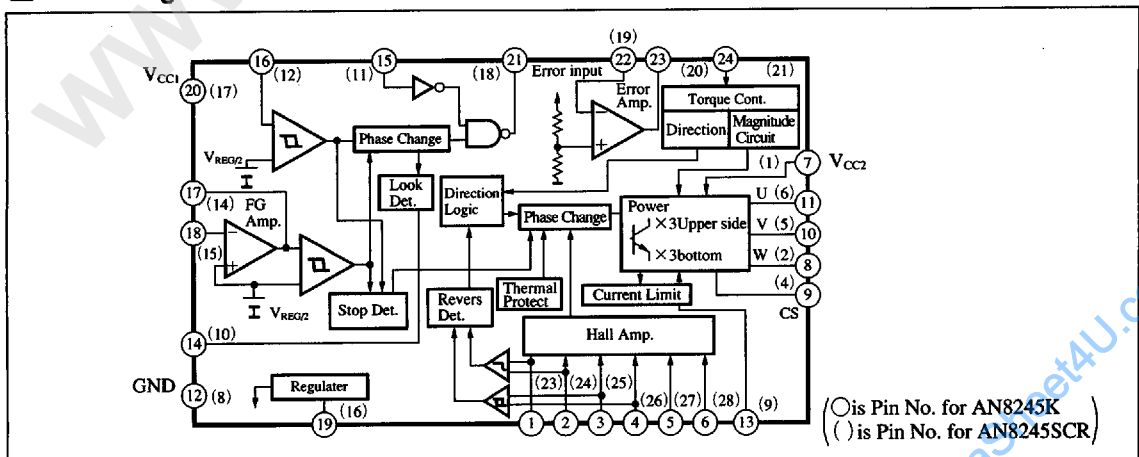

6932852 0012876 7T8

■ Absolute Maximum Ratings (Ta=25°C)

Parameter	Symbol	Rating	Unit
1st supply voltage	V _{CC1}	15	V
2nd supply voltage	V _{CC2}	24	V
1st supply current	I _{CC1}	40	mA
Motor drive pin voltage	AN8245K	V ₈ , V ₁₀ , V ₁₁	24
	AN8245SCR	V ₂ , V ₅ , V ₆	24
Hall amp. input pin applied voltage	AN8245K	V ₁ ~V ₆	0 to V _{CC1}
	AN8245SCR	V ₂₃ ~V ₂₈	0 to V _{CC1}
Pin applied voltage	AN8245K	V ₁₄ ~V ₂₁	0 to V _{CC1}
	AN8245SCR	V ₁₀ ~V ₁₈	0 to V _{CC1}
Limiter control pin applied voltage	AN8245K	V ₁₃	to 5
	AN8245SCR	V ₉	to 5
Motor drive pin rush current	AN8245K	I ₈ , I ₁₀ , I ₁₁	-2 to +2 Note 1)
	AN8245SCR	I ₂ , I ₅ , I ₆	
Current detection pin rush current	AN8245K	I ₉	-2 to 0 Note 1)
	AN8245SCR	I ₄	
Regulator voltage output pin current	AN8245K	I ₁₉	-20 to +0.5
	AN8245SCR	I ₁₆	
Power dissipation	AN8245K	P _D	2500
	AN8245SCR	P _D	1400
Operating ambient temperature	T _{opr}	-20 to +75	°C
Storage temperature	T _{stg}	-55 to +150	°C

Note 1) Single-shot pulse width : 50ms or less

■ Recommended Operating Range (Ta=25°C)

Parameter	Symbol	Range
Operating supply voltage range	V _{CC1}	10.8V to 13.2V
	V _{CC2}	10.8V to 22V

ICs for
Motor

■ Electrical Characteristics (Ta=25°C)

Parameter	Symbol	Condition	min	typ	max	Unit
1st supply current	I _{CC}	V _{CC1} =12V, V _{IH} =0V	10	15	20	mA
2nd supply current at standby	I _{QS}	V _{CC1} =12V, V _{IH} =5V	—	0	0.1	mA

Regulator Voltage Output Block

Output voltage	V _{OR}	V _{CC1} =12V, I _{OR} =0mA	7.5	8	8.5	V
Output current	I _{OR}	V _{CC1} =12V	—	—	10	mA
Output impedance	Z _{OR}	V _{CC1} =12V	—	2	8.5	Ω

FG Amp./Schmidt Block

Amp. offset voltage	V _{OSF}	V _{CC1} =12V	—	—	55	mV
Hysteresis width	V _{SF}	V _{CC1} =12V	80	110	140	mV
Stop detector voltage	V _{RF}	V _{CC1} =12V	—	—	170	mV
Amp. output voltage H	V _{OHF}	V _{CC1} =12V	10	—	—	V
Amp. output voltage L	V _{OLF}	V _{CC1} =12V	—	—	1	V
Output impedance	Z _{OF}	V _{CC1} =12V	—	60	100	Ω

Phase Comparator Output L Block

V _{OR} ⁻ (phase comparator output H)	V _{PHH}	V _{CC1} =12V	—	—	0.4	V
Phase comparator output L	V _{PHL}	V _{CC1} =12V	—	—	0.4	V

■ 6932852 0012877 634 ■

Panasonic

Electrical Characteristics (Cont.) ($T_a=25^\circ\text{C}$)

Parameter	Symbol	Condition	min	typ	max	Unit
Phase Comparator Output L Block (Cont.)						
Output sink current	I_{PH}^+	$V_{CC1}=12\text{V}$	2.5	—	—	mA
Output source current	I_{PH}^-	$V_{CC1}=12\text{V}$	300	350	—	μA
Error Amp. Output Block						
Output offset voltage	V_{OSE}	$V_{CC1}=12\text{V}$	—	—	50	mV
Amp. output voltage H	V_{OHE}	$V_{CC1}=12\text{V}$	10	—	—	V
Amp. output voltage L	V_{OLE}	$V_{CC1}=12\text{V}$	—	—	1	V
Output impedance	Z_{OE}	$V_{CC1}=12\text{V}$	—	60	100	Ω
Start/Brake						
Input voltage L	V_{ILS}	$V_{CC1}=12\text{V}$	—	—	0.8	V
Input voltage H	V_{IHS}	$V_{CC1}=12\text{V}$	2.4	—	—	V
Input low current	I_{IS}	$V_{CC1}=12\text{V}$	-5	-1	—	μA
Phase Lock Signal Output						
Output voltage H	V_{OHL}	$V_{CC1}=12\text{V}$	4.5	5	—	V
Output voltage L	V_{OLL}	$V_{CC1}=12\text{V}$	—	—	0.4	V
Drive Block (Phase Lock Mode)						
Forward torque command offset	V_{OFD}	$V_{CC1}=12\text{V}$	-10	—	200	mV
Reverse torque command offset	V_{ORD}	$V_{CC1}=12\text{V}$	-100	—	10	mV
Dead zone	V_{DZ}	$V_{CC1}=12\text{V}$	30	—	250	mV
Output idle voltage	V_{ID}	$V_{CC1}=12\text{V}$	—	0.8	10	mV
Forward again	G_{DF}^+	$V_{CC1}=12\text{V}$	0.4	0.5	0.6	times
Reverse again	G_{DF}^-	$V_{CC1}=12\text{V}$	-0.6	-0.5	-0.4	times
Drive (Phase Lock Mode)						
Start command voltage	V_{STA}	$V_{CC1}=12\text{V}$	6	6.6	—	V
Stop command voltage	V_{STO}	$V_{CC1}=12\text{V}$	—	0.8	1.5	V
Forward limiter voltage	V_L^+	$V_{CC1}=12\text{V}$ Start command voltage $V_{DTC}=V_{STA}$	0.73	0.82	0.9	V
Reverse limited voltage	V_L^-	$V_{CC1}=12\text{V}$ Start command voltage $V_{DTC}=V_{STO}$	0.73	0.82	0.9	V
Hall Amp.						
Hall input sensitivity	V_{ISH}	$V_{CC1}=12\text{V}$	—	—	50	mV
Hall offset voltage	V_{OSH}	$V_{CC1}=12\text{V}$	—	—	20	mV
Common mode input range	V_{ICH}	$V_{CC1}=12\text{V}$	2	—	$V_{CC1}-2$	V
Differential input range	V_{IDH}	$V_{CC1}=12\text{V}$	—	—	400	mV
Power Block						
Saturation voltage on V_{CC}	V_{SU}	$V_{CC1}=12\text{V}$	—	—	1.5	V
Saturation voltage on ground	V_{SL}	$V_{CC1}=12\text{V}$	—	—	1	V
Off leak current	I_{LO}	$V_{CC1}=12\text{V}$	—	0	—	mA
FG Reference Single Processing						
Hysteresis width	V_{SR}	$V_{CC1}=12\text{V}$	0.5	0.65	0.8	V
Threshold voltage H	V_{OHR}	$V_{CC1}=12\text{V}$	1.8	—	2.5	V
Threshold voltage L	V_{OLR}	$V_{CC1}=12\text{V}$	1.2	1.5	1.8	V
Thermal Protective Circuit						
Thermal protection operating point	T_P	$V_{CC1}=12\text{V}$	—	170	—	$^\circ\text{C}$
Hysteresis width	T_{HP}	$V_{CC1}=12\text{V}$	—	20	—	$^\circ\text{C}$
Stop detector frequency	f_s	$V_{CC1}=12\text{V}$	—	Fref/16	—	Hz

■ 6932852 0012878 570 ■

Panasonic

Application Circuit

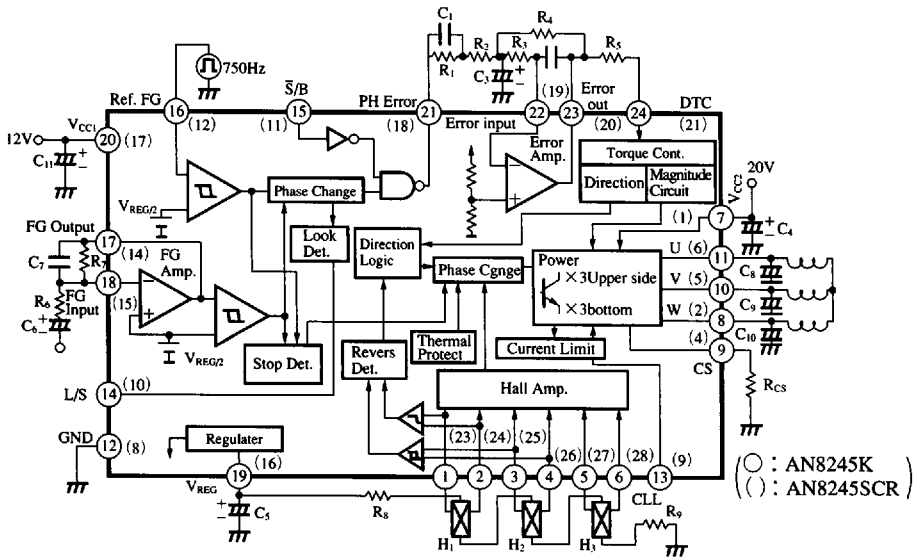

Pin Descriptions

(Pin Nos. in ○ for AN8245K, Pin Nos. in () for AN8245SCR)

Pin No.		Pin name	Typical waveform	Description	Pin equivalent circuit
AN8245K	AN8245SCR				
7	1	2nd supply voltage (V _{CC2})	—	2nd power pin to supply the motor drive current	—
8	2	Motor drive output W	—	Motor drive output W pin	
	3	NC	—	Open pin	—
9	4	Current detection (CS)	—	Pin to detect the current required to drive the motor	
10	5	Motor drive output V (V)	—	Motor drive output V pin	
11	6	Motor drive output U (U)	—	Motor drive output U pin	

6932852 0012879 407

Pin Descriptions (Cont.)

Pin No.		Pin name	Typical waveform	Description	Pin equivalent circuit
AN8245K	AN8245SCR				
	7	NC	—	Open pin	—
12	8	Ground (GND)	—	Ground pin	—
13	9	Limiter voltage control (CLL)	—	Pin to change the motor drive current limiting volt voltage	
14	10	Phase lock signal output (L/S)	—	Lock detection output pin by PLL control of the phase at motor rotation	
15	11	Start/brake signal input (S/B)	—	Start/brake signal input pin	
16	12	FG reference signal input (Ref FG)	—	FG reference signal input pin required for PLL control	
	13	NC	—	Open pin	—
17	14	FG amp. output (FG OUT)		Output pin of the FG amp.	
18	15	FG amp. inverting input (FG IN)		Inverting input pin of the FG amp.	
19	16	Regulator voltage output (V _{REG})		Regulator voltage output pin	

6932852 0012880 129

Pin Descriptions (Cont.)

Pin No.		Pin name	Typical waveform	Description	Pin equivalent circuit
AN8245K	AN8245SCR				
20	17	1st supply voltage (V _{CC1})	—	1st power pin to supply the voltage to the control circuit	—
21	18	Phase comparison output (PH Error)	—	Phase comparison output pin required for PLL control	
22	19	Error amp. invert-ing input (Error in)	—	Amp. circuit to amplify a phase/speed error signal and convert a torque signal	
23	20	Error amp. output (Error out)			
24	21	Torque control input (DTC)	—	Motor torque control input pin	
	22	NC	—	Open pin	—
1 3 6	23 25 28	Hall amp. 1 ⁺ to 3 ⁻ inputs H ₁ ⁺ H ₂ ⁺ H ₃ ⁻	—	Hall element output input pin	

Supplementary Explanation

The AN8245K and AN8245SCR have been developed as single-chip ICs for controlling and driving the laser spindle motors. They can be also available for controlling and driving the 3-phase brushless motors. Their functions and features are described below.

1. Drive block

- 3-phase full-wave drive (1.5A)
- Current drive (current feedback available)
- Built-in motor current limiter
(current limiter level variable)*¹
- Built-in thermal protective function
- Reverse rotation torque brake*²
- Built-in reverse detector

2. Control block

- PLL speed control method*³
- Digital phase comparator
- Start/brake control pin
- Phase lock detection pin

*¹ A motor current is detected by the resistor R_{CS} between the Pin^⑨ (4) and GND. Since the potential of the Pin^⑨ (4) (CS pin) is controlled so that a value may not exceed a specified voltage (current limiter level) V_L, the maximum motor current can be specified by V_L/R_{CS}. Because of the voltage of the Pin^⑬ (9) (CLL pin) = V_L, V_L can be made variable by connecting a resistor between GNDs via the Pin^⑬ (9).

*² As the potentials of the torque command and DTC pin (Pin^⑳ (21)) go below 1/2 · V_{reg}, a torque is to be generated in the reverse rotating direction. As a result, the motor load with large inertia can be stopped and transient response can be improved.

To prevent the motor from rotating in the reverse direction, the following functions are provided :

- Motor current OFF function : When detecting a stop
- Forward full torque function : when detecting reverse rotation

*³ The reference pulse to be input from the Pin^⑯ (12) (Ref.FG pin) and the pulse due to FG amp. waveform shaping are compared as to their digital phases to control the PLL speed. PLL of these ICs consists of a phase loop only in the from that dumping is obtained through the filters around the error amplifier.

6932852 0012881 065

■ Supplementary Description (Cont.)

Operational Chart of Pins

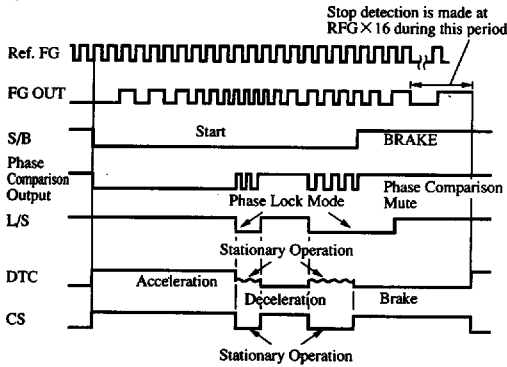

• Setting the External Parts (Refer to Product Specifications and Block Diagram)

1. Drive block

- $C_8 \sim C_{10}$: Connected between the phases of 3-phase coils or GNDs for absorbing the voltage spike of drive output by current drive (120 deg. conducted) or preventing oscillation of drive output. When oscillation tends to occur, it is recommended to insert a resistor of 10 to 500Ω in series with C (several μF as a capacity value).
- R_8, R_9 : Determine the Hall element current. It is recommend to set the Hall element output to about typ. 100 to 200mVpp.
- R_{CS} : Determine the control system gain and the maximum motor current.
- C_4, C_5, C_{11} : Used for decoupling the power supply and stabilized voltage output.

2. Control block

- R_6, R_7, C_6, C_7 : Set the filter for eliminating noise of a speed detecting FG signal and the FG amp. gain.

FG amp. gain $G_{FG} = R_7/R_6$

Filter constant

$$f_L = \frac{1}{2\pi C_6 R_6} \text{ (Hz)}$$

$$f_H = \frac{1}{2\pi C_7 R_7} \text{ (Hz)}$$

FC frequency $f_{FG} = f_L < f_{FG} < f_H$

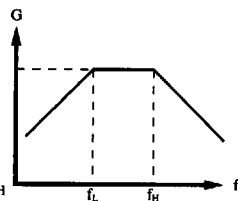

- $R_1 \sim R_4, C_1, C_2$: Constitute the dumping filter for the control system and the ripple filter for phase comparison output.
- R_5 : Connects 10kΩ as the current control load of the transistor switch (operated at start and reverse motor drive detection) which is connected to the Pin⑳ (21) in the IC.

3. Design of the control system

The following describes the important points when designing the speed control system with these ICs. The control system is shown in the following block diagram.

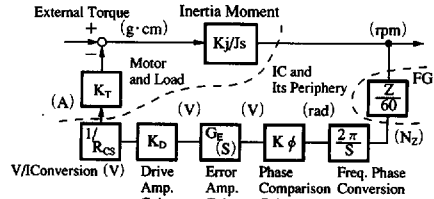

- K_T : Motor torque constant (gcm/A)
- J : Sum (gcm²) of inertia moment of the motor and load (disc, etc.)
- S : Laplacian operator
- K_j : Coefficient for changing a torque (gcm) into a motor speed (r.p.m.) 9.36×10^3
- Z : Number of FG teeth
- K_ϕ : IC phase comparison gain $8/2\pi$ (V/rad)
- $G_E(S)$: Dumping of the error amp. block and the gain of the ripple filter
- K_D : IC drive amp. gain 0.4 to 0.6
- $1/R_{CS}$: V/I conversion gain by the IC and external resistor $R_{CS}1/R_{CS}$ (A/V).

Make the following calculation, using the constants above.

$$A(S) = K_j/J_s$$

$$B(S) = \frac{Z}{60} \cdot \frac{2\pi}{S} K_\phi \cdot G_E(S) \cdot K_D \cdot \frac{1}{R_{CS}} \cdot K_T$$

At this time, the motor speed change ΔN for disturbance torque ΔT is as follows.

$$\frac{\Delta N}{\Delta T} = \frac{A(S)}{1 + A(S)B(S)} = \frac{1}{1/A(S) + B(S)}$$

When $1/A(S) \gg B(S)$, $\frac{\Delta N}{\Delta T} \approx A(S)$, and when $1/A(S) \ll B(S)$, $\frac{\Delta N}{\Delta T} \approx 1/B(S)$.

If shown in the figure, it will be almost as shown in the right one.

It is better for stable operation to satisfy the following conditions.

- $f_{D2} \geq 3 \cdot f_0$
- $f_{R1} \geq 5 \cdot f_0$
- $f_{D1} \leq f_0/3$
- f_{FG} (FG frequency) $\geq 20f_0$

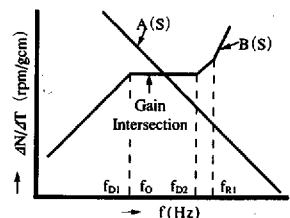

■ Supplementary Description (Cont.)

f_{D1} , f_{D2} , and f_{R1} are determined as follows.

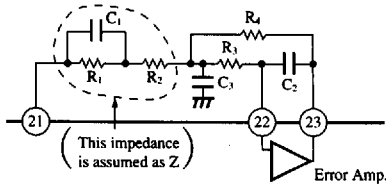

The figure above shows an example of the external circuit around the error amplifier. This block constitutes the damping filter for the control system and the ripple filter for phase comparison output.

$$G_E(S) = \frac{R_4}{Z} \cdot \frac{1}{1 + sC_2R_3R_4 \left(\frac{1}{Z} + \frac{1}{R_3} + \frac{1}{R_4} \right) + s^2C_2C_3R_3R_4}$$

$$Z = (R_1 + R_2) \frac{1 + sC_1(R_1/R_2)}{1 + sC_1R_1}$$

The transfer function $G_E(S)$ of these filters are represented by the following expression, indicating the characteristics of the damping filter in Item 1 and of the ripple filter in Item 2.

Damping filter : $f_{D1} = 1/(2\pi C_1R_1)$

$$f_{D2} = 1/\{2\pi C_1(R_1/R_2)\}$$

Ripple filter :

$$f_{R1} = 1/2\pi\sqrt{C_2C_3R_3R_4}$$

$$\zeta = \left\{ C_2C_3C_4 \left(\frac{1}{Z} + \frac{1}{R_3} + \frac{1}{R_4} \right) \right\} / 2\sqrt{C_2C_3R_3R_4}$$

■ Characteristics Curve

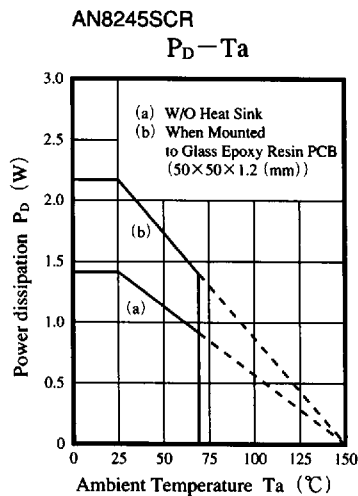
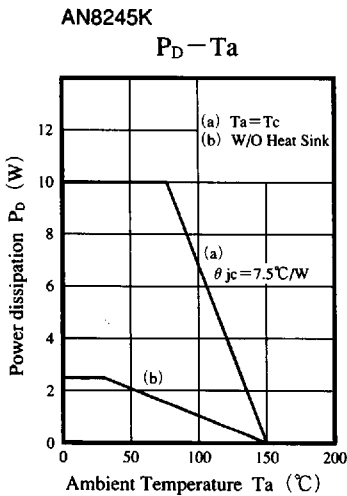

ICs for Motor