

IN1489A

Quadruple Line Receivers

The IN1489A is a monolithic quadruple line receivers designed to satisfy the requirements of the standard interface between data terminal equipment and data communication equipments as defined by EIA standard RS-232C. A separate response control terminal is provided for each receiver. A resistor or a resistor and bias voltage can be connected between this terminal and ground to shift the input threshold voltage levels. An external capacitor can be connected from this terminal to ground to provide input noise filtering.

- Input Resistance ... 3 kΩ to 7kΩ
- Input Signal Range ... ±30 V
- Operates from Single 5 V Supply
- Built-IN Input Hysteresis (Double Thresholds)
- Response Control Provides: Input Tresold Shifting
Input Noise Filtering
- Satisfies Requirements of EIA RS-232C

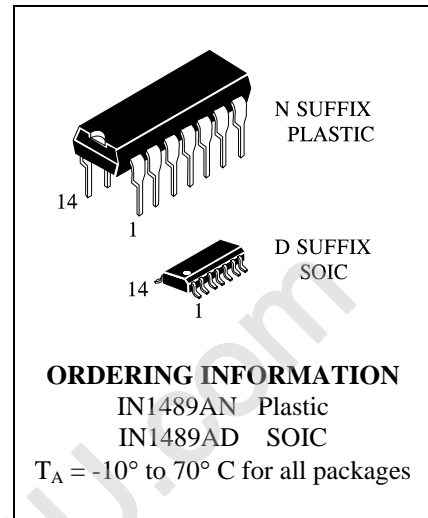

LOGIC DIAGRAM

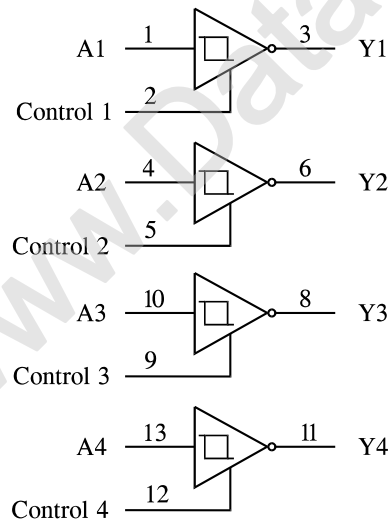

PIN 14 = V_{CC}
 PIN 7 = GND

PIN ASSIGNMENT

A1	1	14	V _{CC}
Control 1	2	13	A4
Y1	3	12	Control 4
A2	4	11	Y4
Control 2	5	10	A3
Y2	6	9	Control 3
GND	7	8	Y3

FUNCTION TABLE

Inputs	Output
A	Y
L	H
H	L

MAXIMUM RATINGS*

Symbol	Parameter	Value	Unit
V _{CC}	Supply Voltage	6	V
V _{IN}	Input Voltage	±25	V
I _O	Output Current	10	mA
T _{stg}	Storage Temperature Range	-65 to +150	°C

*Maximum Ratings are those values beyond which damage to the device may occur. Functional operation should be restricted to the Recommended Operating Conditions.

RECOMMENDED OPERATING CONDITIONS

Symbol	Parameter	Min	Max	Unit
V _{CC}	Supply Voltage		5.5	V
V _{IH}	High Level Input Voltage		25	V
V _{IL}	Low Level Input Voltage	-25		V
I _{OL}	Low Level Output Current		10	mA
T _A	Ambient Temperature Range	-10	+70	°C

DC ELECTRICAL CHARACTERISTICS over full operating conditions

Symbol	Parameter	Test Conditions	Guaranteed Limit		Unit
			Min	Max	
V _{T+}	Positive-Going Threshold Input Voltage		1.75	2.25	V
V _{T-}	Negative-Going Threshold Voltage		0.75	1.25	V
V _{OH}	High-Level Output Voltage	V _I = 0.75 V, I _{OL} = -0.5 mA	2.6		V
		Input open, I _{OH} =-0.5 mA	2.6		
V _{OL}	High-Level Output Voltage	V _I = 3 V, I _{OL} = 10 mA		0.45	V
I _{IH}	High Level Input Current	V _I =25 V	3.6	8.3	mA
		V _I =3 V	0.43		
I _{IL}	Low Level Input Current	V _I =-25 V	-3.6	-8.3	mA
		V _I =-3 V	-0.43		
I _{OS}	Short Circuit Output Current			-4.0	mA
I _{CC}	Supply Current	V _I =5 V, Outputs open		26	mA

AC ELECTRICAL CHARACTERISTICS (T = 25°C, V_{CC} = 5.0 V, C_L = 15 pF, t_r=t_f=5 ns)

Symbol	Parameter	Test Conditions	Min	Max	Unit
t _{PLH}	Propagation Delay Time, Low-to-High Level Output (Figure 1)	R _L =3.9 kΩ		85	ns
t _{PHL}	Propagation Delay Time, High-to-Low Level Output (Figure 1)	R _L =390 kΩ		50	ns
t _{TLH}	Transition Time, Low-to-High Level Output (Figure 1)	R _L =3.9 kΩ		300	ns
t _{THL}	Transition Time, High-to-Low Level Output (Figure 1)	R _L =390 kΩ		24	ns

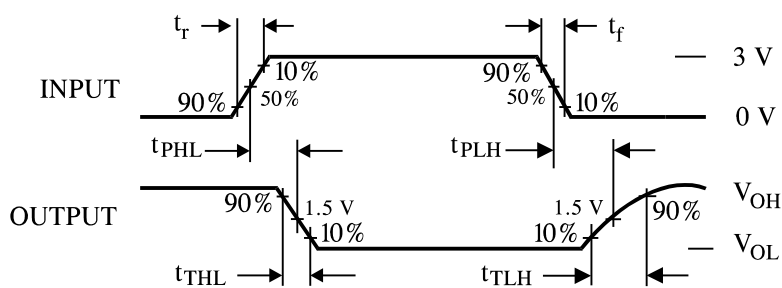
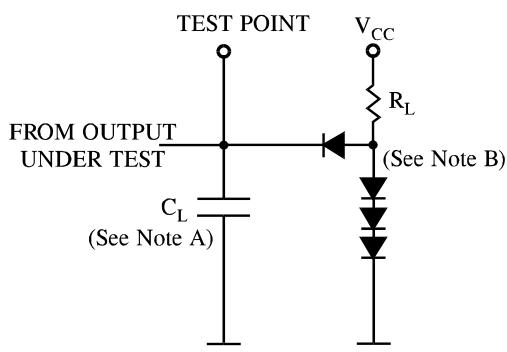

Figure 1. Switching Waveforms



NOTES A. C_L includes probe and jig capacitance.
 B. All diodes are 1N916 or 1N3064/

Figure 2. Test Circuit

**N SUFFIX PLASTIC DIP
(MS - 001AA)**

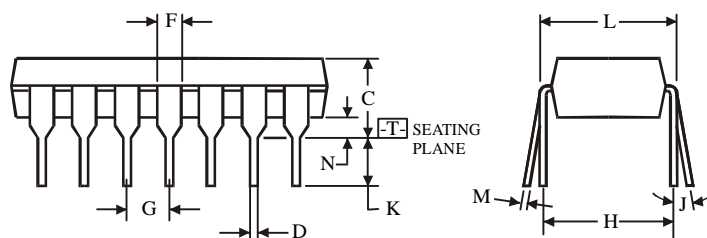
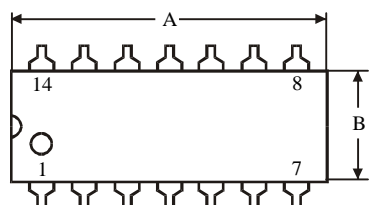
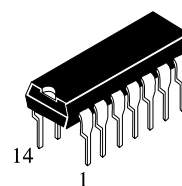

$\oplus 0.25 (0.010) \text{ (M) T}$

NOTES:

- Dimensions "A", "B" do not include mold flash or protrusions.
Maximum mold flash or protrusions 0.25 mm (0.010) per side.

Symbol	Dimension, mm	
	MIN	MAX
A	18.67	19.69
B	6.1	7.11
C		5.33
D	0.36	0.56
F	1.14	1.78
G	2.54	
H	7.62	
J	0°	10°
K	2.92	3.81
L	7.62	8.26
M	0.2	0.36
N	0.38	

**D SUFFIX SOIC
(MS - 012AB)**

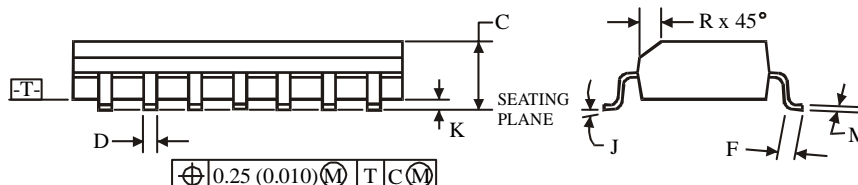
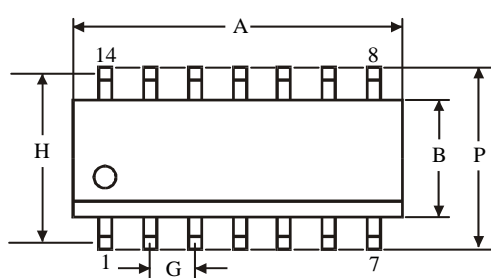
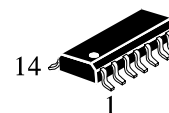

$\oplus 0.25 (0.010) \text{ (M) T C (M)}$

NOTES:

- Dimensions A and B do not include mold flash or protrusion.
- Maximum mold flash or protrusion 0.15 mm (0.006) per side for A; for B - 0.25 mm (0.010) per side.

Symbol	Dimension, mm	
	MIN	MAX
A	8.55	8.75
B	3.8	4
C	1.35	1.75
D	0.33	0.51
F	0.4	1.27
G	1.27	
H	5.27	
J	0°	8°
K	0.1	0.25
M	0.19	0.25
P	5.8	6.2
R	0.25	0.5