

Thin Film Chip Inductors

Type KL73 1206

ISO 9001:2000
CERTIFIED
TS-16949
CERTIFIED

1. Scope

This specification applies to Thin Film Chip Inductors (KL73) 2B size produced by KOA Corporation.

2. Type Designation

The type designation shall be the following form:

New Type

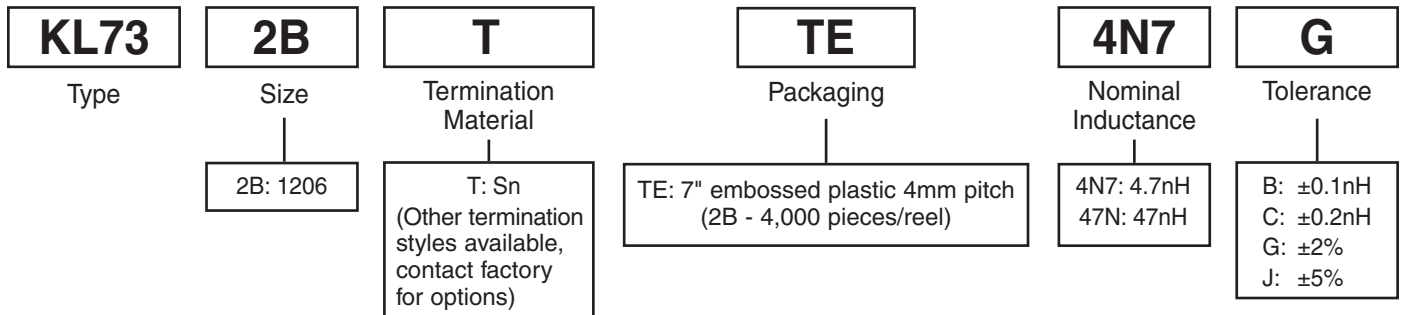

3. Rating

Item	Ratings
Nominal Inductance Range (nH)	2.2 ~ 100 (E-12 series)
Inductance Tolerance	± 2%, ± 5% (± 0.2nH: Under 4.7nH)
Quality Factor (typ.)	15 ~ 40
Self Resonant Frequency (typ.) (MHz)	400 ~ 9,000
DC Resistance (typ.) (Ω)	0.25 ~ 2.00
Allowable Current (max.) (mA)	250 ~ 1,000
Operating Temperature Range (°C)	-40°C ~ +85°C
Storage Temperature Range (°C)	-40°C ~ +125°C

Rating Table

Part Designation	Inductance (nH)	Inductance Tolerance	Quality Factor Minimum	Self Resonant Frequency Minimum (MHz)	DC Resistance Maximum (Ω)	Allowable DC Current Maximum (mA)	Measured Frequency (MHz)
KL732BTTE2N2*	2.2	C: ± 0.2 nH	25	9000	0.25	1000	500
KL732BTTE2N7*	2.7			7000			
KL732BTTE3N3*	3.3			6000			
KL732BTTE3N9*	3.9		35	5000		900	
KL732BTTE4N7*	4.7			4500			
KL732BTTE5N6*	5.6	G: $\pm 2\%$ J: $\pm 5\%$	35	4000	900		
KL732BTTE6N8*	6.8			3500			
KL732BTTE8N2*	8.2			3000	800		
KL732BTTE10N*	10			2500			
KL732BTTE12N*	12		40	1.00	2000	500	
KL732BTTE15N*	15						
KL732BTTE18N*	18						
KL732BTTE22N*	22			25	1500	400	
KL732BTTE27N*	27				1000		
KL732BTTE33N*	33				15		500
KL732BTTE39N*	39						
KL732BTTE47N*	47	400					
KL732BTTE56N*	56						
KL732BTTE68N*	68	15	2.00	200			
KL732BTTE82N*	82						
KL732BTTE100*	100						

* Add tolerance character (B, C, G, J)

4. Dimensions and Construction

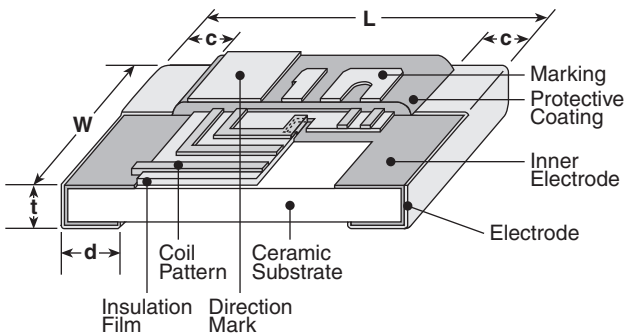

Type (Inch Size Code)	Dimensions inches (mm)				
	L	W	c	d	t
2B (1206)	.126 \pm .008 (3.2 \pm 0.2)	.063 \pm .008 (1.6 \pm 0.2)	.02 \pm .008 (0.5 \pm 0.2)	.016 ^{+.008} _{-.004} (0.4 ^{+0.2} _{-0.1})	.024 \pm .004 (0.6 \pm 0.1)

5. Marking

5-1 Coating and Marking Color

Coating color: Dark blue
Direction mark color: Yellow

5-2 Marking Method

Inductance value shall be indicated to two letters marking of significant figures. An alphabetical letter N shall replace position of decimal point.

(Example of marking)

2.2 \rightarrow 2.2nH
5.6 \rightarrow 5.6nH
10 \rightarrow 10nH
47 \rightarrow 47nH

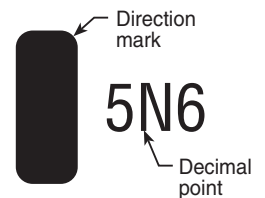

6. Characteristics

6-1 Test Condition

Unless otherwise specified, the standard range of atmospheric conditions for marking measurements and tests is as follows:

Ambient temperature: $20 \pm 15^\circ\text{C}$
Relative humidity: $65 \pm 20\%$

If there may be any doubt on results, measurements shall be made within the following limits:

Ambient temperature: $20 \pm 2^\circ\text{C}$
Relative humidity: $65 \pm 5\%$

6-2 Measurement Method of L and Q

Test equipment: Hewlett Packard RF Impedance analyzer 4191A
Fixture: Hewlett Packard Test fixture 16092A
Measuring frequency: 500 MHz/1.0nH ~ 22nH (1.0nH ~ 15nH)
200 MHz/27nH ~ 100nH (18nH ~ 27nH)

1. Perform auto-calibration to the HP4191A .275" (7mm) unknown connector connected to 0Ω/0S/50Ω standard terminations.
2. Connected the test fixture 16092A.
Measure the open circuit admittance (G_o , B_o), and the short circuit impedance (R_o , X_o).

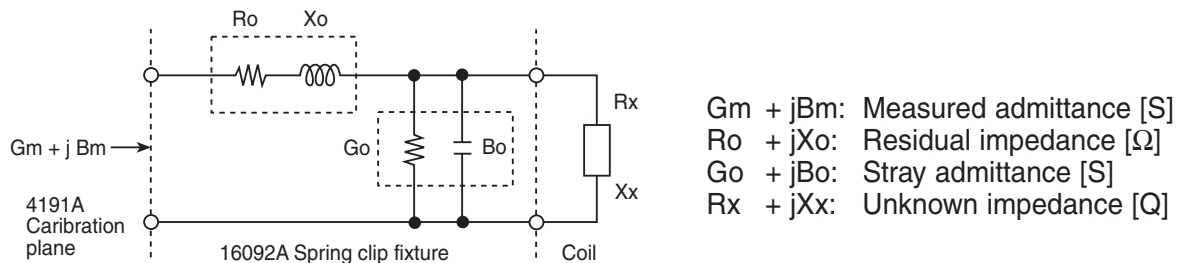

3. Set pattern up and ground side to direction mark on insulator.
Measure admittance (G_m , B_m).

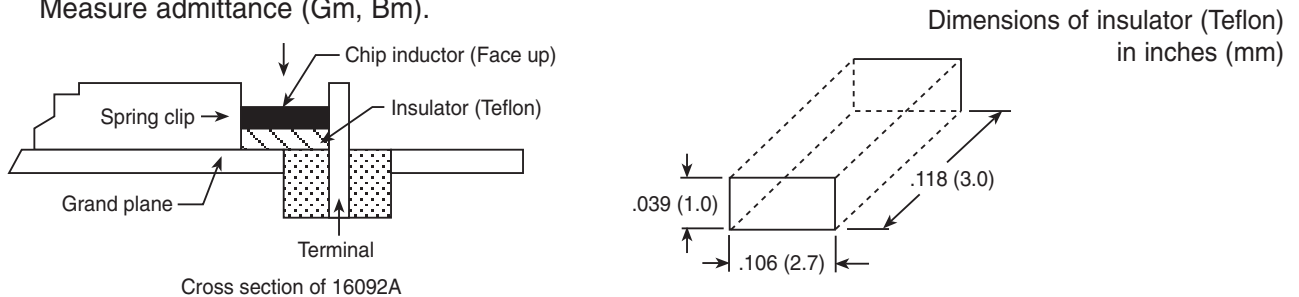

4. The L and Q value shall be given the following equation. (Compensated calculation)

$$R_x = \frac{G_m - G_o}{(G_m - G_o)^2 + (B_m - B_o)^2} - R_o$$

$$X_x = \frac{B_o - B_m}{(G_m - G_o)^2 + (B_m - B_o)^2} - X_o$$

$$L = \frac{X_x}{2\pi f}, \quad Q = \frac{X_x}{R_x}$$

L: Inductance of coil
Q: Quality factor of coil
f: Measuring frequency

6-3 Characteristics

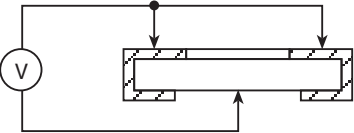
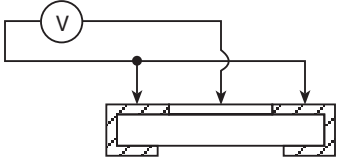
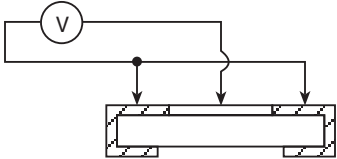
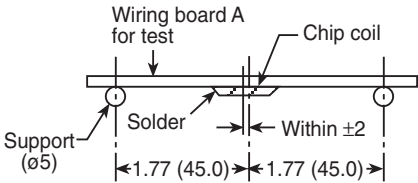
Item	Requirement	Test Method
Insulation resistance	More than 10^4 M Ω	DC 500V, 1 minute between both terminals and center of reverse side. 
	More than 10^3 M Ω	DC 500V, 1 minute Between both terminals and center of protection coating. 
Dielectric withstanding voltage	Without distinct damage	DC 500V, 1 minute Between both terminals and center of protection coating. 
Terminal strength	Δ R/R: Within $\pm 1\%$ Δ L/L: Within $\pm 2\%$ Δ Q/Q: Within $\pm 20\%$ No mechanical damage by cracks or stripping, etc.	Soldered chip on wiring board A for test is to be bent down to .118" (3 mm) as below drawing. (Set condition) Dimensions in inches (mm) 

6-3 Characteristics (continued)

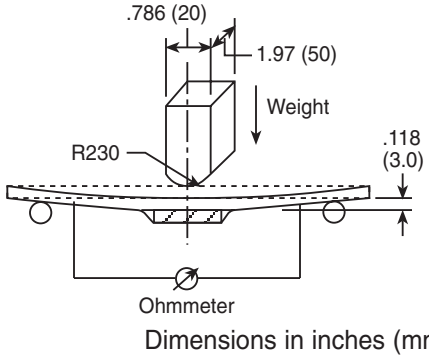
Item	Requirement	Test Method
		
Vibration	Δ L/L: Within $\pm 2\%$ Δ Q/Q: Within $\pm 20\%$ Without distinct damage in appearance and construction	Inflict 2 hours in each direction of X, Y, Z at vibration of 10 ~ 55Hz, amplitude .059 (1.5)
Resistance to solder heat	Δ L/L: Within $\pm 2\%$ Δ Q/Q: Within $\pm 20\%$ Without distinct damage in appearance and construction	$260 \pm 5^\circ\text{C}$, 10 ± 1 second
Solderability	95% of the terminal should be covered with new solder	$230 \pm 5^\circ\text{C}$, 3 ± 0.5 second
Shock resistance	Δ L/L: Within $\pm 2\%$ Δ Q/Q: Within $\pm 20\%$ Without distinct damage in appearance and construction	Inflict the impulse 3 times to both directions (total 18 times) along perpendicular axis that test condition 100G, 6 months
Low temperature operation	Δ L/L: Within $\pm 2\%$ Δ Q/Q: Within $\pm 20\%$ Without distinct damage in appearance and construction	$-40^\circ\text{C} \pm 3^\circ\text{C}$, $1,000 \pm 4$ hours
Heat resisting property	Δ L/L: Within $\pm 2\%$ Δ Q/Q: Within $\pm 20\%$ Without distinct damage in appearance and construction	$125^\circ\text{C} \pm 2^\circ\text{C}$, $1,000 \pm 4$ hours
Temperature cycling	Δ L/L: Within $\pm 2\%$ Δ Q/Q: Within $\pm 20\%$ Without distinct damage in appearance and construction	$-40 \pm 3^\circ\text{C}$, 30 minutes/ $125 \pm 2^\circ\text{C}$, 30 minutes 100 cycles

6-3 Characteristics (continued)

Item	Requirement	Test Method
Humidity	$\Delta L/L$: Within $\pm 2\%$ $\Delta Q/Q$: Within $\pm 20\%$ Without distinct damage in appearance and construction. Insulation resistance: more than $50M\Omega$	$40 \pm 2^\circ\text{C}$, 90 ~ 95% RH $1,000 \pm 4$ hours
Resistance to solvent	$\Delta L/L$: Within $\pm 2\%$ $\Delta Q/Q$: Within $\pm 20\%$ Without distinct damage in appearance, construction and marking	Immerse 30 ± 5 seconds in the reagent ($20 \sim 25^\circ\text{C}$) of JIS K 8839 (1995)

7. Packaging

7-1 Taping

The tapes for taping shall be embossed carrier tapes of .315" (8 mm) width and .157" (4 mm) pitches. The standard quantity per reel shall be 4,000 pieces.

(1) Dimensions of carrier tape

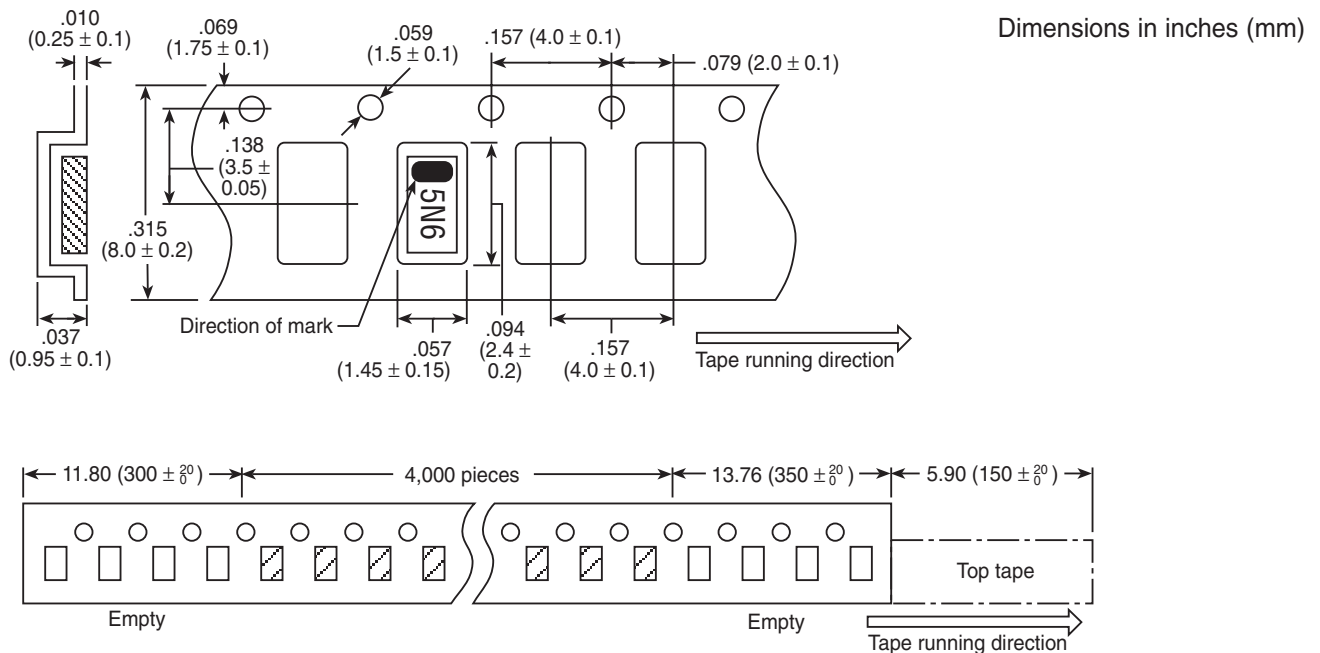

(2) Reel dimensions

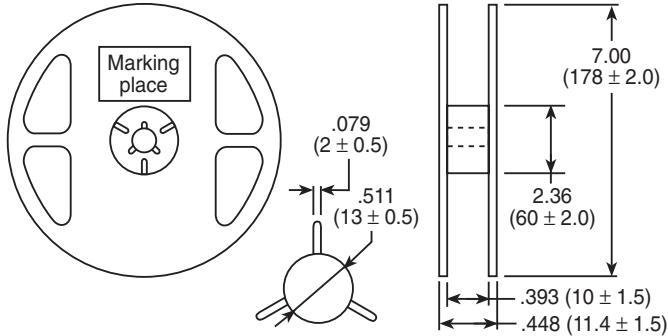

Dimensions in inches (mm)

(Marking item)

- (1) Type designation
- (2) Nominal inductance
- (3) Quantity
- (4) Production lot number
- (5) Manufacturer's name

8. Recommended Soldering Condition

8-1 Dimensions of Standard Land

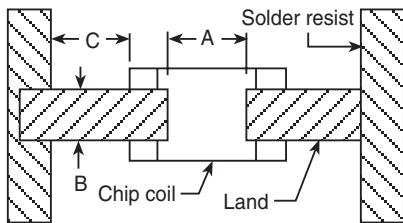

Dimensions in inches (mm)

Size	A	B	C
2B	.079 ~ .094 (2.0 ~ 2.4)	.047 ~ .063 (1.2 ~ 1.6)	.016 ~ .031 (0.4 ~ 0.8)

8-2 Soldering Condition

Reflow soldering should be done at 240°C within 20 seconds. Flow soldering should be done at 260°C within 10 seconds. Please use suitable solder quantity, too much solder may affect performance of product.

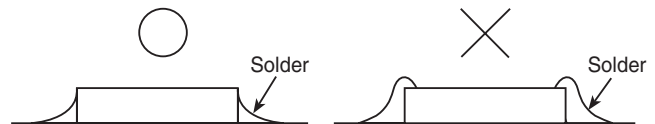

9. Recommended Washing Condition

Isopropyl alcohol and methyl alcohol used for the washing process will not affect the part performance. Ultrasonic cleaning should be changed to condition for size of printed wiring board and type of oscillator. Overpowering of ultrasonic cleaning will cause problems according to resonant phenomenon. Condition of ultrasonic cleaner should be confirmed prior to use.

We recommend the following conditions:

- Ultrasonic power: Within 20W/1
- Cleaning times: Within 5 minutes

10. Storage

Chip inductors should not be stored under high temperature and high humidity conditions. In particular, do not store **taping** where it is exposed to heat or direct sunlight. Otherwise, the packing material may be deformed, causing problems during mounting.