

The revision list can be viewed directly by clicking the title page.

The revision list summarizes the locations of revisions and additions. Details should always be checked by referring to the relevant text.

16

H8S/2628 Group Hardware Manual

Renesas 16-Bit Single-Chip Microcomputer
H8S Family/H8S/2600 Series

Keep safety first in your circuit designs!

1. Renesas Technology Corp. puts the maximum effort into making semiconductor products better and more reliable, but there is always the possibility that trouble may occur with them. Trouble with semiconductors may lead to personal injury, fire or property damage.
Remember to give due consideration to safety when making your circuit designs, with appropriate measures such as (i) placement of substitutive, auxiliary circuits, (ii) use of nonflammable material or (iii) prevention against any malfunction or mishap.

Notes regarding these materials

1. These materials are intended as a reference to assist our customers in the selection of the Renesas Technology Corp. product best suited to the customer's application; they do not convey any license under any intellectual property rights, or any other rights, belonging to Renesas Technology Corp. or a third party.
2. Renesas Technology Corp. assumes no responsibility for any damage, or infringement of any third-party's rights, originating in the use of any product data, diagrams, charts, programs, algorithms, or circuit application examples contained in these materials.
3. All information contained in these materials, including product data, diagrams, charts, programs and algorithms represents information on products at the time of publication of these materials, and are subject to change by Renesas Technology Corp. without notice due to product improvements or other reasons. It is therefore recommended that customers contact Renesas Technology Corp. or an authorized Renesas Technology Corp. product distributor for the latest product information before purchasing a product listed herein.
The information described here may contain technical inaccuracies or typographical errors.
Renesas Technology Corp. assumes no responsibility for any damage, liability, or other loss rising from these inaccuracies or errors.
Please also pay attention to information published by Renesas Technology Corp. by various means, including the Renesas Technology Corp. Semiconductor home page (<http://www.renesas.com>).
4. When using any or all of the information contained in these materials, including product data, diagrams, charts, programs, and algorithms, please be sure to evaluate all information as a total system before making a final decision on the applicability of the information and products. Renesas Technology Corp. assumes no responsibility for any damage, liability or other loss resulting from the information contained herein.
5. Renesas Technology Corp. semiconductors are not designed or manufactured for use in a device or system that is used under circumstances in which human life is potentially at stake. Please contact Renesas Technology Corp. or an authorized Renesas Technology Corp. product distributor when considering the use of a product contained herein for any specific purposes, such as apparatus or systems for transportation, vehicular, medical, aerospace, nuclear, or undersea repeater use.
6. The prior written approval of Renesas Technology Corp. is necessary to reprint or reproduce in whole or in part these materials.
7. If these products or technologies are subject to the Japanese export control restrictions, they must be exported under a license from the Japanese government and cannot be imported into a country other than the approved destination.
Any diversion or reexport contrary to the export control laws and regulations of Japan and/or the country of destination is prohibited.
8. Please contact Renesas Technology Corp. for further details on these materials or the products contained therein.

General Precautions on Handling of Product

1. Treatment of NC Pins

Note: Do not connect anything to the NC pins.

The NC (not connected) pins are either not connected to any of the internal circuitry or are used as test pins or to reduce noise. If something is connected to the NC pins, the operation of the LSI is not guaranteed.

2. Treatment of Unused Input Pins

Note: Fix all unused input pins to high or low level.

Generally, the input pins of CMOS products are high-impedance input pins. If unused pins are in their open states, intermediate levels are induced by noise in the vicinity, a pass-through current flows internally, and a malfunction may occur.

3. Processing before Initialization

Note: When power is first supplied, the product's state is undefined.

The states of internal circuits are undefined until full power is supplied throughout the chip and a low level is input on the reset pin. During the period where the states are undefined, the register settings and the output state of each pin are also undefined. Design your system so that it does not malfunction because of processing while it is in this undefined state. For those products which have a reset function, reset the LSI immediately after the power supply has been turned on.

4. Prohibition of Access to Undefined or Reserved Addresses

Note: Access to undefined or reserved addresses is prohibited.

The undefined or reserved addresses may be used to expand functions, or test registers may have been allocated to these addresses. Do not access these registers; the system's operation is not guaranteed if they are accessed.

Configuration of This Manual

This manual comprises the following items:

1. General Precautions on Handling of Product
2. Configuration of This Manual
3. Preface
4. Main Revisions in This Edition
5. Contents
6. Overview
7. Description of Functional Modules
 - CPU and System-Control Modules
 - On-Chip Peripheral Modules

The configuration of the functional description of each module differs according to the module. However, the generic style includes the following items:

- i) Feature
- ii) Input/Output Pin
- iii) Register Description
- iv) Operation
- v) Usage Note

When designing an application system that includes this LSI, take notes into account. Each section includes notes in relation to the descriptions given, and usage notes are given, as required, as the final part of each section.

8. List of Registers
9. Electrical Characteristics
10. Appendix

The list of revisions is a summary of points that have been revised or added to earlier versions. This does not include all of the revised contents. For details, see the actual locations in this manual.

11. Index

Preface

The H8S/2628 Group are single-chip microcomputers made up of the high-speed H8S/2600 CPU as its core, and the peripheral functions required to configure a system. The H8S/2600 CPU has an instruction set that is compatible with the H8/300 and H8/300H CPUs.

This LSI is equipped with a data transfer controller (DTC), ROM and RAM memory, a PC break controller (PBC), a 16-bit timer pulse unit (TPU), a programmable pulse generator (PPG), a watchdog timer (WDT), a serial communication interface (SCI), a controller area network (HCAN), a synchronous serial communication unit (SSU), an A/D converter, and I/O ports as on-chip peripheral modules required for system configuration. This LSI is suitable for use as an embedded microcomputer for high-level control systems. A single-power flash memory (F-ZTAT™) version is available for this LSI's ROM. This provides flexibility as it can be reprogrammed in no time to cope with all situations from the early stages of mass production to full-scale mass production. This is particularly applicable to application devices with specifications that will most probably change.

Note: * F-ZTAT is a trademark of Renesas Technology, Corp.

Target Users: This manual was written for users who will be using the H8S/2628 Group in the design of application systems. Target users are expected to understand the fundamentals of electrical circuits, logical circuits, and microcomputers.

Objective: This manual was written to explain the hardware functions and electrical characteristics of the H8S/2628 Group to the target users.
Refer to the H8S/2600 Series, H8S/2000 Series Programming Manual for a detailed description of the instruction set.

Notes on reading this manual:

- In order to understand the overall functions of the chip
Read the manual according to the contents. This manual can be roughly categorized into parts on the CPU, system control functions, peripheral functions and electrical characteristics.
- In order to understand the details of the CPU's functions
Read the H8S/2600 Series, H8S/2000 Series Programming Manual.
- In order to understand the details of a register when its name is known
Read the index that is the final part of the manual to find the page number of the entry on the register. The addresses, bits, and initial values of the registers are summarized in section 22, List of Registers.

Example: Register name: The following notation is used for cases when the same or a similar function, e.g. 16-bit timer pulse unit or serial communication, is implemented on more than one channel: XXX_N (XXX is the register name and N is the channel number)

Bit order: The MSB is on the left and the LSB is on the right.

Related Manuals: The latest versions of all related manuals are available from our web site. Please ensure you have the latest versions of all documents you require.
<http://www.renesas.com/>

H8S/2628 Group manuals:

Document Title	Document No.
H8S/2628 Group Hardware Manual	This manual
H8S/2600 Series, H8S/2000 Series Programming Manual	REJ09B0139

User's manuals for development tools:

Document Title	Document No.
H8S, H8/300 Series C/C++ Compiler, Assembler, Optimizing Linkage Editor User's Manual	REJ10B0058
H8S, H8/300 Series Simulator/Debugger User's Manual	ADE-702-037
H8S, H8/300 Series High-performance Embedded Workshop, High-performance Debugging Interface Tutorial	ADE-702-231
High-performance Embedded Workshop User's Manual	ADE-702-201

Main Revisions for This Edition

Item	Page	Revision (See Manual for Details)												
9.6.6 Pin Functions	148	Table 9.27 amended												
Table 9.27 PA2 Pin Function		<table border="1"> <thead> <tr> <th>RE in SCR_2</th> <th colspan="2">0</th> <th>1</th> </tr> </thead> <tbody> <tr> <td>PA2DDR</td> <td>0</td> <td>1</td> <td>—</td> </tr> <tr> <td>Pin function</td> <td>PA2 input</td> <td>PA2 output</td> <td>RxD2 input</td> </tr> </tbody> </table>	RE in SCR_2	0		1	PA2DDR	0	1	—	Pin function	PA2 input	PA2 output	RxD2 input
RE in SCR_2	0		1											
PA2DDR	0	1	—											
Pin function	PA2 input	PA2 output	RxD2 input											
10.4.5 PMW Modes	219	Description amended <ul style="list-style-type: none"> • PMW mode 2 (Before) ... clearing by a synchronization register compare match ... → (After) ... clearing by a duty cycle register compare match ...												
15.3 Register Descriptions	373	Description amended (Before) Local acceptance filter mask H (LAFMH) → (After) Local acceptance filter mask L (LAFML)												
	374	(Before) Local acceptance filter mask L (LAFML) → (After) Local acceptance filter mask H (LAFMH)												
15.3.1 Master Control Register (MCR)	375	Description deleted Reset Request ... [Setting condition] <ul style="list-style-type: none"> • 1-write (software reset) 												
15.3.2 General Status Register (GSR)	376	Description amended Transmit/Receive Warning Flag ... [Setting condition] <ul style="list-style-type: none"> • Third bit of Intermission after EOF (End of Frame) [Clearing condition] <ul style="list-style-type: none"> • When TEC < 96 and REC < 96 or TEC ≥ 256 (bus off state) 												
15.3.11 Interrupt Register (IRR)	387	Description amended Remote Frame Request Interrupt Flag ... in a mailbox (buffer), when MBIMR = 0 . ----- Receive Message Interrupt Flag ... received normally, when MBIMR = 0 .												

Item	Page	Revision (See Manual for Details)
15.3.16 Unread Message Status Register (UMSR)	393	<p>Description amended</p> <p>(Before) [Setting condition] • When a new message is received before RXPR is cleared</p> <p>[Clearing condition] • Writing 1</p> <p>The received message has been overwritten by a new message before being read. →</p> <p>(After) The received message has been overwritten by a new message before being read.</p> <p>[Setting condition] • When a new message is received before RXPR is cleared</p> <p>[Clearing condition] • Writing 1</p>
15.3.18 Message Control (MC15 to MC0)	397	<p>Description amended</p> <p>Data Length Code</p> <p>(Before) 1000: 8 bytes ... 1111: 8 bytes → (After) 1***: 8 bytes</p>
15.4.2 Initialization after Hardware Reset	403	<p>Figure 15.8 amended</p>
Table 15.3 Setting Range for TSEG1 and TSEG2 in BCR	404	<p>Note * amended</p> <p>Note: * Settable when bits BRP is not B'000000.</p>
15.8.10 HCAN TXCR Operation	420	<p>Description amended</p> <p>Conditions: • The HRxD pin is stacked to 1 because of ...</p> <p>Countermeasures: • Transmission must not be canceled ...</p> <p>Countermeasure: • A transmit wait message must be ...</p>
15.8.12 Canceling HCAN Reset and HCAN Sleep Mode	421	<p>Description amended</p> <p>... reset for HCAN or HCAN sleep mode (MCR0 = 0 or MCR5 = 0), confirm that ...</p>
Section 16 Synchronous Serial Communication Unit (SSU)	423	<p>Description deleted</p> <p>... different clock polarity and clock phase. Figure 16.1 is a ...</p>
16.3.6 SS transmit Data Register 3 to 0 (SSTDR3 to SSTDR0)	433	<p>Description amended</p> <p>... SSTDR0 are valid. Do not attempt to access invalid SS transmit data registers. When the SSU detects ...</p>

Item	Page	Revision (See Manual for Details)
16.3.7 SS Receive Data Register 3 to 0 (SSRDR3 to SSRDR0)	434	Description amended ... SSRDR0 are valid. Do not attempt to access invalid SS receive data registers. When the SSU has received ...
16.4.4 Data Transmission and Data Reception Figure 16.4 Example of SSU Initialization	437	Figure 16.4 amended <div style="border: 1px solid black; padding: 10px; margin: 10px 0;"> <p>[4] Specify TE, RE, TEIE, TIE, RIE, and CEIE bits simultaneously</p> </div> <div style="border: 1px solid black; border-radius: 15px; padding: 5px; margin: 10px 0; text-align: center;">End</div>
	438	Description amended Data Transmission (Before) ... data to SSTDR after the TE bit in SSER is set to 1 clears the TDRE bit in SSSR to 0, and the SSTDR contents is transferred to SSTRSR. → (After) ... data to SSTDR after initialization of the SSU automatically clears the TDRE bit in SSSR to 0, and the contents of SSTDR is transferred to SSTRSR.
Figure 16.6 Example of Data Transmission Flowchart	440	Figure 16.6 amended <div style="border: 1px solid black; border-radius: 15px; padding: 5px; margin: 10px 0; text-align: center;">Start</div> <div style="border: 1px solid black; padding: 5px; margin: 5px 0;">[1] Initialization</div> <div style="border: 1px solid black; padding: 5px; margin: 5px 0;">[2] Read TDRE in SSR</div>
	441	Description amended Data Reception (Before) ... After the SSU sets the RE bit in SSER to 1 and dummy-reads SSRDR, data ... → (After) ... After initialization, the SSU dummy-reads SSRDR and data ...

16.4.4 Data Transmission and Data Reception

Figure 16.7 Example of Reception Operation

Figure 16.7 amended

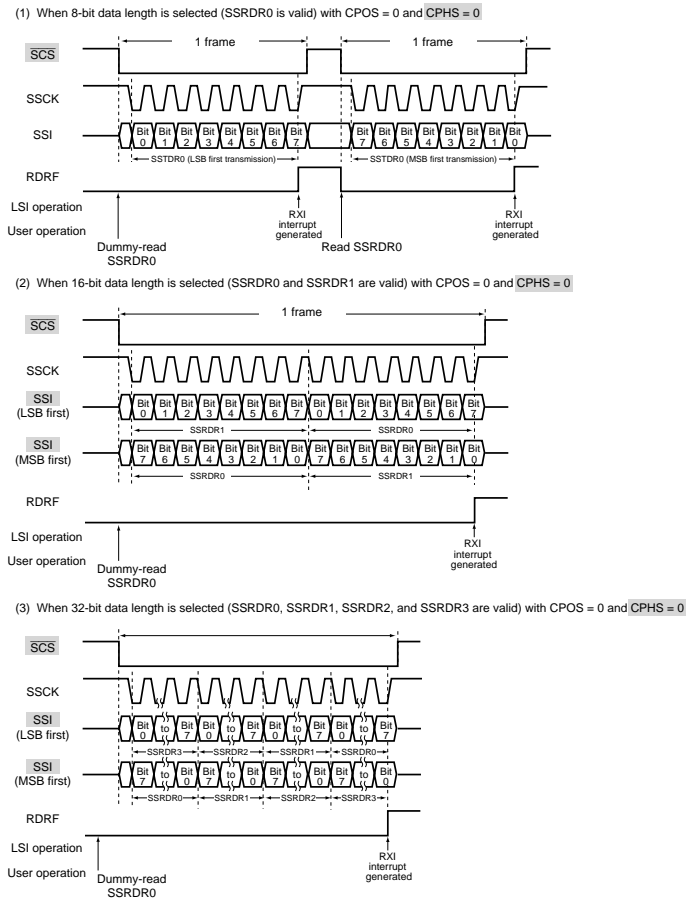
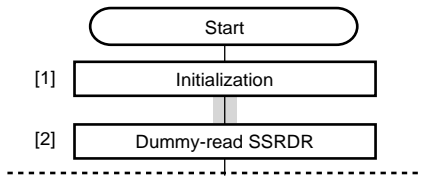

Figure 16.8 Example of Data Reception Flowchart

Figure 16.8 amended



Item	Page	Revision (See Manual for Details)
------	------	-----------------------------------

16.4.4 Data Transmission and Data Reception

445

Figure 16.9 amended

Figure 16.9 Example of Simultaneous Transmission/ Reception Flowchart

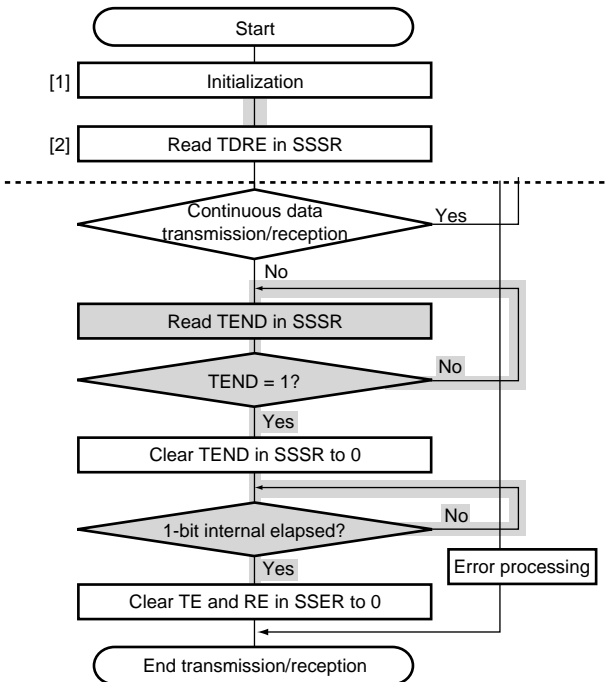

Note: Hatching boxes represent SSU internal operations.

16.4.5 \overline{SCS} pin Control and Conflict Error

446

Description amended

(Before) ... (Hi-Z) to detect arbitration. The arbitration detection period ... → (After) ... (Hi-Z) to detect conflict error. The conflict detection period ...

Figure 16.10 Conflict Error Detection Timing (Before Transfer Start)

Figure 16.10 amended

(Before) Arbitration detection period → (After) Conflict error detection period

Figure 16.11 Conflict Error Detection Timing (After Transfer End)

447

Figure 16.11 amended

(Before) Arbitration detection period → (After) Conflict error detection period

Item **Page** **Revision (See Manual for Details)**

Section 21 Power-Down Modes 503

Table 21.2 amended

Table 21.2 LSI Internal States in Each Mode

Function		High-Speed	Medium-Speed	Sleep	Module Stop	Software Standby	Hardware Standby
Peripheral functions	SCI	Operate	Operate	Operate	Halted (reset/retained)	Halted (reset)	Halted (reset)
	HCAN						
	A/D						

Note * amended

Notes: ... has been, made are halted (reset or retained).

* The SCI's TDR, RDR, and SSR are halted (reset), and the other registers are halted (retained).

22.3 Register States in Each Operating Mode 571, 572

Table amended

Register Abbreviation	Reset	High Speed	Medium Speed	Sleep	Module Stop	Software Standby	Hardware Standby	Module
SMR_0	Initialized	—	—	—	■	■	Initialized	SCI_0
BRR_0	Initialized	—	—	—	■	■	Initialized	
SCR_0	Initialized	—	—	—	■	■	Initialized	
TDR_0	Initialized	—	—	—	Initialized	Initialized	Initialized	
SSR_0	Initialized	—	—	—	Initialized	Initialized	Initialized	
RDR_0	Initialized	—	—	—	Initialized	Initialized	Initialized	
SCMR_0	Initialized	—	—	—	■	■	Initialized	
SMR_2	Initialized	—	—	—	■	■	Initialized	SCI_2
BRR_2	Initialized	—	—	—	■	■	Initialized	
SCR_2	Initialized	—	—	—	■	■	Initialized	
TDR_2	Initialized	—	—	—	Initialized	Initialized	Initialized	
SSR_2	Initialized	—	—	—	Initialized	Initialized	Initialized	
RDR_2	Initialized	—	—	—	Initialized	Initialized	Initialized	
SCMR_2	Initialized	—	—	—	■	■	Initialized	

Section 23 Electrical Characteristics 573 to 592 “Preliminary” deleted

Appendix C Package Dimensions 594

Figure C.1 replaced

Figure C.1 FP-100M Package Dimensions

Contents

Section 1 Overview.....	1
1.1 Overview.....	1
1.2 Internal Block Diagram.....	2
1.3 Pin Arrangement.....	3
1.4 Pin Functions	4
Section 2 CPU	11
2.1 Features.....	11
2.1.1 Differences between H8S/2600 CPU and H8S/2000 CPU	12
2.1.2 Differences from H8/300 CPU	13
2.1.3 Differences from H8/300H CPU	13
2.2 CPU Operating Modes.....	14
2.2.1 Normal Mode.....	14
2.2.2 Advanced Mode.....	15
2.3 Address Space.....	18
2.4 Registers	19
2.4.1 General Registers.....	20
2.4.2 Program Counter (PC).....	21
2.4.3 Extended Control Register (EXR)	21
2.4.4 Condition-Code Register (CCR).....	22
2.4.5 Multiply-Accumulate Register (MAC).....	23
2.4.6 Initial Values of CPU Registers.....	23
2.5 Data Formats.....	24
2.5.1 General Register Data Formats.....	24
2.5.2 Memory Data Formats.....	26
2.6 Instruction Set.....	27
2.6.1 Table of Instructions Classified by Function	28
2.6.2 Basic Instruction Formats	38
2.7 Addressing Modes and Effective Address Calculation.....	39
2.7.1 Register Direct—Rn	40
2.7.2 Register Indirect—@ERn.....	40
2.7.3 Register Indirect with Displacement—@(d:16, ERn) or @(d:32, ERn).....	40
2.7.4 Register Indirect with Post-Increment or Pre-Decrement—@ERn+ or @-ERn..	41
2.7.5 Absolute Address—@aa:8, @aa:16, @aa:24, or @aa:32	41
2.7.6 Immediate—#xx:8, #xx:16, or #xx:32.....	42
2.7.7 Program-Counter Relative—@(d:8, PC) or @(d:16, PC)	42
2.7.8 Memory Indirect—@@aa:8	42
2.7.9 Effective Address Calculation	43

2.8	Processing States	46
2.9	Usage Note	47
2.9.1	Notes on Using the Bit Operation Instruction.....	47
Section 3 MCU Operating Modes		49
3.1	Operating Mode Selection	49
3.2	Register Descriptions.....	49
3.2.1	Mode Control Register (MDCR)	50
3.2.2	System Control Register (SYSCR).....	51
3.3	Pin Functions in Each Operating Mode	52
3.4	Address Map.....	53
Section 4 Exception Handling		55
4.1	Exception Handling Types and Priority	55
4.2	Exception Sources and Exception Vector Table	55
4.3	Reset	57
4.3.1	Reset Exception Handling	57
4.3.2	Interrupts after Reset.....	59
4.3.3	State of On-Chip Peripheral Modules after Reset Release	60
4.4	Traces.....	60
4.5	Interrupts.....	61
4.6	Trap Instruction	62
4.7	Stack Status after Exception Handling.....	63
4.8	Usage Note	64
Section 5 Interrupt Controller		65
5.1	Features.....	65
5.2	Input/Output Pins.....	67
5.3	Register Descriptions.....	67
5.3.1	Interrupt Priority Registers A to M (IPRA to IPRM)	68
5.3.2	IRQ Enable Register (IER).....	69
5.3.3	IRQ Sense Control Registers H and L (ISCRH, ISCRL).....	70
5.3.4	IRQ Status Register (ISR).....	72
5.4	Interrupt Sources.....	73
5.4.1	External Interrupts	73
5.4.2	Internal Interrupts	74
5.5	Interrupt Exception Handling Vector Table.....	74
5.6	Interrupt Control Modes and Interrupt Operation.....	78
5.6.1	Interrupt Control Mode 0.....	78
5.6.2	Interrupt Control Mode 2.....	80
5.6.3	Interrupt Exception Handling Sequence	81

5.6.4	Interrupt Response Times	83
5.6.5	DTC Activation by Interrupt.....	84
5.7	Usage Notes	84
5.7.1	Conflict between Interrupt Generation and Disabling	84
5.7.2	Instructions that Disable Interrupts.....	85
5.7.3	When Interrupts Are Disabled	85
5.7.4	Interrupts during Execution of EEPMOV Instruction	86
5.7.5	IRQ Interrupt	86
Section 6 PC Break Controller (PBC).....		87
6.1	Features.....	87
6.2	Register Descriptions.....	88
6.2.1	Break Address Register A (BARA).....	88
6.2.2	Break Address Register B (BARB)	89
6.2.3	Break Control Register A (BCRA).....	89
6.2.4	Break Control Register B (BCRB)	90
6.3	Operation	90
6.3.1	PC Break Interrupt Due to Instruction Fetch	90
6.3.2	PC Break Interrupt Due to Data Access	91
6.3.3	PC Break Operation at Consecutive Data Transfer	91
6.3.4	Operation in Transitions to Power-Down Modes	91
6.3.5	When Instruction Execution Is Delayed by One State.....	92
6.4	Usage Notes	93
6.4.1	Module Stop Mode Setting.....	93
6.4.2	PC Break Interrupts	93
6.4.3	CMFA and CMFB	93
6.4.4	PC Break Interrupt when DTC Is Bus Master	93
6.4.5	PC Break Set for Instruction Fetch at Address Following BSR, JSR, JMP, TRAPA, RTE, or RTS Instruction.....	93
6.4.6	I Bit Set by LDC, ANDC, ORC, or XORC Instruction	93
6.4.7	PC Break Set for Instruction Fetch at Address Following Bcc Instruction.....	94
6.4.8	PC Break Set for Instruction Fetch at Branch Destination Address of Bcc Instruction.....	94
Section 7 Bus Controller		95
7.1	Basic Timing.....	95
7.1.1	On-Chip Memory Access Timing (ROM, RAM).....	95
7.1.2	On-Chip Support Module Access Timing	96
7.1.3	On-Chip HCAN Module Access Timing.....	97
7.1.4	On-Chip SSU Module and Realtime Input Port Data Register Access Timing...	98
7.2	Bus Arbitration	99

7.2.1	Order of Priority of the Bus Masters.....	99
7.2.2	Bus Transfer Timing.....	99
Section 8 Data Transfer Controller (DTC).....		101
8.1	Features.....	101
8.2	Register Descriptions.....	103
8.2.1	DTC Mode Register A (MRA)	104
8.2.2	DTC Mode Register B (MRB).....	105
8.2.3	DTC Source Address Register (SAR).....	105
8.2.4	DTC Destination Address Register (DAR).....	105
8.2.5	DTC Transfer Count Register A (CRA)	105
8.2.6	DTC Transfer Count Register B (CRB).....	106
8.2.7	DTC Enable Registers (DTCER).....	106
8.2.8	DTC Vector Register (DTVECR).....	107
8.3	Activation Sources.....	108
8.4	Location of Register Information and DTC Vector Table	109
8.5	Operation	112
8.5.1	Normal Mode.....	113
8.5.2	Repeat Mode.....	114
8.5.3	Block Transfer Mode.....	115
8.5.4	Chain Transfer	117
8.5.5	Interrupts.....	118
8.5.6	Operation Timing.....	118
8.5.7	Number of DTC Execution States	119
8.6	Procedures for Using DTC	121
8.6.1	Activation by Interrupt	121
8.6.2	Activation by Software	121
8.7	Examples of Use of the DTC.....	122
8.7.1	Normal Mode.....	122
8.7.2	Chain Transfer	123
8.7.3	Software Activation	124
8.8	Usage Notes.....	125
8.8.1	Module Stop Mode Setting	125
8.8.2	On-Chip RAM	125
8.8.3	DTCE Bit Setting.....	125
Section 9 I/O Ports.....		127
9.1	Port 1.....	131
9.1.1	Port 1 Data Direction Register (P1DDR).....	131
9.1.2	Port 1 Data Register (P1DR)	132
9.1.3	Port 1 Register (PORT1)	132

9.1.4	Pin Functions	133
9.2	Port 3.....	136
9.2.1	Port 3 Data Direction Register (P3DDR).....	136
9.2.2	Port 3 Data Register (P3DR)	137
9.2.3	Port 3 Register (PORT3)	137
9.2.4	Port 3 Open-Drain Control Register (P3ODR)	138
9.2.5	Pin Functions	138
9.3	Port 4.....	140
9.3.1	Port 4 Register (PORT4)	140
9.4	Port 7.....	140
9.4.1	Port 7 Data Direction Register (P7DDR).....	141
9.4.2	Port 7 Data Register (P7DR)	141
9.4.3	Port 7 Register (PORT7)	142
9.4.4	Pin Functions	142
9.5	Port 9.....	144
9.5.1	Port 9 Register (PORT9)	144
9.6	Port A.....	145
9.6.1	Port A Data Direction Register (PADDR).....	145
9.6.2	Port A Data Register (PADR).....	146
9.6.3	Port A Register (PORTA).....	146
9.6.4	Port A Pull-Up MOS Control Register (PAPCR).....	147
9.6.5	Port A Open-Drain Control Register (PAODR)	147
9.6.6	Pin Functions	148
9.7	Port B.....	149
9.7.1	Port B Data Direction Register (PBDDR)	149
9.7.2	Port B Data Register (PBDR)	150
9.7.3	Port B Register (PORTB)	150
9.7.4	Port B Pull-Up MOS Control Register (PBPCR)	151
9.7.5	Port B Open-Drain Control Register (PBODR).....	151
9.7.6	Pin Functions	152
9.8	Port C.....	154
9.8.1	Port C Data Direction Register (PCDDR)	154
9.8.2	Port C Data Register (PCDR)	155
9.8.3	Port C Register (PORTC)	155
9.8.4	Port C Pull-Up MOS Control Register (PCPCR)	156
9.8.5	Port C Open-Drain Control Register (PCODR).....	156
9.8.6	Pin Functions	157
9.9	Port D.....	160
9.9.1	Port D Data Direction Register (PDDDR).....	160
9.9.2	Port D Data Register (PDDR).....	161
9.9.3	Port D Register (PORTD).....	161

9.9.4	Port D Pull-Up MOS Control Register (PDPCR).....	162
9.9.5	Port D RealTime Input Data Register (PDRTIDR)	162
9.10	Port F	163
9.10.1	Port F Data Direction Register (PFDDR)	163
9.10.2	Port F Data Register (PFDR)	164
9.10.3	Port F Register (PORTF)	164
9.10.4	Pin Functions	165
Section 10	16-Bit Timer Pulse Unit (TPU).....	167
10.1	Features.....	167
10.2	Input/Output Pins	171
10.3	Register Descriptions.....	172
10.3.1	Timer Control Register (TCR).....	174
10.3.2	Timer Mode Register (TMDR).....	179
10.3.3	Timer I/O Control Register (TIOR).....	181
10.3.4	Timer Interrupt Enable Register (TIER).....	198
10.3.5	Timer Status Register (TSR).....	200
10.3.6	Timer Counter (TCNT).....	203
10.3.7	Timer General Register (TGR)	203
10.3.8	Timer Start Register (TSTR)	203
10.3.9	Timer Synchro Register (TSYR)	204
10.4	Operation	205
10.4.1	Basic Functions.....	205
10.4.2	Synchronous Operation	211
10.4.3	Buffer Operation.....	212
10.4.4	Cascaded Operation	217
10.4.5	PWM Modes.....	219
10.4.6	Phase Counting Mode.....	224
10.5	Interrupt Sources.....	231
10.6	DTC Activation	233
10.7	A/D Converter Activation.....	233
10.8	Operation Timing.....	234
10.8.1	Input/Output Timing.....	234
10.8.2	Interrupt Signal Timing	237
10.9	Usage Notes	241
10.9.1	Module Stop Mode Setting	241
10.9.2	Input Clock Restrictions	241
10.9.3	Caution on Period Setting	242
10.9.4	Conflict between TCNT Write and Clear Operations	242
10.9.5	Conflict between TCNT Write and Increment Operations	243
10.9.6	Conflict between TGR Write and Compare Match	244

10.9.7	Conflict between Buffer Register Write and Compare Match.....	245
10.9.8	Conflict between TGR Read and Input Capture	246
10.9.9	Conflict between TGR Write and Input Capture	247
10.9.10	Conflict between Buffer Register Write and Input Capture.....	248
10.9.11	Conflict between Overflow/Underflow and Counter Clearing	249
10.9.12	Conflict between TCNT Write and Overflow/Underflow	250
10.9.13	Multiplexing of I/O Pins	250
10.9.14	Interrupts in Module Stop Mode.....	250
Section 11	8-Bit Timers.....	251
11.1	Features.....	251
11.2	Input/Output Pins.....	253
11.3	Register Descriptions.....	253
11.3.1	Timer Counters (TCNT).....	254
11.3.2	Time Constant Registers A (TCORA).....	254
11.3.3	Time Constant Registers B (TCORB)	254
11.3.4	Timer Control Registers (TCR)	255
11.3.5	Timer Control/Status Registers (TCSR).....	257
11.4	Operation	262
11.4.1	Pulse Output	262
11.5	Operation Timing.....	263
11.5.1	TCNT Incrementation Timing	263
11.5.2	Timing of CMFA and CMFB Setting When a Compare-Match Occurs	264
11.5.3	Timing of Timer Output When a Compare-Match Occurs	264
11.5.4	Timing of Compare-Match Clear When a Compare-Match Occurs	265
11.5.5	TCNT External Reset Timing	265
11.5.6	Timing of Overflow Flag (OVF) Setting	266
11.6	Operation with Cascaded Connection.....	267
11.6.1	16-Bit Count Mode	267
11.6.2	Compare-Match Count Mode	267
11.7	Interrupt Sources.....	268
11.7.1	Interrupt Sources and DTC Activation	268
11.7.2	A/D Converter Activation.....	268
11.8	Usage Notes	269
11.8.1	Conflict between TCNT Write and Clear	269
11.8.2	Conflict between TCNT Write and Increment.....	270
11.8.3	Conflict between TCOR Write and Compare-Match.....	271
11.8.4	Conflict between Compare-Matches A and B	271
11.8.5	Switching of Internal Clocks and TCNT Operation	272
11.8.6	Conflict between Interrupts and Module Stop Mode.....	273
11.8.7	Notes on Cascaded Connection	273

Section 12	Programmable Pulse Generator (PPG)	275
12.1	Features	275
12.2	Input/Output Pins	277
12.3	Register Descriptions	277
12.3.1	Next Data Enable Registers H, L (NDERH, NDERL)	278
12.3.2	Output Data Registers H, L (PODRH, PODRL)	279
12.3.3	Next Data Registers H, L (NDRH, NDRL)	280
12.3.4	PPG Output Control Register (PCR)	282
12.3.5	PPG Output Mode Register (PMR)	283
12.4	Operation	284
12.4.1	Overview	284
12.4.2	Output Timing	285
12.4.3	Sample Setup Procedure for Normal Pulse Output	286
12.4.4	Example of Normal Pulse Output (Example of Five-Phase Pulse Output)	287
12.4.5	Non-Overlapping Pulse Output	288
12.4.6	Sample Setup Procedure for Non-Overlapping Pulse Output	290
12.4.7	Example of Non-Overlapping Pulse Output (Example of Four-Phase Complementary Non-Overlapping Output)	291
12.4.8	Inverted Pulse Output	293
12.4.9	Pulse Output Triggered by Input Capture	294
12.5	Usage Notes	294
12.5.1	Module Stop Mode Setting	294
12.5.2	Operation of Pulse Output Pins	294
Section 13	Watchdog Timer	295
13.1	Features	295
13.2	Register Descriptions	296
13.2.1	Timer Counter (TCNT)	296
13.2.2	Timer Control/Status Register (TCSR)	297
13.2.3	Reset Control/Status Register (RSTCSR)	299
13.3	Operation	300
13.3.1	Watchdog Timer Mode Operation	300
13.3.2	Interval Timer Mode	300
13.4	Interrupts	301
13.5	Usage Notes	301
13.5.1	Notes on Register Access	301
13.5.2	Conflict between Timer Counter (TCNT) Write and Increment	302
13.5.3	Changing Value of CKS2 to CKS0	303
13.5.4	Switching between Watchdog Timer Mode and Interval Timer Mode	303
13.5.5	Internal Reset in Watchdog Timer Mode	303
13.5.6	OVF Flag Clearing in Interval Timer Mode	303

Section 14	Serial Communication Interface (SCI)	305
14.1	Features	305
14.2	Input/Output Pins	307
14.3	Register Descriptions	307
14.3.1	Receive Shift Register (RSR)	308
14.3.2	Receive Data Register (RDR)	308
14.3.3	Transmit Data Register (TDR)	308
14.3.4	Transmit Shift Register (TSR)	308
14.3.5	Serial Mode Register (SMR)	309
14.3.6	Serial Control Register (SCR)	313
14.3.7	Serial Status Register (SSR)	316
14.3.8	Smart Card Mode Register (SCMR)	322
14.3.9	Bit Rate Register (BRR)	323
14.4	Operation in Asynchronous Mode	330
14.4.1	Data Transfer Format	330
14.4.2	Receive Data Sampling Timing and Reception Margin in Asynchronous Mode	332
14.4.3	Clock	333
14.4.4	SCI Initialization (Asynchronous Mode)	334
14.4.5	Data Transmission (Asynchronous Mode)	335
14.4.6	Serial Data Reception (Asynchronous Mode)	337
14.5	Multiprocessor Communication Function	341
14.5.1	Multiprocessor Serial Data Transmission	342
14.5.2	Multiprocessor Serial Data Reception	343
14.6	Operation in Clocked Synchronous Mode	347
14.6.1	Clock	347
14.6.2	SCI Initialization (Clocked Synchronous Mode)	348
14.6.3	Serial Data Transmission (Clocked Synchronous Mode)	349
14.6.4	Serial Data Reception (Clocked Synchronous Mode)	352
14.6.5	Simultaneous Serial Data Transmission and Reception (Clocked Synchronous Mode)	354
14.7	Operation in Smart Card Interface	356
14.7.1	Pin Connection Example	356
14.7.2	Data Format (Except for Block Transfer Mode)	357
14.7.3	Block Transfer Mode	359
14.7.4	Receive Data Sampling Timing and Reception Margin in Smart Card Interface Mode	359
14.7.5	Initialization	360
14.7.6	Data Transmission (Except for Block Transfer Mode)	361
14.7.7	Serial Data Reception (Except for Block Transfer Mode)	364
14.7.8	Clock Output Control	366
14.8	Interrupt Sources	368

14.8.1	Interrupts in Normal Serial Communication Interface Mode	368
14.8.2	Interrupts in Smart Card Interface Mode	369
14.9	Usage Notes	370
14.9.1	Module Stop Mode Setting	370
14.9.2	Break Detection and Processing	370
14.9.3	Mark State and Break Detection	370
14.9.4	Receive Error Flags and Transmit Operations (Clocked Synchronous Mode Only)	370
Section 15 Controller Area Network (HCAN)		371
15.1	Features	371
15.2	Input/Output Pins	373
15.3	Register Descriptions	373
15.3.1	Master Control Register (MCR)	374
15.3.2	General Status Register (GSR)	375
15.3.3	Bit Configuration Register (BCR)	377
15.3.4	Mailbox Configuration Register (MBCR)	379
15.3.5	Transmit Wait Register (TXPR)	380
15.3.6	Transmit Wait Cancel Register (TXCR)	381
15.3.7	Transmit Acknowledge Register (TXACK)	382
15.3.8	Abort Acknowledge Register (ABACK)	383
15.3.9	Receive Complete Register (RXPR)	384
15.3.10	Remote Request Register (RFPR)	385
15.3.11	Interrupt Register (IRR)	386
15.3.12	Mailbox Interrupt Mask Register (MBIMR)	390
15.3.13	Interrupt Mask Register (IMR)	391
15.3.14	Receive Error Counter (REC)	392
15.3.15	Transmit Error Counter (TEC)	392
15.3.16	Unread Message Status Register (UMSR)	393
15.3.17	Local Acceptance Filter Masks (LAFML, LAFMH)	394
15.3.18	Message Control (MC15 to MC0)	396
15.3.19	Message Data (MD15 to MD0)	398
15.3.20	HCAN Monitor Register (HCANMON)	399
15.4	Operation	400
15.4.1	Hardware and Software Resets	400
15.4.2	Initialization after Hardware Reset	400
15.4.3	Message Transmission	405
15.4.4	Message Reception	409
15.4.5	HCAN Sleep Mode	412
15.4.6	HCAN Halt Mode	415
15.5	Interrupt Sources	416

15.6	DTC Interface	417
15.7	CAN Bus Interface	418
15.8	Usage Notes	418
15.8.1	Module Stop Mode Setting	418
15.8.2	Reset	418
15.8.3	HCAN Sleep Mode	419
15.8.4	Interrupts	419
15.8.5	Error Counters	419
15.8.6	Register Access	419
15.8.7	HCAN Medium-Speed Mode	419
15.8.8	Register Hold in Standby Modes	419
15.8.9	Use on Bit Manipulation Instructions	419
15.8.10	HCAN TXCR Operation	420
15.8.11	HCAN Transmit Procedure	421
15.8.12	Canceling HCAN Reset and HCAN Sleep Mode	421
15.8.13	Accessing Mailbox in HCAN Sleep Mode	421
Section 16 Synchronous Serial Communication Unit (SSU)		423
16.1	Features	423
16.2	Input/Output Pins	425
16.3	Register Descriptions	425
16.3.1	SS Control Register H (SSCRH)	426
16.3.2	SS Control Register L (SSCRL)	428
16.3.3	SS Mode Register (SSMR)	429
16.3.4	SS Enable Register (SSER)	430
16.3.5	SS Status Register (SSSR)	431
16.3.6	SS Transmit Data Register 3 to 0 (SSTDR3 to SSTDR0)	433
16.3.7	SS Receive Data Register 3 to 0 (SSRDR3 to SSRDR0)	434
16.3.8	SS Shift Register (SSTRSR)	434
16.4	Operation	435
16.4.1	Transfer Clock	435
16.4.2	Relationship of Clock Phase, Polarity, and Data	435
16.4.3	Relationship between Data I/O Pins and the Shift Register	436
16.4.4	Data Transmission and Data Reception	437
16.4.5	SCS Pin Control and Conflict Error	446
16.5	Interrupt Requests	447
16.6	Usage Note	448
16.6.1	Setting of Module Stop Mode	448
Section 17 A/D Converter		449
17.1	Features	449

17.2	Input/Output Pins	451
17.3	Register Description	452
17.3.1	A/D Data Registers A to D (ADDRA to ADDRD)	452
17.3.2	A/D Control/Status Register (ADCSR)	453
17.3.3	A/D Control Register (ADCR)	455
17.4	Operation	456
17.4.1	Single Mode.....	456
17.4.2	Scan Mode	456
17.4.3	Input Sampling and A/D Conversion Time	457
17.4.4	External Trigger Input Timing.....	459
17.5	Interrupt Source	459
17.6	A/D Conversion Accuracy Definitions	460
17.7	Usage Notes.....	462
17.7.1	Module Stop Mode Setting	462
17.7.2	Permissible Signal Source Impedance.....	462
17.7.3	Influences on Absolute Accuracy	462
17.7.4	Range of Analog Power Supply and Other Pin Settings.....	463
17.7.5	Notes on Board Design.....	463
17.7.6	Notes on Noise Countermeasures.....	463
Section 18	RAM.....	465
Section 19	ROM.....	467
19.1	Features.....	467
19.2	Mode Transitions	468
19.3	Block Configuration	472
19.4	Input/Output Pins.....	473
19.5	Register Descriptions.....	473
19.5.1	Flash Memory Control Register 1 (FLMCR1)	473
19.5.2	Flash Memory Control Register 2 (FLMCR2)	475
19.5.3	Erase Block Register 1 (EBR1)	475
19.5.4	Erase Block Register 2 (EBR2)	476
19.5.5	RAM Emulation Register (RAMER).....	476
19.6	On-Board Programming Modes.....	477
19.6.1	Boot Mode	478
19.6.2	Programming/Erasing in User Program Mode.....	480
19.7	Flash Memory Emulation in RAM	482
19.8	Flash Memory Programming/Erasing.....	484
19.8.1	Program/Program-Verify	484
19.8.2	Erase/Erase-Verify.....	486
19.8.3	Interrupt Handling when Programming/Erasing Flash Memory.....	486

19.9	Program/Erase Protection	488
19.9.1	Hardware Protection	488
19.9.2	Software Protection	488
19.9.3	Error Protection	488
19.10	Programmer Mode	489
19.11	Power-Down States for Flash Memory.....	489
19.12	Note on Switching from F-ZTAT Version to Masked ROM Version	490
Section 20 Clock Pulse Generator		491
20.1	Register Descriptions.....	492
20.1.1	System Clock Control Register (SCKCR)	492
20.1.2	Low-Power Control Register (LPWRCR)	493
20.2	Oscillator	494
20.2.1	Connecting a Crystal Resonator	494
20.2.2	External Clock Input.....	495
20.3	PLL Circuit	497
20.4	Medium-Speed Clock Divider	497
20.5	Bus Master Clock Selection Circuit.....	497
20.6	Usage Notes	498
20.6.1	Note on Crystal Resonator.....	498
20.6.2	Note on Board Design.....	498
Section 21 Power-Down Modes.....		501
21.1	Register Descriptions.....	504
21.1.1	Standby Control Register (SBYCR)	504
21.1.2	Module Stop Control Registers A to C (MSTPCRA to MSTPCRC)	506
21.2	Medium-Speed Mode	507
21.3	Sleep Mode	508
21.3.1	Transition to Sleep Mode.....	508
21.3.2	Clearing Sleep Mode	508
21.4	Software Standby Mode.....	509
21.4.1	Transition to Software Standby Mode	509
21.4.2	Clearing Software Standby Mode.....	509
21.4.3	Setting Oscillation Stabilization Time after Clearing Software Standby Mode... 510	
21.4.4	Software Standby Mode Application Example.....	511
21.5	Hardware Standby Mode	512
21.5.1	Transition to Hardware Standby Mode.....	512
21.5.2	Clearing Hardware Standby Mode	512
21.5.3	Hardware Standby Mode Timings	512
21.6	Module Stop Mode	513
21.7	ϕ Clock Output Disabling Function	514

21.8	Usage Notes	515
21.8.1	I/O Port Status	515
21.8.2	Current Consumption during Oscillation Stabilization Wait Period.....	515
21.8.3	DTC Module Stop	515
21.8.4	On-Chip Peripheral Module Interrupt.....	515
21.8.5	Writing to MSTPCR.....	515
 Section 22 List of Registers.....		 517
22.1	Register Addresses (Address Order).....	518
22.2	Register Bits	536
22.3	Register States in Each Operating Mode	556
 Section 23 Electrical Characteristics		 573
23.1	Absolute Maximum Ratings	573
23.2	DC Characteristics	574
23.3	AC Characteristics	576
23.3.1	Clock Timing	577
23.3.2	Control Signal Timing	578
23.3.3	Timing of On-Chip Peripheral Modules	580
23.4	A/D Conversion Characteristics	589
23.5	Flash Memory Characteristics	590
 Appendix		 593
A.	I/O Port States in Each Pin State.....	593
B.	Product Code Lineup	594
C.	Package Dimensions	594
 Index		 595

Figures

Section 1 Overview

Figure 1.1	Internal Block Diagram	2
Figure 1.2	Pin Arrangement	3

Section 2 CPU

Figure 2.1	Exception Vector Table (Normal Mode)	15
Figure 2.2	Stack Structure in Normal Mode	15
Figure 2.3	Exception Vector Table (Advanced Mode)	16
Figure 2.4	Stack Structure in Advanced Mode	17
Figure 2.5	Memory Map	18
Figure 2.6	CPU Registers.....	19
Figure 2.7	Usage of General Registers.....	20
Figure 2.8	Stack	21
Figure 2.9	General Register Data Formats (1)	24
Figure 2.9	General Register Data Formats (2)	25
Figure 2.10	Memory Data Formats.....	26
Figure 2.11	Instruction Formats (Examples).....	39
Figure 2.12	Branch Address Specification in Memory Indirect Mode	43
Figure 2.13	State Transitions	47

Section 3 MCU Operating Modes

Figure 3.1	Address Map.....	53
------------	------------------	----

Section 4 Exception Handling

Figure 4.1	Reset Sequence (Advanced Mode with On-Chip ROM Enabled)	58
Figure 4.2	Reset Sequence (Advanced Mode with On-chip ROM Disabled: Not Available in this LSI).....	59
Figure 4.3	Stack Status after Exception Handling.....	63
Figure 4.4	Operation when SP Value Is Odd	64

Section 5 Interrupt Controller

Figure 5.1	Block Diagram of Interrupt Controller	66
Figure 5.2	Block Diagram of Interrupts IRQ5 to IRQ0	73
Figure 5.3	Flowchart of Procedure Up to Interrupt Acceptance in Interrupt Control Mode 0	79
Figure 5.4	Flowchart of Procedure Up to Interrupt Acceptance in Control Mode 2.....	81
Figure 5.5	Interrupt Exception Handling	82
Figure 5.6	Conflict between Interrupt Generation and Disabling	85

Section 6 PC Break Controller (PBC)

Figure 6.1	Block Diagram of PC Break Controller.....	88
Figure 6.2	Operation in Power-Down Mode Transitions.....	92

Section 7 Bus Controller

Figure 7.1	On-Chip Memory Access Cycle.....	95
Figure 7.2	On-Chip Support Module Access Cycle.....	96
Figure 7.3	On-Chip HCAN Module Access Cycle (with Wait States).....	97
Figure 7.4	On-Chip SSU Module Access Cycle.....	98

Section 8 Data Transfer Controller (DTC)

Figure 8.1	Block Diagram of DTC.....	102
Figure 8.2	Block Diagram of DTC Activation Source Control.....	108
Figure 8.3	Location of DTC Register Information in Address Space.....	109
Figure 8.4	Flowchart of DTC Operation.....	112
Figure 8.5	Memory Mapping in Normal Mode.....	113
Figure 8.6	Memory Mapping in Repeat Mode.....	114
Figure 8.7	Memory Mapping in Block Transfer Mode.....	116
Figure 8.8	Chain Transfer Operation.....	117
Figure 8.9	DTC Operation Timing (Example in Normal Mode or Repeat Mode).....	118
Figure 8.10	DTC Operation Timing (Example of Block Transfer Mode, with Block Size of 2).....	119
Figure 8.11	DTC Operation Timing (Example of Chain Transfer).....	119

Section 10 16-Bit Timer Pulse Unit (TPU)

Figure 10.1	Block Diagram of TPU.....	170
Figure 10.2	Example of Counter Operation Setting Procedure.....	205
Figure 10.3	Free-Running Counter Operation.....	206
Figure 10.4	Periodic Counter Operation.....	207
Figure 10.5	Example of Setting Procedure for Waveform Output by Compare Match.....	207
Figure 10.6	Example of 0 Output/1 Output Operation.....	208
Figure 10.7	Example of Toggle Output Operation.....	208
Figure 10.8	Example of Input Capture Operation Setting Procedure.....	209
Figure 10.9	Example of Input Capture Operation.....	210
Figure 10.10	Example of Synchronous Operation Setting Procedure.....	211
Figure 10.11	Example of Synchronous Operation.....	212
Figure 10.12	Compare Match Buffer Operation.....	213
Figure 10.13	Input Capture Buffer Operation.....	213
Figure 10.14	Example of Buffer Operation Setting Procedure.....	214
Figure 10.15	Example of Buffer Operation (1).....	215
Figure 10.16	Example of Buffer Operation (2).....	216

Figure 10.17	Cascaded Operation Setting Procedure.....	217
Figure 10.18	Example of Cascaded Operation (1).....	218
Figure 10.19	Example of Cascaded Operation (2).....	218
Figure 10.20	Example of PWM Mode Setting Procedure.....	221
Figure 10.21	Example of PWM Mode Operation (1).....	221
Figure 10.22	Example of PWM Mode Operation (2).....	222
Figure 10.23	Example of PWM Mode Operation (3).....	223
Figure 10.24	Example of Phase Counting Mode Setting Procedure.....	224
Figure 10.25	Example of Phase Counting Mode 1 Operation.....	225
Figure 10.26	Example of Phase Counting Mode 2 Operation.....	226
Figure 10.27	Example of Phase Counting Mode 3 Operation.....	227
Figure 10.28	Example of Phase Counting Mode 4 Operation.....	228
Figure 10.29	Phase Counting Mode Application Example.....	230
Figure 10.30	Count Timing in Internal Clock Operation.....	234
Figure 10.31	Count Timing in External Clock Operation.....	234
Figure 10.32	Output Compare Output Timing.....	235
Figure 10.33	Input Capture Input Signal Timing.....	235
Figure 10.34	Counter Clear Timing (Compare Match).....	236
Figure 10.35	Counter Clear Timing (Input Capture).....	236
Figure 10.36	Buffer Operation Timing (Compare Match).....	237
Figure 10.37	Buffer Operation Timing (Input Capture).....	237
Figure 10.38	TGI Interrupt Timing (Compare Match).....	238
Figure 10.39	TGI Interrupt Timing (Input Capture).....	238
Figure 10.40	TCIV Interrupt Setting Timing.....	239
Figure 10.41	TCIU Interrupt Setting Timing.....	239
Figure 10.42	Timing for Status Flag Clearing by CPU.....	240
Figure 10.43	Timing for Status Flag Clearing by DTC Activation.....	240
Figure 10.44	Phase Difference, Overlap, and Pulse Width in Phase Counting Mode.....	241
Figure 10.45	Conflict between TCNT Write and Clear Operations.....	242
Figure 10.46	Conflict between TCNT Write and Increment Operations.....	243
Figure 10.47	Conflict between TGR Write and Compare Match.....	244
Figure 10.48	Conflict between Buffer Register Write and Compare Match.....	245
Figure 10.49	Conflict between TGR Read and Input Capture.....	246
Figure 10.50	Conflict between TGR Write and Input Capture.....	247
Figure 10.51	Conflict between Buffer Register Write and Input Capture.....	248
Figure 10.52	Conflict between Overflow and Counter Clearing.....	249
Figure 10.53	Conflict between TCNT Write and Overflow.....	250

Section 11 8-Bit Timers

Figure 11.1	Block Diagram of 8-Bit Timer Module.....	252
Figure 11.2	Example of Pulse Output.....	262

Figure 11.3	Count Timing for Internal Clock Input	263
Figure 11.4	Count Timing for External Clock Input.....	263
Figure 11.5	Timing of CMF Setting.....	264
Figure 11.6	Timing of Timer Output	264
Figure 11.7	Timing of Compare-Match Clear	265
Figure 11.8	Timing of Clearing by External Reset Input.....	265
Figure 11.9	Timing of OVF Setting	266
Figure 11.10	Conflict between TCNT Write and Clear	269
Figure 11.11	Conflict between TCNT Write and Increment.....	270
Figure 11.12	Conflict between TCOR Write and Compare-Match.....	271

Section 12 Programmable Pulse Generator (PPG)

Figure 12.1	Block Diagram of PPG	276
Figure 12.2	PPG Output Operation	284
Figure 12.3	Timing of Transfer and Output of NDR Contents (Example)	285
Figure 12.4	Setup Procedure for Normal Pulse Output (Example).....	286
Figure 12.5	Normal Pulse Output Example (Five-Phase Pulse Output)	287
Figure 12.6	Non-Overlapping Pulse Output	288
Figure 12.7	Non-Overlapping Operation and NDR Write Timing	289
Figure 12.8	Setup Procedure for Non-Overlapping Pulse Output (Example).....	290
Figure 12.9	Non-Overlapping Pulse Output Example (Four-Phase Complementary)	291
Figure 12.10	Inverted Pulse Output (Example)	293
Figure 12.11	Pulse Output Triggered by Input Capture (Example)	294

Section 13 Watchdog Timer

Figure 13.1	Block Diagram of WDT	296
Figure 13.2	Example of WDT0 Watchdog Timer Operation.....	300
Figure 13.3	Writing to TCNT, TCSR, and RSTCSR (Example for WDT0).....	302
Figure 13.4	Conflict between TCNT Write and Increment.....	302

Section 14 Serial Communication Interface (SCI)

Figure 14.1	Block Diagram of SCI	306
Figure 14.2	Data Format in Asynchronous Communication (Example with 8-Bit Data, Parity, Two Stop Bits)	330
Figure 14.3	Receive Data Sampling Timing in Asynchronous Mode.....	332
Figure 14.4	Relationship between Output Clock and Transfer Data Phase (Asynchronous Mode)	333
Figure 14.5	Sample SCI Initialization Flowchart.....	334
Figure 14.6	Example of Operation in Transmission in Asynchronous Mode (Example with 8-Bit Data, Parity, One Stop Bit)	335
Figure 14.7	Sample Serial Transmission Flowchart	336

Figure 14.8	Example of SCI Operation in Reception (Example with 8-Bit Data, Parity, One Stop Bit).....	337
Figure 14.9	Sample Serial Reception Data Flowchart (1).....	339
Figure 14.9	Sample Serial Reception Data Flowchart (2).....	340
Figure 14.10	Example of Communication Using Multiprocessor Format (Transmission of Data H'AA to Receiving Station A).....	342
Figure 14.11	Sample Multiprocessor Serial Transmission Flowchart	343
Figure 14.12	Example of SCI Operation in Reception (Example with 8-Bit Data, Multiprocessor Bit, One Stop Bit)	344
Figure 14.13	Sample Multiprocessor Serial Reception Flowchart (1)	345
Figure 14.13	Sample Multiprocessor Serial Reception Flowchart (2)	346
Figure 14.14	Data Format in Synchronous Communication (For LSB-First).....	347
Figure 14.15	Sample SCI Initialization Flowchart.....	348
Figure 14.16	Sample SCI Transmission Operation in Clocked Synchronous Mode	350
Figure 14.17	Sample Serial Transmission Flowchart	351
Figure 14.18	Example of SCI Operation in Reception	352
Figure 14.19	Sample Serial Reception Flowchart.....	353
Figure 14.20	Sample Flowchart of Simultaneous Serial Transmit and Receive Operations.....	355
Figure 14.21	Schematic Diagram of Smart Card Interface Pin Connections	356
Figure 14.22	Normal Smart Card Interface Data Format.....	357
Figure 14.23	Direct Convention ($SDIR = SIN\bar{V} = O/\bar{E} = 0$).....	358
Figure 14.24	Inverse Convention ($SDIR = SIN\bar{V} = O/\bar{E} = 1$).....	358
Figure 14.25	Receive Data Sampling Timing in Smart Card Mode (Using Clock of 372 Times the Transfer Rate).....	360
Figure 14.26	Retransfer Operation in SCI Transmit Mode.....	362
Figure 14.27	TEND Flag Generation Timing in Transmission Operation.....	362
Figure 14.28	Example of Transmission Processing Flow	363
Figure 14.29	Retransfer Operation in SCI Receive Mode	364
Figure 14.30	Example of Reception Processing Flow	365
Figure 14.31	Timing for Fixing Clock Output Level.....	366
Figure 14.32	Clock Halt and Restart Procedure.....	367

Section 15 Controller Area Network (HCAN)

Figure 15.1	HCAN Block Diagram.....	372
Figure 15.2	Message Control Register Configuration.....	396
Figure 15.3	Standard Format	396
Figure 15.4	Extended Format.....	396
Figure 15.5	Message Data Configuration	398
Figure 15.6	Hardware Reset Flowchart.....	401
Figure 15.7	Software Reset Flowchart.....	402
Figure 15.8	Detailed Description of One Bit	403

Figure 15.9	Transmission Flowchart.....	406
Figure 15.10	Transmit Message Cancellation Flowchart.....	408
Figure 15.11	Reception Flowchart.....	409
Figure 15.12	Unread Message Overwrite Flowchart	412
Figure 15.13	HCAN Sleep Mode Flowchart.....	413
Figure 15.14	HCAN Halt Mode Flowchart.....	415
Figure 15.15	DTC Transfer Flowchart.....	417
Figure 15.16	High-Speed Interface Using PCA82C250	418

Section 16 Synchronous Serial Communication Unit (SSU)

Figure 16.1	Block Diagram of SSU	424
Figure 16.2	Relationship of Clock Phase, Polarity, and Data	435
Figure 16.3	Relationship between Data I/O Pins and the Shift Register.....	436
Figure 16.4	Example of SSU Initialization	437
Figure 16.5	Example of Transmission Operation	439
Figure 16.6	Example of Data Transmission Flowchart.....	440
Figure 16.7	Example of Reception Operation.....	442
Figure 16.8	Example of Data Reception Flowchart	443
Figure 16.9	Example of Simultaneous Transmission/Reception Flowchart	445
Figure 16.10	Conflict Error Detection Timing (Before Transfer Start)	446
Figure 16.11	Conflict Error Detection Timing (After Transfer End).....	447

Section 17 A/D Converter

Figure 17.1	Block Diagram of A/D Converter.....	450
Figure 17.2	A/D Conversion Timing	457
Figure 17.3	External Trigger Input Timing.....	459
Figure 17.4	A/D Conversion Accuracy Definitions	461
Figure 17.5	A/D Conversion Accuracy Definitions	461
Figure 17.6	Example of Analog Input Circuit.....	462
Figure 17.7	Example of Analog Input Protection Circuit	464
Figure 17.8	Analog Input Pin Equivalent Circuit.....	464

Section 19 ROM

Figure 19.1	Block Diagram of Flash Memory	468
Figure 19.2	Flash Memory State Transitions	469
Figure 19.3	Boot Mode	470
Figure 19.4	User Program Mode.....	471
Figure 19.5	Flash Memory Block Configuration	472
Figure 19.6	Programming/Erasing Flowchart Example in User Program Mode	481
Figure 19.7	Flowchart for Flash Memory Emulation in RAM	482
Figure 19.8	Example of RAM Overlap Operation	483

Figure 19.9	Program/Program-Verify Flowchart.....	485
Figure 19.10	Erase/Erase-Verify Flowchart.....	487
Section 20 Clock Pulse Generator		
Figure 20.1	Block Diagram of Clock Pulse Generator	491
Figure 20.2	Connection of Crystal Resonator (Example)	494
Figure 20.3	Crystal Resonator Equivalent Circuit	494
Figure 20.4	External Clock Input (Examples)	495
Figure 20.5	External Clock Input Timing	496
Figure 20.6	Note on Board Design of Oscillator Circuit	498
Figure 20.7	External Circuitry Recommended for PLL Circuit.....	499
Section 21 Power-Down Modes		
Figure 21.1	Mode Transition Diagram.....	502
Figure 21.2	Medium-Speed Mode Transition and Clearance Timing.....	508
Figure 21.3	Software Standby Mode Application Example.....	511
Figure 21.4	Timing of Transition to Hardware Standby Mode.....	512
Figure 21.5	Timing of Recovery from Hardware Standby Mode	513
Section 23 Electrical Characteristics		
Figure 23.1	Output Load Circuit.....	576
Figure 23.2	System Clock Timing	577
Figure 23.3	Oscillation Settling Timing.....	578
Figure 23.4	Reset Input Timing	579
Figure 23.5	Interrupt Input Timing	579
Figure 23.6	I/O Port Input/Output Timing	583
Figure 23.7	Realtime Input Port Data Input Timing	583
Figure 23.8	TPU Input/Output Timing	583
Figure 23.9	TPU Clock Input Timing	584
Figure 23.10	SCK Clock Input Timing.....	584
Figure 23.11	SCI Input/Output Timing (Clock Synchronous Mode).....	584
Figure 23.12	A/D Converter External Trigger Input Timing	584
Figure 23.13	HCAN Input/Output Timing.....	585
Figure 23.14	PPG Output Timing	585
Figure 23.15	8-Bit Timer Output Timing.....	585
Figure 23.16	8-Bit Timer Clock Input Timing.....	585
Figure 23.17	8-Bit Timer Reset Input Timing	586
Figure 23.18	SSU Timing (Master, CPHS = 1)	586
Figure 23.19	SSU Timing (Master, CPHS = 0)	587
Figure 23.20	SSU Timing (Slave, CPHS = 1).....	587
Figure 23.21	SSU Timing (Slave, CPHS = 0).....	588

Appendix

Figure C.1 FP-100M Package Dimensions..... 594

Tables

Section 2 CPU

Table 2.1	Instruction Classification	27
Table 2.2	Operation Notation.....	28
Table 2.3	Data Transfer Instructions.....	29
Table 2.4	Arithmetic Operations Instructions (1)	30
Table 2.4	Arithmetic Operations Instructions (2)	31
Table 2.5	Logic Operations Instructions	32
Table 2.6	Shift Instructions	33
Table 2.7	Bit Manipulation Instructions (1).....	34
Table 2.7	Bit Manipulation Instructions (2).....	35
Table 2.8	Branch Instructions	36
Table 2.9	System Control Instructions.....	37
Table 2.10	Block Data Transfer Instructions	38
Table 2.11	Addressing Modes.....	40
Table 2.12	Absolute Address Access Ranges	41

Section 3 MCU Operating Modes

Table 3.1	MCU Operating Mode Selection	49
-----------	------------------------------------	----

Section 4 Exception Handling

Table 4.1	Exception Types and Priority	55
Table 4.2	Exception Handling Vector Table.....	56
Table 4.3	Statuses of CCR and EXR after Trace Exception Handling	60
Table 4.4	Statuses of CCR and EXR after Trap Instruction Exception Handling.....	62

Section 5 Interrupt Controller

Table 5.1	Pin Configuration.....	67
Table 5.2	Interrupt Sources, Vector Addresses, and Interrupt Priorities.....	75
Table 5.3	Interrupt Control Modes.....	78
Table 5.4	Interrupt Response Times	83
Table 5.5	Number of States in Interrupt Handling Routine Execution Status.....	84

Section 8 Data Transfer Controller (DTC)

Table 8.1	Interrupt Sources, DTC Vector Addresses, and Corresponding DTCEs.....	110
Table 8.2	Register Information in Normal Mode.....	113
Table 8.3	Register Information in Repeat Mode.....	114
Table 8.4	Register Information in Block Transfer Mode	115
Table 8.5	DTC Execution Status.....	120

Table 8.6	Number of States Required for Each Execution Status.....	120
-----------	--	-----

Section 9 I/O Ports

Table 9.1	Port Functions	128
Table 9.2	P17 Pin Function.....	133
Table 9.3	P16 Pin Function.....	133
Table 9.4	P15 Pin Function.....	134
Table 9.5	P14 Pin Function.....	134
Table 9.6	P13 Pin Function.....	134
Table 9.7	P12 Pin Function.....	135
Table 9.8	P11 Pin Function.....	135
Table 9.9	P10 Pin Function.....	135
Table 9.10	P37 Pin Function.....	138
Table 9.11	P36 Pin Function.....	138
Table 9.12	P35 Pin Function.....	138
Table 9.13	P34 Pin Function.....	139
Table 9.14	P33 Pin Function.....	139
Table 9.15	P32 Pin Function.....	139
Table 9.16	P31 Pin Function.....	139
Table 9.17	P30 Pin Function.....	139
Table 9.18	P77 Pin Function.....	142
Table 9.19	P76 Pin Function.....	142
Table 9.20	P75 Pin Function.....	142
Table 9.21	P74 Pin Function.....	143
Table 9.22	P73 Pin Function.....	143
Table 9.23	P72 Pin Function.....	143
Table 9.24	P71 Pin Function.....	143
Table 9.25	P70 Pin Function.....	143
Table 9.26	PA3 Pin Function.....	148
Table 9.27	PA2 Pin Function.....	148
Table 9.28	PA1 Pin Function.....	148
Table 9.29	PA0 Pin Function.....	148
Table 9.30	PB7 Pin Function	152
Table 9.31	PB6 Pin Function	152
Table 9.32	PB5 Pin Function	152
Table 9.33	PB4 Pin Function	153
Table 9.34	PB3 Pin Function	153
Table 9.35	PB2 Pin Function	153
Table 9.36	PB1 Pin Function	153
Table 9.37	PB0 Pin Function	154
Table 9.38	PC7 Pin Function	157

Table 9.39	PC6 Pin Function	157
Table 9.40	PC5 Pin Function	157
Table 9.41	PC4 Pin Function	158
Table 9.42	PC3 Pin Function	158
Table 9.43	PC2 Pin Function	158
Table 9.44	PC1 Pin Function	159
Table 9.45	PC0 Pin Function	159
Table 9.46	PF7 Pin Function.....	165
Table 9.47	PF6 Pin Function.....	165
Table 9.48	PF5 Pin Function.....	165
Table 9.49	PF4 Pin Function.....	165
Table 9.50	PF3 Pin Function.....	165
Table 9.51	PF2 Pin Function.....	166
Table 9.52	PF1 Pin Function.....	166
Table 9.53	PF0 Pin Function.....	166

Section 10 16-Bit Timer Pulse Unit (TPU)

Table 10.1	TPU Functions	168
Table 10.2	TPU Pins	171
Table 10.3	CCLR2 to CCLR0 (Channels 0 and 3).....	175
Table 10.4	CCLR2 to CCLR0 (Channels 1, 2, 4, and 5).....	175
Table 10.5	TPSC2 to TPSC0 (Channel 0).....	176
Table 10.6	TPSC2 to TPSC0 (Channel 1).....	176
Table 10.7	TPSC2 to TPSC0 (Channel 2).....	177
Table 10.8	TPSC2 to TPSC0 (Channel 3).....	177
Table 10.9	TPSC2 to TPSC0 (Channel 4).....	178
Table 10.10	TPSC2 to TPSC0 (Channel 5).....	178
Table 10.11	MD3 to MD0.....	180
Table 10.12	TIORH_0 (Channel 0)	182
Table 10.13	TIORL_0 (Channel 0).....	183
Table 10.14	TIOR_1 (Channel 1)	184
Table 10.15	TIOR_2 (Channel 2)	185
Table 10.16	TIORH_3 (Channel 3)	186
Table 10.17	TIORL_3 (Channel 3).....	187
Table 10.18	TIOR_4 (Channel 4)	188
Table 10.19	TIOR_5 (Channel 5)	189
Table 10.20	TIORH_0 (Channel 0)	190
Table 10.21	TIORL_0 (Channel 0).....	191
Table 10.22	TIOR_1 (Channel 1)	192
Table 10.23	TIOR_2 (Channel 2)	193
Table 10.24	TIORH_3 (Channel 3)	194

Table 10.25	TIORL_3 (Channel 3).....	195
Table 10.26	TIOR_4 (Channel 4)	196
Table 10.27	TIOR_5 (Channel 5)	197
Table 10.28	Register Combinations in Buffer Operation.....	213
Table 10.29	Cascaded Combinations	217
Table 10.30	PWM Output Registers and Output Pins.....	220
Table 10.31	Phase Counting Mode Clock Input Pins	224
Table 10.32	Up/Down-Count Conditions in Phase Counting Mode 1	225
Table 10.33	Up/Down-Count Conditions in Phase Counting Mode 2	226
Table 10.34	Up/Down-Count Conditions in Phase Counting Mode 3	227
Table 10.35	Up/Down-Count Conditions in Phase Counting Mode 4	228
Table 10.36	TPU Interrupts	232

Section 11 8-Bit Timers

Table 11.1	Pin Configuration.....	253
Table 11.2	8-Bit Timer Interrupt Sources	268
Table 11.3	Timer Output Priorities	271
Table 11.4	Switching of Internal Clock and TCNT Operation	272

Section 12 Programmable Pulse Generator (PPG)

Table 12.1	Pin Configuration.....	277
------------	------------------------	-----

Section 13 Watchdog Timer

Table 13.1	WDT Interrupt Source	301
------------	----------------------------	-----

Section 14 Serial Communication Interface (SCI)

Table 14.1	Pin Configuration.....	307
Table 14.2	The Relationships between The N Setting in BRR and Bit Rate B.....	323
Table 14.3	BRR Settings for Various Bit Rates (Asynchronous Mode) (1)	324
Table 14.3	BRR Settings for Various Bit Rates (Asynchronous Mode) (2)	325
Table 14.3	BRR Settings for Various Bit Rates (Asynchronous Mode) (3)	326
Table 14.4	Maximum Bit Rate for Each Frequency (Asynchronous Mode).....	326
Table 14.5	Maximum Bit Rate with External Clock Input (Asynchronous Mode).....	327
Table 14.6	BRR Settings for Various Bit Rates (Clocked Synchronous Mode)	328
Table 14.7	Maximum Bit Rate with External Clock Input (Clocked Synchronous Mode).....	328
Table 14.8	Examples of Bit Rate for Various BRR Settings (Smart Card Interface Mode) (When n = 0 and S = 372)	329
Table 14.9	Maximum Bit Rate at Various Frequencies (Smart Card Interface Mode) (When S = 372).....	329
Table 14.10	Serial Transfer Formats (Asynchronous Mode).....	331
Table 14.11	SSR Status Flags and Receive Data Handling	338

Table 14.12	SCI Interrupt Sources.....	368
Table 14.13	SCI Interrupt Sources.....	369
Section 15 Controller Area Network (HCAN)		
Table 15.1	HCAN Pins	373
Table 15.2	Limits for the Settable Value	403
Table 15.3	Setting Range for TSEG1 and TSEG2 in BCR.....	404
Table 15.4	HCAN Interrupt Sources.....	416
Table 15.5	Interval Limitation between TXPR and TXPR or between TXPR and TXCR	421
Section 16 Synchronous Serial Communication Unit (SSU)		
Table 16.1	Pin Configuration.....	425
Table 16.2	Interrupt Sources	448
Section 17 A/D Converter		
Table 17.1	Pin Configuration.....	451
Table 17.2	Analog Input Channels and Corresponding ADDR Registers	452
Table 17.3	A/D Conversion Time (Single Mode).....	458
Table 17.4	A/D Conversion Time (Scan Mode)	458
Table 17.5	A/D Converter Interrupt Source.....	459
Table 17.6	Analog Pin Specifications	464
Section 19 ROM		
Table 19.1	Differences between Boot Mode and User Program Mode.....	469
Table 19.2	Pin Configuration.....	473
Table 19.3	Setting On-Board Programming Modes.....	477
Table 19.4	Boot Mode Operation.....	479
Table 19.5	System Clock Frequencies for which Automatic Adjustment of LSI Bit Rate is Possible	479
Table 19.6	Flash Memory Operating States.....	489
Table 19.7	Registers Present in F-ZTAT Version but Absent in Masked ROM Version	490
Section 20 Clock Pulse Generator		
Table 20.1	Damping Resistance Value	494
Table 20.2	Crystal Resonator Characteristics	495
Table 20.3	External Clock Input Conditions.....	496
Section 21 Power-Down Modes		
Table 21.1	Low Power Consumption Mode Transition Conditions.....	502
Table 21.2	LSI Internal States in Each Mode	503
Table 21.3	Oscillation Stabilization Time Settings.....	510

Table 21.4	ϕ Pin State in Each Processing State	514
------------	---	-----

Section 23 Electrical Characteristics

Table 23.1	Absolute Maximum Ratings	573
Table 23.2	DC Characteristics	574
Table 23.3	Permissible Output Currents	576
Table 23.4	Clock Timing	577
Table 23.5	Control Signal Timing.....	578
Table 23.6	Timing of On-Chip Peripheral Modules	580
Table 23.7	Timing of SSU	582
Table 23.8	A/D Conversion Characteristics.....	589
Table 23.9	Flash Memory Characteristics.....	590

Section 1 Overview

1.1 Overview

- High-speed H8S/2600 central processing unit with an internal 16-bit architecture
 - Upward-compatible with H8/300 and H8/300H CPUs on an object level
 - Sixteen 16-bit general registers
 - 69 basic instructions
- Various peripheral functions
 - PC break controller
 - Data transfer controller
 - 16-bit timer-pulse unit (TPU)
 - 8-bit timer (TMR)
 - Programmable pulse generator (PPG)
 - Watchdog timer
 - Asynchronous or clocked synchronous serial communication interface (SCI)
 - Controller area network (HCAN)
 - Synchronous serial communication unit (SSU)
 - 10-bit A/D converter
 - Clock pulse generator
- On-chip memory

ROM	Model	ROM	RAM	Remarks
F-ZTAT Version	HD64F2628	128 kbytes	8 kbytes	
Masked ROM Version	HD6432628	128 kbytes	8 kbytes	
	HD6432627	128 kbytes	6 kbytes	

- General I/O ports
 - I/O pins: 59
 - Input-only pins: 17
- Supports various power-down states
- Compact package

Package	Package Code	Body Size	Pin Pitch
QFP-100	FP-100M	14.0 × 14.0 mm	0.5 mm

1.2 Internal Block Diagram

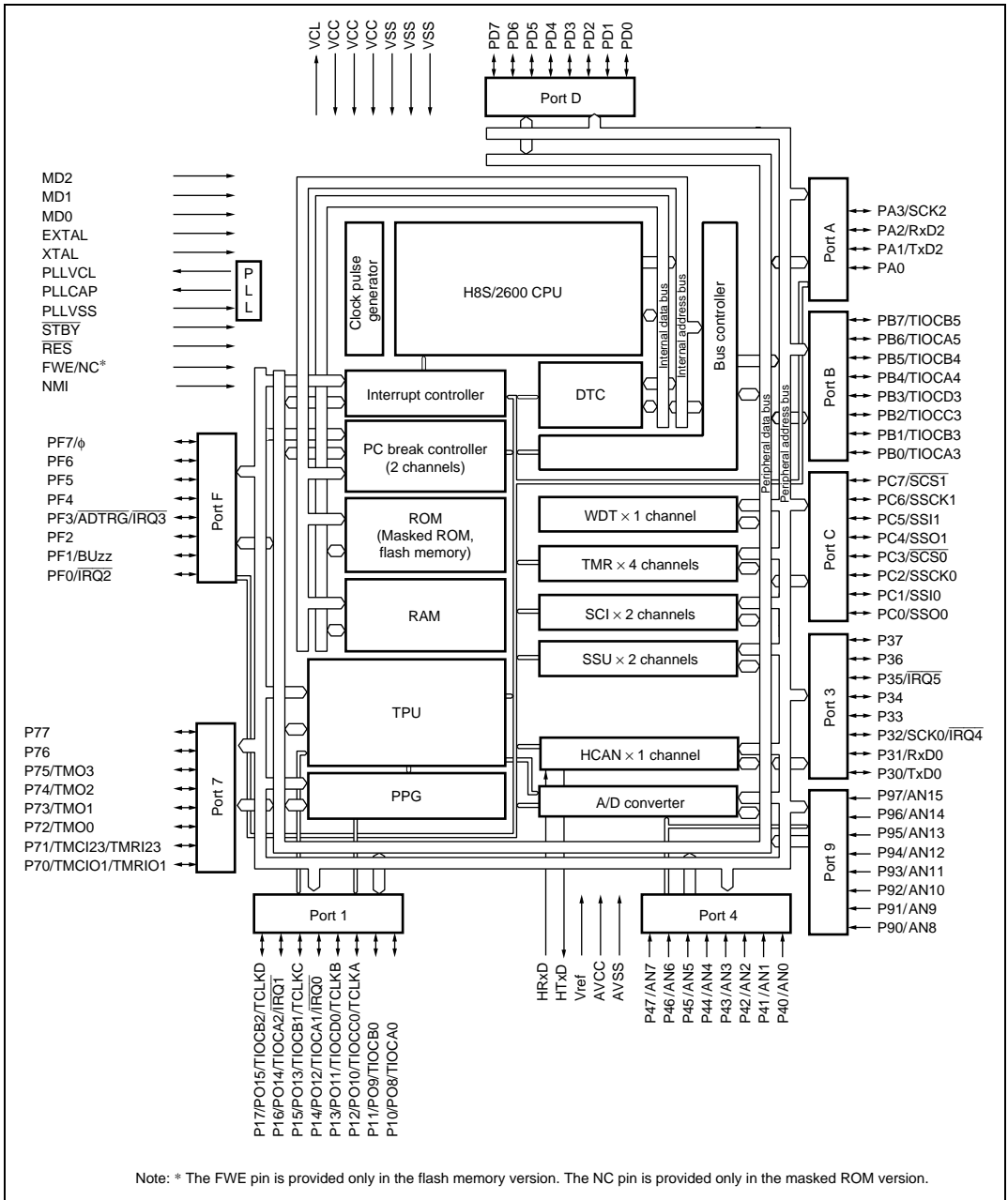

Figure 1.1 Internal Block Diagram

1.4 Pin Functions

Type	Symbol	Pin NO.	I/O	Function
Power Supply	VCC	2 32 61	Input	Power supply pins. Connect all these pins to the system power supply.
	VSS	4 34 56 64	Input	Ground pins. Connect all these pins to the system power supply (0 V).
	VCL	58	Output	External capacitance pin for internal power-down power supply. Connect this pin to VSS via a 0.1- μ F capacitor (placed close to the pins).
Clock	PLL \overline VSS	65	Input	On-chip PLL oscillator ground pin.
	PLL \overline CAP	67	Output	External capacitance pin for an on-chip PLL oscillator.
	XTAL	62	Input	For connection to a crystal resonator. For examples of crystal resonator connection and external clock input, see section 20, Clock Pulse Generator.
	EXTAL	63	Input	For connection to a crystal resonator (An external clock can be supplied from the EXTAL pin). For examples of crystal resonator connection and external clock input, see section 20, Clock Pulse Generator.
	ϕ	68	Output	Supplies the system clock to external devices.
Operating mode control	MD2	55	Input	Set the operating mode. Inputs at these pins should not be changed during operation.
	MD1	54		
	MD0	53		
System control	\overline RES	57	Input	Reset input pin. When this pin is low, the chip is reset.
	\overline STBY	59	Input	When this pin is low, a transition is made to hardware standby mode.
	FWE	66	Input	Pin for use by flash memory. This pin is only used in the flash memory version.

Type	Symbol	Pin NO.	I/O	Function
Interrupts	NMI	60	Input	Nonmaskable interrupt pin. If this pin is not used, it should be fixed high.
	$\overline{\text{IRQ5}}$	47	Input	These pins request a maskable interrupt.
	$\overline{\text{IRQ4}}$	50		
	$\overline{\text{IRQ3}}$	72		
	$\overline{\text{IRQ2}}$	75		
	$\overline{\text{IRQ1}}$	1		
	$\overline{\text{IRQ0}}$	99		
16-bit timer-pulse unit	TCLKA	97	Input	These pins input an external clock.
	TCLKB	98		
	TCLKC	100		
	TCLKD	3		
	TIOCA0	95	Input/	TGRA_0 to TGRD_0 input capture input/output compare output/PWM output pins.
	TIOCB0	96	Output	
	TIOCC0	97		
	TIOCD0	98		
	TIOCA1	99	Input/	TGRA_1 to TGRB_1 input capture input/output compare output/PWM output pins.
	TIOCB1	100	Output	
	TIOCA2	1	Input/	TGRA_2 to TGRB_2 input capture input/output compare output/PWM output pins.
	TIOCB2	3	Output	
	TIOCA3	31	Input/	TGRA_3 to TGRD_3 input capture input/output compare output/PWM output pins.
	TIOCB3	33	Output	
	TIOCC3	35		
	TIOCD3	36		
	TIOCA4	37	Input/	TGRA_4 to TGRB_4 input capture input/output compare output/PWM output pins.
	TIOCB4	38	Output	
	TIOCA5	39	Input/	TGRA_5 to TGRB_5 input capture input/output compare output/PWM output pins.
	TIOCB5	40	Output	
Program-mable pulse generator (PPG)	PO15	3	Output	Pulse output pins.
	PO14	1		
	PO13	100		
	PO12	99		
	PO11	98		
	PO10	97		
	PO9	96		
PO8	95			

Type	Symbol	Pin NO.	I/O	Function
8-bit timer (TMR)	TMO3	12	Output	Compare-match output pins.
	TMO2	11		
	TMO1	10		
	TMO0	9		
	TMCI23	8	Input	Input pins of external clocks input to the counter.
TMCI01	7			
8-bit timer (TMR)	TMRI23	8	Input	Counter reset input pins.
	TMRI01	7		
Serial communi- cation Interface (SCI)/ smart card interface	TxD2	42	Output	Data output pins.
	TxD0	52		
	RxD2	43	Input	Data input pins.
	RxD0	51		
SCK2	44	Input/ Output	Clock input/output pins.	
SCK0	50			
HCAN	HTxD	6	Output	CAN bus transmission pin.
	HRxD	5	Input	CAN bus reception pin.
Synchro- nous serial communi- cation unit (SSU)	SSO1	27	Input/ Output	Data input/output pins.
	SSO0	23		
	SSI1	28	Input/ Output	Data input/output pins.
	SSI0	24		
	SSCK1	29	Input/ Output	Clock input/output pins.
	SSCK0	25		
$\overline{\text{SCS1}}$	30	Input/ Output	Chip select input/output pins.	
$\overline{\text{SCS0}}$	26			

Type	Symbol	Pin NO.	I/O	Function
A/D converter	AN15	76	Input	Analog input pins.
	AN14	77		
	AN13	78		
	AN12	79		
	AN11	80		
	AN10	81		
	AN9	82		
	AN8	83		
	AN7	87		
	AN6	88		
	AN5	89		
	AN4	90		
	AN3	91		
	AN2	92		
	AN1	93		
AN0	94			
	$\overline{\text{ADTRG}}$	72	Input	Pin for input of an external trigger to start A/D conversion.
	AVCC	86	Input	Power supply pin for the A/D converter. When the A/D converter is not used, connect this pin to the system power supply (+5 V).
	AVSS	84	Input	The ground pin for the A/D converter. Connect this pin to the system power supply (0 V).
	Vref	85	Input	The reference voltage input pin for the A/D converter. When the A/D converter is not used, connect this pin to the system power supply (+5 V).
I/O ports	P17	3	Input/ Output	Eight input/output pins.
	P16	1		
	P15	100		
	P14	99		
	P13	98		
	P12	97		
	P11	96		
	P10	95		

Type	Symbol	Pin NO.	I/O	Function
I/O ports	P37	45	Input/ Output	Eight input/output pins.
	P36	46		
	P35	47		
	P34	48		
	P33	49		
	P32	50		
	P31	51		
	P30	52		
	P47	87	Input	Eight input pins.
	P46	88		
	P45	89		
	P44	90		
	P43	91		
	P42	92		
	P41	93		
	P40	94		
	P77	14	Input/ Output	Eight input/output pins.
	P76	13		
	P75	12		
	P74	11		
	P73	10		
P72	9			
P71	8			
P70	7			
P97	76	Input	Eight input pins.	
P96	77			
P95	78			
P94	79			
P93	80			
P92	81			
P91	82			
P90	83			
PA3	44	Input/ Output	Four input/output pins.	
PA2	43			
PA1	42			
PA0	41			

Type	Symbol	Pin NO.	I/O	Function
I/O ports	PB7	40	Input/ Output	Eight input/output pins.
	PB6	39		
	PB5	38		
	PB4	37		
	PB3	36		
	PB2	35		
	PB1	33		
	PB0	31		
	PC7	30	Input/ Output	Eight input/output pins.
	PC6	29		
	PC5	28		
	PC4	27		
	PC3	26		
	PC2	25		
	PC1	24		
	PC0	23		
	PD7	22	Input/ Output	Eight input/output pins.
	PD6	21		
	PD5	20		
	PD4	19		
	PD3	18		
PD2	17			
PD1	16			
PD0	15			
PF7	68	Input/ Output	Eight input/output pins.	
PF6	69			
PF5	70			
PF4	71			
PF3	72			
PF2	73			
PF1	74			
PF0	75			

Section 2 CPU

The H8S/2600 CPU is a high-speed central processing unit with an internal 32-bit architecture that is upward-compatible with the H8/300 and H8/300H CPUs. The H8S/2600 CPU has sixteen 16-bit general registers, can address a 16-Mbyte linear address space, and is ideal for realtime control. This section describes the H8S/2600 CPU. The usable modes and address spaces differ depending on the product. For details on each product, refer to section 3, MCU Operating Modes.

2.1 Features

- Upward-compatible with H8/300 and H8/300H CPUs
 - Can execute H8/300 and H8/300H CPUs object programs
- General-register architecture
 - Sixteen 16-bit general registers also usable as sixteen 8-bit registers or eight 32-bit registers
- Sixty-nine basic instructions
 - 8/16/32-bit arithmetic and logic instructions
 - Multiply and divide instructions
 - Powerful bit-manipulation instructions
 - Multiply-and-accumulate instruction
- Eight addressing modes
 - Register direct [Rn]
 - Register indirect [@ERn]
 - Register indirect with displacement [@(d:16,ERn) or @(d:32,ERn)]
 - Register indirect with post-increment or pre-decrement [@ERn+ or @-ERn]
 - Absolute address [@aa:8, @aa:16, @aa:24, or @aa:32]
 - Immediate [#xx:8, #xx:16, or #xx:32]
 - Program-counter relative [@(d:8,PC) or @(d:16,PC)]
 - Memory indirect [@@aa:8]
- 16-Mbyte address space
 - Program: 16 Mbytes
 - Data: 16 Mbytes
- High-speed operation
 - All frequently-used instructions execute in one or two states
 - 8/16/32-bit register-register add/subtract: 1 state
 - 8 × 8-bit register-register multiply: 3 states
 - 16 ÷ 8-bit register-register divide: 12 states

- 16×16 -bit register-register multiply: 4 states
- $32 \div 16$ -bit register-register divide: 20 states
- Two CPU operating modes
 - Normal mode*
 - Advanced mode
- Power-down state
 - Transition to power-down state by the SLEEP instruction
 - CPU clock speed selection

Note: * Normal mode is not available in this LSI.

2.1.1 Differences between H8S/2600 CPU and H8S/2000 CPU

The differences between the H8S/2600 CPU and the H8S/2000 CPU are shown below.

- Register configuration
The MAC register is supported by the H8S/2600 CPU only.
- Basic instructions
The four instructions MAC, CLRMAC, LDMAC, and STMAC are supported by the H8S/2600 CPU only.
- The number of execution states of the MULXU and MULXS instructions;

Instruction	Mnemonic	Execution States	
		H8S/2600	H8S/2000
MULXU	MULXU.B Rs, Rd	3	12
	MULXU.W Rs, ERd	4	20
MULXS	MULXS.B Rs, Rd	4	13
	MULXS.W Rs, ERd	5	21

In addition, there are differences in address space, CCR and EXR register functions, and power-down modes, etc., depending on the model.

2.1.2 Differences from H8/300 CPU

In comparison to the H8/300 CPU, the H8S/2600 CPU has the following enhancements:

- More general registers and control registers
 - Eight 16-bit extended registers, and one 8-bit and two 32-bit control registers, have been added.
- Expanded address space
 - Normal mode supports the same 64-kbyte address space as the H8/300 CPU.
 - Advanced mode supports a maximum 16-Mbyte address space.
- Enhanced addressing
 - The addressing modes have been enhanced to make effective use of the 16-Mbyte address space.
- Enhanced instructions
 - Addressing modes of bit-manipulation instructions have been enhanced.
 - Signed multiply and divide instructions have been added.
 - A multiply-and-accumulate instruction has been added.
 - Two-bit shift instructions have been added.
 - Instructions for saving and restoring multiple registers have been added.
 - A test and set instruction has been added.
- Higher speed
 - Basic instructions execute twice as fast.

2.1.3 Differences from H8/300H CPU

In comparison to the H8/300H CPU, the H8S/2600 CPU has the following enhancements:

- More control registers
 - One 8-bit and two 32-bit control registers have been added.
- Enhanced instructions
 - Addressing modes of bit-manipulation instructions have been enhanced.
 - A multiply-and-accumulate instruction has been added.
 - Two-bit shift instructions have been added.
 - Instructions for saving and restoring multiple registers have been added.
 - A test and set instruction has been added.
- Higher speed
 - Basic instructions execute twice as fast.

2.2 CPU Operating Modes

The H8S/2600 CPU has two operating modes: normal and advanced. Normal mode supports a maximum 64-kbyte address space. Advanced mode supports a maximum 16-Mbyte total address space. The mode is selected by the mode pins.

2.2.1 Normal Mode

The exception vector table and stack have the same structure as in the H8/300 CPU.

- Address Space

Linear access to a 64-kbyte maximum address space is provided.

- Extended Registers (En)

The extended registers (E7 to E0) can be used as 16-bit registers, or as the upper 16-bit segments of 32-bit registers. When En is used as a 16-bit register it can contain any value, even when the corresponding general register (Rn) is used as an address register. If the general register is referenced in the register indirect addressing mode with pre-decrement (@-Rn) or post-increment (@Rn+) and a carry or borrow occurs, however, the value in the corresponding extended register (En) will be affected.

- Instruction Set

All instructions and addressing modes can be used. Only the lower 16 bits of effective addresses (EA) are valid.

- Exception Vector Table and Memory Indirect Branch Addresses

In normal mode the top area starting at H'0000 is allocated to the exception vector table. One branch address is stored per 16 bits. The exception vector table structure in normal mode is shown in figure 2.1. For details of the exception vector table, see section 4, Exception Handling.

The memory indirect addressing mode (@@aa:8) employed in the JMP and JSR instructions uses an 8-bit absolute address included in the instruction code to specify a memory operand that contains a branch address. In normal mode the operand is a 16-bit word operand, providing a 16-bit branch address. Branch addresses can be stored in the area from H'0000 to H'00FF. Note that the first part of this range is also used for the exception vector table.

- Stack Structure

When the program counter (PC) is pushed onto the stack in a subroutine call, and the PC, condition-code register (CCR), and extended control register (EXR) are pushed onto the stack in exception handling, they are stored as shown in figure 2.2. EXR is not pushed onto the stack in interrupt control mode 0. For details, see section 4, Exception Handling.

Note: Normal mode is not available in this LSI.

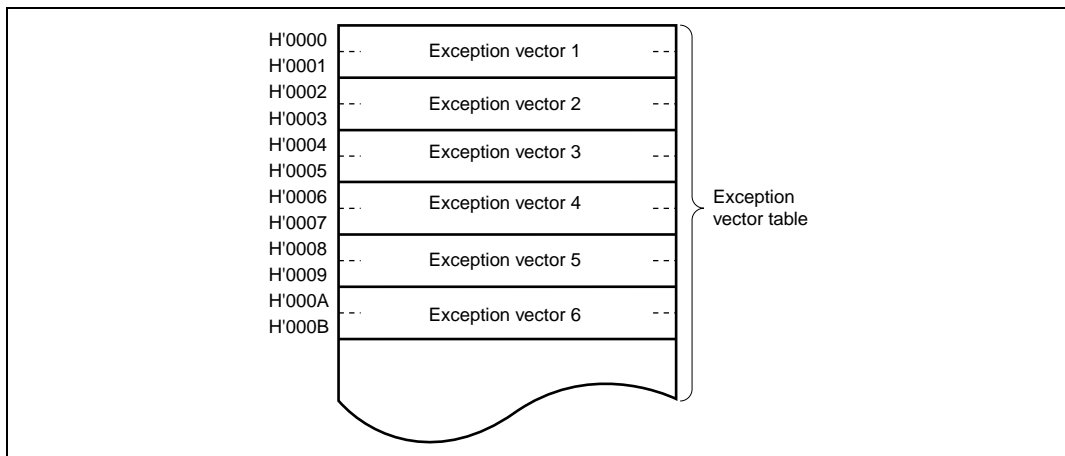

Figure 2.1 Exception Vector Table (Normal Mode)

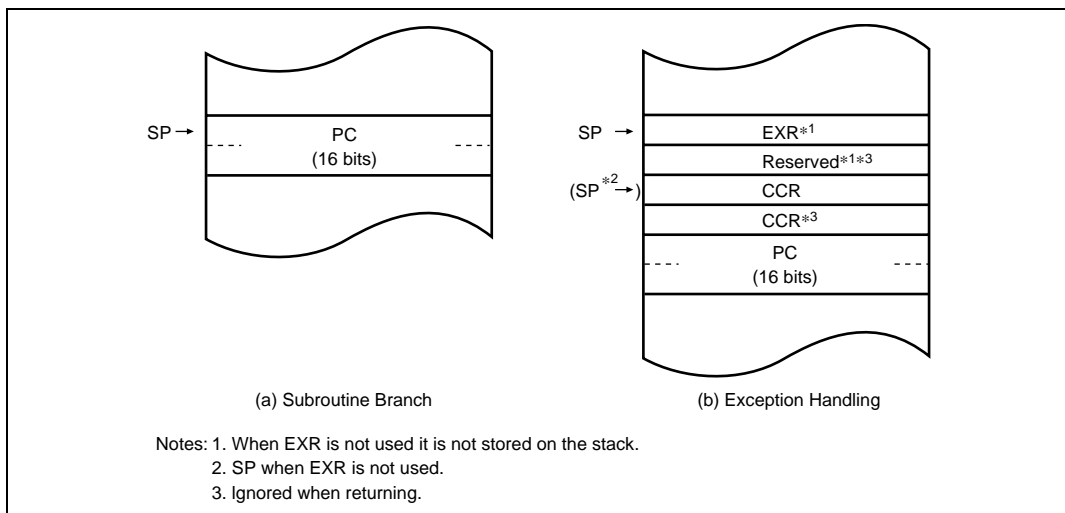

Figure 2.2 Stack Structure in Normal Mode

2.2.2 Advanced Mode

- Address Space

Linear access to a 16-Mbyte maximum address space is provided.

- Extended Registers (En)

The extended registers (E7 to E0) can be used as 16-bit registers, or as the upper 16-bit segments of 32-bit registers or address registers.

- Instruction Set

All instructions and addressing modes can be used.

- Exception Vector Table and Memory Indirect Branch Addresses

In advanced mode, the top area starting at H'00000000 is allocated to the exception vector table in units of 32 bits. In each 32 bits, the upper 8 bits are ignored and a branch address is stored in the lower 24 bits (figure 2.3). For details of the exception vector table, see section 4, Exception Handling.

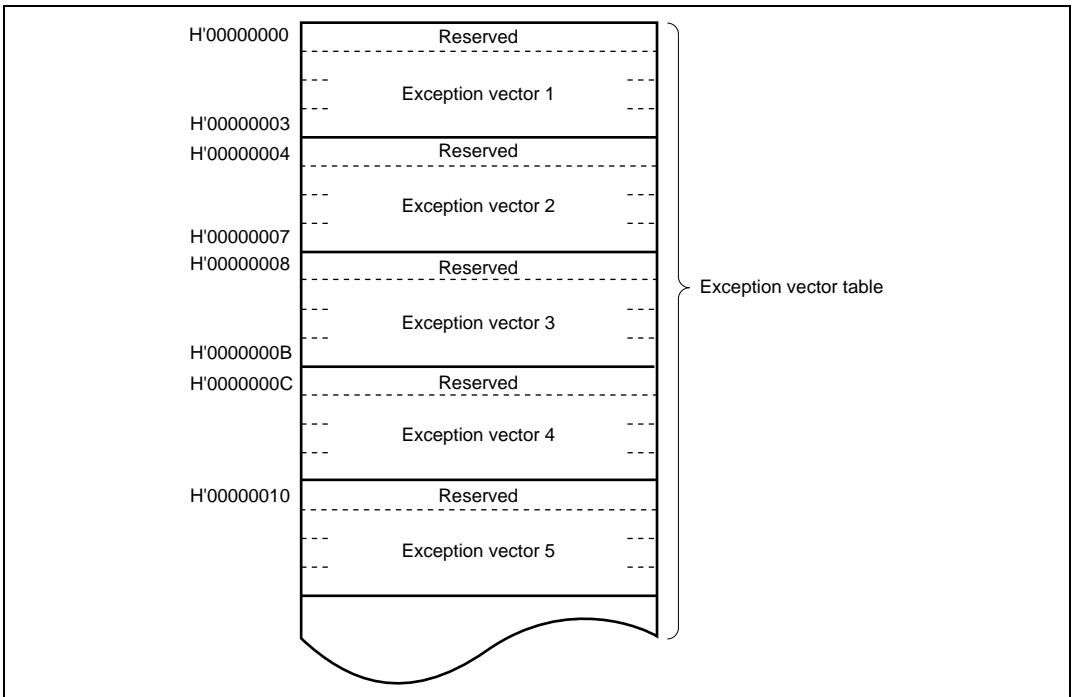

Figure 2.3 Exception Vector Table (Advanced Mode)

The memory indirect addressing mode (@@aa:8) employed in the JMP and JSR instructions uses an 8-bit absolute address included in the instruction code to specify a memory operand that contains a branch address. In advanced mode the operand is a 32-bit longword operand, providing a 32-bit branch address. The upper 8 bits of these 32 bits is a reserved area that is regarded as H'00. Branch addresses can be stored in the area from H'00000000 to H'000000FF. Note that the first part of this range is also used for the exception vector table.

- Stack Structure

In advanced mode, when the program counter (PC) is pushed onto the stack in a subroutine call, and the PC, condition-code register (CCR), and extended control register (EXR) are pushed onto the stack in exception handling, they are stored as shown in figure 2.4. When EXR is not pushed onto the stack in interrupt control mode 0. For details, see section 4, Exception Handling.

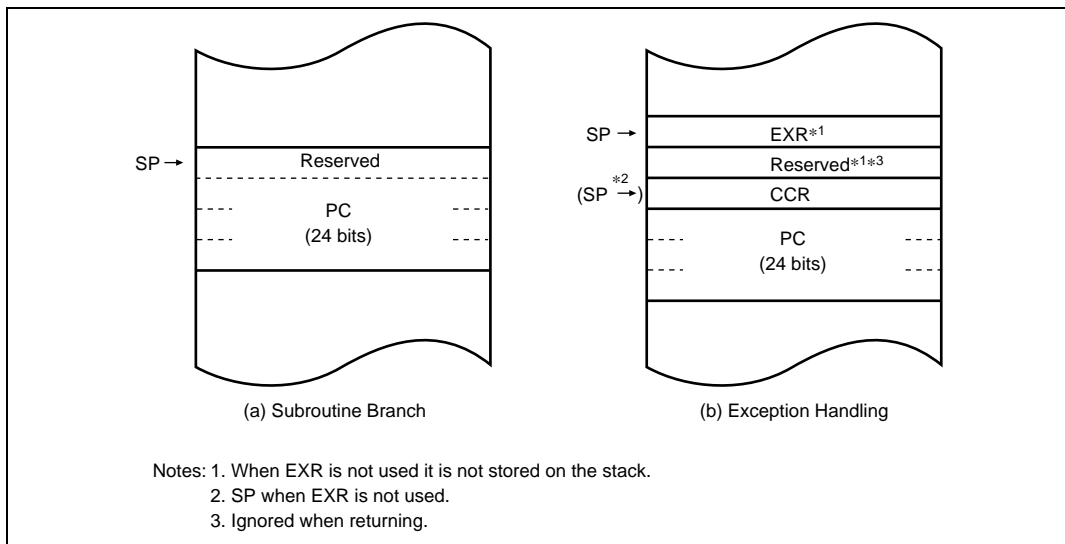

Figure 2.4 Stack Structure in Advanced Mode

2.3 Address Space

Figure 2.5 shows a memory map for the H8S/2600 CPU. The H8S/2600 CPU provides linear access to a maximum 64-kbyte address space in normal mode, and a maximum 16-Mbyte (architecturally 4-Gbyte) address space in advanced mode. The usable modes and address spaces differ depending on the product. For details on each product, refer to section 3, MCU Operating Modes.

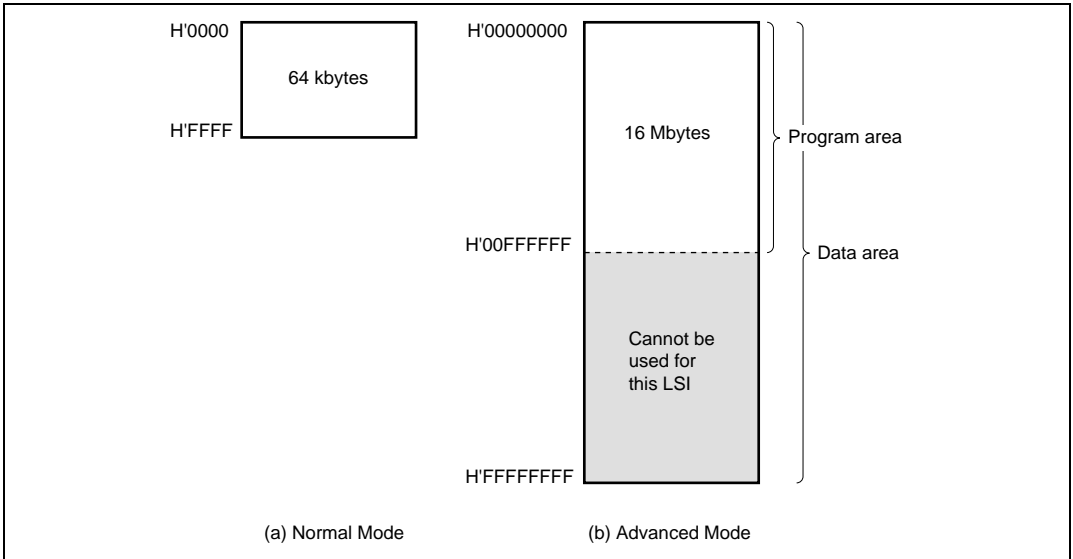

Figure 2.5 Memory Map

2.4 Registers

The H8S/2600 CPU has the internal registers shown in figure 2.6. There are two types of registers; general registers and control registers. The control registers are a 24-bit program counter (PC), an 8-bit extended control register (EXR), an 8-bit condition code register (CCR), and a 64-bit multiply-accumulate register (MAC).

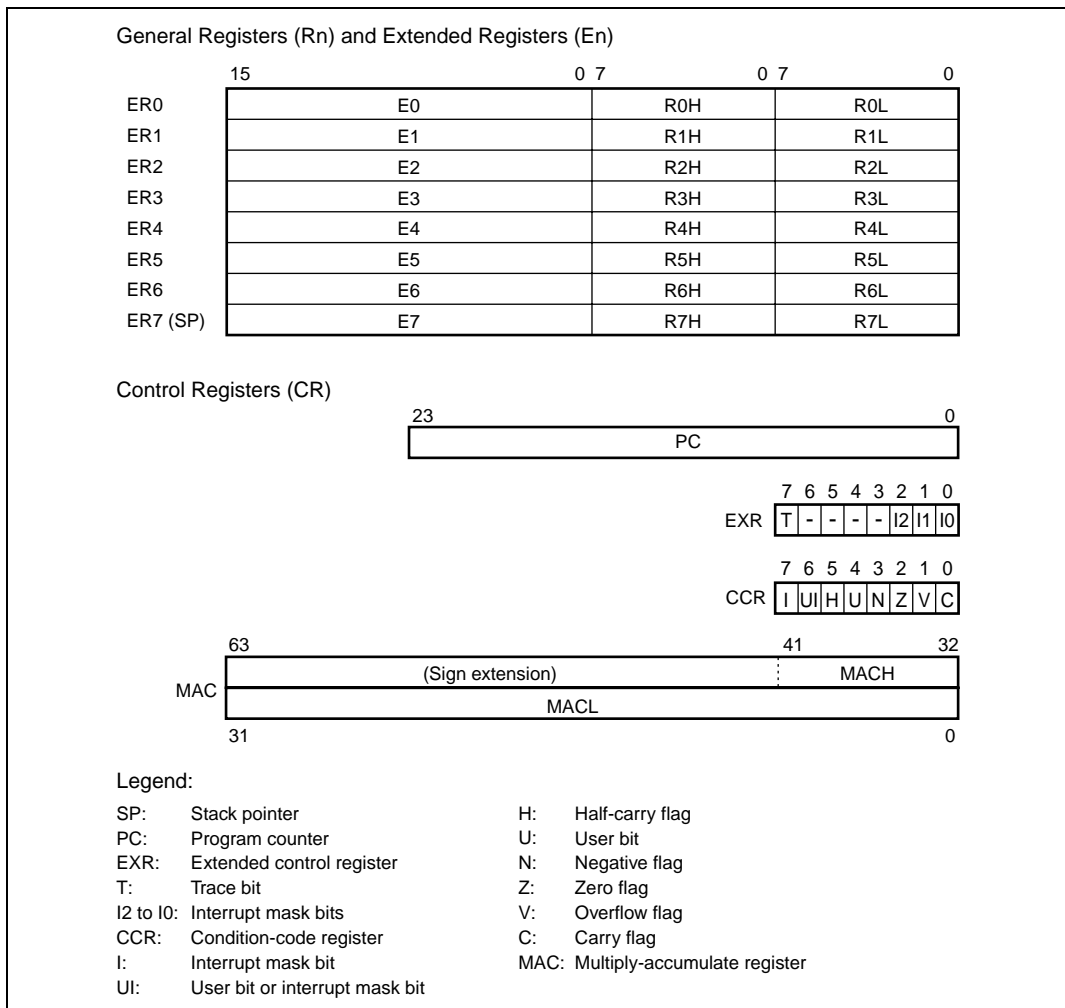

Figure 2.6 CPU Registers

2.4.1 General Registers

The H8S/2600 CPU has eight 32-bit general registers. These general registers are all functionally identical and can be used as both address registers and data registers. When a general register is used as a data register, it can be accessed as a 32-bit, 16-bit, or 8-bit register. Figure 2.7 illustrates the usage of the general registers. When the general registers are used as 32-bit registers or address registers, they are designated by the letters ER (ER7 to ER0).

The ER registers divide into 16-bit general registers designated by the letters E (E7 to E0) and R (R7 to R0). These registers are functionally equivalent, providing a maximum of sixteen 16-bit registers. The E registers (E7 to E0) are also referred to as extended registers.

The R registers divide into 8-bit general registers designated by the letters RH (R7H to R0H) and RL (R7L to R0L). These registers are functionally equivalent, providing a maximum of sixteen 8-bit registers.

The usage of each register can be selected independently.

General register ER7 has the function of stack pointer (SP) in addition to its general-register function, and is used implicitly in exception handling and subroutine calls. Figure 2.8 shows the stack.

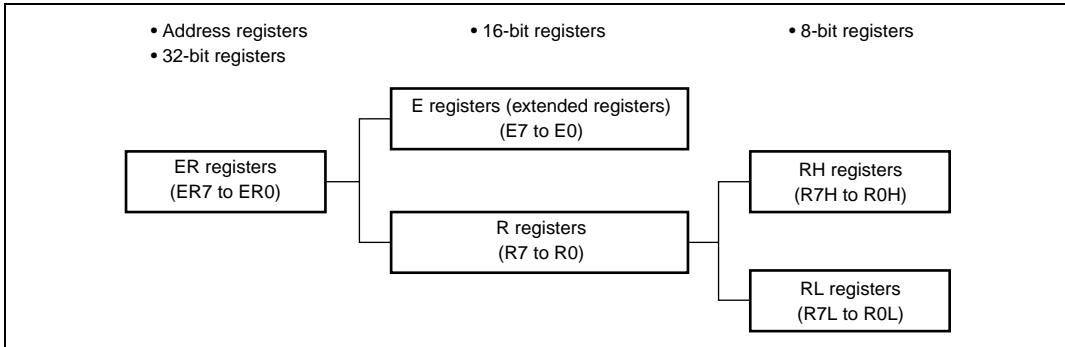

Figure 2.7 Usage of General Registers

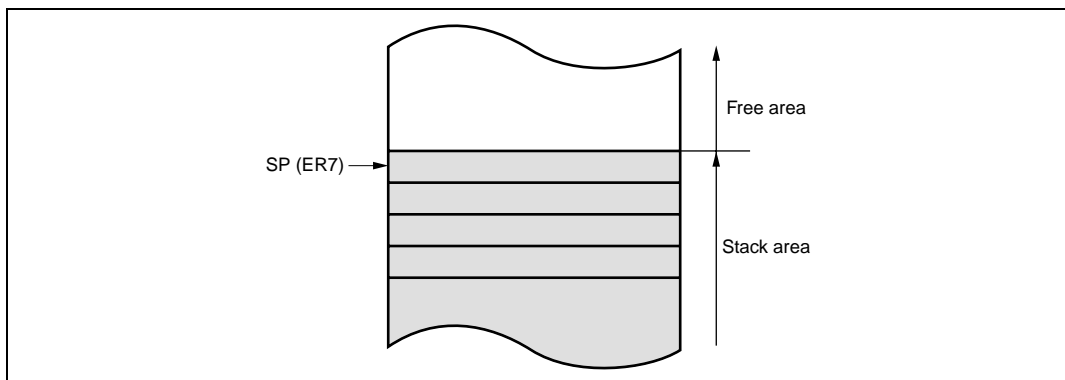

Figure 2.8 Stack

2.4.2 Program Counter (PC)

This 24-bit counter indicates the address of the next instruction the CPU will execute. The length of all CPU instructions is 2 bytes (one word), so the least significant PC bit is ignored (When an instruction is fetched, the least significant PC bit is regarded as 0).

2.4.3 Extended Control Register (EXR)

EXR is an 8-bit register that manipulates the LDC, STC, ANDC, ORC, and XORC instructions. When these instructions, except for the STC instruction, are executed, all interrupts including NMI will be masked for three states after execution is completed.

Bit	Bit Name	Initial Value	R/W	Description
7	T	0	R/W	Trace Bit When this bit is set to 1, a trace exception is generated each time an instruction is executed. When this bit is cleared to 0, instructions are executed in sequence.
6 to 3	—	All 1	—	Reserved These bits are always read as 1.
2	I2	1	R/W	These bits designate the interrupt mask level (7 to 0). For details, refer to section 5, Interrupt Controller.
1	I1	1	R/W	
0	I0	1	R/W	

2.4.4 Condition-Code Register (CCR)

This 8-bit register contains internal CPU status information, including an interrupt mask bit (I) and half-carry (H), negative (N), zero (Z), overflow (V), and carry (C) flags.

Operations can be performed on the CCR bits by the LDC, STC, ANDC, ORC, and XORC instructions. The N, Z, V, and C flags are used as branching conditions for conditional branch (Bcc) instructions.

Bit	Bit Name	Initial Value	R/W	Description
7	I	1	R/W	<p>Interrupt Mask Bit</p> <p>Masks interrupts other than NMI when set to 1. NMI is accepted regardless of the I bit setting. The I bit is set to 1 at the start of an exception-handling sequence. For details, refer to section 5, Interrupt Controller.</p>
6	UI	undefined	R/W	<p>User Bit or Interrupt Mask Bit</p> <p>Can be read or written by software using the LDC, STC, ANDC, ORC, and XORC instructions. This bit cannot be used as an interrupt mask bit in this LSI.</p>
5	H	undefined	R/W	<p>Half-Carry Flag</p> <p>When the ADD.B, ADDX.B, SUB.B, SUBX.B, CMP.B, or NEG.B instruction is executed, this flag is set to 1 if there is a carry or borrow at bit 3, and cleared to 0 otherwise. When the ADD.W, SUB.W, CMP.W, or NEG.W instruction is executed, the H flag is set to 1 if there is a carry or borrow at bit 11, and cleared to 0 otherwise. When the ADD.L, SUB.L, CMP.L, or NEG.L instruction is executed, the H flag is set to 1 if there is a carry or borrow at bit 27, and cleared to 0 otherwise.</p>
4	U	undefined	R/W	<p>User Bit</p> <p>Can be read or written by software using the LDC, STC, ANDC, ORC, and XORC instructions.</p>
3	N	undefined	R/W	<p>Negative Flag</p> <p>Stores the value of the most significant bit of data as a sign bit.</p>

Bit	Bit Name	Initial Value	R/W	Description
2	Z	undefined	R/W	Zero Flag Set to 1 to indicate zero data, and cleared to 0 to indicate non-zero data.
1	V	undefined	R/W	Overflow Flag Set to 1 when an arithmetic overflow occurs, and cleared to 0 at other times.
0	C	undefined	R/W	Carry Flag Set to 1 when a carry occurs, and cleared to 0 otherwise. Used by: <ul style="list-style-type: none"> • Add instructions, to indicate a carry • Subtract instructions, to indicate a borrow • Shift and rotate instructions, to indicate a carry The carry flag is also used as a bit accumulator by bit manipulation instructions.

2.4.5 Multiply-Accumulate Register (MAC)

This 64-bit register stores the results of multiply-and-accumulate operations. It consists of two 32-bit registers denoted MACH and MACL. The lower 10 bits of MACH are valid; the upper bits are a sign extension.

2.4.6 Initial Values of CPU Registers

Reset exception handling loads the CPU's program counter (PC) from the vector table, clears the trace bit in EXR to 0, and sets the interrupt mask bits in CCR and EXR to 1. The other CCR bits and the general registers are not initialized. In particular, the stack pointer (ER7) is not initialized. The stack pointer should therefore be initialized by an MOV.L instruction executed immediately after a reset.

2.5 Data Formats

The H8S/2600 CPU can process 1-bit, 4-bit (BCD), 8-bit (byte), 16-bit (word), and 32-bit (longword) data. Bit-manipulation instructions operate on 1-bit data by accessing bit n ($n = 0, 1, 2, \dots, 7$) of byte operand data. The DAA and DAS decimal-adjust instructions treat byte data as two digits of 4-bit BCD data.

2.5.1 General Register Data Formats

Figure 2.9 shows the data formats in general registers.

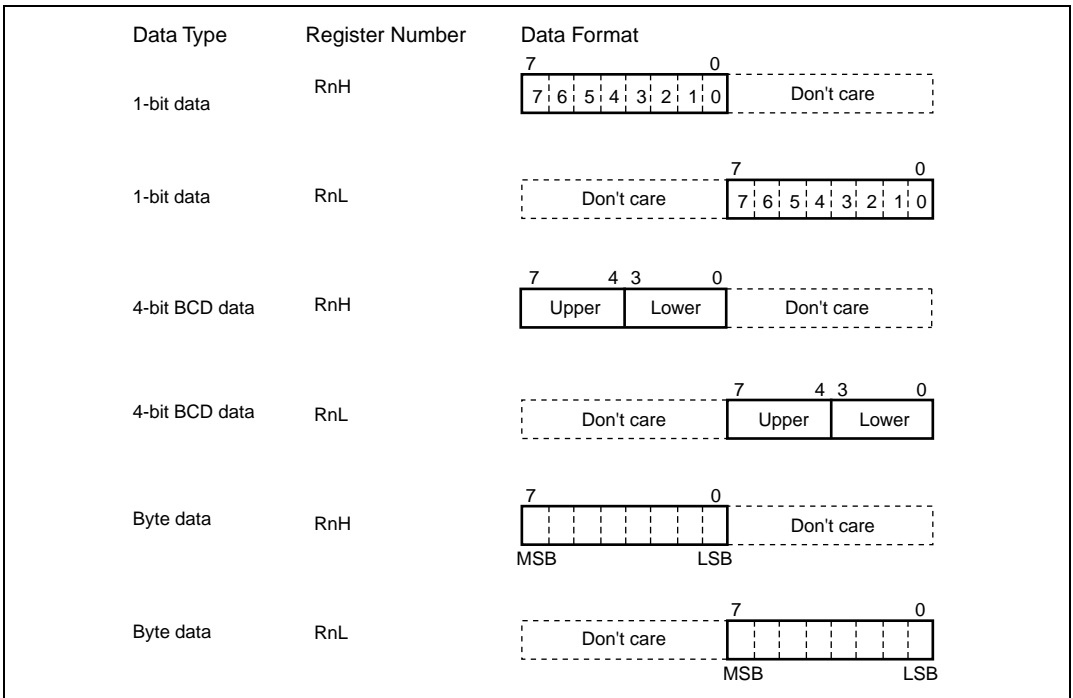

Figure 2.9 General Register Data Formats (1)

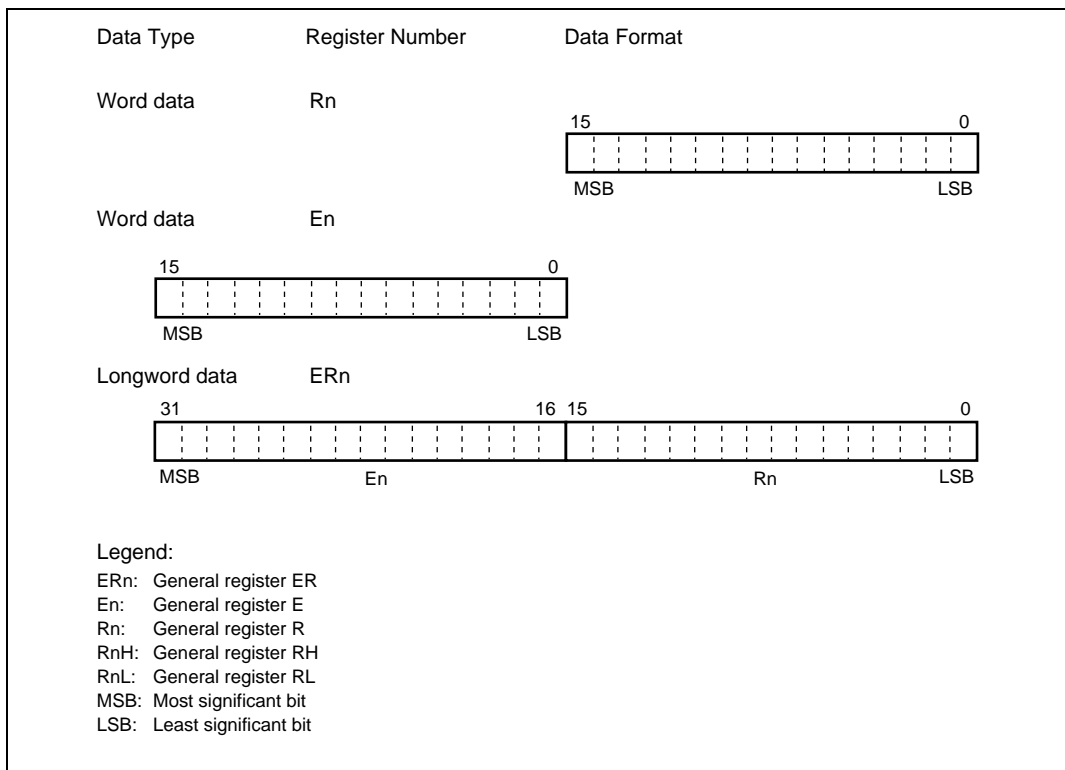

Figure 2.9 General Register Data Formats (2)

2.5.2 Memory Data Formats

Figure 2.10 shows the data formats in memory. The H8S/2600 CPU can access word data and longword data in memory, however word or longword data must begin at an even address. If an attempt is made to access word or longword data at an odd address, an address error does not occur, however the least significant bit of the address is regarded as 0, so access begins the preceding address. This also applies to instruction fetches.

When ER7 is used as an address register to access the stack, the operand size should be word or longword.

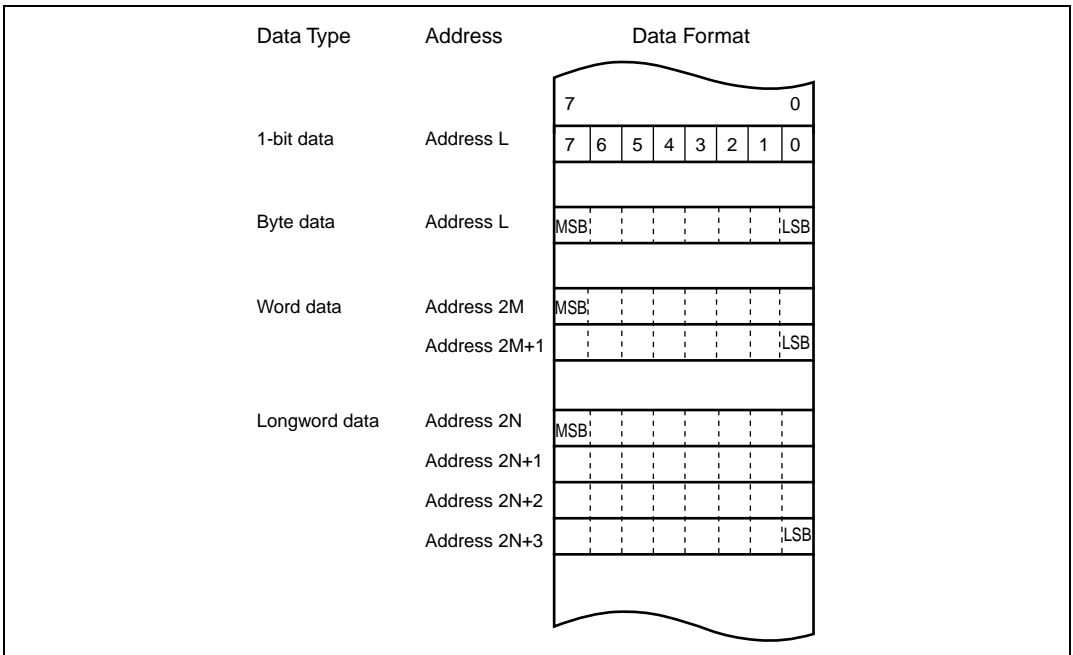

Figure 2.10 Memory Data Formats

2.6 Instruction Set

The H8S/2600 CPU has 69 instructions. The instructions are classified by function in table 2.1.

Table 2.1 Instruction Classification

Function	Instructions	Size	Types
Data transfer	MOV	B/W/L	5
	POP* ¹ , PUSH* ¹	W/L	
	LDM, STM	L	
	MOVFPE* ³ , MOVTPE* ³	B	
Arithmetic operations	ADD, SUB, CMP, NEG	B/W/L	23
	ADDX, SUBX, DAA, DAS	B	
	INC, DEC	B/W/L	
	ADDS, SUBS	L	
	MULXU, DIVXU, MULXS, DIVXS	B/W	
	EXTU, EXTS	W/L	
	TAS* ⁴	B	
	MAC, LDMAC, STMAC, CLRMAC	—	
Logic operations	AND, OR, XOR, NOT	B/W/L	4
Shift	SHAL, SHAR, SHLL, SHLR, ROTL, ROTR, ROTXL, ROTXR	B/W/L	8
Bit manipulation	BSET, BCLR, BNOT, BTST, BLD, BILD, BST, BIST, BAND, BIAND, BOR, BIOR, BXOR, BIXOR	B	14
Branch	Bcc* ² , JMP, BSR, JSR, RTS	—	5
System control	TRAPA, RTE, SLEEP, LDC, STC, ANDC, ORC, XORC, NOP	—	9
Block data transfer	EEMOV	—	1

Total: 69

Notes: B: Byte

W: Word

L: Longword

1. POP.W Rn and PUSH.W Rn are identical to MOV.W @SP+,Rn and MOV.W Rn,@-SP. POP.L ERn and PUSH.L ERn are identical to MOV.L @SP+,ERn and MOV.L ERn,@-SP.
2. Bcc is the general name for conditional branch instructions.
3. Cannot be used in this LSI.
4. Only register ER0, ER1, ER4, or ER5 should be used when using the TAS instruction.

2.6.1 Table of Instructions Classified by Function

Tables 2.3 to 2.10 summarize the instructions in each functional category. The notation used in tables 2.3 to 2.10 is defined below.

Table 2.2 Operation Notation

Symbol	Description
Rd	General register (destination)*
Rs	General register (source)*
Rn	General register*
ERn	General register (32-bit register)
MAC	Multiply-accumulate register (32-bit register)
(EAd)	Destination operand
(EAs)	Source operand
EXR	Extended control register
CCR	Condition-code register
N	N (negative) flag in CCR
Z	Z (zero) flag in CCR
V	V (overflow) flag in CCR
C	C (carry) flag in CCR
PC	Program counter
SP	Stack pointer
#IMM	Immediate data
disp	Displacement
+	Addition
-	Subtraction
×	Multiplication
÷	Division
^	Logical AND
∨	Logical OR
⊕	Logical XOR
→	Move
~	NOT (logical complement)
:8/:16/:24/:32	8-, 16-, 24-, or 32-bit length

Note: * General registers include 8-bit registers (R7H to R0H, R7L to R0L), 16-bit registers (R7 to R0, E7 to E0), and 32-bit registers (ER7 to ER0).

Table 2.3 Data Transfer Instructions

Instruction	Size*	Function
MOV	B/W/L	(EAs) → Rd, Rs → (EAd) Moves data between two general registers or between a general register and memory, or moves immediate data to a general register.
MOVFP	B	Cannot be used in this LSI.
MOVTPE	B	Cannot be used in this LSI.
POP	W/L	@SP+ → Rn Pops a general register from the stack. POP.W Rn is identical to MOV.W @SP+, Rn. POP.L ERn is identical to MOV.L @SP+, ERn.
PUSH	W/L	Rn → @-SP Pushes a general register onto the stack. PUSH.W Rn is identical to MOV.W Rn, @-SP. PUSH.L ERn is identical to MOV.L ERn, @-SP.
LDM	L	@SP+ → Rn (register list) Pops two or more general registers from the stack.
STM	L	Rn (register list) → @-SP Pushes two or more general registers onto the stack.

Note: * Refers to the operand size.

B: Byte

W: Word

L: Longword

Table 2.4 Arithmetic Operations Instructions (1)

Instruction	Size*	Function
ADD SUB	B/W/L	$Rd \pm Rs \rightarrow Rd$, $Rd \pm \#IMM \rightarrow Rd$ Performs addition or subtraction on data in two general registers, or on immediate data and data in a general register (immediate byte data cannot be subtracted from byte data in a general register. Use the SUBX or ADD instruction).
ADDX SUBX	B	$Rd \pm Rs \pm C \rightarrow Rd$, $Rd \pm \#IMM \pm C \rightarrow Rd$ Performs addition or subtraction with carry on byte data in two general registers, or on immediate data and data in a general register.
INC DEC	B/W/L	$Rd \pm 1 \rightarrow Rd$, $Rd \pm 2 \rightarrow Rd$ Increments or decrements a general register by 1 or 2 (Byte operands can be incremented or decremented by 1 only).
ADDS SUBS	L	$Rd \pm 1 \rightarrow Rd$, $Rd \pm 2 \rightarrow Rd$, $Rd \pm 4 \rightarrow Rd$ Adds or subtracts the value 1, 2, or 4 to or from data in a 32-bit register.
DAA DAS	B	Rd decimal adjust $\rightarrow Rd$ Decimal-adjusts an addition or subtraction result in a general register by referring to the CCR to produce 4-bit BCD data.
MULXU	B/W	$Rd \times Rs \rightarrow Rd$ Performs unsigned multiplication on data in two general registers: either 8 bits \times 8 bits \rightarrow 16 bits or 16 bits \times 16 bits \rightarrow 32 bits.
MULXS	B/W	$Rd \times Rs \rightarrow Rd$ Performs signed multiplication on data in two general registers: either 8 bits \times 8 bits \rightarrow 16 bits or 16 bits \times 16 bits \rightarrow 32 bits.
DIVXU	B/W	$Rd \div Rs \rightarrow Rd$ Performs unsigned division on data in two general registers: either 16 bits \div 8 bits \rightarrow 8-bit quotient and 8-bit remainder or 32 bits \div 16 bits \rightarrow 16-bit quotient and 16-bit remainder.

Note: * Refers to the operand size.

B: Byte

W: Word

L: Longword

Table 2.4 Arithmetic Operations Instructions (2)

Instruction	Size*¹	Function
DIVXS	B/W	$Rd \div Rs \rightarrow Rd$ Performs signed division on data in two general registers: either 16 bits \div 8 bits \rightarrow 8-bit quotient and 8-bit remainder or 32 bits \div 16 bits \rightarrow 16-bit quotient and 16-bit remainder.
CMP	B/W/L	$Rd - Rs$, $Rd - \#IMM$ Compares data in a general register with data in another general register or with immediate data, and sets CCR bits according to the result.
NEG	B/W/L	$0 - Rd \rightarrow Rd$ Takes the two's complement (arithmetic complement) of data in a general register.
EXTU	W/L	Rd (zero extension) $\rightarrow Rd$ Extends the lower 8 bits of a 16-bit register to word size, or the lower 16 bits of a 32-bit register to longword size, by padding with zeros on the left.
EXTS	W/L	Rd (sign extension) $\rightarrow Rd$ Extends the lower 8 bits of a 16-bit register to word size, or the lower 16 bits of a 32-bit register to longword size, by extending the sign bit.
TAS* ²	B	$@ERd - 0, 1 \rightarrow (<bit 7> \text{ of } @ERd)$ Tests memory contents, and sets the most significant bit (bit 7) to 1.
MAC	—	$(EAs) \times (EAd) + MAC \rightarrow MAC$ Performs signed multiplication on memory contents and adds the result to the multiply-accumulate register. The following operations can be performed: 16 bits \times 16 bits + 32 bits \rightarrow 32 bits, saturating 16 bits \times 16 bits + 42 bits \rightarrow 42 bits, non-saturating
CLRMAC	—	$0 \rightarrow MAC$ Clears the multiply-accumulate register to zero.
LDMAC STMAC	L	$Rs \rightarrow MAC$, $MAC \rightarrow Rd$ Transfers data between a general register and a multiply-accumulate register.

Note: 1. Refers to the operand size.

B: Byte

W: Word

L: Longword

2. Only register ER0, ER1, ER4, or ER5 should be used when using the TAS instruction.

Table 2.5 Logic Operations Instructions

Instruction	Size*	Function
AND	B/W/L	$Rd \wedge Rs \rightarrow Rd$, $Rd \wedge \#IMM \rightarrow Rd$ Performs a logical AND operation on a general register and another general register or immediate data.
OR	B/W/L	$Rd \vee Rs \rightarrow Rd$, $Rd \vee \#IMM \rightarrow Rd$ Performs a logical OR operation on a general register and another general register or immediate data.
XOR	B/W/L	$Rd \oplus Rs \rightarrow Rd$, $Rd \oplus \#IMM \rightarrow Rd$ Performs a logical exclusive OR operation on a general register and another general register or immediate data.
NOT	B/W/L	$\sim(Rd) \rightarrow (Rd)$ Takes the one's complement (logical complement) of general register contents.

Note: * Refers to the operand size.

B: Byte

W: Word

L: Longword

Table 2.6 Shift Instructions

Instruction	Size*	Function
SHAL SHAR	B/W/L	Rd (shift) → Rd Performs an arithmetic shift on general register contents. 1-bit or 2-bit shifts are possible.
SHLL SHLR	B/W/L	Rd (shift) → Rd Performs a logical shift on general register contents. 1-bit or 2-bit shifts are possible.
ROTL ROTR	B/W/L	Rd (rotate) → Rd Rotates general register contents. 1-bit or 2-bit rotations are possible.
ROTXL ROTXR	B/W/L	Rd (rotate) → Rd Rotates general register contents through the carry flag. 1-bit or 2-bit rotations are possible.

Note: * Refers to the operand size.

B: Byte

W: Word

L: Longword

Table 2.7 Bit Manipulation Instructions (1)

Instruction	Size*	Function
BSET	B	1 → (<bit-No.> of <EAd>) Sets a specified bit in a general register or memory operand to 1. The bit number is specified by 3-bit immediate data or the lower three bits of a general register.
BCLR	B	0 → (<bit-No.> of <EAd>) Clears a specified bit in a general register or memory operand to 0. The bit number is specified by 3-bit immediate data or the lower three bits of a general register.
BNOT	B	~(<bit-No.> of <EAd>) → (<bit-No.> of <EAd>) Inverts a specified bit in a general register or memory operand. The bit number is specified by 3-bit immediate data or the lower three bits of a general register.
BTST	B	~(<bit-No.> of <EAd>) → Z Tests a specified bit in a general register or memory operand and sets or clears the Z flag accordingly. The bit number is specified by 3-bit immediate data or the lower three bits of a general register.
BAND	B	$C \wedge (<bit-No.> \text{ of } <EAd>) \rightarrow C$ ANDs the carry flag with a specified bit in a general register or memory operand and stores the result in the carry flag.
BIAND	B	$C \wedge [\sim(<bit-No.> \text{ of } <EAd>)] \rightarrow C$ ANDs the carry flag with the inverse of a specified bit in a general register or memory operand and stores the result in the carry flag. The bit number is specified by 3-bit immediate data.
BOR	B	$C \vee (<bit-No.> \text{ of } <EAd>) \rightarrow C$ ORs the carry flag with a specified bit in a general register or memory operand and stores the result in the carry flag.
BIOR	B	$C \vee [\sim(<bit-No.> \text{ of } <EAd>)] \rightarrow C$ ORs the carry flag with the inverse of a specified bit in a general register or memory operand and stores the result in the carry flag. The bit number is specified by 3-bit immediate data.

Note: * Refers to the operand size.

B: Byte

Table 2.7 Bit Manipulation Instructions (2)

Instruction	Size*	Function
BXOR	B	$C \oplus (\text{<bit-No.> of <EAd>}) \rightarrow C$ XORs the carry flag with a specified bit in a general register or memory operand and stores the result in the carry flag.
BIXOR	B	$C \oplus [\sim(\text{<bit-No.> of <EAd>})] \rightarrow C$ XORs the carry flag with the inverse of a specified bit in a general register or memory operand and stores the result in the carry flag. The bit number is specified by 3-bit immediate data.
BLD	B	$(\text{<bit-No.> of <EAd>}) \rightarrow C$ Transfers a specified bit in a general register or memory operand to the carry flag.
BILD	B	$\sim(\text{<bit-No.> of <EAd>}) \rightarrow C$ Transfers the inverse of a specified bit in a general register or memory operand to the carry flag. The bit number is specified by 3-bit immediate data.
BST	B	$C \rightarrow (\text{<bit-No.> of <EAd>})$ Transfers the carry flag value to a specified bit in a general register or memory operand.
BIST	B	$\sim C \rightarrow (\text{<bit-No.> of <EAd>})$ Transfers the inverse of the carry flag value to a specified bit in a general register or memory operand. The bit number is specified by 3-bit immediate data.

Note: * Refers to the operand size.

B: Byte

Table 2.8 Branch Instructions

Instruction	Size	Function																																																			
Bcc	—	Branches to a specified address if a specified condition is true. The branching conditions are listed below.																																																			
		<table border="1"> <thead> <tr> <th>Mnemonic</th> <th>Description</th> <th>Condition</th> </tr> </thead> <tbody> <tr> <td>BRA (BT)</td> <td>Always (true)</td> <td>Always</td> </tr> <tr> <td>BRN (BF)</td> <td>Never (false)</td> <td>Never</td> </tr> <tr> <td>BHI</td> <td>High</td> <td>$C \vee Z = 0$</td> </tr> <tr> <td>BLS</td> <td>Low or same</td> <td>$C \vee Z = 1$</td> </tr> <tr> <td>BCC (BHS)</td> <td>Carry clear (high or same)</td> <td>$C = 0$</td> </tr> <tr> <td>BCS (BLO)</td> <td>Carry set (low)</td> <td>$C = 1$</td> </tr> <tr> <td>BNE</td> <td>Not equal</td> <td>$Z = 0$</td> </tr> <tr> <td>BEQ</td> <td>Equal</td> <td>$Z = 1$</td> </tr> <tr> <td>BVC</td> <td>Overflow clear</td> <td>$V = 0$</td> </tr> <tr> <td>BVS</td> <td>Overflow set</td> <td>$V = 1$</td> </tr> <tr> <td>BPL</td> <td>Plus</td> <td>$N = 0$</td> </tr> <tr> <td>BMI</td> <td>Minus</td> <td>$N = 1$</td> </tr> <tr> <td>BGE</td> <td>Greater or equal</td> <td>$N \oplus V = 0$</td> </tr> <tr> <td>BLT</td> <td>Less than</td> <td>$N \oplus V = 1$</td> </tr> <tr> <td>BGT</td> <td>Greater than</td> <td>$Z \vee (N \oplus V) = 0$</td> </tr> <tr> <td>BLE</td> <td>Less or equal</td> <td>$Z \vee (N \oplus V) = 1$</td> </tr> </tbody> </table>	Mnemonic	Description	Condition	BRA (BT)	Always (true)	Always	BRN (BF)	Never (false)	Never	BHI	High	$C \vee Z = 0$	BLS	Low or same	$C \vee Z = 1$	BCC (BHS)	Carry clear (high or same)	$C = 0$	BCS (BLO)	Carry set (low)	$C = 1$	BNE	Not equal	$Z = 0$	BEQ	Equal	$Z = 1$	BVC	Overflow clear	$V = 0$	BVS	Overflow set	$V = 1$	BPL	Plus	$N = 0$	BMI	Minus	$N = 1$	BGE	Greater or equal	$N \oplus V = 0$	BLT	Less than	$N \oplus V = 1$	BGT	Greater than	$Z \vee (N \oplus V) = 0$	BLE	Less or equal	$Z \vee (N \oplus V) = 1$
Mnemonic	Description	Condition																																																			
BRA (BT)	Always (true)	Always																																																			
BRN (BF)	Never (false)	Never																																																			
BHI	High	$C \vee Z = 0$																																																			
BLS	Low or same	$C \vee Z = 1$																																																			
BCC (BHS)	Carry clear (high or same)	$C = 0$																																																			
BCS (BLO)	Carry set (low)	$C = 1$																																																			
BNE	Not equal	$Z = 0$																																																			
BEQ	Equal	$Z = 1$																																																			
BVC	Overflow clear	$V = 0$																																																			
BVS	Overflow set	$V = 1$																																																			
BPL	Plus	$N = 0$																																																			
BMI	Minus	$N = 1$																																																			
BGE	Greater or equal	$N \oplus V = 0$																																																			
BLT	Less than	$N \oplus V = 1$																																																			
BGT	Greater than	$Z \vee (N \oplus V) = 0$																																																			
BLE	Less or equal	$Z \vee (N \oplus V) = 1$																																																			
JMP	—	Branches unconditionally to a specified address.																																																			
BSR	—	Branches to a subroutine at a specified address.																																																			
JSR	—	Branches to a subroutine at a specified address.																																																			
RTS	—	Returns from a subroutine																																																			

Table 2.9 System Control Instructions

Instruction	Size*	Function
TRAPA	—	Starts trap-instruction exception handling.
RTE	—	Returns from an exception-handling routine.
SLEEP	—	Causes a transition to a power-down state.
LDC	B/W	(EAs) → CCR, (EAs) → EXR Moves general register or memory contents or immediate data to CCR or EXR. Although CCR and EXR are 8-bit registers, word-size transfers are performed between them and memory. The upper 8 bits are valid.
STC	B/W	CCR → (EAd), EXR → (EAd) Transfers CCR or EXR contents to a general register or memory. Although CCR and EXR are 8-bit registers, word-size transfers are performed between them and memory. The upper 8 bits are valid.
ANDC	B	CCR ∧ #IMM → CCR, EXR ∧ #IMM → EXR Logically ANDs the CCR or EXR contents with immediate data.
ORC	B	CCR ∨ #IMM → CCR, EXR ∨ #IMM → EXR Logically ORs the CCR or EXR contents with immediate data.
XORC	B	CCR ⊕ #IMM → CCR, EXR ⊕ #IMM → EXR Logically XORs the CCR or EXR contents with immediate data.
NOP	—	PC + 2 → PC Only increments the program counter.

Note: * Refers to the operand size.

B: Byte

W: Word

Table 2.10 Block Data Transfer Instructions

Instruction	Size	Function
EEPMOV.B	—	<pre> if R4L ≠ 0 then Repeat @ER5+ → @ER6+ R4L-1 → R4L Until R4L = 0 else next; </pre>
EEPMOV.W	—	<pre> if R4 ≠ 0 then Repeat @ER5+ → @ER6+ R4-1 → R4 Until R4 = 0 else next; </pre> <p>Transfers a data block. Starting from the address set in ER5, transfers data for the number of bytes set in R4L or R4 to the address location set in ER6.</p> <p>Execution of the next instruction begins as soon as the transfer is completed.</p>

2.6.2 Basic Instruction Formats

The H8S/2600 CPU instructions consist of 2-byte (1-word) units. An instruction consists of an operation field (op field), a register field (r field), an effective address extension (EA field), and a condition field (cc).

Figure 2.11 shows examples of instruction formats.

- **Operation Field**
Indicates the function of the instruction, the addressing mode, and the operation to be carried out on the operand. The operation field always includes the first four bits of the instruction. Some instructions have two operation fields.
- **Register Field**
Specifies a general register. Address registers are specified by 3 bits, and data registers by 3 bits or 4 bits. Some instructions have two register fields. Some have no register field.
- **Effective Address Extension**
8, 16, or 32 bits specifying immediate data, an absolute address, or a displacement.
- **Condition Field**
Specifies the branching condition of Bcc instructions.

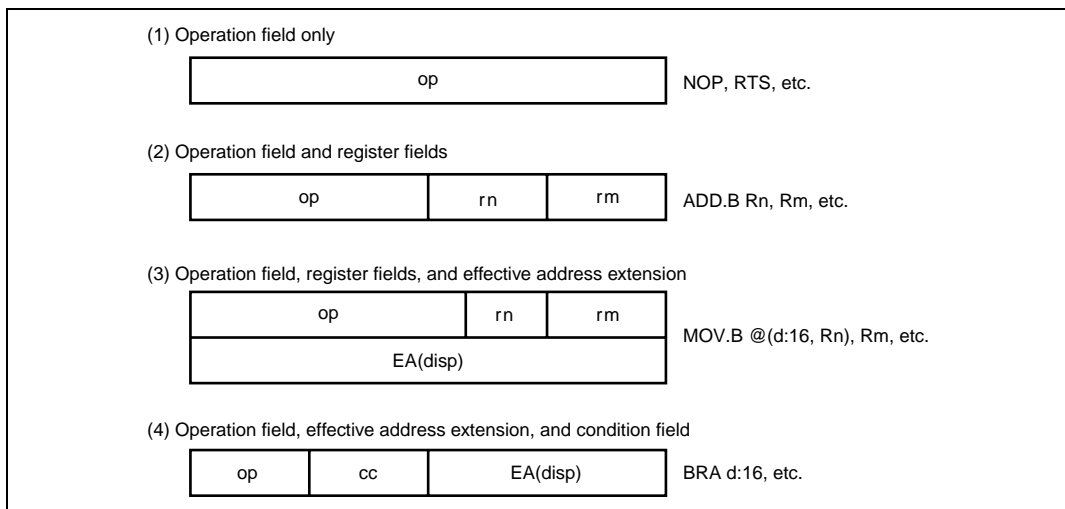

Figure 2.11 Instruction Formats (Examples)

2.7 Addressing Modes and Effective Address Calculation

The H8S/2600 CPU supports the eight addressing modes listed in table 2.11. Each instruction uses a subset of these addressing modes. Arithmetic and logic instructions can use the register direct and immediate modes. Data transfer instructions can use all addressing modes except program-counter relative and memory indirect. Bit manipulation instructions use register direct, register indirect, or the absolute addressing mode to specify an operand, and register direct (BSET, BCLR, BNOT, and BTST instructions) or immediate (3-bit) addressing mode to specify a bit number in the operand.

Table 2.11 Addressing Modes

No.	Addressing Mode	Symbol
1	Register direct	Rn
2	Register indirect	@ERn
3	Register indirect with displacement	@(d:16,ERn)/@(d:32,ERn)
4	Register indirect with post-increment Register indirect with pre-decrement	@ERn+ @-ERn
5	Absolute address	@aa:8/@aa:16/@aa:24/@aa:32
6	Immediate	#xx:8/#xx:16/#xx:32
7	Program-counter relative	@(d:8,PC)/@(d:16,PC)
8	Memory indirect	@@aa:8

2.7.1 Register Direct—Rn

The register field of the instruction specifies an 8-, 16-, or 32-bit general register containing the operand. R0H to R7H and R0L to R7L can be specified as 8-bit registers. R0 to R7 and E0 to E7 can be specified as 16-bit registers. ER0 to ER7 can be specified as 32-bit registers.

2.7.2 Register Indirect—@ERn

The register field of the instruction code specifies an address register (ERn) which contains the address of the operand on memory. If the address is a program instruction address, the lower 24 bits are valid and the upper 8 bits are all assumed to be 0 (H'00).

2.7.3 Register Indirect with Displacement—@(d:16, ERn) or @(d:32, ERn)

A 16-bit or 32-bit displacement contained in the instruction is added to an address register (ERn) specified by the register field of the instruction, and the sum gives the address of a memory operand. A 16-bit displacement is sign-extended when added.

2.7.4 Register Indirect with Post-Increment or Pre-Decrement—@ERn+ or @-ERn

Register indirect with post-increment—@ERn+: The register field of the instruction code specifies an address register (ERn) which contains the address of a memory operand. After the operand is accessed, 1, 2, or 4 is added to the address register contents and the sum is stored in the address register. The value added is 1 for byte access, 2 for word transfer instruction, or 4 for longword transfer instruction. For the word or longword transfer instructions, the register value should be even.

Register indirect with pre-decrement—@-ERn: The value 1, 2, or 4 is subtracted from an address register (ERn) specified by the register field in the instruction code, and the result is the address of a memory operand. The result is also stored in the address register. The value subtracted is 1 for byte access, 2 for word transfer instruction, or 4 for longword transfer instruction. For the word or longword transfer instructions, the register value should be even.

2.7.5 Absolute Address—@aa:8, @aa:16, @aa:24, or @aa:32

The instruction code contains the absolute address of a memory operand. The absolute address may be 8 bits long (@aa:8), 16 bits long (@aa:16), 24 bits long (@aa:24), or 32 bits long (@aa:32). Table 2.12 indicates the accessible absolute address ranges.

To access data, the absolute address should be 8 bits (@aa:8), 16 bits (@aa:16), or 32 bits (@aa:32) long. For an 8-bit absolute address, the upper 24 bits are all assumed to be 1 (H'FFFF). For a 16-bit absolute address the upper 16 bits are a sign extension. A 32-bit absolute address can access the entire address space.

A 24-bit absolute address (@aa:24) indicates the address of a program instruction. The upper 8 bits are all assumed to be 0 (H'00).

Table 2.12 Absolute Address Access Ranges

Absolute Address		Normal Mode*	Advanced Mode
Data address	8 bits (@aa:8)	H'FF00 to H'FFFF	H'FFFF00 to H'FFFFFF
	16 bits (@aa:16)	H'0000 to H'FFFF	H'000000 to H'007FFF, H'FF8000 to H'FFFFFF
	32 bits (@aa:32)		H'000000 to H'FFFFFF
Program instruction address	24 bits (@aa:24)		

Note: Normal mode is not available in this LSI.

2.7.6 Immediate—#xx:8, #xx:16, or #xx:32

The instruction contains 8-bit (#xx:8), 16-bit (#xx:16), or 32-bit (#xx:32) immediate data as an operand.

The ADDS, SUBS, INC, and DEC instructions contain immediate data implicitly. Some bit manipulation instructions contain 3-bit immediate data in the instruction code, specifying a bit number. The TRAPA instruction contains 2-bit immediate data in its instruction code, specifying a vector address.

2.7.7 Program-Counter Relative—@(d:8, PC) or @(d:16, PC)

This mode is used in the Bcc and BSR instructions. An 8-bit or 16-bit displacement contained in the instruction is sign-extended and added to the 24-bit PC contents to generate a branch address. Only the lower 24 bits of this branch address are valid; the upper 8 bits are all assumed to be 0 (H'00). The PC value to which the displacement is added is the address of the first byte of the next instruction, so the possible branching range is -126 to +128 bytes (-63 to +64 words) or -32766 to +32768 bytes (-16383 to +16384 words) from the branch instruction. The resulting value should be an even number.

2.7.8 Memory Indirect—@@aa:8

This mode can be used by the JMP and JSR instructions. The instruction code contains an 8-bit absolute address specifying a memory operand. This memory operand contains a branch address. The upper bits of the absolute address are all assumed to be 0, so the address range is 0 to 255 (H'0000 to H'00FF in normal mode, H'000000 to H'0000FF in advanced mode). In normal mode, the memory operand is a word operand and the branch address is 16 bits long. In advanced mode, the memory operand is a longword operand, the first byte of which is assumed to be 0 (H'00).

Note that the first part of the address range is also the exception vector area. For further details, refer to section 4, Exception Handling.

If an odd address is specified in word or longword memory access, or as a branch address, the least significant bit is regarded as 0, causing data to be accessed or instruction code to be fetched at the address preceding the specified address (For further information, see section 2.5.2, Memory Data Formats).

Note: Normal mode is not available in this LSI.

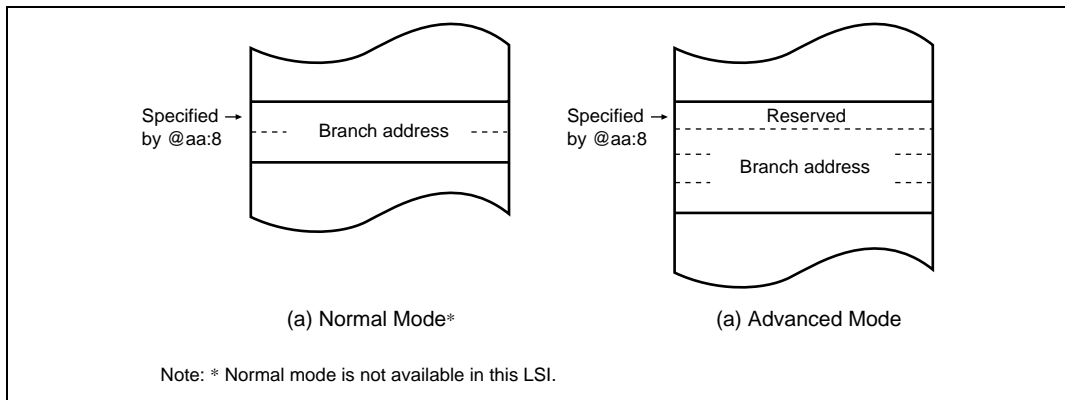

Figure 2.12 Branch Address Specification in Memory Indirect Mode

2.7.9 Effective Address Calculation

Table 2.13 indicates how effective addresses are calculated in each addressing mode. In normal mode the upper 8 bits of the effective address are ignored in order to generate a 16-bit address.

Note: Normal mode is not available in this LSI.

Table 2.13 Effective Address Calculation (1)



No	Addressing Mode and Instruction Format	Effective Address Calculation	Effective Address (EA)								
1	Register direct(Rn) 		Operand is general register contents.								
2	Register indirect(@ERn) 										
3	Register indirect with displacement @d:(d:16,ERn) or @:(d:32,ERn) 										
4	Register indirect with post-increment or pre-decrement •Register indirect with post-increment @ERn+  •Register indirect with pre-decrement @-ERn 	 <table border="1" data-bbox="457 821 698 901"> <thead> <tr> <th>Operand Size</th> <th>Offset</th> </tr> </thead> <tbody> <tr> <td>Byte</td> <td>1</td> </tr> <tr> <td>Word</td> <td>2</td> </tr> <tr> <td>Longword</td> <td>4</td> </tr> </tbody> </table>	Operand Size	Offset	Byte	1	Word	2	Longword	4	 
Operand Size	Offset										
Byte	1										
Word	2										
Longword	4										

Table 2.13 Effective Address Calculation (2)

No	Addressing Mode and Instruction Format	Effective Address Calculation	Effective Address (EA)
5	Absolute address @aa:8		
	@aa:16		
	@aa:24		
	@aa:32		
6	Immediate #xx:8/#xx:16/#xx:32		Operand is immediate data.
7	Program-counter relative @(d:8,PC)@(d:16,PC)		
8	Memory indirect @aa:8 • Normal mode*		
	• Advanced mode		

Note: * Normal mode is not available in this LSI.

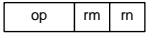
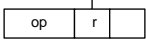
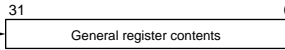
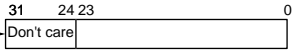
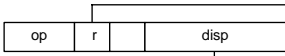
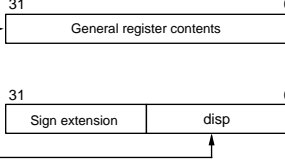
2.8 Processing States

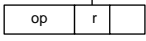
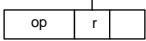
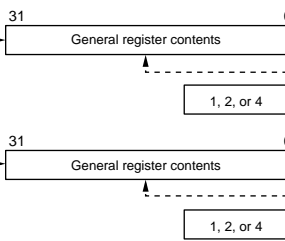
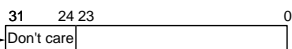
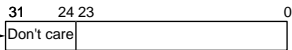
The H8S/2600 CPU has five main processing states: the reset state, exception handling state, program execution state, bus-released state, and power-down state. Figure 2.13 indicates the state transitions.

- Reset State

In this state, the CPU and all on-chip peripheral modules are initialized and not operating. When the $\overline{\text{RES}}$ input goes low, all current processing stops and the CPU enters the reset state. All interrupts are masked in the reset state. Reset exception handling starts when the $\overline{\text{RES}}$ signal changes from low to high. For details, refer to section 4, Exception Handling.

The reset state can also be entered by a watchdog timer overflow.

- Exception-Handling State

The exception-handling state is a transient state that occurs when the CPU alters the normal processing flow due to an exception source, such as a reset, trace, interrupt, or trap instruction. The CPU fetches a start address (vector) from the exception vector table and branches to that address. For further details, refer to section 4, Exception Handling.

- Program Execution State

In this state, the CPU executes program instructions in sequence.

- Bus-Released State

The bus has been released in response to a bus request from a bus master other than the CPU. While the bus is released, the CPU halts operations.

- Program stop state

This is a power-down state in which the CPU stops operating. The program stop state occurs when a SLEEP instruction is executed or the CPU enters hardware standby mode. For further details, refer to section 21, Power-Down Modes.

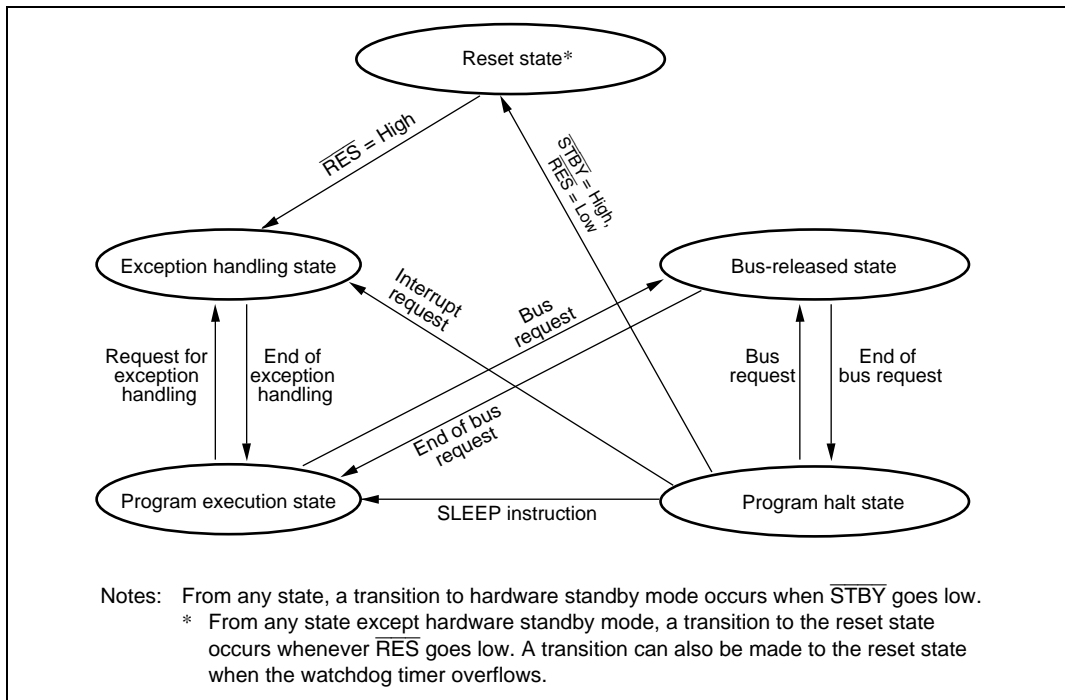

Figure 2.13 State Transitions

2.9 Usage Note

2.9.1 Notes on Using the Bit Operation Instruction

Instructions BSET, BCLR, BNOT, BST, and BIST read data in byte units, and write data in byte units after bit operation. Therefore, attention must be paid when these instructions are used for ports or registers including write-only bits.

Instruction BCLR can be used to clear the flag in the internal I/O register to 0. If it is obvious that the flag has been set to 1 by the interrupt processing routine, it is unnecessary to read the flag beforehand.

Section 3 MCU Operating Modes

3.1 Operating Mode Selection

This LSI supports only operating mode 7, that is, the advanced single-chip mode. The operating mode is determined by the setting of the mode pins (MD2 to MD0). Only mode 7 can be used in this LSI. Therefore, all mode pins must be fixed high, as shown in table 3.1. Do not change the mode pin settings during operation.

Table 3.1 MCU Operating Mode Selection

MCU Operating Mode	MD2	MD1	MD0	CPU Operating Mode	Description	On-Chip ROM	External Data Bus	
							Initial Width	Max. Width
7	1	1	1	Advanced mode	Single-chip mode	Enabled	—	—

3.2 Register Descriptions

The following registers are related to the operating mode.

- Mode control register (MDCR)
- System control register (SYSCR)

3.2.1 Mode Control Register (MDCR)

Bit	Bit Name	Initial Value	R/W	Descriptions
7	—	1	R/W	Reserved Only 1 should be written to this bit.
6 to 3	—	All 0	—	Reserved These bits are always read as 0 and cannot be modified.
2	MDS2	—	R	Mode select 2 to 0
1	MDS1	—	R	These bits indicate the input levels at pins MD2 to MD0 (the current operating mode). Bits MDS2 to MDS0 correspond to MD2 to MD0. MDS2 to MDS0 are read-only bits and they cannot be written to. The mode pin (MD2 to MD0) input levels are latched into these bits when MDCR is read. These latches are canceled by a reset.
0	MDS0	—	R	

3.2.2 System Control Register (SYSCR)

SYSCR is an 8-bit readable/writable register that selects saturating or non-saturating calculation for the MAC instruction, selects the interrupt control mode and the detected edge for NMI, and enables or disables on-chip RAM.

Bit	Bit Name	Initial Value	R/W	Descriptions
7	MACS	0	R/W	MAC Saturation Selects either saturating or non-saturating calculation for the MAC instruction. 0: Non-saturating calculation for the MAC instruction 1: Saturating calculation for the MAC instruction
6	—	0	—	Reserved This bit is always read as 0 and cannot be modified.
5	INTM1	0	R/W	These bits select the control mode of the interrupt controller. For details of the interrupt control modes, see section 5.6, Interrupt Control Modes and Interrupt Operation. 00: Interrupt control mode 0 01: Setting prohibited 10: Interrupt control mode 2 11: Setting prohibited
4	INTM0	0	R/W	
3	NMIEG	0	R/W	NMI Edge Select Selects the valid edge of the NMI interrupt input. 0: An interrupt is requested at the falling edge of NMI input 1: An interrupt is requested at the rising edge of NMI input
2, 1	—	All 0	—	Reserved These bits are always read as 0 and cannot be modified.
0	RAME	1	R/W	RAM Enable Enables or disables on-chip RAM. The RAME bit is initialized when the reset status is released. 0: On-chip RAM is disabled 1: On-chip RAM is enabled

3.3 Pin Functions in Each Operating Mode

The CPU can access a 16-Mbyte address space in advanced mode. The on-chip ROM is enabled, however external addresses cannot be accessed.

All I/O ports are available for use as input-output ports.

3.4 Address Map

Figure 3.1 shows the address map in each operating mode.

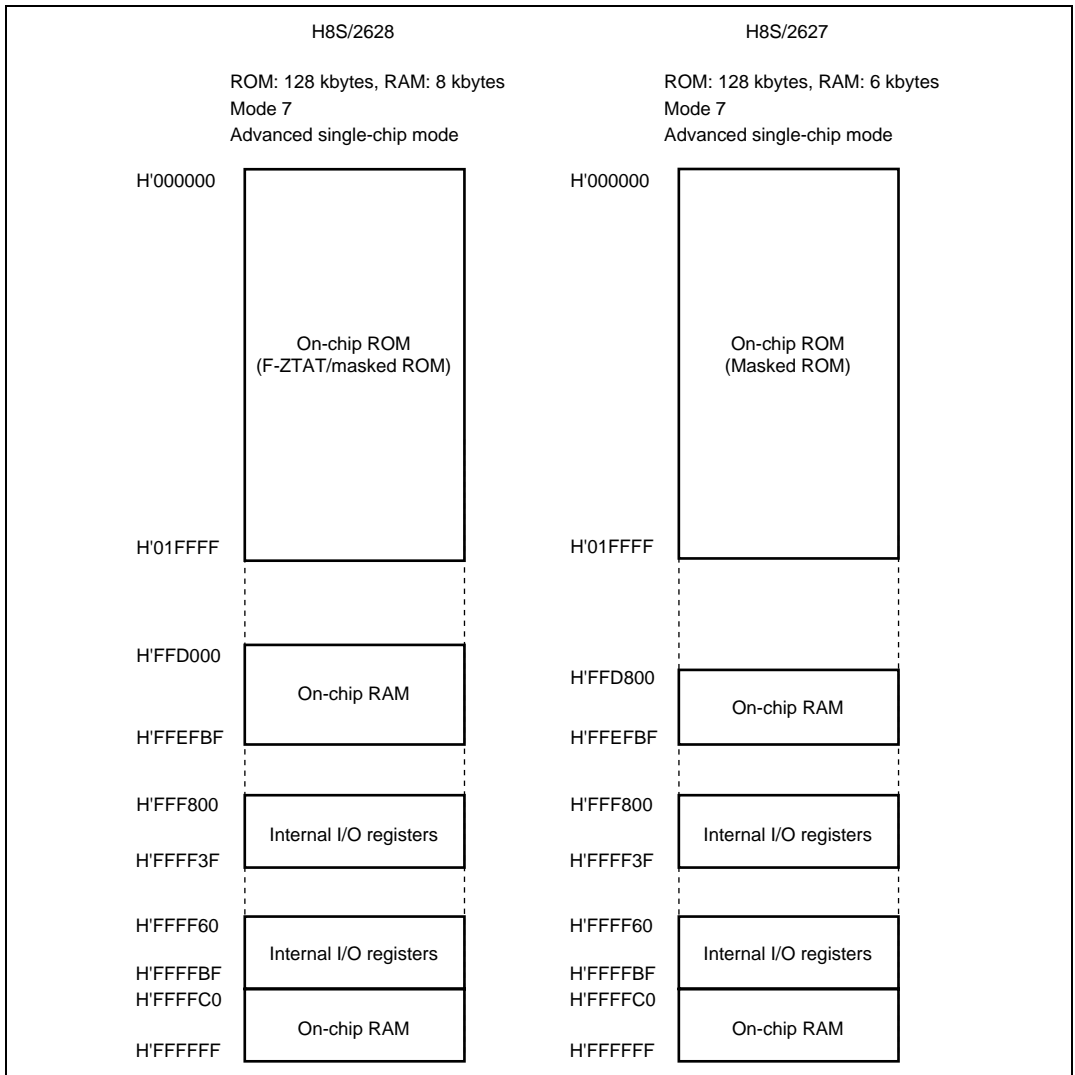



Figure 3.1 Address Map

Section 4 Exception Handling

4.1 Exception Handling Types and Priority

As shown in table 4.1, exception handling may be caused by a reset, trace, interrupt, or trap instruction. Exception handling is prioritized as shown in table 4.1. If two or more exceptions occur simultaneously, they are accepted and processed in order of priority. Exception sources, the stack structure, and operation of the CPU vary depending on the interrupt control mode. For details on the interrupt control mode, refer to section 5, Interrupt Controller.

Table 4.1 Exception Types and Priority

Priority	Exception Type	Start of Exception Handling
High 	Reset	Starts immediately after a low-to-high transition at the $\overline{\text{RES}}$ pin, or when the watchdog timer overflows. The CPU enters the reset state when the $\overline{\text{RES}}$ pin is low.
	Trace ^{*1}	Starts when execution of the current instruction or exception handling ends, if the trace (T) bit in EXR is set to 1.
	Direct transition	Starts when a direction transition occurs as the result of SLEEP instruction execution.
	Interrupt	Starts when execution of the current instruction or exception handling ends, if an interrupt request has been issued. ^{*2}
Low	Trap instruction ^{*3}	Started by execution of a trap instruction (TRAPA).

- Notes:
1. Traces are enabled only in interrupt control mode 2. Trace exception handling is not executed after execution of an RTE instruction.
 2. Interrupt detection is not performed on completion of ANDC, ORC, XORC, or LDC instruction execution, or on completion of reset exception handling.
 3. Trap instruction exception handling requests are accepted at all times in program execution state.

4.2 Exception Sources and Exception Vector Table

Different vector addresses are assigned to different exception sources. Table 4.2 lists the exception sources and their vector addresses. Since the usable modes differ depending on the product, for details on each product, refer to section 3, MCU Operating Modes.

Table 4.2 Exception Handling Vector Table

Exception Source	Vector Number	Vector Address*1		
		Normal Mode	Advanced Mode	
Power-on reset	0	H'0000 to H'0001	H'0000 to H'0003	
Manual reset *2	1	H'0002 to H'0003	H'0004 to H'0007	
Reserved for system use	2	H'0004 to H'0005	H'0008 to H'000B	
	3	H'0006 to H'0007	H'000C to H'000F	
	4	H'0008 to H'0019	H'0010 to H'0013	
Trace	5	H'000A to H'000B	H'0014 to H'0017	
Interrupt (direct transitions) *2	6	H'000C to H'000D	H'0018 to H'001B	
Interrupt (NMI)	7	H'000E to H'000F	H'001C to H'001F	
Trap instruction (#0)	8	H'0010 to H'0011	H'0020 to H'0023	
	(#1)	9	H'0012 to H'0013	H'0024 to H'0027
	(#2)	10	H'0014 to H'0015	H'0028 to H'002B
	(#3)	11	H'0016 to H'0017	H'002C to H'002F
Reserved for system use	12	H'0018 to H'0019	H'0030 to H'0033	
	13	H'001A to H'001B	H'0034 to H'0037	
	14	H'001C to H'001D	H'0038 to H'003B	
	15	H'001E to H'001F	H'003C to H'003F	
External interrupt	IRQ0	16	H'0020 to H'0021	H'0040 to H'0043
	IRQ1	17	H'0022 to H'0023	H'0044 to H'0047
	IRQ2	18	H'0024 to H'0025	H'0048 to H'004B
	IRQ3	19	H'0026 to H'0027	H'004C to H'004F
	IRQ4	20	H'0028 to H'0029	H'0050 to H'0053
	IRQ5	21	H'002A to H'002B	H'0054 to H'0057
Reserved for system use	22	H'002C to H'002D	H'0058 to H'005B	
	23	H'002E to H'002F	H'005C to H'005F	
Internal interrupt*3	24	H'0030 to H'0031	H'0060 to H'0063	
	127	H'00FE to H'00FF	H'01FC to H'01FF	

Notes: 1. Lower 16 bits of the address.

2. Not available in this LSI.

3. For details of internal interrupt vectors, see section 5.5, Interrupt Exception Handling Vector Table.

4.3 Reset

A reset has the highest exception priority.

When the $\overline{\text{RES}}$ pin goes low, all processing halts and this LSI enters the reset state. To ensure that this LSI is reset, hold the $\overline{\text{RES}}$ pin low for at least 20 ms at power-up. To reset the chip during operation, hold the $\overline{\text{RES}}$ pin low for at least 20 states. A reset initializes the internal state of the CPU and the registers of on-chip peripheral modules.

The chip can also be reset by overflow of the watchdog timer. For details, see section 13, Watchdog Timer.

The interrupt control mode is 0 immediately after reset.

4.3.1 Reset Exception Handling

When the $\overline{\text{RES}}$ pin goes high after being held low for the necessary period, this LSI starts reset exception handling as follows:

1. The internal state of the CPU and the registers of the on-chip peripheral modules are initialized, the T bit in EXR is cleared to 0, and the I bit in EXR and CCR is set to 1.
2. The reset exception handling vector address is read and transferred to the PC, and program execution starts from the address indicated by the PC.

Figures 4.1 and 4.2 show examples of the reset sequence.

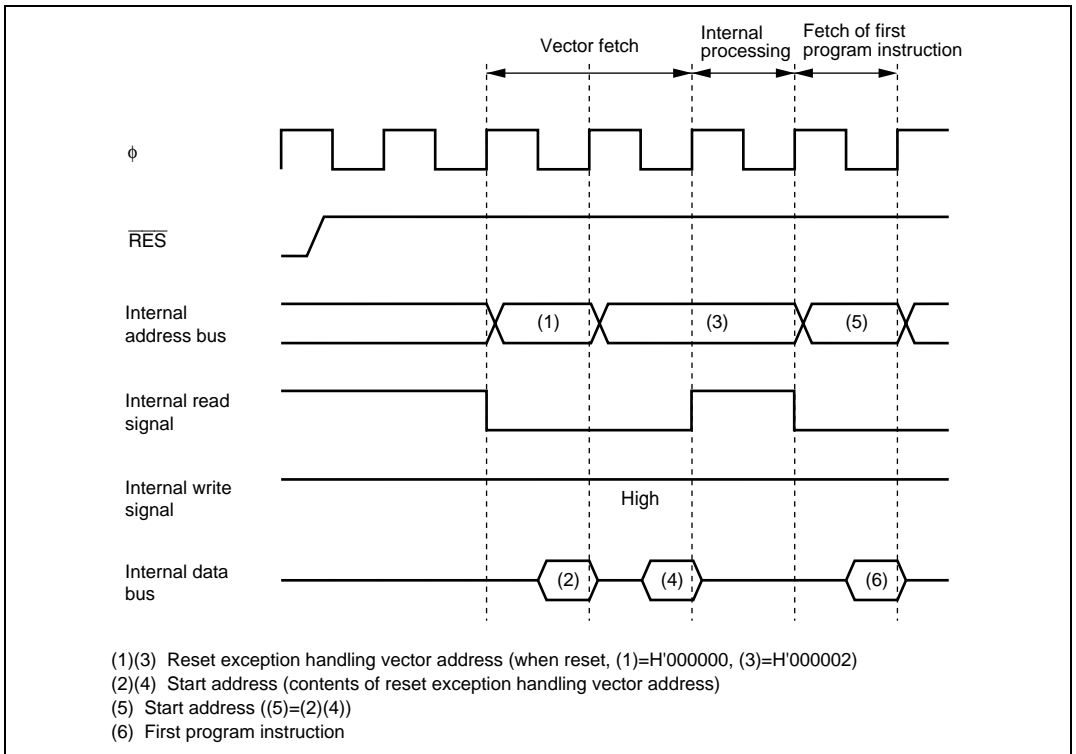

Figure 4.1 Reset Sequence
(Advanced Mode with On-Chip ROM Enabled)

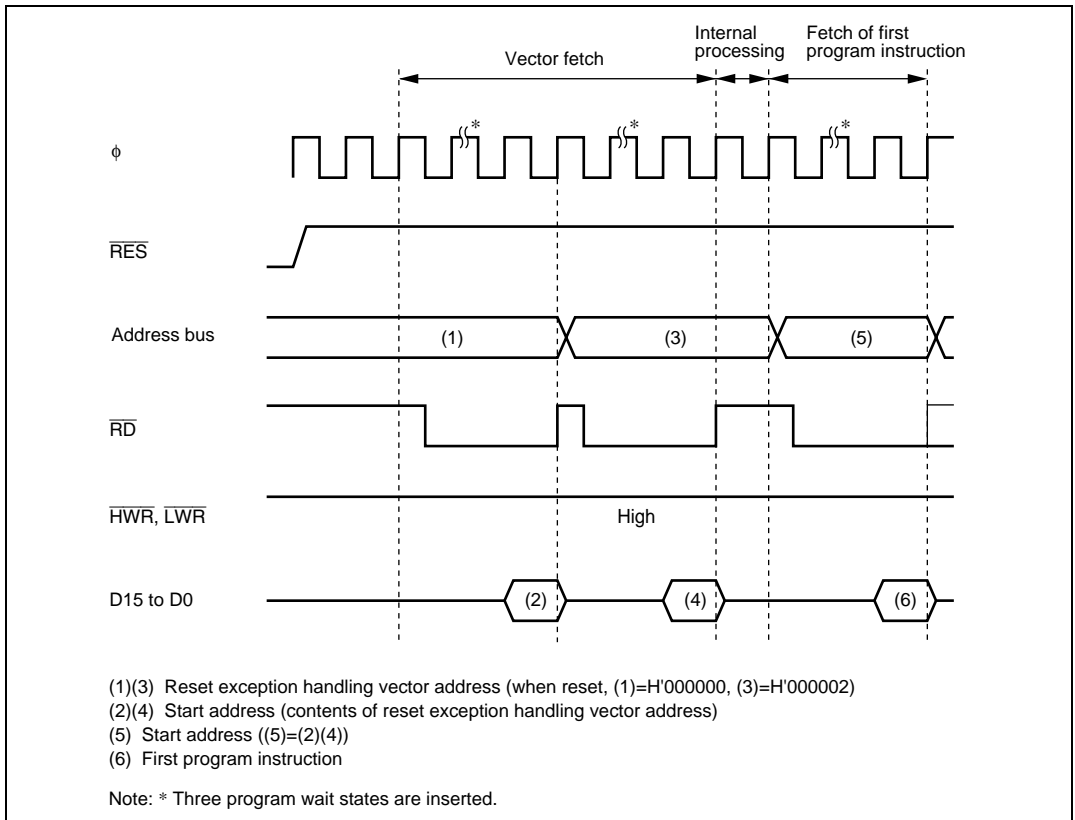

Figure 4.2 Reset Sequence

(Advanced Mode with On-chip ROM Disabled: Not Available in this LSI)

4.3.2 Interrupts after Reset

If an interrupt is accepted immediately after a reset and before the stack pointer (SP) is initialized, the PC and CCR will not be saved correctly, leading to a program crash. To prevent this, all interrupt requests, including NMI, are disabled immediately after a reset exception handling is executed. Since the first instruction of a program is always executed immediately after the reset, make sure that this instruction initializes the stack pointer (example: `MOV.L #xx: 32, SP`).

4.3.3 State of On-Chip Peripheral Modules after Reset Release

After reset release, MSTPCRA to MSTPCRC are initialized to H'3F, H'FF, and H'FF, respectively, and all modules except the DTC enter module stop mode. Consequently, on-chip peripheral module registers cannot be read or written to. Register reading and writing is enabled when the module stop mode is cancelled.

4.4 Traces

Traces are enabled in interrupt control mode 2. Trace mode is not activated in interrupt control mode 0, irrespective of the state of the T bit. For details of interrupt control modes, see section 5, Interrupt Controller.

If the T bit in EXR is set to 1, trace mode is activated. In trace mode, a trace exception occurs on completion of each instruction. Trace mode is not affected by interrupt mask bit in CCR. Table 4.3 shows the states of CCR and EXR after execution of trace exception handling. Trace mode is cancelled by clearing the T bit in EXR to 0 with the trace exception handling. The T bit saved on the stack retains its value of 1, and when control is returned from the trace exception handling routine by the RTE instruction, trace mode resumes. Trace exception handling is not carried out after execution of the RTE instruction.

Interrupts are accepted even within the trace exception handling routine.

Table 4.3 Statuses of CCR and EXR after Trace Exception Handling

Interrupt Control Mode	CCR		EXR	
	I	UI	I2 to I0	T
0	Trace exception handling cannot be used.			
2	1	—	—	0

Legend:

1: Set to 1

0: Cleared to 0

—: Retains value prior to execution

4.5 Interrupts

Interrupts are controlled by the interrupt controller. The interrupt controller has two interrupt control modes and can assign interrupts other than NMI to eight priority/mask levels to enable multiplexed interrupt control. The source to start interrupt exception handling and the vector address differ depending on the product. For details, refer to section 5, Interrupt Controller.

Interrupt exception handling is conducted as follows:

1. The values in the program counter (PC), condition code register (CCR), and extended control register (EXR) are saved to the stack.
2. The interrupt mask bit is updated and the T bit is cleared to 0.
3. A vector address corresponding to the interrupt source is generated, the start address is loaded from the vector table to the PC, and program execution begins from that address.

4.6 Trap Instruction

Trap instruction exception handling starts when a TRAPA instruction is executed. Trap instruction exception handling can be executed at all times in the program execution state.

Trap instruction exception handling is conducted as follows:

1. The values in the program counter (PC), condition code register (CCR), and extended control register (EXR) are saved to the stack.
2. The interrupt mask bit is updated and the T bit is cleared to 0.
3. A vector address corresponding to the interrupt source is generated, the start address is loaded from the vector table to the PC, and program execution starts from that address.

The TRAPA instruction fetches a start address from a vector table entry corresponding to a vector number from 0 to 3, as specified in the instruction code.

Table 4.4 shows the statuses of CCR and EXR after execution of trap instruction exception handling.

Table 4.4 Statuses of CCR and EXR after Trap Instruction Exception Handling

Interrupt Control Mode	CCR		EXR	
	I	UI	I2 to I0	T
0	1	—	—	—
2	1	—	—	0

Legend:

1: Set to 1

0: Cleared to 0

—: Retains value prior to execution

4.8 Usage Note

When accessing word data or longword data, this LSI assumes that the lowest address bit is 0. The stack should always be accessed by word transfer instruction or longword transfer instruction, and the value of the stack pointer (SP: ER7) should always be kept even. Use the following instructions to save registers:

```
PUSH.W   Rn    (or MOV.W Rn, @-SP)
PUSH.L   ERn   (or MOV.L ERn, @-SP)
```

Use the following instructions to restore registers:

```
POP.W    Rn    (or MOV.W @SP+, Rn)
POP.L    ERn   (or MOV.L @SP+, ERn)
```

Setting SP to an odd value may lead to a malfunction. Figure 4.4 shows an example of what happens when the SP value is odd.

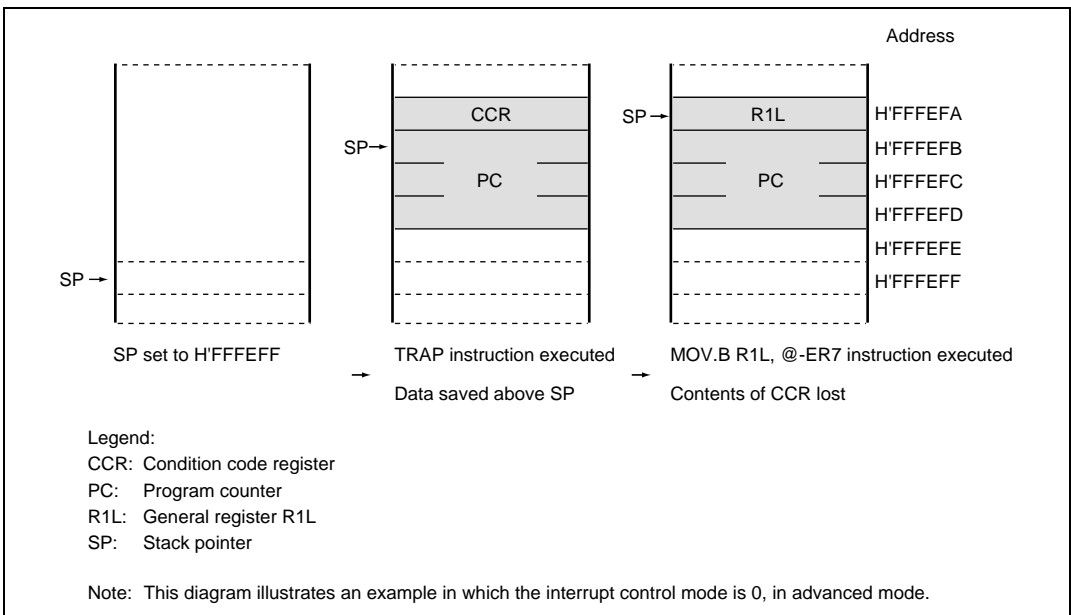

Figure 4.4 Operation when SP Value Is Odd

Section 5 Interrupt Controller

5.1 Features

- Two interrupt control modes
 - Any of two interrupt control modes can be set by means of the INTM1 and INTM0 bits in the system control register (SYSCR).
- Priorities settable with IPR
 - An interrupt priority register (IPR) is provided for setting interrupt priorities. Eight priority levels can be set for each module for all interrupts except NMI. NMI is assigned the highest priority level of 8, and can be accepted at all times.
- Independent vector addresses
 - All interrupt sources are assigned independent vector addresses, making it unnecessary for the source to be identified in the interrupt handling routine.
- Seven external interrupts
 - NMI is the highest-priority interrupt, and is accepted at all times. Rising edge or falling edge can be selected for NMI. Falling edge, rising edge, or both edge detection, or level sensing, can be selected for IRQ5 to IRQ0.
- DTC control
 - The DTC can be activated by an interrupt request.

A block diagram of the interrupt controller is shown in figure 5.1.

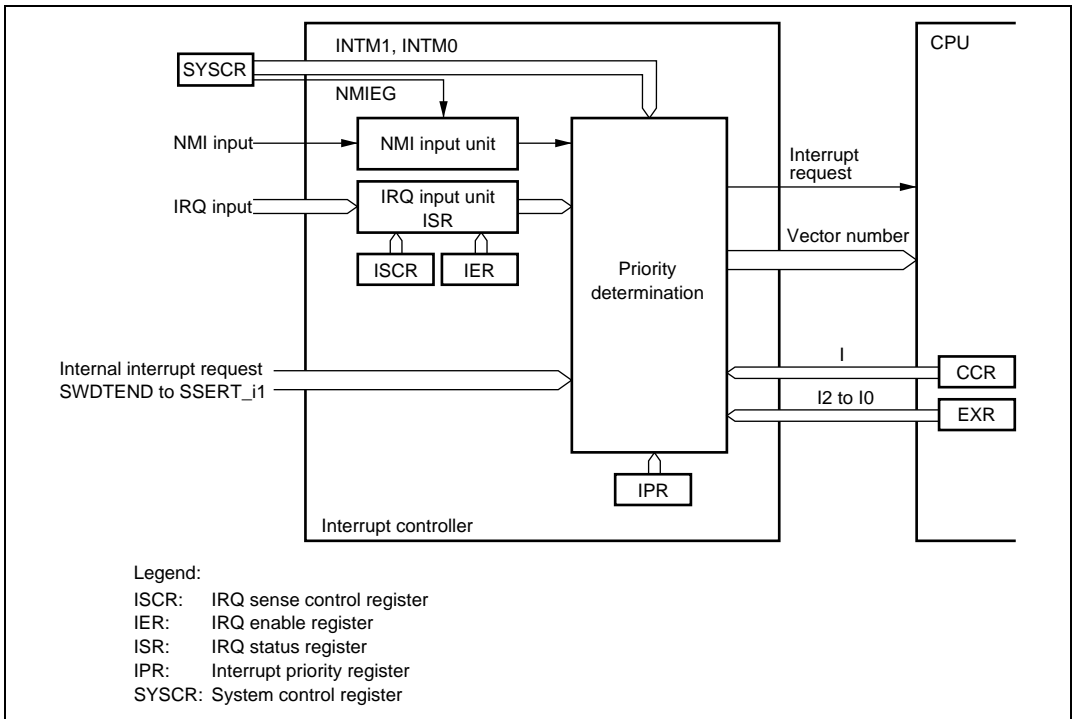

Figure 5.1 Block Diagram of Interrupt Controller

5.2 Input/Output Pins

Table 5.1 summarizes the pins of the interrupt controller.

Table 5.1 Pin Configuration

Name	I/O	Function
NMI	Input	Nonmaskable external interrupt Rising or falling edge can be selected.
$\overline{\text{IRQ5}}$	Input	Maskable external interrupts Rising, falling, or both edges, or level sensing, can be selected.
$\overline{\text{IRQ4}}$	Input	
$\overline{\text{IRQ3}}$	Input	
$\overline{\text{IRQ2}}$	Input	
$\overline{\text{IRQ1}}$	Input	
$\overline{\text{IRQ0}}$	Input	

5.3 Register Descriptions

The interrupt controller has the following registers. For the system control register (SYSCR), refer to section 3.2.2, System Control Register (SYSCR).

- System control register (SYSCR)
- IRQ sense control register H (ISCRH)
- IRQ sense control register L (ISCR L)
- IRQ enable register (IER)
- IRQ status register (ISR)
- Interrupt priority register A (IPRA)
- Interrupt priority register B (IPRB)
- Interrupt priority register C (IPRC)
- Interrupt priority register D (IPRD)
- Interrupt priority register E (IPRE)
- Interrupt priority register F (IPRF)
- Interrupt priority register G (IPRG)
- Interrupt priority register H (IPRH)
- Interrupt priority register I (IPRI)
- Interrupt priority register J (IPRJ)
- Interrupt priority register K (IPRK)
- Interrupt priority register L (IPRL)

- Interrupt priority register M (IPRM)

5.3.1 Interrupt Priority Registers A to M (IPRA to IPRM)

The IPR registers are thirteen 8-bit readable/writable registers that set priorities (levels 7 to 0) for interrupts other than NMI.

The correspondence between interrupt sources and IPR settings is shown in table 5.2. Setting a value in the range from H'7 to H'0 in the 3-bit groups of bits 2 to 0 and 6 to 4 sets the priority of the corresponding interrupt.

Bit	Bit Name	Initial Value	R/W	Description
7	—	0	—	Reserved These bits are always read as 0.
6	IPR6	1	R/W	Sets the priority of the corresponding interrupt source. 000: Priority level 0 (Lowest) 001: Priority level 1 010: Priority level 2 011: Priority level 3 100: Priority level 4 101: Priority level 5 110: Priority level 6 111: Priority level 7 (Highest)
5	IPR5	1	R/W	
4	IPR4	1	R/W	
3	—	0	—	
2	IPR2	1	R/W	Sets the priority of the corresponding interrupt source. 000: Priority level 0 (Lowest) 001: Priority level 1 010: Priority level 2 011: Priority level 3 100: Priority level 4 101: Priority level 5 110: Priority level 6 111: Priority level 7 (Highest)
1	IPR1	1	R/W	
0	IPR0	1	R/W	

5.3.2 IRQ Enable Register (IER)

IER is an 8-bit readable/writable register that controls the enabling and disabling of interrupt requests IRQ5 to IRQ0.

Bit	Bit Name	Initial Value	R/W	Description
7, 6	—	All 0	R/W	Reserved Only 0 should be written to these bits.
5	IRQ5E	0	R/W	IRQ5 Enable The IRQ5 interrupt request is enabled when this bit is 1.
4	IRQ4E	0	R/W	IRQ4 Enable The IRQ4 interrupt request is enabled when this bit is 1.
3	IRQ3E	0	R/W	IRQ3 Enable The IRQ3 interrupt request is enabled when this bit is 1.
2	IRQ2E	0	R/W	IRQ2 Enable The IRQ2 interrupt request is enabled when this bit is 1.
1	IRQ1E	0	R/W	IRQ1 Enable The IRQ1 interrupt request is enabled when this bit is 1.
0	IRQ0E	0	R/W	IRQ0 Enable The IRQ0 interrupt request is enabled when this bit is 1.

5.3.3 IRQ Sense Control Registers H and L (ISCRH, ISCR L)

The ISCR registers are 16-bit readable/writable registers that select the source that generates an interrupt request at pins $\overline{\text{IRQ5}}$ to $\overline{\text{IRQ0}}$.

- ISCRH

Bit	Bit Name	Initial Value	R/W	Description
15 to 12	—	All 0	R/W	Reserved Only 0 should be written to these bits.
11	IRQ5SCB	0	R/W	IRQ5 Sense Control B
10	IRQ5SCA	0	R/W	IRQ5 Sense Control A 00: Interrupt request generated at $\overline{\text{IRQ5}}$ input level low 01: Interrupt request generated at falling edge of $\overline{\text{IRQ5}}$ input 10: Interrupt request generated at rising edge of $\overline{\text{IRQ5}}$ input 11: Interrupt request generated at both falling and rising edges of $\overline{\text{IRQ5}}$ input
9	IRQ4SCB	0	R/W	IRQ4 Sense Control B
8	IRQ4SCA	0	R/W	IRQ4 Sense Control A 00: Interrupt request generated at $\overline{\text{IRQ4}}$ input level low 01: Interrupt request generated at falling edge of $\overline{\text{IRQ4}}$ input 10: Interrupt request generated at rising edge of $\overline{\text{IRQ4}}$ input 11: Interrupt request generated at both falling and rising edges of $\overline{\text{IRQ4}}$ input

- ISCRL

Bit	Bit Name	Initial Value	R/W	Description
7	IRQ3SCB	0	R/W	IRQ3 Sense Control B
6	IRQ3SCA	0	R/W	IRQ3 Sense Control A
				00: Interrupt request generated at $\overline{\text{IRQ3}}$ input level low
				01: Interrupt request generated at falling edge of $\overline{\text{IRQ3}}$ input
				10: Interrupt request generated at rising edge of $\overline{\text{IRQ3}}$ input
				11: Interrupt request generated at both falling and rising edges of $\overline{\text{IRQ3}}$ input
5	IRQ2SCB	0	R/W	IRQ2 Sense Control B
4	IRQ2SCA	0	R/W	IRQ2 Sense Control A
				00: Interrupt request generated at $\overline{\text{IRQ2}}$ input level low
				01: Interrupt request generated at falling edge of $\overline{\text{IRQ2}}$ input
				10: Interrupt request generated at rising edge of $\overline{\text{IRQ2}}$ input
				11: Interrupt request generated at both falling and rising edges of $\overline{\text{IRQ2}}$ input
3	IRQ1SCB	0	R/W	IRQ1 Sense Control B
2	IRQ1SCA	0	R/W	IRQ1 Sense Control A
				00: Interrupt request generated at $\overline{\text{IRQ1}}$ input level low
				01: Interrupt request generated at falling edge of $\overline{\text{IRQ1}}$ input
				10: Interrupt request generated at rising edge of $\overline{\text{IRQ1}}$ input
				11: Interrupt request generated at both falling and rising edges of $\overline{\text{IRQ1}}$ input

Bit	Bit Name	Initial Value	R/W	Description
1	IRQ0SCB	0	R/W	IRQ0 Sense Control B
0	IRQ0SCA	0	R/W	IRQ0 Sense Control A
				00: Interrupt request generated at $\overline{\text{IRQ0}}$ input level low
				01: Interrupt request generated at falling edge of $\overline{\text{IRQ0}}$ input
				10: Interrupt request generated at rising edge of $\overline{\text{IRQ0}}$ input
				11: Interrupt request generated at both falling and rising edges of $\overline{\text{IRQ0}}$ input

5.3.4 IRQ Status Register (ISR)

ISR is an 8-bit readable/writable register that indicates the status of IRQ5 to IRQ0 interrupt requests.

Bit	Bit Name	Initial Value	R/W	Description
7, 6	—	All 0	R/W	Reserved Only 0 should be written to these bits.
5	IRQ5F	0	R/W	[Setting condition]
4	IRQ4F	0	R/W	<ul style="list-style-type: none"> When the interrupt source selected by the ISCR registers occurs
3	IRQ3F	0	R/W	
2	IRQ2F	0	R/W	
1	IRQ1F	0	R/W	[Clearing conditions]
0	IRQ0F	0	R/W	<ul style="list-style-type: none"> Cleared by reading IRQnF flag when IRQnF = 1, then writing 0 to IRQnF flag When interrupt exception handling is executed when low-level detection is set and $\overline{\text{IRQn}}$ input is high When IRQn interrupt exception handling is executed when falling, rising, or both-edge detection is set When the DTC is activated by an IRQn interrupt, and the DISEL bit in MRB of the DTC is cleared to 0

5.4 Interrupt Sources

5.4.1 External Interrupts

There are seven external interrupts: NMI and IRQ5 to IRQ0. These interrupts can be used to restore this LSI from software standby mode.

NMI Interrupt: NMI is the highest-priority interrupt, and is always accepted by the CPU regardless of the interrupt control mode or the status of the CPU interrupt mask bits. The NMIEG bit in SYSCR can be used to select whether an interrupt is requested at a rising edge or a falling edge on the NMI pin.

IRQ5 to IRQ0 Interrupts: Interrupts IRQ5 to IRQ0 are requested by an input signal at pins $\overline{\text{IRQ}}5$ to $\overline{\text{IRQ}}0$. Interrupts IRQ5 to IRQ0 have the following features:

- Using ISCR, it is possible to select whether an interrupt is generated by a low level, falling edge, rising edge, or both edges, at pins $\overline{\text{IRQ}}5$ to $\overline{\text{IRQ}}0$.
- Enabling or disabling of interrupt requests IRQ5 to IRQ0 can be selected with IER.
- The interrupt priority level can be set with IPR.
- The status of interrupt requests IRQ5 to IRQ0 is indicated in ISR. ISR flags can be cleared to 0 by software.

The detection of IRQ5 to IRQ0 interrupts does not depend on whether the relevant pin has been set for input or output. However, when a pin is used as an external interrupt input pin, do not clear the corresponding DDR to 0; and use the pin as an I/O pin for another function.

A block diagram of interrupts IRQ5 to IRQ0 is shown in figure 5.2.

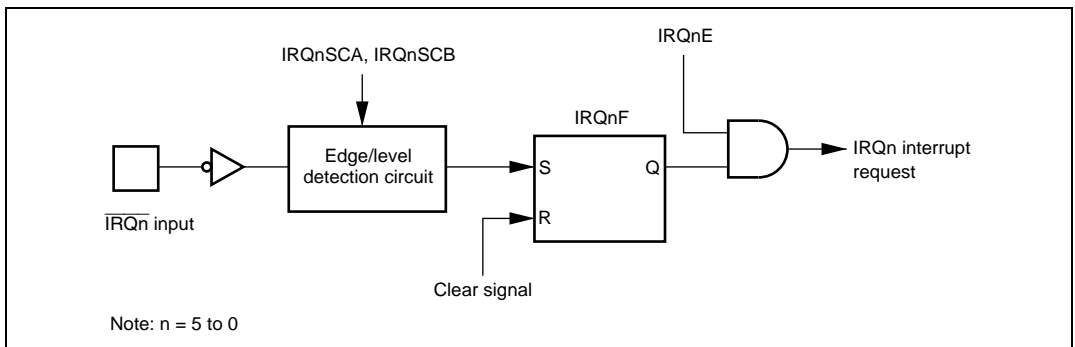

Figure 5.2 Block Diagram of Interrupts IRQ5 to IRQ0

5.4.2 Internal Interrupts

The sources for internal interrupts from on-chip peripheral modules have the following features:

- For each on-chip peripheral module there are flags that indicate the interrupt request status, and enable bits that select enabling or disabling of these interrupts. If both of these are set to 1 for a particular interrupt source, an interrupt request is issued to the interrupt controller.
- The interrupt priority level can be set by means of IPR.
- The DTC can be activated by a TPU, SCI, or other interrupt request.
- When the DTC is activated by an interrupt request, it is not affected by the interrupt control mode or CPU interrupt mask bit.

5.5 Interrupt Exception Handling Vector Table

Table 5.2 shows interrupt exception handling sources, vector addresses, and interrupt priorities.

For default priorities, the lower the vector number, the higher the priority. Priorities among modules can be set by means of IPR. Modules set at the same priority will conform to their default priorities. Priorities within a module are fixed.

Table 5.2 Interrupt Sources, Vector Addresses, and Interrupt Priorities

Interrupt Source	Origin of Interrupt Source	Vector Number	Vector Address*		Priority
			Advanced Mode	IPR	
External pin	NMI	7	H'001C		↑ High
	IRQ0	16	H'0040	IPRA6 to IPRA4	
	IRQ1	17	H'0044	IPRA2 to IPRA0	
	IRQ2	18	H'0048	IPRB6 to IPRB4	
	IRQ3	19	H'004C		
	IRQ4	20	H'0050	IPRB2 to IPRB0	
	IRQ5	21	H'0054		
—	Reserved for system use	22	H'0058		
		23	H'005C		
DTC	SWDTEND	24	H'0060	IPRC2 to IPRC0	
Watchdog timer 0	WOVI0	25	H'0064	IPRD6 to IPRD4	
PC break control	PC break	27	H'006C	IPRE6 to IPRE4	
A/D	ADI	28	H'0070	IPRE2 to IPRE0	
TPU channel 0	TGIA_0	32	H'0080	IPRF6 to IPRF4	
	TGIB_0	33	H'0084		
	TGIC_0	34	H'0088		
	TGID_0	35	H'008C		
	TCIV_0	36	H'0090		
TPU channel 1	TGIA_1	40	H'00A0	IPRF2 to IPRF0	
	TGIB_1	41	H'00A4		
	TCIV_1	42	H'00A8		
	TCIU_1	43	H'00AC		
TPU channel 2	TGIA_2	44	H'00B0	IPRG6 to IPRG4	
	TGIB_2	45	H'00B4		
	TCIV_2	46	H'00B8		
	TCIU_2	47	H'00BC		↓ Low

Interrupt Source	Origin of Interrupt Source	Vector Number	Vector Address*	IPR	Priority
			Advanced Mode		
TPU channel 3	TGIA_3	48	H'00C0	IPRG2 to IPRG0	High ↑
	TGIB_3	49	H'00C4		
	TGIC_3	50	H'00C8		
	TGID_3	51	H'00CC		
	TCIV_3	52	H'00D0		
TPU channel 4	TGIA_4	56	H'00E0	IPRH6 to IPRH4	
	TGIB_4	57	H'00E4		
	TCIV_4	58	H'00E8		
	TCIU_4	59	H'00EC		
TPU channel 5	TGIA_5	60	H'00F0	IPRH2 to IPRH0	
	TGIB_5	61	H'00F4		
	TCIV_5	62	H'00F8		
	TCIU_5	63	H'00FC		
8-bit timer channel 0	CMIA_0	64	H'0100	IPRI6 to IPRI4	
	CMIB_0	65	H'0104		
	OVI_0	66	H'0108		
8-bit timer channel 1	CMIA_1	68	H'0110	IPRI2 to IPRI0	
	CMIB_1	69	H'0114		
	OVI_1	70	H'0118		
SCI channel 0	ERI_0	80	H'0140	IPRJ2 to IPRJ0	
	RXI_0	81	H'0144		
	TXI_0	82	H'0148		
	TEI_0	83	H'014C		
SCI channel 2	ERI_2	88	H'0160	IPRK2 to IPRK0	Low ↓
	RXI_2	89	H'0164		
	TXI_2	90	H'0168		
	TEI_2	91	H'016C		

Interrupt Source	Origin of Interrupt Source	Vector Number	Vector Address*	IPR	Priority
			Advanced Mode		
8-bit timer channel 2	CMIA_2	92	H'0170	IPRL6 to IPRL4	High ↑
	CMIB_2	93	H'0174		
	OVI_2	94	H'0178		
8-bit timer channel 3	CMIA_3	96	H'0180		
	CMIB_3	97	H'0184		
	OVI_3	98	H'0188		
HCAN	ERS0, OVR0	104	H'01A0	IPRM6 to IPRM4	
	RM0	105	H'01A4		
	RM1	106	H'01A8		
	SLE0	107	H'01AC		
SSU channel 0	SSEr_i0	108	H'01B0	IPRM2 to IPRM0	
	SSRx_i0	109	H'01B4		
	SSTx_i0	110	H'01B8		
SSU channel 1	SSERT_i1	111	H'01BC		Low

Note: * Lower 16 bits of the start address.

5.6 Interrupt Control Modes and Interrupt Operation

The interrupt controller has two modes: interrupt control mode 0 and interrupt control mode 2. Interrupt operations differ depending on the interrupt control mode. The interrupt control mode is selected by SYSCR. Table 5.3 shows the differences between interrupt control mode 0 and interrupt control mode 2.

Table 5.3 Interrupt Control Modes

Interrupt Control Mode	Priority Setting Registers	Interrupt Mask Bits	Description
0	Default	I	The priorities of interrupt sources are fixed at the default settings. Interrupt sources, except for NMI, are masked by the I bit.
2	IPR	I2 to I0	8 priority levels other than NMI can be set with IPR. 8-level interrupt mask control is performed by bits I2 to I0.

5.6.1 Interrupt Control Mode 0

In interrupt control mode 0, interrupt requests other than for NMI are masked by the I bit in CCR in the CPU. Figure 5.3 shows a flowchart of the interrupt acceptance operation in this case.

1. If an interrupt source occurs when the corresponding interrupt enable bit is set to 1, an interrupt request is sent to the interrupt controller.
2. If the I bit in CCR is set to 1, only an NMI interrupt is accepted, and other interrupt requests are held pending. If the I bit is cleared, an interrupt request is accepted.
3. When interrupt requests are sent to the interrupt controller, the interrupt with the highest priority according to the interrupt priority levels is selected and other interrupt requests are held pending.
4. When the CPU accepts an interrupt request, it starts interrupt exception handling after execution of the current instruction has been completed.
5. The PC and CCR are saved to the stack area by interrupt exception handling. The PC saved on the stack shows the address of the first instruction to be executed after returning from the interrupt handling routine.
6. Next, the I bit in CCR is set to 1. This masks all interrupts except NMI.

7. The CPU generates a vector address for the accepted interrupt and starts execution of the interrupt handling routine at the address indicated by the contents of the vector address in the vector table.

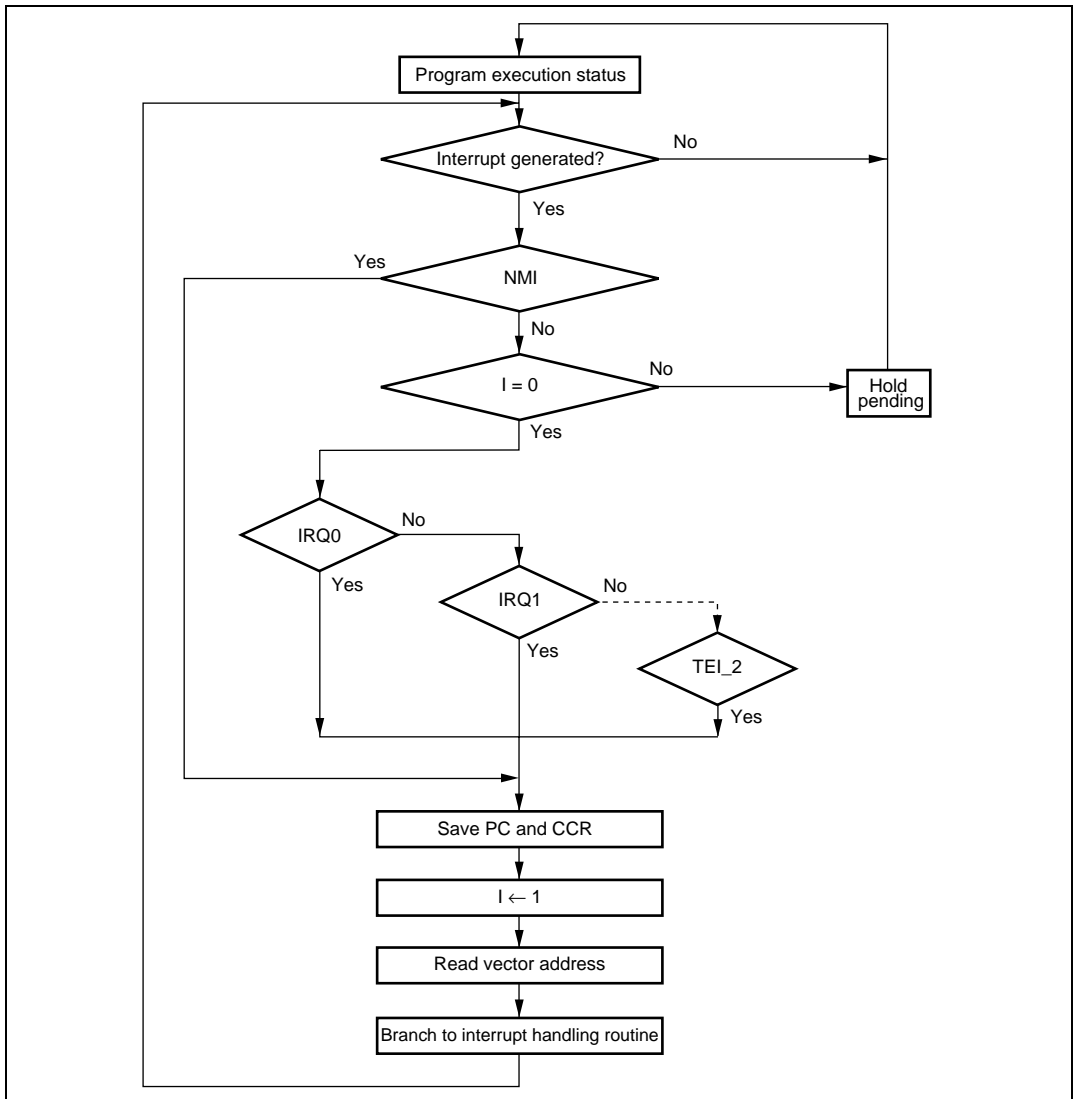

Figure 5.3 Flowchart of Procedure Up to Interrupt Acceptance in Interrupt Control Mode 0

5.6.2 Interrupt Control Mode 2

In interrupt control mode 2, mask control is applied to eight levels for interrupt requests other than NMI by comparing the EXR interrupt mask level (I2 to I0 bits) in the CPU and the IPR setting. Figure 5.4 shows a flowchart of the interrupt acceptance operation in this case.

1. If an interrupt source occurs when the corresponding interrupt enable bit is set to 1, an interrupt request is sent to the interrupt controller.
2. When interrupt requests are sent to the interrupt controller, the interrupt with the highest priority according to the interrupt priority levels set in IPR is selected, and lower-priority interrupt requests are held pending. If a number of interrupt requests with the same priority are generated at the same time, the interrupt request with the highest priority according to the priority system shown in table 5.2 is selected.
3. Next, the priority of the selected interrupt request is compared with the interrupt mask level set in EXR. An interrupt request with a priority no higher than the mask level set at that time is held pending, and only an interrupt request with a priority higher than the interrupt mask level is accepted.
4. When the CPU accepts an interrupt request, it starts interrupt exception handling after execution of the current instruction has been completed.
5. The PC, CCR, and EXR are saved to the stack area by interrupt exception handling. The PC saved on the stack shows the address of the first instruction to be executed after returning from the interrupt handling routine.
6. The T bit in EXR is cleared to 0. The interrupt mask level is rewritten with the priority level of the accepted interrupt. If the accepted interrupt is NMI, the interrupt mask level is set to H'7.
7. The CPU generates a vector address for the accepted interrupt and starts execution of the interrupt handling routine at the address indicated by the contents of the vector address in the vector table.

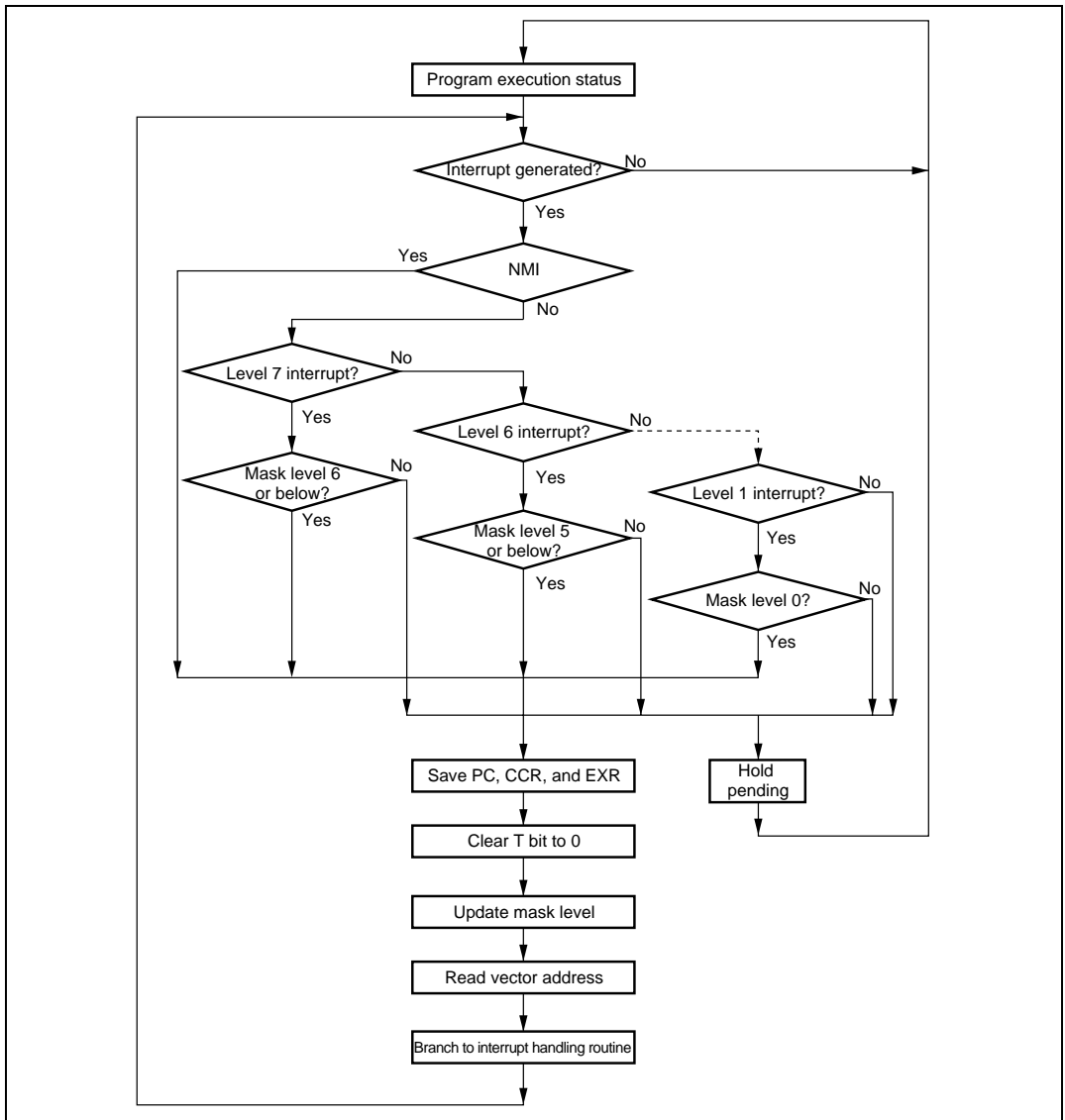

Figure 5.4 Flowchart of Procedure Up to Interrupt Acceptance in Control Mode 2

5.6.3 Interrupt Exception Handling Sequence

Figure 5.5 shows the interrupt exception handling sequence. The example shown is for the case where interrupt control mode 0 is set in advanced mode, and the program area and stack area are in on-chip memory.

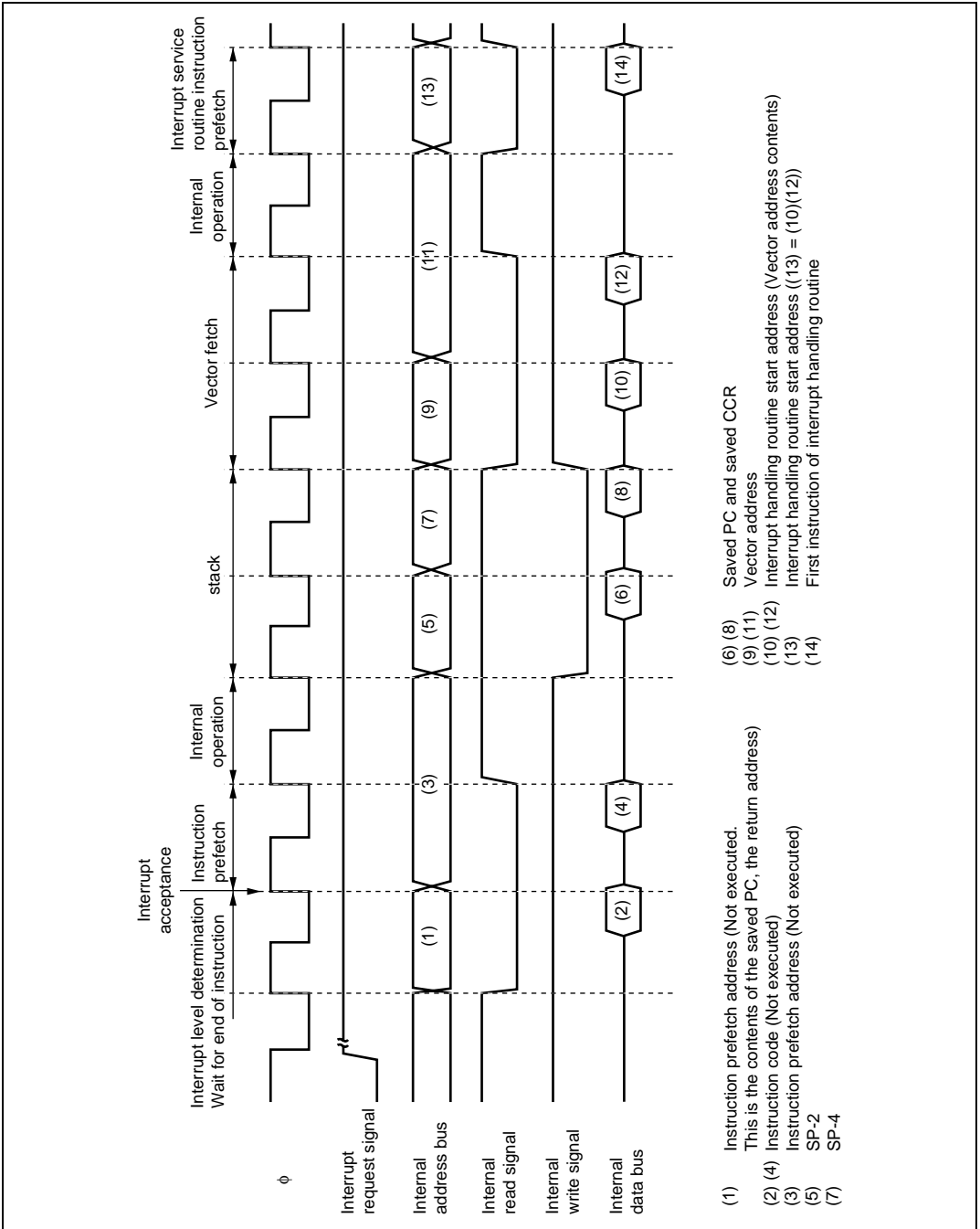

Figure 5.5 Interrupt Exception Handling

5.6.4 Interrupt Response Times

Table 5.4 shows interrupt response times—the interval between generation of an interrupt request and execution of the first instruction in the interrupt handling routine. The execution status symbols used in table 5.4 are explained in table 5.5.

This LSI is capable of fast word transfer to on-chip memory, has the program area in on-chip ROM and the stack area in on-chip RAM, enabling high-speed processing.

Table 5.4 Interrupt Response Times

No.	Execution Status	Normal Mode* ⁵		Advanced Mode	
		Interrupt control mode 0	Interrupt control mode 2	Interrupt control mode 0	Interrupt control mode 2
1	Interrupt priority determination* ¹	3	3	3	3
2	Number of wait states until executing instruction ends* ²	19 to 1+2·S _I	19 to 1+2·S _I	19 to 1+2·S _I	19 to 1+2·S _I
3	PC, CCR, EXR stack save	2·S _K	3·S _K	2·S _K	3·S _K
4	Vector fetch	S _I	S _I	2·S _I	2·S _I
5	Instruction fetch* ³	2·S _I	2·S _I	2·S _I	2·S _I
6	Internal processing* ⁴	2	2	2	2
Total (using on-chip memory)		31 to 11	32 to 12	32 to 12	33 to 13

- Notes: 1. Two states in case of internal interrupt.
 2. Refers to MULXS and DIVXS instructions.
 3. Prefetch after interrupt acceptance and interrupt handling routine prefetch.
 4. Internal processing after interrupt acceptance and internal processing after vector fetch.
 5. Not available in this LSI.

Table 5.5 Number of States in Interrupt Handling Routine Execution Status

Symbol		Object of Access				
		Internal Memory	External Device*			
			8-Bit Bus		16-Bit Bus	
		2-State Access	3-State Access	2-State Access	3-State Access	
Instruction fetch	S _I	1	4	6+2m	2	3+m
Branch address read	S _J					
Stack manipulation	S _K					

Legend:

m: Number of wait states in an external device access.

Note: * Not available in this LSI.

5.6.5 DTC Activation by Interrupt

The DTC can be activated by an interrupt. For details, see section 8, Data Transfer Controller (DTC).

5.7 Usage Notes

5.7.1 Conflict between Interrupt Generation and Disabling

When an interrupt enable bit is cleared to 0 to disable interrupts, the disabling becomes effective after execution of the instruction.

When an interrupt enable bit is cleared to 0 by an instruction such as BCLR or MOV, and if an interrupt is generated during execution of the instruction, the interrupt concerned will still be enabled on completion of the instruction, and so interrupt exception handling for that interrupt will be executed on completion of the instruction. However, if there is an interrupt request of higher priority than that interrupt, interrupt exception handling will be executed for the higher-priority interrupt, and the lower-priority interrupt will be ignored.

The same also applies when an interrupt source flag is cleared to 0.

Figure 5.6 shows an example in which the TCIEV bit in TIER_0 of the TPU is cleared to 0.

The above conflict will not occur if an enable bit or interrupt source flag is cleared to 0 while the interrupt is masked.

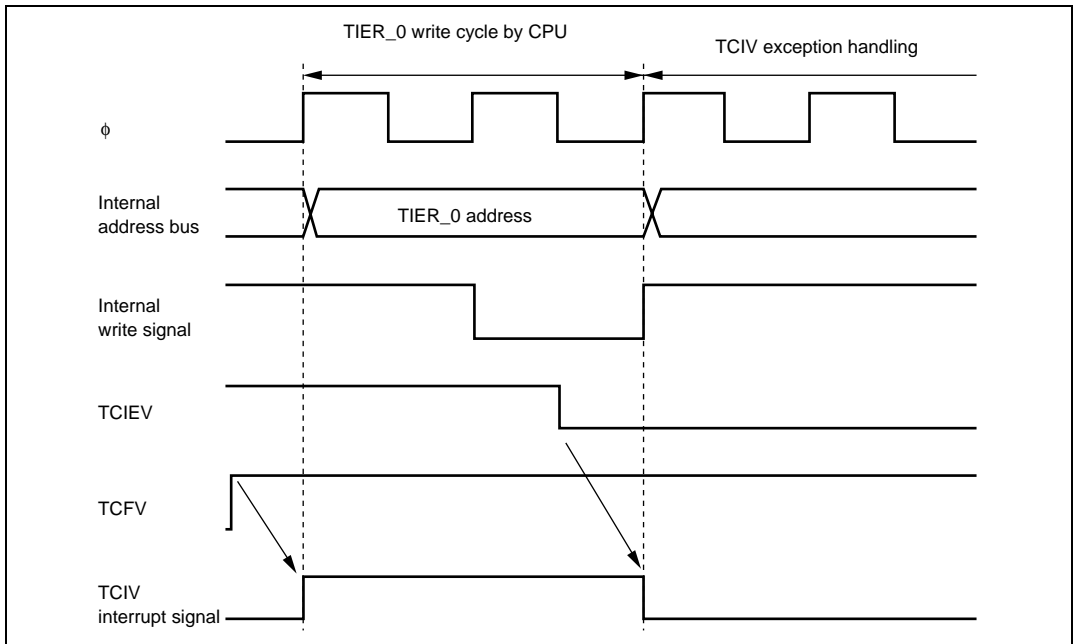

Figure 5.6 Conflict between Interrupt Generation and Disabling

5.7.2 Instructions that Disable Interrupts

The instructions that disable interrupts are LDC, ANDC, ORC, and XORC. After any of these instructions are executed, all interrupts including NMI are disabled and the next instruction is always executed. When the I bit is set by one of these instructions, the new value becomes valid two states after execution of the instruction ends.

5.7.3 When Interrupts Are Disabled

There are times when interrupt acceptance is disabled by the interrupt controller.

The interrupt controller disables interrupt acceptance for a 3-state period after the CPU has updated the mask level with an LDC, ANDC, ORC, or XORC instruction.

5.7.4 Interrupts during Execution of EEPMOV Instruction

Interrupt operation differs between the EEPMOV.B instruction and the EEPMOV.W instruction.

With the EEPMOV.B instruction, an interrupt request (including NMI) issued during the transfer is not accepted until the transfer is completed.

With the EEPMOV.W instruction, if an interrupt request is issued during the transfer, interrupt exception handling starts at a break in the transfer cycle. The PC value saved on the stack in this case is the address of the next instruction.

Therefore, if an interrupt is generated during execution of an EEPMOV.W instruction, the following coding should be used.

```
L1:   EEPMOV.W
      MOV.W   R4, R4
      BNE     L1
```

5.7.5 IRQ Interrupt

When operating by clock input, acceptance of input to an IRQ is synchronized with the clock. In software standby mode, the input is accepted asynchronously. For details on the input conditions, see section 23.3.2, Control Signal Timing.

Section 6 PC Break Controller (PBC)

The PC break controller (PBC) provides functions that simplify program debugging. Using these functions, it is easy to create a self-monitoring debugger, enabling programs to be debugged with the chip alone, without using an in-circuit emulator. A block diagram of the PC break controller is shown in figure 6.1.

6.1 Features

- Two break channels (A and B)
- 24-bit break address
 - Bit masking possible
- Four types of break compare conditions
 - Instruction fetch
 - Data read
 - Data write
 - Data read/write
- Bus master
 - Either CPU or CPU/DTC can be selected
- The timing of PC break exception handling after the occurrence of a break condition is as follows
 - Immediately before execution of the instruction fetched at the set address (instruction fetch)
 - Immediately after execution of the instruction that accesses data at the set address (data access)
- Module stop mode can be set

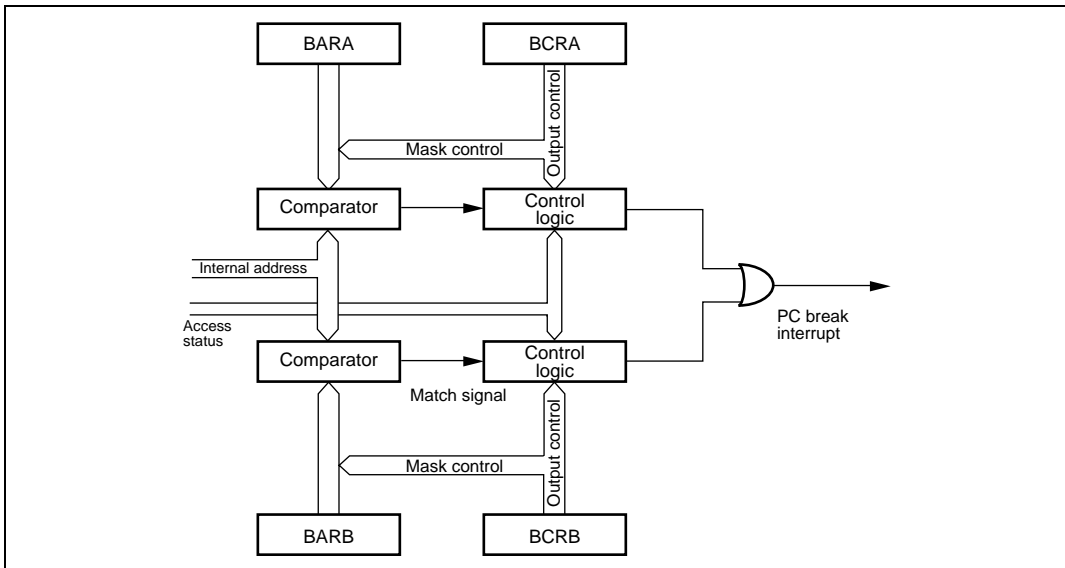

Figure 6.1 Block Diagram of PC Break Controller

6.2 Register Descriptions

The PC break controller has the following registers.

- Break address register A (BARA)
- Break address register B (BARB)
- Break control register A (BCRA)
- Break control register B (BCRB)

6.2.1 Break Address Register A (BARA)

BARA is a 32-bit readable/writable register that specifies the channel A break address.

Bit	Bit Name	Initial Value	R/W	Description
31 to 24	—	Undefined	—	Reserved These bits are read as an undefined value and cannot be modified.
23 to 0	BAA23 to BAA0	H'000000	R/W	These bits set the channel A PC break address.

6.2.2 Break Address Register B (BARB)

BARB is the channel B break address register. The bit configuration is the same as for BARA.

6.2.3 Break Control Register A (BCRA)

BCRA controls channel A PC breaks. BCRA also contains a condition match flag.

Bit	Bit Name	Initial Value	R/W	Description
7	CMFA	0	R/W	Condition Match Flag A [Setting condition] <ul style="list-style-type: none"> When a condition set for channel A is satisfied [Clearing condition] <ul style="list-style-type: none"> When 0 is written to CMFA after reading CMFA = 1
6	CDA	0	R/W	CPU Cycle/DTC Cycle Select A Selects the channel A break condition bus master. 0: CPU 1: CPU or DTC
5	BAMRA2	0	R/W	Break Address Mask Register A2 to A0 These bits specify which bits of the break address set in BARA are to be masked. 000: BAA23 to BAA0 (All bits are unmasked) 001: BAA23 to BAA1 (Lowest bit is masked) 010: BAA23 to BAA2 (Lower 2 bits are masked) 011: BAA23 to BAA3 (Lower 3 bits are masked) 100: BAA23 to BAA4 (Lower 4 bits are masked) 101: BAA23 to BAA8 (Lower 8 bits are masked) 110: BAA23 to BAA12 (Lower 12 bits are masked) 111: BAA23 to BAA16 (Lower 16 bits are masked)
4	BAMRA1	0	R/W	
3	BAMRA0	0	R/W	

Bit	Bit Name	Initial Value	R/W	Description
2	CSELA1	0	R/W	Break Condition Select A
1	CSELA0	0	R/W	Selects break condition of channel A. 00: Instruction fetch is used as break condition 01: Data read cycle is used as break condition 10: Data write cycle is used as break condition 11: Data read/write cycle is used as break condition
0	BIEA	0	R/W	Break Interrupt Enable A When this bit is 1, the PC break interrupt request of channel A is enabled.

6.2.4 Break Control Register B (BCRB)

BCRB is the channel B break control register. The bit configuration is the same as for BCRA.

6.3 Operation

The operation flow from break condition setting to PC break interrupt exception handling is shown in section 6.3.1, PC Break Interrupt Due to Instruction Fetch, and section 6.3.2, PC Break Interrupt Due to Data Access, taking the example of channel A.

6.3.1 PC Break Interrupt Due to Instruction Fetch

1. Set the break address in BARA.
For a PC break caused by an instruction fetch, set the address of the first instruction byte as the break address.
2. Set the break conditions in BCR.
Set bit 6 (CDA) to 0 to select the CPU because the bus master must be the CPU for a PC break caused by an instruction fetch. Set the address bits to be masked to bits 5 to 3 (BAMA2 to BAMA0). Set bits 2 and 1 (CSELA1 and CSELA0) to 00 to specify an instruction fetch as the break condition. Set bit 0 (BIEA) to 1 to enable break interrupts.
3. When the instruction at the set address is fetched, a PC break request is generated immediately before execution of the fetched instruction, and the condition match flag (CMFA) is set.
4. After priority determination by the interrupt controller, PC break interrupt exception handling is started.

6.3.2 PC Break Interrupt Due to Data Access

1. Set the break address in BARA.
For a PC break caused by a data access, set the target ROM, RAM, I/O, or external address space address as the break address. Stack operations and branch address reads are included in data accesses.
2. Set the break conditions in BCRA.
Select the bus master with bit 6 (CDA). Set the address bits to be masked to bits 5 to 3 (BAMA2 to BAMA0). Set bits 2 and 1 (CSELA1 and CSELA0) to 01, 10, or 11 to specify data access as the break condition. Set bit 0 (BIEA) to 1 to enable break interrupts.
3. After execution of the instruction that performs a data access on the set address, a PC break request is generated and the condition match flag (CMFA) is set.
4. After priority determination by the interrupt controller, PC break interrupt exception handling is started.

6.3.3 PC Break Operation at Consecutive Data Transfer

- When a PC break interrupt is generated at the transfer address of an EEPMOV.B instruction PC break exception handling is executed after all data transfers have been completed and the EEPMOV.B instruction has ended.
- When a PC break interrupt is generated at a DTC transfer address
PC break exception handling is executed after the DTC has completed the specified number of data transfers, or after data for which the DISEL bit is set to 1 has been transferred.

6.3.4 Operation in Transitions to Power-Down Modes

The operation when a PC break interrupt is set for an instruction fetch at the address after a SLEEP instruction is shown below.

- When the SLEEP instruction causes a transition from high-speed (medium-speed) mode to sleep mode:
After execution of the SLEEP instruction, a transition is not made to sleep mode, and PC break exception handling is executed. After execution of PC break exception handling, the instruction at the address after the SLEEP instruction is executed (figure 6.2 (A)).
- When the SLEEP instruction causes a transition to software standby mode:
After execution of the SLEEP instruction, a transition is made to software standby mode, and PC break exception handling is not executed. However, the CMFA or CMFB flag is set (figure 6.2 (B)).

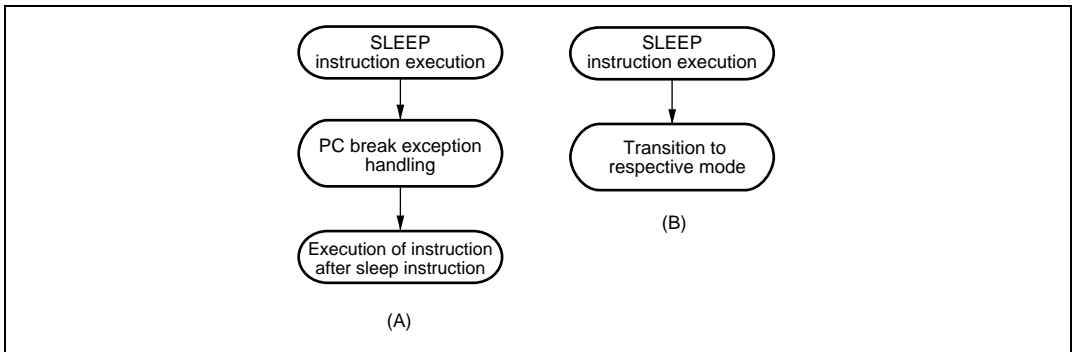

Figure 6.2 Operation in Power-Down Mode Transitions

6.3.5 When Instruction Execution Is Delayed by One State

While the break interrupt enable bit is set to 1, instruction execution is one state later than usual.

- For 1-word branch instructions (Bcc d:8, BSR, JSR, JMP, TRAPA, RTE, and RTS) in on-chip ROM or RAM.
- When break interrupt by instruction fetch is set, the set address indicates on-chip ROM or RAM space, and that address is used for data access, the instruction will be one state later than in normal operation.
- When break interrupt by instruction fetch is set and a break interrupt is generated, if the executing instruction immediately preceding the set instruction has one of the addressing modes shown below, and that address indicates on-chip ROM or RAM, the instruction will be one state later than in normal operation.

Addressing modes: @ERn, @(d:16,ERn), @(d:32,ERn), @-ERn/ERn+, @aa:8, @aa:24, @aa:32, @(d:8,PC), @(d:16,PC), @@aa:8

- When break interrupt by instruction fetch is set and a break interrupt is generated, if the executing instruction immediately preceding the set instruction is NOP or SLEEP, or has #xx,Rn as its addressing mode, and that instruction is located in on-chip ROM or RAM, the instruction will be one state later than in normal operation.

6.4 Usage Notes

6.4.1 Module Stop Mode Setting

PBC operation can be disabled or enabled using the module stop control register. The initial setting is for PBC operation to be halted. Register access is enabled by clearing module stop mode. For details, refer to section 21, Power-Down Modes.

6.4.2 PC Break Interrupts

The PC break interrupt is shared by channels A and B. The channel from which the request was issued must be determined by the interrupt handler.

6.4.3 CMFA and CMFB

The CMFA and CMFB flags are not automatically cleared to 0, so 0 must be written to CMFA or CMFB after first reading the flag while it is set to 1. If the flag is left set to 1, another interrupt will be requested after interrupt handling ends.

6.4.4 PC Break Interrupt when DTC Is Bus Master

A PC break interrupt generated when the DTC is the bus master is accepted after the bus mastership has been transferred to the CPU by the bus controller.

6.4.5 PC Break Set for Instruction Fetch at Address Following BSR, JSR, JMP, TRAPA, RTE, or RTS Instruction

Even if the instruction at the address following a BSR, JSR, JMP, TRAPA, RTE, or RTS instruction is fetched, it is not executed, and so a PC break interrupt is not generated by the instruction fetch at the next address.

6.4.6 I Bit Set by LDC, ANDC, ORC, or XORC Instruction

When the I bit is set by an LDC, ANDC, ORC, or XORC instruction, a PC break interrupt becomes valid two states after the end of the instruction execution. If a PC break interrupt is set for the instruction following one of these instructions, since interrupts, including NMI, are disabled for a 3-state period in the case of LDC, ANDC, ORC, and XOR, the next instruction is always executed. For details, see section 5, Interrupt Controller.

6.4.7 PC Break Set for Instruction Fetch at Address Following Bcc Instruction

A PC break interrupt is generated if the instruction at the next address is executed in accordance with the branch condition, and is not generated if the instruction at the next address is not executed.

6.4.8 PC Break Set for Instruction Fetch at Branch Destination Address of Bcc Instruction

A PC break interrupt is generated if the instruction at the branch destination is executed in accordance with the branch condition, and is not generated if the instruction at the branch destination is not executed.

Section 7 Bus Controller

The H8S/2600 CPU is driven by a system clock, denoted by the symbol ϕ .

The bus controller controls a memory cycle and a bus cycle. Different methods are used to access on-chip memory and on-chip support modules. The bus controller also has a bus arbitration function, and controls the operation of the internal bus masters: the CPU and data transfer controller (DTC).

7.1 Basic Timing

The period from one rising edge of ϕ to the next is referred to as a “state”. The memory cycle or bus cycle consists of one, two, three, or four states. Different methods are used to access on-chip memory and on-chip support modules.

7.1.1 On-Chip Memory Access Timing (ROM, RAM)

On-chip memory is accessed in one state. The data bus is 16 bits wide, permitting both byte and word transfer instruction. Figure 7.1 shows the on-chip memory access cycle.

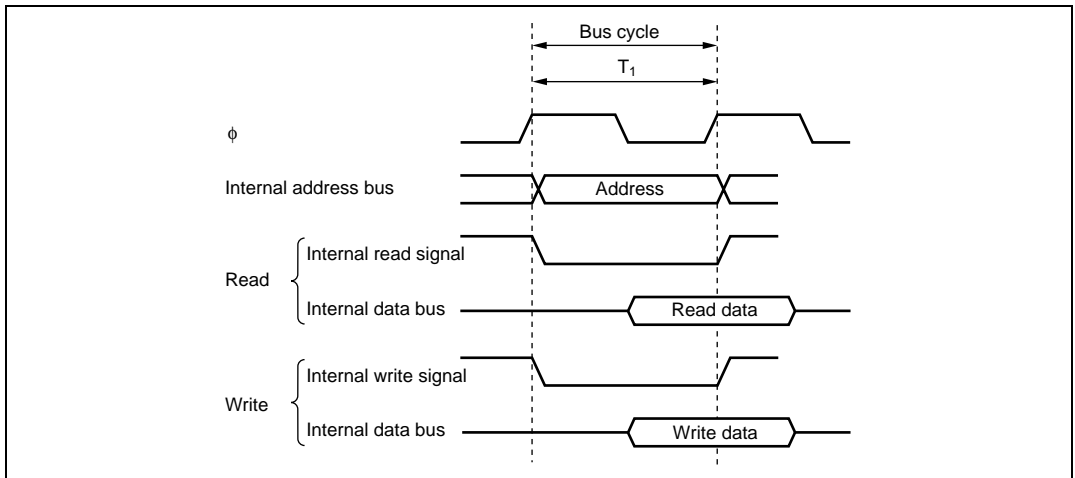

Figure 7.1 On-Chip Memory Access Cycle

7.1.2 On-Chip Support Module Access Timing

The on-chip support modules, except for the HCAN, SSU, and realtime input port data register, are accessed in two states. The data bus is either 8 bits or 16 bits wide, depending on the particular internal I/O register being accessed. For details, refer to section 22, List of Registers. Figure 7.2 shows access timing for the on-chip peripheral modules.

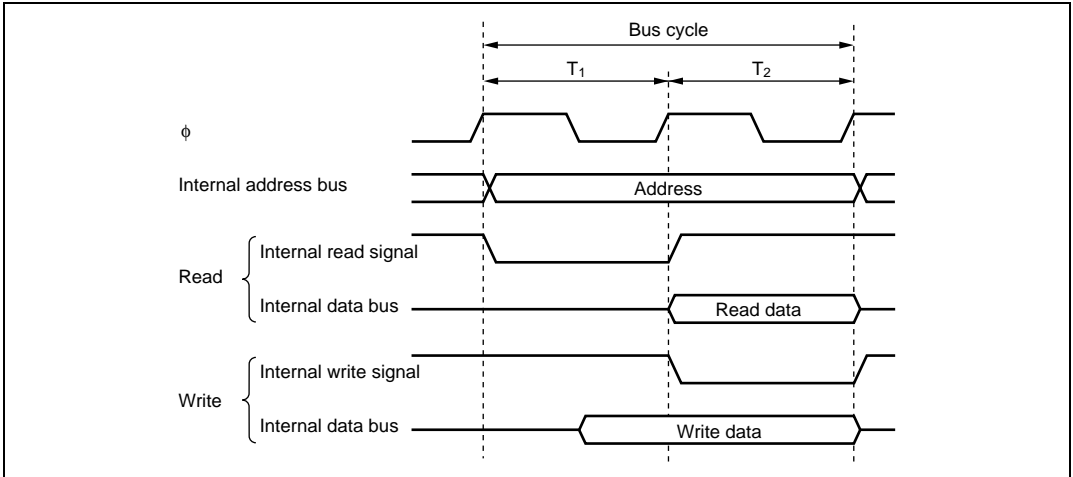

Figure 7.2 On-Chip Support Module Access Cycle

7.1.3 On-Chip HCAN Module Access Timing

On-chip HCAN module access is performed in four states. The data bus width is 16 bits. Wait states can be inserted by means of a wait request from the HCAN. On-chip HCAN module access timing is shown in figure 7.3.

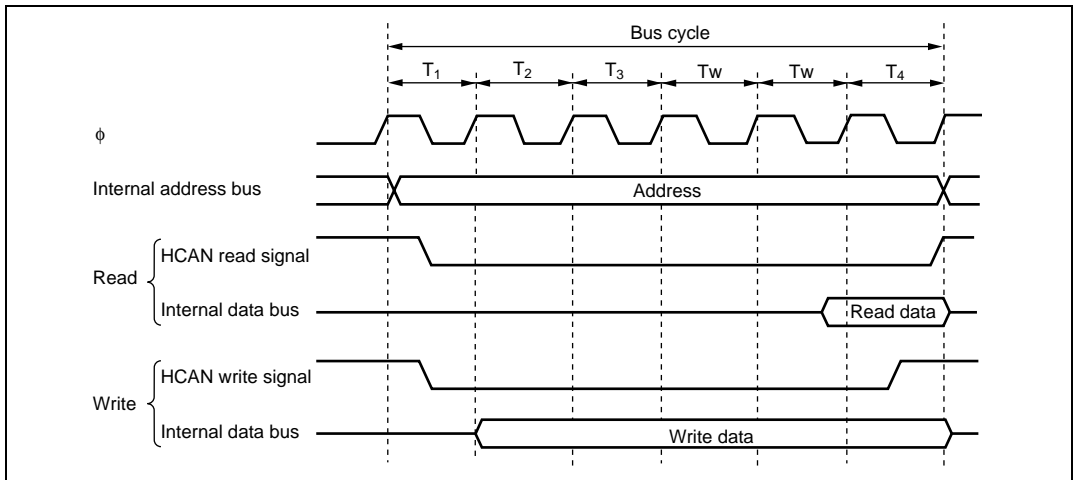

Figure 7.3 On-Chip HCAN Module Access Cycle (with Wait States)

7.1.4 On-Chip SSU Module and Realtime Input Port Data Register Access Timing

The on-chip SSU module or realtime input port data register is accessed in three states. At this time, a data bus width is 16 bits. Figure 7.4 shows the SSU module access timing.

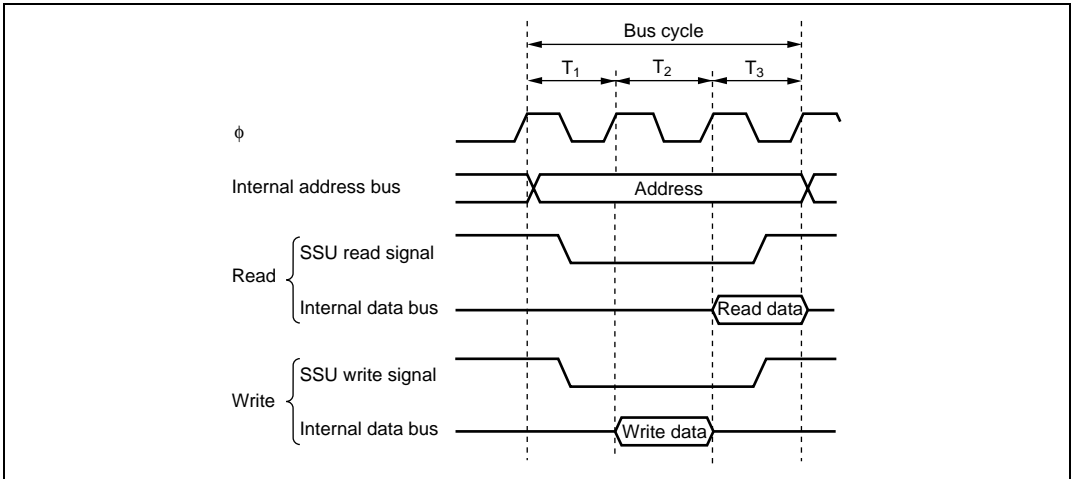

Figure 7.4 On-Chip SSU Module Access Cycle

7.2 Bus Arbitration

The Bus Controller has a bus arbiter that arbitrates bus master operations.

There are two bus masters, the CPU and DTC, which perform read/write operations when they control the bus.

7.2.1 Order of Priority of the Bus Masters

Each bus master requests the bus mastership by means of a bus request signal. The bus arbiter detects the bus masters' bus request signals, and if the bus mastership is requested, sends a bus request acknowledge signal to the bus master making the request. If there are bus requests from more than one bus master, the bus request acknowledge signal is sent to the one with the highest priority. When a bus master receives the bus request acknowledge signal, it takes possession of the bus until that signal is cancelled.

The order of priority of the bus mastership is as follows:

(High) DTC > CPU (Low)

7.2.2 Bus Transfer Timing

Even if a bus request is received from a bus master with a higher priority than that of the bus master that has acquired the bus mastership and is currently operating, the bus mastership is not necessarily transferred immediately. The CPU is the lowest-priority bus master, and if a bus request is received from the DTC, the bus arbiter transfers the bus mastership to the bus master that issued the request. The timing for transfer of the bus mastership is as follows:

- The bus mastership is transferred at a break between bus cycles.
However, if a bus cycle is executed in discrete operations, as in the case of a longword-size access, the bus mastership is not transferred between such operations. For details, refer to section 2.7, Bus Status in Instruction Execution in the H8S/2600 Series, H8S/2000 Series Programming Manual.
- If the CPU is in sleep mode, it transfers the bus mastership immediately.

The DTC can release the bus mastership after a vector read, a register information read (3 states), a single data transfer, or a register information write (3 states). It does not release the bus mastership during a register information read (3 states), a single data transfer, or a register information write (3 states).

Section 8 Data Transfer Controller (DTC)

This LSI includes a data transfer controller (DTC). The DTC can be activated by an interrupt or software, to transfer data.

Figure 8.1 shows a block diagram of the DTC.

The DTC's register information is stored in the on-chip RAM. When the DTC is used, the RAME bit in SYSCR must be set to 1. A 32-bit bus connects the DTC to the on-chip RAM (1 kbyte), enabling 32-bit/1-state reading and writing of the DTC register information.

8.1 Features

- Transfer is possible over any number of channels
- Three transfer modes
 - Normal, repeat, and block transfer modes are available
- One activation source can trigger a number of data transfers (chain transfer)
- The direct specification of 16-Mbyte address space is possible
- Activation by software is possible
- Transfer can be set in byte or word units
- A CPU interrupt can be requested for the interrupt that activated the DTC
- Module stop mode can be set

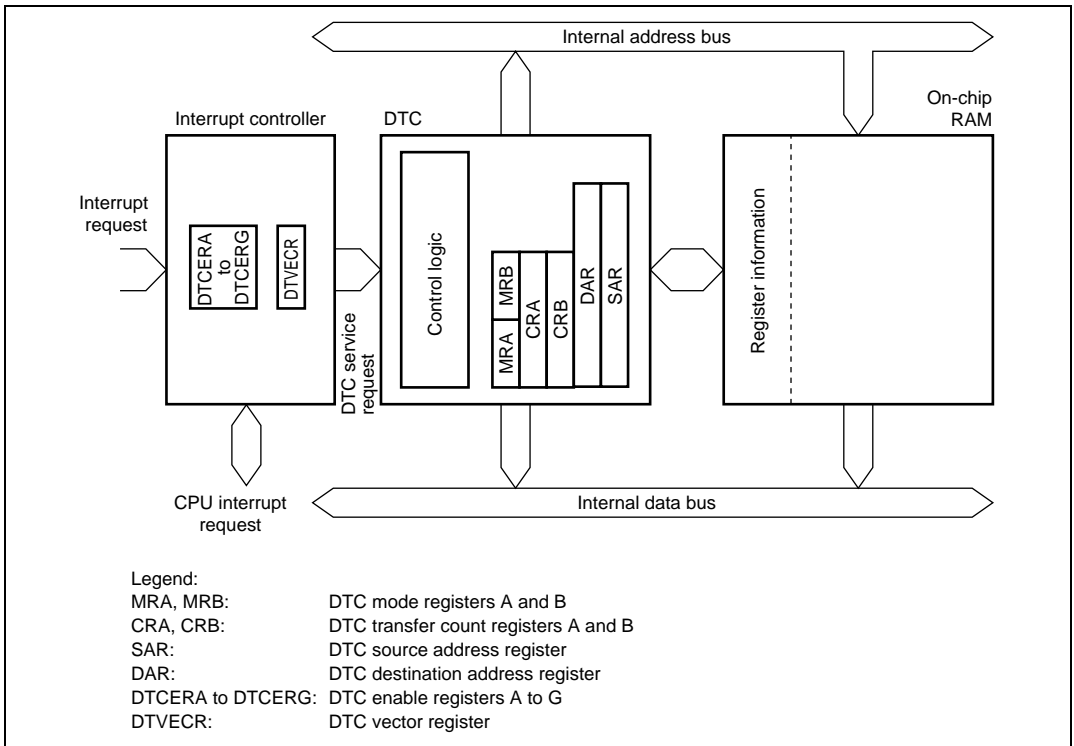

Figure 8.1 Block Diagram of DTC

8.2 Register Descriptions

The DTC has the following registers.

- DTC mode register A (MRA)
- DTC mode register B (MRB)
- DTC source address register (SAR)
- DTC destination address register (DAR)
- DTC transfer count register A (CRA)
- DTC transfer count register B (CRB)

These six registers cannot be directly accessed from the CPU.

When activated, the DTC reads a set of register information that is stored in on-chip RAM to the corresponding DTC registers and transfers data. After the data transfer, it writes a set of updated register information back to the RAM.

- DTC enable registers (DTCER)
- DTC vector register (DTVECR)

8.2.1 DTC Mode Register A (MRA)

MRA is an 8-bit register that selects the DTC operating mode.

Bit	Bit Name	Initial Value	R/W	Description
7	SM1	Undefined	—	Source Address Mode 1 and 0
6	SM0	Undefined	—	These bits specify an SAR operation after a data transfer. 0x: SAR is fixed 10: SAR is incremented after a transfer (by +1 when Sz = 0; by +2 when Sz = 1) 11: SAR is decremented after a transfer (by -1 when Sz = 0; by -2 when Sz = 1)
5	DM1	Undefined	—	Destination Address Mode 1 and 0
4	DM0	Undefined	—	These bits specify a DAR operation after a data transfer. 0x: DAR is fixed 10: DAR is incremented after a transfer (by +1 when Sz = 0; by +2 when Sz = 1) 11: DAR is decremented after a transfer (by -1 when Sz = 0; by -2 when Sz = 1)
3	MD1	Undefined	—	DTC Mode
2	MD0	Undefined	—	These bits specify the DTC transfer mode. 00: Normal mode 01: Repeat mode 10: Block transfer mode 11: Setting prohibited
1	DTS	Undefined	—	DTC Transfer Mode Select Specifies whether the source side or the destination side is set to be a repeat area or block area, in repeat mode or block transfer mode. 0: Destination side is repeat area or block area 1: Source side is repeat area or block area
0	Sz	Undefined	—	DTC Data Transfer Size Specifies the size of data to be transferred. 0: Byte-size transfer 1: Word-size transfer

Legend:

x: Don't care

8.2.2 DTC Mode Register B (MRB)

MRB is an 8-bit register that selects the DTC operating mode.

Bit	Bit Name	Initial Value	R/W	Description
7	CHNE	Undefined	—	DTC Chain Transfer Enable When this bit is set to 1, a chain transfer will be performed. For details, refer to 8.5.4, Chain Transfer. In data transfer with CHNE set to 1, determination of the end of the specified number of transfers, clearing of the interrupt source flag, and clearing of DTCER, are not performed.
6	DISEL	Undefined	—	DTC Interrupt Select When this bit is set to 1, a CPU interrupt request is generated every time after the end of a data transfer. When this bit is set to 0, a CPU interrupt request is generated at the time when the specified number of data transfer ends.
5 to 0	—	Undefined	—	Reserved These bits have no effect on DTC operation. Only 0 should be written to these bits.

8.2.3 DTC Source Address Register (SAR)

SAR is a 24-bit register that designates the source address of data to be transferred by the DTC. For word-size transfer, specify an even source address.

8.2.4 DTC Destination Address Register (DAR)

DAR is a 24-bit register that designates the destination address of data to be transferred by the DTC. For word-size transfer, specify an even destination address.

8.2.5 DTC Transfer Count Register A (CRA)

CRA is a 16-bit register that designates the number of times data is to be transferred by the DTC.

In normal mode, the entire CRA functions as a 16-bit transfer counter (1 to 65,536). It is decremented by 1 every time data is transferred, and transfer ends when the count reaches H'0000.

In repeat mode or block transfer mode, the CRA is divided into two parts; the upper 8 bits (CRAH) and the lower 8 bits (CRAL). CRAH holds the number of transfers while CRAL functions as an 8-bit transfer counter (1 to 256). CRAL is decremented by 1 every time data is transferred, and the contents of CRAH are sent when the count reaches H'00.

8.2.6 DTC Transfer Count Register B (CRB)

CRB is a 16-bit register that designates the number of times data is to be transferred by the DTC in block transfer mode. It functions as a 16-bit transfer counter (1 to 65,536) that is decremented by 1 every time data is transferred, and transfer ends when the count reaches H'0000.

8.2.7 DTC Enable Registers (DTCER)

DTCER is comprised of seven registers; DTCERA to DTCERG, and is a register that specifies DTC activation interrupt sources. The correspondence between interrupt sources and DTCE bits is shown in table 8.1. For DTCE bit setting, use bit manipulation instructions such as BSET and BCLR for reading and writing. If all interrupts are masked, multiple activation sources can be set at one time (only at the initial setting) by writing data after executing a dummy read on the relevant register.

Bit	Bit Name	Initial Value	R/W	Description
7	DTCE7	0	R/W	DTC Activation Enable
6	DTCE6	0	R/W	Setting these bits to 1 specifies a relevant interrupt source as a DTC activation source.
5	DTCE5	0	R/W	
4	DTCE4	0	R/W	[Clearing conditions]
3	DTCE3	0	R/W	
2	DTCE2	0	R/W	<ul style="list-style-type: none"> When the DISEL bit in MRB is 1 and the data transfer has ended
1	DTCE1	0	R/W	
0	DTCE0	0	R/W	<ul style="list-style-type: none"> When the specified number of transfers have ended <p>These bits are not cleared when the DISEL bit is 0 and the specified number of transfers have not been completed.</p>

8.2.8 DTC Vector Register (DTVECR)

DTVECR is an 8-bit readable/writable register that enables or disables DTC activation by software, and sets a vector number for the software activation interrupt.

Bit	Bit Name	Initial Value	R/W	Description
7	SWDTE	0	R/W	<p>DTC Software Activation Enable</p> <p>Setting this bit to 1 activates DTC. Only 1 can be written to this bit.</p> <p>[Clearing conditions]</p> <ul style="list-style-type: none"> • When the DISEL bit is 0 and the specified number of transfers have not ended • When 0 is written to the DISEL bit after a software-activated data transfer end interrupt (SWDTEND) request has been sent to the CPU. <p>When the DISEL bit is 1 and data transfer has ended or when the specified number of transfers have ended, this bit will not be cleared.</p>
6	DTVEC6	0	R/W	DTC Software Activation Vectors 6 to 0
5	DTVEC5	0	R/W	These bits specify a vector number for DTC software activation.
4	DTVEC4	0	R/W	
3	DTVEC3	0	R/W	The vector address is expressed as H'0400 + (vector number × 2). For example, when DTVEC6 to DTVEC0 = H'10, the vector address is H'0420. When the bit SWDTE is 0, these bits can be written.
2	DTVEC2	0	R/W	
1	DTVEC1	0	R/W	
0	DTVEC0	0	R/W	

8.3 Activation Sources

The DTC operates when activated by an interrupt or by a write to DTVECR by software. An interrupt request can be directed to the CPU or DTC, as designated by the corresponding DTCER bit. At the end of a data transfer (or the last consecutive transfer in the case of chain transfer), the activation source or corresponding DTCER bit is cleared. The activation source flag, in the case of RXI_0, for example, is the RDRF flag of SCI_0.

When an interrupt has been designated a DTC activation source, the existing CPU mask level and interrupt controller priorities have no effect. If there is more than one activation source at the same time, the DTC operates in accordance with the default priorities.

Figure 8.2 shows a block diagram of DTC activation source control. For details, see section 5, Interrupt Controller.

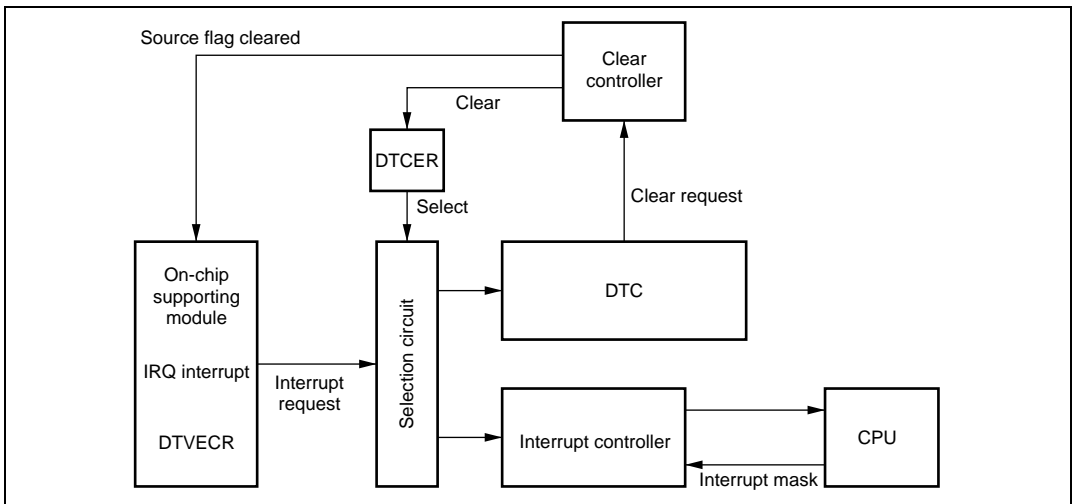

Figure 8.2 Block Diagram of DTC Activation Source Control

8.4 Location of Register Information and DTC Vector Table

Locate the register information in the on-chip RAM (addresses: H'FFEB0 to H'FFEFBF). Register information should be located at an address that is a multiple of four within the range. Locating the register information in address space is shown in figure 8.3. Locate the MRA, SAR, MRB, DAR, CRA, and CRB registers, in that order, from the start address of the register information.

In the case of chain transfer, register information should be located in consecutive areas and the register information start address should be located at the vector address corresponding to the interrupt source as shown in figure 8.3. The DTC reads the start address of the register information from the vector address set for each activation source, and then reads the register information from that start address.

When the DTC is activated by software, the vector address is obtained from: $H'0400 + (DTVECR[6:0] \times 2)$. For example, if DTVECR is H'10, the vector address is H'0420. The configuration of the vector address is the same in both normal and advanced modes, a 2-byte unit being used in both cases. These two bytes specify the lower bits of the register information start address.

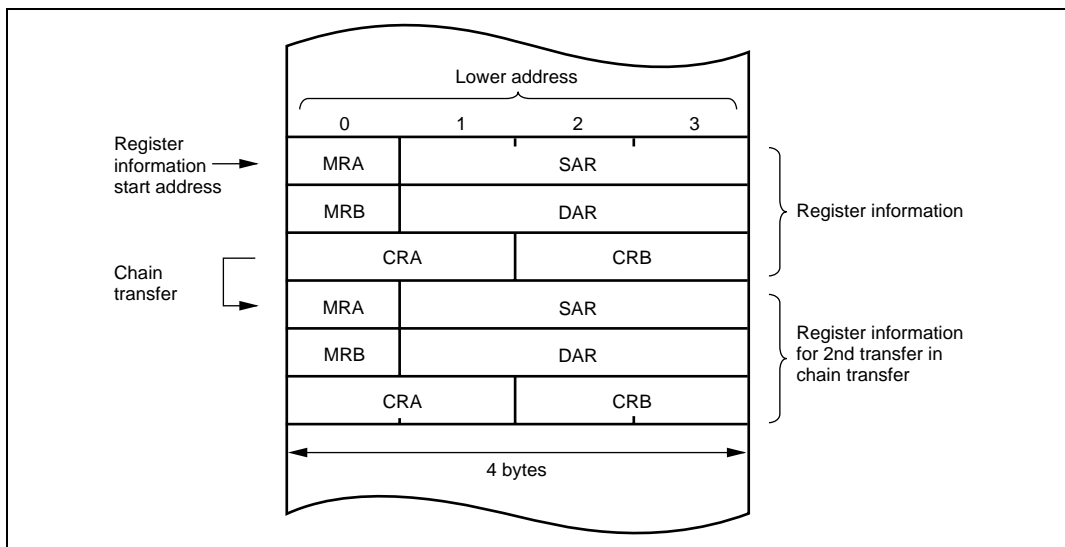

Figure 8.3 Location of DTC Register Information in Address Space

Table 8.1 Interrupt Sources, DTC Vector Addresses, and Corresponding DTCEs

Interrupt Source	Origin of Interrupt Source	Vector Number	DTC Vector Address	DTCE*	Priority
Software	Write to DTVECR	DTVECR	H'0400 + (vector number × 2)	—	High
External pin	IRQ0	16	H'0420	DTCEA7	↑
	IRQ1	17	H'0422	DTCEA6	
	IRQ2	18	H'0424	DTCEA5	
	IRQ3	19	H'0426	DTCEA4	
	IRQ4	20	H'0428	DTCEA3	
	IRQ5	21	H'042A	DTCEA2	
	Reserved for system use	22	H'042C	DTCEA1	
		23	H'042E	DTCEA0	
A/D counter	ADI (A/D conversion end)	28	H'0438	DTCEB6	
TPU channel 0	TGIA_0	32	H'0440	DTCEB5	
	TGIB_0	33	H'0442	DTCEB4	
	TGIC_0	34	H'0444	DTCEB3	
	TGID_0	35	H'0446	DTCEB2	
TPU channel 1	TGIA_1	40	H'0450	DTCEB1	
	TGIB_1	41	H'0452	DTCEB0	
TPU channel 2	TGIA_2	44	H'0458	DTCEC7	
	TGIB_2	45	H'045A	DTCEC6	
TPU channel 3	TGIA_3	48	H'0460	DTCEC5	
	TGIB_3	49	H'0462	DTCEC4	
	TGIC_3	50	H'0464	DTCEC3	
	TGID_3	51	H'0466	DTCEC2	
TPU channel 4	TGIA_4	56	H'0470	DTCEC1	
	TGIB_4	57	H'0472	DTCEC0	
TPU channel 5	TGIA_5	60	H'0478	DTCED5	
	TGIB_5	61	H'047A	DTCED4	Low

Interrupt Source	Origin of Interrupt Source	Vector Number	DTC Vector Address	DTCE*	Priority
8-bit timer channel 0	CMIA_1	64	H'0480	DTCED3	High ↑ Low
		65	H'0482	DTCED2	
8-bit timer channel 1	CMIB_1	68	H'0488	DTCED1	
		69	H'048A	DTCED0	
Reserved	Reserved	72	H'0490	DTCEE7	
		73	H'0492	DTCEE6	
		74	H'0494	DTCEE5	
		75	H'0496	DTCEE4	
SCI channel 0	RXI_0	81	H'04A2	DTCEE3	
	TXI_0	82	H'04A4	DTCEE2	
SCI channel 2	RXI_2	89	H'04B2	DTCEF7	
	TXI_2	90	H'04B4	DTCEF6	
8-bit timer channel 2	CMIA_2	92	H'04B8	DTCEF5	
	CMIB_2	93	H'04BA	DTCEF4	
8-bit timer channel 3	CMIA_3	96	H'04C0	DTCEF3	
	CMIB3	97	H'04C2	DTCEF2	
HCAN	Reserved for system use	104	H'04D0	DTCEG7	
	RM0	105	H'04D2	DTCEG6	
	Reserved for system use	106	H'04D4	DTCEG5	
	Reserved for system use	107	H'04D6	DTCEG4	
SSU channel 0	SSRx_i0	109	H'04DA	DTCEG2	
	SSTx_i0	110	H'04DC	DTCEG1	Low

Note: * DTCE bits with no corresponding interrupt are reserved, and the write value should always be 0.

8.5 Operation

Register information is stored in on-chip RAM. When activated, the DTC reads register information in on-chip RAM and transfers data. After the data transfer, the DTC writes updated register information back to the on-chip RAM.

The pre-storage of register information in the on-chip RAM makes it possible to transfer data over any required number of channels. The transfer mode can be specified as normal, repeat, and block transfer mode. Setting the CHNE bit in MRB to 1 makes it possible to perform a number of transfers with a single activation source (chain transfer).

The 24-bit SAR designates the DTC transfer source address, and the 24-bit DAR designates the transfer destination address. After each transfer, SAR and DAR are independently incremented, decremented, or left fixed depending on its register information.

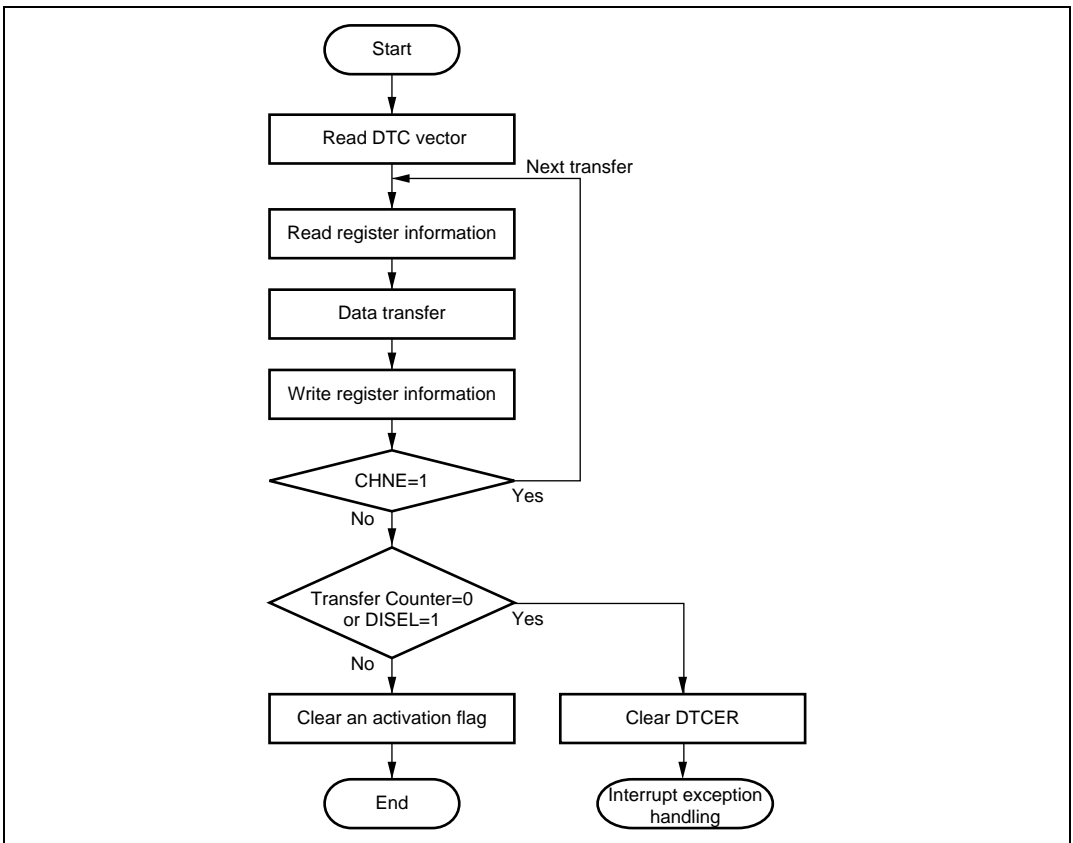

Figure 8.4 Flowchart of DTC Operation

8.5.1 Normal Mode

In normal mode, one operation transfers one byte or one word of data.

Table 8.2 lists the register information in normal mode.

From 1 to 65,536 transfers can be specified. Once the specified number of transfers have been completed, a CPU interrupt can be requested.

Table 8.2 Register Information in Normal Mode

Name	Abbreviation	Function
DTC source address register	SAR	Designates source address
DTC destination address register	DAR	Designates destination address
DTC transfer count register A	CRA	Designates transfer count
DTC transfer count register B	CRB	Not used

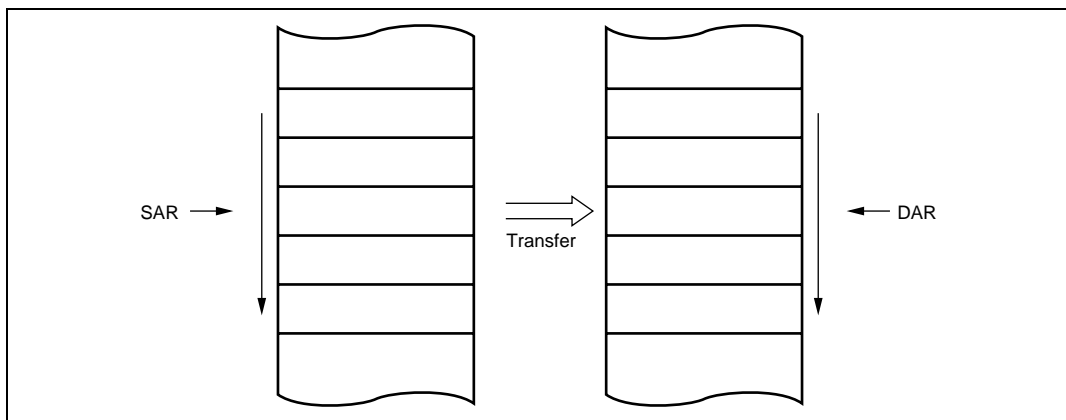

Figure 8.5 Memory Mapping in Normal Mode

8.5.2 Repeat Mode

In repeat mode, one operation transfers one byte or one word of data. Table 8.3 lists the register information in repeat mode.

From 1 to 256 transfers can be specified. Once the specified number of transfers have ended, the initial state of the transfer counter and the address register specified as the repeat area is restored, and transfer is repeated. In repeat mode the transfer counter value does not reach H'00, and therefore CPU interrupts cannot be requested when DISEL = 0.

Table 8.3 Register Information in Repeat Mode

Name	Abbreviation	Function
DTC source address register	SAR	Designates source address
DTC destination address register	DAR	Designates destination address
DTC transfer count register AH	CRAH	Holds number of transfers
DTC transfer count register AL	CRAL	Designates transfer count
DTC transfer count register B	CRB	Not used

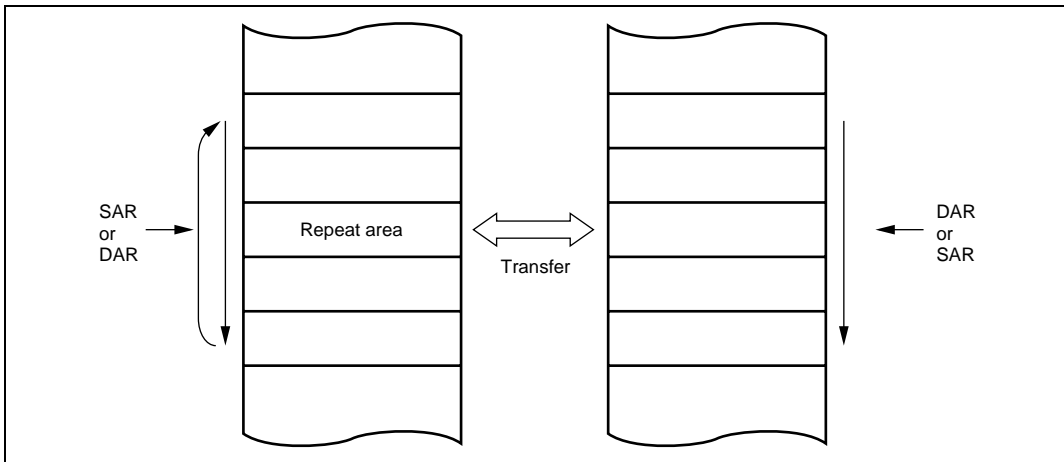

Figure 8.6 Memory Mapping in Repeat Mode

8.5.3 Block Transfer Mode

In block transfer mode, one operation transfers one block of data. Either the transfer source or the transfer destination is designated as a block area. Table 8.4 lists the register information in block transfer mode.

The block size can be between 1 and 256. When the transfer of one block ends, the initial state of the block size counter and the address register specified as the block area is restored. The other address register is then incremented, decremented, or left fixed.

From 1 to 65,536 transfers can be specified. Once the specified number of transfers have been completed, a CPU interrupt is requested.

Table 8.4 Register Information in Block Transfer Mode

Name	Abbreviation	Function
DTC source address register	SAR	Designates source address
DTC destination address register	DAR	Designates destination address
DTC transfer count register AH	CRAH	Holds block size
DTC transfer count register AL	CRAL	Designates block size count
DTC transfer count register B	CRB	Transfer count

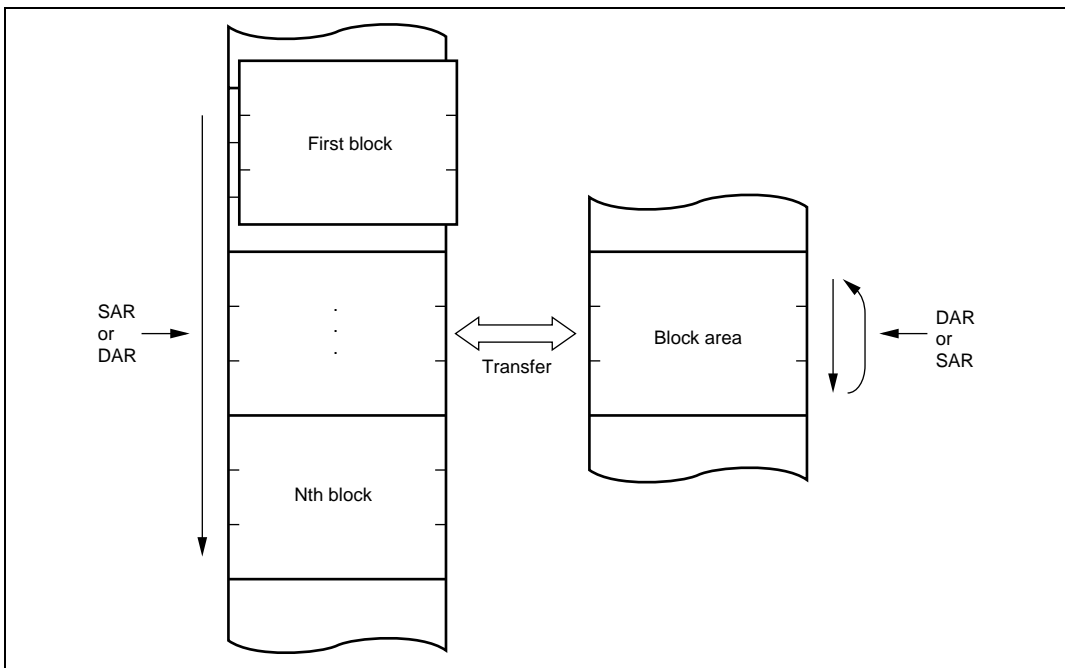

Figure 8.7 Memory Mapping in Block Transfer Mode

8.5.4 Chain Transfer

Setting the CHNE bit in MRB to 1 enables a number of data transfers to be performed consecutively in response to a single transfer request. SAR, DAR, CRA, CRB, MRA, and MRB, which define data transfers, can be set independently.

Figure 8.8 shows the outline of the chain transfer operation.

When activated, the DTC reads the register information start address stored at the vector address corresponding to the activation source, and then reads the first register information at that start address. After data transfer ends, the CHNE bit will be tested. When it has been set to 1, DTC reads the next register information located in a consecutive area and performs the data transfer. These sequences are repeated until the CHNE bit is cleared to 0.

In the case of transfer with CHNE set to 1, an interrupt request to the CPU is not generated at the end of the specified number of transfers or by setting of the DISEL bit to 1, and the interrupt source flag for the activation source is not affected.

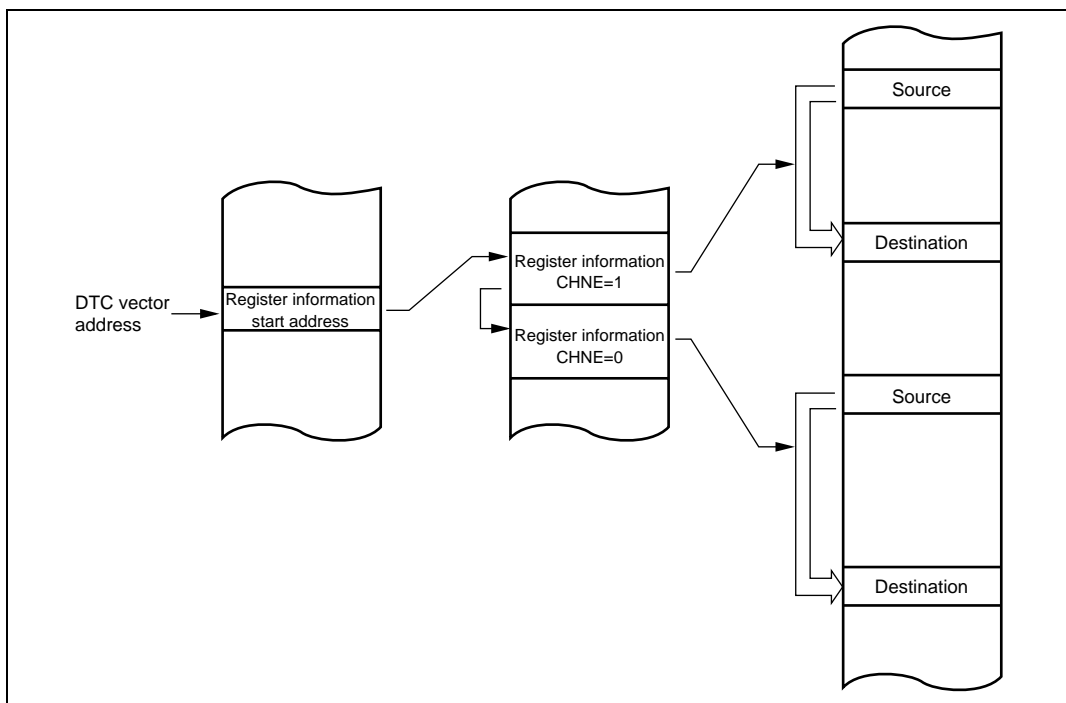

Figure 8.8 Chain Transfer Operation

8.5.5 Interrupts

An interrupt request is issued to the CPU when the DTC has completed the specified number of data transfers, or a data transfer for which the DISEL bit was set to 1. In the case of interrupt activation, the interrupt set as the activation source is generated. These interrupts to the CPU are subject to CPU mask level and interrupt controller priority level control.

In the case of software activation, a software-activated data transfer end interrupt (SWDTEND) is generated.

When the DISEL bit is 1 and one data transfer has been completed, or the specified number of transfers have been completed, after data transfer ends the SWDTE bit is held at 1 and an SWDTEND interrupt is generated. The interrupt handling routine will then clear the SWDTE bit to 0.

When the DTC is activated by software, an SWDTEND interrupt is not generated during a data transfer wait or during data transfer even if the SWDTE bit is set to 1.

8.5.6 Operation Timing

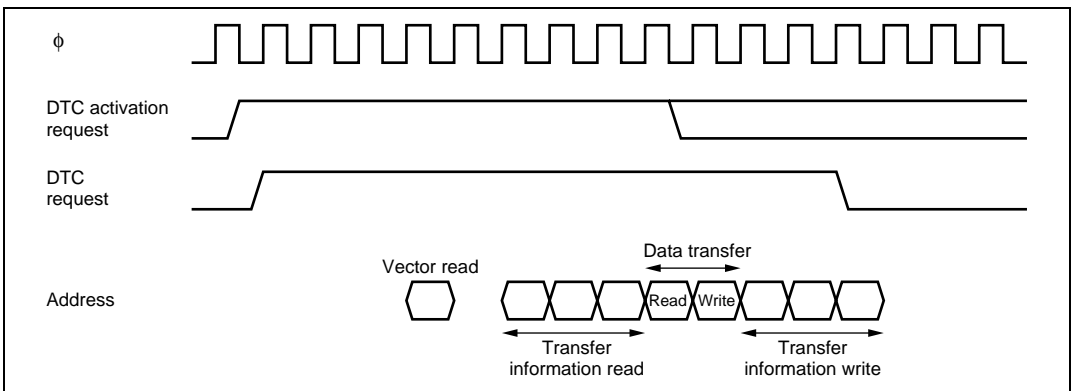

Figure 8.9 DTC Operation Timing (Example in Normal Mode or Repeat Mode)

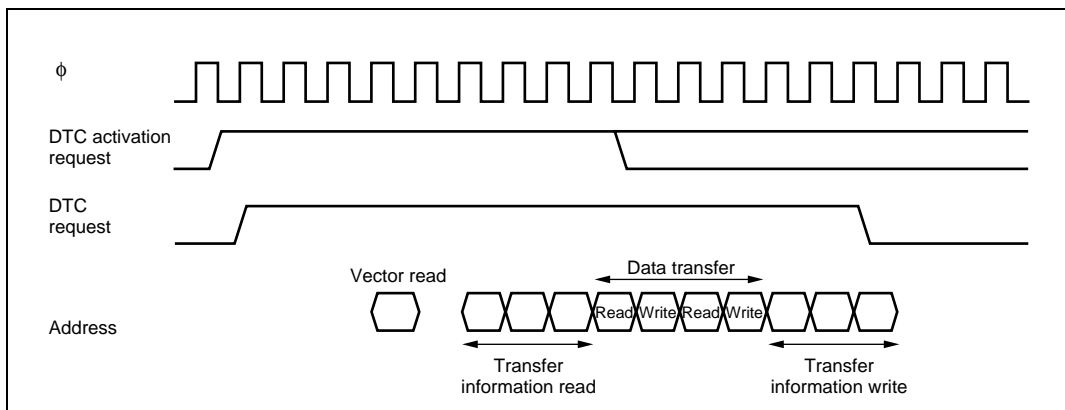

Figure 8.10 DTC Operation Timing (Example of Block Transfer Mode, with Block Size of 2)

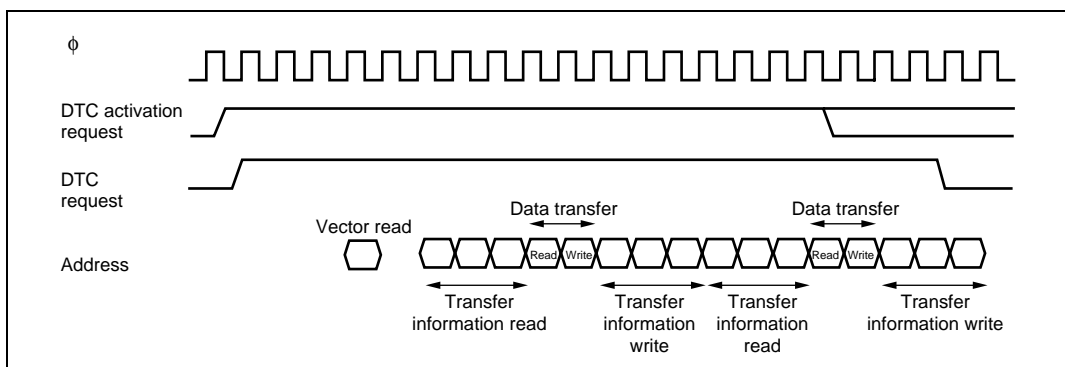

Figure 8.11 DTC Operation Timing (Example of Chain Transfer)

8.5.7 Number of DTC Execution States

Table 8.5 lists execution status for a single DTC data transfer, and table 8.6 shows the number of states required for each execution status.

Table 8.5 DTC Execution Status

Mode	Vector Read	Register Information		Data Read	Data Write	Internal Operations
	I	Read/Write	J	K	L	M
Normal	1	6		1	1	3
Repeat	1	6		1	1	3
Block transfer	1	6		N	N	3

Legend:

N: Block size (initial setting of CRAH and CRAL)

Table 8.6 Number of States Required for Each Execution Status

Object to be Accessed			On-Chip RAM	On-Chip ROM	On-Chip I/O Registers		External Devices*			
			32	16	8	16	8		16	
Access states			1	1	2	2	2	3	2	3
Execution status	Vector read	S _I	—	1	—	—	4	6+2m	2	3+m
	Register information read/write	S _J	1	—	—	—	—	—	—	—
	Byte data read	S _K	1	1	2	2	2	3+m	2	3+m
	Word data read	S _K	1	1	4	2	4	6+2m	2	3+m
	Byte data write	S _L	1	1	2	2	2	3+m	2	3+m
	Word data write	S _L	1	1	4	2	4	6+2m	2	3+m
	Internal operation	S _M	1							

Note: * Not available in this LSI.

The number of execution states is calculated from using the formula below. Note that Σ is the sum of all transfers activated by one activation source (the number in which the CHNE bit is set to 1, plus 1).

$$\text{Number of execution states} = I \cdot (1 + S_I) + \Sigma (J \cdot S_J + K \cdot S_K + L \cdot S_L) + M \cdot S_M$$

For example, when the DTC vector address table is located in the on-chip ROM, normal mode is set, and data is transferred from on-chip ROM to an internal I/O register, then the time required for the DTC operation is 13 states. The time from activation to the end of the data write is 10 states.

8.6 Procedures for Using DTC

8.6.1 Activation by Interrupt

The procedure for using the DTC with interrupt activation is as follows:

1. Set the MRA, MRB, SAR, DAR, CRA, and CRB register information in on-chip RAM.
2. Set the start address of the register information in the DTC vector address.
3. Set the corresponding bit in DTCER to 1.
4. Set the enable bits for the interrupt sources to be used as the activation sources to 1. The DTC is activated when an interrupt used as an activation source is generated.
5. After one data transfer has been completed, or after the specified number of data transfers have been completed, the DTCE bit is cleared to 0 and a CPU interrupt is requested. If the DTC is to continue transferring data, set the DTCE bit to 1.

8.6.2 Activation by Software

The procedure for using the DTC with software activation is as follows:

1. Set the MRA, MRB, SAR, DAR, CRA, and CRB register information in on-chip RAM.
2. Set the start address of the register information in the DTC vector address.
3. Check that the SWDTE bit is 0.
4. Write 1 to SWDTE bit and the vector number to DTVECR.
5. Check the vector number written to DTVECR.
6. After one data transfer has been completed, if the DISEL bit is 0 and a CPU interrupt is not requested, the SWDTE bit is cleared to 0. If the DTC is to continue transferring data, set the SWDTE bit to 1. When the DISEL bit is 1, or after the specified number of data transfers have been completed, the SWDTE bit is held at 1 and a CPU interrupt is requested.

8.7 Examples of Use of the DTC

8.7.1 Normal Mode

An example is shown in which the DTC is used to receive 128 bytes of data via the SCI.

1. Set MRA to a fixed source address ($SM1 = SM0 = 0$), incrementing destination address ($DM1 = 1, DM0 = 0$), normal mode ($MD1 = MD0 = 0$), and byte size ($Sz = 0$). The DTS bit can have any value. Set MRB for one data transfer by one interrupt ($CHNE = 0, DISEL = 0$). Set the SCI RDR address in SAR, the start address of the RAM area where data will be received in DAR, and 128 (H'0080) in CRA. CRB can be set to any value.
2. Set the start address of the register information at the DTC vector address.
3. Set the corresponding bit in DTCER to 1.
4. Set the SCI to the appropriate receive mode. Set the RIE bit in SCR to 1 to enable the reception complete (RXI) interrupt. Since the generation of a receive error during the SCI reception operation will disable subsequent reception, the CPU should be enabled to accept receive error interrupts.
5. Each time the reception of one byte of data has been completed on the SCI, the RDRF flag in SSR is set to 1, an RXI interrupt is generated, and the DTC is activated. The receive data is transferred from RDR to RAM by the DTC. DAR is incremented and CRA is decremented. The RDRF flag is automatically cleared to 0.
6. When CRA becomes 0 after the 128 data transfers have been completed, the RDRF flag is held at 1, the DTCE bit is cleared to 0, and an RXI interrupt request is sent to the CPU. The interrupt handling routine will perform wrap-up processing.

8.7.2 Chain Transfer

An example of DTC chain transfer is shown in which pulse output is performed using the PPG. Chain transfer can be used to perform pulse output data transfer and PPG output trigger cycle updating. Repeat mode transfer to the PPG's NDR is performed in the first half of the chain transfer, and normal mode transfer to the TPU's TGR in the second half. This is because clearing of the activation source and interrupt generation at the end of the specified number of transfers are restricted to the second half of the chain transfer (transfer when CHNE = 0).

1. Perform settings for transfer to the PPG's NDR. Set MRA to incrementing source address (SM1 = 1, SM0 = 0), a fixed destination address (DM1 = DM0 = 0), repeat mode (MD1 = 0, MD0 = 1), and word size (Sz = 1). Set the source side as a repeat area (DTS = 1). Set MRB to chain mode (CHNE = 1, DISEL = 0). Set the data table start address in SAR, the NDRH address in DAR, and the data table size in CRAH and CRAL. CRB can be set to any value.
2. Perform settings for transfer to the TPU's TGR. Set MRA to incrementing source address (SM1 = 1, SM0 = 0), a fixed destination address (DM1 = DM0 = 0), normal mode (MD1 = MD0 = 0), and word size (Sz = 1). Set the data table start address in SAR, the TGRA address in DAR, and the data table size in CRA. CRB can be set to any value.
3. Locate the TPU transfer register information consecutively after the NDR transfer register information.
4. Set the start address of the NDR transfer register information to the DTC vector address.
5. Set the bit corresponding to TGIA in DTCE to 1.
6. Set TGRA as an output compare register (output disabled) with TIOR, and enable the TGIA interrupt with TIER.
7. Set the initial output value in PODR, and the next output value in NDR. Set bits in DDR and NDER for which output is to be performed to 1. Using PCR, select the TPU compare match to be used as the output trigger.
8. Set the CST bit in TSTR to 1, and start the TCNT count operation.
9. Each time a TGRA compare match occurs, the next output value is transferred to NDR and the set value of the next output trigger period is transferred to TGRA. The activation source TGFA flag is cleared.
10. When the specified number of transfers are completed (the TPU transfer CRA value is 0), the TGFA flag is held at 1, the DTCE bit is cleared to 0, and a TGIA interrupt request is sent to the CPU. Termination processing should be performed in the interrupt handling routine.

8.7.3 Software Activation

An example is shown in which the DTC is used to transfer a block of 128 bytes of data by means of software activation. The transfer source address is H'1000 and the destination address is H'2000. The vector number is H'60, so the vector address is H'04C0.

1. Set MRA to incrementing source address (SM1 = 1, SM0 = 0), incrementing destination address (DM1 = 1, DM0 = 0), block transfer mode (MD1 = 1, MD0 = 0), and byte size (Sz = 0). The DTS bit can have any value. Set MRB for one block transfer by one interrupt (CHNE = 0). Set the transfer source address (H'1000) in SAR, the destination address (H'2000) in DAR, and 128 (H'8080) in CRA. Set 1 (H'0001) in CRB.
2. Set the start address of the register information at the DTC vector address (H'04C0).
3. Check that the SWDTE bit in DTVECR is 0. Check that there is currently no transfer activated by software.
4. Write 1 to the SWDTE bit and the vector number (H'60) to DTVECR. The write data is H'E0.
5. Read DTVECR again and check that it is set to the vector number (H'60). If it is not, this indicates that the write failed. This is presumably because an interrupt occurred between steps 3 and 4 and led to a different software activation. To activate this transfer, go back to step 3.
6. If the write was successful, the DTC is activated and a block of 128 bytes of data is transferred.
7. After the transfer, an SWDTEND interrupt occurs. The interrupt handling routine should clear the SWDTE bit to 0 and perform other wrap-up processing.

8.8 Usage Notes

8.8.1 Module Stop Mode Setting

DTC operation can be disabled or enabled using the module stop control register. The initial setting is for DTC operation to be enabled. Register access is disabled by setting module stop mode. Note that module stop mode cannot be set during DTC being activated. For details, refer to section 21, Power-Down Modes.

8.8.2 On-Chip RAM

The MRA, MRB, SAR, DAR, CRA, and CRB registers are all located in on-chip RAM. When the DTC is used, the RAME bit in SYSCR must not be cleared to 0.

8.8.3 DTCE Bit Setting

For DTCE bit setting, use bit manipulation instructions such as BSET and BCLR. If all interrupts are masked, multiple activation sources can be set at one time (only at the initial setting) by writing data after executing a dummy read on the relevant register.

Section 9 I/O Ports

Table 9.1 summarizes the port functions. The pins of each port also have other functions such as input/output or interrupt input pins of on-chip peripheral modules.

Each I/O port includes a data direction register (DDR) that controls input/output, a data register (DR) that stores output data, and a port register (PORT) used to read the pin states. The input-only ports do not have a DR or DDR register.

Ports A to D have built-in input pull-up MOS functions and input pull-up MOS control registers (PCR) to control the on/off state of input pull-up MOS.

Ports A to C include an open-drain control register (ODR) that controls the on/off state of the output buffer PMOS.

All the I/O ports can drive a single TTL load and a 30 pF capacitive load.

Table 9.1 Port Functions

Port	Description	Port and Other Functions Name	Input/Output and Output Type
Port 1	General I/O port also functioning as TPU_2, TPU_1, and TPU_0 I/O pins, PPG output pins, and interrupt input pins	P17/PO15/TIOCB2/TCLKD P16/PO14/TIOCA2/ $\overline{\text{IRQ1}}$ P15/PO13/TIOCB1/TCLKC P14/PO12/TIOCA1/ $\overline{\text{IRQ0}}$ P13/PO11/TIOCD0/TCLKB P12/PO10/TIOCC0/TCLKA P11/PO9/TIOCB0 P10/PO8/TIOCA0	
Port 3	General I/O port also functioning as SCI_0 I/O pins and interrupt input pins	P37 P36 P35/ $\overline{\text{IRQ5}}$ P34 P33 P32/SCK0/ $\overline{\text{IRQ4}}$ P31/RxD0 P30/TxD0	
Port 4	General input port also functioning as A/D converter analog inputs	P47/AN7 P46/AN6 P45/AN5 P44/AN4 P43/AN3 P42/AN2 P41/AN1 P40/AN0	

Port	Description	Port and Other Functions Name	Input/Output and Output Type
Port 7	General I/O port also functioning as TMR_0, TMR_1, TMR_2, and TMR_3 I/O pins	P77 P76 P75/TMO3 P74/TMO2 P73/TMO1 P72/TMO0 P71/TMCI23/TMRI23 P70/TMCI01/TMRI01	
Port 9	General input port also functioning as A/D converter analog inputs	P97/AN15 P96/AN14 P95/AN13 P94/AN12 P93/AN11 P92/AN10 P91/AN9 P90/AN8	
Port A	General I/O port also functioning as SCI_2 I/O pins	PA3/SCK2 PA2/RxD2 PA1/TxD2 PA0	Built-in input pull-up MOS Push-pull or open-drain output selectable
Port B	General I/O port also functioning as TPU_5, TPU_4, and TPU_3 I/O pins	PB7/TIOCB5 PB6/TIOCA5 PB5/TIOCB4 PB4/TIOCA4 PB3/TIOCD3 PB2/TIOCC3 PB1/TIOCB3 PB0/TIOCA3	Built-in input pull-up MOS Push-pull or open-drain output selectable

Port	Description	Port and Other Functions Name	Input/Output and Output Type
Port C	General I/O port also functioning as SSU_0 and SSU_1 I/O pins	PC7/ $\overline{SCS1}$	Built-in input pull-up MOS
		PC6/SSCK1	Push-pull or open-drain output selectable
		PC5/SSI1	
		PC4/SSO1	
		PC3/ $\overline{SCS0}$	
		PC2/SSCK0	
		PC1/SSI0	
		PC0/SSO0	
Port D	General I/O port	PD7	Built-in input pull-up MOS
		PD6	
		PD5	
		PD4	
		PD3	
		PD2	
		PD1	
		PD0	
Port F	General I/O port also functioning as interrupt input pins, an A/D converter start trigger input pin, and a system clock output pin (ϕ)	PF7/ ϕ	
		PF6	
		PF5	
		PF4	
		PF3/ $\overline{ADTRG}/\overline{IRQ3}$	
		PF2	
		PF1	
		PF0/ $\overline{IRQ2}$	

9.1 Port 1

Port 1 is an 8-bit I/O port and has the following registers.

- Port 1 data direction register (P1DDR)
- Port 1 data register (P1DR)
- Port 1 register (PORT1)

9.1.1 Port 1 Data Direction Register (P1DDR)

P1DDR is an 8-bit write-only register, the individual bits of which specify input or output for the pins of port 1.

P1DDR cannot be read; if it is, an undefined value will be read.

Bit	Bit Name	Initial Value	R/W	Description
7	P17DDR	0	W	When a pin is specified as a general purpose I/O port, setting these bits to 1 makes the corresponding port 1 pin an output pin. Clearing these bits to 0 makes the pin an input pin.
6	P16DDR	0	W	
5	P15DDR	0	W	
4	P14DDR	0	W	
3	P13DDR	0	W	
2	P12DDR	0	W	
1	P11DDR	0	W	
0	P10DDR	0	W	

9.1.2 Port 1 Data Register (P1DR)

P1DR is an 8-bit readable/writable register that stores output data for port 1 pins.

Bit	Bit Name	Initial Value	R/W	Description
7	P17DR	0	R/W	Output data for a pin is stored when the pin is specified as a general purpose I/O port.
6	P16DR	0	R/W	
5	P15DR	0	R/W	
4	P14DR	0	R/W	
3	P13DR	0	R/W	
2	P12DR	0	R/W	
1	P11DR	0	R/W	
0	P10DR	0	R/W	

9.1.3 Port 1 Register (PORT1)

PORT1 is an 8-bit read-only register that shows the pin states.

PORT1 cannot be modified.

Bit	Bit Name	Initial Value	R/W	Description
7	P17	Undefined*	R	If a port 1 read is performed while P1DDR bits are set to 1, the P1DR values are read. If a port 1 read is performed while P1DDR bits are cleared to 0, the pin states are read.
6	P16	Undefined*	R	
5	P15	Undefined*	R	
4	P14	Undefined*	R	
3	P13	Undefined*	R	
2	P12	Undefined*	R	
1	P11	Undefined*	R	
0	P10	Undefined*	R	

Note: * Determined by the states of pins P17 to P10.

9.1.4 Pin Functions

Port 1 pins also function as TPU I/O pins, PPG output pins, and interrupt input pins. The correspondence between the register specification and the pin functions is shown below.

Table 9.2 P17 Pin Function

TPU Channel 2 Setting*	Output	Input or Initial Value		
P17DDR	—	0	1	1
NDER15	—	—	0	1
Pin function	TIOCB2 output	P17 input	P17 output	PO15 output
		TIOCB2 input		
		TCLKD input		

Note: * For details on the TPU channel specification, refer to section 10, 16-Bit Timer Pulse Unit (TPU).

Table 9.3 P16 Pin Function

TPU Channel 2 Setting*	Output	Input or Initial Value		
P16DDR	—	0	1	1
NDER14	—	—	0	1
Pin function	TIOCA2 output	P16 input	P16 output	PO14 output
		TIOCA2 input		
		IRQ1 input		

Note: * For details on the TPU channel specification, refer to section 10, 16-Bit Timer Pulse Unit (TPU).

Table 9.4 P15 Pin Function

TPU Channel 1 Setting*	Output	Input or Initial Value		
P15DDR	—	0	1	1
NDER13	—	—	0	1
Pin function	TIOCB1 output	P15 input	P15 output	PO13 output
		TIOCB1 input		
		TCLKC input		

Note: * For details on the TPU channel specification, refer to section 10, 16-Bit Timer Pulse Unit (TPU).

Table 9.5 P14 Pin Function

TPU Channel 1 Setting*	Output	Input or Initial Value		
P14DDR	—	0	1	1
NDER12	—	—	0	1
Pin function	TIOCA1 output	P14 input	P14 output	PO12 output
		TIOCA1 input		
		$\overline{\text{IRQ0}}$ input		

Note: * For details on the TPU channel specification, refer to section 10, 16-Bit Timer Pulse Unit (TPU).

Table 9.6 P13 Pin Function

TPU Channel 0 Setting*	Output	Input or Initial Value		
P13DDR	—	0	1	1
NDER11	—	—	0	1
Pin function	TIOCD0 output	P13 input	P13 output	PO11 output
		TIOCD0 input		
		TCLKB input		

Note: * For details on the TPU channel specification, refer to section 10, 16-Bit Timer Pulse Unit (TPU).

Table 9.7 P12 Pin Function

TPU Channel 0 Setting*	Output	Input or Initial Value		
P12DDR	—	0	1	1
NDER10	—	—	0	1
Pin function	TIOCC0 output	P12 input	P12 output	PO10 output
		TIOCC0 input		
		TCLKA input		

Note: * For details on the TPU channel specification, refer to section 10, 16-Bit Timer Pulse Unit (TPU).

Table 9.8 P11 Pin Function

TPU Channel 0 Setting*	Output	Input or Initial Value		
P11DDR	—	0	1	1
NDER9	—	—	0	1
Pin function	TIOCB0 output	P11 input	P11 output	PO9 output
		TIOCB0 input		

Note: * For details on the TPU channel specification, refer to section 10, 16-Bit Timer Pulse Unit (TPU).

Table 9.9 P10 Pin Function

TPU Channel 0 Setting*	Output	Input or Initial Value		
P10DDR	—	0	1	1
NDER8	—	—	0	1
Pin function	TIOCA0 output	P10 input	P10 output	PO8 output
		TIOCA0 input		

Note: * For details on the TPU channel specification, refer to section 10, 16-Bit Timer Pulse Unit (TPU).

9.2 Port 3

Port 3 is an 8-bit I/O port and has the following registers.

- Port 3 data direction register (P3DDR)
- Port 3 data register (P3DR)
- Port 3 register (PORT3)
- Port 3 open-drain control register (P3ODR)

9.2.1 Port 3 Data Direction Register (P3DDR)

P3DDR is an 8-bit write-only register, the individual bits of which specify input or output for the pins of port 3.

Bit	Bit Name	Initial Value	R/W	Description
7	P37DDR	0	W	When a pin is specified as a general purpose I/O port, setting these bits to 1 makes the corresponding port 3 pin an output pin. Clearing these bits to 0 makes the pin an input pin.
6	P36DDR	0	W	
5	P35DDR	0	W	
4	P34DDR	0	W	
3	P33DDR	0	W	
2	P32DDR	0	W	
1	P31DDR	0	W	
0	P30DDR	0	W	

9.2.2 Port 3 Data Register (P3DR)

P3DR is an 8-bit readable/writable register that stores output data for port 3 pins.

Bit	Bit Name	Initial Value	R/W	Description
7	P37DR	0	R/W	Output data for a pin is stored when the pin is specified as a general I/O port.
6	P36DR	0	R/W	
5	P35DR	0	R/W	
4	P34DR	0	R/W	
3	P33DR	0	R/W	
2	P32DR	0	R/W	
1	P31DR	0	R/W	
0	P30DR	0	R/W	

9.2.3 Port 3 Register (PORT3)

PORT3 is an 8-bit read-only register that shows the pin states.

Bit	Bit Name	Initial Value	R/W	Description
7	P37	Undefined*	R	If a port 3 read is performed while P3DDR bits are set to 1, the P3DR values are read. If a port 3 read is performed while P3DDR bits are cleared to 0, the pin states are read.
6	P36	Undefined*	R	
5	P35	Undefined*	R	
4	P34	Undefined*	R	
3	P33	Undefined*	R	
2	P32	Undefined*	R	
1	P31	Undefined*	R	
0	P30	Undefined*	R	

Note: * Determined by the states of pins P37 to P30.

9.2.4 Port 3 Open-Drain Control Register (P3ODR)

P3ODR is an 8-bit readable/writable register that specifies the output type of port 3.

Bit	Bit Name	Initial Value	R/W	Description
7	P37ODR	0	R/W	When a pin is specified as an output port, setting the corresponding bits to 1 specifies pin output to open-drain and the input pull-up MOS to the off state. Clearing these bits to 0 specifies that to push-pull output.
6	P36ODR	0	R/W	
5	P35ODR	0	R/W	
4	P34ODR	0	R/W	
3	P33ODR	0	R/W	
2	P32ODR	0	R/W	
1	P31ODR	0	R/W	
0	P30ODR	0	R/W	

9.2.5 Pin Functions

Port 3 pins also function as SCI_0 I/O pins and interrupt input pins. The correspondence between the register specification and the pin functions is shown below.

Table 9.10 P37 Pin Function

P37DDR	0	1
Pin function	P37 input	P37 output

Table 9.11 P36 Pin Function

P36DDR	0	1
Pin function	P36 input	P36 output

Table 9.12 P35 Pin Function

P35DDR	0	1
Pin function	P35 input	P35 output
	IRQ5 input*	

Table 9.13 P34 Pin Function

P34DDR	0	1
Pin function	P34 input	P34 output

Table 9.14 P33 Pin Function

P33DDR	0	1
Pin function	P33 input	P33 output

Table 9.15 P32 Pin Function

CKE1 in SCR_0	0			1	
C/ \bar{A} in SMR_0	0			1	—
CKE0 in SCR_0	0		1	—	—
P32DDR	0	1	—	—	—
Pin function	P32 input	P32 output	SCK0 output	SCK0 output	SCK0 input
	$\overline{\text{IRQ4}}$ input*				

Table 9.16 P31 Pin Function

RE in SCR_0	0		1
P31DDR	0	1	—
Pin function	P31 input	P31 output	RxD0 output

Table 9.17 P30 Pin Function

TE in SCR_0	0		1
P30DDR	0	1	—
Pin function	P30 input	P30 output	TxD0 output

Note: * When used as an external interrupt input pin, do not use as an I/O pin for another function.

9.3 Port 4

Port 4 is an input-only port. Port 4 pins also function as A/D converter analog input pins. Port 4 has the following register.

- Port 4 register (PORT4)

9.3.1 Port 4 Register (PORT4)

PORT4 is an 8-bit read-only register that shows port 4 pin states.

Bit	Bit Name	Initial Value	R/W	Description
7	P47	Undefined*	R	The pin states are always read when a port 4 read is performed.
6	P46	Undefined*	R	
5	P45	Undefined*	R	
4	P44	Undefined*	R	
3	P43	Undefined*	R	
2	P42	Undefined*	R	
1	P41	Undefined*	R	
0	P40	Undefined*	R	

Note: * Determined by the states of pins P47 to P40.

9.4 Port 7

Port 7 is an 8-bit I/O port and has the following registers.

- Port 7 data direction register (P7DDR)
- Port 7 data register (P7DR)
- Port 7 register (PORT7)

9.4.1 Port 7 Data Direction Register (P7DDR)

P7DDR is an 8-bit write-only register, the individual bits of which specify input or output for the pins of port 7.

P7DDR cannot be read, if it is, an undefined value will be read.

Bit	Bit Name	Initial Value	R/W	Description
7	P77DDR	0	W	When a pin is specified as a general purpose I/O port, setting these bits to 1 makes the corresponding port 7 pin an output pin. Clearing these bits to 0 makes the pin an input pin.
6	P76DDR	0	W	
5	P75DDR	0	W	
4	P74DDR	0	W	
3	P73DDR	0	W	
2	P72DDR	0	W	
1	P71DDR	0	W	
0	P70DDR	0	W	

9.4.2 Port 7 Data Register (P7DR)

P7DR is an 8-bit readable/writable register that stores output data for port 7 pins.

Bit	Bit Name	Initial Value	R/W	Description
7	P77DR	0	R/W	Output data for a pin is stored when the pin is specified as a general purpose I/O port.
6	P76DR	0	R/W	
5	P75DR	0	R/W	
4	P74DR	0	R/W	
3	P73DR	0	R/W	
2	P72DR	0	R/W	
1	P71DR	0	R/W	
0	P70DR	0	R/W	

9.4.3 Port 7 Register (PORT7)

PORT7 is an 8-bit read-only register that shows the pin states.

PORT7 cannot be modified.

Bit	Bit Name	Initial Value	R/W	Description
7	P77	Undefined*	R	If a port 7 read is performed while P7DDR bits are set to 1, the P7DR values are read. If a port 7 read is performed while P7DDR bits are cleared to 0, the pin states are read.
6	P76	Undefined*	R	
5	P75	Undefined*	R	
4	P74	Undefined*	R	
3	P73	Undefined*	R	
2	P72	Undefined*	R	
1	P71	Undefined*	R	
0	P70	Undefined*	R	

Note: * Determined by the states of pins P77 to P70.

9.4.4 Pin Functions

Port 7 pins also function as TMR_3, TMR_2, TMR_1, and TMR_0 I/O pins. The correspondence between the register specification and the pin functions is shown below.

Table 9.18 P77 Pin Function

P77DDR	0	1
Pin function	P77 input	P77 output

Table 9.19 P76 Pin Function

P76DDR	0	1
Pin function	P76 input	P76 output

Table 9.20 P75 Pin Function

OS3 to OS0 in TCSR_3	All 0		Any of 1
P75DDR	0	1	—
Pin function	P75 input	P75 output	TMO3 output

Table 9.21 P74 Pin Function

OS3 to OS0 in TCSR_2	All 0		Any of 1
P74DDR	0	1	—
Pin function	P74 input	P74 output	TMO2 output

Table 9.22 P73 Pin Function

OS3 to OS0 in TCSR_1	All 0		Any of 1
P73DDR	0	1	—
Pin function	P73 input	P73 output	TMO1 output

Table 9.23 P72 Pin Function

OS3 to OS0 in TCSR_0	All 0		Any of 1
P72DDR	0	1	—
Pin function	P72 input	P72 output	TMO0 output

Table 9.24 P71 Pin Function

P71DDR	0	1
Pin function	P71 input	P71 output
	TMCI23 input/TMRI23 input	

Table 9.25 P70 Pin Function

P70DDR	0	1
Pin function	P70 input	P70 output
	TMCI01 input/TMRI01 input	

9.5 Port 9

Port 9 is an input-only port. Port 9 pins also function as A/D converter analog input pins. Port 9 has the following register.

- Port 9 register (PORT9)

9.5.1 Port 9 Register (PORT9)

PORT9 is an 8-bit read-only register that shows port 9 pin states.

PORT9 cannot be modified.

Bit	Bit Name	Initial Value	R/W	Description
7	P97	Undefined*	R	The pin states are always read when a port 9 read is performed.
6	P96	Undefined*	R	
5	P95	Undefined*	R	
4	P94	Undefined*	R	
3	P93	Undefined*	R	
2	P92	Undefined*	R	
1	P91	Undefined*	R	
0	P90	Undefined*	R	

Note: * Determined by the states of pins P97 to P90.

9.6 Port A

Port A is a 4-bit I/O port that also has other functions. Port A has the following registers.

- Port A data direction register (PADDR)
- Port A data register (PADR)
- Port A register (PORTA)
- Port A pull-up MOS control register (PAPCR)
- Port A open-drain control register (PAODR)

9.6.1 Port A Data Direction Register (PADDR)

PADDR is an 8-bit write-only register, the individual bits of which specify whether the pins of port A are used for input or output.

Bit	Bit Name	Initial Value	R/W	Description
7 to 4	—	Undefined	—	Reserved These bits are read as undefined value and cannot be modified.
3	PA3DDR	0	W	When a pin is specified as a general purpose I/O port, setting these bits to 1 makes the corresponding port A pin an output pin. Clearing these bits to 0 makes the pin an input pin.
2	PA2DDR	0	W	
1	PA1DDR	0	W	
0	PA0DDR	0	W	

9.6.2 Port A Data Register (PADR)

PADR is an 8-bit readable/writable register that stores output data for port A pins.

Bit	Bit Name	Initial Value	R/W	Description
7 to 4	—	Undefined	—	Reserved These bits are read as an undefined value and cannot be modified.
3	PA3DR	0	R/W	Output data for a pin is stored when the pin is specified as a general purpose I/O port.
2	PA2DR	0	R/W	
1	PA1DR	0	R/W	
0	PA0DR	0	R/W	

9.6.3 Port A Register (PORTA)

PORTA is an 8-bit read-only register that shows port A pin states.

Bit	Bit Name	Initial Value	R/W	Description
7 to 4	—	Undefined	—	Reserved These bits are read as an undefined value.
3	PA3	0	R	If a port A read is performed while PADDR bits are set to 1, the PADR values are read. If a port A read is performed while PADDR bits are cleared to 0, the pin states are read.
2	PA2	0	R	
1	PA1	0	R	
0	PA0	0	R	

Note: * Determined by the states of pins PA3 to PA0.

9.6.4 Port A Pull-Up MOS Control Register (PAPCR)

PAPCR is an 8-bit register that controls the input pull-up MOS function.

Bit	Bit Name	Initial Value	R/W	Description
7 to 4	—	Undefined	—	Reserved These bits are read as an undefined value and cannot be modified.
3	PA3PCR	0	R/W	When a pin is specified as an input port, setting the corresponding bit to 1 turns on the input pull-up MOS for that pin.
2	PA2PCR	0	R/W	
1	PA1PCR	0	R/W	
0	PA0PCR	0	R/W	

9.6.5 Port A Open-Drain Control Register (PAODR)

PAODR is an 8-bit readable/writable register that specifies the output type of port A.

Bit	Bit Name	Initial Value	R/W	Description
7 to 4	—	Undefined	—	Reserved These bits are read as an undefined value and cannot be modified.
3	PA3ODR	0	R/W	When a pin is specified as an output port, setting the corresponding bits to 1 specifies pin output to open-drain and the input pull-up MOS to the off state. Clearing these bits to 0 specifies that to push-pull output.
2	PA2ODR	0	R/W	
1	PA1ODR	0	R/W	
0	PA0ODR	0	R/W	

9.6.6 Pin Functions

Port A pins also function as SCI_2 I/O pins. The correspondence between the register specification and the pin functions is shown below.

Table 9.26 PA3 Pin Function

CKE1 in SCR_2	0				1
C/\bar{A} in SMR_2	0			1	—
CKE0 in SCR_2	0		1	—	—
PA3DDR	0	1	—	—	—
Pin function	PA3 input	PA3 output	SCK2 output	SCK2 output	SCK2 input

Table 9.27 PA2 Pin Function

RE in SCR_2	0		1
PA2DDR	0	1	—
Pin function	PA2 input	PA2 output	RxD2 input

Table 9.28 PA1 Pin Function

TE in SCR_2	0		1
PA1DDR	0	1	—
Pin function	PA1 input	PA1 output	TxD2 output

Table 9.29 PA0 Pin Function

PA0DDR	0	1
Pin function	PA0 input	PA0 output

9.7 Port B

Port B is an 8-bit I/O port that also has other functions. Port B has the following registers.

- Port B data direction register (PBDDR)
- Port B data register (PBDR)
- Port B register (PORTB)
- Port B pull-up MOS control register (PBPCR)
- Port B open-drain control register (PBODR)

9.7.1 Port B Data Direction Register (PBDDR)

PBDDR is an 8-bit write-only register, the individual bits of which specify whether the pins of port B are used for input or output.

Bit	Bit Name	Initial Value	R/W	Description
7	PB7DDR	0	W	When a pin is specified as a general purpose I/O port, setting these bits to 1 makes the corresponding port 1 pin an output pin. Clearing these bits to 0 makes the pin an input pin.
6	PB6DDR	0	W	
5	PB5DDR	0	W	
4	PB4DDR	0	W	
3	PB3DDR	0	W	
2	PB2DDR	0	W	
1	PB1DDR	0	W	
0	PB0DDR	0	W	

9.7.2 Port B Data Register (PBDR)

PBDR is an 8-bit readable/writable register that stores output data for the port B pins.

Bit	Bit Name	Initial Value	R/W	Description
7	PB7DR	0	R/W	Output data for a pin is stored when the pin is specified as a general purpose I/O port.
6	PB6DR	0	R/W	
5	PB5DR	0	R/W	
4	PB4DR	0	R/W	
3	PB3DR	0	R/W	
2	PB2DR	0	R/W	
1	PB1DR	0	R/W	
0	PB0DR	0	R/W	

9.7.3 Port B Register (PORTB)

PORTB is an 8-bit read-only register that shows port B pin states.

Bit	Bit Name	Initial Value	R/W	Description
7	PB7	0	R	If a port B read is performed while PBDDR bits are set to 1, the PBDR values are read. If a port B read is performed while PBDDR bits are cleared to 0, the pin states are read.
6	PB6	0	R	
5	PB5	0	R	
4	PB4	0	R	
3	PB3	0	R	
2	PB2	0	R	
1	PB1	0	R	
0	PB0	0	R	

Note: * Determined by the states of pins PB7 to PB0.

9.7.4 Port B Pull-Up MOS Control Register (PBPCR)

PBPCR is an 8-bit readable/writable register that controls the on/off state of input pull-up MOS of port B.

Bit	Bit Name	Initial Value	R/W	Description
7	PB7PCR	0	R/W	When a pin is specified as an input port, setting the corresponding bits to 1 turns on the input pull-up MOS for that pin.
6	PB6PCR	0	R/W	
5	PB5PCR	0	R/W	
4	PB4PCR	0	R/W	
3	PB3PCR	0	R/W	
2	PB2PCR	0	R/W	
1	PB1PCR	0	R/W	
0	PB0PCR	0	R/W	

9.7.5 Port B Open-Drain Control Register (PBODR)

PBODR is an 8-bit readable/writable register that specifies the output type of port B.

Bit	Bit Name	Initial Value	R/W	Description
7	PB7ODR	0	R/W	When a pin function is specified as an output port, setting the corresponding bits to 1 specifies pin output as open-drain and the input pull-up MOS to the off state. Clearing these bits to 0 specifies push-pull output.
6	PB6ODR	0	R/W	
5	PB5ODR	0	R/W	
4	PB4ODR	0	R/W	
3	PB3ODR	0	R/W	
2	PB2ODR	0	R/W	
1	PB1ODR	0	R/W	
0	PB0ODR	0	R/W	

9.7.6 Pin Functions

Port B pins also function as TPU I/O pins. The correspondence between the register specification and the pin functions is shown below.

Table 9.30 PB7 Pin Function

TPU channel 5 setting*	Output	Input or Initial Value	
PB7DDR	—	0	1
Pin function	TIOCB5 output	PB7 input	PB7 output
		TIOCB5 input	

Note: * For details on the TPU channel specification, refer to section 10, 16-Bit Timer Pulse Unit (TPU).

Table 9.31 PB6 Pin Function

TPU channel 5 setting*	Output	Input or Initial Value	
PB6DDR	—	0	1
Pin function	TIOCA5 output	PB6 input	PB6 output
		TIOCA5 input	

Note: * For details on the TPU channel specification, refer to section 10, 16-Bit Timer Pulse Unit (TPU).

Table 9.32 PB5 Pin Function

TPU channel 4 setting*	Output	Input or Initial Value	
PB5DDR	—	0	1
Pin function	TIOCB4 output	PB5 input	PB5 output
		TIOCB4 input	

Note: * For details on the TPU channel specification, refer to section 10, 16-Bit Timer Pulse Unit (TPU).

Table 9.33 PB4 Pin Function

TPU channel 4 setting*	Output	Input or Initial Value	
PB4DDR	—	0	1
Pin function	TIOCA4 output	PB4 input	PB4 output
		TIOCA4 input	

Note: * For details on the TPU channel specification, refer to section 10, 16-Bit Timer Pulse Unit (TPU).

Table 9.34 PB3 Pin Function

TPU channel 3 setting*	Output	Input or Initial Value	
PB3DDR	—	0	1
Pin function	TIOCD3 output	PB3 input	PB3 output
		TIOCD3 input	

Note: * For details on the TPU channel specification, refer to section 10, 16-Bit Timer Pulse Unit (TPU).

Table 9.35 PB2 Pin Function

TPU channel 3 setting*	Output	Input or Initial Value	
PB2DDR	—	0	1
Pin function	TIOCC3 output	PB2 input	PB2 output
		TIOCC3 input	

Note: * For details on the TPU channel specification, refer to section 10, 16-Bit Timer Pulse Unit (TPU).

Table 9.36 PB1 Pin Function

TPU channel 3 setting*	Output	Input or Initial Value	
PB1DDR	—	0	1
Pin function	TIOCB3 output	PB1 input	PB1 output
		TIOCB3 input	

Note: * For details on the TPU channel specification, refer to section 10, 16-Bit Timer Pulse Unit (TPU).

Table 9.37 PB0 Pin Function

TPU channel 3 setting*	Output	Input or Initial Value	
PB0DDR	—	0	1
Pin function	TIOCA3 output	PB0 input	PB0 output
		TIOCA3 input	

Note: * For details on the TPU channel specification, refer to section 10, 16-Bit Timer Pulse Unit (TPU).

9.8 Port C

Port C is an 8-bit I/O port that also has other functions. Port C has the following registers.

- Port C data direction register (PCDDR)
- Port C data register (PCDR)
- Port C register (PORTC)
- Port C pull-up MOS control register (PCPCR)
- Port C open-drain control register (PCODR)

9.8.1 Port C Data Direction Register (PCDDR)

PCDDR is an 8-bit write-only register, the individual bits of which specify whether the pins of port C are used for input or output.

Bit	Bit Name	Initial Value	R/W	Description
7	PC7DDR	0	W	When a pin is specified as a general purpose I/O port, setting these bits to 1 makes the corresponding port 1 pin an output pin. Clearing these bits to 0 makes the pin an input pin.
6	PC6DDR	0	W	
5	PC5DDR	0	W	
4	PC4DDR	0	W	
3	PC3DDR	0	W	
2	PC2DDR	0	W	
1	PC1DDR	0	W	
0	PC0DDR	0	W	

9.8.2 Port C Data Register (PCDR)

PCDR is an 8-bit readable/writable register that stores output data for the port C pins.

Bit	Bit Name	Initial Value	R/W	Description
7	PC7DR	0	R/W	Output data for a pin is stored when the pin is specified as a general purpose I/O port.
6	PC6DR	0	R/W	
5	PC5DR	0	R/W	
4	PC4DR	0	R/W	
3	PC3DR	0	R/W	
2	PC2DR	0	R/W	
1	PC1DR	0	R/W	
0	PC0DR	0	R/W	

9.8.3 Port C Register (PORTC)

PORTC is an 8-bit read-only register that shows port C pin states.

Bit	Bit Name	Initial Value	R/W	Description
7	PC7	0	R	If a port C read is performed while PCDDR bits are set to 1, the PCDR values are read. If a port C read is performed while PCDDR bits are cleared to 0, the pin states are read.
6	PC6	0	R	
5	PC5	0	R	
4	PC4	0	R	
3	PC3	0	R	
2	PC2	0	R	
1	PC1	0	R	
0	PC0	0	R	

Note: * Determined by the states of pins PC7 to PC0.

9.8.4 Port C Pull-Up MOS Control Register (PCPCR)

PCPCR is an 8-bit readable/writable register that controls the on/off state of input pull-up MOS of port C.

Bit	Bit Name	Initial Value	R/W	Description
7	PC7PCR	0	R/W	When a pin is specified as an input port, setting the corresponding bit to 1 turns on the input pull-up MOS for that pin.
6	PC6PCR	0	R/W	
5	PC5PCR	0	R/W	
4	PC4PCR	0	R/W	
3	PC3PCR	0	R/W	
2	PC2PCR	0	R/W	
1	PC1PCR	0	R/W	
0	PC0PCR	0	R/W	

9.8.5 Port C Open-Drain Control Register (PCODR)

PCODR is an 8-bit readable/writable register that specifies an output type of port C.

Bit	Bit Name	Initial Value	R/W	Description
7	PC7ODR	0	R/W	When a pin is specified as an output port, setting the corresponding bits to 1 specifies pin output as open-drain and the input pull-up MOS to the off state. Clearing these bits to 0 specifies push-pull output.
6	PC6ODR	0	R/W	
5	PC5ODR	0	R/W	
4	PC4ODR	0	R/W	
3	PC3ODR	0	R/W	
2	PC2ODR	0	R/W	
1	PC1ODR	0	R/W	
0	PC0ODR	0	R/W	

9.8.6 Pin Functions

Port C pins also function as SSU_1 and SSU_0 I/O pins. The correspondence between the register specification and the pin functions is shown below.

Table 9.38 PC7 Pin Function

CSS1	0				1	
CSS0	0		1		0	1
PC7DDR	0	1	—	—	—	
Pin function	PC7 input	PC7 output	$\overline{SCS1}$ input	$\overline{SCS1}$ input/output auto switch	$\overline{SCS1}$ output	

Table 9.39 PC6 Pin Function

MSS	0				1	
SCKS	0		1		1	0
PC6DDR	0	1	—	—	—	
Pin function	PC6 input	PC6 output	SSCK1 input	SSCK1 output	Setting prohibited	

Table 9.40 PC5 Pin Function

MSS	0						1					
BIDE	0			1			0			1		
RE	—						0		1		—	
TE	0		1		—		—				—	
PC5DDR	0	1	—		0	1	0	1	—	0	1	
$\overline{SCS1}$ input	—		0	1	—							
Pin function	PC5 input	PC5 output	SS11 output	SS11 Hi-Z	PC5 input	PC5 output	PC5 input	PC5 output	SS11 input	PC5 input	PC5 output	

Table 9.41 PC4 Pin Function

MSS	0			1			—			0	1		
BIDE	0						1						
RE	0	1	—			0	1	0					
TE	—			0	1	0	0	1	1				
PC4DDR	0	1	—	0	1	—	0	1	—				
SCST $\bar{1}$ input	—									0	1	—	
Pin function	PC4 input	PC4 output	SSO1 input	PC4 input	PC4 output	SSO1 output	PC4 input	PC4 output	SSO1 input	Setting prohibited	SSO1 output	SSO1 Hi-Z	SSO1 output

Table 9.42 PC3 Pin Function

CSS1	0				1				
CSS0	0			1			0	1	
PC3DDR	0	1		—		—		—	
Pin function	PC3 input		PC3 output		$\overline{\text{SCS0}}$ input		$\overline{\text{SCS0}}$ input/output auto switch		$\overline{\text{SCS0}}$ output

Table 9.43 PC2 Pin Function

MSS	0				1				
SCKS	0			1			1	0	
PC2DDR	0	1		—		—		—	
Pin function	PC2 input		PC2 output		SSCK0 input		SSCK0 output		Setting prohibited

Table 9.44 PC1 Pin Function

MSS	0						1					
BIDE	0			1			0			1		
RE	—						0		1		—	
TE	0		1		—		—			—		
PC1DDR	0	1	—			0	1	0	1	—	0	1
SCS0 input	—		0	1		—						
Pin function	PC1 input	PC1 output	SSI0 output	SSI0 Hi-Z	PC1 input	PC1 output	PC1 input	PC1 output	SSI0 input	PC1 input	PC1 output	

Table 9.45 PC0 Pin Function

MSS	0			1			—			0	1		
BIDE	0						1						
RE	0	1		—			0	1		0			
TE	—			0	1		0	0	1	1			
PC0DDR	0	1	—	0	1	—	0	1	—				
SCS0 input	—									0	1	—	
Pin function	PC0 input	PC0 output	SSO0 input	PC0 input	PC0 output	SSO0 output	PC0 input	PC0 output	SSO0 input	Setting prohibited	SSO0 output	SSO0 Hi-Z	SSO0 output

9.9 Port D

Port D is an 8-bit I/O port that also functions as the realtime input port pins.

The realtime input port stores the pin states of port D in PDRTIDR using the $\overline{\text{IRQ3}}$ pin as the trigger input. The falling, rising, or both edges of the $\overline{\text{IRQ3}}$ pin can be used as a trigger timing.

Port D has the following registers.

- Port D data direction register (PDDDR)
- Port D data register (PDDR)
- Port D register (PORTD)
- Port D pull-up MOS control register (PDPCR)
- Port D realtime input data register (PDRTIDR)

9.9.1 Port D Data Direction Register (PDDDR)

PDDDR is an 8-bit write-only register, the individual bits of which specify whether the pins of port D are used for input or output.

Bit	Bit Name	Initial Value	R/W	Description
7	PD7DDR	0	W	When a pin is specified as a general purpose I/O port, setting these bits to 1 makes the corresponding port 1 pin an output pin. Clearing these bits to 0 makes the pin an input pin.
6	PD6DDR	0	W	
5	PD5DDR	0	W	
4	PD4DDR	0	W	
3	PD3DDR	0	W	
2	PD2DDR	0	W	
1	PD1DDR	0	W	
0	PD0DDR	0	W	

9.9.2 Port D Data Register (PDDR)

PDDR is an 8-bit readable/writable register that stores output data for the port D pins.

Bit	Bit Name	Initial Value	R/W	Description
7	PD7DR	0	R/W	Output data for a pin is stored when the pin is specified as a general purpose I/O port.
6	PD6DR	0	R/W	
5	PD5DR	0	R/W	
4	PD4DR	0	R/W	
3	PD3DR	0	R/W	
2	PD2DR	0	R/W	
1	PD1DR	0	R/W	
0	PD0DR	0	R/W	

9.9.3 Port D Register (PORTD)

PORTD is an 8-bit read-only register that shows port D pin states.

Bit	Bit Name	Initial Value	R/W	Description
7	PD7	Undefined*	R	If a port D read is performed while PDDDR bits are set to 1, the PDDR values are read. If a port D read is performed while PDDDR bits are cleared to 0, the pin states are read.
6	PD6	Undefined*	R	
5	PD5	Undefined*	R	
4	PD4	Undefined*	R	
3	PD3	Undefined*	R	
2	PD2	Undefined*	R	
1	PD1	Undefined*	R	
0	PD0	Undefined*	R	

Note: * Determined by the states of pins PD7 to PD0.

9.9.4 Port D Pull-Up MOS Control Register (PDPCR)

PDPCR is an 8-bit readable/writable register that controls on/off states of the input pull-up MOS of port D.

Bit	Bit Name	Initial Value	R/W	Description
7	PD7PCR	0	R/W	When the pin is in its input state, the input pull-up MOS of the input pin is on when the corresponding bits are set to 1.
6	PD6PCR	0	R/W	
5	PD5PCR	0	R/W	
4	PD4PCR	0	R/W	
3	PD3PCR	0	R/W	
2	PD2PCR	0	R/W	
1	PD1PCR	0	R/W	
0	PD0PCR	0	R/W	

9.9.5 Port D RealTime Input Data Register (PDRTIDR)

The realtime input port stores the pin states of port D in PDRTIDR using the $\overline{\text{IRQ3}}$ pin as the trigger input. The falling, rising, or both edges of the $\overline{\text{IRQ3}}$ pin can be specified as a trigger timing by bits 7 and 6 in the IRQ sense control register L (ISCRL). For details of this setting, see section 5.3.3, IRQ Sense Control Registers H and L (ISCRH, ISCRL).

Bit	Bit Name	Initial Value	R/W	Description
7	PDRTIDR7	0	R/W	Stores pin states using the $\overline{\text{IRQ3}}$ pin as a trigger input.
6	PDRTIDR6	0	R/W	
5	PDRTIDR5	0	R/W	
4	PDRTIDR4	0	R/W	
3	PDRTIDR3	0	R/W	
2	PDRTIDR2	0	R/W	
1	PDRTIDR1	0	R/W	
0	PDRTIDR0	0	R/W	

9.10 Port F

Port F is an 8-bit I/O port that also has other functions. Port F has the following registers.

- Port F data direction register (PFDDR)
- Port F data register (PFDR)
- Port F register (PORTF)

9.10.1 Port F Data Direction Register (PFDDR)

PFDDR is an 8-bit write-only register, the individual bits of which specify whether the pins of port F are used for input or output.

Bit	Bit Name	Initial Value	R/W	Description
7	PF7DDR	0	W	When a pin is specified as a general purpose I/O port, setting this bit to 1 makes the PF7 pin a ϕ output pin. Clearing this bit to 0 makes the pin an input pin.
6	PF6DDR	0	W	When a pin is specified as a general purpose I/O port, setting these bits to 1 makes the corresponding port F pin an output pin. Clearing these bits to 0 makes the pin an input pin.
5	PF5DDR	0	W	
4	PF4DDR	0	W	
3	PF3DDR	0	W	
2	PF2DDR	0	W	
1	PF1DDR	0	W	
0	PF0DDR	0	W	

9.10.2 Port F Data Register (PFDR)

PFDR is an 8-bit readable/writable register that stores output data for the port F pins.

Bit	Bit Name	Initial Value	R/W	Description
7	—	0	R/W	Reserved The write value should always be 0.
6	PF6DR	0	R/W	Output data for a pin is stored when the pin is specified as a general purpose I/O port.
5	PF5DR	0	R/W	
4	PF4DR	0	R/W	
3	PF3DR	0	R/W	
2	PF2DR	0	R/W	
1	PF1DR	0	R/W	
0	PF0DR	0	R/W	

9.10.3 Port F Register (PORTF)

PORTF is an 8-bit read-only register that shows port F pin states.

PORTF cannot be modified.

Bit	Bit Name	Initial Value	R/W	Description
7	PF7	Undefined*	R	If a port F read is performed while PFDDR bits are set to 1, the PFDR values are read. If a port F read is performed while PFDDR bits are cleared to 0, the pin states are read.
6	PF6	Undefined*	R	
5	PF5	Undefined*	R	
4	PF4	Undefined*	R	
3	PF3	Undefined*	R	
2	PF2	Undefined*	R	
1	PF1	Undefined*	R	
0	PF0	Undefined*	R	

Note: * Determined by the states of pins PF7 to PF0.

9.10.4 Pin Functions

Port F is an 8-bit I/O port. Port F pins also function as external interrupt input, $\overline{\text{IRQ3}}$ and $\overline{\text{IRQ2}}$, A/D trigger input ($\overline{\text{ADTRG}}$), and system clock output (ϕ).

Table 9.46 PF7 Pin Function

PF7DDR	0	1
Pin function	PF7 input	ϕ output

Table 9.47 PF6 Pin Function

PF6DDR	0	1
Pin function	PF6 input	PF6 output

Table 9.48 PF5 Pin Function

PF5DDR	0	1
Pin function	PF5 input	PF5 output

Table 9.49 PF4 Pin Function

PF4DDR	0	1
Pin function	PF4 input	PF4 output

Table 9.50 PF3 Pin Function

PF3DDR	0	1
Pin function	PF3 input	PF3 output
	$\overline{\text{ADTRG}}$ input* ¹	
	$\overline{\text{IRQ3}}$ input* ²	

Notes: 1. $\overline{\text{ADTRG}}$ input when TRGS0 = TRGS1 = 1.

2. When used as an external interrupt input pin, do not use as an I/O pin for another function. This pin also functions as the trigger input for the realtime input port.

Table 9.51 PF2 Pin Function

PF2DDR	0	1
Pin function	PF2 input	PF2 output

Table 9.52 PF1 Pin Function

PF1DDR	0	1
Pin function	PF1 input	PF1 output

Table 9.53 PF0 Pin Function

PF0DDR	0	1
Pin function	PF0 input	PF0 output
	$\overline{\text{IRQ2}}$ input*	

Note: * When used as an external interrupt input pin, do not use as an I/O pin for another function.

Section 10 16-Bit Timer Pulse Unit (TPU)

This LSI has an on-chip 16-bit timer pulse unit (TPU) comprised of six 16-bit timer channels.

The function list of the 16-bit timer unit and its block diagram are shown in table 10.1 and figure 10.1, respectively.

10.1 Features

- Maximum 16-pulse input/output
- Selection of 8 counter input clocks for each channel
- The following operations can be set for each channel:
 - Waveform output at compare match
 - Input capture function
 - Counter clear operation
 - Synchronous operation:
 - Multiple timer counters (TCNT) can be written to simultaneously
 - Simultaneous clearing by compare match and input capture is possible
 - Register simultaneous input/output is possible by synchronous counter operation
 - A maximum 15-phase PWM output is possible in combination with synchronous operation
- Buffer operation settable for channels 0 and 3
- Phase counting mode settable independently for each of channels 1, 2, 4, and 5
- Cascaded operation
- Fast access via internal 16-bit bus
- 26 interrupt sources
- Automatic transfer of register data
- Programmable pulse generator (PPG) output trigger can be generated
- A/D converter conversion start trigger can be generated
- Module stop mode can be set

Table 10.1 TPU Functions

Item	Channel 0	Channel 1	Channel 2	Channel 3	Channel 4	Channel 5
Count clock	$\phi/1$	$\phi/1$	$\phi/1$	$\phi/1$	$\phi/1$	$\phi/1$
	$\phi/4$	$\phi/4$	$\phi/4$	$\phi/4$	$\phi/4$	$\phi/4$
	$\phi/16$	$\phi/16$	$\phi/16$	$\phi/16$	$\phi/16$	$\phi/16$
	$\phi/64$	$\phi/64$	$\phi/64$	$\phi/64$	$\phi/64$	$\phi/64$
	TCLKA	$\phi/256$	$\phi/1024$	$\phi/256$	$\phi/1024$	$\phi/256$
	TCLKB	TCLKA	TCLKA	$\phi/1024$	TCLKA	TCLKA
	TCLKC	TCLKB	TCLKB	$\phi/4096$	TCLKC	TCLKC
	TCLKD		TCLKC	TCLKA		TCLKD
General registers (TGR)	TGRA_0	TGRA_1	TGRA_2	TGRA_3	TGRA_4	TGRA_5
	TGRB_0	TGRB_1	TGRB_2	TGRB_3	TGRB_4	TGRB_5
General registers/ buffer registers	TGRC_0	—	—	TGRC_3	—	—
	TGRD_0			TGRD_3		
I/O pins	TIOCA0	TIOCA1	TIOCA2	TIOCA3	TIOCA4	TIOCA5
	TIOCB0	TIOCB1	TIOCB2	TIOCB3	TIOCB4	TIOCB5
	TIOCC0			TIOCC3		
	TIOCD0			TIOCD3		
Counter clear function	TGR compare match or input capture	TGR compare match or input capture	TGR compare match or input capture	TGR compare match or input capture	TGR compare match or input capture	TGR compare match or input capture
Compare match output	0 output	○	○	○	○	○
	1 output	○	○	○	○	○
	Toggle output	○	○	○	○	○
Input capture function	○	○	○	○	○	○
Synchronous operation	○	○	○	○	○	○
PWM mode	○	○	○	○	○	○
Phase counting mode	—	○	○	—	○	○
Buffer operation	○	—	—	○	—	—

Item	Channel 0	Channel 1	Channel 2	Channel 3	Channel 4	Channel 5
DTC activation	TGR compare match or input capture	TGR compare match or input capture	TGR compare match or input capture	TGR compare match or input capture	TGR compare match or input capture	TGR compare match or input capture
A/D converter trigger	TGRA_0 compare match or input capture	TGRA_1 compare match or input capture	TGRA_2 compare match or input capture	TGRA_3 compare match or input capture	TGRA_4 compare match or input capture	TGRA_5 compare match or input capture
PPG trigger	TGRA_0/ TGRB_0 compare match or input capture	TGRA_1/ TGRB_1 compare match or input capture	TGRA_2/ TGRB_2 compare match or input capture	TGRA_3/ TGRB_3 compare match or input capture	—	—
Interrupt sources	5 sources • Compare match or input capture 0A • Compare match or input capture 0B • Compare match or input capture 0C • Compare match or input capture 0D • Overflow	4 sources • Compare match or input capture 1A • Compare match or input capture 1B • Overflow • Underflow	4 sources • Compare match or input capture 2A • Compare match or input capture 2B • Overflow • Underflow	5 sources • Compare match or input capture 3A • Compare match or input capture 3B • Compare match or input capture 3C • Compare match or input capture 3D • Overflow	4 sources • Compare match or input capture 4A • Compare match or input capture 4B • Overflow • Underflow	4 sources • Compare match or input capture 5A • Compare match or input capture 5B • Overflow • Underflow

Legend:

○: Possible

—: Not possible

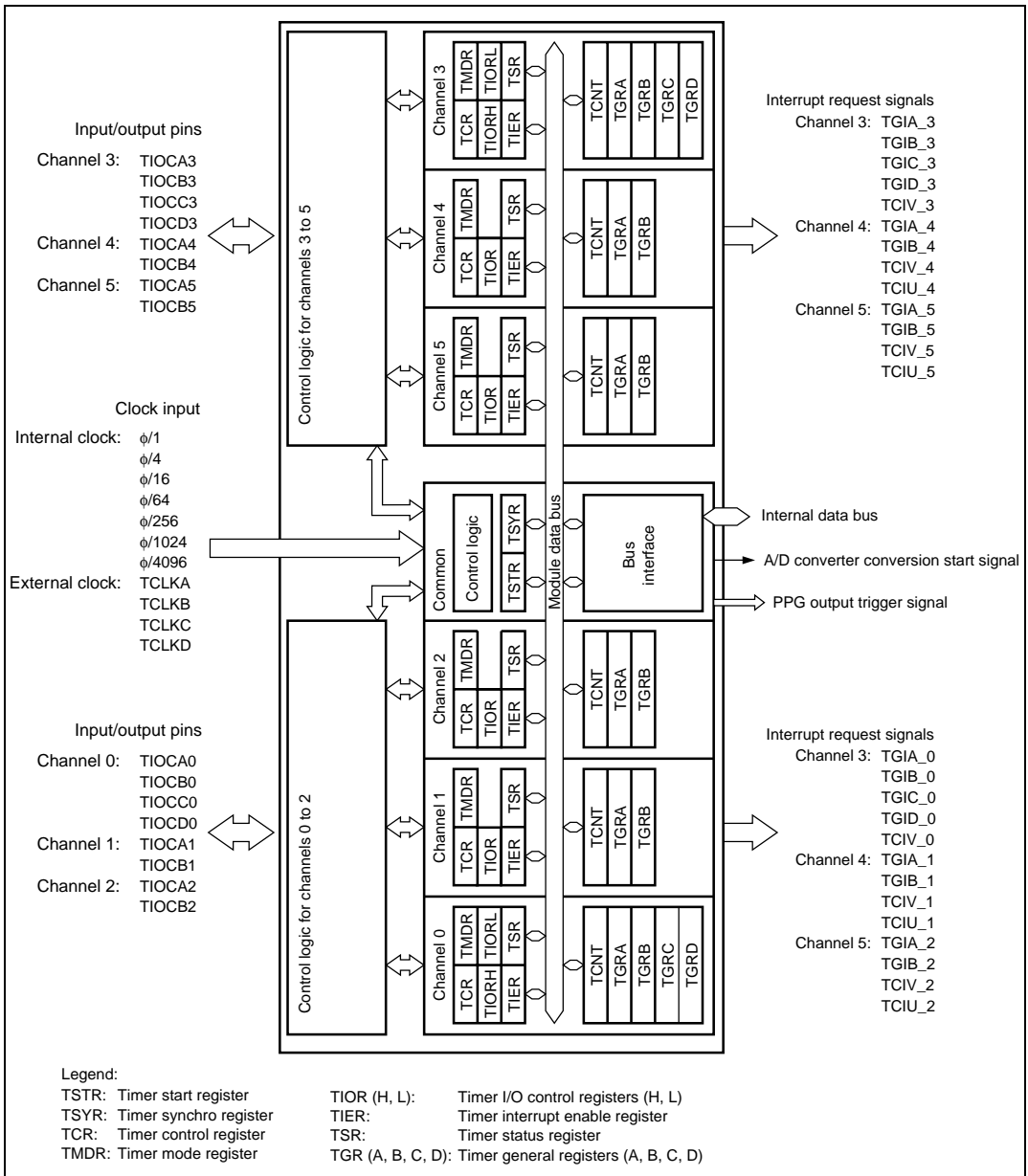

Figure 10.1 Block Diagram of TPU

10.2 Input/Output Pins

Table 10.2 TPU Pins

Channel	Symbol	I/O	Function
All	TCLKA	Input	External clock A input pin (Channel 1 and 5 phase counting mode A phase input)
	TCLKB	Input	External clock B input pin (Channel 1 and 5 phase counting mode B phase input)
	TCLKC	Input	External clock C input pin (Channel 2 and 4 phase counting mode A phase input)
	TCLKD	Input	External clock D input pin (Channel 2 and 4 phase counting mode B phase input)
0	TIOCA0	I/O	TGRA_0 input capture input/output compare output/PWM output pin
	TIOCB0	I/O	TGRB_0 input capture input/output compare output/PWM output pin
	TIOCC0	I/O	TGRC_0 input capture input/output compare output/PWM output pin
	TIOCD0	I/O	TGRD_0 input capture input/output compare output/PWM output pin
1	TIOCA1	I/O	TGRA_1 input capture input/output compare output/PWM output pin
	TIOCB1	I/O	TGRB_1 input capture input/output compare output/PWM output pin
2	TIOCA2	I/O	TGRA_2 input capture input/output compare output/PWM output pin
	TIOCB2	I/O	TGRB_2 input capture input/output compare output/PWM output pin
3	TIOCA3	I/O	TGRA_3 input capture input/output compare output/PWM output pin
	TIOCB3	I/O	TGRB_3 input capture input/output compare output/PWM output pin
	TIOCC3	I/O	TGRC_3 input capture input/output compare output/PWM output pin
	TIOCD3	I/O	TGRD_3 input capture input/output compare output/PWM output pin
4	TIOCA4	I/O	TGRA_4 input capture input/output compare output/PWM output pin
	TIOCB4	I/O	TGRB_4 input capture input/output compare output/PWM output pin
5	TIOCA5	I/O	TGRA_5 input capture input/output compare output/PWM output pin
	TIOCB5	I/O	TGRB_5 input capture input/output compare output/PWM output pin

10.3 Register Descriptions

The TPU has the following registers. To distinguish registers in each channel, an underscore and the channel number are added as a suffix to the register name; TCR for channel 0 is expressed as TCR_0.

- Timer control register_0 (TCR_0)
- Timer mode register_0 (TMDR_0)
- Timer I/O control register H_0 (TIORH_0)
- Timer I/O control register L_0 (TIORL_0)
- Timer interrupt enable register_0 (TIER_0)
- Timer status register_0 (TSR_0)
- Timer counter_0 (TCNT_0)
- Timer general register A_0 (TGRA_0)
- Timer general register B_0 (TGRB_0)
- Timer general register C_0 (TGRC_0)
- Timer general register D_0 (TGRD_0)
- Timer control register_1 (TCR_1)
- Timer mode register_1 (TMDR_1)
- Timer I/O control register_1 (TIOR_1)
- Timer interrupt enable register_1 (TIER_1)
- Timer status register_1 (TSR_1)
- Timer counter_1 (TCNT_1)
- Timer general register A_1 (TGRA_1)
- Timer general register B_1 (TGRB_1)
- Timer control register_2 (TCR_2)
- Timer mode register_2 (TMDR_2)
- Timer I/O control register_2 (TIOR_2)
- Timer interrupt enable register_2 (TIER_2)
- Timer status register_2 (TSR_2)
- Timer counter_2 (TCNT_2)
- Timer general register A_2 (TGRA_2)
- Timer general register B_2 (TGRB_2)
- Timer control register_3 (TCR_3)
- Timer mode register_3 (TMDR_3)
- Timer I/O control register H_3 (TIORH_3)

- Timer I/O control register L_3 (TIORL_3)
- Timer interrupt enable register_3 (TIER_3)
- Timer status register_3 (TSR_3)
- Timer counter_3 (TCNT_3)
- Timer general register A_3 (TGRA_3)
- Timer general register B_3 (TGRB_3)
- Timer general register C_3 (TGRC_3)
- Timer general register D_3 (TGRD_3)
- Timer control register_4 (TCR_4)
- Timer mode register_4 (TMDR_4)
- Timer I/O control register _4 (TIOR_4)
- Timer interrupt enable register_4 (TIER_4)
- Timer status register_4 (TSR_4)
- Timer counter_4 (TCNT_4)
- Timer general register A_4 (TGRA_4)
- Timer general register B_4 (TGRB_4)
- Timer control register_5 (TCR_5)
- Timer mode register_5 (TMDR_5)
- Timer I/O control register_5 (TIOR_5)
- Timer interrupt enable register_5 (TIER_5)
- Timer status register_5 (TSR_5)
- Timer counter_5 (TCNT_5)
- Timer general register A_5 (TGRA_5)
- Timer general register B_5 (TGRB_5)

Common Registers

- Timer start register (TSTR)
- Timer synchro register (TSYR)

10.3.1 Timer Control Register (TCR)

The TCR registers are 8-bit readable/writable registers that control the TCNT operation for each channel. The TPU has a total of six TCR registers, one for each channel (channels 5 to 0). TCR register settings should be conducted only when TCNT operation is stopped.

Bit	Bit Name	Initial value	R/W	Description
7	CCLR2	0	R/W	Counter Clear 2 to 0
6	CCLR1	0	R/W	These bits select the TCNT counter clearing source. See tables 10.3 and 10.4 for details.
5	CCLR0	0	R/W	
4	CKEG1	0	R/W	Clock Edge 1 and 0
3	CKEG0	0	R/W	<p>These bits select the input clock edge. When the input clock is counted using both edges, the input clock period is halved (e.g. $\phi/4$ both edges = $\phi/2$ rising edge). If phase counting mode is used on channels 1, 2, 4, and 5, this setting is ignored and the phase counting mode setting has priority. Internal clock edge selection is valid when the input clock is $\phi/4$ or slower. This setting is ignored if the input clock is $\phi/1$, or when overflow/underflow of another channel is selected.</p> <p>00: Count at rising edge 01: Count at falling edge 1x: Count at both edges</p> <p>Legend: x: Don't care</p>
2	TPSC2	0	R/W	Time Prescaler 2 to 0
1	TPSC1	0	R/W	These bits select the TCNT counter clock. The clock source can be selected independently for each channel. See tables 10.5 to 10.10 for details.
0	TPSC0	0	R/W	

Table 10.3 CCLR2 to CCLR0 (Channels 0 and 3)

Channel	Bit 7 CCLR2	Bit 6 CCLR1	Bit 5 CCLR0	Description
0, 3	0	0	0	TCNT clearing disabled
			1	TCNT cleared by TGRA compare match/input capture
			1	TCNT cleared by counter clearing for another channel performing synchronous clearing/ synchronous operation* ¹
	1	0	0	TCNT clearing disabled
			1	TCNT cleared by TGRC compare match/input capture* ²
			1	TCNT cleared by counter clearing for another channel performing synchronous clearing/ synchronous operation* ¹

- Notes: 1. Synchronous operation is set by setting the SYNC bit in TSYR to 1.
 2. When TGRC or TGRD is used as a buffer register, TCNT is not cleared because the buffer register setting has priority, and compare match/input capture does not occur.

Table 10.4 CCLR2 to CCLR0 (Channels 1, 2, 4, and 5)

Channel	Bit 7 Reserved* ²	Bit 6 CCLR1	Bit 5 CCLR0	Description
1, 2, 4, 5	0	0	0	TCNT clearing disabled
			1	TCNT cleared by TGRA compare match/input capture
			1	TCNT cleared by counter clearing for another channel performing synchronous clearing/ synchronous operation* ¹

- Notes: 1. Synchronous operation is selected by setting the SYNC bit in TSYR to 1.
 2. Bit 7 is reserved in channels 1, 2, 4, and 5. It is always read as 0 and cannot be modified.

Table 10.5 TPSC2 to TPSC0 (Channel 0)

Channel	Bit 2 TPSC2	Bit 1 TPSC1	Bit 0 TPSC0	Description
0	0	0	0	Internal clock: counts on $\phi/1$
			1	Internal clock: counts on $\phi/4$
		1	0	Internal clock: counts on $\phi/16$
			1	Internal clock: counts on $\phi/64$
	1	0	0	External clock: counts on TCLKA pin input
			1	External clock: counts on TCLKB pin input
		1	0	External clock: counts on TCLKC pin input
			1	External clock: counts on TCLKD pin input

Table 10.6 TPSC2 to TPSC0 (Channel 1)

Channel	Bit 2 TPSC2	Bit 1 TPSC1	Bit 0 TPSC0	Description
1	0	0	0	Internal clock: counts on $\phi/1$
			1	Internal clock: counts on $\phi/4$
		1	0	Internal clock: counts on $\phi/16$
			1	Internal clock: counts on $\phi/64$
	1	0	0	External clock: counts on TCLKA pin input
			1	External clock: counts on TCLKB pin input
		1	0	Internal clock: counts on $\phi/256$
			1	Counts on TCNT2 overflow/underflow

Note: This setting is ignored when channel 1 is in phase counting mode.

Table 10.7 TPSC2 to TPSC0 (Channel 2)

Channel	Bit 2 TPSC2	Bit 1 TPSC1	Bit 0 TPSC0	Description
2	0	0	0	Internal clock: counts on $\phi/1$
			1	Internal clock: counts on $\phi/4$
		1	0	Internal clock: counts on $\phi/16$
			1	Internal clock: counts on $\phi/64$
	1	0	0	External clock: counts on TCLKA pin input
			1	External clock: counts on TCLKB pin input
		1	0	External clock: counts on TCLKC pin input
			1	Internal clock: counts on $\phi/1024$

Note: This setting is ignored when channel 2 is in phase counting mode.

Table 10.8 TPSC2 to TPSC0 (Channel 3)

Channel	Bit 2 TPSC2	Bit 1 TPSC1	Bit 0 TPSC0	Description
3	0	0	0	Internal clock: counts on $\phi/1$
			1	Internal clock: counts on $\phi/4$
		1	0	Internal clock: counts on $\phi/16$
			1	Internal clock: counts on $\phi/64$
	1	0	0	External clock: counts on TCLKA pin input
			1	Internal clock: counts on $\phi/1024$
		1	0	Internal clock: counts on $\phi/256$
			1	Internal clock: counts on $\phi/4096$

Table 10.9 TPSC2 to TPSC0 (Channel 4)

Channel	Bit 2 TPSC2	Bit 1 TPSC1	Bit 0 TPSC0	Description
4	0	0	0	Internal clock: counts on $\phi/1$
			1	Internal clock: counts on $\phi/4$
			0	Internal clock: counts on $\phi/16$
			1	Internal clock: counts on $\phi/64$
	1	0	0	External clock: counts on TCLKA pin input
			1	External clock: counts on TCLKC pin input
			0	Internal clock: counts on $\phi/1024$
			1	Counts on TCNT5 overflow/underflow

Note: This setting is ignored when channel 4 is in phase counting mode.

Table 10.10 TPSC2 to TPSC0 (Channel 5)

Channel	Bit 2 TPSC2	Bit 1 TPSC1	Bit 0 TPSC0	Description
5	0	0	0	Internal clock: counts on $\phi/1$
			1	Internal clock: counts on $\phi/4$
			0	Internal clock: counts on $\phi/16$
			1	Internal clock: counts on $\phi/64$
	1	0	0	External clock: counts on TCLKA pin input
			1	External clock: counts on TCLKC pin input
			0	Internal clock: counts on $\phi/256$
			1	External clock: counts on TCLKD pin input

Note: This setting is ignored when channel 5 is in phase counting mode.

10.3.2 Timer Mode Register (TMDR)

The TMDR registers are 8-bit readable/writable registers that are used to set the operating mode of each channel. The TPU has six TMDR registers, one for each channel. TMDR register settings should be changed only when TCNT operation is stopped.

Bit	Bit Name	Initial value	R/W	Description
7, 6	—	All 1	—	Reserved These bits are always read as 1 and cannot be modified.
5	BFB	0	R/W	Buffer Operation B Specifies whether TGRB is to operate in the normal way, or TGRB and TGRD are to be used together for buffer operation. When TGRD is used as a buffer register, TGRD input capture/output compare is not generated. In channels 1, 2, 4, and 5, which have no TGRD, bit 5 is reserved. It is always read as 0 and cannot be modified. 0: TGRB operates normally 1: TGRB and TGRD used together for buffer operation
4	BFA	0	R/W	Buffer Operation A Specifies whether TGRA is to operate in the normal way, or TGRA and TGRC are to be used together for buffer operation. When TGRC is used as a buffer register, TGRC input capture/output compare is not generated. In channels 1, 2, 4, and 5, which have no TGRC, bit 4 is reserved. It is always read as 0 and cannot be modified. 0: TGRA operates normally 1: TGRA and TGRC used together for buffer operation
3	MD3	0	R/W	Modes 3 to 0
2	MD2	0	R/W	These bits are used to set the timer operating mode.
1	MD1	0	R/W	
0	MD0	0	R/W	

MD3 is a reserved bit. In a write, it should always be written with 0. See table 10.11 for details.

Table 10.11 MD3 to MD0

Bit 3 MD3*1	Bit 2 MD2*2	Bit 1 MD1	Bit 0 MD0	Description
0	0	0	0	Normal operation
			1	Reserved
		1	0	PWM mode 1
			1	PWM mode 2
	1	0	0	Phase counting mode 1
			1	Phase counting mode 2
		1	0	Phase counting mode 3
			1	Phase counting mode 4
1	×	×	×	—

Legend:

×: Don't care

- Notes:
1. MD3 is a reserved bit. In a write, it should always be written with 0.
 2. Phase counting mode cannot be set for channels 0 and 3. In this case, 0 should always be written to MD2.

10.3.3 Timer I/O Control Register (TIOR)

The TIOR registers are 8-bit readable/writable registers that control the TGR registers. The TPU has eight TIOR registers, two each for channels 0 and 3, and one each for channels 1, 2, 4, and 5.

Care is required as TIOR is affected by the TMDR setting. The initial output specified by TIOR is valid when the counter is stopped (the CST bit in TSTR is cleared to 0). Note also that, in PWM mode 2, the output at the point at which the counter is cleared to 0 is specified.

When TGRC or TGRD is designated for buffer operation, this setting is invalid and the register operates as a buffer register.

- TIORH_5, TIOR_4, TIOR_3, TIORH_2, TIOR_1, TIOR_0

Bit	Bit Name	Initial value	R/W	Description
7	IOB3	0	R/W	I/O Control B3 to B0
6	IOB2	0	R/W	Specify the function of TGRB.
5	IOB1	0	R/W	
4	IOB0	0	R/W	
3	IOA3	0	R/W	
2	IOA2	0	R/W	Specify the function of TGRA.
1	IOA1	0	R/W	
0	IOA0	0	R/W	

- TIORL_3, TIORL_0

Bit	Bit Name	Initial value	R/W	Description
7	IOD3	0	R/W	I/O Control D3 to D0
6	IOD2	0	R/W	Specify the function of TGRD.
5	IOD1	0	R/W	
4	IOD0	0	R/W	
3	IOC3	0	R/W	
2	IOC2	0	R/W	Specify the function of TGRC.
1	IOC1	0	R/W	
0	IOC0	0	R/W	

Table 10.12 TIORH_0 (Channel 0)

Bit 7 IOB3	Bit 6 IOB2	Bit 5 IOB1	Bit 4 IOB0	Description		
				TGRB_0 Function	TIOCB0 Pin Function	
0	0	0	0	Output compare register	Output disabled	
			1		Initial output is 0 0 output at compare match	
			1		Initial output is 0 1 output at compare match	
		1	0		Initial output is 0 Toggle output at compare match	
			1		Output disabled	
			1		Initial output is 1 0 output at compare match	
	1	0	0	Input capture register	Initial output is 1 1 output at compare match	
			1		Initial output is 1 Toggle output at compare match	
			1		Capture input source is the TIOCB0 pin Input capture at rising edge	
		1	0		0	Capture input source is the TIOCB0 pin Input capture at falling edge
					1	Capture input source is the TIOCB0 pin Input capture at both edges
			×		×	Capture input source is channel 1/count clock Input capture at TCNT_1 count-up/count-down*

Legend:

×: Don't care

Note: * When bits TPSC2 to TPSC0 in TCR_1 are set to B'000 and $\phi/1$ is used as the TCNT_1 count clock, this setting is invalid and input capture is not generated.

Table 10.13 TIORL_0 (Channel 0)

Bit 7 IOD3	Bit 6 IOD2	Bit 5 IOD1	Bit 4 IOD0	Description	
				TGRD_0 Function	TIOCD0 Pin Function
0	0	0	0	Output compare register ^{*2}	Output disabled
			1		Initial output is 0 0 output at compare match
		1	0		Initial output is 0 1 output at compare match
			1		Initial output is 0 Toggle output at compare match
	1	0	0	Input capture register ^{*2}	Output disabled
			1		Initial output is 1 0 output at compare match
		1	0		Initial output is 1 1 output at compare match
			1		Initial output is 1 Toggle output at compare match
1	0	0	Input capture register ^{*2}	Capture input source is the TIOCD0 pin Input capture at rising edge	
		1		Capture input source is the TIOCD0 pin Input capture at falling edge	
	1	×		Capture input source is the TIOCD0 pin Input capture at both edges	
		×		Capture input source is channel 1/count clock Input capture at TCNT_1 count-up/count-down ^{*1}	

Legend:

×: Don't care

- Notes:
1. When bits TPSC2 to TPSC0 in TCR_1 are set to B'000 and $\phi/1$ is used as the TCNT_1 count clock, this setting is invalid and input capture is not generated.
 2. When the BFB bit in TMDR_0 is set to 1 and TGRD_0 is used as a buffer register, this setting is invalid and input capture/output compare is not generated.

Table 10.14 TIOR_1 (Channel 1)

Bit 7 IOB3	Bit 6 IOB2	Bit 5 IOB1	Bit 4 IOB0	Description		
				TGRB_1 Function	TIOCB1 Pin Function	
0	0	0	0	Output compare register	Output disabled	
			1		Initial output is 0 0 output at compare match	
			1		Initial output is 0 1 output at compare match	
		1	0		Initial output is 0 Toggle output at compare match	
			1		Output disabled	
			1		Initial output is 1 0 output at compare match	
	1	0	0	Input capture register	Initial output is 1 1 output at compare match	
			1		Initial output is 1 Toggle output at compare match	
			1		Capture input source is the TIOCB1 pin Input capture at rising edge	
		1	×		0	Capture input source is the TIOCB1 pin Input capture at falling edge
					1	Capture input source is the TIOCB1 pin Input capture at both edges
			×		×	TGRC_0 compare match/ input capture Input capture at generation of TGRC_0 compare match/input capture

Legend:

×: Don't care

Table 10.15 TIOR_2 (Channel 2)

Bit 7 IOB3	Bit 6 IOB2	Bit 5 IOB1	Bit 4 IOB0	Description		
				TGRB_2 Function	TIOCB2 Pin Function	
0	0	0	0	Output compare register	Output disabled	
			1		Initial output is 0 0 output at compare match	
			0		Initial output is 0 1 output at compare match	
		1	0		Initial output is 0 Toggle output at compare match	
			1		Output disabled	
			0		Initial output is 1 0 output at compare match	
	1	0	0	Input capture register	Initial output is 1 1 output at compare match	
			1		Initial output is 1 Toggle output at compare match	
			0		Capture input source is the TIOCB2 pin Input capture at rising edge	
		1	0		0	Capture input source is the TIOCB2 pin Input capture at falling edge
					1	Capture input source is the TIOCB2 pin Input capture at both edges
			×		×	

Legend:

×: Don't care

Table 10.16 TIORH_3 (Channel 3)

Bit 7 IOB3	Bit 6 IOB2	Bit 5 IOB1	Bit 4 IOB0	Description	
				TGRB_3 Function	TIOCB3 Pin Function
0	0	0	0	Output compare register	Output disabled
			1		Initial output is 0 0 output at compare match
			1		Initial output is 0 1 output at compare match
		1	0		Initial output is 0 Toggle output at compare match
			1		Output disabled
			1		Initial output is 1 0 output at compare match
	1	0	0	Input capture register	Initial output is 1 1 output at compare match
			1		Initial output is 1 Toggle output at compare match
			1		Initial output is 1 Toggle output at compare match
		1	0		Capture input source is the TIOCB3 pin Input capture at rising edge
			1		Capture input source is the TIOCB3 pin Input capture at falling edge
			×		Capture input source is the TIOCB3 pin Input capture at both edges
1	×	×		Capture input source is channel 4/count clock Input capture at TCNT_4 count-up/count-down*	

Legend:

×: Don't care

Note: * When bits TPSC2 to TPSC0 in TCR_4 are set to B'000 and $\phi/1$ is used as the TCNT_4 count clock, this setting is invalid and input capture is not generated.

Table 10.17 TIORL_3 (Channel 3)

Bit 7 IOD3	Bit 6 IOD2	Bit 5 IOD1	Bit 4 IOD0	Description	
				TGRD_3 Function	TIOCD3 Pin Function
0	0	0	0	Output compare register*2	Output disabled
			1		Initial output is 0
					0 output at compare match
		1	0		Initial output is 0
					1 output at compare match
			1		Initial output is 0
	1	0	0		Toggle output at compare match
			1	Output disabled	
				Initial output is 1	
		1	0		0 output at compare match
				Initial output is 1	
			0	1 output at compare match	
1	0	0		Initial output is 1	
		1	Toggle output at compare match		
			Initial output is 1		
	1	0		0 output at compare match	
			Initial output is 1		
		0	Toggle output at compare match		
1	0	0	Input capture register*2	Capture input source is the TIOCD3 pin	
				Input capture at rising edge	
		1		Capture input source is the TIOCD3 pin	
	1	×		Input capture at falling edge	
				Capture input source is the TIOCD3 pin	
				Input capture at both edges	
1	×	×		Capture input source is channel 4/count clock	
				Input capture at TCNT_4 count-up/count-down*1	

Legend:

×: Don't care

- Notes:
1. When bits TPSC2 to TPSC0 in TCR_4 are set to B'000 and $\phi/1$ is used as the TCNT_4 count clock, this setting is invalid and input capture is not generated.
 2. When the BFB bit in TMDR_3 is set to 1 and TGRD_3 is used as a buffer register, this setting is invalid and input capture/output compare is not generated.

Table 10.18 TIOR_4 (Channel 4)

Bit 7 IOB3	Bit 6 IOB2	Bit 5 IOB1	Bit 4 IOB0	Description	
				TGRB_4 Function	TIOCB4 Pin Function
0	0	0	0	Output compare register	Output disabled
			1		Initial output is 0 0 output at compare match
			1		Initial output is 0 1 output at compare match
		1	0		Initial output is 0 Toggle output at compare match
			1		Output disabled
			1		Initial output is 1 0 output at compare match
	1	0	0	Input capture register	Initial output is 1 1 output at compare match
			1		Initial output is 1 Toggle output at compare match
			1		Initial output is 1 Toggle output at compare match
		1	0		Capture input source is the TIOCB4 pin Input capture at rising edge
			1		Capture input source is the TIOCB4 pin Input capture at falling edge
			×		Capture input source is the TIOCB4 pin Input capture at both edges
1	×	×		Capture input source is TGRC_3 compare match/input capture	
				Input capture at generation of TGRC_3 compare match/input capture	

Legend:

×: Don't care

Table 10.19 TIOR_5 (Channel 5)

Bit 7 IOB3	Bit 6 IOB2	Bit 5 IOB1	Bit 4 IOB0	Description		
				TGRB_5 Function	TIOCB5 Pin Function	
0	0	0	0	Output compare register	Output disabled	
			1		Initial output is 0 0 output at compare match	
			0		Initial output is 0 1 output at compare match	
		1	0		Initial output is 0 Toggle output at compare match	
			1		Output disabled	
			0		Initial output is 1 0 output at compare match	
	1	0	0	Input capture register	Initial output is 1 1 output at compare match	
			1		Initial output is 1 Toggle output at compare match	
			0		Capture input source is the TIOCB5 pin Input capture at rising edge	
		1	0		1	Capture input source is the TIOCB5 pin Input capture at falling edge
					×	Capture input source is the TIOCB5 pin Input capture at both edges
			1		×	

Legend:

×: Don't care

Table 10.20 TIORH_0 (Channel 0)

Bit 3 IOA3	Bit 2 IOA2	Bit 1 IOA1	Bit 0 IOA0	Description		
				TGRA_0 Function	TIOCA0 Pin Function	
0	0	0	0	Output compare register	Output disabled	
			1		Initial output is 0 0 output at compare match	
		1	0		Initial output is 0 1 output at compare match	
			1		Initial output is 0 Toggle output at compare match	
	1	0	0	0	Output disabled	
				1	Initial output is 1 0 output at compare match	
			1	0	Initial output is 1 1 output at compare match	
				1	Initial output is 1 Toggle output at compare match	
		0	0	0	Input capture register	Capture input source is the TIOCA0 pin Input capture at rising edge
				1		Capture input source is the TIOCA0 pin Input capture at falling edge
			1	×		Capture input source is the TIOCA0 pin Input capture at both edges
				1		×

Legend:

x: Don't care

Table 10.21 TIORL_0 (Channel 0)

Bit 3 IOC3	Bit 2 IOC2	Bit 1 IOC1	Bit 0 IOC0	Description	
				TGRC_0 Function	TIOCC0 Pin Function
0	0	0	0	Output compare register*	Output disabled
			1		Initial output is 0 0 output at compare match
			0		Initial output is 0 1 output at compare match
		1	0		Initial output is 0 Toggle output at compare match
			1		Output disabled
			0		Initial output is 1 0 output at compare match
	1	0	0	Input capture register*	Initial output is 1 1 output at compare match
			1		Initial output is 1 Toggle output at compare match
			0		Capture input source is the TIOCC0 pin Input capture at rising edge
		1	0		Capture input source is the TIOCC0 pin Input capture at falling edge
			1		Capture input source is the TIOCC0 pin Input capture at both edges
			×		Capture input source is channel 1/count clock Input capture at TCNT_1 count-up/count-down

Legend:

×: Don't care

Note: * When the BFA bit in TMDR_0 is set to 1 and TGRC_0 is used as a buffer register, this setting is invalid and input capture/output compare is not generated.

Table 10.22 TIOR_1 (Channel 1)

Bit 3 IOA3	Bit 2 IOA2	Bit 1 IOA1	Bit 0 IOA0	Description		
				TGRA_1 Function	TIOCA1 Pin Function	
0	0	0	0	Output compare register	Output disabled	
			1		Initial output is 0 0 output at compare match	
		1	0		Initial output is 0 1 output at compare match	
			1		Initial output is 0 Toggle output at compare match	
	1	0	0	0	Output disabled	
				1	Initial output is 1 0 output at compare match	
			1	0	Initial output is 1 1 output at compare match	
				1	Initial output is 1 Toggle output at compare match	
		0	0	0	Input capture register	Capture input source is the TIOCA1 pin Input capture at rising edge
				1		Capture input source is the TIOCA1 pin Input capture at falling edge
			1	×		Capture input source is the TIOCA1 pin Input capture at both edges
				×		Capture input source is TGRA_0 compare match/input capture Input capture at generation of channel 0/TGRA_0 compare match/input capture

Legend:

×: Don't care

Table 10.23 TIOR_2 (Channel 2)

Bit 3 IOA3	Bit 2 IOA2	Bit 1 IOA1	Bit 0 IOA0	Description	
				TGRA_2 Function	TIOCA2 Pin Function
0	0	0	0	Output compare register	Output disabled
			1		Initial output is 0 0 output at compare match
		1	0		Initial output is 0 1 output at compare match
			1		Initial output is 0 Toggle output at compare match
	1	0	0		Output disabled
			1		Initial output is 1 0 output at compare match
		1	0		Initial output is 1 1 output at compare match
			1		Initial output is 1 Toggle output at compare match
1	×	0	0	Input capture register	Capture input source is the TIOCA2 pin Input capture at rising edge
			1		Capture input source is the TIOCA2 pin Input capture at falling edge
	1	×	Capture input source is the TIOCA2 pin Input capture at both edges		

Legend:

×: Don't care

Table 10.24 TIORH_3 (Channel 3)

Bit 3 IOA3	Bit 2 IOA2	Bit 1 IOA1	Bit 0 IOA0	Description		
				TGRA_3 Function	TIOCA3 Pin Function	
0	0	0	0	Output compare register	Output disabled	
			1		Initial output is 0 0 output at compare match	
		1	0		Initial output is 0 1 output at compare match	
			1		Initial output is 0 Toggle output at compare match	
	1	0	0	0	Output disabled	
				1	Initial output is 1 0 output at compare match	
			1	0	Initial output is 1 1 output at compare match	
				1	Initial output is 1 Toggle output at compare match	
		0	0	0	Input capture register	Capture input source is the TIOCA3 pin Input capture at rising edge
				1		Capture input source is the TIOCA3 pin Input capture at falling edge
			1	×		Capture input source is the TIOCA3 pin Input capture at both edges
				1		×

Legend:

x: Don't care

Table 10.25 TIORL_3 (Channel 3)

Bit 3 IOC3	Bit 2 IOC2	Bit 1 IOC1	Bit 0 IOC0	Description	
				TGRC_3 Function	TIOCC3 Pin Function
0	0	0	0	Output compare register*	Output disabled
			1		Initial output is 0 0 output at compare match
			0		Initial output is 0 1 output at compare match
		1	0		Initial output is 0 Toggle output at compare match
			1		Output disabled
			0		Initial output is 1 0 output at compare match
	1	0	0	Input capture register*	Initial output is 1 1 output at compare match
			1		Initial output is 1 Toggle output at compare match
			0		Capture input source is the TIOCC3 pin Input capture at rising edge
		1	0		Capture input source is the TIOCC3 pin Input capture at falling edge
			1		Capture input source is the TIOCC3 pin Input capture at both edges
			×		Capture input source is channel 4/count clock Input capture at TCNT_4 count-up/count-down

Legend:

×: Don't care

Note: * When the BFA bit in TMDR_3 is set to 1 and TGRC_3 is used as a buffer register, this setting is invalid and input capture/output compare is not generated.

Table 10.26 TIOR_4 (Channel 4)

Bit 3 IOA3	Bit 2 IOA2	Bit 1 IOA1	Bit 0 IOA0	Description		
				TGRA_4 Function	TIOCA4 Pin Function	
0	0	0	0	Output compare register	Output disabled	
			1		Initial output is 0 0 output at compare match	
		1	0		Initial output is 0 1 output at compare match	
			1		Initial output is 0 Toggle output at compare match	
		1	0		0	Output disabled
					1	Initial output is 1 0 output at compare match
	1		0	Initial output is 1 1 output at compare match		
			1	Initial output is 1 Toggle output at compare match		
	1	0	0	Input capture register	Capture input source is the TIOCA4 pin Input capture at rising edge	
					1	Capture input source is the TIOCA4 pin Input capture at falling edge
			1		×	Capture input source is the TIOCA4 pin Input capture at both edges
		1	×		×	Capture input source is TGRA_3 compare match/input capture
Input capture at generation of TGRA_3 compare match/input capture						

Legend:

×: Don't care

Table 10.27 TIOR_5 (Channel 5)

Bit 3 IOA3	Bit 2 IOA2	Bit 1 IOA1	Bit 0 IOA0	Description	
				TGRA_5 Function	TIOCA5 Pin Function
0	0	0	0	Output compare register	Output disabled
			1		Initial output is 0 0 output at compare match
		1	0		Initial output is 0 1 output at compare match
			1		Initial output is 0 Toggle output at compare match
	1	0	0		Output disabled
			1		Initial output is 1 0 output at compare match
		1	0		Initial output is 1 1 output at compare match
			1		Initial output is 1 Toggle output at compare match
1	×	0	0	Input capture register	Capture input source is the TIOCA5 pin Input capture at rising edge
			1		Capture input source is the TIOCA5 pin Input capture at falling edge
	1	×	0		Capture input source is the TIOCA5 pin Input capture at both edges
			1		

Legend:

×: Don't care

10.3.4 Timer Interrupt Enable Register (TIER)

The TIER registers are 8-bit readable/writable registers that control enabling or disabling of interrupt requests for each channel. The TPU has six TIER registers, one for each channel.

Bit	Bit Name	Initial value	R/W	Description
7	TTGE	0	R/W	<p>A/D Conversion Start Request Enable</p> <p>Enables or disables generation of A/D conversion start requests by TGRA input capture/compare match.</p> <p>0: A/D conversion start request generation disabled 1: A/D conversion start request generation enabled</p>
6	—	1	—	<p>Reserved</p> <p>This bit is always read as 1 and cannot be modified.</p>
5	TCIEU	0	R/W	<p>Underflow Interrupt Enable</p> <p>Enables or disables interrupt requests (TCIU) by the TCFU flag when the TCFU flag in TSR is set to 1 in channels 1, 2, 4, and 5.</p> <p>In channels 0 and 3, bit 5 is reserved. It is always read as 0 and cannot be modified.</p> <p>0: Interrupt requests (TCIU) by TCFU disabled 1: Interrupt requests (TCIU) by TCFU enabled</p>
4	TCIEV	0	R/W	<p>Overflow Interrupt Enable</p> <p>Enables or disables interrupt requests (TCIV) by the TCFV flag when the TCFV flag in TSR is set to 1.</p> <p>0: Interrupt requests (TCIV) by TCFV disabled 1: Interrupt requests (TCIV) by TCFV enabled</p>
3	TGIED	0	R/W	<p>TGR Interrupt Enable D</p> <p>Enables or disables interrupt requests (TGID) by the TGFD bit when the TGFD bit in TSR is set to 1 in channels 0 and 3.</p> <p>In channels 1, 2, 4, and 5, bit 3 is reserved. It is always read as 0 and cannot be modified.</p> <p>0: Interrupt requests (TGID) by TGFD bit disabled 1: Interrupt requests (TGID) by TGFD bit enabled</p>

Bit	Bit Name	Initial value	R/W	Description
2	TGIEC	0	R/W	<p>TGR Interrupt Enable C</p> <p>Enables or disables interrupt requests (TGIC) by the TGFC bit when the TGFC bit in TSR is set to 1 in channels 0 and 3.</p> <p>In channels 1, 2, 4, and 5, bit 2 is reserved. It is always read as 0 and cannot be modified.</p> <p>0: Interrupt requests (TGIC) by TGFC bit disabled 1: Interrupt requests (TGIC) by TGFC bit enabled</p>
1	TGIEB	0	R/W	<p>TGR Interrupt Enable B</p> <p>Enables or disables interrupt requests (TGIB) by the TGFB bit when the TGFB bit in TSR is set to 1.</p> <p>0: Interrupt requests (TGIB) by TGFB bit disabled 1: Interrupt requests (TGIB) by TGFB bit enabled</p>
0	TGIEA	0	R/W	<p>TGR Interrupt Enable A</p> <p>Enables or disables interrupt requests (TGIA) by the TGFA bit when the TGFA bit in TSR is set to 1.</p> <p>0: Interrupt requests (TGIA) by TGFA bit disabled 1: Interrupt requests (TGIA) by TGFA bit enabled</p>

10.3.5 Timer Status Register (TSR)

The TSR registers are 8-bit readable/writable registers that indicate the status of each channel. The TPU has six TSR registers, one for each channel.

Bit	Bit Name	Initial value	R/W	Description
7	TCFD	1	R	<p>Count Direction Flag</p> <p>Status flag that shows the direction in which TCNT counts in channels 1, 2, 4, and 5. In channels 0 and 3, bit 7 is reserved. It is always read as 1 and cannot be modified.</p> <p>0: TCNT counts down 1: TCNT counts up</p>
6	—	1	—	<p>Reserved</p> <p>This bit is always read as 1 and cannot be modified.</p>
5	TCFU	0	R/(W)	<p>Underflow Flag</p> <p>Status flag that indicates that TCNT underflow has occurred when channels 1, 2, 4, and 5 are set to phase counting mode. Only 0 can be written, for flag clearing. In channels 0 and 3, bit 5 is reserved. It is always read as 0 and cannot be modified.</p> <p>[Setting condition]</p> <ul style="list-style-type: none"> When the TCNT value underflows (changes from H'0000 to H'FFFF) <p>[Clearing condition]</p> <ul style="list-style-type: none"> When 0 is written to TCFU after reading TCFU = 1
4	TCFV	0	R/(W)	<p>Overflow Flag</p> <p>Status flag that indicates that TCNT overflow has occurred. Only 0 can be written, for flag clearing.</p> <p>[Setting condition]</p> <ul style="list-style-type: none"> When the TCNT value overflows (changes from H'FFFF to H'0000) <p>[Clearing condition]</p> <ul style="list-style-type: none"> When 0 is written to TCFV after reading TCFV = 1

Bit	Bit Name	Initial value	R/W	Description
3	TGFD	0	R/(W)	<p>Input Capture/Output Compare Flag D</p> <p>Status flag that indicates the occurrence of TGRD input capture or compare match in channels 0 and 3. Only 0 can be written, for flag clearing. In channels 1, 2, 4, and 5, bit 3 is reserved. It is always read as 0 and cannot be modified.</p> <p>[Setting conditions]</p> <ul style="list-style-type: none"> • When TCNT = TGRD and TGRD is functioning as output compare register • When TCNT value is transferred to TGRD by input capture signal and TGRD is functioning as input capture register <p>[Clearing conditions]</p> <ul style="list-style-type: none"> • When DTC is activated by TGID interrupt and the DISEL bit of MRB in DTC is 0 • When 0 is written to TGFD after reading TGFD = 1
2	TGFC	0	R/(W)	<p>Input Capture/Output Compare Flag C</p> <p>Status flag that indicates the occurrence of TGRC input capture or compare match in channels 0 and 3. Only 0 can be written, for flag clearing. In channels 1, 2, 4, and 5, bit 2 is reserved. It is always read as 0 and cannot be modified.</p> <p>[Setting conditions]</p> <ul style="list-style-type: none"> • When TCNT = TGRC and TGRC is functioning as output compare register • When TCNT value is transferred to TGRC by input capture signal and TGRC is functioning as input capture register <p>[Clearing conditions]</p> <ul style="list-style-type: none"> • When DTC is activated by TGIC interrupt and the DISEL bit of MRB in DTC is 0 • When 0 is written to TGFC after reading TGFC = 1

Bit	Bit Name	Initial value	R/W	Description
1	TGFB	0	R/(W)	<p>Input Capture/Output Compare Flag B</p> <p>Status flag that indicates the occurrence of TGRB input capture or compare match. Only 0 can be written, for flag clearing.</p> <p>[Setting conditions]</p> <ul style="list-style-type: none"> When TCNT = TGRB and TGRB is functioning as output compare register When TCNT value is transferred to TGRB by input capture signal and TGRB is functioning as input capture register <p>[Clearing conditions]</p> <ul style="list-style-type: none"> When DTC is activated by TGIB interrupt and the DISEL bit of MRB in DTC is 0 When 0 is written to TGFB after reading TGFB = 1
0	TGFA	0	R/(W)	<p>Input Capture/Output Compare Flag A</p> <p>Status flag that indicates the occurrence of TGRA input capture or compare match. Only 0 can be written, for flag clearing.</p> <p>[Setting conditions]</p> <ul style="list-style-type: none"> When TCNT = TGRA and TGRA is functioning as output compare register When TCNT value is transferred to TGRA by input capture signal and TGRA is functioning as input capture register <p>[Clearing conditions]</p> <ul style="list-style-type: none"> When DTC is activated by TGIA interrupt and the DISEL bit of MRB in DTC is 0 When 0 is written to TGFA after reading TGFA = 1

10.3.6 Timer Counter (TCNT)

The TCNT registers are 16-bit readable/writable counters. The TPU has six TCNT counters, one for each channel.

The TCNT counters are initialized to H'0000 by a reset, and in hardware standby mode.

The TCNT counters cannot be accessed in 8-bit units; they must always be accessed as a 16-bit unit.

10.3.7 Timer General Register (TGR)

The TGR registers are dual function 16-bit readable/writable registers, functioning as either output compare or input capture registers. The TPU has 16 TGR registers, four each for channels 0 and 3 and two each for channels 1, 2, 4, and 5. TGRC and TGRD for channels 0 and 3 can also be designated for operation as buffer registers. The TGR registers cannot be accessed in 8-bit units; they must always be accessed as a 16-bit unit. TGR buffer register combinations are TGRA–TGRC and TGRB–TGRD.

10.3.8 Timer Start Register (TSTR)

TSTR is an 8-bit readable/writable register that selects operation/stoppage for channels 0 to 5. When setting the operating mode in TMDR or setting the count clock in TCR, first stop the TCNT counter.

Bit	Bit Name	Initial value	R/W	Description
7, 6	—	All 0	—	Reserved The write value should always be 0.
5	CST5	0	R/W	Counter Start 5 to 0 (CST5 to CST0)
4	CST4	0	R/W	These bits select operation or stoppage for TCNT. If 0 is written to the CST bit during operation with the TIOC pin designated for output, the counter stops but the TIOC pin output compare output level is retained. If TIOR is written to when the CST bit is cleared to 0, the pin output level will be changed to the set initial output value. 0: TCNT_5 to TCNT_0 count operation is stopped 1: TCNT_5 to TCNT_0 performs count operation
3	CST3	0	R/W	
2	CST2	0	R/W	
1	CST1	0	R/W	
0	CST0	0	R/W	

10.3.9 Timer Synchro Register (TSYR)

TSYR is an 8-bit readable/writable register that selects independent operation or synchronous operation for the channel 0 to 5 TCNT counters. A channel performs synchronous operation when the corresponding bit in TSYR is set to 1.

Bit	Bit Name	Initial value	R/W	Description
7, 6	—	All 0	R/W	Reserved The write value should always be 0.
5	SYNC5	0	R/W	Timer Synchro 0 to 5
4	SYNC4	0	R/W	These bits are used to select whether operation is independent of or synchronized with other channels. When synchronous operation is selected, the TCNT synchronous presetting of multiple channels, and synchronous clearing by counter clearing on another channel, are possible. To set synchronous operation, the SYNC bits for at least two channels must be set to 1. To set synchronous clearing, in addition to the SYNC bit, the TCNT clearing source must also be set by means of bits CCLR0 to CCLR2 in TCR. 0: TCNT_0 to TCNT_5 operates independently (TCNT presetting/clearing is unrelated to other channels) 1: TCNT_0 to TCNT_5 performs synchronous operation TCNT synchronous presetting/synchronous clearing is possible
3	SYNC3	0	R/W	
2	SYNC2	0	R/W	
1	SYNC1	0	R/W	
0	SYNC0	0	R/W	

10.4 Operation

10.4.1 Basic Functions

Each channel has a TCNT and TGR register. TCNT performs up-counting, and is also capable of free-running operation, periodic counting, and external event counting.

Each TGR can be used as an input capture register or output compare register.

Counter Operation: When one of bits CST5 to CST0 is set to 1 in TSTR, the TCNT counter for the corresponding channel begins counting. TCNT can operate as a free-running counter, periodic counter, for example.

1. Example of count operation setting procedure

Figure 10.2 shows an example of the count operation setting procedure.

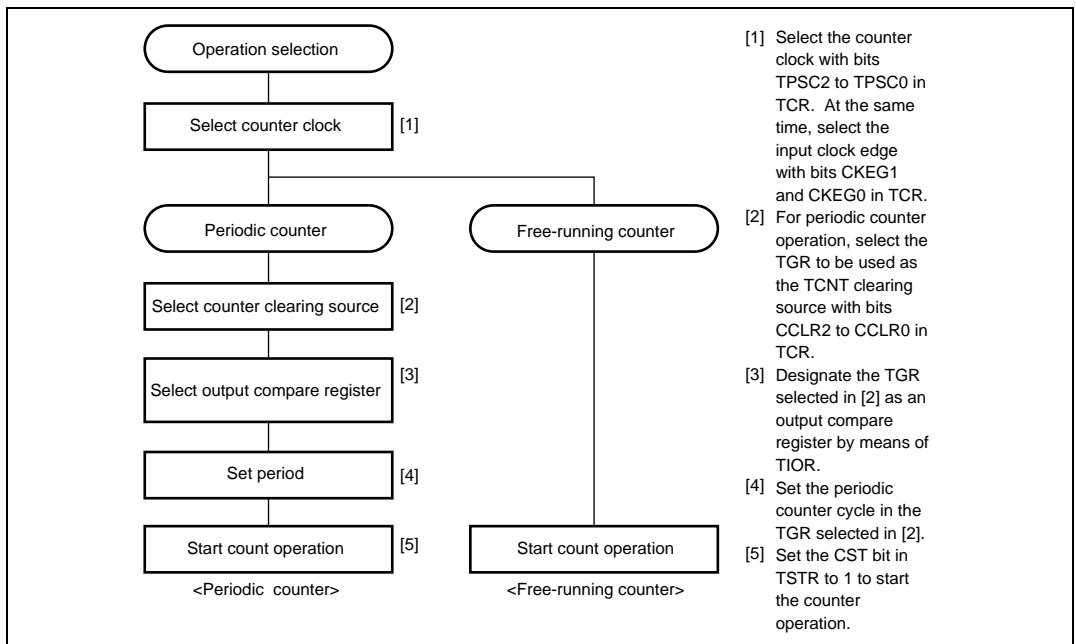

Figure 10.2 Example of Counter Operation Setting Procedure

2. Free-running count operation and periodic count operation

Immediately after a reset, the TPU's TCNT counters are all designated as free-running counters. When the relevant bit in TSTR is set to 1 the corresponding TCNT counter starts up-count operation as a free-running counter. When TCNT overflows (from H'FFFF to H'0000), the TCFV bit in TSR is set to 1. If the value of the corresponding TCIEV bit in TIER is 1 at this point, the TPU requests an interrupt. After overflow, TCNT starts counting up again from H'0000.

Figure 10.3 illustrates free-running counter operation.

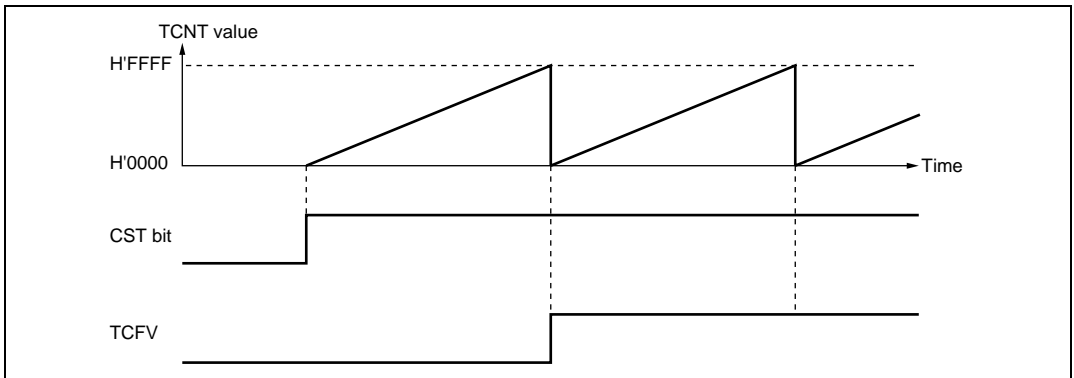

Figure 10.3 Free-Running Counter Operation

When compare match is selected as the TCNT clearing source, the TCNT counter for the relevant channel performs periodic count operation. The TGR register for setting the period is designated as an output compare register, and counter clearing by compare match is selected by means of bits CCLR2 to CCLR0 in TCR. After the settings have been made, TCNT starts up-count operation as a periodic counter when the corresponding bit in TSTR is set to 1. When the count value matches the value in TGR, the TGF bit in TSR is set to 1 and TCNT is cleared to H'0000.

If the value of the corresponding TGIE bit in TIER is 1 at this point, the TPU requests an interrupt. After a compare match, TCNT starts counting up again from H'0000.

Figure 10.4 illustrates periodic counter operation.

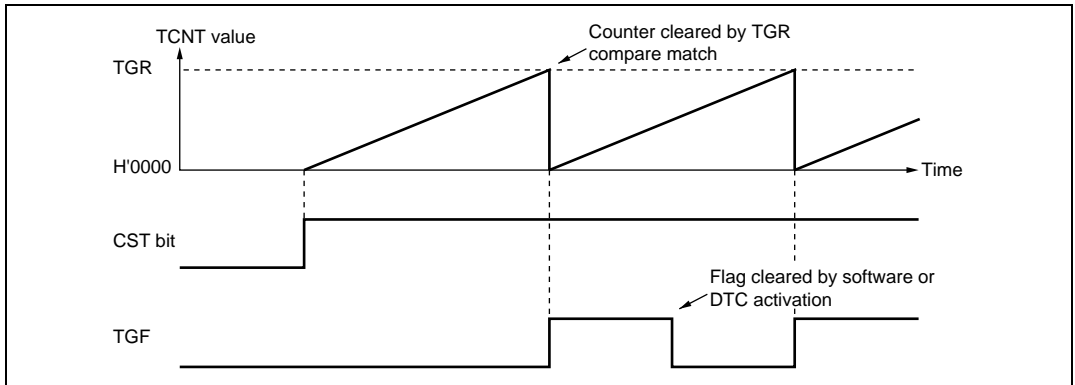

Figure 10.4 Periodic Counter Operation

Waveform Output by Compare Match: The TPU can perform 0, 1, or toggle output from the corresponding output pin using compare match.

1. Example of setting procedure for waveform output by compare match

Figure 10.5 shows an example of the setting procedure for waveform output by compare match.

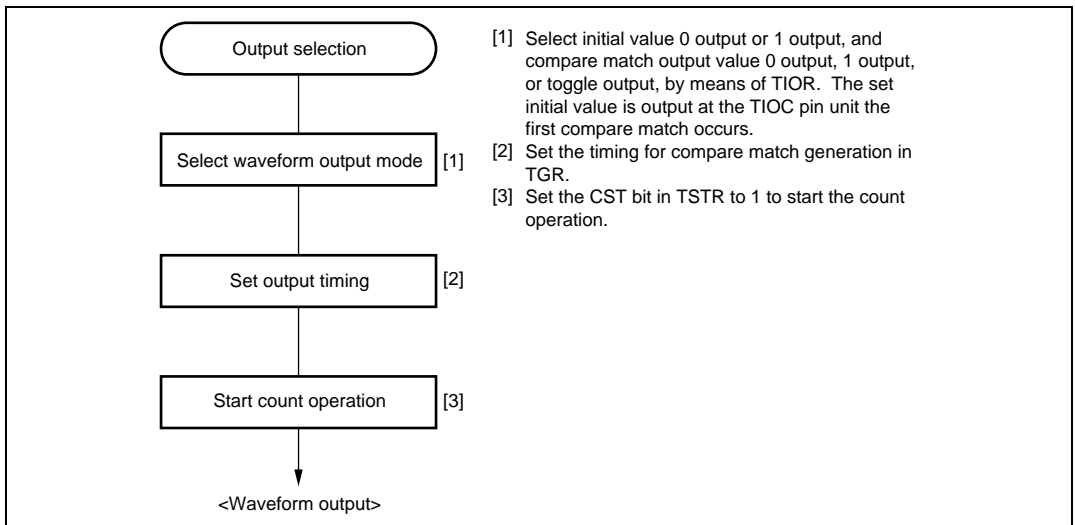

Figure 10.5 Example of Setting Procedure for Waveform Output by Compare Match

2. Examples of waveform output operation

Figure 10.6 shows an example of 0 output/1 output.

In this example TCNT has been designated as a free-running counter, and settings have been made such that 1 is output by compare match A, and 0 is output by compare match B. When the set level and the pin level coincide, the pin level does not change.

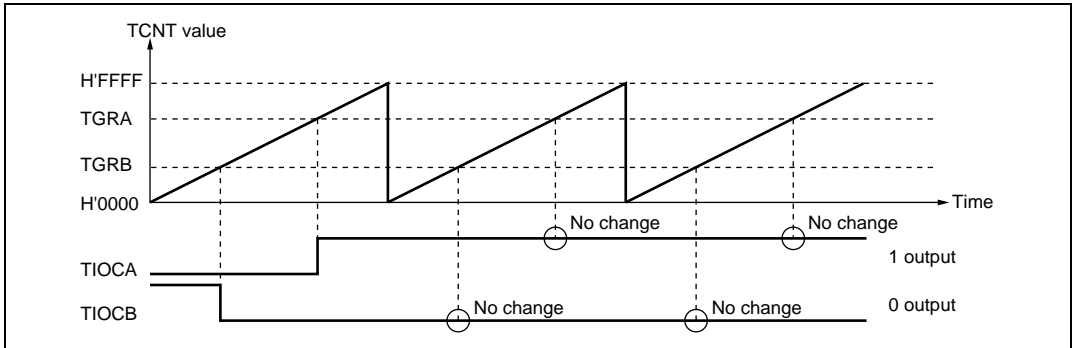

Figure 10.6 Example of 0 Output/1 Output Operation

Figure 10.7 shows an example of toggle output.

In this example, TCNT has been designated as a periodic counter (with counter clearing on compare match B), and settings have been made such that the output is toggled by both compare match A and compare match B.

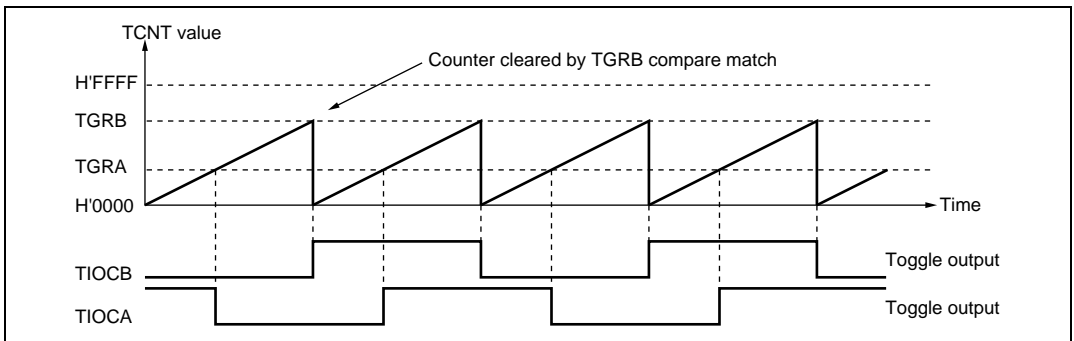

Figure 10.7 Example of Toggle Output Operation

Input Capture Function: The TCNT value can be transferred to TGR on detection of the TIOC pin input edge.

Rising edge, falling edge, or both edges can be selected as the detected edge. For channels 0, 1, 3, and 4, it is also possible to specify another channel's counter input clock or compare match signal as the input capture source.

Note: When another channel's counter input clock is used as the input capture input for channels 0 and 3, $\phi/1$ should not be selected as the counter input clock used for input capture input. Input capture will not be generated if $\phi/1$ is selected.

1. Example of input capture operation setting procedure

Figure 10.8 shows an example of the input capture operation setting procedure.

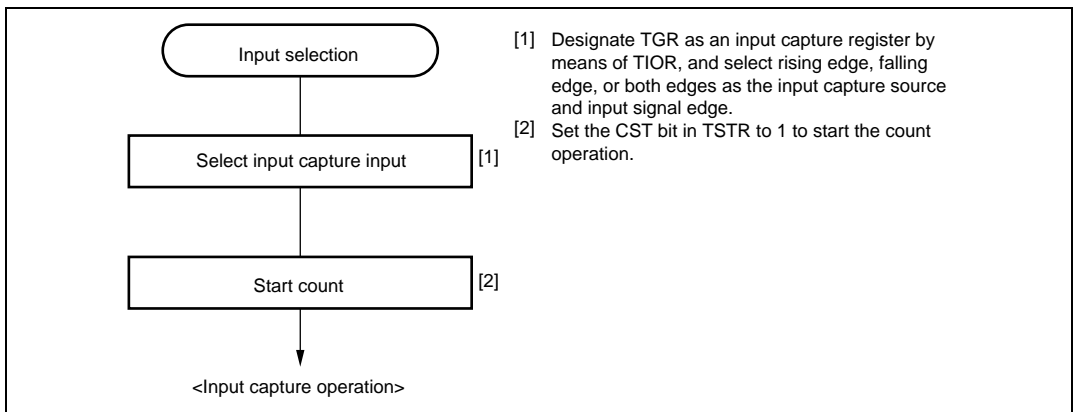

Figure 10.8 Example of Input Capture Operation Setting Procedure

2. Example of input capture operation

Figure 10.9 shows an example of input capture operation.

In this example both rising and falling edges have been selected as the TIOCA pin input capture input edge, the falling edge has been selected as the TIOCB pin input capture input edge, and counter clearing by TGRB input capture has been designated for TCNT.

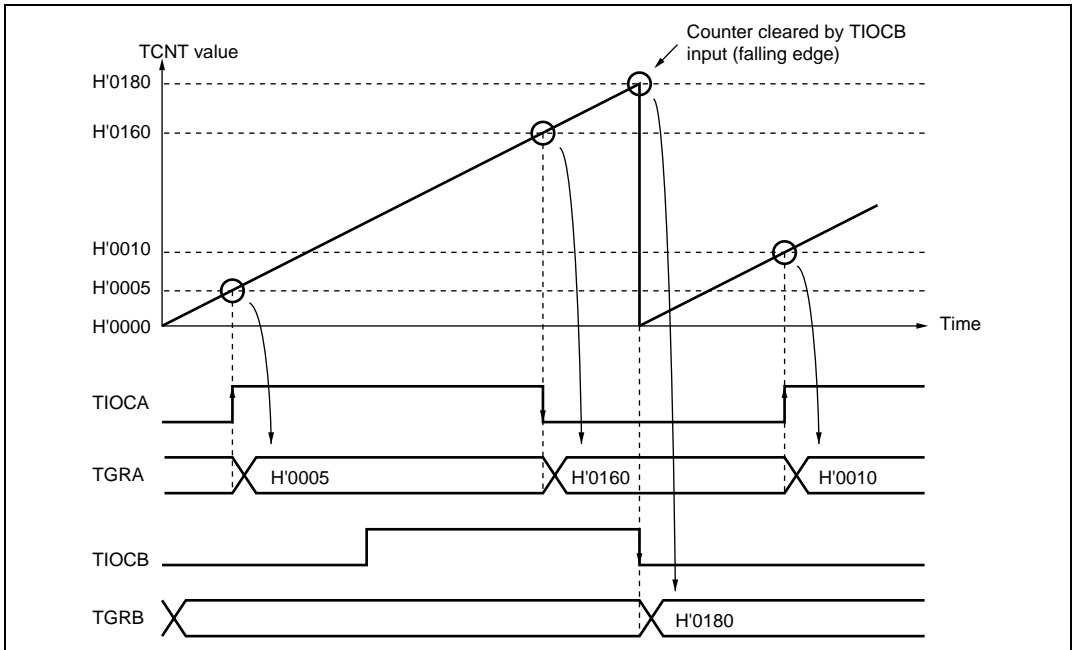

Figure 10.9 Example of Input Capture Operation

10.4.2 Synchronous Operation

In synchronous operation, the values in a number of TCNT counters can be rewritten simultaneously (synchronous presetting). Also, a number of TCNT counters can be cleared simultaneously by making the appropriate setting in TCR (synchronous clearing).

Synchronous operation enables TGR to be incremented with respect to a single time base.

Channels 0 to 5 can all be designated for synchronous operation.

Example of Synchronous Operation Setting Procedure: Figure 10.10 shows an example of the synchronous operation setting procedure.

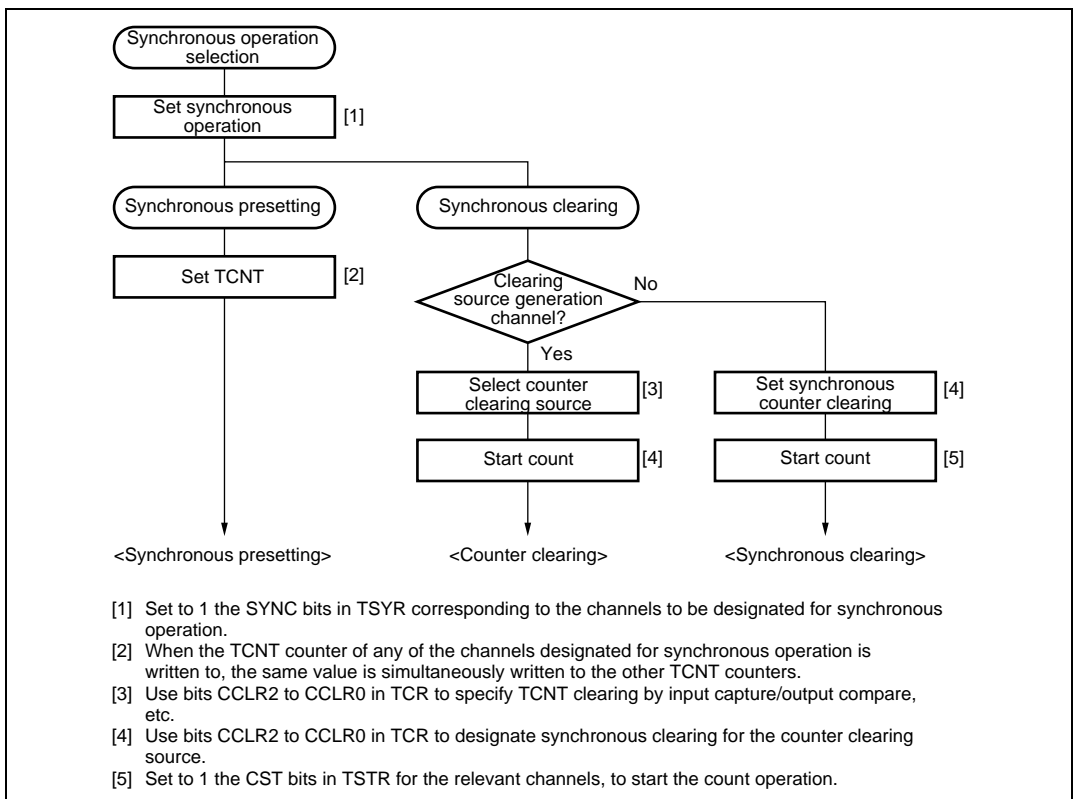

Figure 10.10 Example of Synchronous Operation Setting Procedure

Example of Synchronous Operation: Figure 10.11 shows an example of synchronous operation.

In this example, synchronous operation and PWM mode 1 have been designated for channels 0 to 2, TGRB_0 compare match has been set as the channel 0 counter clearing source, and synchronous clearing has been set for the channel 1 and 2 counter clearing sources.

Three-phase PWM waveforms are output from pins TIOCA0, TIOCA1, and TIOCA2. At this time, synchronous presetting, and synchronous clearing by TGRB_0 compare match, are performed for channel 0 to 2 TCNT counters, and the data set in TGRB_0 is used as the PWM cycle.

For details of PWM modes, see section 10.4.5, PWM Modes.

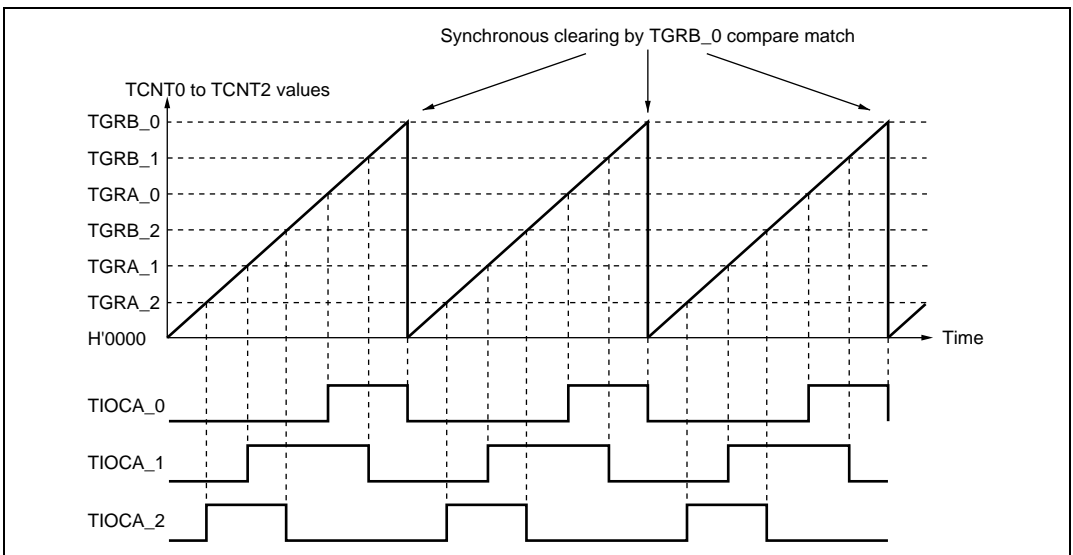

Figure 10.11 Example of Synchronous Operation

10.4.3 Buffer Operation

Buffer operation, provided for channels 0 and 3, enables TGRC and TGRD to be used as buffer registers.

Buffer operation differs depending on whether TGR has been designated as an input capture register or as a compare match register.

Table 10.28 shows the register combinations used in buffer operation.

Table 10.28 Register Combinations in Buffer Operation

Channel	Timer General Register	Buffer Register
0	TGRA_0	TGRC_0
	TGRB_0	TGRD_0
3	TGRA_3	TGRC_3
	TGRB_3	TGRD_3

- When TGR is an output compare register

When a compare match occurs, the value in the buffer register for the corresponding channel is transferred to the timer general register.

This operation is illustrated in figure 10.12.

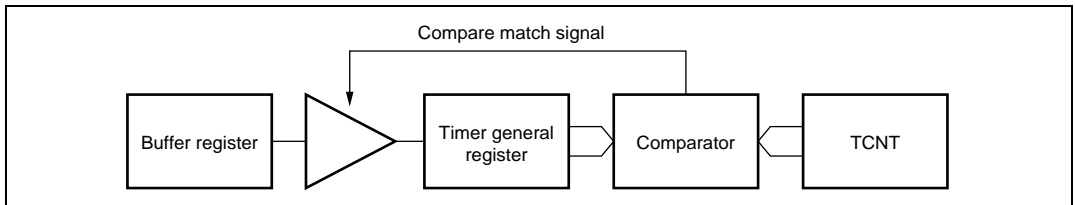
**Figure 10.12 Compare Match Buffer Operation**

- When TGR is an input capture register

When input capture occurs, the value in TCNT is transferred to TGR and the value previously held in the timer general register is transferred to the buffer register.

This operation is illustrated in figure 10.13.

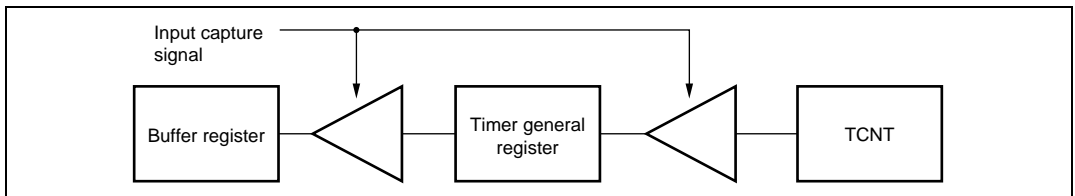
**Figure 10.13 Input Capture Buffer Operation**

Example of Buffer Operation Setting Procedure: Figure 10.14 shows an example of the buffer operation setting procedure.

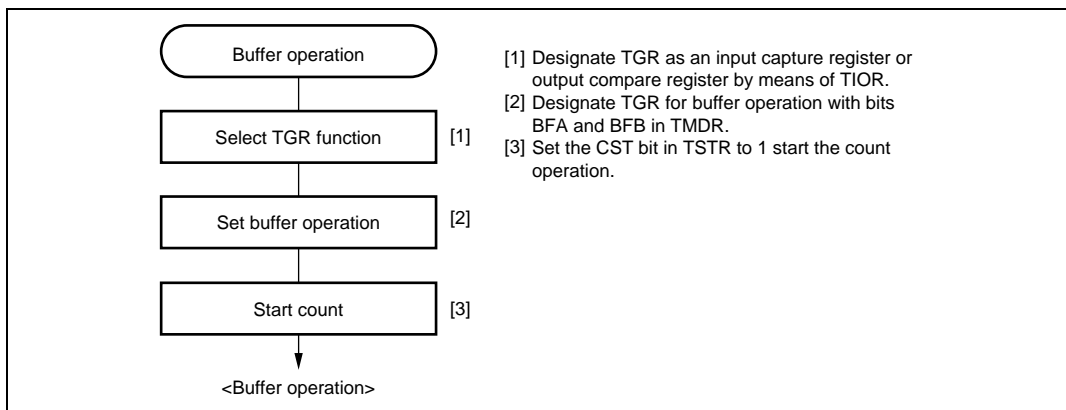

Figure 10.14 Example of Buffer Operation Setting Procedure

Examples of Buffer Operation:

1. When TGR is an output compare register

Figure 10.15 shows an operation example in which PWM mode 1 has been designated for channel 0, and buffer operation has been designated for TGRA and TGRC. The settings used in this example are TCNT clearing by compare match B, 1 output at compare match A, and 0 output at compare match B.

As buffer operation has been set, when compare match A occurs the output changes and the value in buffer register TGRC is simultaneously transferred to timer general register TGRA. This operation is repeated each time that compare match A occurs.

For details of PWM modes, see section 10.4.5, PWM Modes.

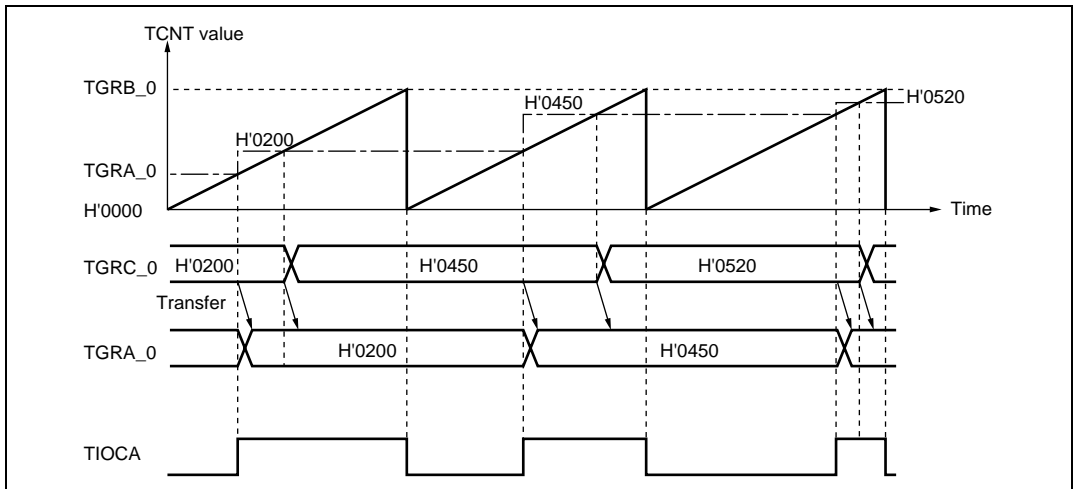

Figure 10.15 Example of Buffer Operation (1)

2. When TGR is an input capture register

Figure 10.16 shows an operation example in which TGRA has been designated as an input capture register, and buffer operation has been designated for TGRA and TGRC.

Counter clearing by TGRA input capture has been set for TCNT, and both rising and falling edges have been selected as the TIOCA pin input capture input edge.

As buffer operation has been set, when the TCNT value is stored in TGRA upon the occurrence of input capture A, the value previously stored in TGRA is simultaneously transferred to TGRC.

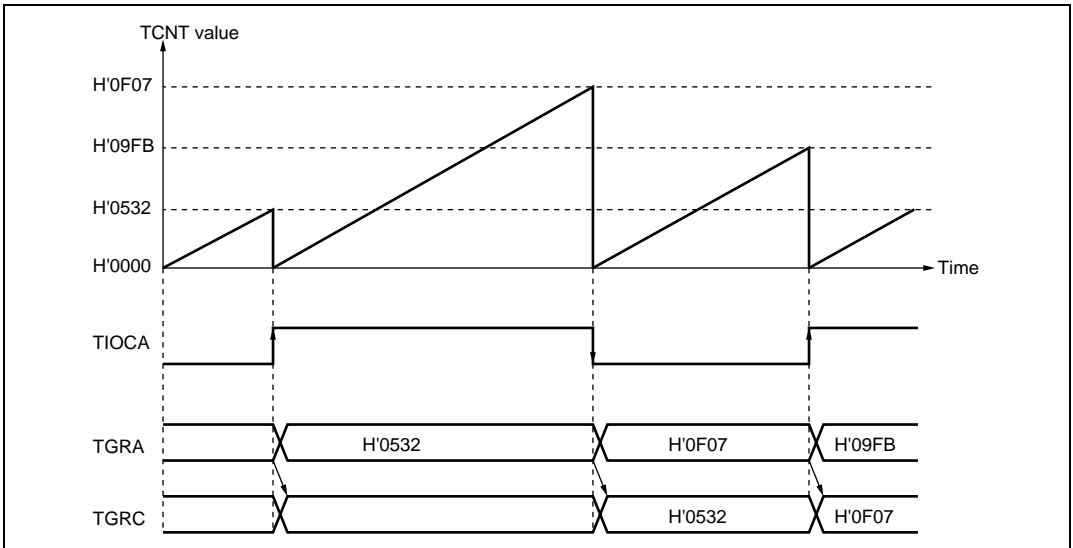

Figure 10.16 Example of Buffer Operation (2)

10.4.4 Cascaded Operation

In cascaded operation, two 16-bit counters for different channels are used together as a 32-bit counter.

This function works by counting the channel 1 (channel 4) counter clock upon overflow/underflow of TCNT_2 (TCNT_5) as set in bits TPSC0 to TPSC2 in TCR.

Underflow occurs only when the lower 16-bit TCNT is in phase-counting mode.

Table 10.29 shows the register combinations used in cascaded operation.

Note: When phase counting mode is set for channel 1 or 4, the counter clock setting is invalid and the counters operates independently in phase counting mode.

Table 10.29 Cascaded Combinations

Combination	Upper 16 Bits	Lower 16 Bits
Channels 1 and 2	TCNT_1	TCNT_2
Channels 4 and 5	TCNT_4	TCNT_5

Example of Cascaded Operation Setting Procedure: Figure 10.17 shows an example of the setting procedure for cascaded operation.

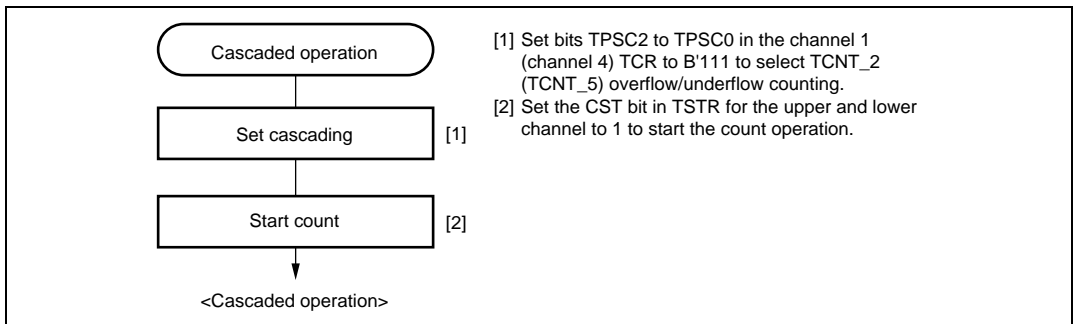

Figure 10.17 Cascaded Operation Setting Procedure

Examples of Cascaded Operation: Figure 10.18 illustrates the operation when TCNT_2 overflow/underflow counting has been set for TCNT_1, when TGRA_1 and TGRA_2 have been designated as input capture registers, and when TIOC pin rising edge has been selected.

When a rising edge is input to the TIOCA1 and TIOCA2 pins simultaneously, the upper 16 bits of the 32-bit data are transferred to TGRA_1, and the lower 16 bits to TGRA_2.

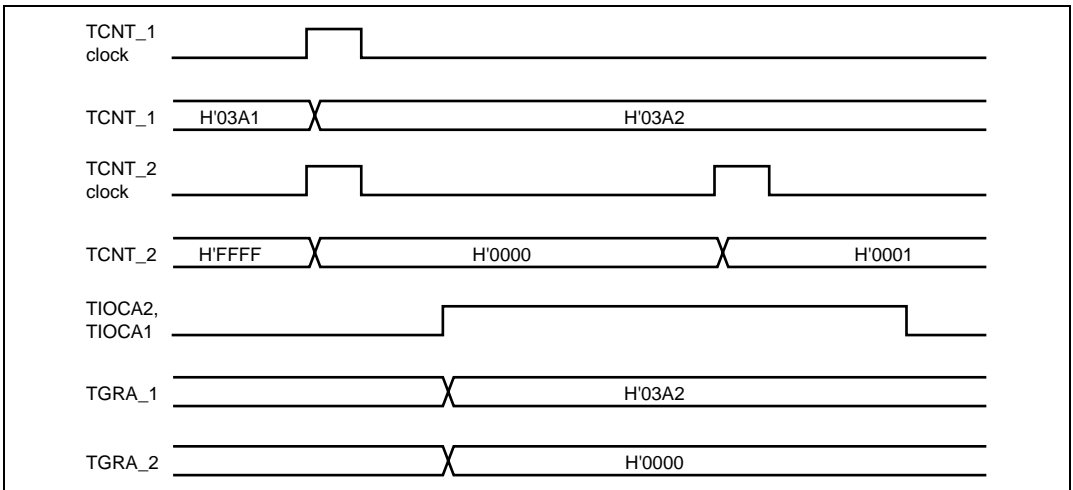

Figure 10.18 Example of Cascaded Operation (1)

Figure 10.19 illustrates the operation when TCNT_2 overflow/underflow counting has been set for TCNT_1 and phase counting mode has been designated for channel 2.

TCNT_1 is incremented by TCNT_2 overflow and decremented by TCNT_2 underflow.

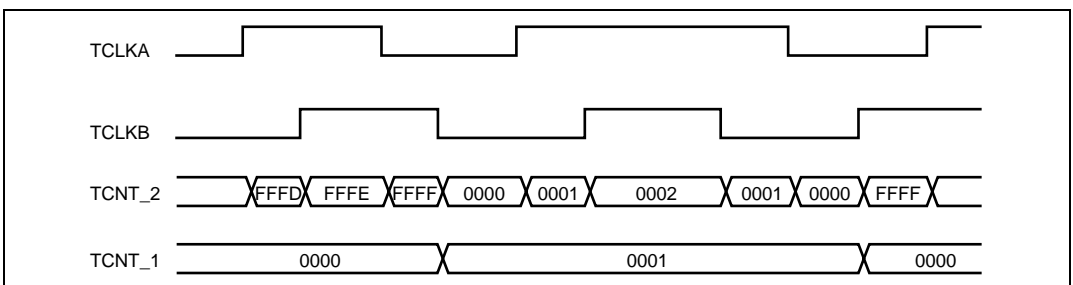

Figure 10.19 Example of Cascaded Operation (2)

10.4.5 PWM Modes

In PWM mode, PWM waveforms are output from the output pins. The output level can be selected as 0, 1, or toggle output in response to a compare match of each TGR.

TGR registers settings can be used to output a PWM waveform in the range of 0% to 100% duty cycle.

Designating TGR compare match as the counter clearing source enables the period to be set in that register. All channels can be designated for PWM mode independently. Synchronous operation is also possible.

There are two PWM modes, as described below.

- PWM mode 1

PWM output is generated from the TIOCA and TIOCC pins by pairing TGRA with TGRB and TGRC with TGRD. The output specified by bits IOA3 to IOA0 and IOC3 to IOC0 in TIOR is output from the TIOCA and TIOCC pins at compare matches A and C, and the output specified by bits IOB3 to IOB0 and IOD3 to IOD0 in TIOR is output at compare matches B and D. The initial output value is the value set in TGRA or TGRC. If the set values of paired TGRs are identical, the output value does not change when a compare match occurs.

In PWM mode 1, a maximum 8-phase PWM output is possible.

- PWM mode 2

PWM output is generated using one TGR as the cycle register and the others as duty cycle registers. The output specified in TIOR is performed by means of compare matches. Upon counter clearing by a duty cycle register compare match, the output value of each pin is the initial value set in TIOR. If the set values of the cycle and duty cycle registers are identical, the output value does not change when a compare match occurs.

In PWM mode 2, a maximum 15-phase PWM output is possible in combination use with synchronous operation.

The correspondence between PWM output pins and registers is shown in table 10.30.

Table 10.30 PWM Output Registers and Output Pins

Channel	Registers	Output Pins	
		PWM Mode 1	PWM Mode 2
0	TGRA_0	TIOCA0	TIOCA0
	TGRB_0		TIOCB0
	TGRC_0	TIOCC0	TIOCC0
	TGRD_0		TIOCD0
1	TGRA_1	TIOCA1	TIOCA1
	TGRB_1		TIOCB1
2	TGRA_2	TIOCA2	TIOCA2
	TGRB_2		TIOCB2
3	TGRA_3	TIOCA3	TIOCA3
	TGRB_3		TIOCB3
	TGRC_3	TIOCC3	TIOCC3
	TGRD_3		TIOCD3
4	TGR4A_4	TIOCA4	TIOCA4
	TGR4B_4		TIOCB4
5	TGRA_5	TIOCA5	TIOCA5
	TGRB_5		TIOCB5

Note: * In PWM mode 2, PWM output is not possible for the TGR register in which the period is set.

Example of PWM Mode Setting Procedure: Figure 10.20 shows an example of the PWM mode setting procedure.

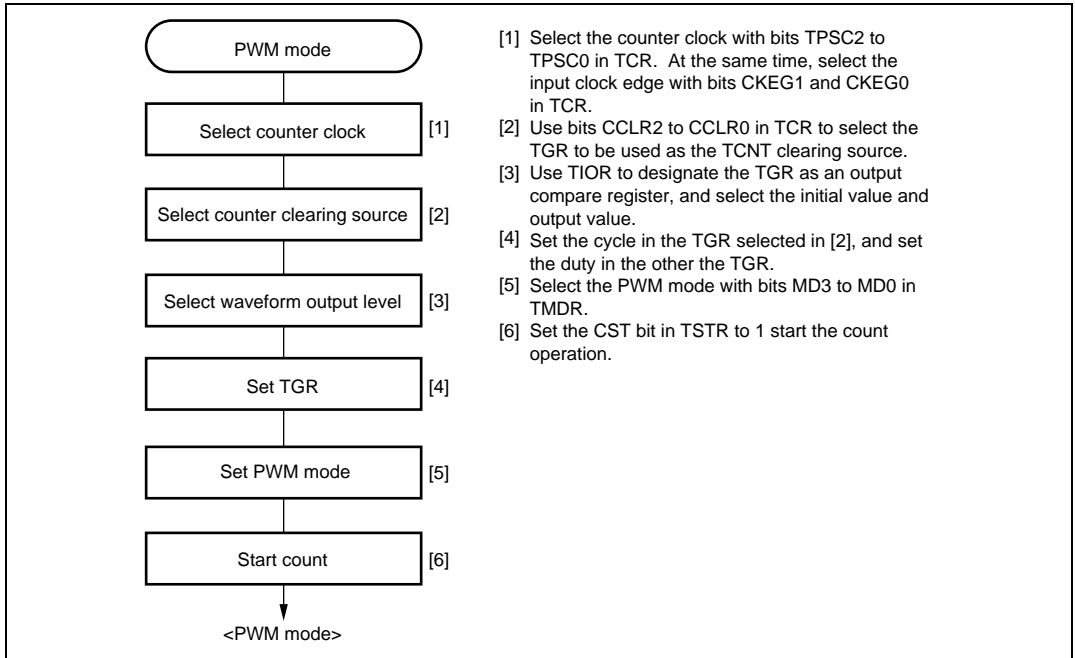

Figure 10.20 Example of PWM Mode Setting Procedure

Examples of PWM Mode Operation: Figure 10.21 shows an example of PWM mode 1 operation.

In this example, TGRA compare match is set as the TCNT clearing source, 0 is set for the TGRA initial output value and output value, and 1 is set as the TGRB output value.

In this case, the value set in TGRA is used as the period, and the values set in the TGRB registers are used as the duty cycle levels.

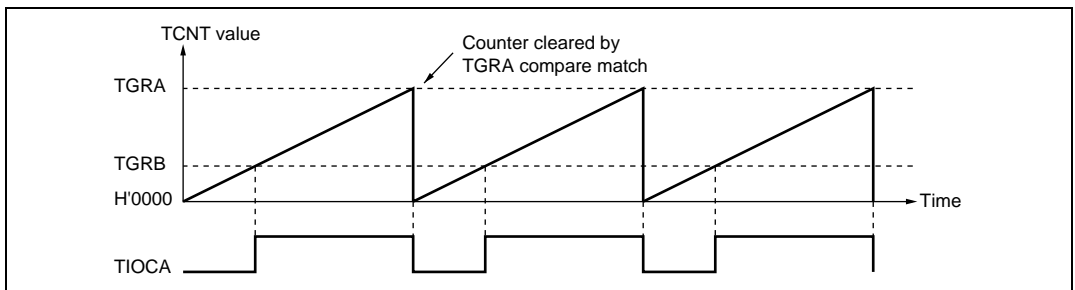

Figure 10.21 Example of PWM Mode Operation (1)

Figure 10.22 shows an example of PWM mode 2 operation.

In this example, synchronous operation is designated for channels 0 and 1, TGRB_1 compare match is set as the TCNT clearing source, and 0 is set for the initial output value and 1 for the output value of the other TGR registers (TGRA_0 to TGRD_0, TGRA_1), outputting a 5-phase PWM waveform.

In this case, the value set in TGRB_1 is used as the cycle, and the values set in the other TGRs are used as the duty cycle levels.

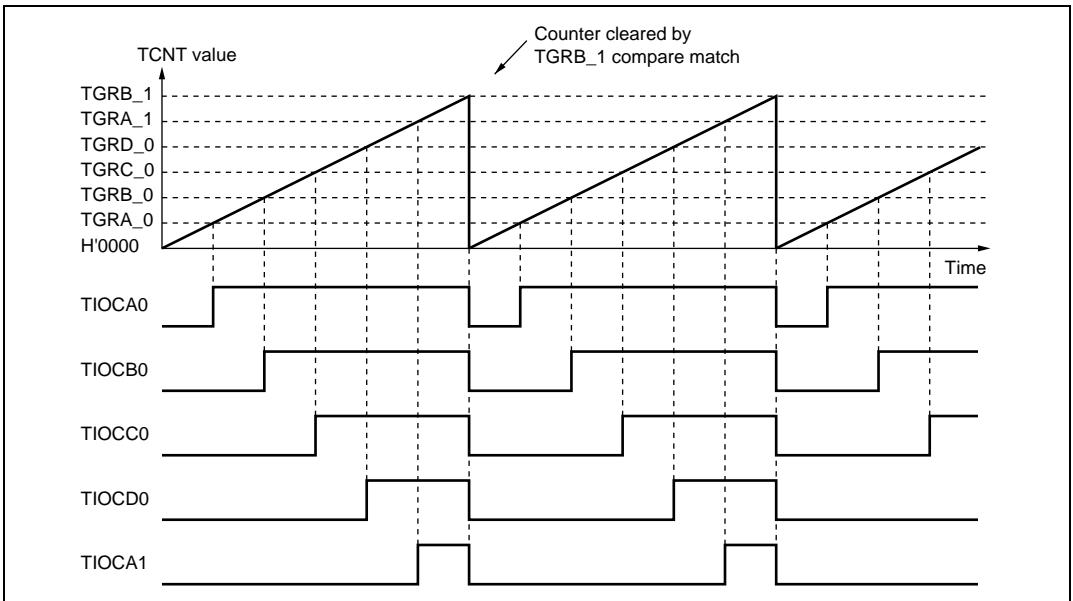

Figure 10.22 Example of PWM Mode Operation (2)

Figure 10.23 shows examples of PWM waveform output with 0% duty cycle and 100% duty cycle in PWM mode.

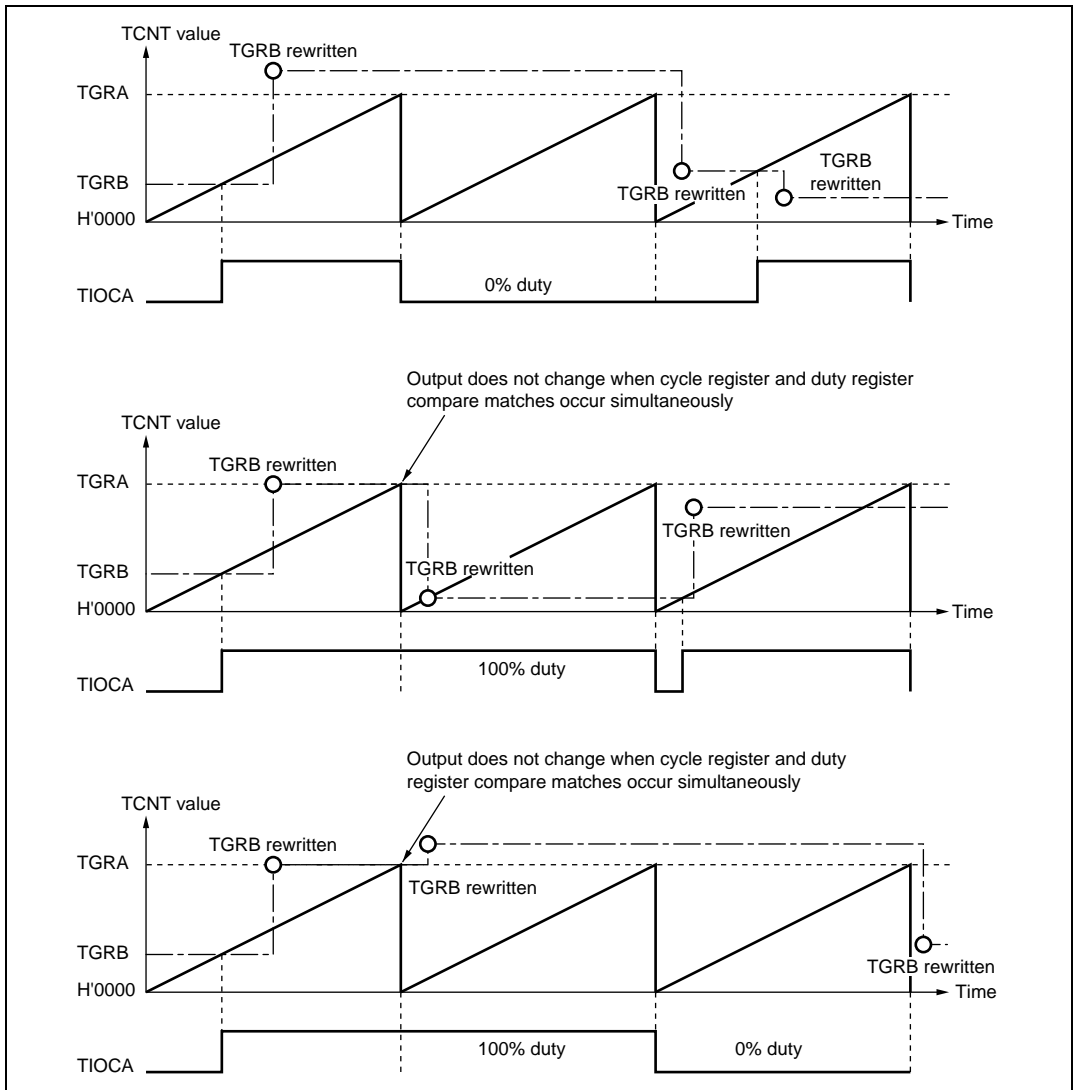

Figure 10.23 Example of PWM Mode Operation (3)

10.4.6 Phase Counting Mode

In phase counting mode, the phase difference between two external clock inputs is detected and TCNT is incremented/decremented accordingly. This mode can be set for channels 1, 2, 4, and 5.

When phase counting mode is set, an external clock is selected as the counter input clock and TCNT operates as an up/down-counter regardless of the setting of bits TPSC2 to TPSC0 and bits CKEG1 and CKEG0 in TCR. However, the functions of bits CCLR1 and CCLR0 in TCR, and of TIOR, TIER, and TGR, are valid, and input capture/compare match and interrupt functions can be used.

This can be used for two-phase encoder pulse input.

If overflow occurs when TCNT is counting up, the TCFV flag in TSR is set; if underflow occurs when TCNT is counting down, the TCFU flag is set.

The TCFD bit in TSR is the count direction flag. Reading the TCFD flag reveals whether TCNT is counting up or down.

Table 10.31 shows the correspondence between external clock pins and channels.

Table 10.31 Phase Counting Mode Clock Input Pins

Channels	External Clock Pins	
	A-Phase	B-Phase
When channel 1 or 5 is set to phase counting mode	TCLKA	TCLKB
When channel 2 or 4 is set to phase counting mode	TCLKC	TCLKD

Example of Phase Counting Mode Setting Procedure: Figure 10.24 shows an example of the phase counting mode setting procedure.

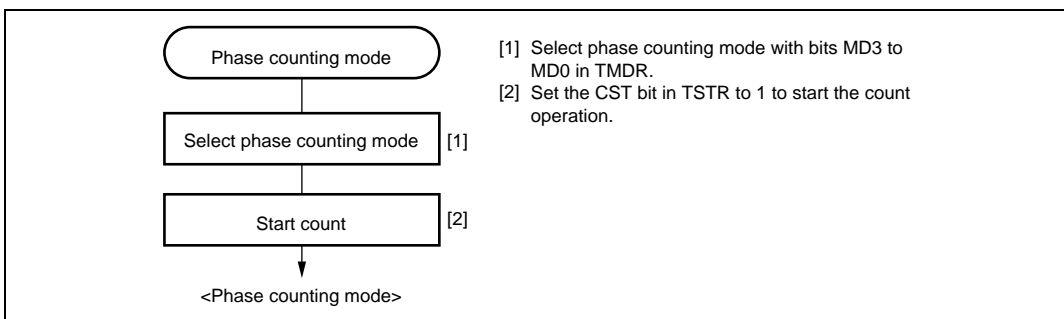

Figure 10.24 Example of Phase Counting Mode Setting Procedure

Examples of Phase Counting Mode Operation: In phase counting mode, TCNT counts up or down according to the phase difference between two external clocks. There are four modes, according to the count conditions.

1. Phase counting mode 1

Figure 10.25 shows an example of phase counting mode 1 operation, and table 10.32 summarizes the TCNT up/down-count conditions.

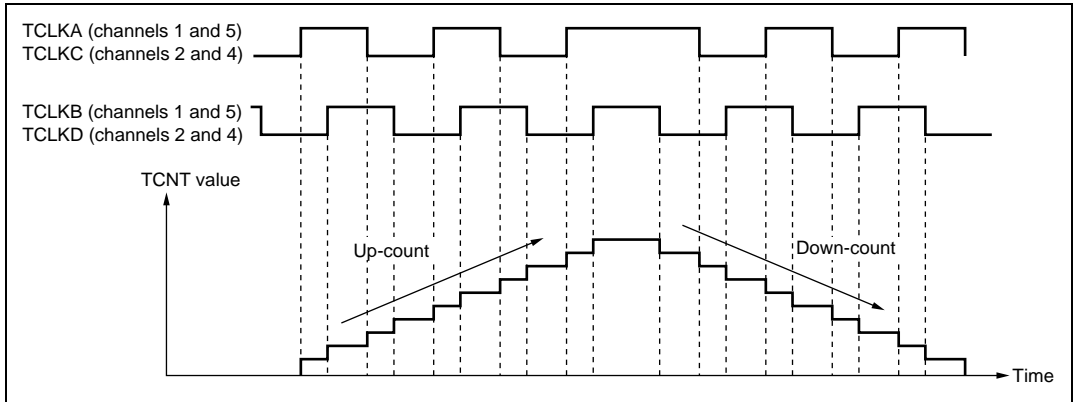

Figure 10.25 Example of Phase Counting Mode 1 Operation

Table 10.32 Up/Down-Count Conditions in Phase Counting Mode 1

TCLKA (Channels 1 and 5) TCLKC (Channels 2 and 4)	TCLKB (Channels 1 and 5) TCLKD (Channels 2 and 4)	Operation
High level		Up-count
Low level		
	Low level	
	High level	
High level		Down-count
Low level		
	High level	
	Low level	

Legend:

: Rising edge

: Falling edge

2. Phase counting mode 2

Figure 10.26 shows an example of phase counting mode 2 operation, and table 10.33 summarizes the TCNT up/down-count conditions.

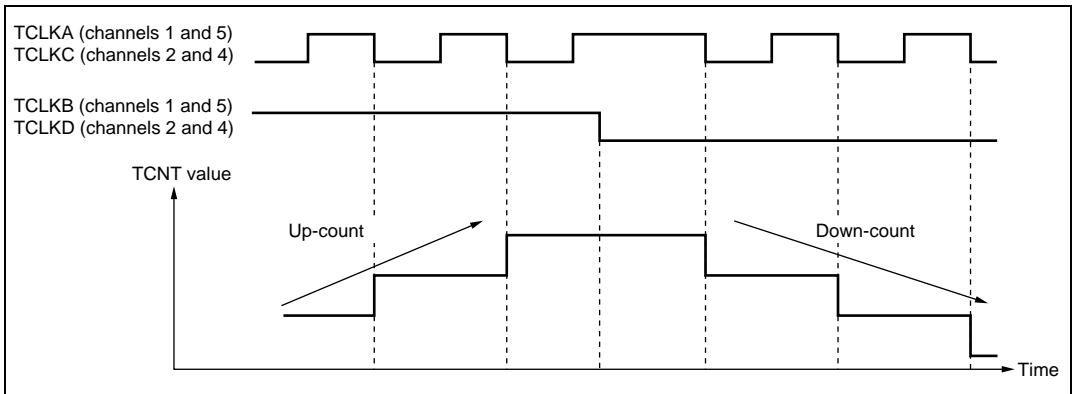

Figure 10.26 Example of Phase Counting Mode 2 Operation

Table 10.33 Up/Down-Count Conditions in Phase Counting Mode 2

TCLKA (Channels 1 and 5) TCLKC (Channels 2 and 4)	TCLKB (Channels 1 and 5) TCLKD (Channels 2 and 4)	Operation
High level		Don't care
Low level		Don't care
	Low level	Don't care
	High level	Up-count
High level		Don't care
Low level		Don't care
	High level	Don't care
	Low level	Down-count

Legend:

: Rising edge

: Falling edge

3. Phase counting mode 3

Figure 10.27 shows an example of phase counting mode 3 operation, and table 10.34 summarizes the TCNT up/down-count conditions.

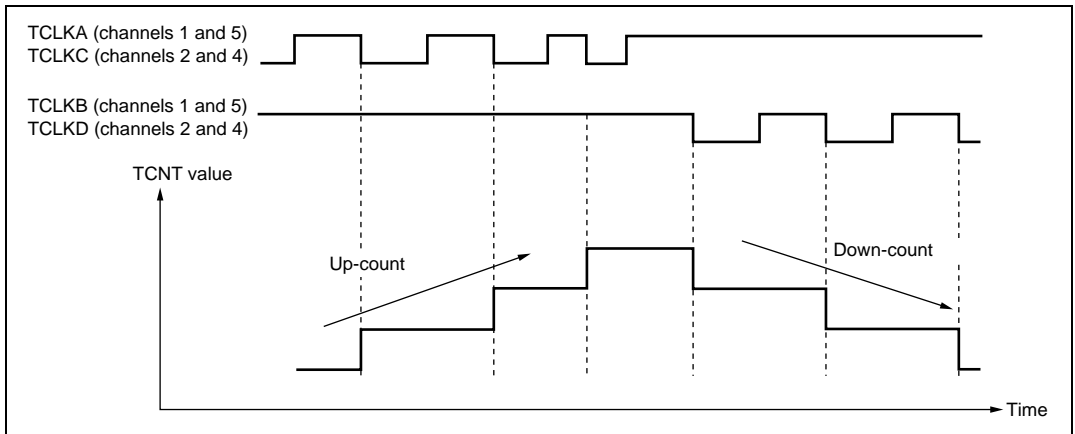

Figure 10.27 Example of Phase Counting Mode 3 Operation

Table 10.34 Up/Down-Count Conditions in Phase Counting Mode 3

TCLKA (Channels 1 and 5) TCLKC (Channels 2 and 4)	TCLKB (Channels 1 and 5) TCLKD (Channels 2 and 4)	Operation
High level		Don't care
Low level		Don't care
	Low level	Don't care
	High level	Up-count
High level		Down-count
Low level		Don't care
	High level	Don't care
	Low level	Don't care

Legend:

: Rising edge

: Falling edge

4. Phase counting mode 4

Figure 10.28 shows an example of phase counting mode 4 operation, and table 10.35 summarizes the TCNT up/down-count conditions.

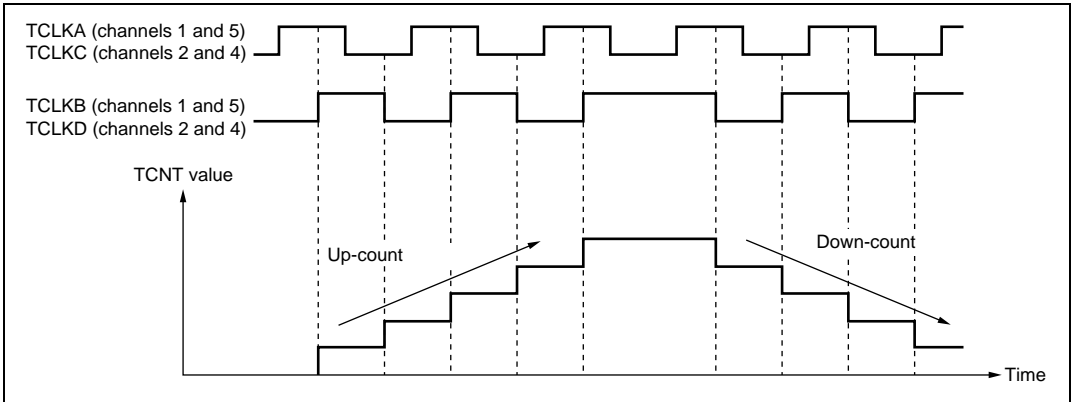

Figure 10.28 Example of Phase Counting Mode 4 Operation

Table 10.35 Up/Down-Count Conditions in Phase Counting Mode 4

TCLKA (Channels 1 and 5) TCLKC (Channels 2 and 4)	TCLKB (Channels 1 and 5) TCLKD (Channels 2 and 4)	Operation
High level		Up-count
Low level		Up-count
	Low level	Don't care
	High level	Don't care
High level		Down-count
Low level		Down-count
	High level	Don't care
	Low level	Don't care

Legend:

: Rising edge

: Falling edge

Phase Counting Mode Application Example: Figure 10.29 shows an example in which channel 1 is in phase counting mode, and channel 1 is coupled with channel 0 to input servo motor 2-phase encoder pulses in order to detect position or speed.

Channel 1 is set to phase counting mode 1, and the encoder pulse A-phase and B-phase are input to TCLKA and TCLKB.

Channel 0 operates with TCNT counter clearing by TGRC_0 compare match; TGRA_0 and TGRC_0 are used for the compare match function and are set with the speed control period and position control period. TGRB_0 is used for input capture, with TGRB_0 and TGRD_0 operating in buffer mode. The channel 1 counter input clock is designated as the TGRB_0 input capture source, and the pulse widths of 2-phase encoder 4-multiplication pulses are detected.

TGRA_1 and TGRB_1 for channel 1 are designated for input capture, and channel 0 TGRA_0 and TGRC_0 compare matches are selected as the input capture source and store the up/down-counter values for the control periods.

This procedure enables the accurate detection of position and speed.

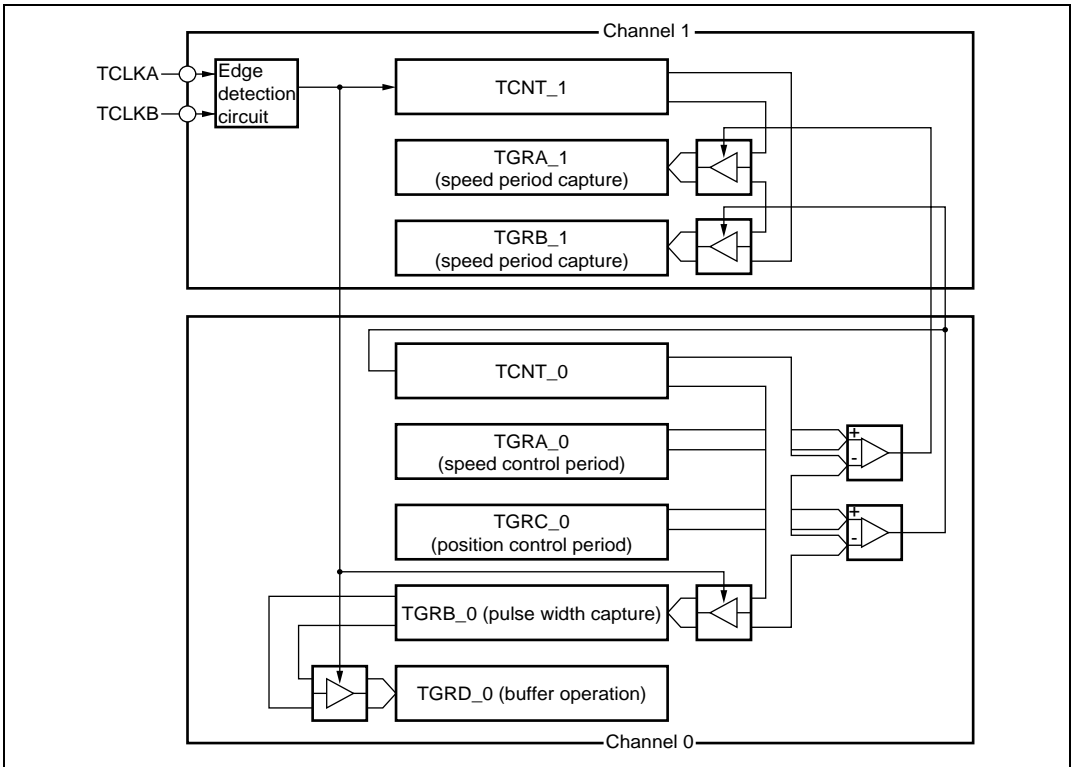

Figure 10.29 Phase Counting Mode Application Example

10.5 Interrupt Sources

There are three kinds of TPU interrupt source; TGR input capture/compare match, TCNT overflow, and TCNT underflow. Each interrupt source has its own status flag and enable/disabled bit, allowing the generation of interrupt request signals to be enabled or disabled individually.

When an interrupt request is generated, the corresponding status flag in TSR is set to 1. If the corresponding enable/disable bit in TIER is set to 1 at this time, an interrupt is requested. The interrupt request is cleared by clearing the status flag to 0.

Relative channel priorities can be changed by the interrupt controller, however the priority order within a channel is fixed. For details, see section 5, Interrupt Controller.

Table 10.36 lists the TPU interrupt sources.

Table 10.36 TPU Interrupts

Channel	Name	Interrupt Source	Interrupt Flag	DTC Activation
0	TGIA_0	TGRA_0 input capture/compare match	TGFA_0	Possible
	TGIB_0	TGRB_0 input capture/compare match	TGFB_0	Possible
	TGIC_0	TGRC_0 input capture/compare match	TGFC_0	Possible
	TGID_0	TGRD_0 input capture/compare match	TGFD_0	Possible
	TCIV_0	TCNT_0 overflow	TCFV_0	Not possible
1	TGIA_1	TGRA_1 input capture/compare match	TGFA_1	Possible
	TGIB_1	TGRB_1 input capture/compare match	TGFB_1	Possible
	TCIV_1	TCNT_1 overflow	TCFV_1	Not possible
	TCIU_1	TCNT_1 underflow	TCFU_1	Not possible
2	TGIA_2	TGRA_2 input capture/compare match	TGFA_2	Possible
	TGIB_2	TGRB_2 input capture/compare match	TGFB_2	Possible
	TCIV_2	TCNT_2 overflow	TCFV_2	Not possible
	TCIU_2	TCNT_2 underflow	TCFU_2	Not possible
3	TGIA_3	TGRA_3 input capture/compare match	TGFA_3	Possible
	TGIB_3	TGRB_3 input capture/compare match	TGFB_3	Possible
	TGIC_3	TGRC_3 input capture/compare match	TGFC_3	Possible
	TGID_3	TGRD_3 input capture/compare match	TGFD_3	Possible
	TCIV_3	TCNT_3 overflow	TCFV_3	Not possible
4	TGIA_4	TGRA_4 input capture/compare match	TGFA_4	Possible
	TGIB_4	TGRB_4 input capture/compare match	TGFB_4	Possible
	TCIV_4	TCNT_4 overflow	TCFV_4	Not possible
	TCIU_4	TCNT_4 underflow	TCFU_4	Not possible
5	TGIA_5	TGRA_5 input capture/compare match	TGFA_5	Possible
	TGIB_5	TGRB_5 input capture/compare match	TGFB_5	Possible
	TCIV_5	TCNT_5 overflow	TCFV_5	Not possible
	TCIU_5	TCNT_5 underflow	TCFU_5	Not possible

Note: * This table shows the initial state immediately after a reset. The relative channel priorities can be changed by the interrupt controller.

Input Capture/Compare Match Interrupt: An interrupt is requested if the TGIE bit in TIER is set to 1 when the TGF flag in TSR is set to 1 by the occurrence of a TGR input capture/compare match on a particular channel. The interrupt request is cleared by clearing the TGF flag to 0. The TPU has 16 input capture/compare match interrupts, four each for channels 0 and 3, and two each for channels 1, 2, 4, and 5.

Overflow Interrupt: An interrupt is requested if the TCIEV bit in TIER is set to 1 when the TCFV flag in TSR is set to 1 by the occurrence of TCNT overflow on a channel. The interrupt request is cleared by clearing the TCFV flag to 0. The TPU has six overflow interrupts, one for each channel.

Underflow Interrupt: An interrupt is requested if the TCIEU bit in TIER is set to 1 when the TCFU flag in TSR is set to 1 by the occurrence of TCNT underflow on a channel. The interrupt request is cleared by clearing the TCFU flag to 0. The TPU has four underflow interrupts, one each for channels 1, 2, 4, and 5.

10.6 DTC Activation

The DTC can be activated by the TGR input capture/compare match interrupt for a channel. For details, see section 8, Data Transfer Controller (DTC).

A total of 16 TPU input capture/compare match interrupts can be used as DTC activation sources, four each for channels 0 and 3, and two each for channels 1, 2, 4, and 5.

10.7 A/D Converter Activation

The A/D converter can be activated by the TGRA input capture/compare match for a channel.

If the TTGE bit in TIER is set to 1 when the TGFA flag in TSR is set to 1 by the occurrence of a TGRA input capture/compare match on a particular channel, a request to begin A/D conversion is sent to the A/D converter. If the TPU conversion start trigger has been selected on the A/D converter side at this time, A/D conversion is begun.

In the TPU, a total of six TGRA input capture/compare match interrupts can be used as A/D converter conversion start sources, one for each channel.

10.8 Operation Timing

10.8.1 Input/Output Timing

TCNT Count Timing: Figure 10.30 shows TCNT count timing in internal clock operation, and figure 10.31 shows TCNT count timing in external clock operation.

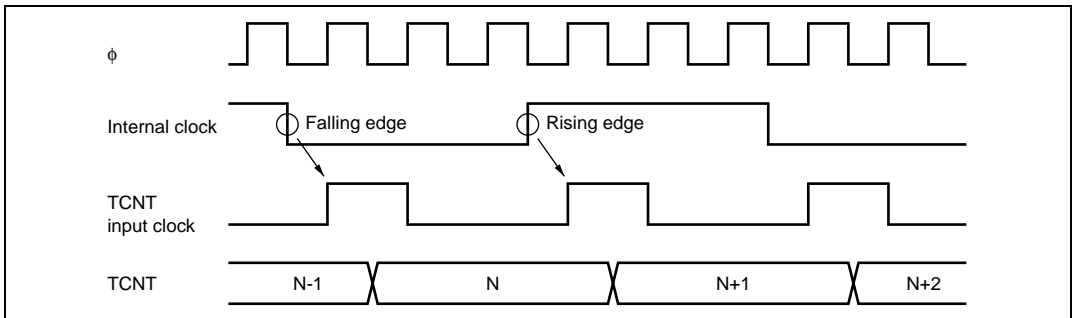

Figure 10.30 Count Timing in Internal Clock Operation

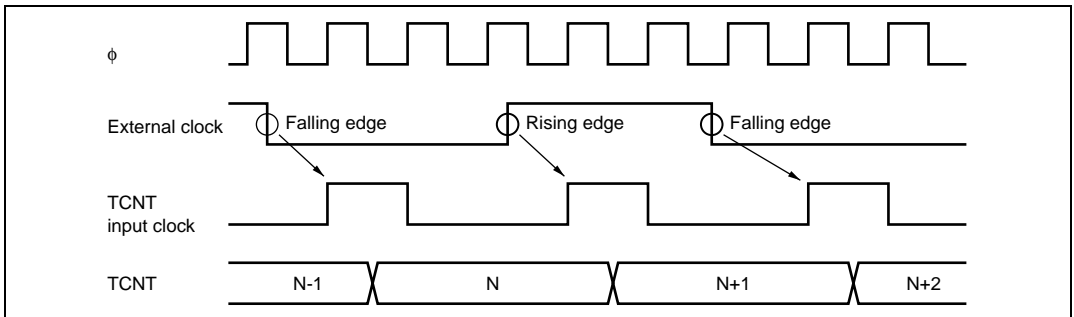

Figure 10.31 Count Timing in External Clock Operation

Output Compare Output Timing: A compare match signal is generated in the final state in which TCNT and TGR match (the point at which the count value matched by TCNT is updated). When a compare match signal is generated, the output value set in TIOR is output at the output compare output pin. After a match between TCNT and TGR, the compare match signal is not generated until the TCNT input clock is generated.

Figure 10.32 shows output compare output timing.

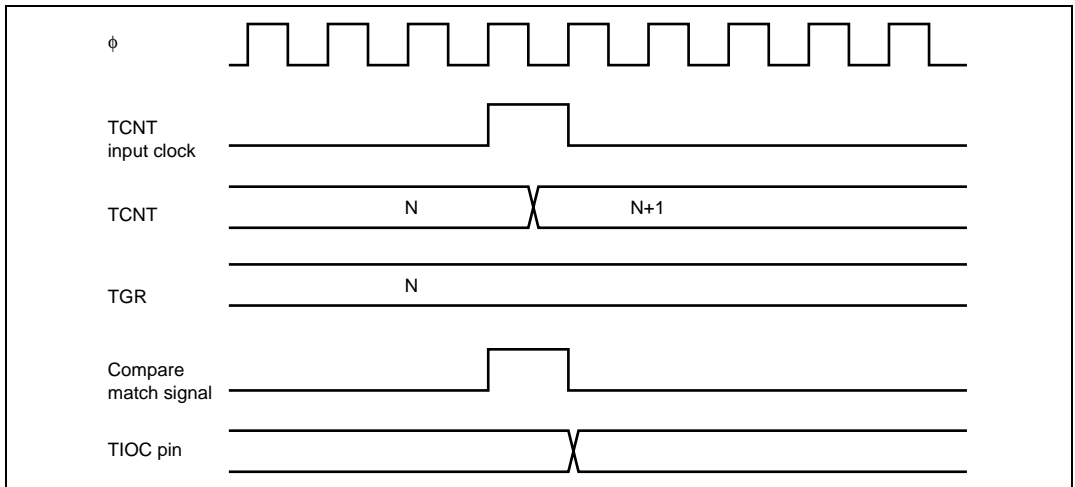

Figure 10.32 Output Compare Output Timing

Input Capture Signal Timing: Figure 10.33 shows input capture signal timing.

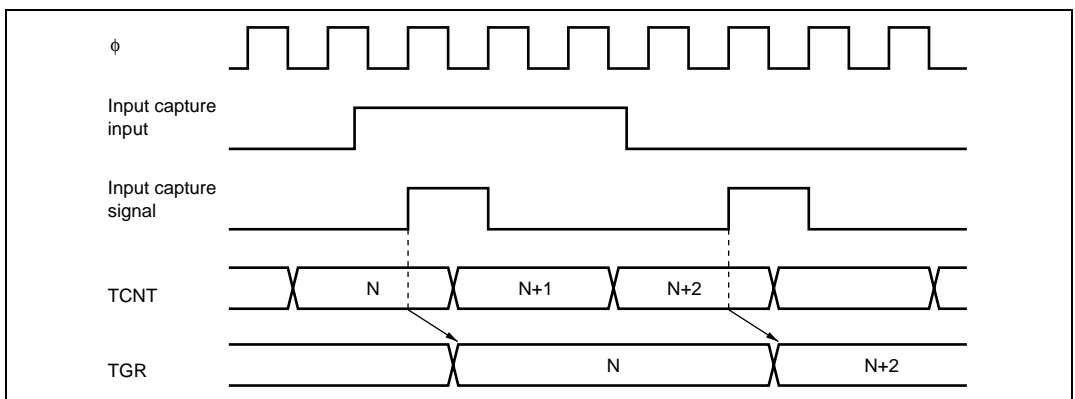

Figure 10.33 Input Capture Input Signal Timing

Timing for Counter Clearing by Compare Match/Input Capture: Figure 10.34 shows the timing when counter clearing on compare match is specified, and figure 10.35 shows the timing when counter clearing on input capture is specified.

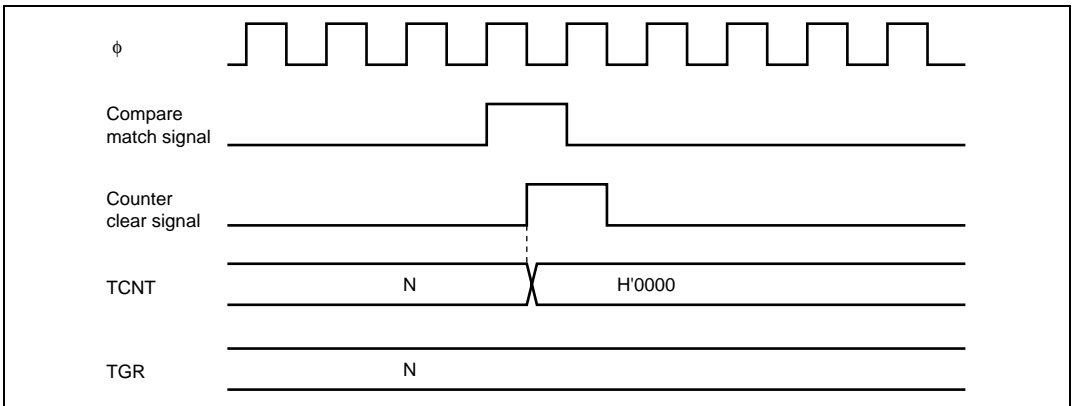

Figure 10.34 Counter Clear Timing (Compare Match)

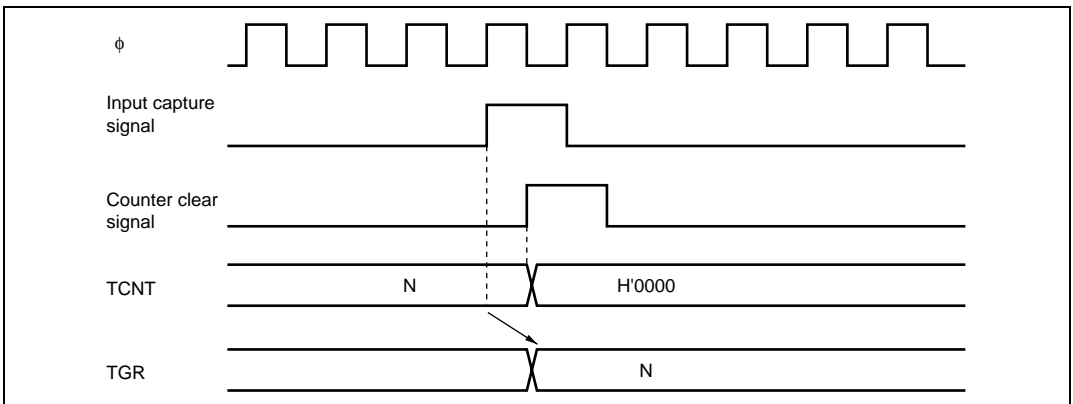

Figure 10.35 Counter Clear Timing (Input Capture)

Buffer Operation Timing: Figures 10.36 and 10.37 show the timing in buffer operation.

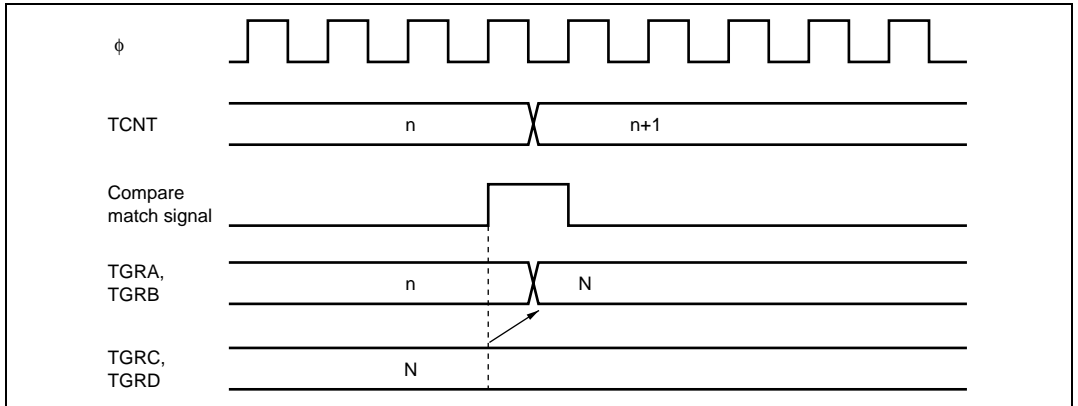

Figure 10.36 Buffer Operation Timing (Compare Match)

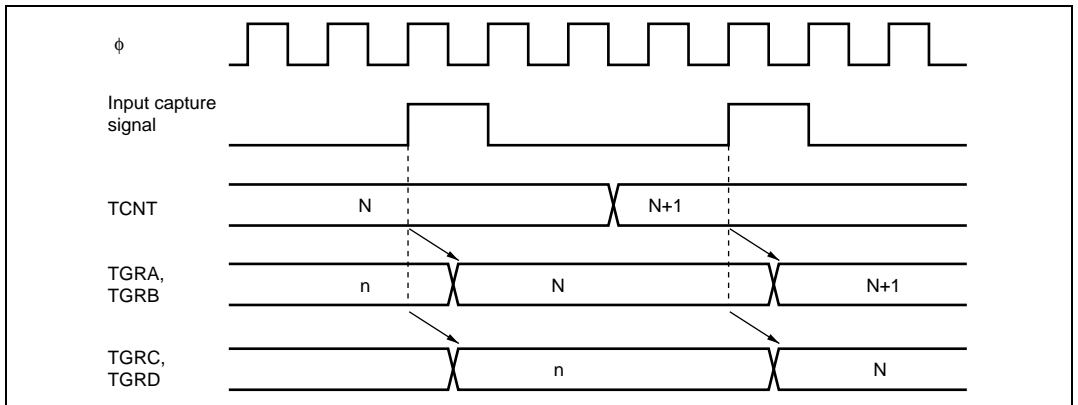

Figure 10.37 Buffer Operation Timing (Input Capture)

10.8.2 Interrupt Signal Timing

TGF Flag Setting Timing in Case of Compare Match: Figure 10.38 shows the timing for setting of the TGF flag in TSR on compare match, and TGI interrupt request signal timing.

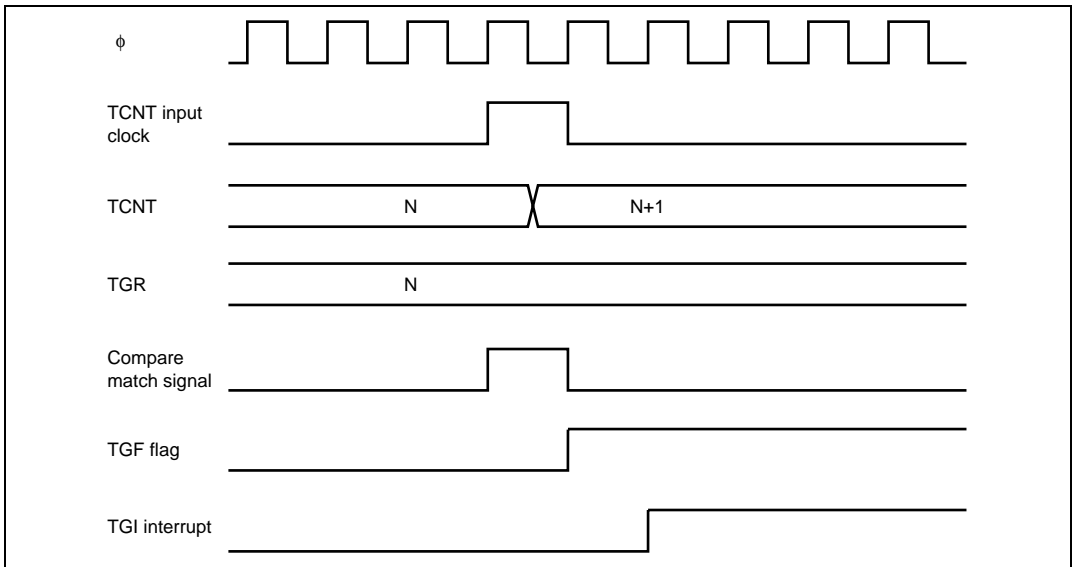

Figure 10.38 TGI Interrupt Timing (Compare Match)

TGF Flag Setting Timing in Case of Input Capture: Figure 10.39 shows the timing for setting of the TGF flag in TSR on input capture, and TGI interrupt request signal timing.

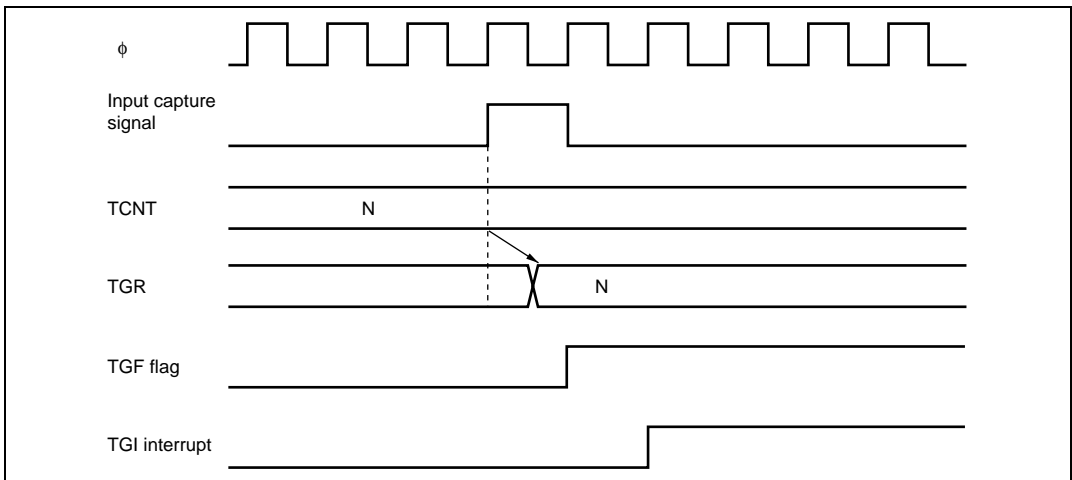

Figure 10.39 TGI Interrupt Timing (Input Capture)

TCFV Flag/TCFU Flag Setting Timing: Figure 10.40 shows the timing for setting of the TCFV flag in TSR on overflow, and TCIV interrupt request signal timing.

Figure 10.41 shows the timing for setting of the TCFU flag in TSR on underflow, and TCIU interrupt request signal timing.

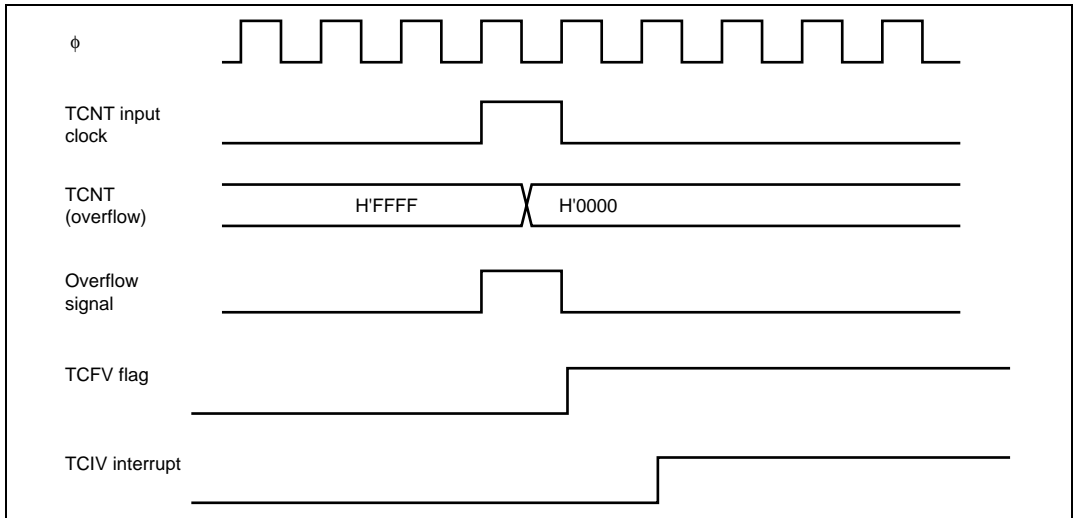

Figure 10.40 TCIV Interrupt Setting Timing

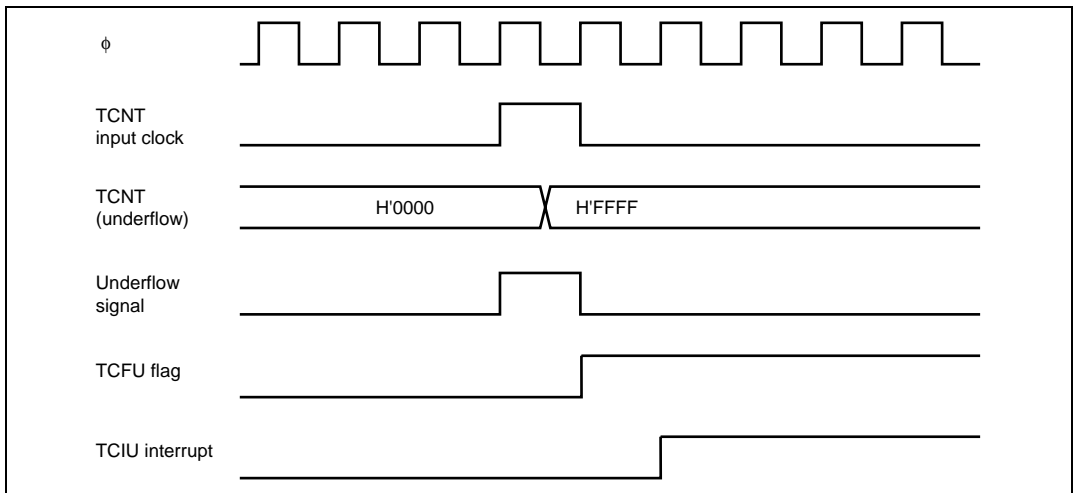

Figure 10.41 TCIU Interrupt Setting Timing

Status Flag Clearing Timing: After a status flag is read as 1 by the CPU, it is cleared by writing 0 to it. When the DTC is activated, the flag is cleared automatically. Figure 10.42 shows the timing for status flag clearing by the CPU, and figure 10.43 shows the timing for status flag clearing by the DTC.

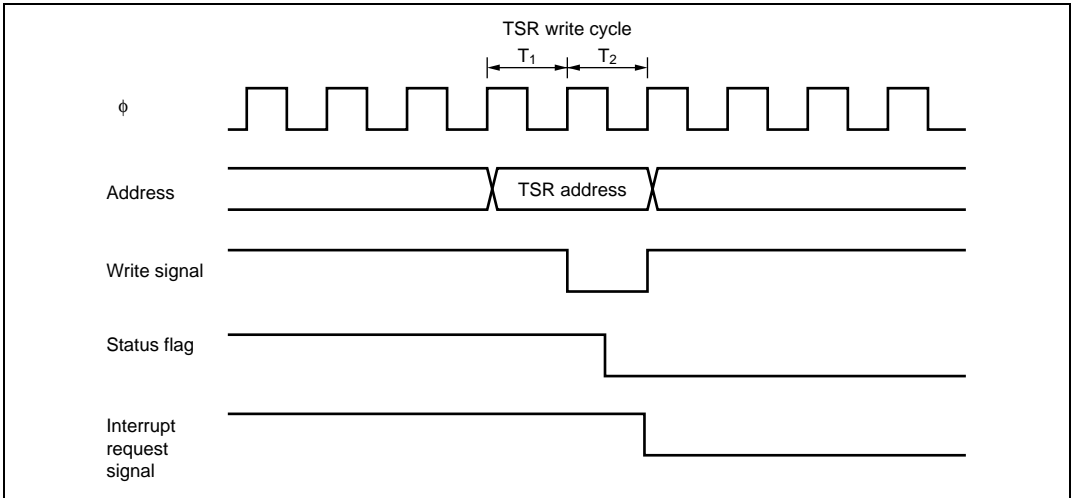

Figure 10.42 Timing for Status Flag Clearing by CPU

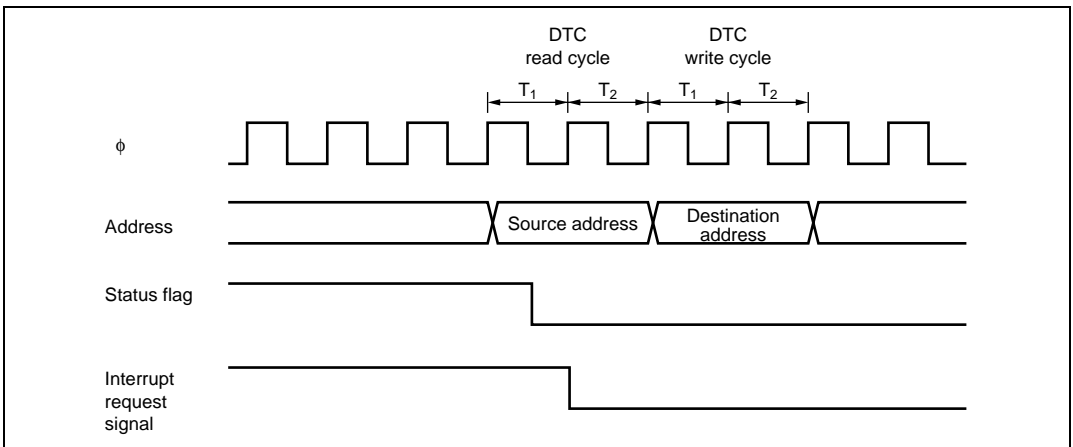

Figure 10.43 Timing for Status Flag Clearing by DTC Activation

10.9 Usage Notes

10.9.1 Module Stop Mode Setting

TPU operation can be disabled or enabled using the module stop control register. The initial setting is for TPU operation to be halted. Register access is enabled by clearing module stop mode. For details, refer to section 21, Power-Down Modes.

10.9.2 Input Clock Restrictions

The input clock pulse width must be at least 1.5 states in the case of single-edge detection, and at least 2.5 states in the case of both-edge detection. The TPU will not operate properly at narrower pulse widths.

In phase counting mode, the phase difference and overlap between the two input clocks must be at least 1.5 states, and the pulse width must be at least 2.5 states. Figure 10.44 shows the input clock conditions in phase counting mode.

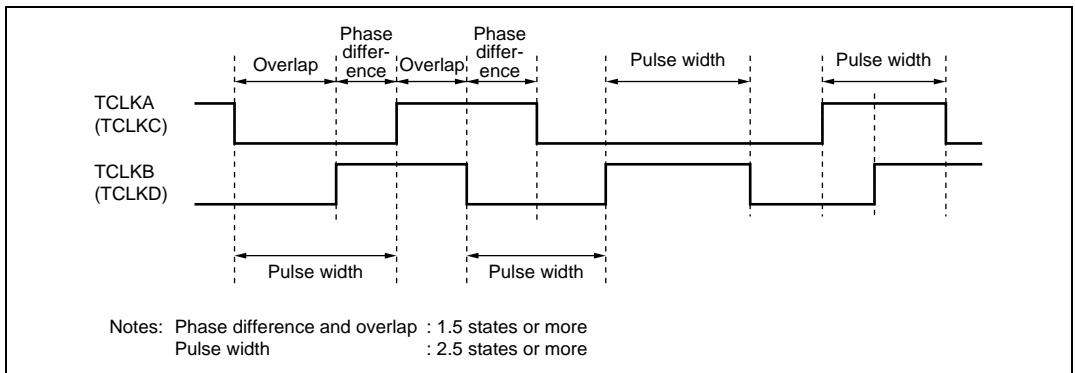

Figure 10.44 Phase Difference, Overlap, and Pulse Width in Phase Counting Mode

10.9.3 Caution on Period Setting

When counter clearing on compare match is set, TCNT is cleared in the final state in which it matches the TGR value (the point at which the count value matched by TCNT is updated). Consequently, the actual counter frequency is given by the following formula:

$$f = \frac{\phi}{(N + 1)}$$

Where f : Counter frequency
 ϕ : Operating frequency
 N : TGR set value

10.9.4 Conflict between TCNT Write and Clear Operations

If the counter clear signal is generated in the T_2 state of a TCNT write cycle, TCNT clearing takes precedence and the TCNT write is not performed.

Figure 10.45 shows the timing in this case.

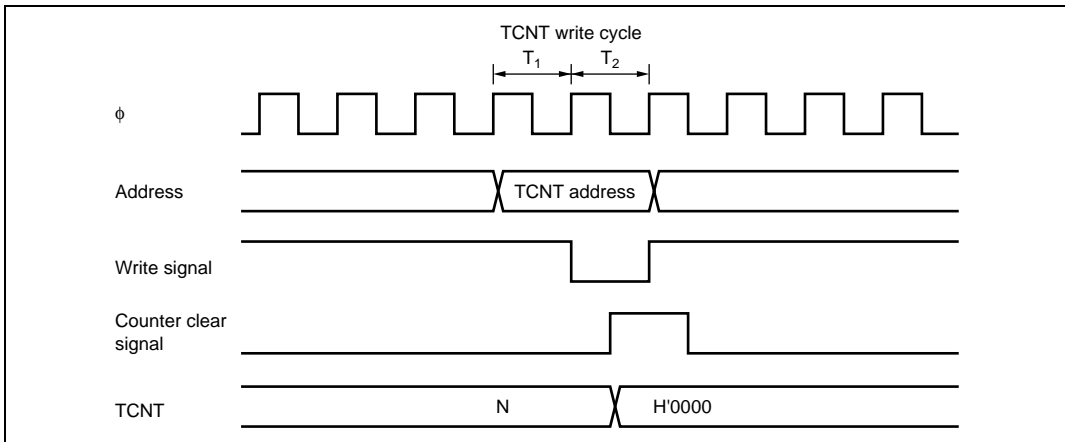

Figure 10.45 Conflict between TCNT Write and Clear Operations

10.9.5 Conflict between TCNT Write and Increment Operations

If incrementing occurs in the T_2 state of a TCNT write cycle, the TCNT write takes precedence and TCNT is not incremented.

Figure 10.46 shows the timing in this case.

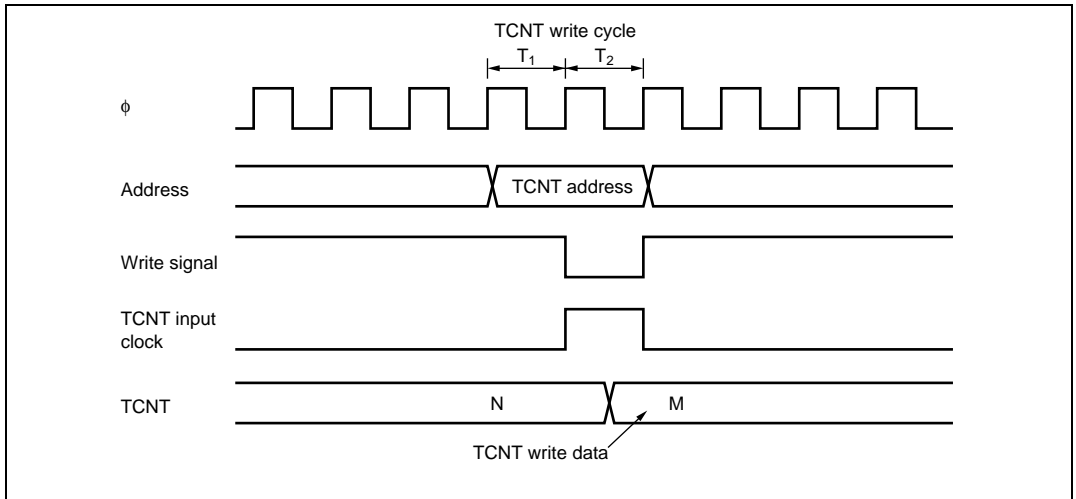

Figure 10.46 Conflict between TCNT Write and Increment Operations

10.9.6 Conflict between TGR Write and Compare Match

If a compare match occurs in the T_2 state of a TGR write cycle, the TGR write takes precedence and the compare match signal is inhibited. A compare match does not occur even if the previous value is written.

Figure 10.47 shows the timing in this case.

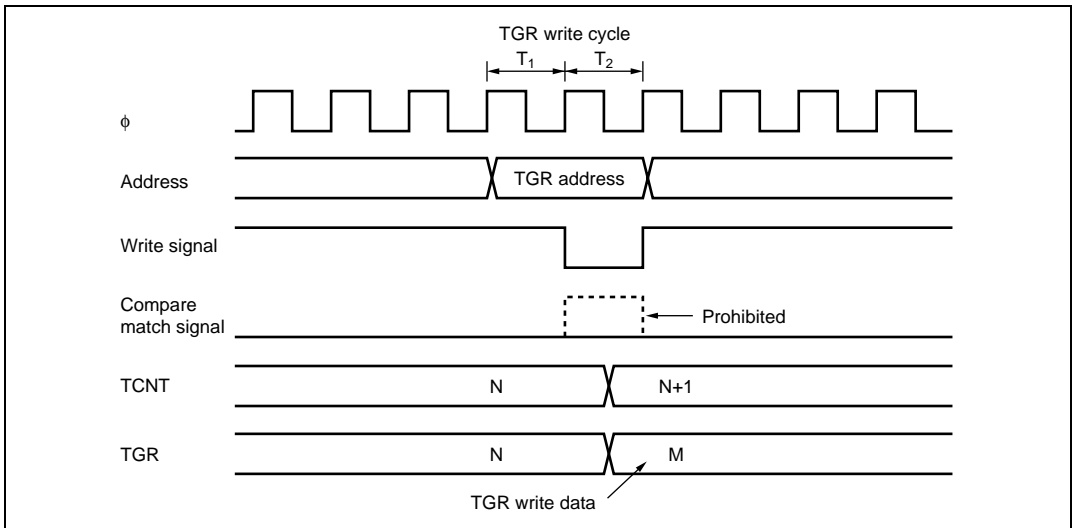

Figure 10.47 Conflict between TGR Write and Compare Match

10.9.7 Conflict between Buffer Register Write and Compare Match

If a compare match occurs in the T_2 state of a TGR write cycle, the data that is transferred to TGR by the buffer operation will be that in the buffer prior to the write.

Figure 10.48 shows the timing in this case.

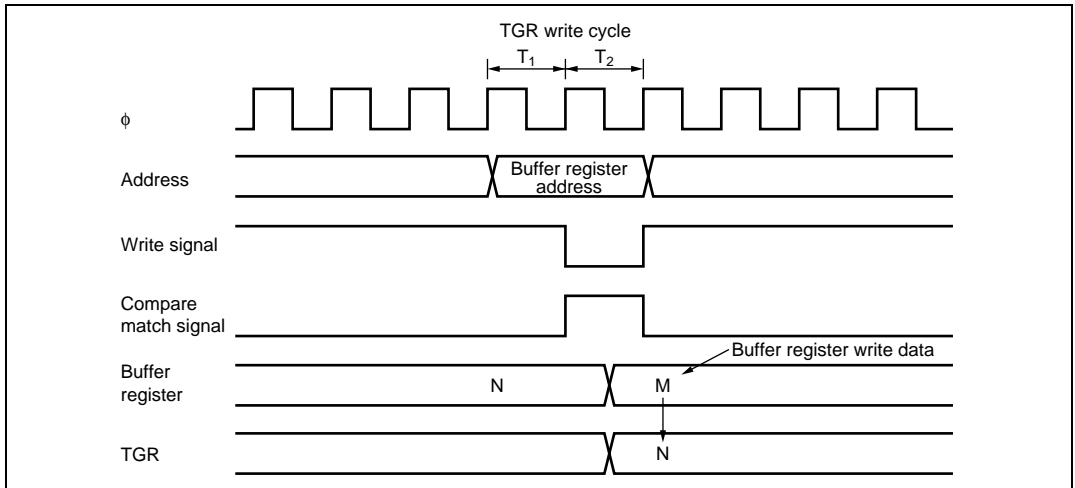

Figure 10.48 Conflict between Buffer Register Write and Compare Match

10.9.8 Conflict between TGR Read and Input Capture

If an input capture signal is generated in the T_1 state of a TGR read cycle, the data that is read will be that in the buffer after input capture transfer.

Figure 10.49 shows the timing in this case.

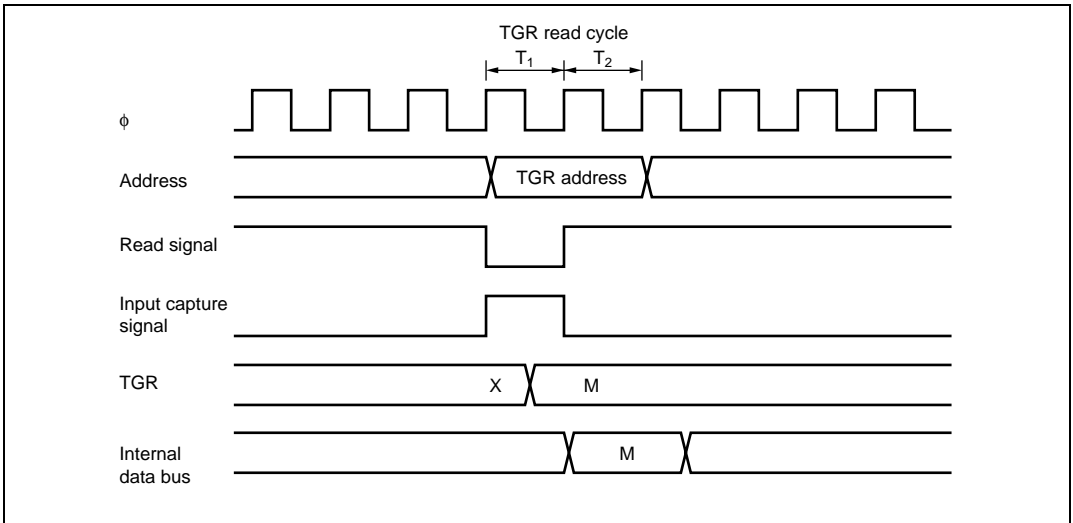

Figure 10.49 Conflict between TGR Read and Input Capture

10.9.9 Conflict between TGR Write and Input Capture

If an input capture signal is generated in the T_2 state of a TGR write cycle, the input capture operation takes precedence and the write to TGR is not performed.

Figure 10.50 shows the timing in this case.

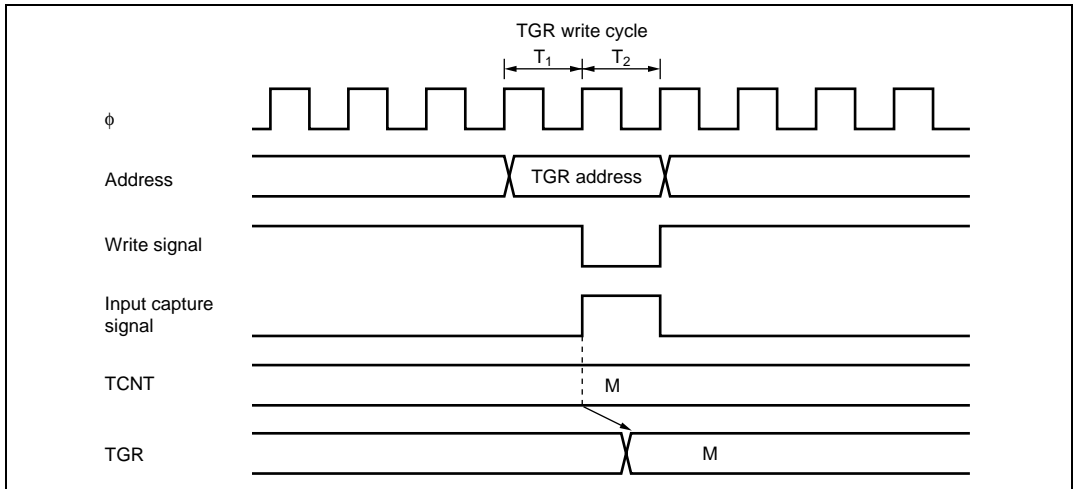

Figure 10.50 Conflict between TGR Write and Input Capture

10.9.10 Conflict between Buffer Register Write and Input Capture

If an input capture signal is generated in the T_2 state of a buffer register write cycle, the buffer operation takes precedence and the write to the buffer register is not performed.

Figure 10.51 shows the timing in this case.

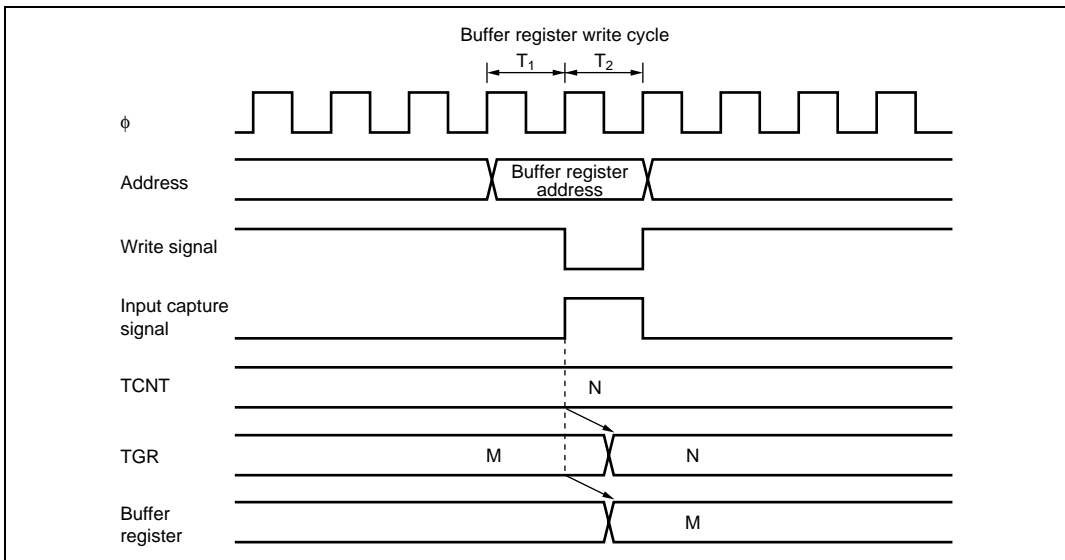

Figure 10.51 Conflict between Buffer Register Write and Input Capture

10.9.11 Conflict between Overflow/Underflow and Counter Clearing

If overflow/underflow and counter clearing occur simultaneously, the TCFV/TCFU flag in TSR is not set and TCNT clearing takes precedence.

Figure 10.52 shows the operation timing when a TGR compare match is specified as the clearing source, and when H'FFFF is set in TGR.

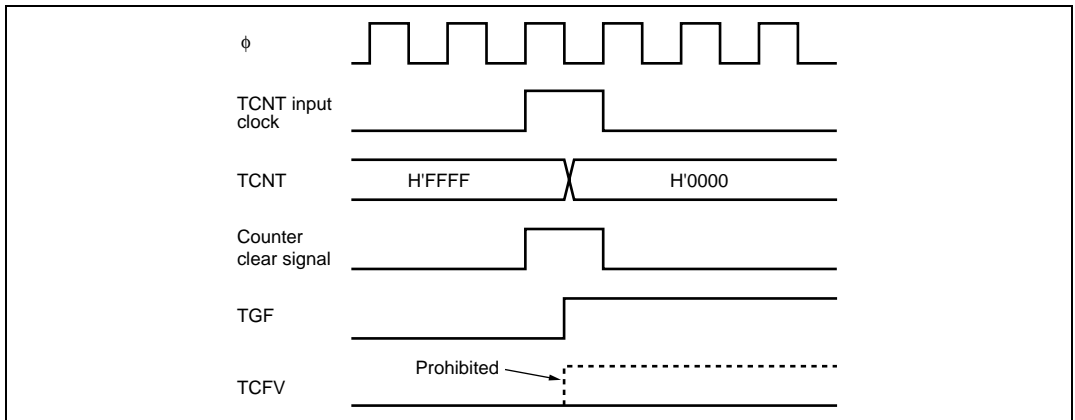

Figure 10.52 Conflict between Overflow and Counter Clearing

10.9.12 Conflict between TCNT Write and Overflow/Underflow

If there is an up-count or down-count in the T_2 state of a TCNT write cycle, and overflow/underflow occurs, the TCNT write takes precedence and the TCFV/TCFU flag in TSR is not set.

Figure 10.53 shows the operation timing when there is conflict between TCNT write and overflow.

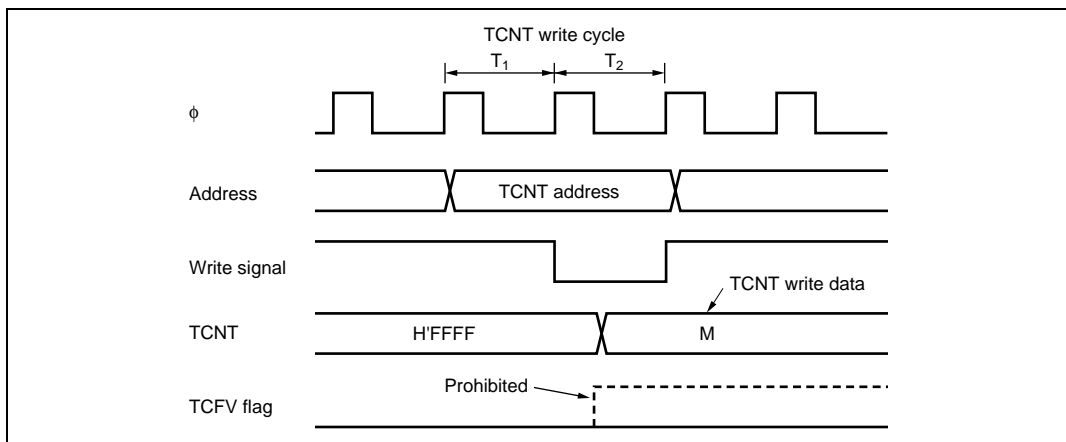

Figure 10.53 Conflict between TCNT Write and Overflow

10.9.13 Multiplexing of I/O Pins

In this LSI, the TCLKA input pin is multiplexed with the TIOCC0 I/O pin, the TCLKB input pin with the TIOCD0 I/O pin, the TCLKC input pin with the TIOCB1 I/O pin, and the TCLKD input pin with the TIOCB2 I/O pin. When an external clock is input, compare match output should not be performed from a multiplexed pin.

10.9.14 Interrupts in Module Stop Mode

If module stop mode is entered when an interrupt has been requested, it will not be possible to clear the CPU interrupt source or the DTC activation source. Interrupts should therefore be disabled before entering module stop mode.

Section 11 8-Bit Timers

This LSI has an on-chip 8-bit timer module with four channels operating on the basis of an 8-bit counter.

The 8-bit timer module can be used to count external events and be used as a multifunction timer in a variety of applications, such as generation of counter reset, interrupt requests, and pulse output with an arbitrary duty cycle using a compare-match signal with two registers.

11.1 Features

- Selection of clock sources
Selected from three internal clocks ($\phi/8$, $\phi/64$, and $\phi/8192$) and an external clock.
- Selection of three ways to clear the counters
The counters can be cleared on compare-match A or B, or by an external reset signal.
- Timer output controlled by two compare-match signals
The timer output signal in each channel is controlled by two independent compare-match signals, enabling the timer to be used for various applications, such as the generation of pulse output or PWM output with an arbitrary duty cycle.
- Cascading of the two channels
 - Cascading of TMR_1 and TMR_0
The module can operate as a 16-bit timer using TMR_0 as the upper half and TMR_1 as the lower half (16-bit count mode).
TMR_1 can be used to count TMR_0 compare-match occurrences (compare-match count mode).
 - Cascading of TMR_3 and TMR_2
The module can operate as a 16-bit timer using TMR_2 as the upper half and TMR_3 as the lower half (16-bit count mode).
TMR_3 can be used to count TMR_2 compare-match occurrences (compare-match count mode).
- Multiple interrupt sources for each channel
Two compare-match interrupts and one overflow interrupt can be requested independently.
- Generation of A/D conversion start trigger
Channel 0 compare-match A signal can be used as the A/D conversion start trigger.
- Module stop mode can be set
At initialization, the 8-bit timer operation is halted. Register access is enabled by canceling the module stop mode.

Figure 11.1 shows a block diagram of the 8-bit timer module (TMR_1 and TMR_0).

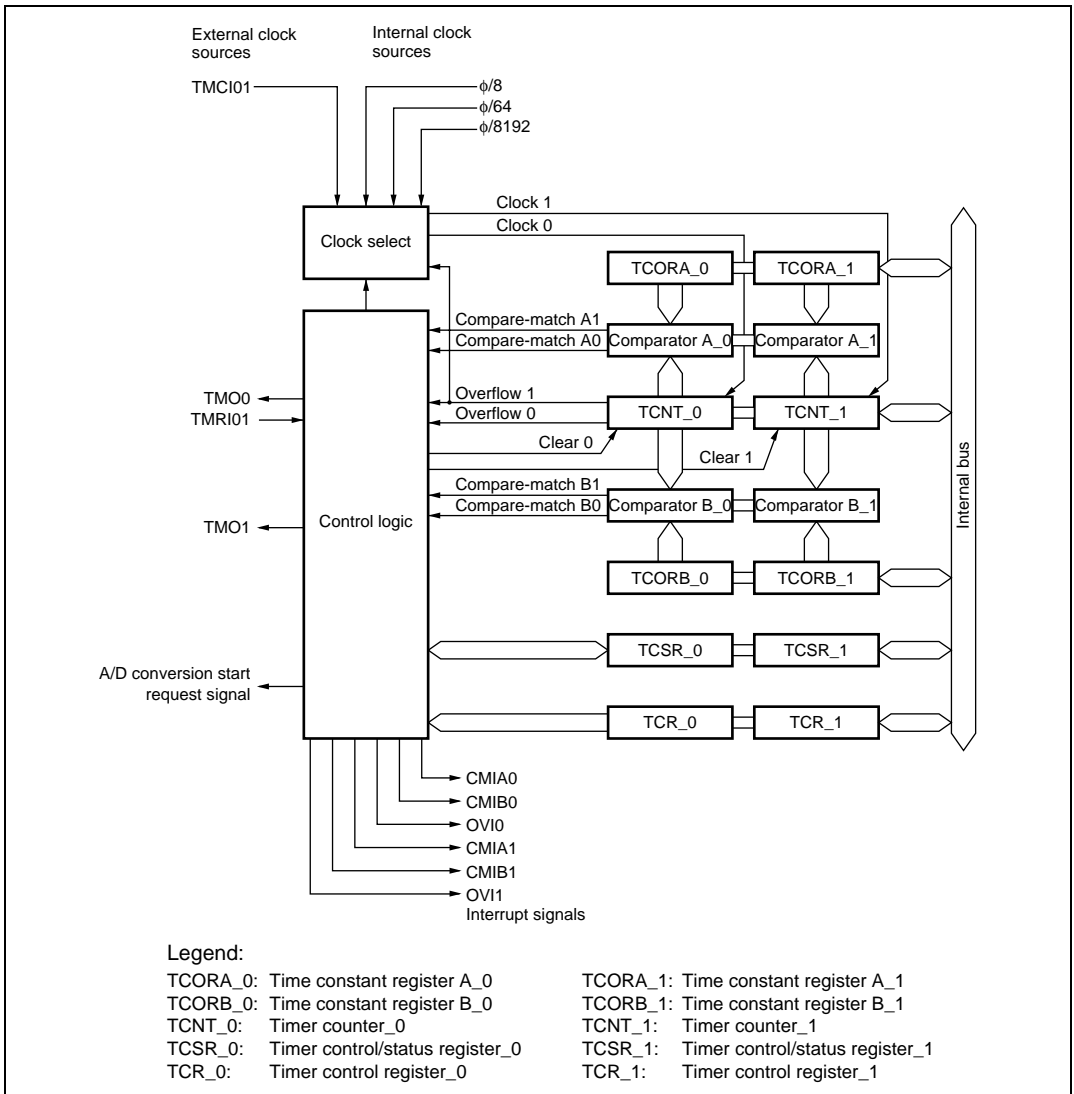

Figure 11.1 Block Diagram of 8-Bit Timer Module

11.2 Input/Output Pins

Table 11.1 summarizes the input and output pins of the 8-bit timer module.

Table 11.1 Pin Configuration

Channel	Name	Symbol	I/O	Function
0	Timer output	TMO0	Output	Output controlled by compare-match
1	Timer output	TMO1	Output	Output controlled by compare-match
Common to 0 and 1	Timer clock input	TMC101	Input	External clock input for the counter
	Timer reset input	TMR101	Input	External reset input for the counter
2	Timer output	TMO2	Output	Output controlled by compare-match
3	Timer output	TMO3	Output	Output controlled by compare-match
Common to 2 and 3	Timer clock input	TMC123	Input	External clock input for the counter
	Timer reset input	TMR123	Input	External reset input for the counter

11.3 Register Descriptions

The 8-bit timer has the following registers. For details on the module stop register, refer to 21.1.2, Module Stop Registers A to C (MSTPCRA to MSTPCRC).

- Timer counter_0 (TCNT_0)
- Time constant register A_0 (TCORA_0)
- Time constant register B_0 (TCORB_0)
- Timer control register_0 (TCR_0)
- Timer control/status register_0 (TCSR_0)
- Timer counter_1 (TCNT_1)
- Time constant register A_1 (TCORA_1)
- Time constant register B_1 (TCORB_1)
- Timer control register_1 (TCR_1)
- Timer control/status register_1 (TCSR_1)
- Timer counter_2 (TCNT_2)
- Time constant register A_2 (TCORA_2)
- Time constant register B_2 (TCORB_2)
- Timer control register_2 (TCR_2)
- Timer control/status register_2 (TCSR_2)
- Timer counter_3 (TCNT_3)

- Time constant register A_3 (TCORA_3)
- Time constant register B_3 (TCORB_3)
- Timer control register_3 (TCR_3)
- Timer control/status register_3 (TCSR_3)

11.3.1 Timer Counters (TCNT)

Each TCNT is an 8-bit up-counter. TCNT_1 and TCNT_0, or TCNT_3 and TCNT_2 comprise a single 16-bit register, so they can be accessed together by word access.

This clock source is selected by clock select bits CKS2 to CKS0 in TCR. TCNT can be cleared by an external reset input signal or compare-match signals A and B. Counter clear bits CCLR1 and CCLR0 in TCR select the method of clearing.

When TCNT overflows from H'FF to H'00, the overflow flag (OVF) in TCSR is set to 1.

The initial value of TCNT is H'00.

11.3.2 Time Constant Registers A (TCORA)

TCORA is an 8-bit readable/writable register. TCORA_3, TCORA_2, TCORA_1 and TCORA_0 comprise a single 16-bit register, so they can be accessed together by word access.

TCORA is continually compared with the value in TCNT. When a match is detected, the corresponding compare-match flag A (CMFA) in TCSR is set. Note, however, that comparison is disabled during the T₂ state of a TCORA write cycle.

The timer output from the TMO pin can be freely controlled by the compare-match signal A and the settings of output select bits OS1 and OS0 in TCSR.

The initial value of TCORA is H'FF.

11.3.3 Time Constant Registers B (TCORB)

TCORB is an 8-bit readable/writable register. TCORB_3, TCORB_2, TCORB_1 and TCORB_0 comprise a single 16-bit register, so they can be accessed together by word access.

TCORB is continually compared with the value in TCNT. When a match is detected, the corresponding compare-match flag B (CMFB) in TCSR is set. Note, however, that comparison is disabled during the T₂ state of a TCORB write cycle.

The timer output from the TMO pin can be freely controlled by the compare-match signal B and the settings of output select bits OS1 and OS0 in TCSR.

The initial value of TCORB is H'FF.

11.3.4 Timer Control Registers (TCR)

TCR selects the TCNT clock source and the time at which TCNT is cleared, and controls interrupt requests.

Bit	Bit Name	Initial Value	R/W	Description
7	CMIEB	0	R/W	Compare-Match Interrupt Enable B Selects whether the CMFB interrupt request (CMIB) is enabled or disabled when the CMFB flag in TCSR is set to 1. 0: CMFB interrupt request (CMIB) is disabled 1: CMFB interrupt request (CMIB) is enabled
6	CMIEA	0	R/W	Compare-Match Interrupt Enable A Selects whether the CMFA interrupt request (CMIA) is enabled or disabled when the CMFA flag in TCSR is set to 1. 0: CMFA interrupt request (CMIA) is disabled 1: CMFA interrupt request (CMIA) is enabled
5	OVIE	0	R/W	Timer Overflow Interrupt Enable Selects whether the OVF interrupt request (OVI) is enabled or disabled when the OVF flag in TCSR is set to 1. 0: OVF interrupt request (OVI) is disabled 1: OVF interrupt request (OVI) is enabled
4	CCLR1	0	R/W	Counter Clear 1 and 0
3	CCLR0	0	R/W	These bits select the method by which TCNT is cleared 00: Clearing is disabled 01: Cleared on compare-match A 10: Cleared on compare-match B 11: Cleared on rising edge of external reset input

Bit	Bit Name	Initial Value	R/W	Description
2	CKS2	0	R/W	Clock Select 2 to 0
1	CKS1	0	R/W	The input clock can be selected from three clocks divided from the system clock (ϕ). When use of an external clock is selected, three types of count can be selected: at the rising edge, the falling edge, and both rising and falling edges. 000: Clock input disabled 001: $\phi/8$ internal clock source, counted on the falling edge 010: $\phi/64$ internal clock source, counted on the falling edge 011: $\phi/8192$ internal clock source, counted on the falling edge 100: For channel 0: Counted on TCNT1 overflow signal* For channel 1: Counted on TCNT0 overflow signal* For channel 2: Counted on TCNT3 overflow signal* For channel 3: Counted on TCNT2 overflow signal* 101: External clock source, counted at rising edge 110: External clock source, counted at falling edge 111: External clock source, counted at both rising and falling edges
0	CKS0	0	R/W	

Note: * If the count input of channel 0 (channel 2) is the TCNT1 (TCNT3) overflow signal and that of channel 1 (channel 3) is the TCNT1 (TCNT3) compare-match signal, no incrementing clock will be generated. Do not use this setting.

11.3.5 Timer Control/Status Registers (TCSR)

TCSR indicates status flags and controls compare-match output.

- TCSR_0

Bit	Bit Name	Initial Value	R/W	Description
7	CMFB	0	R/(W)*	Compare-Match Flag B [Setting condition] <ul style="list-style-type: none"> • When TCNT = TCORB [Clearing conditions] <ul style="list-style-type: none"> • Read CMFB when CMFB = 1, then write 0 in CMFB. • DTC is activated by the CMIB interrupt and the DISEL bit = 0 in MRB of TDC.
6	CMFA	0	R/(W)*	Compare-match Flag A [Setting condition] <ul style="list-style-type: none"> • When TCNT = TCORA [Clearing conditions] <ul style="list-style-type: none"> • Read CMFA when CMFA = 1, then write 0 in CMFA. • DTC is activated by the CMIA interrupt and DISEL bit = 0 in MRB of DTC.
5	OVF	0	R/(W)*	Timer Overflow Flag [Setting condition] <ul style="list-style-type: none"> • When TCNT overflows from H'FF to H'00 [Clearing condition] <ul style="list-style-type: none"> • Read OVF when OVF = 1, then write 0 in OVF
4	ADTE	0	R/W	A/D Trigger Enable Enables or disables A/D converter start requests by compare-match A. 0: A/D converter start requests by compare-match A are disabled 1: A/D converter start requests by compare-match A are enabled

Bit	Bit Name	Initial Value	R/W	Description
3	OS3	0	R/W	Output Select 3 and 2
2	OS2	0	R/W	These bits specify how the timer output level is to be changed by a compare-match B of TCORB and TCNT. 00: No change when compare-match B occurs 01: 0 is output when compare-match B occurs 10: 1 is output when compare-match B occurs 11: Output is inverted when compare-match B occurs (toggle output)
1	OS1	0	R/W	Output Select 1 and 0
0	OS0	0	R/W	These bits specify how the timer output level is to be changed by a compare-match A of TCORA and TCNT. 00: No change when compare-match A occurs 01: 0 is output when compare-match A occurs 10: 1 is output when compare-match A occurs 11: Output is inverted when compare-match A occurs (toggle output)

Note: * Only a 0 can be written to this bit, to clear the flag

- TCSR_3 and TCSR_1

Bit	Bit Name	Initial Value	R/W	Description
7	CMFB	0	R/(W)*	Compare-Match Flag B [Setting condition] <ul style="list-style-type: none"> When TCNT = TCORB [Clearing conditions] <ul style="list-style-type: none"> Read CMFB when CMFB = 1, then write 0 in CMFB DTC is activated by the CMIB interrupt and the DISEL bit = 0 in MRB of DTC.
6	CMFA	0	R/(W)*	Compare-match Flag A [Setting condition] <ul style="list-style-type: none"> When TCNT = TCORA [Clearing conditions] <ul style="list-style-type: none"> Read CMFA when CMFA = 1, then write 0 in CMFA DTC is activated by the CMIA interrupt and the DISEL bit = 0 in MRB of DTC.
5	OVF	0	R/(W)*	Timer Overflow Flag [Setting condition] <ul style="list-style-type: none"> When TCNT overflows from H'FF to H'00 [Clearing condition] <ul style="list-style-type: none"> Read OVF when OVF = 1, then write 0 in OVF
4	—	1	—	Reserved This bit is always read as 1 and cannot be modified.
3	OS3	0	R/W	Output Select 3 and 2
2	OS2	0	R/W	These bits specify how the timer output level is to be changed by a compare-match B of TCORB and TCNT. 00: No change when compare-match B occurs 01: 0 is output when compare-match B occurs 10: 1 is output when compare-match B occurs 11: Output is inverted when compare-match B occurs (toggle output)

Bit	Bit Name	Initial Value	R/W	Description
1	OS1	0	R/W	Output Select 1 and 0
0	OS0	0	R/W	These bits specify how the timer output level is to be changed by a compare-match A of TCORA and TCNT. 00: No change when compare-match A occurs 01: 0 is output when compare-match A occurs 10: 1 is output when compare-match A occurs 11: Output is inverted when compare-match A occurs (toggle output)

Note: * Only a 0 can be written to this bit, to clear the flag.

- TCSR_2

Bit	Bit Name	Initial Value	R/W	Description
7	CMFB	0	R/(W)*	Compare-Match Flag B [Setting condition] <ul style="list-style-type: none"> • When TCNT = TCORB [Clearing conditions] <ul style="list-style-type: none"> • Read CMFB when CMFB = 1, then write 0 in CMFB • DTC is activated by the CMIB interrupt and the DISEL bit = 0 in MRB of DTC.
6	CMFA	0	R/(W)*	Compare-match Flag A [Setting condition] When TCNT = TCORA [Clearing conditions] <ul style="list-style-type: none"> • Read CMFA when CMFA = 1, then write 0 in CMFA • DTC is activated by the CMIA interrupt and the DISEL bit = 0 in MRB of DTC.
5	OVF	0	R/(W)*	Timer Overflow Flag [Setting condition] <ul style="list-style-type: none"> • When TCNT overflows from H'FF to H'00 [Clearing condition] <ul style="list-style-type: none"> • Read OVF when OVF = 1, then write 0 in OVF

Bit	Bit Name	Initial Value	R/W	Description
4	—	0	R/W	Reserved This bit is a readable/writable bit, but the write value should always be 0.
3	OS3	0	R/W	Output Select 3 and 2
2	OS2	0	R/W	These bits specify how the timer output level is to be changed by a compare-match B of TCORB and TCNT. 00: No change when compare-match B occurs 01: 0 is output when compare-match B occurs 10: 1 is output when compare-match B occurs 11: Output is inverted when compare-match B occurs (toggle output)
1	OS1	0	R/W	Output Select 1 and 0
0	OS0	0	R/W	These bits specify how the timer output level is to be changed by a compare-match A of TCORA and TCNT. 00: No change when compare-match A occurs 01: 0 is output when compare-match A occurs 10: 1 is output when compare-match A occurs 11: Output is inverted when compare-match A occurs (toggle output)

Note: * Only a 0 can be written to this bit, to clear the flag.

11.4 Operation

11.4.1 Pulse Output

Figure 11.2 shows an example of arbitrary duty cycle pulse output.

1. Set TCR in CCR1 to 0 and CCLR0 to 1 to clear TCNT by a TCORA compare-match.
2. Set OS3 to OS0 bits in TCSR to B'0110 to output 1 by a compare-match A and 0 by compare-match B.

By the above settings, waveforms with the cycle of TCORA and the pulse width of TCRB can be output without software intervention.

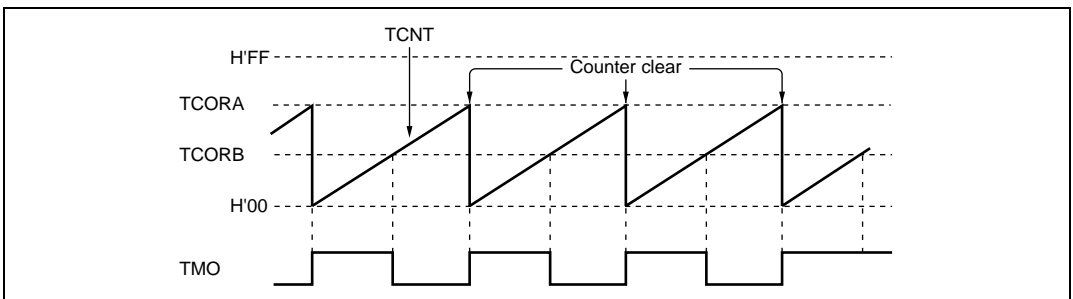

Figure 11.2 Example of Pulse Output

11.5 Operation Timing

11.5.1 TCNT Incrementation Timing

Figure 11.3 shows the TCNT count timing with internal clock source. Figure 11.4 shows the TCNT incrementation timing with external clock source. The pulse width of the external clock for incrementation at signal edge must be at least 1.5 system clock (ϕ) periods, and at least 2.5 states for incrementation at both edges. The counter will not increment correctly if the pulse width is less than these values.

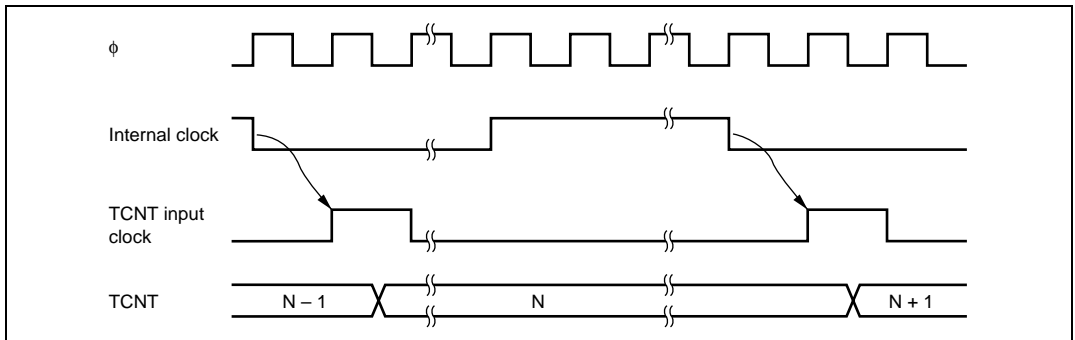

Figure 11.3 Count Timing for Internal Clock Input

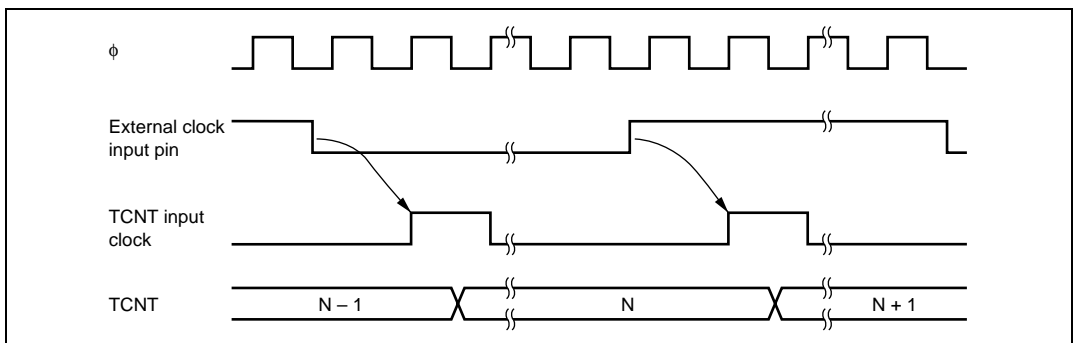

Figure 11.4 Count Timing for External Clock Input

11.5.2 Timing of CMFA and CMFB Setting When a Compare-Match Occurs

The CMFA and CMFB flags in TCSR are set to 1 by a compare-match signal generated when the TCOR and TCNT values match. The compare-match signal is generated at the last state in which the match is true, just before the timer counter is updated. Therefore, when TCOR and TCNT match, the compare-match signal is not generated until the next incrementation clock input. Figure 11.5 shows the timing of CMF flag setting.

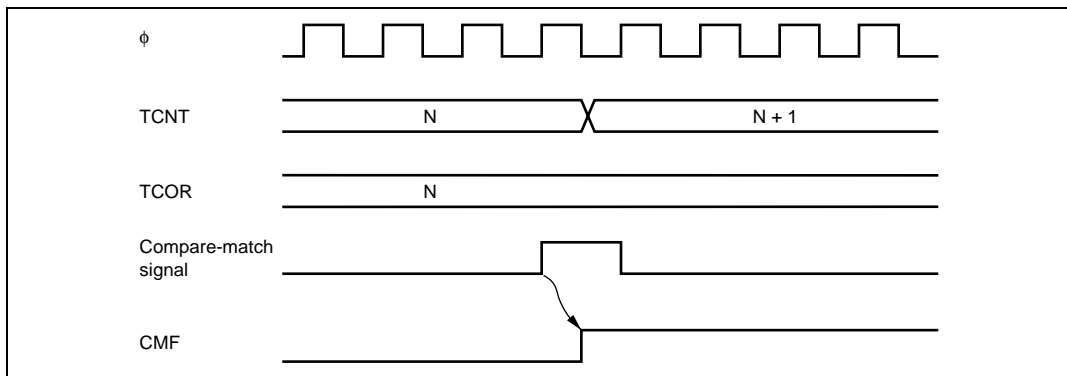

Figure 11.5 Timing of CMF Setting

11.5.3 Timing of Timer Output When a Compare-Match Occurs

When a compare-match occurs, the timer output changes as specified by the output select bits (OS3 to OS0) in TCSR. Figure 11.6 shows the timing when the output is set to toggle at compare-match A.

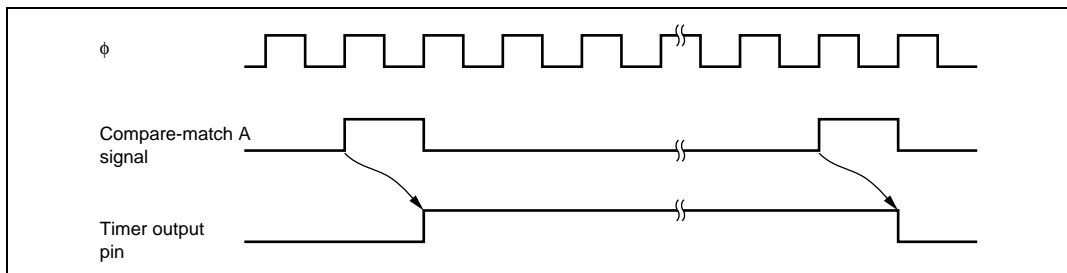

Figure 11.6 Timing of Timer Output

11.5.4 Timing of Compare-Match Clear When a Compare-Match Occurs

TCNT is cleared when compare-match A or B occurs, depending on the setting of the CCLR1 and CCLR0 bits in TCR. Figure 11.7 shows the timing of this operation.

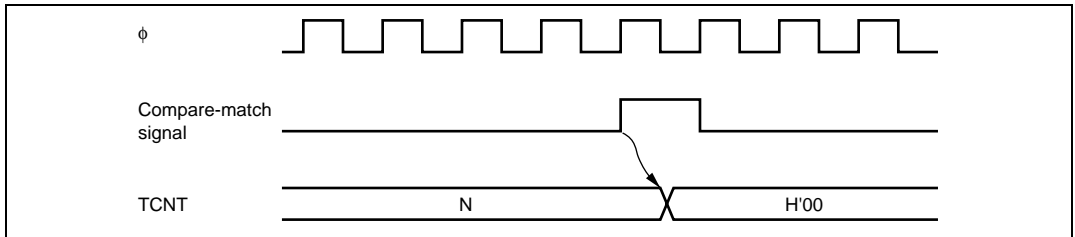

Figure 11.7 Timing of Compare-Match Clear

11.5.5 TCNT External Reset Timing

TCNT is cleared at the rising edge of an external reset input, depending on the settings of the CCLR1 and CCLR0 bits in TCR. The width of the clearing pulse must be at least 1.5 states. Figure 11.8 shows the timing of this operation.

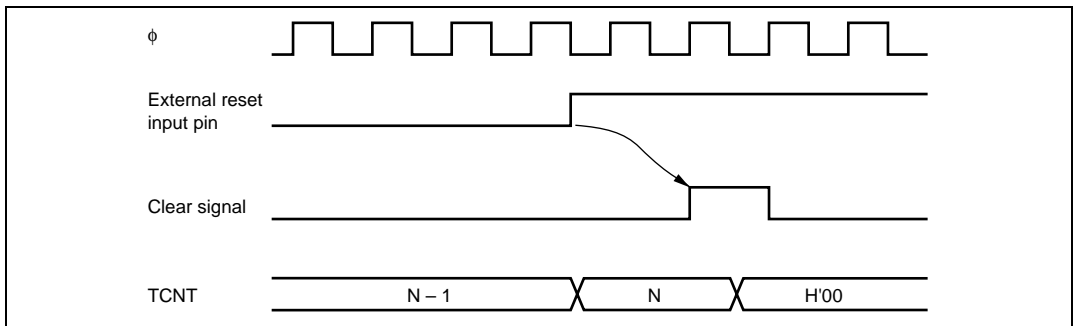

Figure 11.8 Timing of Clearing by External Reset Input

11.5.6 Timing of Overflow Flag (OVF) Setting

OVF in TCSR is set to 1 when the timer count overflows (changes from H'FF to H'00). Figure 11.9 shows the timing of this operation.

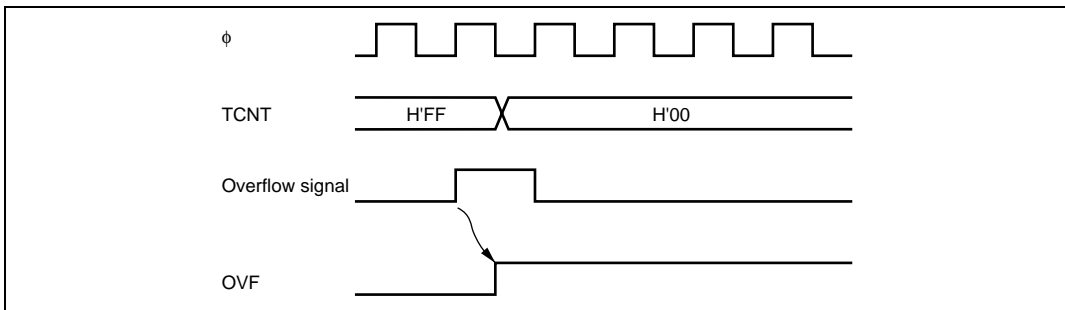

Figure 11.9 Timing of OVF Setting

11.6 Operation with Cascaded Connection

If bits CKS2 to CKS0 in one of TCR_1 and TCR_0, or TCR_3 and TCR_2 are set to B'100, the 8-bit timers of the two channels are cascaded. With this configuration, a single 16-bit timer can be used (16-bit timer mode) or compare-matches of 8-bit channel 0 (Channel 2) can be counted by the timer of channel 1 (Channel 3) (compare-match count mode). In the case that channel 0 is connected to channel 1 in cascade, the timer operates as described below.

11.6.1 16-Bit Count Mode

When bits CKS2 to CKS0 in TCR_0 are set to B'100, the timer functions as a single 16-bit timer with channel 0 occupying the upper 8 bits and channel 1 occupying the lower 8 bits.

- Setting of compare-match flags
 - The CMF flag in TCSR_0 is set to 1 when a 16-bit compare-match occurs.
 - The CMF flag in TCSR_1 is set to 1 when a lower 8-bit compare-match occurs.
- Counter clear specification
 - If the CCLR1 and CCLR0 bits in TCR_0 have been set for counter clear at compare-match, the 16-bit counter (TCNT_1 and TCNT_0 together) is cleared when a 16-bit compare-match occurs. The 16-bit counter (TCNT_1 and TCNT_0 together) is cleared even if counter clear by the TMRI01 pin has also been set.
 - The settings of the CCLR1 and CCLR0 bits in TCR_1 are ignored. The lower 8 bits cannot be cleared independently.
- Pin output
 - Control of output from the TMO0 pin by bits OS3 to OS0 in TCSR_0 is in accordance with the 16-bit compare-match conditions.
 - Control of output from the TMO1 pin by bits OS3 to OS0 in TCSR_1 is in accordance with the lower 8-bit compare-match conditions.

11.6.2 Compare-Match Count Mode

When bits CKS2 to CKS0 in TCR_1 are B'100, TCNT_1 counts compare-match A for channel 0. Channels 0 and 1 are controlled independently. Conditions such as setting of the CMF flag, generation of interrupts, output from the TMO pin, and counter clearing are in accordance with the settings for each channel.

11.7 Interrupt Sources

11.7.1 Interrupt Sources and DTC Activation

The 8-bit timer can generate three types of interrupt: CMIA, CMIB, and OVI. Table 11.2 shows the interrupt sources and priority. Each interrupt source can be enabled or disabled independently by interrupt enable bits in TCR. Independent signals are sent to the interrupt controller for each interrupt. It is also possible to activate the DTC by means of CMIA and CMIB interrupts.

Table 11.2 8-Bit Timer Interrupt Sources

Interrupt source	Description	Flag	DTC Activation	Interrupt Priority	
CMIA0	TCORA_0 compare-match	CMFA	Possible	High	
CMIB0	TCORB_0 compare-match	CMFB	Possible	↑	
OVI0	TCNT_0 overflow	OVF	Not possible		
CMIA1	TCORA_1 compare-match	CMFA	Possible		
CMIB1	TCORB_1 compare-match	CMFB	Possible		
OVI1	TCNT_1 overflow	OVF	Not possible		
CMIA2	TCORA_2 compare-match	CMFA	Possible		
CMIB2	TCORB_2 compare-match	CMFB	Possible		
OVI2	TCNT_2 overflow	OVF	Not possible		
CMIA3	TCORA_3 compare-match	CMFA	Possible		
CMIB3	TCORB_3 compare-match	CMFB	Possible		
OVI3	TCNT_3 overflow	OVF	Not possible		Low

11.7.2 A/D Converter Activation

The A/D converter can be activated only by channel 0 compare match A.

If the ADTE bit in TCSR0 is set to 1 when the CMFA flag is set to 1 by the occurrence of channel 0 compare match A, a request to start A/D conversion is sent to the A/D converter. If the 8-bit timer conversion start trigger has been selected on the A/D converter side at this time, A/D conversion is started.

11.8 Usage Notes

11.8.1 Conflict between TCNT Write and Clear

If a timer counter clock pulse is generated during the T_2 state of a TCNT write cycle, the clear takes priority, so that the counter is cleared and the write is not performed. Figure 11.10 shows this operation.

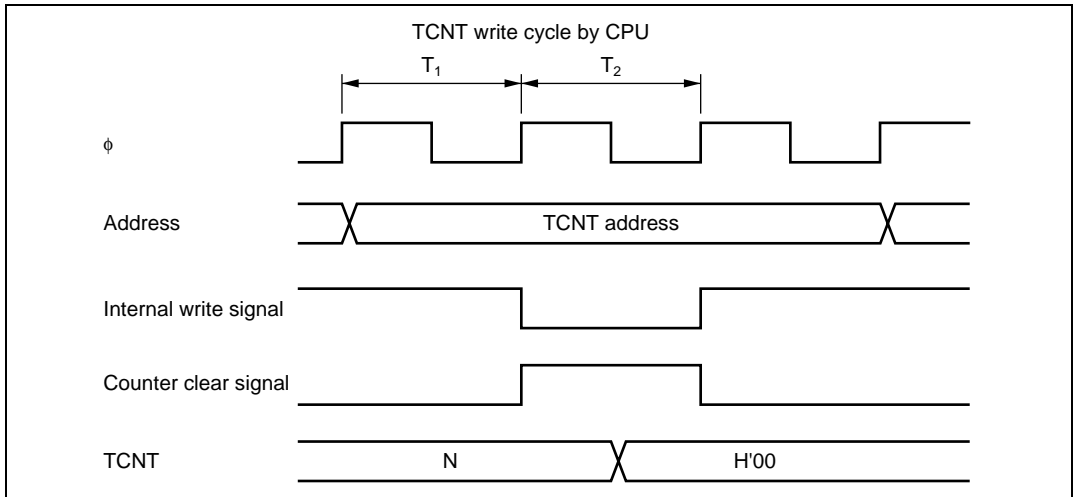

Figure 11.10 Conflict between TCNT Write and Clear

11.8.2 Conflict between TCNT Write and Increment

If a timer counter clock pulse is generated during the T_2 state of a TCNT write cycle, the write takes priority and the counter is not incremented. Figure 11.11 shows this operation.

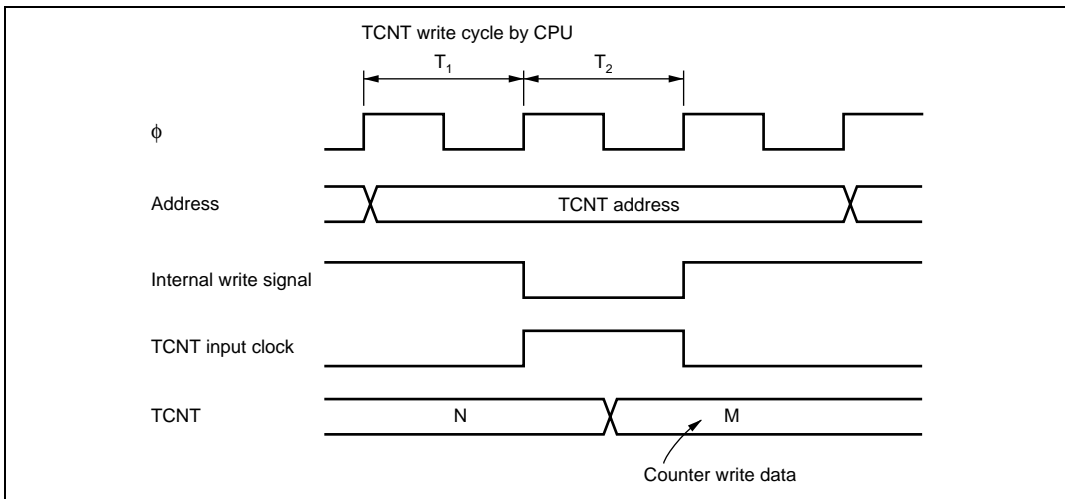

Figure 11.11 Conflict between TCNT Write and Increment

11.8.3 Conflict between TCOR Write and Compare-Match

During the T_2 state of a TCOR write cycle, the TCOR write has priority even if a compare-match occurs and the compare-match signal is disabled. Figure 11.12 shows this operation.

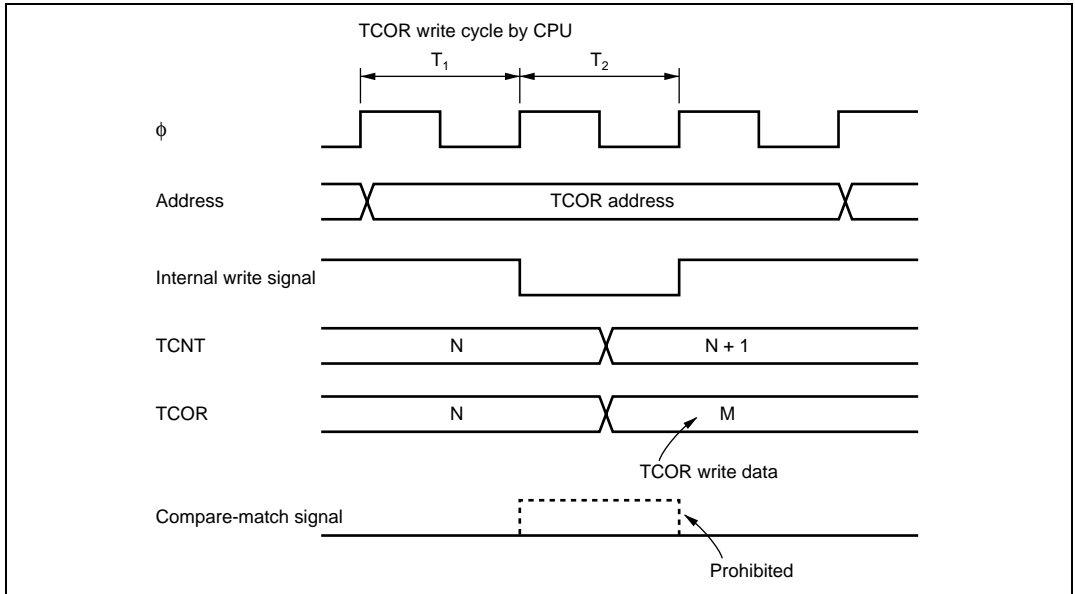

Figure 11.12 Conflict between TCOR Write and Compare-Match

11.8.4 Conflict between Compare-Matches A and B

If compare-matches A and B occur at the same time, the 8-bit timer operates in accordance with the priorities for the output states set for compare-match A and compare-match B, as shown in table 11.3.

Table 11.3 Timer Output Priorities

Output Setting	Priority
Toggle output	High
1 output	↑
0 output	
No change	Low

11.8.5 Switching of Internal Clocks and TCNT Operation

TCNT may increment erroneously when the internal clock is switched over. Table 11.4 shows the relationship between the timing at which the internal clock is switched (by writing to the CKS1 and CKS0 bits) and the TCNT operation.

When the TCNT clock is generated from an internal clock, the falling edge of the internal clock pulse is detected. If clock switching causes a change from high to low level, as shown in no. 3 in table 11.4, a TCNT clock pulse is generated on the assumption that the switchover is a falling edge. This increments TCNT.

Erroneous incrementation can also happen when switching between internal and external clocks.

Table 11.4 Switching of Internal Clock and TCNT Operation

No.	Timing of Switchover by Means of CKS1 and CKS0 Bits	TCNT Clock Operation
1	Switching from low to low ^{*1}	
2	Switching from low to high ^{*2}	

Timing of Switchover by Means of CKS1 and CKS0 Bits

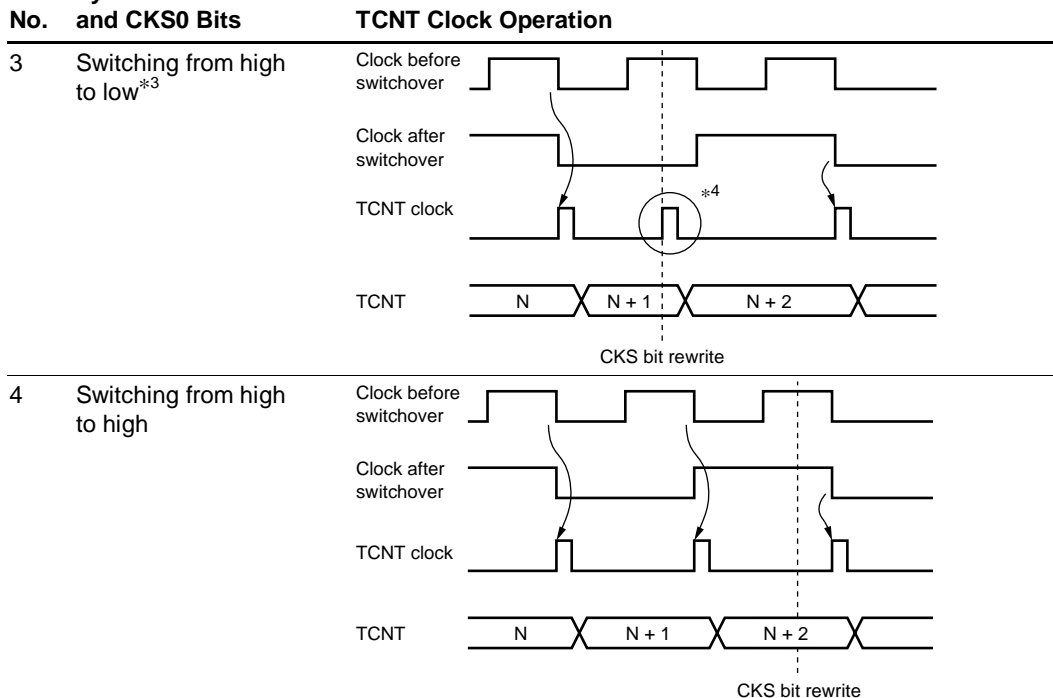

- Notes:
1. Includes switching from low to stop, and from stop to low.
 2. Includes switching from stop to high.
 3. Includes switching from high to stop.
 4. Generated on the assumption that the switchover is a falling edge; TCNT is incremented.

11.8.6 Conflict between Interrupts and Module Stop Mode

If module stop mode is entered when an interrupt has been requested, it will not be possible to clear the CPU interrupt source or the DTC activation source. Interrupts should therefore be disabled before entering module stop mode.

11.8.7 Notes on Cascaded Connection

If 16-bit count mode and compare-match count mode are set simultaneously, the counter stops and does not operate since input clocks of TCNT_1 and TCNT_0 (TCNT_3 and TCNT_2) are not generated. This setting is prohibited.

Section 12 Programmable Pulse Generator (PPG)

The programmable pulse generator provides pulse outputs using the 16-bit timer pulse unit (TPU) as a time base. The PPG pulse outputs are divided into 4-bit groups (group 3 and group 2) that can operate both simultaneously and independently. The block diagram of the PPG is shown in figure 12.1.

12.1 Features

- 8-bit output data
- Two output groups
- Selectable output trigger signals
- Non-overlap mode
- Can operate in tandem with the data transfer controller (DTC)
- Settable inverted output
- Module stop mode can be set

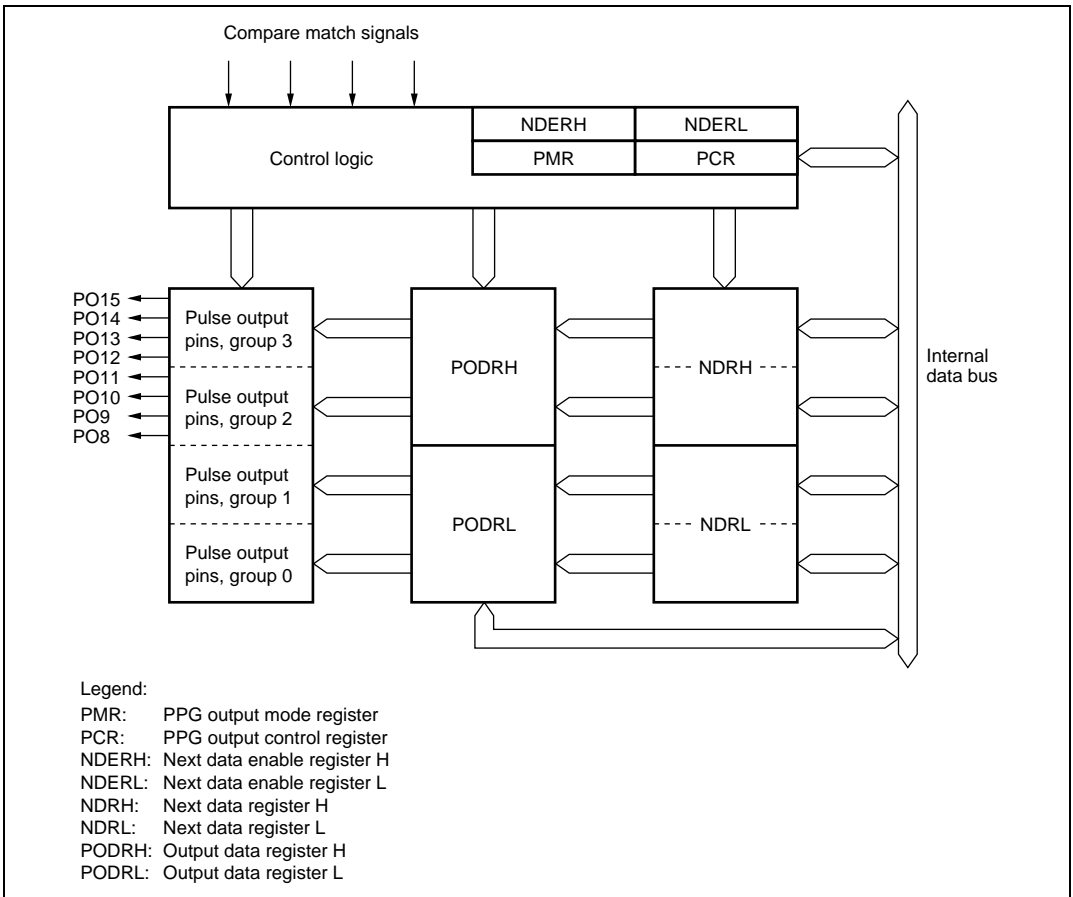

Figure 12.1 Block Diagram of PPG

12.2 Input/Output Pins

Table 12.1 summarizes the pin configuration of the PPG.

Table 12.1 Pin Configuration

Pin Name	I/O	Function
PO15	Output	Group 3 pulse output
PO14	Output	
PO13	Output	
PO12	Output	Group 2 pulse output
PO11	Output	
PO10	Output	
PO9	Output	
PO8	Output	

12.3 Register Descriptions

The PPG has the following registers.

- PPG output control register (PCR)
- PPG output mode register (PMR)
- Next data enable register H (NDERH)
- Next data enable register L (NDERL)
- Output data register H (PODRH)
- Output data register L (PODRL)
- Next data register H (NDRH)
- Next data register L (NDRL)

12.3.1 Next Data Enable Registers H, L (NDERH, NDERL)

NDERH and NDERL are 8-bit readable/writable registers that enable or disable pulse output on a bit-by-bit basis. The corresponding DDR also needs to be set to 1 in order to enable pulse output by the PPG.

- NDERH

Bit	Bit Name	Initial Value	R/W	Description
7	NDER15	0	R/W	Next Data Enable 15 to 8
6	NDER14	0	R/W	When a bit is set to 1 for pulse output by NDRH, the value in the corresponding NDRH bit is transferred to the PODRH bit by the selected output trigger. Values are not transferred from NDRH to PODRH for cleared bits.
5	NDER13	0	R/W	
4	NDER12	0	R/W	
3	NDER11	0	R/W	
2	NDER10	0	R/W	
1	NDER9	0	R/W	
0	NDER8	0	R/W	

- NDERL

Bit	Bit Name	Initial Value	R/W	Description
7	NDER7	0	R/W	Next Data Enable 7 to 0
6	NDER6	0	R/W	When a bit is set to 1 for pulse output by NDRL, the value in the corresponding NDRL bit is transferred to the PODRL bit by the selected output trigger. Values are not transferred from NDRL to PODRL for cleared bits.
5	NDER5	0	R/W	
4	NDER4	0	R/W	
3	NDER3	0	R/W	
2	NDER2	0	R/W	
1	NDER1	0	R/W	
0	NDER0	0	R/W	

12.3.2 Output Data Registers H, L (PODRH, PODRL)

PODRH and PODRL are 8-bit readable/writable registers that store output data for use in pulse output. A bit that has been set for pulse output by NDER is read-only and cannot be modified.

- PODRH

Bit	Bit Name	Initial Value	R/W	Description
7	POD15	0	R/W	Output Data Register 15 to 8
6	POD14	0	R/W	For bits that have been set to pulse output by NDERH, the output trigger transfers NDRH values to this register during PPG operation. While NDERH is set to 1, the CPU cannot write to this register. While NDERH is cleared, the initial output value of the pulse can be set.
5	POD13	0	R/W	
4	POD12	0	R/W	
3	POD11	0	R/W	
2	POD10	0	R/W	
1	POD9	0	R/W	
0	POD8	0	R/W	

- PODRL

Bit	Bit Name	Initial Value	R/W	Description
7	POD7	0	R/W	Output Data Register 7 to 0
6	POD6	0	R/W	For bits which have been set to pulse output by NDERL, the output trigger transfers NDRL values to this register during PPG operation. While NDERL is set to 1, the CPU cannot write to this register. While NDERL is cleared, the initial output value of the pulse can be set.
5	POD5	0	R/W	
4	POD4	0	R/W	
3	POD3	0	R/W	
2	POD2	0	R/W	
1	POD1	0	R/W	
0	POD0	0	R/W	

12.3.3 Next Data Registers H, L (NDRH, NDRL)

NDRH and NDRL are 8-bit readable/writable registers that store the data for the next pulse output. The NDR addresses differ depending on whether pulse output groups have the same output trigger or different output triggers.

- NDRH

If pulse output groups 3 and 2 have the same output trigger, all eight bits are mapped to the same address and can be accessed at one time, as shown below.

Bit	Bit Name	Initial Value	R/W	Description
7	NDR15	0	R/W	Next Data Register 15 to 8
6	NDR14	0	R/W	The register contents are transferred to the corresponding PODRH bits by the output trigger specified with PCR.
5	NDR13	0	R/W	
4	NDR12	0	R/W	
3	NDR11	0	R/W	
2	NDR10	0	R/W	
1	NDR9	0	R/W	
0	NDR8	0	R/W	

If pulse output groups 3 and output pulse groups 2 have different output triggers, the upper 4 bits and the lower 4 bits are mapped to different addresses, as shown below.

Bit	Bit Name	Initial Value	R/W	Description
7	NDR15	0	R/W	Next Data Register 15 to 12
6	NDR14	0	R/W	The register contents are transferred to the corresponding PODRH bits by the output trigger specified with PCR.
5	NDR13	0	R/W	
4	NDR12	0	R/W	
3 to 0	—	All 1	—	
				These bits are always read as 1 and cannot be modified.

Bit	Bit Name	Initial Value	R/W	Description
7 to 4	—	All 1	—	Reserved These bits are always read as 1 and cannot be modified.
3	NDR11	0	R/W	Next Data Register 11 to 8
2	NDR10	0	R/W	The register contents are transferred to the corresponding PODRH bits by the output trigger specified with PCR.
1	NDR9	0	R/W	
0	NDR8	0	R/W	

- NDRL

If pulse output groups 1 and 0 have the same output trigger, all eight bits are mapped to the same address and can be accessed at one time, as shown below.

Bit	Bit Name	Initial Value	R/W	Description
7	NDR7	0	R/W	Next Data Register 7 to 0
6	NDR6	0	R/W	The register contents are transferred to the corresponding PODRL bits by the output trigger specified with PCR.
5	NDR5	0	R/W	
4	NDR4	0	R/W	
3	NDR3	0	R/W	
2	NDR2	0	R/W	
1	NDR1	0	R/W	
0	NDR0	0	R/W	

If pulse output groups 1 and output pulse groups 0 have different output triggers, upper 4 bits and lower 4 bits are mapped to the different addresses as shown below.

Bit	Bit Name	Initial Value	R/W	Description
7	NDR7	0	R/W	Next Data Register 7 to 4
6	NDR6	0	R/W	The register contents are transferred to the corresponding PODRL bits by the output trigger specified with PCR.
5	NDR5	0	R/W	
4	NDR4	0	R/W	
3 to 0	—	All 1	—	Reserved These bits are always read as 1 and cannot be modified.

Bit	Bit Name	Initial Value	R/W	Description
7 to 4	—	All 1	—	Reserved These bits are always read as 1 and cannot be modified.
3	NDR3	0	R/W	Next Data Register 3 to 0
2	NDR2	0	R/W	The register contents are transferred to the corresponding PODRL bits by the output trigger specified with PCR.
1	NDR1	0	R/W	
0	NDR0	0	R/W	

12.3.4 PPG Output Control Register (PCR)

PCR is an 8-bit readable/writable register that selects output trigger signals on a group-by-group basis. For details on output trigger selection, refer to section 12.3.5, PPG Output Mode Register (PMR).

Bit	Bit Name	Initial Value	R/W	Description
7	G3CMS1	1	R/W	Group 3 Compare Match Select 1 and 0
6	G3CMS0	1	R/W	Select output trigger of pulse output group 3. 00: Compare match in TPU channel 0 01: Compare match in TPU channel 1 10: Compare match in TPU channel 2 11: Compare match in TPU channel 3
5	G2CMS1	1	R/W	Group 2 Compare Match Select 1 and 0
4	G2CMS0	1	R/W	Select output trigger of pulse output group 2. 00: Compare match in TPC channel 0 01: Compare match in TPC channel 1 10: Compare match in TPC channel 2 11: Compare match in TPC channel 3
3	G1CMS1	1	R/W	Reserved
2	G1CMS0	1	R/W	
1	G0CMS1	1	R/W	Reserved
0	G0CMS0	1	R/W	

12.3.5 PPG Output Mode Register (PMR)

The PMR is an 8-bit readable/writable register that selects the pulse output mode of the PPG for each group. If inverted output is selected, a low-level pulse is output when PODRH is 1 and a high-level pulse is output when PODRH is 0. If non-overlapping operation is selected, PPG updates its output values on compare match A or B of the TPU that becomes the output trigger. For details, refer to section 12.4.5, Non-Overlapping Pulse Output.

Bit	Bit Name	Initial Value	R/W	Description
7	G3INV	1	R/W	Group 3 Inversion Selects direct output or inverted output for pulse output group 3. 0: Inverted output 1: Direct output
6	G2INV	1	R/W	Group 2 Inversion Selects direct output or inverted output for pulse output group 2. 0: Inverted output 1: Direct output
5, 4	—	All 1	R/W	Reserved
3	G3NOV	0	R/W	Group 3 Non-Overlap Selects normal or non-overlapping operation for pulse output group 3. 0: Normal operation (output values updated at compare match A in the selected TPU channel) 1: Non-overlapping operation (output values at compare match A or B in the selected TPU channel)
2	G2NOV	0	R/W	Group 2 Non-Overlap Selects normal or non-overlapping operation for pulse output group 2. 0: Normal operation (output values updated at compare match A in the selected TPU channel) 1: Non-overlapping operation (output values at compare match A or B in the selected TPU channel)
1, 0	—	All 0	R/W	Reserved

12.4 Operation

12.4.1 Overview

Figure 12.2 shows a block diagram of the PPG. PPG pulse output is enabled when the corresponding bits in P1DDR and NDER are set to 1. An initial output value is determined by its corresponding PODR initial setting. When the compare match event specified by PCR occurs, the corresponding NDR bit contents are transferred to PODR to update the output values.

The sequential output of up to 8 bits of data is possible by writing new output data to NDR before the next compare match.

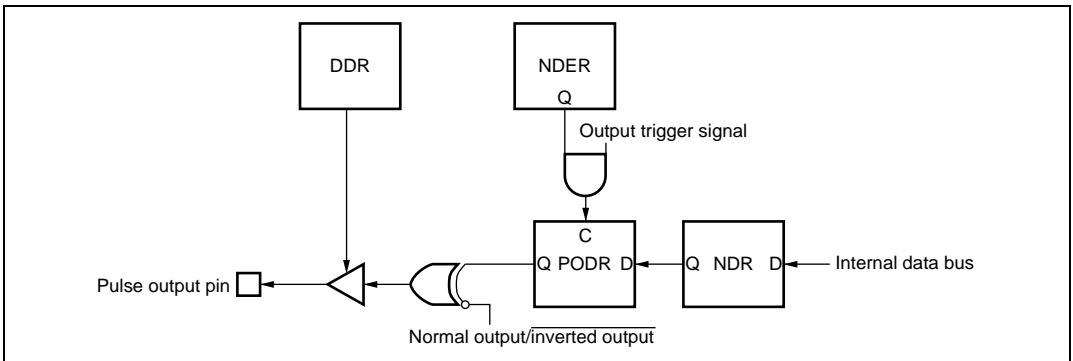

Figure 12.2 PPG Output Operation

12.4.2 Output Timing

If pulse output is enabled, the contents of NDR contents are transferred to PODR and output when the specified compare match event occurs. Figure 12.3 shows the timing of these operations for the case of normal output in groups 3 and 2, triggered by compare match A.

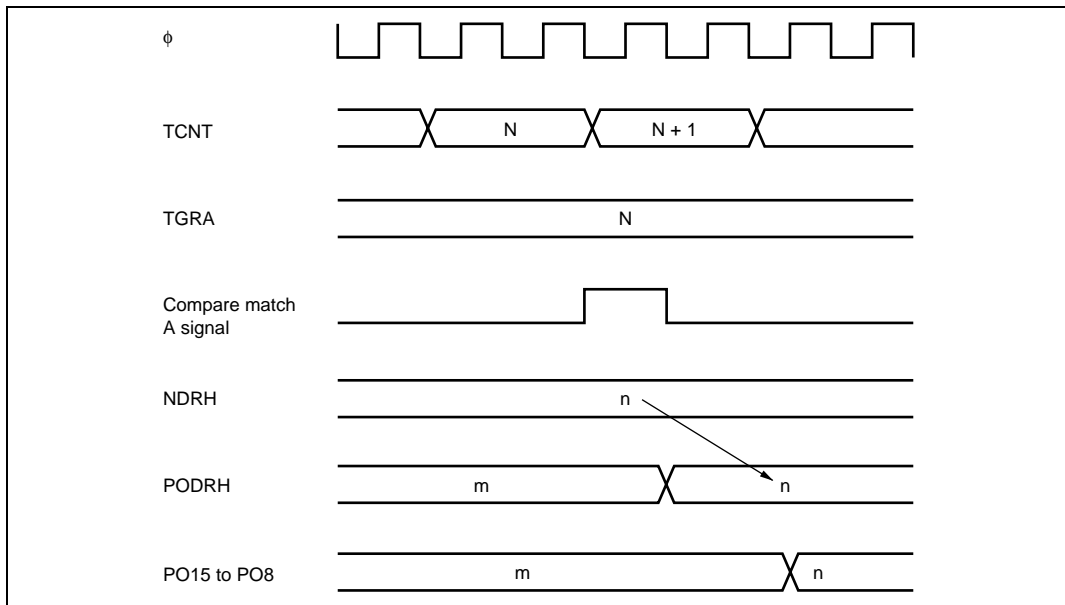

Figure 12.3 Timing of Transfer and Output of NDR Contents (Example)

12.4.3 Sample Setup Procedure for Normal Pulse Output

Figure 12.4 shows a sample procedure for setting up normal pulse output.

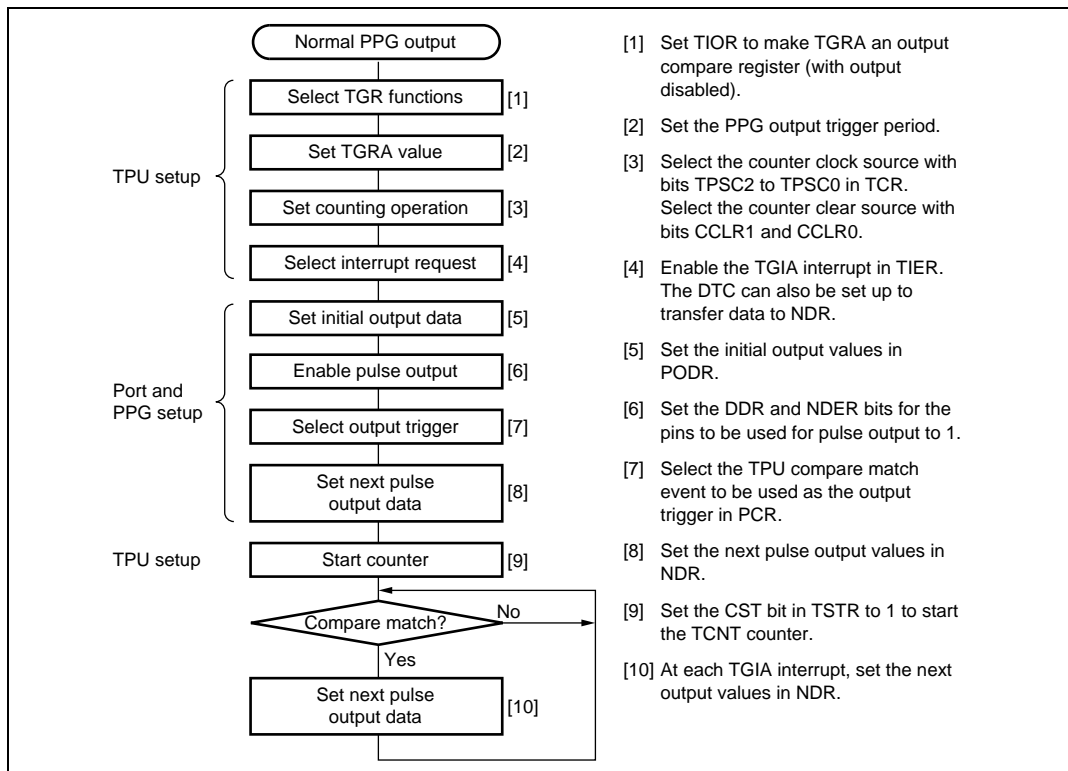

Figure 12.4 Setup Procedure for Normal Pulse Output (Example)

12.4.4 Example of Normal Pulse Output (Example of Five-Phase Pulse Output)

Figure 12.5 shows an example in which pulse output is used for cyclic five-phase pulse output.

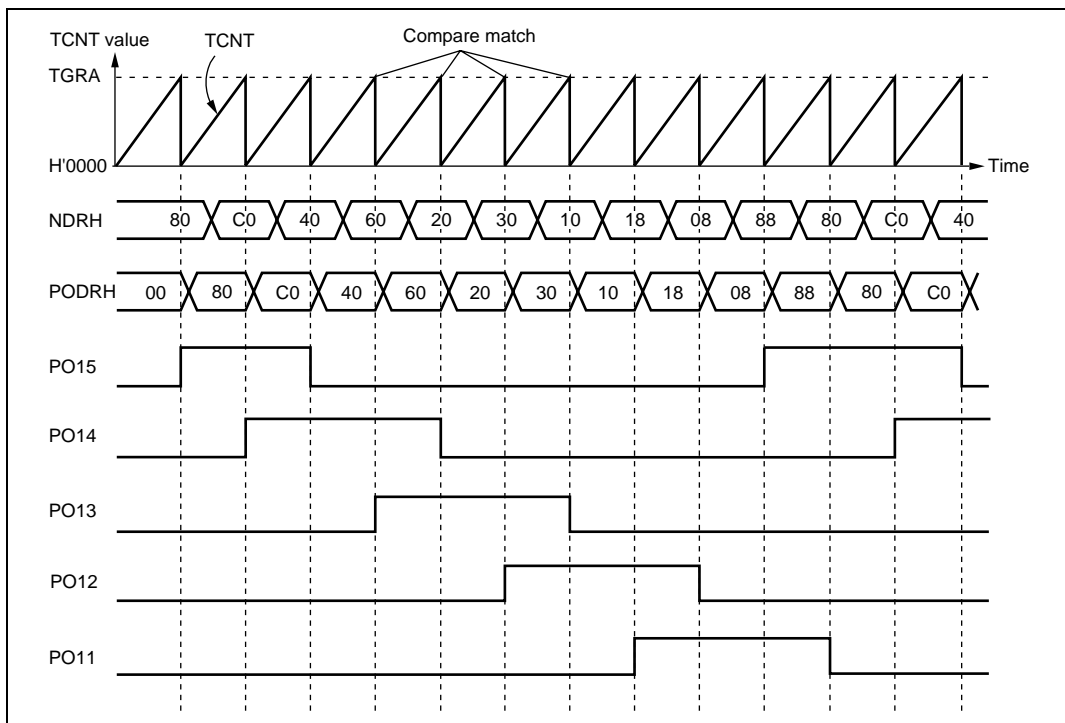

Figure 12.5 Normal Pulse Output Example (Five-Phase Pulse Output)

1. Set up TGRA of the TPU that is used as the output trigger to be an output compare register. Set a frequency in TGRA so the counter will be cleared on compare match A. Set the TGIEA bit of TIER to 1 to enable the compare match/input capture A (TGIA) interrupt.
2. Write H'F8 in P1DDR and NDRH, and set the G3CMS1, G3CMS0, G2CMS1, and G2CMS0 bits in PCR to select compare match in the TPU channel set up in the previous step to be the output trigger. Write output data H'80 in NDRH.
3. When compare match A occurs, the NDRH contents are transferred to PODRH and output. The TGIA interrupt handling routine writes the next output data (H'C0) in NDRH.
4. Five-phase overlapping pulse output (one or two phases active at a time) can be obtained subsequently by writing H'40, H'60, H'20, H'30, H'10, H'18, H'08, H'88... at successive TGIA interrupts. If the DTC is set for activation by this interrupt, pulse output can be obtained without imposing a load on the CPU.

12.4.5 Non-Overlapping Pulse Output

During non-overlapping operation, transfer from NDR to PODR is performed as follows:

- NDR bits are always transferred on PODR bits on compare match A.
- On compare match B, NDR bits are transferred only if their value is 0. Bits are not transferred if their value is 1.

Figure 12.6 illustrates the non-overlapping pulse output operation.

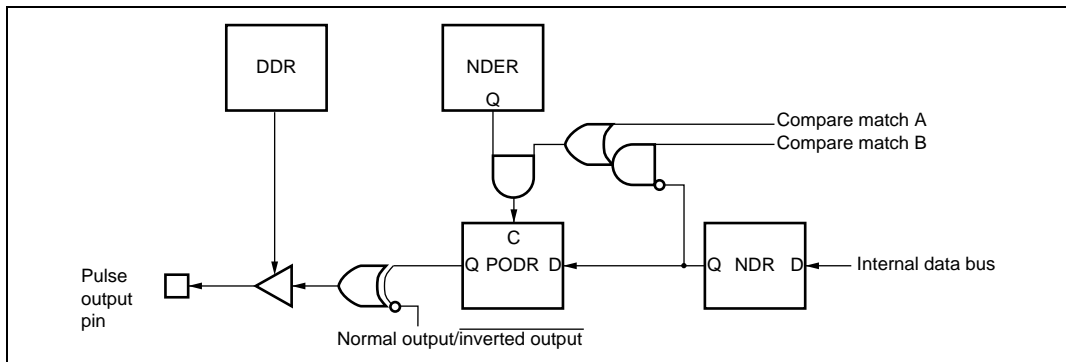

Figure 12.6 Non-Overlapping Pulse Output

Therefore, 0 data can be transferred ahead of 1 data by making compare match B occur before compare match A. The NDR contents should not be altered during the interval between compare match B and compare match A (the non-overlap margin).

This can be accomplished by having the TGIA interrupt handling routine write the next data in NDR, or by having the TGIA interrupt activate the DTC. Note, however, that the next data must be written before the next compare match B occurs.

Figure 12.7 shows the timing of this operation.

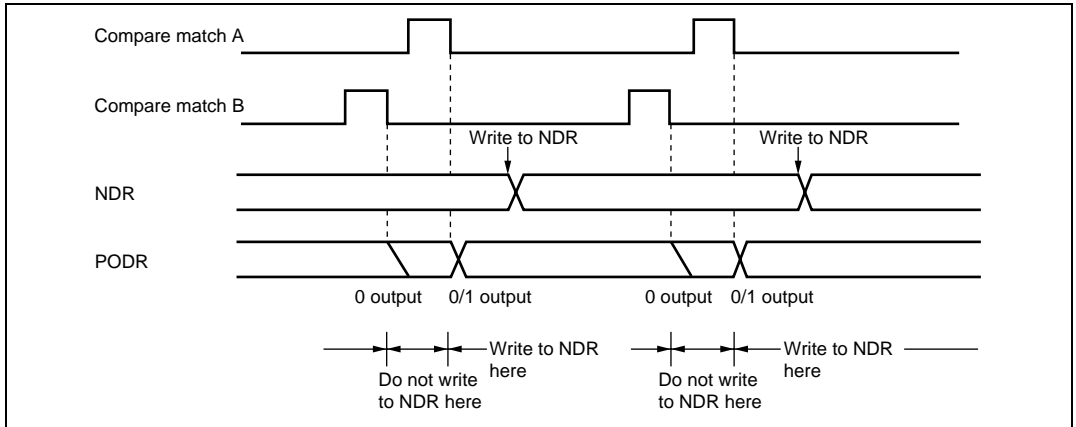

Figure 12.7 Non-Overlapping Operation and NDR Write Timing

12.4.6 Sample Setup Procedure for Non-Overlapping Pulse Output

Figure 12.8 shows a sample procedure for setting up non-overlapping pulse output.

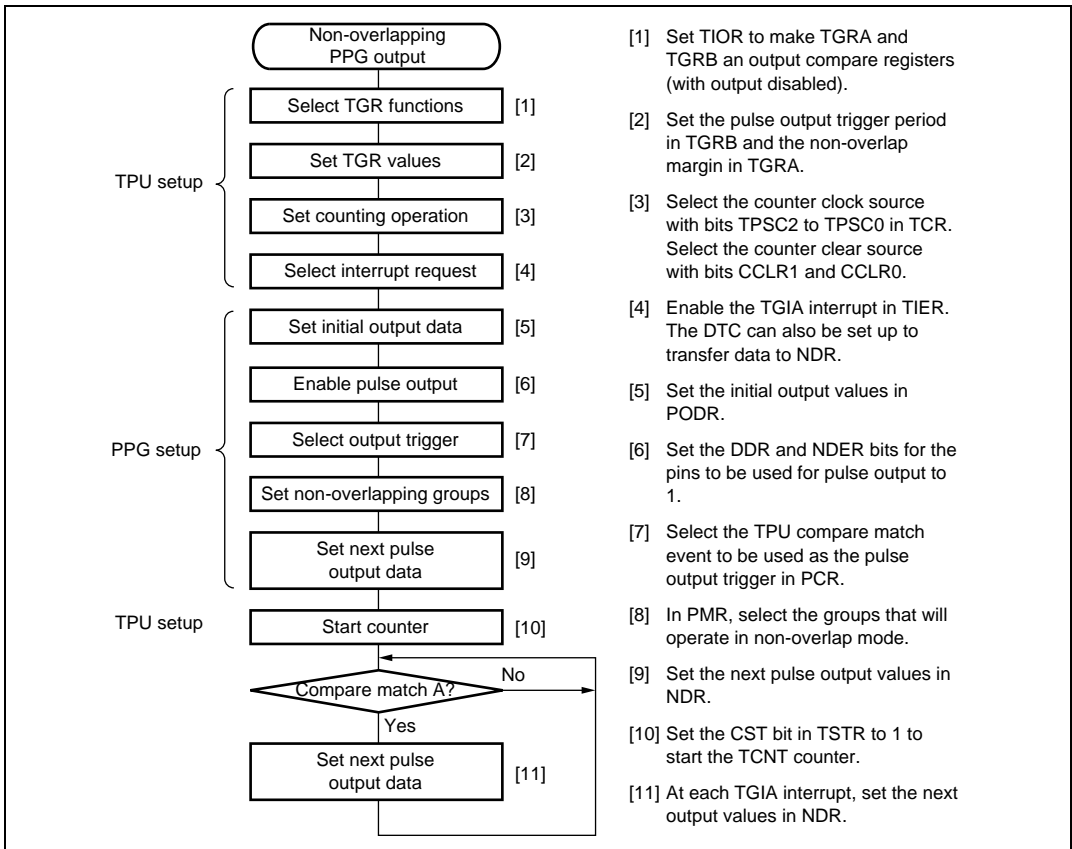

Figure 12.8 Setup Procedure for Non-Overlapping Pulse Output (Example)

12.4.7 Example of Non-Overlapping Pulse Output (Example of Four-Phase Complementary Non-Overlapping Output)

Figure 12.9 shows an example in which pulse output is used for four-phase complementary non-overlapping pulse output.

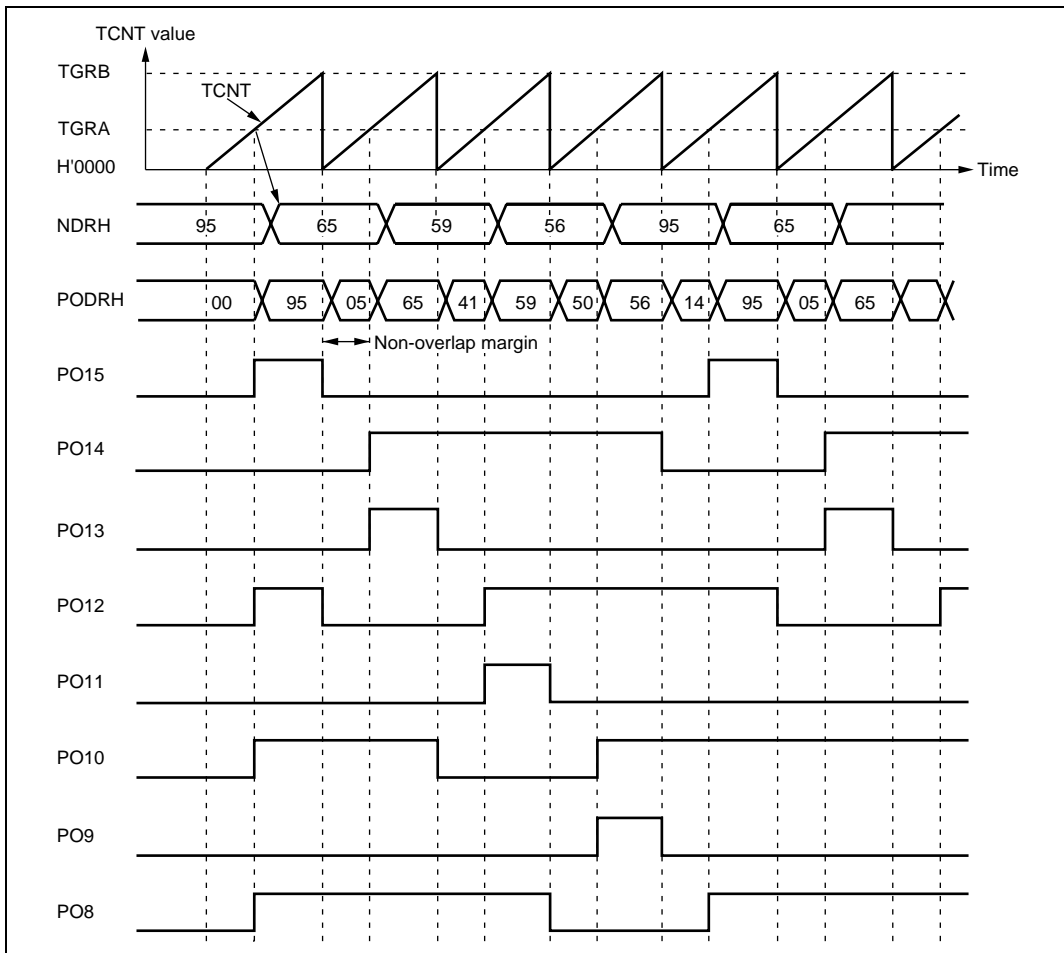

Figure 12.9 Non-Overlapping Pulse Output Example (Four-Phase Complementary)

1. Set up the TPU channel to be used as the output trigger channel such that TGRA and TGRB are output compare registers. Set the trigger period in TGRB and the non-overlap margin in TGRA, and set the counter to be cleared on compare match B. Set the TGIEA bit in TIER to 1 to enable the TGIA interrupt.
2. Write H'FF in P1DDR and NDERH, and set the G3CMS1, G3CMS0, G2CMS1, and G2CMS0 bits in PCR to select compare match in the TPU channel set up in the previous step to be the output trigger. Set the G3NOV and G2NOV bits in PMR to 1 to select non-overlapping output. Write output data H'95 in NDRH.
3. The timer counter in the TPU channel starts. When a compare match with TGRB occurs, outputs change from 1 to 0. When a compare match with TGRA occurs, outputs change from 0 to 1 (the change from 0 to 1 is delayed by the value set in TGRA). The TGIA interrupt handling routine writes the next output data (H'65) in NDRH.
4. Four-phase complementary non-overlapping pulse output can be obtained subsequently by writing H'59, H'56, H'95, ... at successive TGIA interrupts. If the DTC is set for activation by this interrupt, pulse output can be obtained without imposing a load on the CPU.

12.4.8 Inverted Pulse Output

If the G3INV, G2INV, G1INV, and G0INV bits in PMR are cleared to 0, values that are the inverse of the PODR contents can be output.

Figure 12.10 shows the outputs when G3INV and G2INV are cleared to 0, in addition to the settings of figure 12.9.

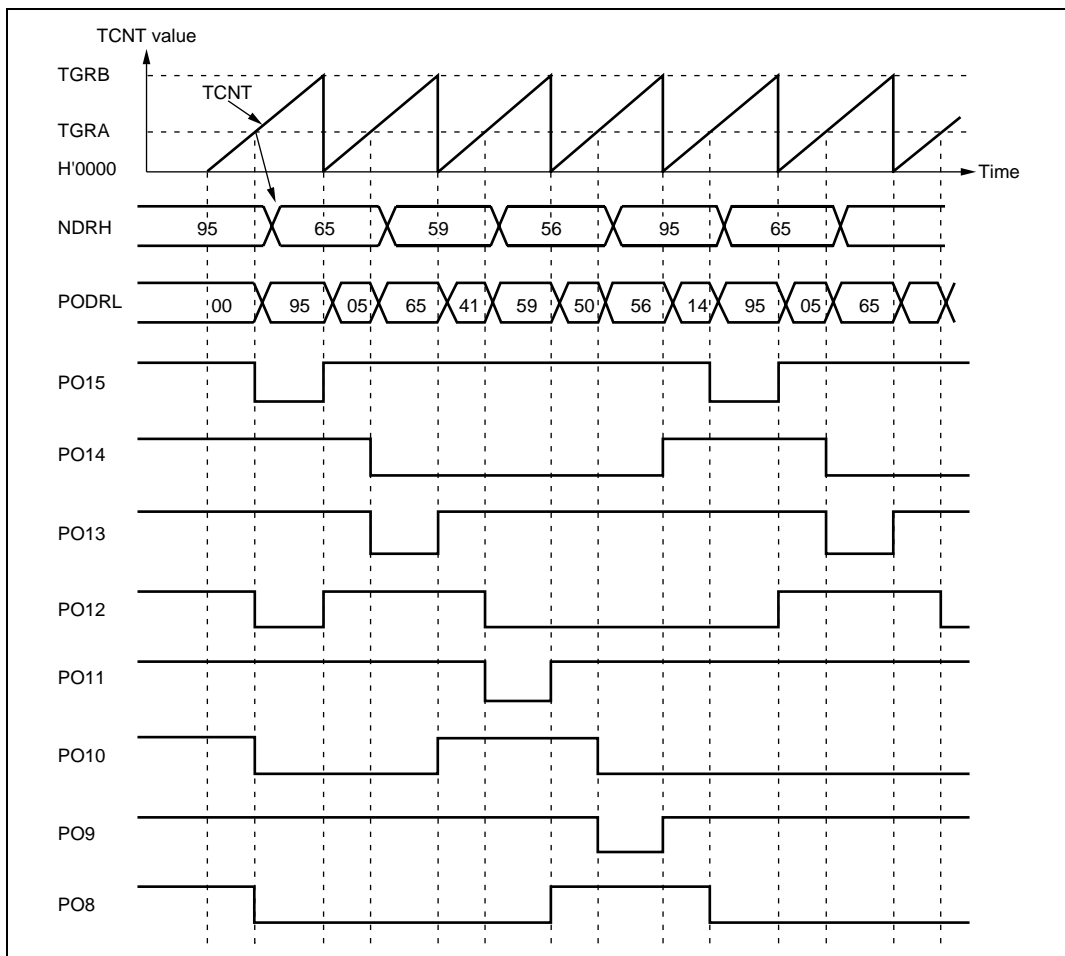

Figure 12.10 Inverted Pulse Output (Example)

12.4.9 Pulse Output Triggered by Input Capture

Pulse output can be triggered by TPU input capture as well as by compare match. If TGRA functions as an input capture register in the TPU channel selected by PCR, pulse output will be triggered by the input capture signal.

Figure 12.11 shows the timing of this output.

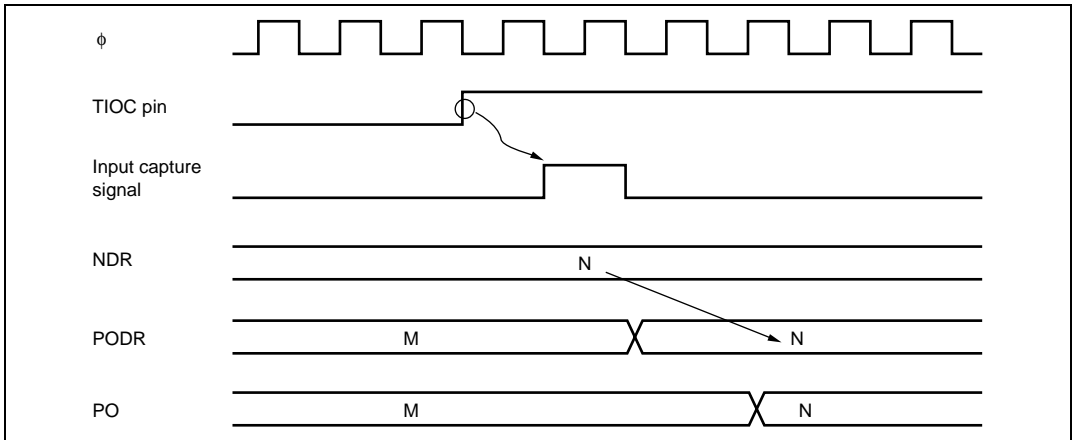

Figure 12.11 Pulse Output Triggered by Input Capture (Example)

12.5 Usage Notes

12.5.1 Module Stop Mode Setting

PPG operation can be disabled or enabled using the module stop control register. The initial setting is for PPG operation to be halted. Register access is enabled by clearing module stop mode. For details, refer to section 21, Power-Down Modes.

12.5.2 Operation of Pulse Output Pins

Pins PO15 to PO8 are also used for other peripheral functions such as the TPU. When output by another peripheral function is enabled, the corresponding pins cannot be used for pulse output. Note, however, that data transfer from NDR bits to PODR bits takes place, regardless of the usage of the pins.

Pin functions should be changed only under conditions in which the output trigger event will not occur.

Section 13 Watchdog Timer

The watchdog timer (WDT) is an 8-bit timer that can generate an internal reset signal for this LSI, if a system crash prevents the CPU from writing to the timer counter, thus allowing it to overflow.

When this watchdog function is not needed, the WDT can be used as an interval timer. In interval timer operation, an interval timer interrupt is generated each time the counter overflows.

The block diagram of the WDT is shown in figure 13.1.

13.1 Features

- Selectable from eight counter input clocks.
- Switchable between watchdog timer mode and interval timer mode

In watchdog timer mode

- If the counter overflows, it is possible to select whether this LSI is internally reset or not.

In interval timer mode

- If the counter overflows, the WDT generates an interval timer interrupt (WOVI).

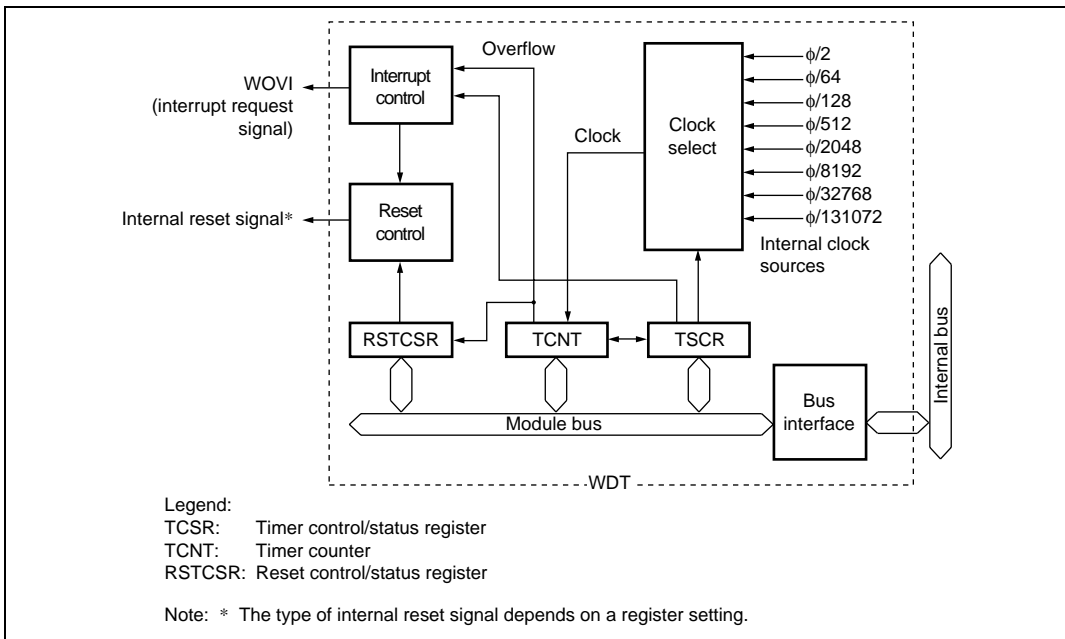

Figure 13.1 Block Diagram of WDT

13.2 Register Descriptions

The WDT has the following three registers. To prevent accidental overwriting, TCSR, TCNT, and RSTCSR have to be written to by a different method to normal registers. For details, refer to section 13.5.1, Notes on Register Access.

- Timer control/status register (TCSR)
- Timer counter (TCNT)
- Reset control/status register (RSTCSR)

13.2.1 Timer Counter (TCNT)

TCNT is an 8-bit readable/writable up-counter. TCNT is initialized to H'00 by a reset, when the TME bit in TCSR is cleared to 0.

13.2.2 Timer Control/Status Register (TCSR)

TCSR is an 8-bit readable/writable register. Its functions include selecting the clock source to be input to TCNT, and selecting the timer mode.

Bit	Bit Name	Initial Value	R/W	Description
7	OVF	0	R/(W)*	<p>Overflow Flag</p> <p>Indicates that TCNT has overflowed. Only a write of 0 is permitted, to clear the flag.</p> <p>[Setting condition]</p> <ul style="list-style-type: none"> When TCNT overflows (changes from H'FF to H'00) <p>When internal reset request generation is selected in watchdog timer mode, OVF is cleared automatically by the internal reset.</p> <p>[Clearing condition]</p> <ul style="list-style-type: none"> Cleared by reading TCSR when OVF = 1, then writing 0 to OVF
6	WT/ $\overline{\text{IT}}$	0	R/W	<p>Timer Mode Select</p> <p>Selects whether the WDT is used as a watchdog timer or an interval timer.</p> <p>0: Interval timer mode 1: Watchdog timer mode</p>
5	TME	0	R/W	<p>Timer Enable</p> <p>When this bit is set to 1, TCNT starts counting. When this bit is cleared, TCNT stops counting and is initialized to H'00.</p>
4, 3	—	All 1	—	<p>Reserved</p> <p>These bits are always read as 1 and cannot be modified.</p>

Bit	Bit Name	Initial Value	R/W	Description
2	CKS2	0	R/W	Clock Select 2 to 0
1	CKS1	0	R/W	Selects the clock source to be input to TCNT. The overflow frequency for $\phi = 20$ MHz is enclosed in parentheses. 000: Clock $\phi/2$ (frequency: 25.6 μ s) 001: Clock $\phi/64$ (frequency: 819.2 μ s) 010: Clock $\phi/128$ (frequency: 1.6 ms) 011: Clock $\phi/512$ (frequency: 6.6 ms) 100: Clock $\phi/2048$ (frequency: 26.2 ms) 101: Clock $\phi/8192$ (frequency: 104.9 ms) 110: Clock $\phi/32768$ (frequency: 419.4 ms) 111: Clock $\phi/131072$ (frequency: 1.68 s)
0	CKS0	0	R/W	

Note: * Only 0 can be written, for flag clearing.

13.2.3 Reset Control/Status Register (RSTCSR)

RSTCSR is an 8-bit readable/writable register that controls the generation of the internal reset signal when TCNT overflows, and selects the type of internal reset signal. RSTCSR is initialized to H'1F by a reset signal from the $\overline{\text{RES}}$ pin, and not by the WDT internal reset signal caused by overflows.

Bit	Bit Name	Initial Value	R/W	Description
7	WOVF	0	R/(W)*	<p>Watchdog Overflow Flag</p> <p>This bit is set when TCNT overflows in watchdog timer mode. This bit cannot be set in interval timer mode, and only 0 can be written.</p> <p>[Setting condition]</p> <ul style="list-style-type: none"> Set when TCNT overflows (changed from H'FF to H'00) in watchdog timer mode <p>[Clearing condition]</p> <ul style="list-style-type: none"> Cleared by reading RSTCSR when WOVF = 1, and then writing 0 to WOVF
6	RSTE	0	R/W	<p>Reset Enable</p> <p>Specifies whether or not a reset signal is generated in the chip if TCNT overflows during watchdog timer operation.</p> <p>0: Reset signal is not generated even if TCNT overflows (Though this LSI is not reset, TCNT and TCSR in WDT are reset)</p> <p>1: Reset signal is generated if TCNT overflows</p>
5	RSTS	0	R/W	<p>Reset Select</p> <p>Selects the type of internal reset generated if TCNT overflows during watchdog timer operation.</p> <p>0: Power-on reset</p> <p>1: Setting prohibited</p>
4 to 0	—	All 1	—	<p>Reserved</p> <p>These bits are always read as 1 and cannot be modified.</p>

Note: * Only 0 can be written, for flag clearing.

13.3 Operation

13.3.1 Watchdog Timer Mode Operation

To use the WDT as a watchdog timer, set the $\overline{WT}/\overline{IT}$ bit in TCSR and the TME bit to 1. Software must prevent TCNT overflows by rewriting the TCNT value (normally by writing H'00) before overflow occurs. This ensures that TCNT does not overflow while the system is operating normally. If TCNT overflows without being rewritten because of a system malfunction or other error, the WOVF bit in RSTCSR is set to 1. If the RSTE bit in RSTCSR is set to 1, an internal reset is issued. This is shown in figure 13.2. At this time, select the power-on reset by clearing the RSTS bit in RSTCSR to 0. The internal reset signal is output for 518 states.

If a reset caused by a signal input to the \overline{RES} pin occurs at the same time as a reset caused by a WDT overflow, the reset by the \overline{RES} pin has priority and the WOVF bit in RSTCSR is cleared to 0.

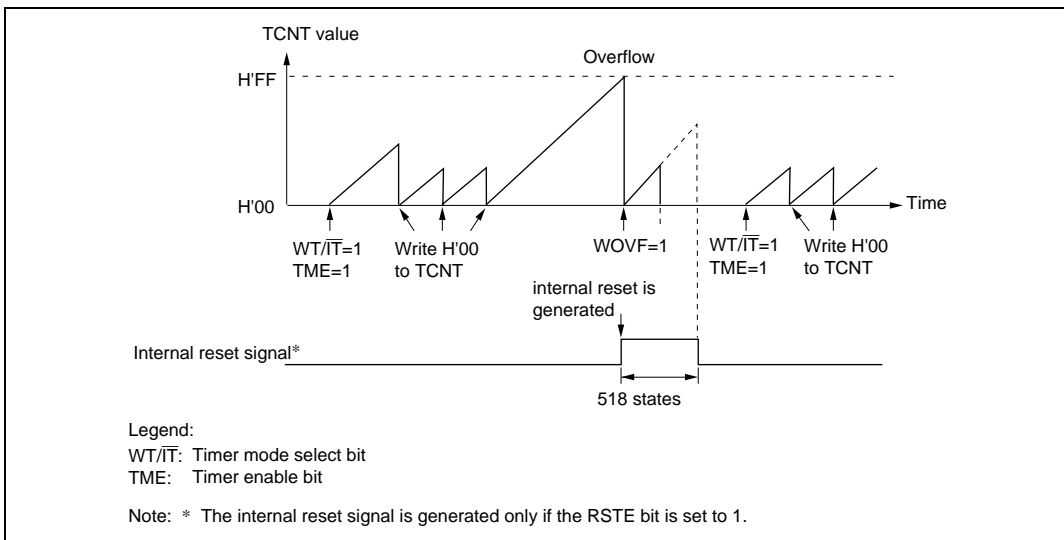

Figure 13.2 Example of WDT0 Watchdog Timer Operation

13.3.2 Interval Timer Mode

When the WDT is used as an interval timer, an interval timer interrupt (WOVI) is generated each time the TCNT overflows. Therefore, an interrupt can be generated at intervals.

When the TCNT overflows in interval timer mode, an interval timer interrupt (WOVI) is requested at the time the OVF bit of the TCSR is set to 1.

13.4 Interrupts

During interval timer mode operation, an overflow generates an interval timer interrupt (WOVI). The interval timer interrupt is requested whenever the OVF flag is set to 1 in TCSR. OVF must be cleared to 0 in the interrupt handling routine.

Table 13.1 WDT Interrupt Source

Name	Interrupt Source	Interrupt Flag	DTC Activation
WOVI	TCNT overflow	WOVF	Impossible

13.5 Usage Notes

13.5.1 Notes on Register Access

The watchdog timer's TCNT, TCSR, and RSTCSR registers differ from other registers in being more difficult to write to. The procedures for writing to and reading these registers are given below.

Writing to TCNT, TCSR, and RSTCSR: To write to TCNT and TCSR, execute a word transfer instruction. They cannot be written to by a byte transfer instruction.

TCNT and TCSR both have the same write address. Therefore, the relative condition shown in figure 13.3 needs to be satisfied in order to write to TCNT or TCSR. The transfer instruction writes the lower byte data to TCNT or TCSR according to the satisfied condition.

To write to RSTCSR, execute a word transfer instruction for address H'FF76. A byte transfer instruction cannot write to RSTCSR.

The method of writing 0 to the WOVF bit differs from that of writing to the RSTE and RSTS bits. To write 0 to the WOVF bit, satisfy the condition shown in figure 13.3. If satisfied, the transfer instruction clears the WOVF bit to 0, but has no effect on the RSTE and RSTS bits. To write to the RSTE and RSTS bits, satisfy the condition shown in figure 13.3. If satisfied, the transfer instruction writes the values in bits 6 and 5 of the lower byte into the RSTE and RSTS bits, respectively, but has no effect on the WOVF bit.

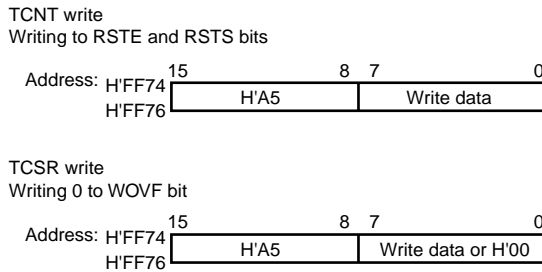

Figure 13.3 Writing to TCNT, TCSR, and RSTCSR (Example for WDT0)

Reading TCNT, TCSR, and RSTCSR (WDT0): These registers are read in the same way as other registers. The read addresses are H'FF74 for TCSR, H'FF75 for TCNT, and H'FF77 for RSTCSR.

13.5.2 Conflict between Timer Counter (TCNT) Write and Increment

If a timer counter clock pulse is generated during the T_2 state of a TCNT write cycle, the write takes priority and the timer counter is not incremented. Figure 13.4 shows this operation.

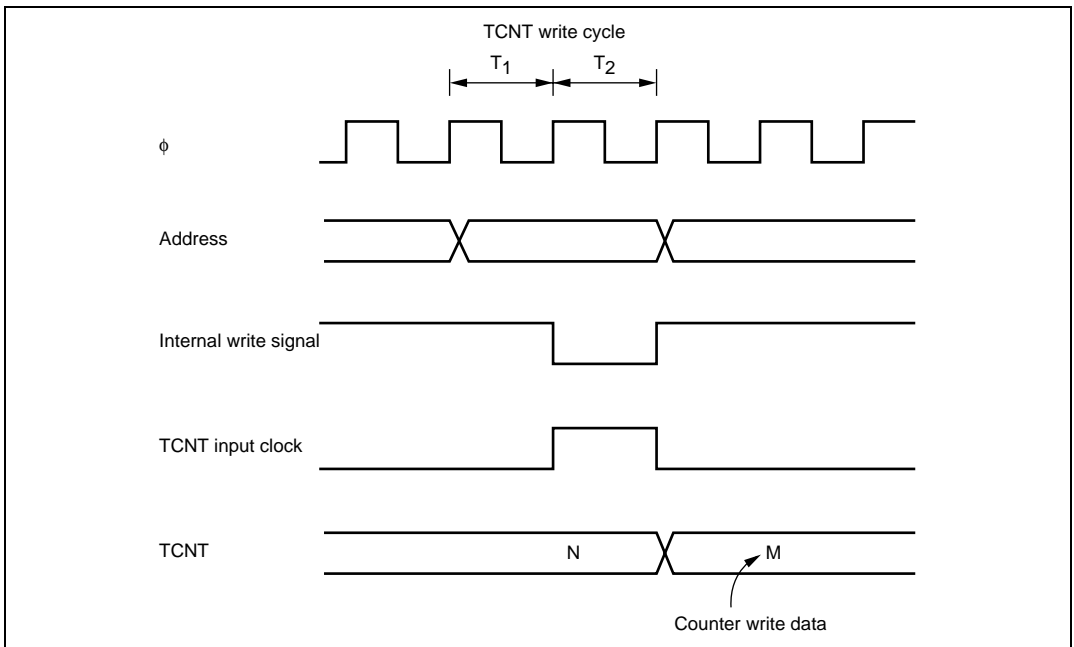

Figure 13.4 Conflict between TCNT Write and Increment

13.5.3 Changing Value of CKS2 to CKS0

If bits CKS2 to CKS0 in TCSR are written to while the WDT is operating, errors could occur in the incrementation. Software must be used to stop the watchdog timer (by clearing the TME bit to 0) before changing the value of bits CKS2 to CKS0.

13.5.4 Switching between Watchdog Timer Mode and Interval Timer Mode

If the mode is switched from watchdog timer to interval timer while the WDT is operating, errors could occur in the incrementation. Software must be used to stop the watchdog timer (by clearing the TME bit to 0) before switching the mode.

13.5.5 Internal Reset in Watchdog Timer Mode

This LSI is not reset internally if TCNT overflows while the RSTE bit is cleared to 0 during watchdog timer operation, however TCNT and TCSR of the WDT are reset.

TCNT, TCSR, or RSTCR cannot be written to for 132 states following an overflow. During this period, any attempt to read the WOVF flag is not acknowledged. Accordingly, wait 132 states after overflow to write 0 to the WOVF flag for clearing.

13.5.6 OVF Flag Clearing in Interval Timer Mode

When the OVF flag setting conflicts with the OVF flag reading in interval timer mode, writing 0 to the OVF bit may not clear the flag even though the OVF bit has been read while it is 1. If there is a possibility that the OVF flag setting and reading will conflict, such as when the OVF flag is polled with the interval timer interrupt disabled, read the OVF bit while it is 1 at least twice before writing 0 to the OVF bit to clear the flag.

Section 14 Serial Communication Interface (SCI)

This LSI has two independent serial communication interface (SCI) channels. The SCI can handle both asynchronous and clocked synchronous serial communication. Serial data communication can be carried out using standard asynchronous communication chips such as a Universal Asynchronous Receiver/Transmitter (UART) or an Asynchronous Communication Interface Adapter (ACIA). A function is also provided for serial communication between processors (multiprocessor communication function). The SCI also supports an IC card (Smart Card) interface conforming to ISO/IEC 7816-3 (Identification Card) as a serial communication interface extension function.

Figure 14.1 shows a block diagram of the SCI.

14.1 Features

- Choice of asynchronous or clocked synchronous serial communication mode
- Full-duplex communication capability
The transmitter and receiver are mutually independent, enabling transmission and reception to be executed simultaneously.
Double-buffering is used in both the transmitter and the receiver, enabling continuous transmission and continuous reception of serial data.
- On-chip baud rate generator allows any bit rate to be selected
External clock can be selected as a transfer clock source (except for in Smart Card interface mode).
- Choice of LSB-first or MSB-first transfer (except in the case of asynchronous mode 7-bit data)
- Four interrupt sources
Transmit-end, transmit-data-empty, receive-data-full, and receive error — that can issue requests.
The transmit-data-empty interrupt and receive-data-full interrupt can be used to activate the data transfer controller (DTC).
- Module stop mode can be set

Asynchronous mode

- Data length: 8 or 7 bits
- Stop bit length: 2 or 1 bits
- Parity: Even, odd, or none
- Receive error detection: Parity, overrun, and framing errors

- Break detection: Break can be detected by reading the RxD pin level directly in the case of a framing error

Clocked synchronous mode

- Data length: 8 bits
- Receive error detection: Overrun errors detected

Smart Card interface

- Automatic transmission of error signal (parity error) in receive mode
- Error signal detection and automatic data retransmission in transmit mode
- Direct convention and inverse convention both supported

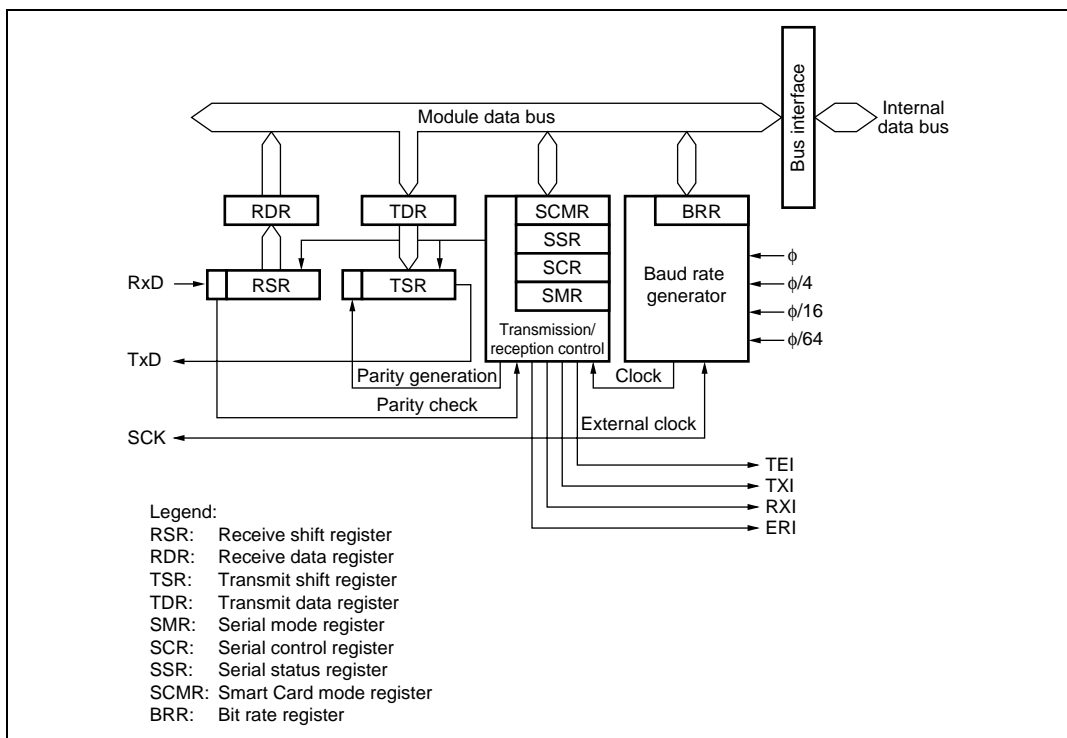

Figure 14.1 Block Diagram of SCI

14.2 Input/Output Pins

Table 14.1 shows the serial pins for each SCI channel.

Table 14.1 Pin Configuration

Channel	Pin Name*	I/O	Function
0	SCK0	I/O	SCI0 clock input/output
	RxD0	Input	SCI0 receive data input
	TxD0	Output	SCI0 transmit data output
2	SCK2	I/O	SCI2 clock input/output
	RxD2	Input	SCI2 receive data input
	TxD2	Output	SCI2 transmit data output

Note: * Pin names SCK, RxD, and TxD are used in the text for all channels, omitting the channel designation.

14.3 Register Descriptions

The SCI has the following registers for each channel. The serial mode register (SMR), serial status register (SSR), and serial control register (SCR) are described separately for normal serial communication interface mode and Smart Card interface mode because their bit functions differ in part.

- Receive Shift Register (RSR)
- Receive Data Register (RDR)
- Transmit Data Register (TDR)
- Transmit Shift Register (TSR)
- Serial Mode Register (SMR)
- Serial Control Register (SCR)
- Serial Status Register (SSR)
- Smart Card Mode Register (SCMR)
- Bit Rate Register (BRR)

14.3.1 Receive Shift Register (RSR)

RSR is a shift register that is used to receive serial data input to the RxD pin and convert it into parallel data. When one byte of data has been received, it is transferred to RDR automatically. RSR cannot be directly accessed by the CPU.

14.3.2 Receive Data Register (RDR)

RDR is an 8-bit register that stores received data. When the SCI has received one byte of serial data, it transfers the received serial data from RSR to RDR, where it is stored. After this, RSR is receive-enabled. As RSR and RDR function as a double buffer in this way, continuous receive operations are possible. After confirming that the RDRF bit in SSR is set to 1, read RDR only once. RDR cannot be written to by the CPU.

14.3.3 Transmit Data Register (TDR)

TDR is an 8-bit register that stores data for transmission. When the SCI detects that TSR is empty, it transfers the transmit data written in TDR to TSR and starts transmission. The double-buffered structure of TDR and TSR enables continuous serial transmission. If the next transmit data has already been written to TDR during serial transmission, the SCI transfers the written data to TSR to continue transmission. Although TDR can be read or written to by the CPU at all times, to achieve reliable serial transmission, write transmit data to TDR only once after confirming that the TDRE bit in SSR is set to 1.

14.3.4 Transmit Shift Register (TSR)

TSR is a shift register that transmits serial data. To perform serial data transmission, the SCI first transfers transmit data from TDR to TSR, then sends the data to the TxD pin. TSR cannot be directly accessed by the CPU.

14.3.5 Serial Mode Register (SMR)

SMR is used to set the SCI's serial transfer format and select the baud rate generator clock source.

Some bit functions of SMR differ between normal serial communication interface mode and Smart Card interface mode.

- Normal Serial Communication Interface Mode (When SMIF in SCMR Is 0)

Bit	Bit Name	Initial Value	R/W	Description
7	C/ \bar{A}	0	R/W	Communication Mode 0: Asynchronous mode 1: Clocked synchronous mode
6	CHR	0	R/W	Character Length (enabled only in asynchronous mode) 0: Selects 8 bits as the data length 1: Selects 7 bits as the data length. LSB-first is fixed and the MSB of TDR is not transmitted in transmission In clocked synchronous mode, a fixed data length of 8 bits is used.
5	PE	0	R/W	Parity Enable (enabled only in asynchronous mode) When this bit is set to 1, the parity bit is added to transmit data before transmission, and the parity bit is checked in reception. For a multiprocessor format, parity bit addition and checking are not performed regardless of the PE bit setting.
4	O/ \bar{E}	0	R/W	Parity Mode (enabled only when the PE bit is 1 in asynchronous mode) 0: Selects even parity 1: Selects odd parity

Bit	Bit Name	Initial Value	R/W	Description
3	STOP	0	R/W	<p>Stop Bit Length (enabled only in asynchronous mode)</p> <p>Selects the stop bit length in transmission.</p> <p>0: 1 stop bit 1: 2 stop bits</p> <p>In reception, only the first stop bit is checked. If the second stop bit is 0, it is treated as the start bit of the next transmit character.</p>
2	MP	0	R/W	<p>Multiprocessor Mode (enabled only in asynchronous mode)</p> <p>When this bit is set to 1, the multiprocessor communication function is enabled. The PE bit and O/\bar{E} bit settings are invalid in multiprocessor mode.</p>
1	CKS1	0	R/W	Clock Select 1 and 0
0	CKS0	0	R/W	<p>These bits select the clock source for the baud rate generator.</p> <p>00: ϕ clock (n = 0) 01: $\phi/4$ clock (n = 1) 10: $\phi/16$ clock (n = 2) 11: $\phi/64$ clock (n = 3)</p> <p>For the relationship between the bit rate register setting and the baud rate, see 14.3.9, Bit Rate Register (BRR). n is the decimal representation of the value of n in BRR (see 14.3.9, Bit Rate Register (BRR)).</p>

- Smart Card Interface Mode (When SMIF in SCMR Is 1)

Bit	Bit Name	Initial Value	R/W	Description
7	GM	0	R/W	<p>GSM Mode</p> <p>When this bit is set to 1, the SCI operates in GSM mode. In GSM mode, the timing of the TEND setting is advanced by 11.0 etu (Elementary Time Unit: the time for transfer of one bit), and clock output control mode addition is performed. For details, refer to section 14.7.8, Clock Output Control.</p>
6	BLK	0	R/W	<p>When this bit is set to 1, the SCI operates in block transfer mode. For details on block transfer mode, refer to section 14.7.3, Block Transfer Mode.</p>
5	PE	0	R/W	<p>Parity Enable (enabled only in asynchronous mode)</p> <p>When this bit is set to 1, the parity bit is added to transmit data in transmission, and the parity bit is checked in reception. In Smart Card interface mode, this bit must be set to 1.</p>
4	O/ \bar{E}	0	R/W	<p>Parity Mode (enabled only when the PE bit is 1 in asynchronous mode)</p> <p>0: Selects even parity 1: Selects odd parity</p> <p>For details on setting this bit in Smart Card interface mode, refer to section 14.7.2, Data Format (Except for Block Transfer Mode).</p>
3	BCP1	0	R/W	<p>Basic Clock Pulse 2 and 1</p>
2	BCP0	0	R/W	<p>These bits specify the number of basic clock periods in a 1-bit transfer interval on the Smart Card interface.</p> <p>00: 32 clock (S = 32) 01: 64 clock (S = 64) 10: 372 clock (S = 372) 11: 256 clock (S = 256)</p> <p>For details, refer to section 14.7.4, Receive Data Sampling Timing and Reception Margin in Smart Card Interface Mode. S stands for the value of S in BRR (see section 14.3.9, Bit Rate Register (BRR)).</p>

Bit	Bit Name	Initial Value	R/W	Description
1	CKS1	0	R/W	Clock Select 1 and 0
0	CKS0	0	R/W	These bits select the clock source for the baud rate generator. 00: ϕ clock (n = 0) 01: $\phi/4$ clock (n = 1) 10: $\phi/16$ clock (n = 2) 11: $\phi/64$ clock (n = 3) For the relationship between the bit rate register setting and the baud rate, see section 14.3.9, Bit Rate Register (BRR). n is the decimal representation of the value of n in BRR (see section 14.3.9, Bit Rate Register (BRR)).

14.3.6 Serial Control Register (SCR)

SCR is a register that enables or disables SCI transfer operations and interrupt requests, and is also used to selection of the transfer clock source. For details on interrupt requests, refer to section 14.8, Interrupt Sources. Some bit functions of SCR differ between normal serial communication interface mode and Smart Card interface mode.

- Normal Serial Communication Interface Mode (When SMIF in SCMR Is 0)

Bit	Bit Name	Initial Value	R/W	Description
7	TIE	0	R/W	Transmit Interrupt Enable When this bit is set to 1, the TXI interrupt request is enabled.
6	RIE	0	R/W	Receive Interrupt Enable When this bit is set to 1, RXI and ERI interrupt requests are enabled.
5	TE	0	R/W	Transmit Enable When this bit is set to 1, transmission is enabled.
4	RE	0	R/W	Receive Enable When this bit is set to 1, reception is enabled.
3	MPIE	0	R/W	Multiprocessor Interrupt Enable (enabled only when the MP bit in SMR is 1 in asynchronous mode) When this bit is set to 1, receive data in which the multiprocessor bit is 0 is skipped, and setting of the RDRF, FER, and ORER status flags in SSR is prohibited. On receiving data in which the multiprocessor bit is 1, this bit is automatically cleared and normal reception is resumed. For details, refer to 14.5, Multiprocessor Communication Function.
2	TEIE	0	R/W	Transmit End Interrupt Enable This bit is set to 1, TEI interrupt request is enabled.

Bit	Bit Name	Initial Value	R/W	Description
1	CKE1	0	R/W	Clock Enable 0 and 1
0	CKE0	0	R/W	Selects the clock source and SCK pin function. Asynchronous mode 00: Internal baud rate generator SCK pin functions as I/O port 01: Internal baud rate generator Outputs a clock of the same frequency as the bit rate from the SCK pin. 1×: External clock Inputs a clock with a frequency 16 times the bit rate from the SCK pin. Clock synchronous mode 0×: Internal clock (SCK pin functions as clock output) 1×: External clock (SCK pin functions as clock input)

Legend:

×: Don't care

- Smart Card Interface Mode (When SMIF in SCMR Is 1)

Bit	Bit Name	Initial Value	R/W	Description
7	TIE	0	R/W	Transmit Interrupt Enable When this bit is set to 1, TXI interrupt request is enabled.
6	RIE	0	R/W	Receive Interrupt Enable When this bit is set to 1, RXI and ERI interrupt requests are enabled.
5	TE	0	R/W	Transmit Enable When this bit is set to 1, transmission is enabled.
4	RE	0	R/W	Receive Enable When this bit is set to 1, reception is enabled.
3	MPIE	0	R/W	Multiprocessor Interrupt Enable (enabled only when the MP bit in SMR is 1 in asynchronous mode) Write 0 to this bit in Smart Card interface mode.
2	TEIE	0	R/W	Transmit End Interrupt Enable Write 0 to this bit in Smart Card interface mode.
1	CKE1	0	R/W	Clock Enable 1 and 0
0	CKE0	0	R/W	Enables or disables clock output from the SCK pin. The clock output can be dynamically switched in GSM mode. For details, refer to section 14.7.8, Clock Output Control. When the GM bit in SMR is 0 00: Output disabled (SCK pin can be used as an I/O port pin) 01: Clock output 1x: Reserved When the GM bit in SMR is 1 00: Output fixed low 01: Clock output 10: Output fixed high 11: Clock output

Legend:

x: Don't care

14.3.7 Serial Status Register (SSR)

SSR is a register containing status flags of the SCI and multiprocessor bits for transfer. 1 cannot be written to flags TDRE, RDRF, ORER, PER, and FER; they can only be cleared. Some bit functions of SSR differ between normal serial communication interface mode and Smart Card interface mode.

- Normal Serial Communication Interface Mode (When SMIF in SCMR Is 0)

Bit	Bit Name	Initial Value	R/W	Description
7	TDRE	1	R/W	<p>Transmit Data Register Empty</p> <p>Displays whether TDR contains transmit data.</p> <p>[Setting conditions]</p> <ul style="list-style-type: none"> • When the TE bit in SCR is 0 • When data is transferred from TDR to TSR and data can be written to TDR <p>[Clearing conditions]</p> <ul style="list-style-type: none"> • When 0 is written to TDRE after reading TDRE = 1 • When the DTC is activated by a TXI interrupt request and writes data to TDR
6	RDRF	0	R/W	<p>Receive Data Register Full</p> <p>Indicates that the received data is stored in RDR.</p> <p>[Setting condition]</p> <ul style="list-style-type: none"> • When serial reception ends normally and receive data is transferred from RSR to RDR <p>[Clearing conditions]</p> <ul style="list-style-type: none"> • When 0 is written to RDRF after reading RDRF = 1 • When the DTC is activated by an RXI interrupt and transferred data from RDR <p>The RDRF flag is not affected and retains their previous values when the RE bit in SCR is cleared to 0.</p>

Bit	Bit Name	Initial Value	R/W	Description
5	ORER	0	R/W	<p>Overrun Error</p> <p>[Setting condition]</p> <ul style="list-style-type: none"> When the next serial reception is completed while RDRF = 1 <p>[Clearing condition]</p> <ul style="list-style-type: none"> When 0 is written to ORER after reading ORER = 1
4	FER	0	R/W	<p>Framing Error</p> <p>[Setting condition]</p> <ul style="list-style-type: none"> When the stop bit is 0 <p>[Clearing condition]</p> <ul style="list-style-type: none"> When 0 is written to FER after reading FER = 1 <p>In 2-stop-bit mode, only the first stop bit is checked.</p>
3	PER	0	R/W	<p>Parity Error</p> <p>[Setting condition]</p> <ul style="list-style-type: none"> When a parity error is detected during reception <p>[Clearing condition]</p> <ul style="list-style-type: none"> When 0 is written to PER after reading PER = 1

Bit	Bit Name	Initial Value	R/W	Description
2	TEND	1	R	<p>Transmit End</p> <p>[Setting conditions]</p> <ul style="list-style-type: none">• When the TE bit in SCR is 0• When TDRE = 1 at transmission of the last bit of a 1-byte serial transmit character <p>[Clearing conditions]</p> <ul style="list-style-type: none">• When 0 is written to TDRE after reading TDRE = 1• When the DTC is activated by a TXI interrupt and writes data to TDR
1	MPB	0	R	<p>Multiprocessor Bit</p> <p>MPB stores the multiprocessor bit in the receive data. When the RE bit in SCR is cleared to 0 its previous state is retained.</p>
0	MPBT	0	R/W	<p>Multiprocessor Bit Transfer</p> <p>MPBT stores the multiprocessor bit to be added to the transmit data.</p>

- Smart Card Interface Mode (When SMIF in SCMR Is 1)

Bit	Bit Name	Initial Value	R/W	Description
7	TDRE	1	R/W	<p>Transmit Data Register Empty</p> <p>Displays whether TDR contains transmit data.</p> <p>[Setting conditions]</p> <ul style="list-style-type: none"> • When the TE bit in SCR is 0 • When data is transferred from TDR to TSR and data can be written to TDR <p>[Clearing conditions]</p> <ul style="list-style-type: none"> • When 0 is written to TDRE after reading TDRE = 1 • When the DTC is activated by a TXI interrupt request and writes data to TDR
6	RDRF	0	R/W	<p>Receive Data Register Full</p> <p>Indicates that the received data is stored in RDR.</p> <p>[Setting condition]</p> <ul style="list-style-type: none"> • When serial reception ends normally and receive data is transferred from RSR to RDR <p>[Clearing conditions]</p> <ul style="list-style-type: none"> • When 0 is written to RDRF after reading RDRF = 1 • When the DTC is activated by an RXI interrupt and transferred data from RDR <p>The RDRF flag is not affected and retains their previous values when the RE bit in SCR is cleared to 0.</p>

Bit	Bit Name	Initial Value	R/W	Description
5	ORER	0	R/W	<p>Overrun Error</p> <p>[Setting condition]</p> <ul style="list-style-type: none">When the next serial reception is completed while RDRF = 1 <p>[Clearing condition]</p> <ul style="list-style-type: none">When 0 is written to ORER after reading ORER = 1
4	ERS	0	R/W	<p>Error Signal Status</p> <p>[Setting condition]</p> <ul style="list-style-type: none">When the low level of the error signal is sampled <p>[Clearing condition]</p> <ul style="list-style-type: none">When 0 is written to ERS after reading ERS = 1
3	PER	0	R/W	<p>Parity Error</p> <p>[Setting condition]</p> <ul style="list-style-type: none">When a parity error is detected during reception <p>[Clearing condition]</p> <ul style="list-style-type: none">When 0 is written to PER after reading PER = 1

Bit	Bit Name	Initial Value	R/W	Description
2	TEND	1	R	<p>Transmit End</p> <p>This bit is set to 1 when no error signal has been sent back from the receiving end and the next transmit data is ready to be transferred to TDR.</p> <p>[Setting conditions]</p> <ul style="list-style-type: none"> • When the TE bit in SCR is 0 and the ERS bit is also 0 • When the ERS bit is 0 and the TDRE bit is 1 after the specified interval following transmission of 1-byte data. <p>The timing of bit setting differs according to the register setting as follows:</p> <p>When GM = 0 and BLK = 0, 2.5 etu after transmission starts</p> <p>When GM = 0 and BLK = 1, 1.5 etu after transmission starts</p> <p>When GM = 1 and BLK = 0, 1.0 etu after transmission starts</p> <p>When GM = 1 and BLK = 1, 1.0 etu after transmission starts</p> <p>[Clearing conditions]</p> <ul style="list-style-type: none"> • When 0 is written to TDRE after reading TDRE = 1 • When the DTC is activated by a TXI interrupt and writes data to TDR
1	MPB	0	R	<p>Multiprocessor Bit</p> <p>This bit is not used in Smart Card interface mode.</p>
0	MPBT	0	R/W	<p>Multiprocessor Bit Transfer</p> <p>Write 0 to this bit in Smart Card interface mode.</p>

14.3.8 Smart Card Mode Register (SCMR)

SCMR is a register that selects Smart Card interface mode and its format.

Bit	Bit Name	Initial Value	R/W	Description
7 to 4	—	All 1	—	Reserved These bits are always read as 1.
3	SDIR	0	R/W	Smart Card Data Transfer Direction Selects the serial/parallel conversion format. 0: LSB-first in transfer 1: MSB-first in transfer The bit setting is valid only when the transfer data format is 8 bits. For 7-bit data, LSB-first is fixed.
2	SINV	0	R/W	Smart Card Data Invert Specifies inversion of the data logic level. The SINV bit does not affect the logic level of the parity bit. To invert the parity bit, invert the O/\bar{E} bit in SMR. 0: TDR contents are transmitted as they are. Receive data is stored as it is in RDR 1: TDR contents are inverted before being transmitted. Receive data is stored in inverted form in RDR
1	—	1	—	Reserved This bit is always read as 1.
0	SMIF	0	R/W	Smart Card Interface Mode Select This bit is set to 1 to make the SCI operate in Smart Card interface mode. 0: Normal asynchronous mode or clocked synchronous mode 1: Smart card interface mode

14.3.9 Bit Rate Register (BRR)

BRR is an 8-bit register that adjusts the bit rate. As the SCI performs baud rate generator control independently for each channel, different bit rates can be set for each channel. Table 14.2 shows the relationships between the N setting in BRR and bit rate B for normal asynchronous mode, clocked synchronous mode, and Smart Card interface mode. The initial value of BRR is H'FF, and it can be read or written to by the CPU at all times.

Table 14.2 The Relationships between The N Setting in BRR and Bit Rate B

Mode	BRR Setting N	Error
Asynchronous Mode	$N = \frac{\phi \times 10^6}{64 \times 2^{2n-1} \times B} - 1$	$\text{Error (\%)} = \left\{ \frac{\phi \times 10^6}{B \times 64 \times 2^{2n-1} \times (N + 1)} - 1 \right\} \times 100$
Clocked Synchronous Mode	$N = \frac{\phi \times 10^6}{8 \times 2^{2n-1} \times B} - 1$	
Smart Card Interface Mode	$N = \frac{\phi \times 10^6}{S \times 2^{2n+1} \times B} - 1$	$\text{Error (\%)} = \left\{ \frac{\phi \times 10^6}{B \times S \times 2^{2n+1} \times (N + 1)} - 1 \right\} \times 100$

Legend: B: Bit rate (bit/s)
 N: BRR setting for baud rate generator ($0 \leq N \leq 255$)
 ϕ : Operating frequency (MHz)
 n and S: Determined by the SMR settings shown in the following tables.

SMR Setting			SMR Setting		
CKS1	CKS0	n	BCP1	BCP0	S
0	0	0	0	0	32
0	1	1	0	1	64
1	0	2	1	0	372
1	1	3	1	1	256

Table 14.3 shows sample N settings in BRR in normal asynchronous mode. Table 14.4 shows the maximum bit rate for each frequency in normal asynchronous mode. Table 14.6 shows sample N settings in BRR in clocked synchronous mode. Table 14.8 shows sample N settings in BRR in Smart Card interface mode. In Smart Card interface mode, S (the number of basic clock periods in a 1-bit transfer interval) can be selected. For details, refer to section 14.7.4, Receive Data Sampling Timing and Reception Margin in Smart Card Interface Mode. Tables 14.5 and 14.7 show the maximum bit rates with external clock input.

Table 14.3 BRR Settings for Various Bit Rates (Asynchronous Mode) (1)

Bit Rate (bit/s)	Operating Frequency ϕ (MHz)								
	4			4.9152			5		
	n	N	Error (%)	n	N	Error (%)	n	N	Error (%)
110	2	70	0.03	2	86	0.31	2	88	-0.25
150	1	207	0.16	1	255	0.00	2	64	0.16
300	1	103	0.16	1	127	0.00	1	129	0.16
600	0	207	0.16	0	255	0.00	1	64	0.16
1200	0	103	0.16	0	127	0.00	0	129	0.16
2400	0	51	0.16	0	63	0.00	0	64	0.16
4800	0	25	0.16	0	31	0.00	0	32	-1.36
9600	0	12	0.16	0	15	0.00	0	15	1.73
19200	—	—	—	0	7	0.00	0	7	1.73
31250	0	3	0.00	0	4	-1.70	0	4	0.00
38400	—	—	—	0	3	0.00	0	3	1.73

Bit Rate (bit/s)	Operating Frequency ϕ (MHz)											
	6			6.144			7.3728			8		
	n	N	Error (%)	n	N	Error (%)	n	N	Error (%)	n	N	Error (%)
110	2	106	-0.44	2	108	0.08	2	130	-0.07	2	141	0.03
150	2	77	0.16	2	79	0.00	2	95	0.00	2	103	0.16
300	1	155	0.16	1	159	0.00	1	191	0.00	1	207	0.16
600	1	77	0.16	1	79	0.00	1	95	0.00	1	103	0.16
1200	0	155	0.16	0	159	0.00	0	191	0.00	0	207	0.16
2400	0	77	0.16	0	79	0.00	0	95	0.00	0	103	0.16
4800	0	38	0.16	0	39	0.00	0	47	0.00	0	51	0.16
9600	0	19	-2.34	0	19	0.00	0	23	0.00	0	25	0.16
19200	0	9	-2.34	0	9	0.00	0	11	0.00	0	12	0.16
31250	0	5	0.00	0	5	2.40	—	—	—	0	7	0.00
38400	0	4	-2.34	0	4	0.00	0	5	0.00	—	—	—

Table 14.3 BRR Settings for Various Bit Rates (Asynchronous Mode) (2)

Bit Rate (bit/s)	Operating Frequency ϕ (MHz)											
	9.8304			10			12			12.288		
	n	N	Error (%)	n	N	Error (%)	n	N	Error (%)	n	N	Error (%)
110	2	174	-0.26	2	177	-0.25	2	212	0.03	2	217	0.08
150	2	127	0.00	2	129	0.16	2	155	0.16	2	159	0.00
300	1	255	0.00	2	64	0.16	2	77	0.16	2	79	0.00
600	1	127	0.00	1	129	0.16	1	155	0.16	1	159	0.00
1200	0	255	0.00	1	64	0.16	1	77	0.16	1	79	0.00
2400	0	127	0.00	0	129	0.16	0	155	0.16	0	159	0.00
4800	0	63	0.00	0	64	0.16	0	77	0.16	0	79	0.00
9600	0	31	0.00	0	32	-1.36	0	38	0.16	0	39	0.00
19200	0	15	0.00	0	15	1.73	0	19	-2.34	0	19	0.00
31250	0	9	-1.70	0	9	0.00	0	11	0.00	0	11	2.40
38400	0	7	0.00	0	7	1.73	0	9	-2.34	0	9	0.00

Bit Rate (bit/s)	Operating Frequency ϕ (MHz)											
	14			14.7456			16			17.2032		
	n	N	Error (%)	n	N	Error (%)	n	N	Error (%)	n	N	Error (%)
110	2	248	-0.17	3	64	0.70	3	70	0.03	3	75	0.48
150	2	181	0.13	2	191	0.00	2	207	0.13	2	223	0.00
300	2	90	0.13	2	95	0.00	2	103	0.13	2	111	0.00
600	1	181	0.13	1	191	0.00	1	207	0.13	1	223	0.00
1200	1	90	0.13	1	95	0.00	1	103	0.13	1	111	0.00
2400	0	181	0.13	0	191	0.00	0	207	0.13	0	223	0.00
4800	0	90	0.13	0	95	0.00	0	103	0.13	0	111	0.00
9600	0	45	-0.93	0	47	0.00	0	51	0.13	0	55	0.00
19200	0	22	-0.93	0	23	0.00	0	25	0.13	0	27	0.00
31250	0	13	0.00	0	14	-1.70	0	15	0.00	0	13	1.20
38400	—	—	—	0	11	0.00	0	12	0.13	0	13	0.00

Table 14.3 BRR Settings for Various Bit Rates (Asynchronous Mode) (3)

Bit Rate (bit/s)	Operating Frequency ϕ (MHz)											
	18			19.6608			20			24		
	n	N	Error (%)	n	N	Error (%)	n	N	Error (%)	n	N	Error (%)
110	3	79	-0.12	3	86	0.31	3	88	-0.25	3	106	-0.44
150	2	233	0.16	2	255	0.00	3	64	0.16	3	77	0.16
300	2	116	0.16	2	127	0.00	2	129	0.16	2	155	0.16
600	1	233	0.16	1	255	0.00	2	64	0.16	2	77	0.16
1200	1	116	0.16	1	127	0.00	1	129	0.16	1	155	0.16
2400	0	233	0.16	0	255	0.00	1	64	0.16	1	77	0.16
4800	0	116	0.16	0	127	0.00	0	129	0.16	0	155	0.16
9600	0	58	-0.69	0	63	0.00	0	64	0.16	0	77	0.16
19200	0	28	1.02	0	31	0.00	0	32	-1.36	0	38	0.16
31250	0	17	0.00	0	19	-1.70	0	19	0.00	0	23	0
38400	0	14	-2.34	0	15	0.00	0	15	1.73	0	19	-2.34

Table 14.4 Maximum Bit Rate for Each Frequency (Asynchronous Mode)

ϕ (MHz)	Maximum Bit Rate (bit/s)	n	N	ϕ (MHz)	Maximum Bit Rate (bit/s)	n	N
4	125000	0	0	12	375000	0	0
4.9152	153600	0	0	12.288	384000	0	0
5	156250	0	0	14	437500	0	0
6	187500	0	0	14.7456	460800	0	0
6.144	192000	0	0	16	500000	0	0
7.3728	230400	0	0	17.2032	537600	0	0
8	250000	0	0	18	562500	0	0
9.8304	307200	0	0	19.6608	614400	0	0
10	312500	0	0	20	625000	0	0
				24	750000	0	0

Table 14.5 Maximum Bit Rate with External Clock Input (Asynchronous Mode)

ϕ (MHz)	External Input Clock (MHz)	Maximum Bit Rate (bit/s)	ϕ (MHz)	External Input Clock (MHz)	Maximum Bit Rate (bit/s)
4	1.0000	62500	12	3.0000	187500
4.9152	1.2288	76800	12.288	3.0720	192000
5	1.2500	78125	14	3.5000	218750
6	1.5000	93750	14.7456	3.6864	230400
6.144	1.5360	96000	16	4.0000	250000
7.3728	1.8432	115200	17.2032	4.3008	268800
8	2.0000	125000	18	4.5000	281250
9.8304	2.4576	153600	19.6608	4.9152	307200
10	2.5000	156250	20	5.0000	312500
			24	6.0000	375000

Table 14.6 BRR Settings for Various Bit Rates (Clocked Synchronous Mode)

Bit Rate (bit/s)	Operating Frequency ϕ (MHz)											
	4		8		10		16		20		24	
	n	N	n	N	n	N	n	N	n	N	n	N
110	—	—										
250	2	249	3	124	—	—	3	249				
500	2	124	2	249	—	—	3	124	—	—	—	—
1 k	1	249	2	124	—	—	2	249	—	—	—	—
2.5 k	1	99	1	199	1	249	2	99	2	124	2	149
5 k	0	199	1	99	1	124	1	199	1	249	2	74
10 k	0	99	0	199	0	249	1	99	1	124	1	149
25 k	0	39	0	79	0	99	0	159	0	199	1	59
50 k	0	19	0	39	0	49	0	79	0	99	1	29
100 k	0	9	0	19	0	24	0	39	0	49	0	59
250 k	0	3	0	7	0	9	0	15	0	19	0	23
500 k	0	1	0	3	0	4	0	7	0	9	0	11
1 M	0	0*	0	1			0	3	0	4	0	5
2.5 M					0	0*			0	1	—	—
5 M									0	0*	—	—

Legend:

Blank: Setting prohibited.

—: Can be set, but there will be a degree of error.

*: Continuous transfer is not possible.

Table 14.7 Maximum Bit Rate with External Clock Input (Clocked Synchronous Mode)

ϕ (MHz)	External Input Clock (MHz)	Maximum Bit Rate (bit/s)	ϕ (MHz)	External Input Clock (MHz)	Maximum Bit Rate (bit/s)
4	0.6667	666666.7	14	2.3333	2333333.3
6	1.0000	1.000000.0	16	2.6667	2666666.7
8	1.3333	1333333.3	18	3.0000	3000000.0
10	1.6667	1666666.7	20	3.3333	3333333.3
12	2.0000	2000000.0	24	4	4000000.0

Table 14.8 Examples of Bit Rate for Various BRR Settings (Smart Card Interface Mode)
(When $n = 0$ and $S = 372$)

Bit Rate (bit/s)	Operating Frequency ϕ (MHz)											
	7.1424			10.00			10.7136			13.00		
	n	N	Error (%)	n	N	Error (%)	n	N	Error (%)	n	N	Error (%)
9600	0	0	0.00	0	1	30	0	1	25	0	1	8.99

Bit Rate (bit/s)	Operating Frequency ϕ (MHz)														
	14.2848			16.00			18.00			20.00			24.00		
	n	N	Error (%)	n	N	Error (%)	n	N	Error (%)	n	N	Error (%)	n	N	Error (%)
9600	0	1	0.00	0	1	12.01	0	2	15.99	0	2	6.60	0	2	12.01

Table 14.9 Maximum Bit Rate at Various Frequencies (Smart Card Interface Mode)
(When $S = 372$)

ϕ (MHz)	Maximum Bit Rate (bit/s)	n	N	ϕ (MHz)	Maximum Bit Rate (bit/s)	n	N
7.1424	9600	0	0	14.2848	19200	0	0
10.00	13441	0	0	16.00	21505	0	0
10.7136	14400	0	0	18.00	24194	0	0
13.00	17473	0	0	20.00	26882	0	0
				24.00	32258	0	0

14.4 Operation in Asynchronous Mode

Figure 14.2 shows the general format for asynchronous serial communication. One frame consists of a start bit (low level), followed by transfer/receive data (in LSB-first order), a parity bit (high or low level), and finally stop bits (high level). In asynchronous serial communication, the transmission line is usually held in the mark state (high level). The SCI monitors the transmission line. When the transmission line goes to the space state (low level), the SCI recognizes a start bit and starts serial communication. Inside the SCI, the transmitter and receiver are independent units, enabling full-duplex. Both the transmitter and the receiver also have a double-buffered structure, so data can be read or written during transmission or reception, enabling continuous data transfer.

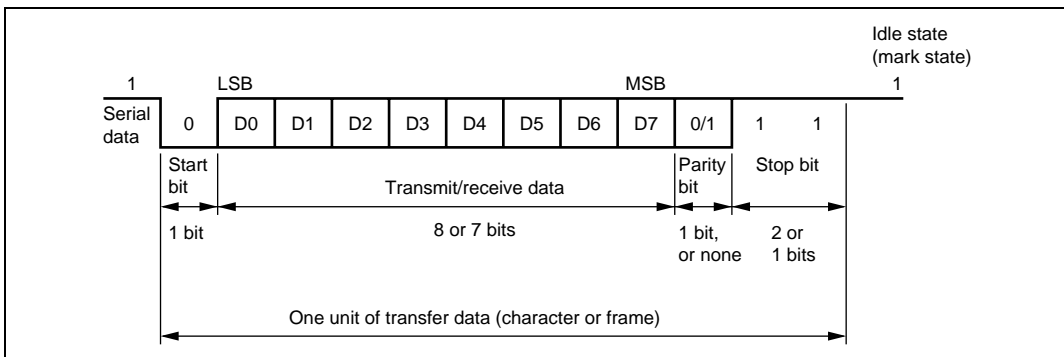

**Figure 14.2 Data Format in Asynchronous Communication
(Example with 8-Bit Data, Parity, Two Stop Bits)**

14.4.1 Data Transfer Format

Table 14.10 shows the data transfer formats that can be used in asynchronous mode. Any of 12 transfer formats can be selected according to the SMR setting. For details on the multiprocessor bit, refer to section 14.5, Multiprocessor Communication Function.

Table 14.10 Serial Transfer Formats (Asynchronous Mode)

SMR Settings				Serial Transfer Format and Frame Length													
CHR	PE	MP	STOP	1	2	3	4	5	6	7	8	9	10	11	12		
0	0	0	0	S	8-bit data								STOP				
0	0	0	1	S	8-bit data								STOP	STOP			
0	1	0	0	S	8-bit data								P	STOP			
0	1	0	1	S	8-bit data								P	STOP	STOP		
1	0	0	0	S	7-bit data							STOP					
1	0	0	1	S	7-bit data							STOP	STOP				
1	1	0	0	S	7-bit data							P	STOP				
1	1	0	1	S	7-bit data							P	STOP	STOP			
0	—	1	0	S	8-bit data								MPB	STOP			
0	—	1	1	S	8-bit data								MPB	STOP	STOP		
1	—	1	0	S	7-bit data							MPB	STOP				
1	—	1	1	S	7-bit data							MPB	STOP	STOP			

Legend:

S: Start bit

STOP: Stop bit

P: Parity bit

MPB: Multiprocessor bit

14.4.2 Receive Data Sampling Timing and Reception Margin in Asynchronous Mode

In asynchronous mode, the SCI operates on a basic clock with a frequency of 16 times the transfer rate. In reception, the SCI samples the falling edge of the start bit using the basic clock, and performs internal synchronization. Receive data is latched internally at the rising edge of the 8th pulse of the basic clock as shown in figure 14.3. Thus, the reception margin in asynchronous mode is given by formula (1) below.

$$M = \left\{ \left(0.5 - \frac{1}{2N} \right) - \frac{D - 0.5}{N} - (L - 0.5) F \right\} \times 100 [\%]$$

... Formula (1)

Where N: Ratio of bit rate to clock ($N = 16$)
 D: Clock duty cycle ($D = 0.5$ to 1.0)
 L: Frame length ($L = 9$ to 12)
 F: Absolute value of clock rate deviation

Assuming values of F (absolute value of clock rate deviation) = 0 and D (clock duty cycle) = 0.5 in formula (1), the reception margin can be given by the formula.

$$M = \{ 0.5 - 1/(2 \times 16) \} \times 100 [\%] = 46.875\%$$

However, this is only the computed value, and a margin of 30% to 20% should be allowed for in system design.

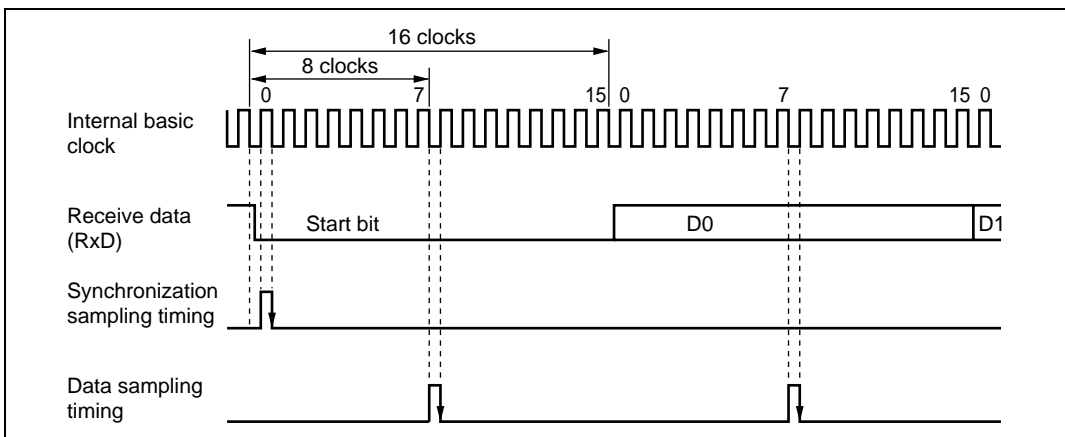

Figure 14.3 Receive Data Sampling Timing in Asynchronous Mode

14.4.3 Clock

Either an internal clock generated by the on-chip baud rate generator or an external clock input at the SCK pin can be selected as the SCI's serial clock, according to the setting of the C/\bar{A} bit in SMR and the CKE0 and CKE1 bits in SCR. When an external clock is input at the SCK pin, the clock frequency should be 16 times the bit rate used.

When the SCI is operated on an internal clock, the clock can be output from the SCK pin. The frequency of the clock output in this case is equal to the bit rate, and the phase is such that the rising edge of the clock is in the middle of the transmit data, as shown in figure 14.4.

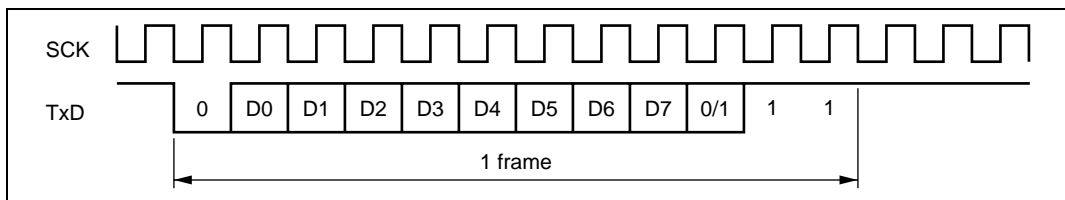

Figure 14.4 Relationship between Output Clock and Transfer Data Phase (Asynchronous Mode)

14.4.4 SCI Initialization (Asynchronous Mode)

Before transmitting and receiving data, first clear the TE and RE bits in SCR to 0, then initialize the SCI as described below. When the operating mode, or transfer format, is changed for example, the TE and RE bits must be cleared to 0 before making the change using the following procedure. When the TE bit is cleared to 0, the TDRE flag is set to 1. Note that clearing the RE bit to 0 does not initialize the contents of the RDRF, PER, FER, and ORER flags, or the contents of RDR. When the external clock is used in asynchronous mode, the clock must be supplied even during initialization.

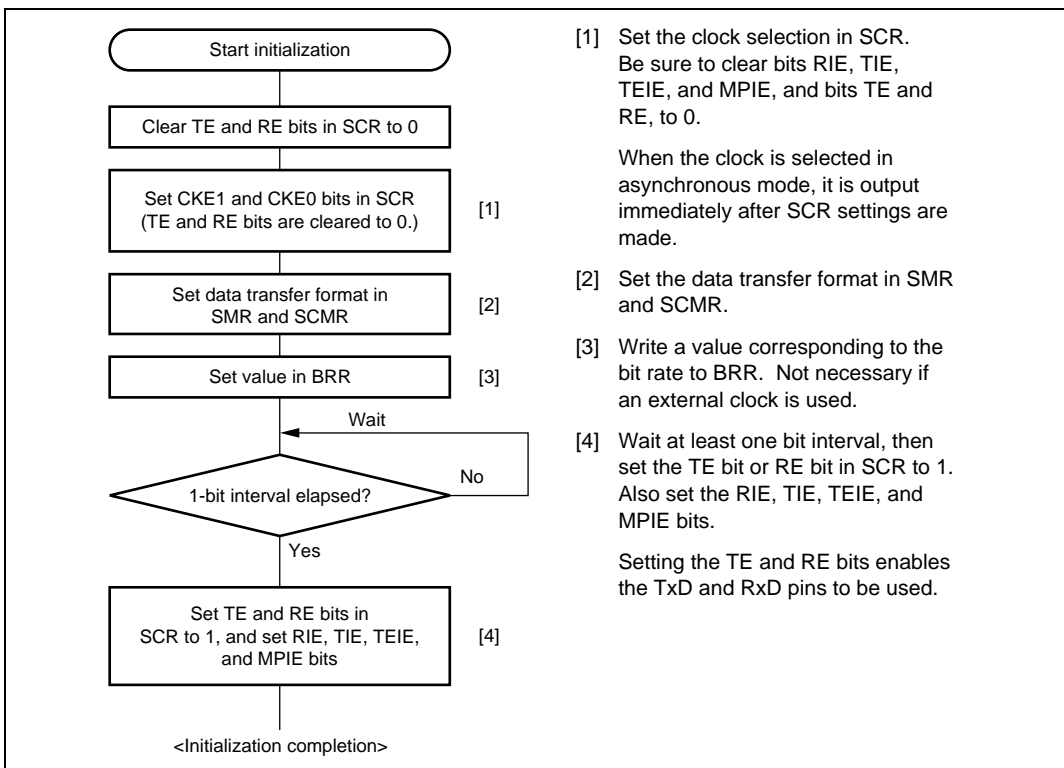

Figure 14.5 Sample SCI Initialization Flowchart

14.4.5 Data Transmission (Asynchronous Mode)

Figure 14.6 shows an example of operation for transmission in asynchronous mode. In transmission, the SCI operates as described below.

1. The SCI monitors the TDRE flag in SSR. If the flag is cleared to 0, the SCI recognizes that data has been written to TDR, and transfers the data from TDR to TSR.
2. After transferring data from TDR to TSR, the SCI sets the TDRE flag to 1 and starts transmission. If the TIE bit is set to 1 at this time, a transmit data empty interrupt request (TXI) is generated. Continuous transmission is possible because the TXI interrupt routine writes next transmit data to TDR before transmission of the current transmit data has been completed.
3. Data is sent from the TxD pin in the following order: start bit, transmit data, parity bit or multiprocessor bit (may be omitted depending on the format), and stop bit.
4. The SCI checks the TDRE flag at the timing for sending the stop bit.
5. If the TDRE flag is 0, the data is transferred from TDR to TSR, the stop bit is sent, and then serial transmission of the next frame is started.
6. If the TDRE flag is 1, the TEND flag in SSR is set to 1, the stop bit is sent, and then the “mark state” is entered, in which 1 is output. If the TEIE bit in SCR is set to 1 at this time, a TEI interrupt request is generated.

Figure 14.7 shows a sample flowchart for transmission in asynchronous mode.

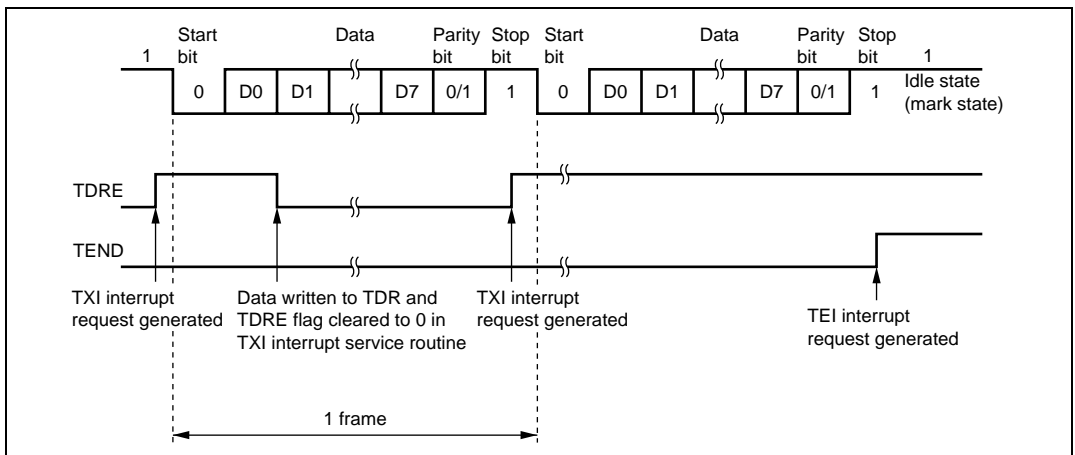

**Figure 14.6 Example of Operation in Transmission in Asynchronous Mode
(Example with 8-Bit Data, Parity, One Stop Bit)**

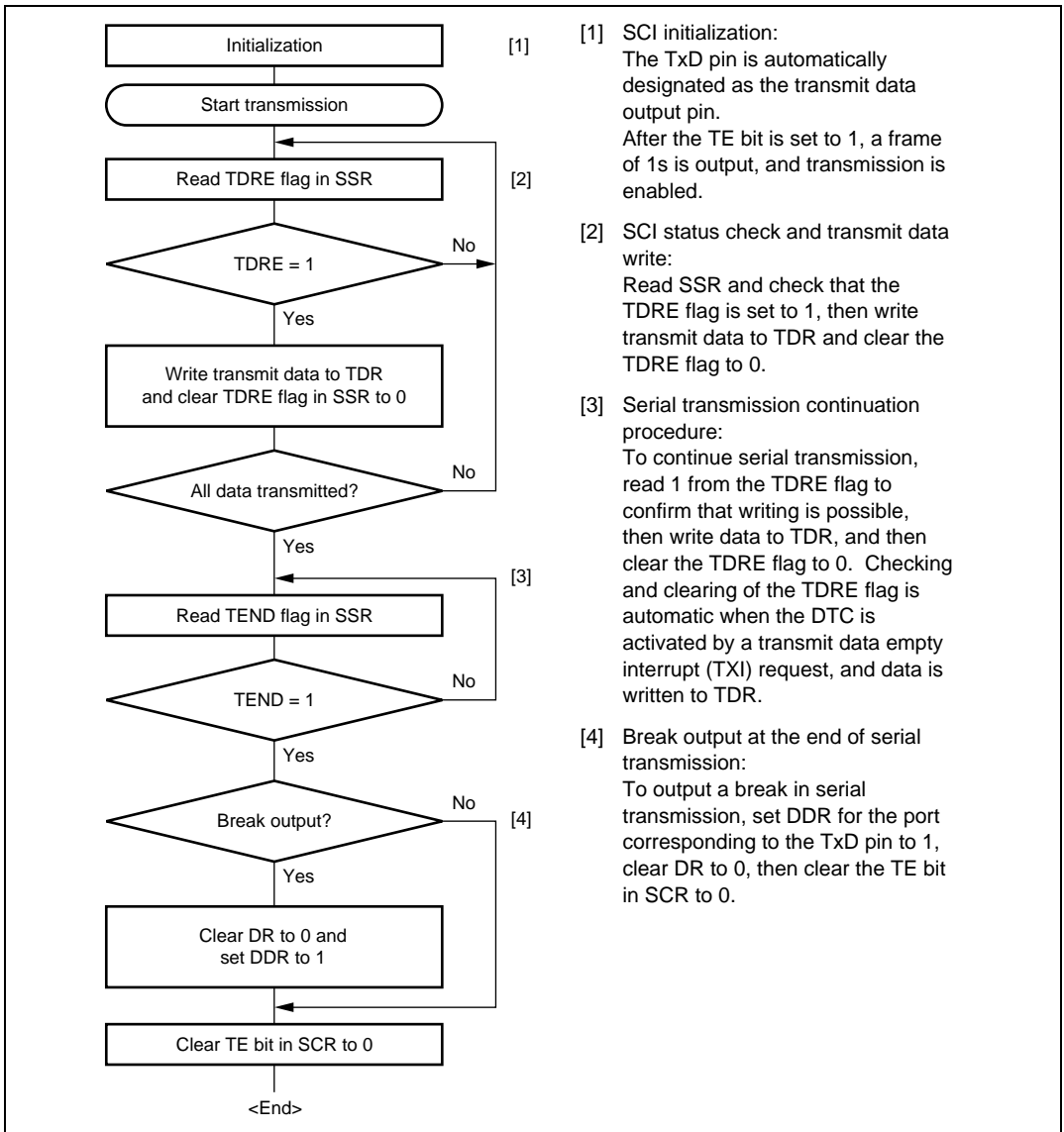
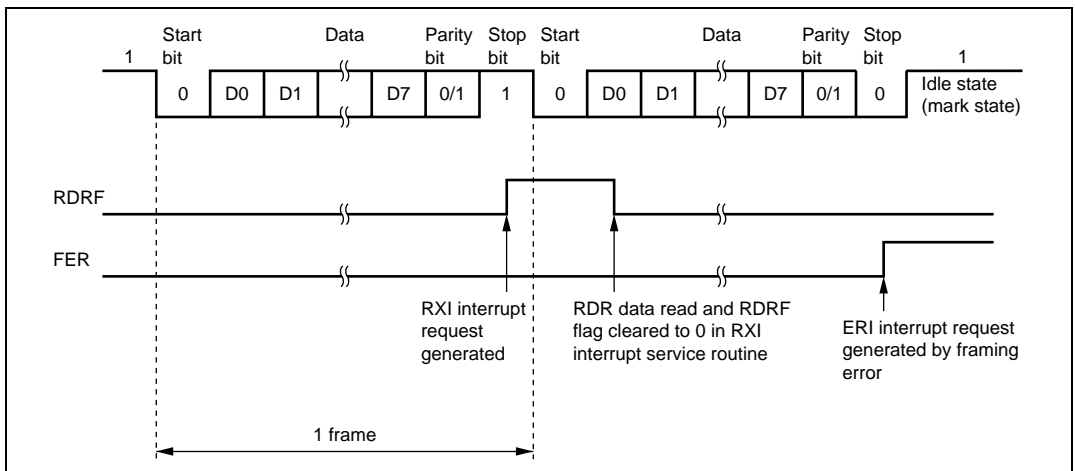

Figure 14.7 Sample Serial Transmission Flowchart

14.4.6 Serial Data Reception (Asynchronous Mode)

Figure 14.8 shows an example of operation for reception in asynchronous mode. In serial reception, the SCI operates as described below.

1. The SCI monitors the communication line. If a start bit is detected, the SCI performs internal synchronization, receives receive data in RSR, and checks the parity bit and stop bit.
2. If an overrun error occurs (when reception of the next data is completed while the RDRF flag is still set to 1), the ORER bit in SSR is set to 1. If the RIE bit in SCR is set to 1 at this time, an ERI interrupt request is generated. Receive data is not transferred to RDR. The RDRF flag remains to be set to 1.
3. If a parity error is detected, the PER bit in SSR is set to 1 and receive data is transferred to RDR. If the RIE bit in SCR is set to 1 at this time, an ERI interrupt request is generated.
4. If a framing error is detected (when the stop bit is 0), the FER bit in SSR is set to 1 and receive data is transferred to RDR. If the RIE bit in SCR is set to 1 at this time, an ERI interrupt request is generated.
5. If reception is completed successfully, the RDRF bit in SSR is set to 1, and receive data is transferred to RDR. If the RIE bit in SCR is set to 1 at this time, an RXI interrupt request is generated. Continuous reception is possible because the RXI interrupt routine reads the receive data transferred to RDR before reception of the next receive data has been completed.



**Figure 14.8 Example of SCI Operation in Reception
(Example with 8-Bit Data, Parity, One Stop Bit)**

Table 14.11 shows the states of the SSR status flags and receive data handling when a receive error is detected. If a receive error is detected, the RDRF flag retains its state before receiving data. Reception cannot be resumed while a receive error flag is set to 1. Accordingly, clear the ORER, FER, PER, and RDRF bits to 0 before resuming reception. Figure 14.9 shows a sample flowchart for serial data reception.

Table 14.11 SSR Status Flags and Receive Data Handling

SSR Status Flag				Receive Data	Receive Error Type
RDRF*	ORER	FER	PER		
1	1	0	0	Lost	Overrun error
0	0	1	0	Transferred to RDR	Framing error
0	0	0	1	Transferred to RDR	Parity error
1	1	1	0	Lost	Overrun error + framing error
1	1	0	1	Lost	Overrun error + parity error
0	0	1	1	Transferred to RDR	Framing error + parity error
1	1	1	1	Lost	Overrun error + framing error + parity error

Note: * The RDRF flag retains the state it had before data reception.

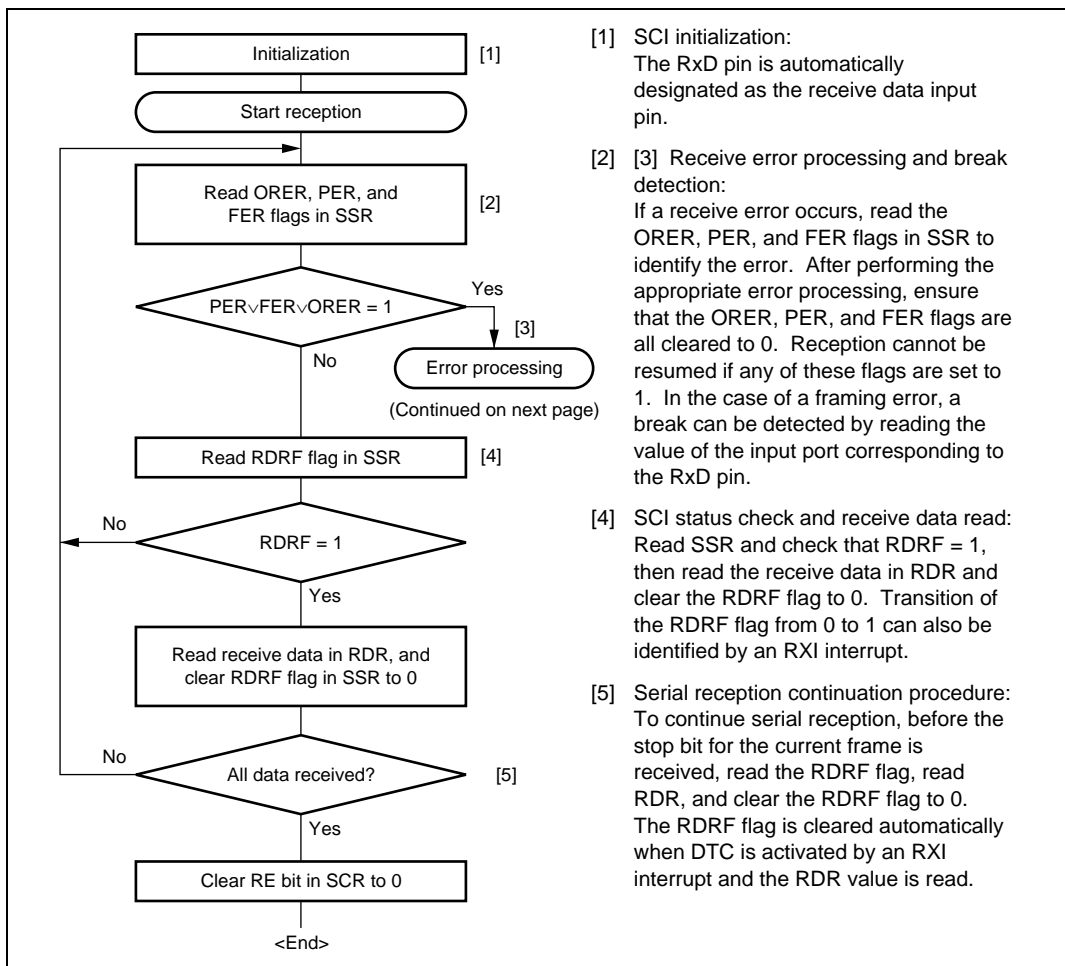

Figure 14.9 Sample Serial Reception Data Flowchart (1)

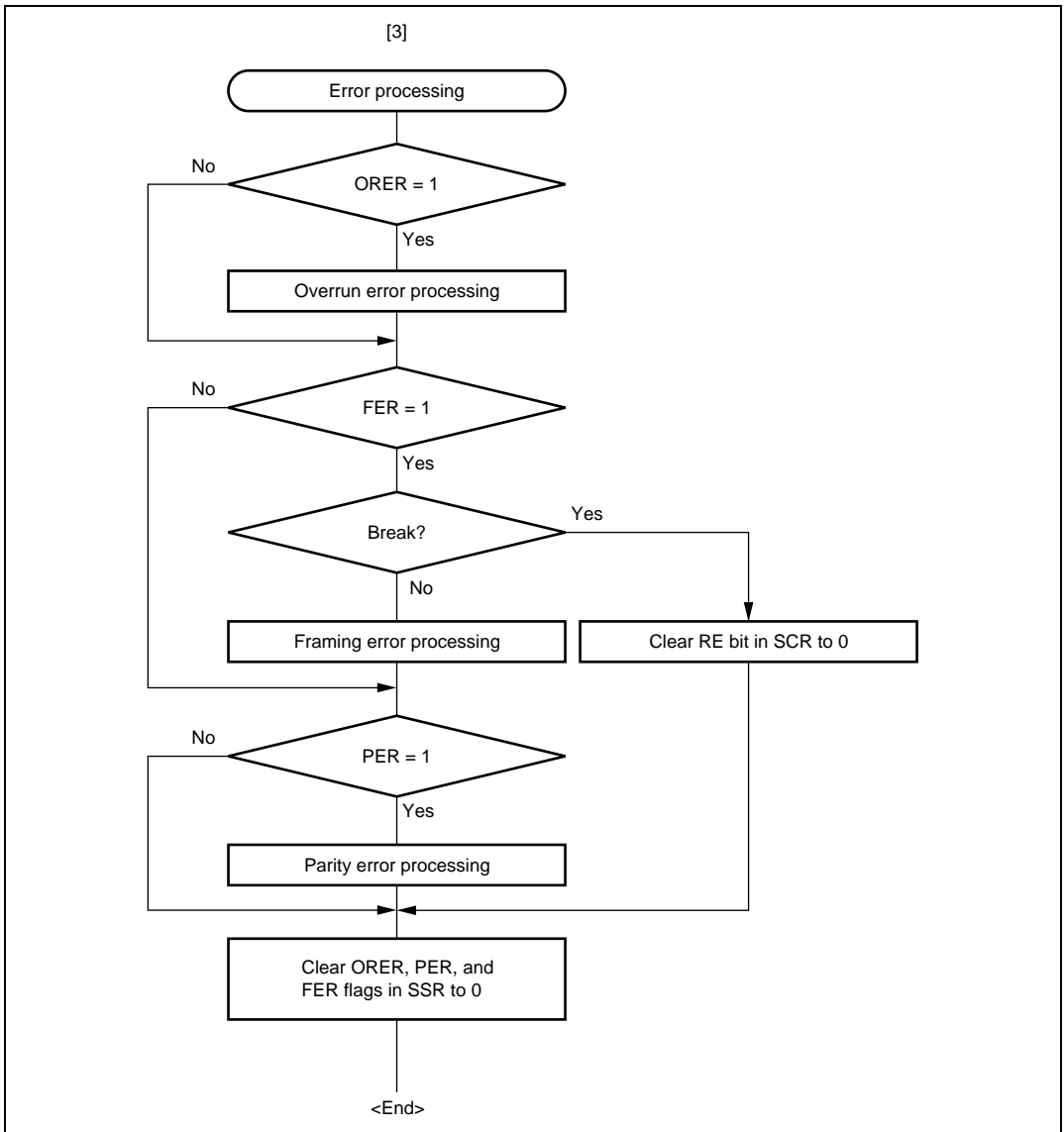

Figure 14.9 Sample Serial Reception Data Flowchart (2)

14.5 Multiprocessor Communication Function

Use of the multiprocessor communication function enables data transfer between a number of processors sharing communication lines by asynchronous serial communication using the multiprocessor format, in which a multiprocessor bit is added to the transfer data. When multiprocessor communication is performed, each receiving station is addressed by a unique ID code. The serial communication cycle consists of two component cycles; an ID transmission cycle that specifies the receiving station, and a data transmission cycle. The multiprocessor bit is used to differentiate between the ID transmission cycle and the data transmission cycle. If the multiprocessor bit is 1, the cycle is an ID transmission cycle; if the multiprocessor bit is 0, the cycle is a data transmission cycle. Figure 14.10 shows an example of inter-processor communication using the multiprocessor format. The transmitting station first sends the ID code of the receiving station with which it wants to perform serial communication as data with a 1 multiprocessor bit added. It then sends transmit data as data with a 0 multiprocessor bit added. When data with a 1 multiprocessor bit is received, the receiving station compares that data with its own ID. The station whose ID matches then receives the data sent next. Stations whose IDs do not match continue to skip data until data with a 1 multiprocessor bit is again received.

The SCI uses the MPIE bit in SCR to implement this function. When the MPIE bit is set to 1, transfer of receive data from RSR to RDR, error flag detection, and setting the SSR status flags, RDRF, FER, and ORER to 1, are inhibited until data with a 1 multiprocessor bit is received. On reception of a receive character with a 1 multiprocessor bit, the MPB bit in SSR is set to 1 and the MPIE bit is automatically cleared, thus normal reception is resumed. If the RIE bit in SCR is set to 1 at this time, an RXI interrupt is generated.

When the multiprocessor format is selected, the parity bit setting is rendered invalid. All other bit settings are the same as those in normal asynchronous mode. The clock used for multiprocessor communication is the same as that in normal asynchronous mode.

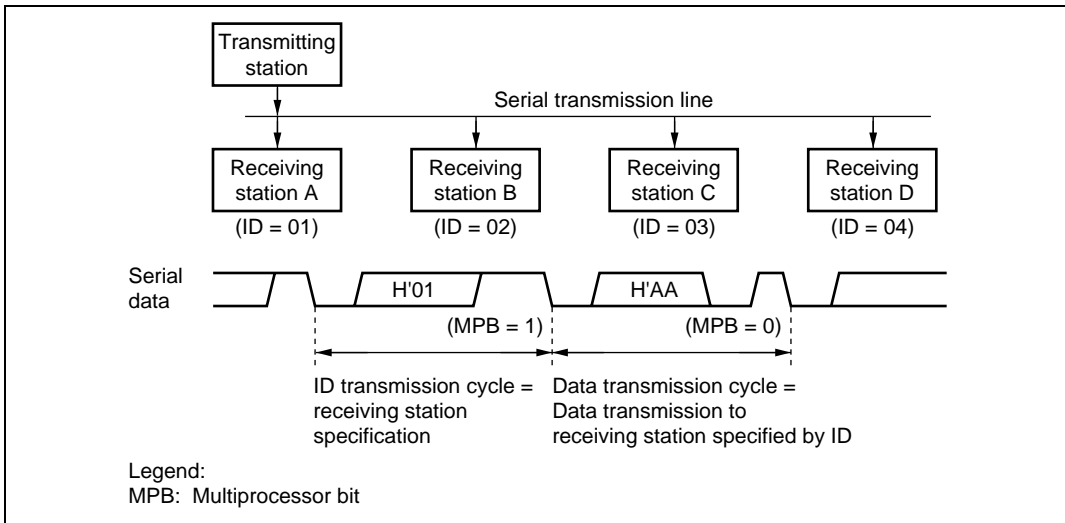

**Figure 14.10 Example of Communication Using Multiprocessor Format
(Transmission of Data H'AA to Receiving Station A)**

14.5.1 Multiprocessor Serial Data Transmission

Figure 14.11 shows a sample flowchart for multiprocessor serial data transmission. For an ID transmission cycle, set the MPBT bit in SSR to 1 before transmission. For a data transmission cycle, clear the MPBT bit in SSR to 0 before transmission. All other SCI operations are the same as those in asynchronous mode.

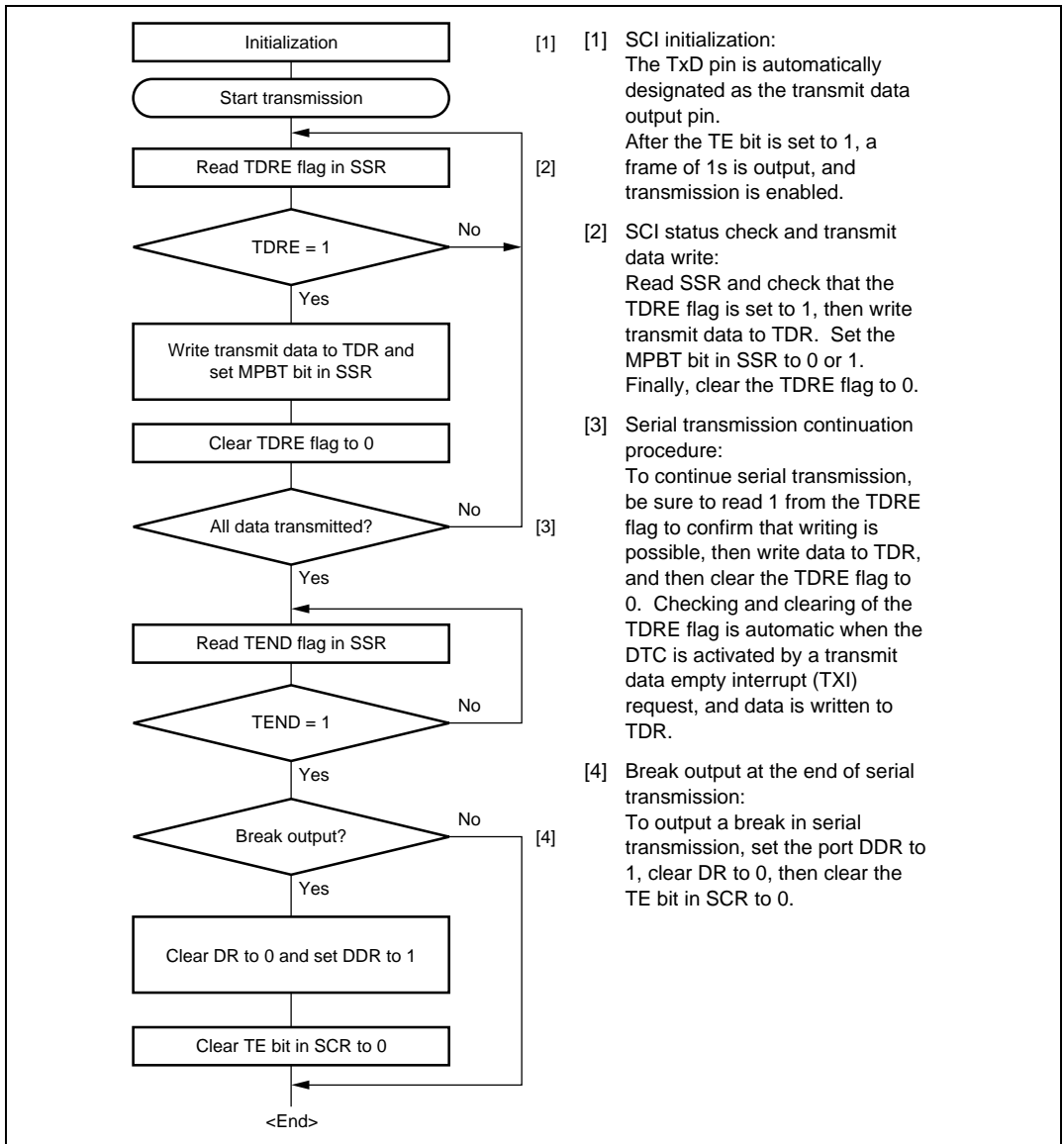
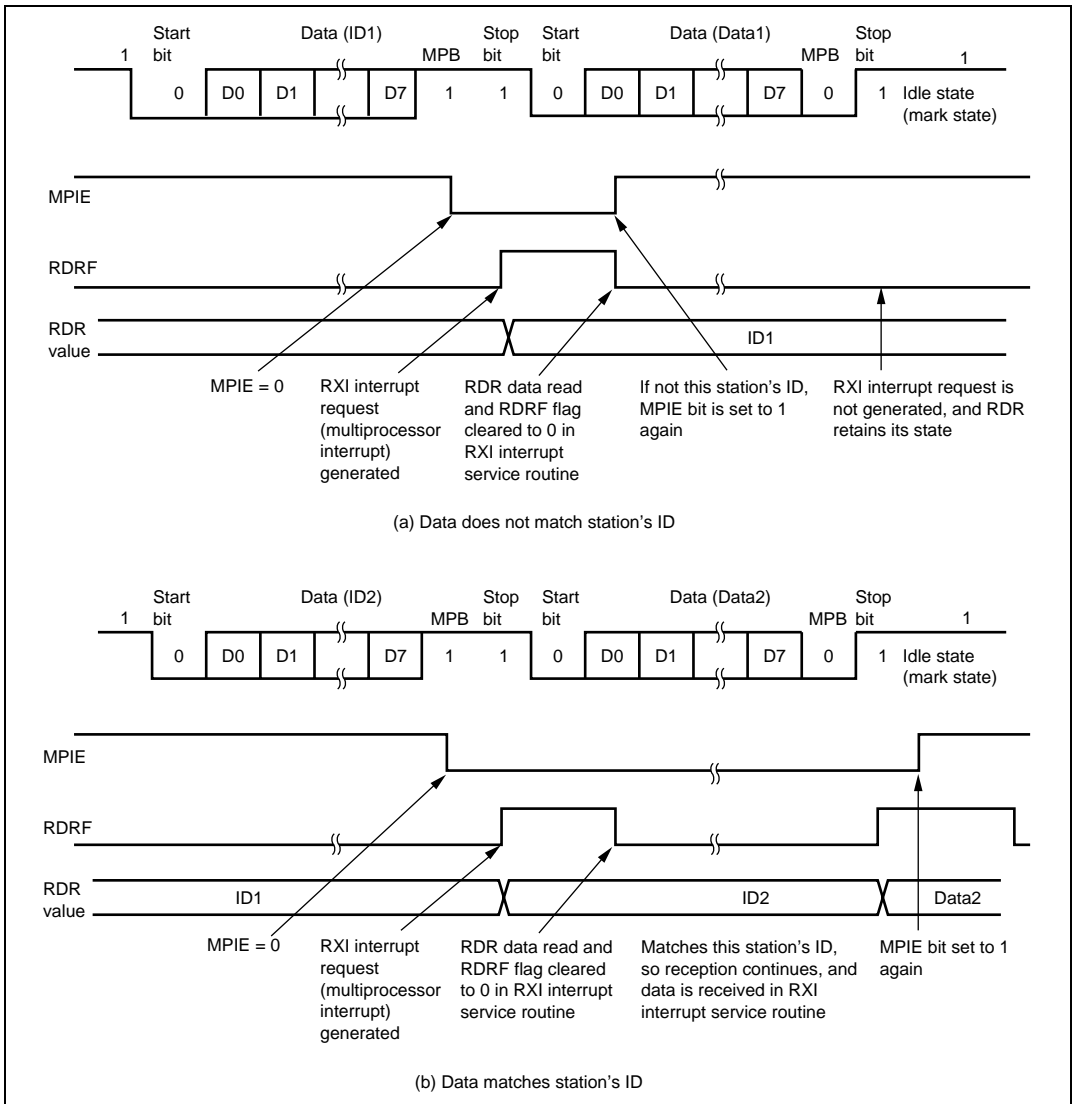

Figure 14.11 Sample Multiprocessor Serial Transmission Flowchart

14.5.2 Multiprocessor Serial Data Reception

Figure 14.13 shows a sample flowchart for multiprocessor serial data reception. If the MPIE bit in SCR is set to 1, data is skipped until data with a 1 multiprocessor bit is received. On receiving data

with a 1 multiprocessor bit, the receive data is transferred to RDR. An RXI interrupt request is generated at this time. All other SCI operations are the same as in asynchronous mode. Figure 14.12 shows an example of SCI operation for multiprocessor format reception.



**Figure 14.12 Example of SCI Operation in Reception
(Example with 8-Bit Data, Multiprocessor Bit, One Stop Bit)**

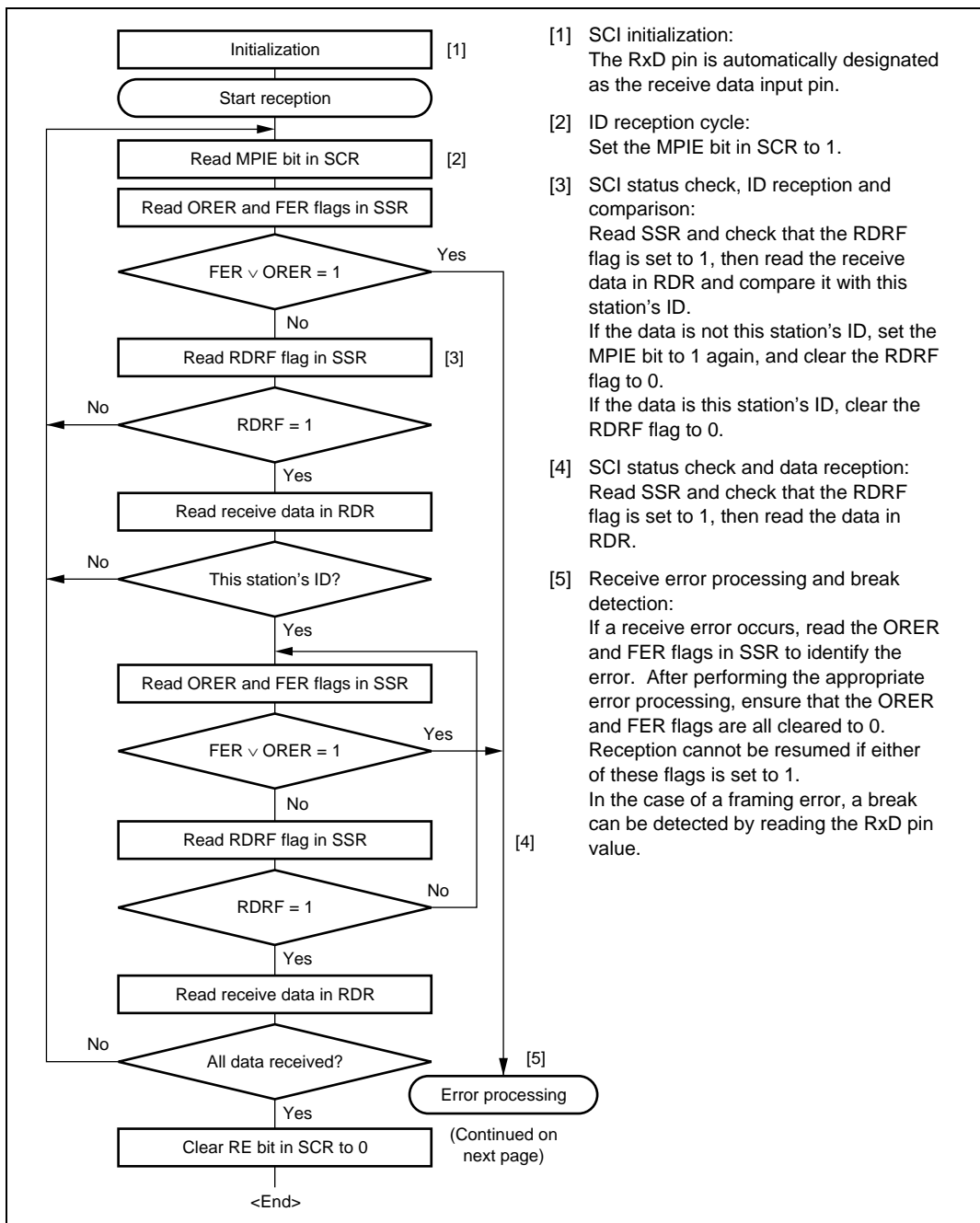
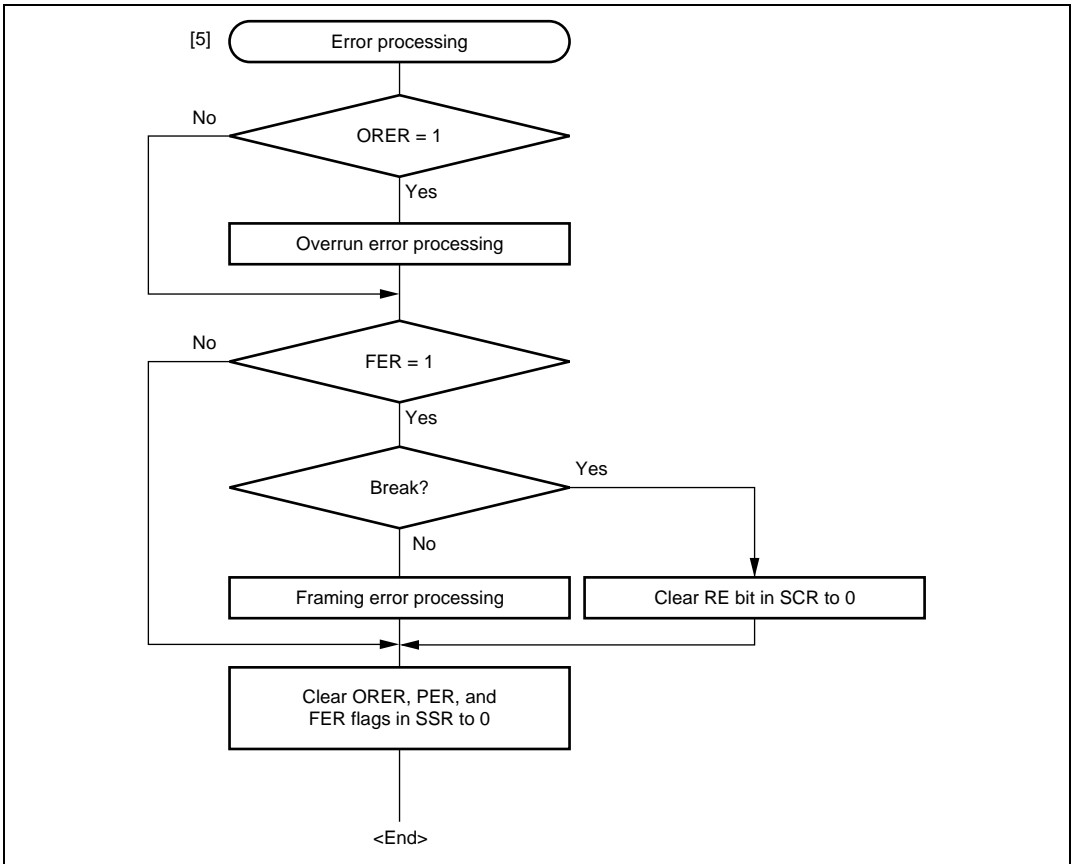

Figure 14.13 Sample Multiprocessor Serial Reception Flowchart (1)

**Figure 14.13 Sample Multiprocessor Serial Reception Flowchart (2)**

14.6 Operation in Clocked Synchronous Mode

Figure 14.14 shows the general format for clocked synchronous communication. In clocked synchronous mode, data is transmitted or received synchronous with clock pulses. Each character of data transferred consists of 8 bits. In clocked synchronous serial communication, data on the transmission line is output from one falling edge of the serial clock to the next. In clocked synchronous mode, the SCI receives data in synchronous with the rising edge of the serial clock. After 8-bit data is output, the transmission line holds the MSB state. In clocked synchronous mode, no parity or multiprocessor bit is added. Inside the SCI, the transmitter and receiver are independent units, enabling full-duplex communication through the use of a common clock. Both the transmitter and the receiver also have a double-buffered structure, so data can be read or written during transmission or reception, enabling continuous data transfer.

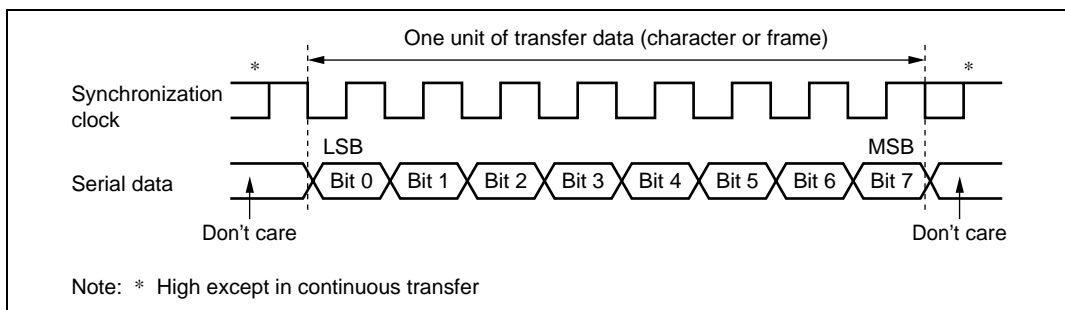

Figure 14.14 Data Format in Synchronous Communication (For LSB-First)

14.6.1 Clock

Either an internal clock generated by the on-chip baud rate generator or an external synchronization clock input at the SCK pin can be selected, according to the setting of CKE0 and CKE1 bits in SCR. When the SCI is operated on an internal clock, the serial clock is output from the SCK pin. Eight serial clock pulses are output in the transfer of one character, and when no transfer is performed the clock is fixed high.

14.6.2 SCI Initialization (Clocked Synchronous Mode)

Before transmitting and receiving data, the TE and RE bits in SCR should be cleared to 0, then the SCI should be initialized as described in a sample flowchart in figure 14.15. When the operating mode, or transfer format, is changed for example, the TE and RE bits must be cleared to 0 before making the change using the following procedure. When the TE bit is cleared to 0, the TDRE flag is set to 1. Note that clearing the RE bit to 0 does not change the contents of the RDRF, PER, FER, and ORER flags, or the contents of RDR.

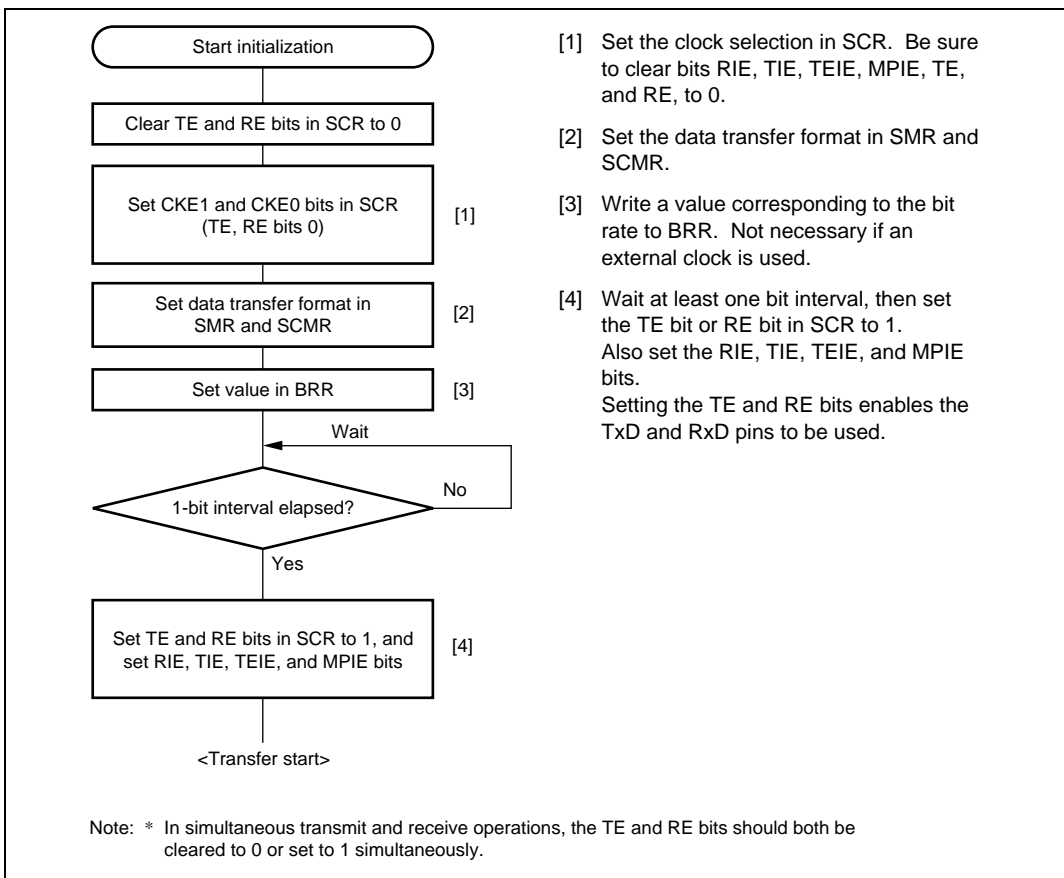

Figure 14.15 Sample SCI Initialization Flowchart

14.6.3 Serial Data Transmission (Clocked Synchronous Mode)

Figure 14.16 shows an example of SCI operation for transmission in clocked synchronous mode. In serial transmission, the SCI operates as described below.

1. The SCI monitors the TDRE flag in SSR, and if the flag is 0, the SCI recognizes that data has been written to TDR, and transfers the data from TDR to TSR.
2. After transferring data from TDR to TSR, the SCI sets the TDRE flag to 1 and starts transmission. If the TIE bit in SCR is set to 1 at this time, a transmit data empty interrupt (TXI) is generated. Continuous transmission is possible because the TXI interrupt routine writes the next transmit data to TDR before transmission of the current transmit data has been completed.
3. 8-bit data is sent from the TxD pin synchronized with the output clock when output clock mode has been specified, and synchronized with the input clock when use of an external clock has been specified.
4. The SCI checks the TDRE flag at the timing for sending the MSB (bit 7).
5. If the TDRE flag is cleared to 0, data is transferred from TDR to TSR, and serial transmission of the next frame is started.
6. If the TDRE flag is set to 1, the TEND flag in SSR is set to 1, and the TDRE flag maintains the output state of the last bit. If the TEIE bit in SCR is set to 1 at this time, a TEI interrupt request is generated. The SCK pin is fixed high.

Figure 14.17 shows a sample flow chart for serial data transmission. Even if the TDRE flag is cleared to 0, transmission will not start while a receive error flag (ORER, FER, or PER) is set to 1. Make sure that the receive error flags are cleared to 0 before starting transmission. Note that clearing the RE bit to 0 does not clear the receive error flags.

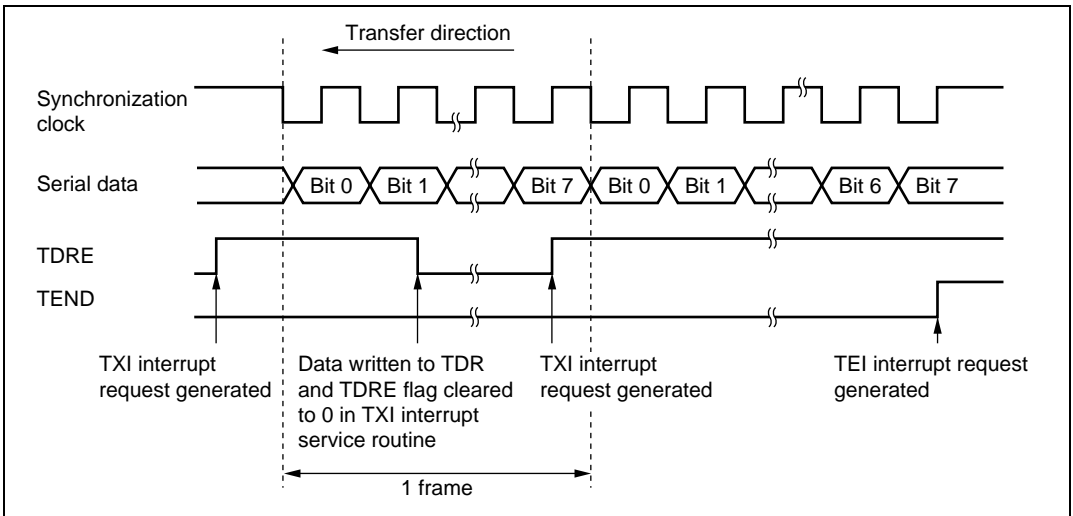

Figure 14.16 Sample SCI Transmission Operation in Clocked Synchronous Mode

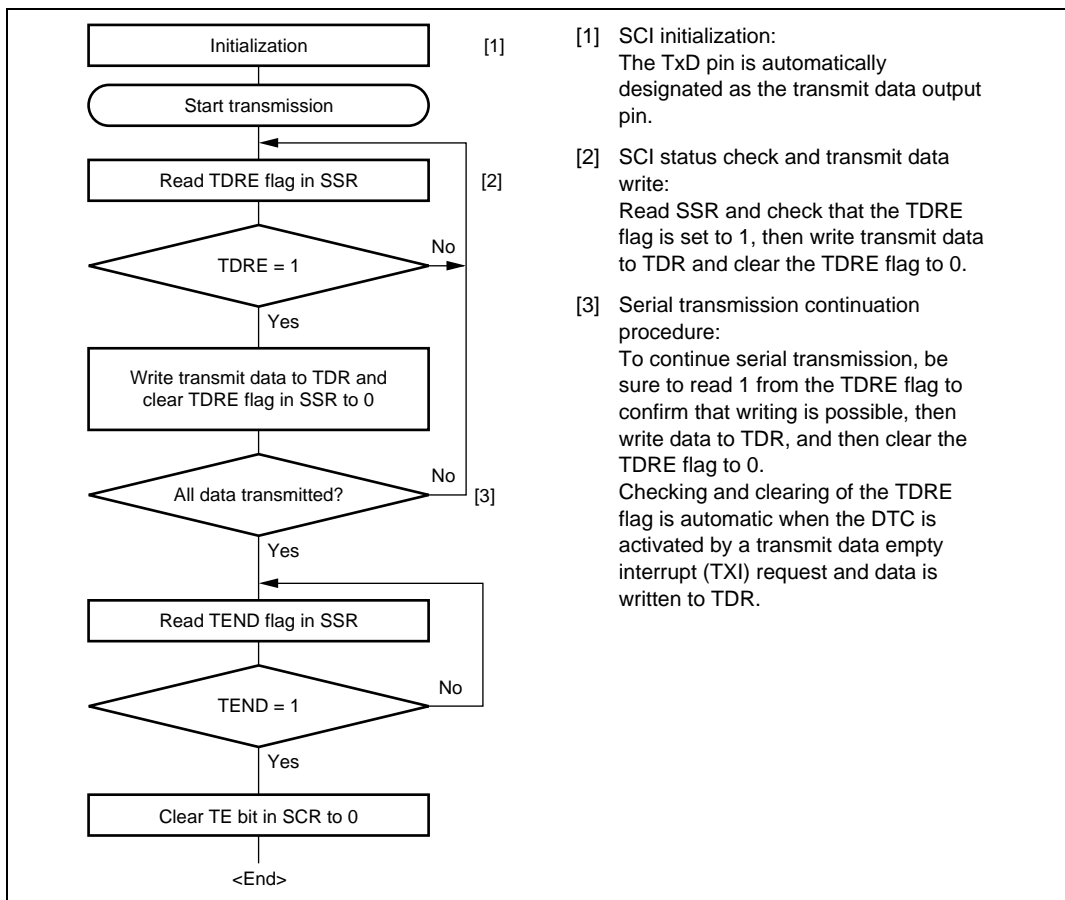

Figure 14.17 Sample Serial Transmission Flowchart

14.6.4 Serial Data Reception (Clocked Synchronous Mode)

Figure 14.18 shows an example of SCI operation for reception in clocked synchronous mode. In serial reception, the SCI operates as described below.

1. The SCI performs internal initialization synchronous with a synchronous clock input or output, starts receiving data, and stores the received data in RSR.
2. If an overrun error occurs (when reception of the next data is completed while the RDRF flag in SSR is still set to 1), the ORER bit in SSR is set to 1. If the RIE bit in SCR is set to 1 at this time, an ERI interrupt request is generated, receive data is not transferred to RDR, and the RDRF flag remains to be set to 1.
3. If reception is completed successfully, the RDRF bit in SSR is set to 1, and receive data is transferred to RDR. If the RIE bit in SCR is set to 1 at this time, an RXI interrupt request is generated. Continuous reception is possible because the RXI interrupt routine reads the receive data transferred to RDR before reception of the next receive data has finished.

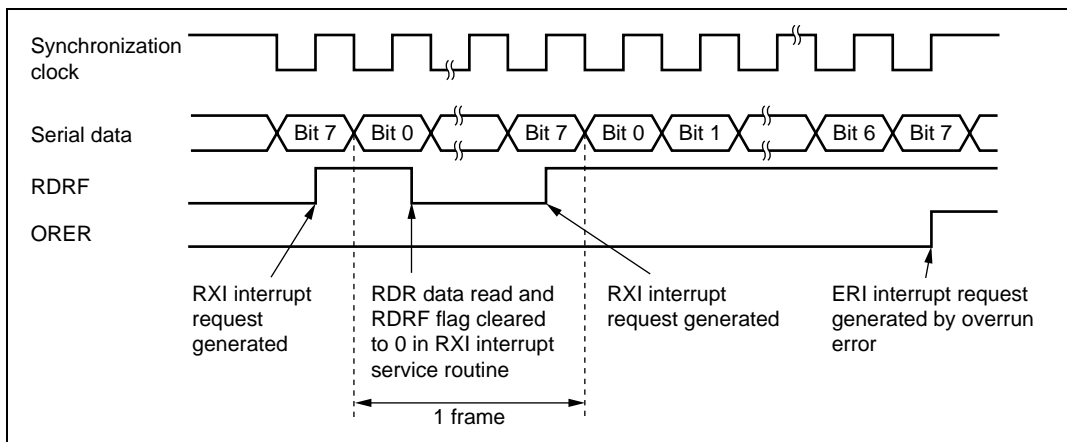

Figure 14.18 Example of SCI Operation in Reception

Reception cannot be resumed while a receive error flag is set to 1. Accordingly, clear the ORER, FER, PER, and RDRF bits to 0 before resuming reception. Figure 14.19 shows a sample flow chart for serial data reception.

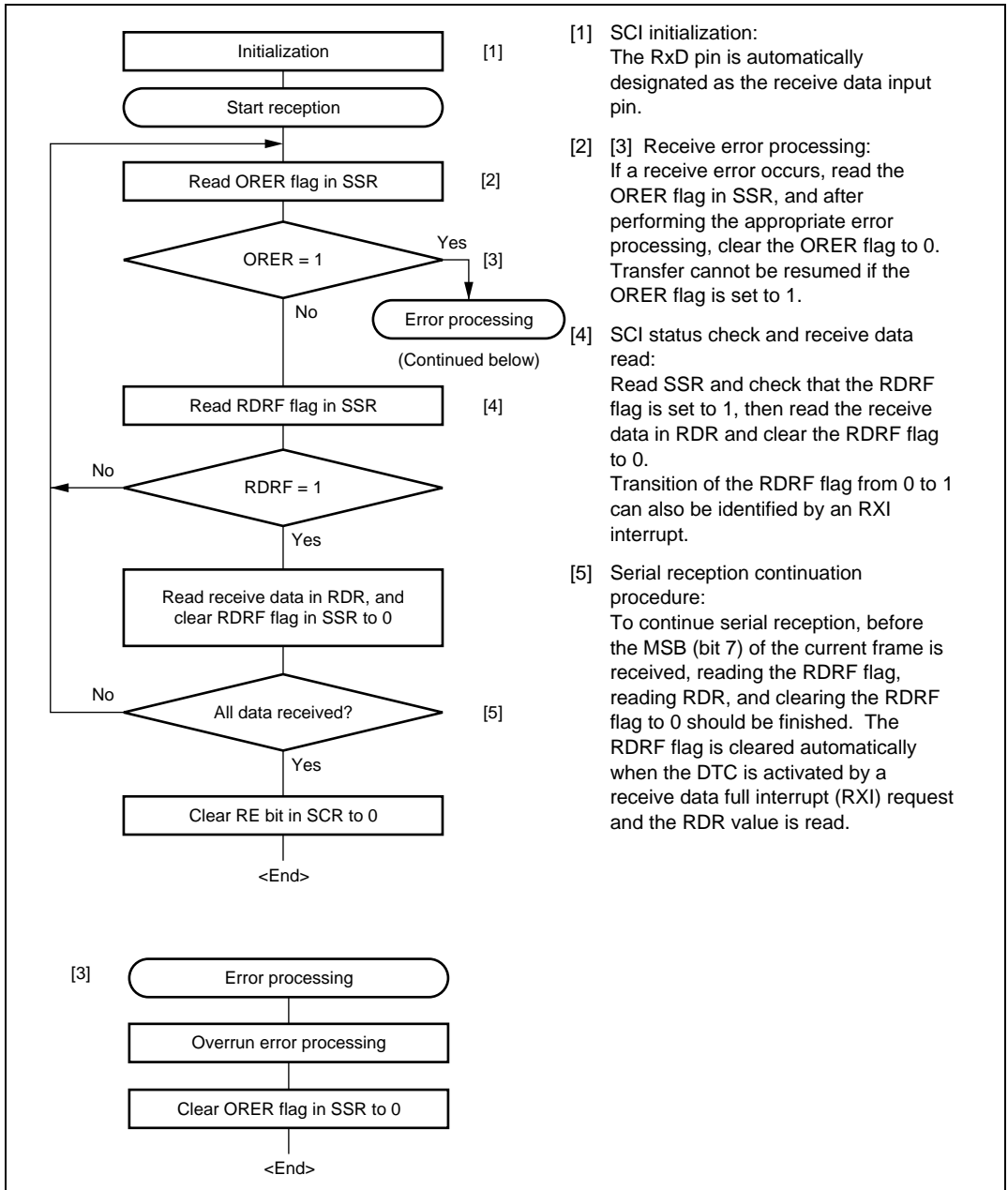

Figure 14.19 Sample Serial Reception Flowchart

14.6.5 Simultaneous Serial Data Transmission and Reception (Clocked Synchronous Mode)

Figure 14.20 shows a sample flowchart for simultaneous serial transmit and receive operations. The following procedure should be used for simultaneous serial data transmit and receive operations after initializing the SCI. To switch from transmit mode to simultaneous transmit and receive mode, after checking that the SCI has finished transmission and the TDRE and TEND flags are set to 1, clear TE to 0. Then simultaneously set TE and RE to 1 with a single instruction. To switch from receive mode to simultaneous transmit and receive mode, after checking that the SCI has finished reception, clear RE to 0. Then after checking that the RDRF and receive error flags (ORER, FER, and PER) are cleared to 0, simultaneously set TE and RE to 1 with a single instruction.

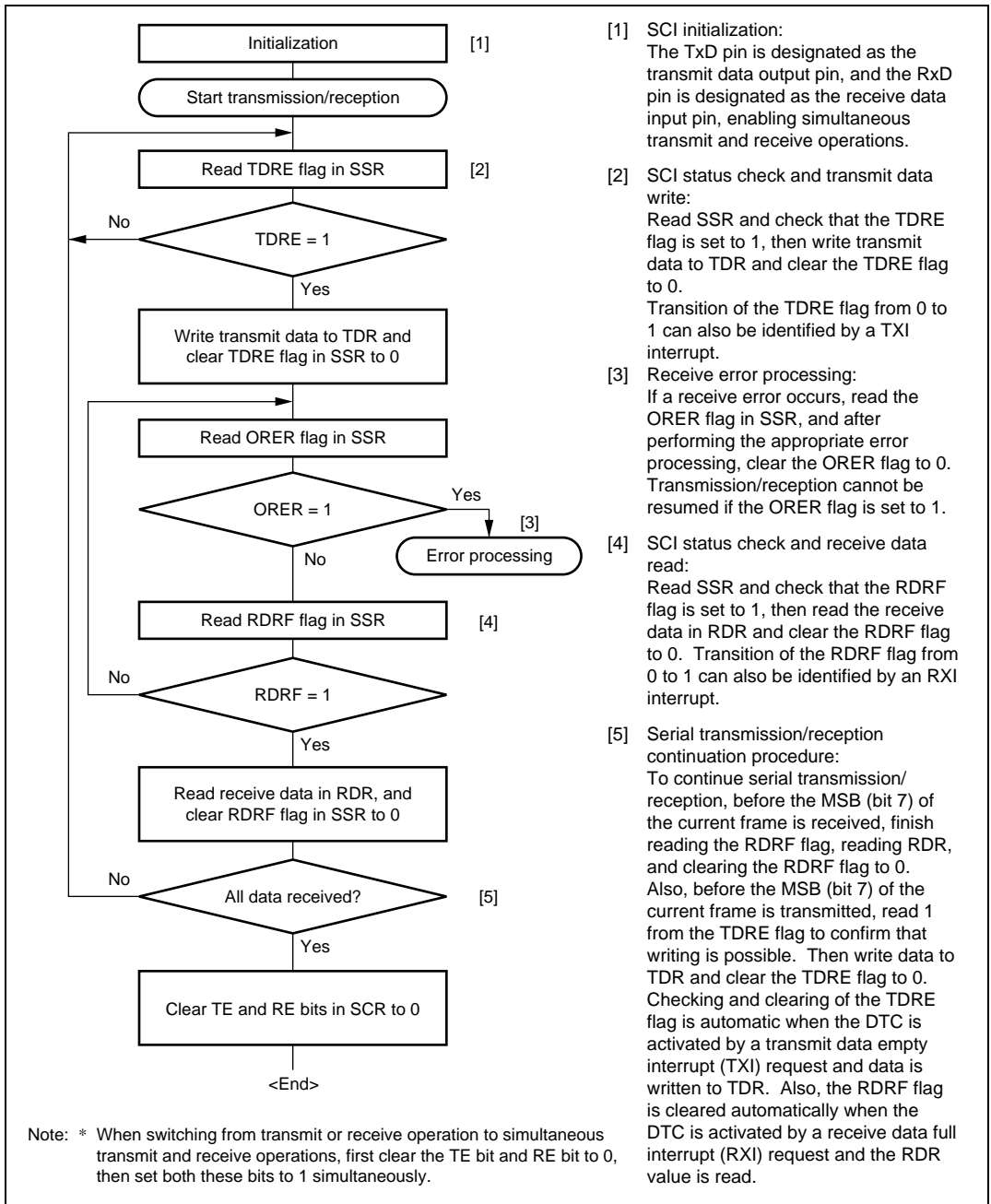

Figure 14.20 Sample Flowchart of Simultaneous Serial Transmit and Receive Operations

14.7 Operation in Smart Card Interface

The SCI supports an IC card (Smart Card) interface that conforms to ISO/IEC 7816-3 (Identification Card) as a serial communication interface extension function. Switching between the normal serial communication interface and the Smart Card interface mode is carried out by means of a register setting.

14.7.1 Pin Connection Example

Figure 14.21 shows an example of connection with the Smart Card. In communication with an IC card, as both transmission and reception are carried out on a single data transmission line, the TxD pin and RxD pin should be connected to the LSI pin. The data transmission line should be pulled up to the V_{CC} power supply with a resistor. If an IC card is not connected, and the TE and RE bits are both set to 1, closed transmission/reception is possible, enabling self-diagnosis to be carried out. When the clock generated on the Smart Card interface is used by an IC card, the SCK pin output is input to the CLK pin of the IC card. This LSI port output is used as the reset signal.

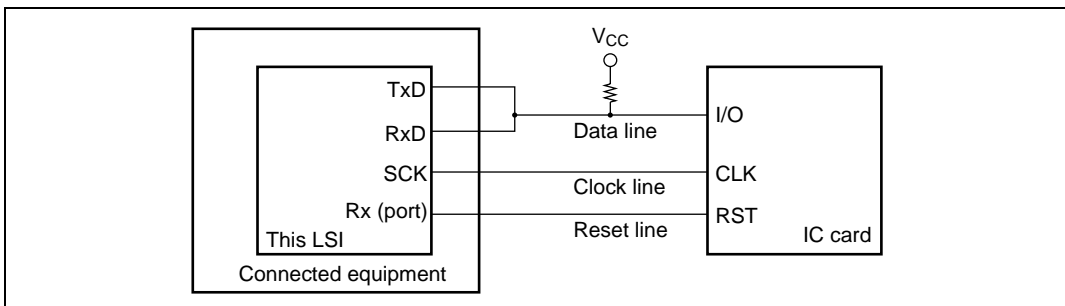

Figure 14.21 Schematic Diagram of Smart Card Interface Pin Connections

14.7.2 Data Format (Except for Block Transfer Mode)

Figure 14.22 shows the transfer data format in Smart Card interface mode.

- One frame consists of 8-bit data plus a parity bit in asynchronous mode.
- In transmission, a guard time of at least 2 etu (Elementary Time Unit: the time for transfer of one bit) is left between the end of the parity bit and the start of the next frame.
- If a parity error is detected during reception, a low error signal level is output for one etu period, 10.5 etu after the start bit.
- If an error signal is sampled during transmission, the same data is retransmitted automatically after a delay of 2 etu or longer.

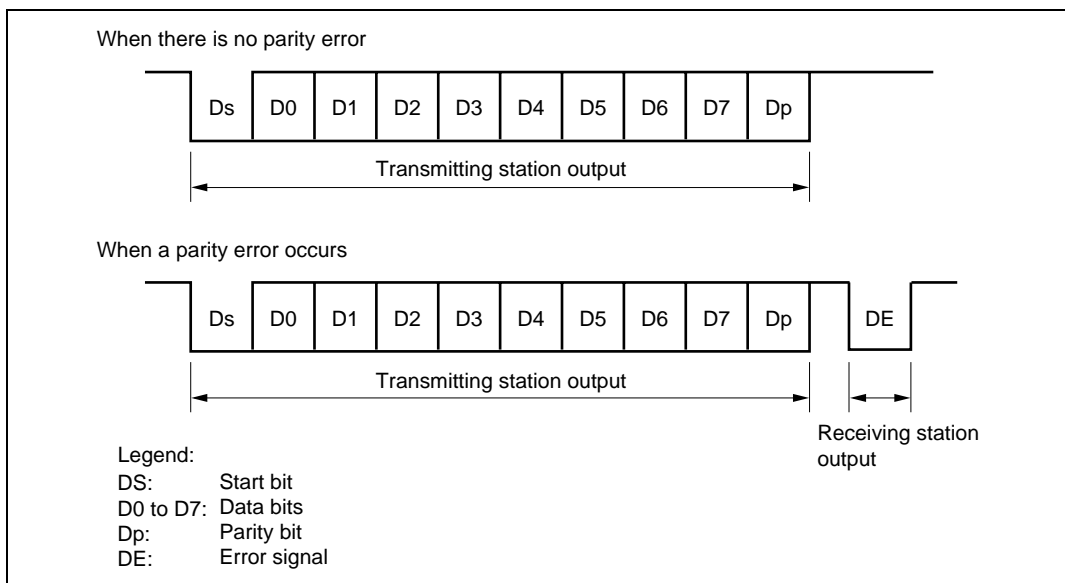

Figure 14.22 Normal Smart Card Interface Data Format

Data transfer with other types of IC cards (direct convention and inverse convention) are performed as described in the following.

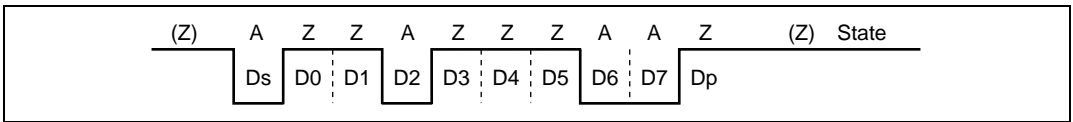

Figure 14.23 Direct Convention (SDIR = SINV = $\overline{O/E} = 0$)

With the direction convention type IC and the above sample start character, the logic 1 level corresponds to state Z and the logic 0 level to state A, and transfer is performed in LSB-first order. The start character data above is H'3B. For the direct convention type, clear the SDIR and SINV bits in SCMR to 0. According to Smart Card regulations, clear the $\overline{O/E}$ bit in SMR to 0 to select even parity mode.

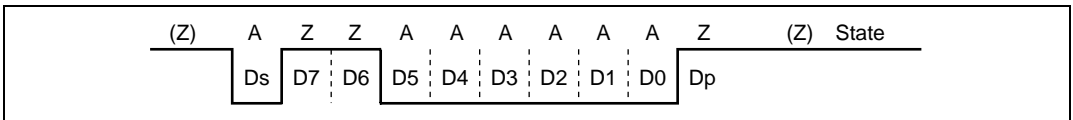

Figure 14.24 Inverse Convention (SDIR = SINV = $\overline{O/E} = 1$)

With the inverse convention type, the logic 1 level corresponds to state A and the logic 0 level to state Z, and transfer is performed in MSB-first order. The start character data for the above is H'3F. For the inverse convention type, set the SDIR and SINV bits in SCMR to 1. According to Smart Card regulations, even parity mode is the logic 0 level of the parity bit, and corresponds to state Z. In this LSI, the SINV bit inverts only data bits D7 to D0. Therefore, set the $\overline{O/E}$ bit in SMR to 1 to invert the parity bit for both transmission and reception.

14.7.3 Block Transfer Mode

Operation in block transfer mode is the same as that in SCI asynchronous mode, except for the following points.

- In reception, though the parity check is performed, no error signal is output even if an error is detected. However, the PER bit in SSR is set to 1 and must be cleared before receiving the parity bit of the next frame.
- In transmission, a guard time of at least 1 etu is left between the end of the parity bit and the start of the next frame.
- In transmission, because retransmission is not performed, the TEND flag is set to 1, 11.5 etu after transmission start.
- As with the normal Smart Card interface, the ERS flag indicates the error signal status, but since error signal transfer is not performed, this flag is always cleared to 0.

14.7.4 Receive Data Sampling Timing and Reception Margin in Smart Card Interface Mode

In Smart Card interface mode, the SCI operates on a basic clock with a frequency of 32, 64, 372, or 256 times the transfer rate (fixed at 16 times in normal asynchronous mode) as determined by bits BCP1 and BCP0. In reception, the SCI samples the falling edge of the start bit using the basic clock, and performs internal synchronization. As shown in figure 14.25, by sampling receive data at the rising-edge of the 16th, 32nd, 186th, or 128th pulse of the basic clock, data can be latched at the middle of the bit. The reception margin is given by the following formula.

$$M = \left| \left(0.5 - \frac{1}{2N} \right) - (L - 0.5) F - \frac{|D - 0.5|}{N} (1 + F) \right| \times 100\%$$

Where M: Reception margin (%)

N: Ratio of bit rate to clock (N = 32, 64, 372, and 256)

D: Clock duty cycle (D = 0 to 1.0)

L: Frame length (L = 10)

F: Absolute value of clock frequency deviation

Assuming values of F = 0, D = 0.5 and N = 372 in the above formula, the reception margin formula is as follows.

$$\begin{aligned} M &= (0.5 - 1/2 \times 372) \times 100\% \\ &= 49.866\% \end{aligned}$$

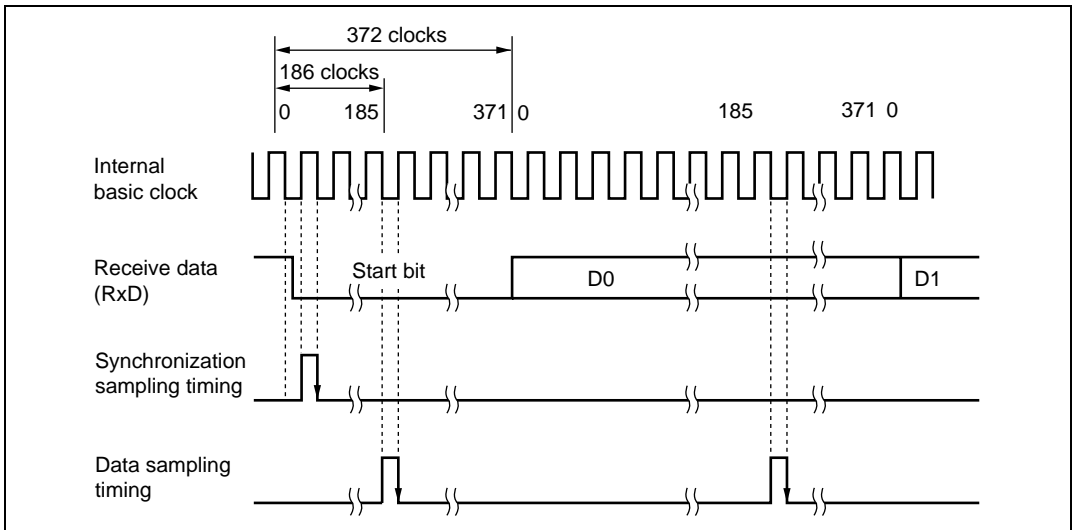

**Figure 14.25 Receive Data Sampling Timing in Smart Card Mode
(Using Clock of 372 Times the Transfer Rate)**

14.7.5 Initialization

Before transmitting and receiving data, initialize the SCI as described below. Initialization is also necessary when switching from transmit mode to receive mode, or vice versa.

1. Clear the TE and RE bits in SCR to 0.
2. Clear the error flags ERS, PER, and ORER in SSR to 0.
3. Set the GM, BLK, O/ \bar{E} , BCP0, BCP1, CKS0, CKS1 bits in SMR. Set the PE bit to 1.
4. Set the SMIF, SDIR, and SINV bits in SCMR.

When the SMIF bit is set to 1, the TxD and RxD pins are both switched from ports to SCI pins, and are placed in the high-impedance state.

5. Set the value corresponding to the bit rate in BRR.
6. Set the CKE0 and CKE1 bits in SCR. Clear the TIE, RIE, TE, RE, MPIE, and TEIE bits to 0.
If the CKE0 bit is set to 1, the clock is output from the SCK pin.
7. Wait at least one bit interval, then set the TIE, RIE, TE, and RE bits in SCR. Do not set the TE bit and RE bit at the same time, except for self-diagnosis.

To switch from receive mode to transmit mode, after checking that the SCI has finished reception, initialize the SCI, and set RE to 0 and TE to 1. Whether SCI has finished reception or not can be checked with the RDRF, PER, or ORER flags. To switch from transmit mode to receive mode,

after checking that the SCI has finished transmission, initialize the SCI, and set TE to 0 and RE to 1. Whether SCI has finished transmission or not can be checked with the TEND flag.

14.7.6 Data Transmission (Except for Block Transfer Mode)

As data transmission in Smart Card interface mode involves error signal sampling and retransmission processing, the operations are different from those in normal serial communication interface mode (except for block transfer mode). Figure 14.26 illustrates the retransfer operation when the SCI is in transmit mode.

1. If an error signal is sent back from the receiving end after transmission of one frame is complete, the ERS bit in SSR is set to 1. If the RIE bit in SCR is enabled at this time, an ERI interrupt request is generated. The ERS bit in SSR should be kept cleared to 0 until the next parity bit is sampled.
2. The TEND bit in SSR is not set for a frame in which an error signal indicating an abnormality is received. Data is retransferred from TDR to TSR, and retransmitted automatically.
3. If an error signal is not sent back from the receiving end, the ERS bit in SSR is not set. Transmission of one frame, including a retransfer, is judged to have been completed, and the TEND bit in SSR is set to 1. If the TIE bit in SCR is enabled at this time, a TXI interrupt request is generated. Writing transmit data to TDR transfers the next transmit data.

Figure 14.28 shows a flowchart for transmission. The sequence of transmit operations can be performed automatically by specifying the DTC to be activated with a TXI interrupt source. In a transmit operation, the TDRE flag is set to 1 at the same time as the TEND flag in SSR is set, and a TXI interrupt will be generated if the TIE bit in SCR has been set to 1. If the TXI request is designated beforehand as a DTC activation source, the DTC will be activated by the TXI request, and transfer of the transmit data will be carried out. The TDRE and TEND flags are automatically cleared to 0 when data is transferred by the DTC. In the event of an error, the SCI retransmits the same data automatically. During this period, the TEND flag remains cleared to 0 and the DTC is not activated. Therefore, the SCI and DTC will automatically transmit the specified number of bytes in the event of an error, including retransmission. However, the ERS flag is not cleared automatically when an error occurs, and so the RIE bit should be set to 1 beforehand so that an ERI request will be generated in the event of an error, and the ERS flag will be cleared.

When performing transfer using the DTC, it is essential to set and enable the DTC before carrying out SCI setting. For details of the DTC setting procedures, refer to section 8, Data Transfer Controller (DTC).

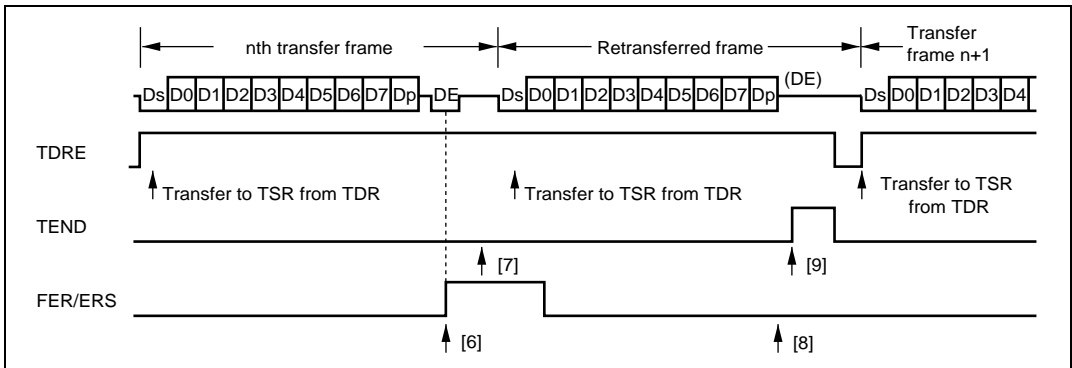

Figure 14.26 Retransfer Operation in SCI Transmit Mode

The timing for setting the TEND flag depends on the value of the GM bit in SMR. The TEND flag set timing is shown in figure 14.27.

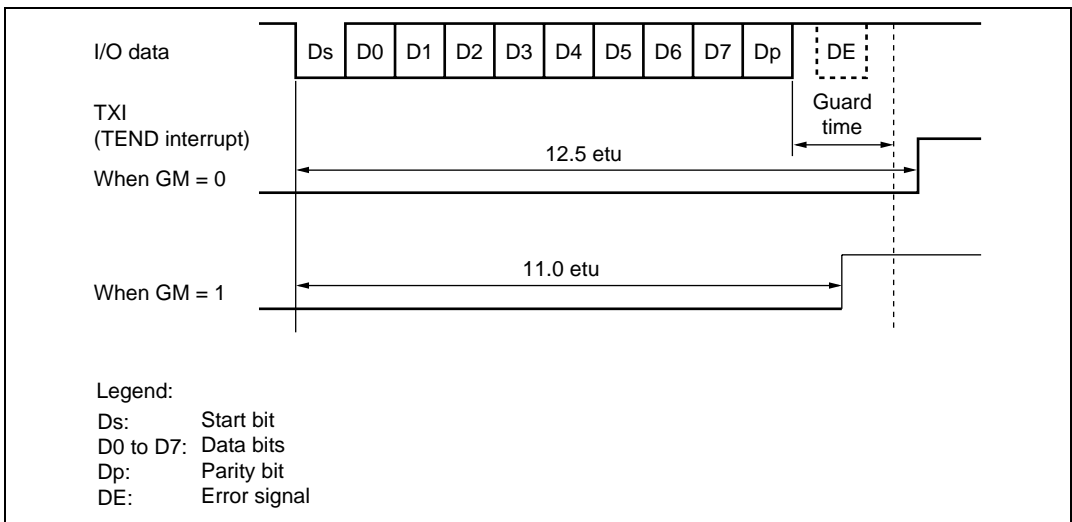

Figure 14.27 TEND Flag Generation Timing in Transmission Operation

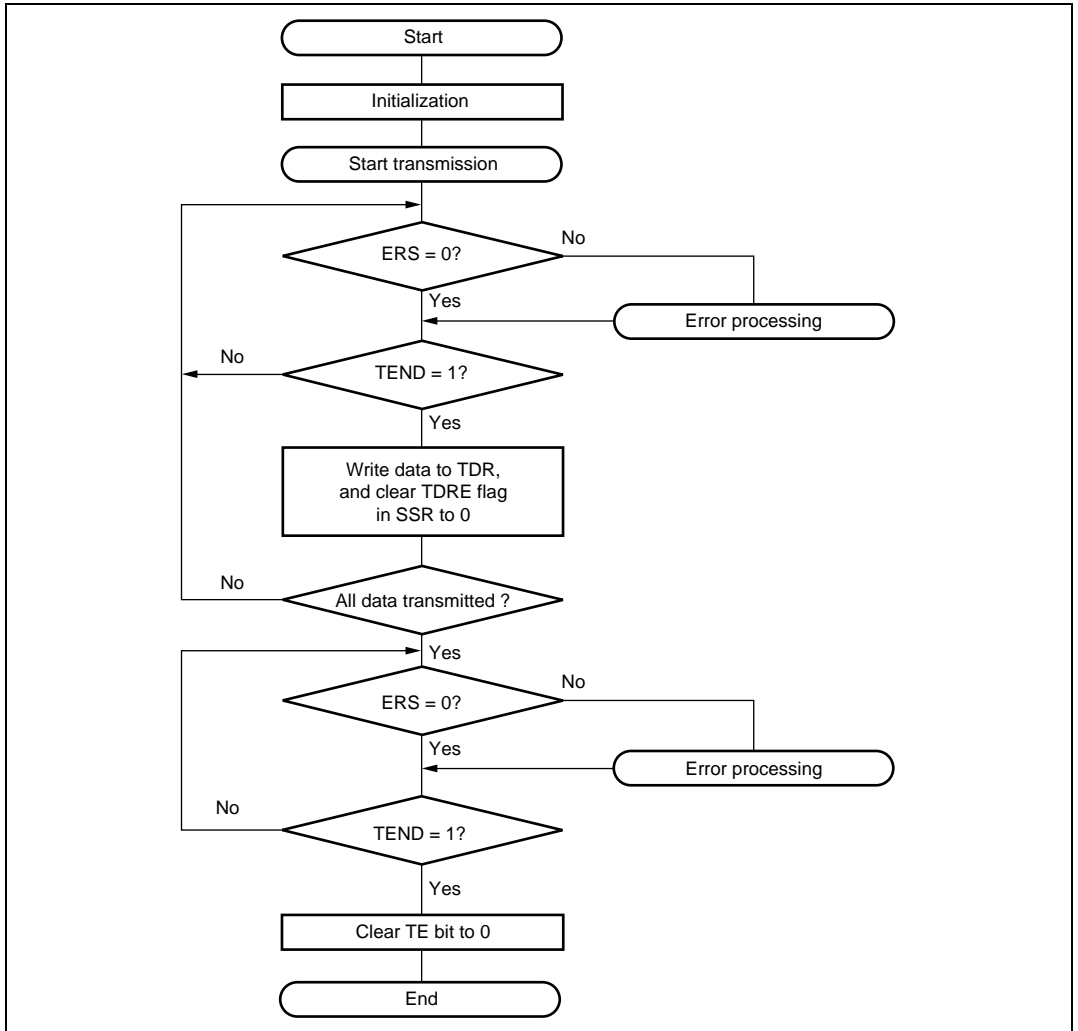

Figure 14.28 Example of Transmission Processing Flow

14.7.7 Serial Data Reception (Except for Block Transfer Mode)

Data reception in Smart Card interface mode uses the same operation procedure as for normal serial communication interface mode. Figure 14.29 illustrates the retransfer operation when the SCI is in receive mode.

1. If an error is found when the received parity bit is checked, the PER bit in SSR is automatically set to 1. If the RIE bit in SCR is set at this time, an ERI interrupt request is generated. The PER bit in SSR should be kept cleared to 0 until the next parity bit is sampled.
2. The RDRF bit in SSR is not set for a frame in which an error has occurred.
3. If no error is found when the received parity bit is checked, the PER bit in SSR is not set to 1, the receive operation is judged to have been completed normally, and the RDRF flag in SSR is automatically set to 1. If the RIE bit in SCR is enabled at this time, an RXI interrupt request is generated.

Figure 14.30 shows a flowchart for reception. A sequence of receive operations can be performed automatically by specifying the DTC to be activated using an RXI interrupt source. In a receive operation, an RXI interrupt request is generated when the RDRF flag is set to 1 if the RIE bit is set to 1. If the RXI request is designated beforehand as a DTC activation source, the DTC will be activated by the RXI request, and the receive data will be transferred. The RDRF flag is cleared to 0 automatically when data is transferred by the DTC. If an error occurs in receive mode and the ORER or PER flag is set to 1, a transfer error interrupt (ERI) request will be generated. Hence, so the error flag must be cleared to 0. In the event of an error, the DTC is not activated and receive data is skipped. Therefore, receive data is transferred for only the specified number of bytes in the event of an error. Even when a parity error occurs in receive mode and the PER flag is set to 1, the data that has been received is transferred to RDR and can be read from there.

Note: For details on receive operations in block transfer mode, refer to 14.4, Operation in Asynchronous Mode.

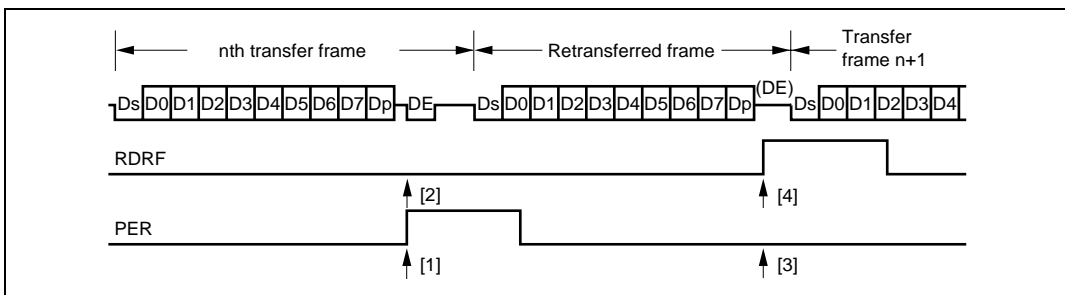

Figure 14.29 Retransfer Operation in SCI Receive Mode

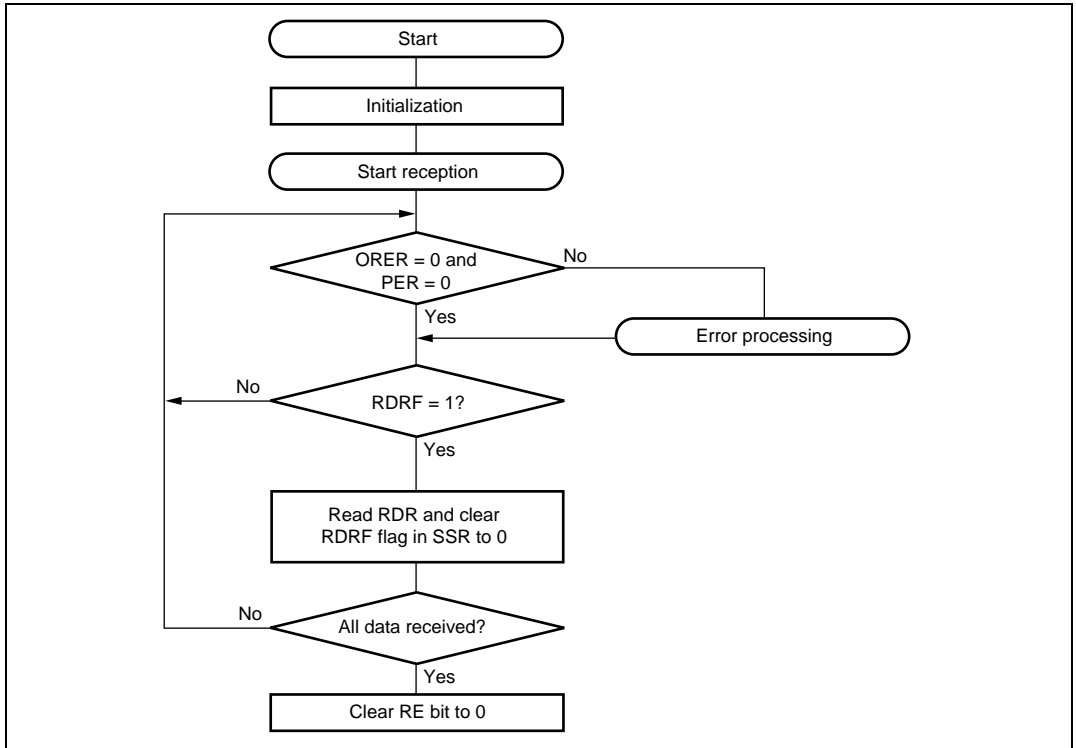

Figure 14.30 Example of Reception Processing Flow

14.7.8 Clock Output Control

When the GM bit in SMR is set to 1, the clock output level can be fixed with bits CKE0 and CKE1 in SCR. At this time, the minimum clock pulse width can be made the specified width. Figure 14.31 shows the timing for fixing the clock output level. In this example, GM is set to 1, CKE1 is cleared to 0, and the CKE0 bit is controlled.

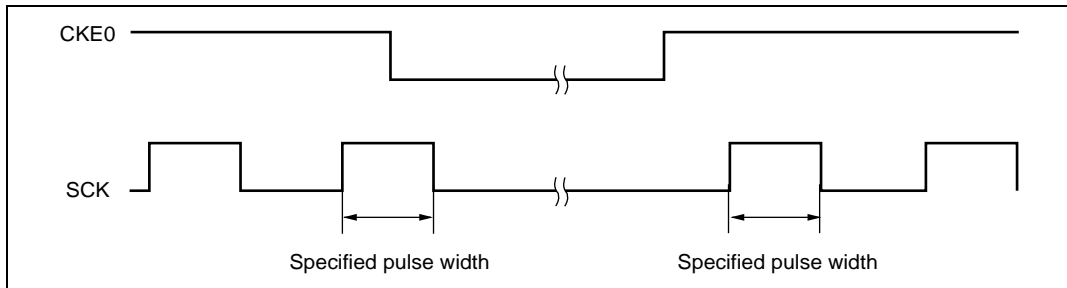

Figure 14.31 Timing for Fixing Clock Output Level

When turning on the power or switching between Smart Card interface mode and software standby mode, the following procedures should be followed in order to maintain the clock duty cycle.

Powering On: To secure clock duty cycle from power-on, the following switching procedure should be followed.

1. The initial state is port input and high impedance. Use a pull-up resistor or pull-down resistor to fix the potential.
2. Fix the SCK pin to the specified output level with the CKE1 bit in SCR.
3. Set SMR and SCMR, and switch to smart card mode operation.
4. Set the CKE0 bit in SCR to 1 to start clock output.

When changing from smart card interface mode to software standby mode:

1. Set the data register (DR) and data direction register (DDR) corresponding to the SCK pin to the value for the fixed output state in software standby mode.
2. Write 0 to the TE bit and RE bit in the serial control register (SCR) to halt transmit/receive operation. At the same time, set the CKE1 bit to the value for the fixed output state in software standby mode.
3. Write 0 to the CKE0 bit in SCR to halt the clock.
4. Wait for one serial clock period.

During this interval, clock output is fixed at the specified level, with the duty cycle preserved.

5. Make the transition to the software standby state.

When returning to smart card interface mode from software standby mode:

1. Exit the software standby state.
2. Write 1 to the CKE0 bit in SCR and output the clock. Signal generation is started with the normal duty cycle.

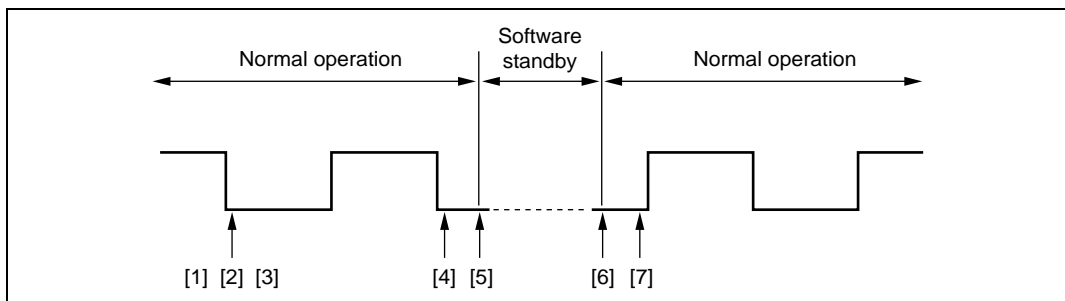

Figure 14.32 Clock Halt and Restart Procedure

14.8 Interrupt Sources

14.8.1 Interrupts in Normal Serial Communication Interface Mode

Table 14.12 shows the interrupt sources in normal serial communication interface mode. A different interrupt vector is assigned to each interrupt source, and individual interrupt sources can be enabled or disabled using the enable bits in SCR.

When the TDRE flag in SSR is set to 1, a TXI interrupt request is generated. When the TEND flag in SSR is set to 1, a TEI interrupt request is generated. A TXI interrupt can activate the DTC to perform data transfer. The TDRE flag is cleared to 0 automatically when data is transferred by the DTC.

When the RDRF flag in SSR is set to 1, an RXI interrupt request is generated. When the ORER, PER, or FER flag in SSR is set to 1, an ERI interrupt request is generated. An RXI interrupt request can activate the DTC to transfer data. The RDRF flag is cleared to 0 automatically when data is transferred by the DTC.

A TEI interrupt is requested when the TEND flag is set to 1 and the TEIE bit is set to 1. If a TEI interrupt and a TXI interrupt are requested simultaneously, the TXI interrupt has priority for acceptance. However, if the TDRE and TEND flags are cleared simultaneously by the TXI interrupt routine, the SCI cannot branch to the TEI interrupt routine later.

Table 14.12 SCI Interrupt Sources

Channel	Name	Interrupt Source	Interrupt Flag	DTC Activation
0	ERI_0	Receive Error	ORER, FER, PER	Not possible
	RXI_0	Receive Data Full	RDRF	Possible
	TXI_0	Transmit Data Empty	TDRE	Possible
	TEI_0	Transmission End	TEND	Not possible
2	ERI_2	Receive Error	ORER, FER, PER	Not possible
	RXI_2	Receive Data Full	RDRF	Possible
	TXI_2	Transmit Data Empty	TDRE	Possible
	TEI_2	Transmission End	TEND	Not possible

14.8.2 Interrupts in Smart Card Interface Mode

Table 14.13 shows the interrupt sources in Smart Card interface mode. The transmit end interrupt (TEI) request cannot be used in this mode.

Table 14.13 SCI Interrupt Sources

Channel	Name	Interrupt Source	Interrupt Flag	DTC Activation
0	ERI_0	Receive Error, error signal detection	ORER, PER, ERS	Not possible
	RXI_0	Receive Data Full	RDRF	Possible
	TXI_0	Transmit Data Empty	TEND	Possible
2	ERI_2	Receive Error, error signal detection	ORER, PER, ERS	Not possible
	RXI_2	Receive Data Full	RDRF	Possible
	TXI_2	Transmit Data Empty	TEND	Possible

In Smart Card interface mode, as in normal serial communication interface mode, transfer can be carried out using the DTC. In transmit operations, the TDRE flag is also set to 1 at the same time as the TEND flag in SSR is set, and a TXI interrupt is generated. If the TXI request is designated beforehand as a DTC activation source, the DTC will be activated by the TXI request, and transmit data will be transferred. The TDRE and TEND flags are automatically cleared to 0 when data is transferred by the DTC. In the event of an error, the SCI retransmits the same data automatically. During this period, the TEND flag remains cleared to 0 and the DTC is not activated. Therefore, the SCI and DTC will automatically transmit the specified number of bytes in the event of an error, including retransmission. However, the ERS flag is not cleared automatically when an error occurs. Hence, the RIE bit should be set to 1 beforehand so that an ERI request will be generated in the event of an error, and the ERS flag will be cleared.

When transferring using the DTC, it is essential to set and enable the DTC before carrying out SCI setting. For details of the DTC setting procedures, refer to section 8, Data Transfer Controller (DTC).

In receive operations, an RXI interrupt request is generated when the RDRF flag in SSR is set to 1. If the RXI request is designated beforehand as a DTC activation source, the DTC will be activated by the RXI request, and the receive data will be transferred. The RDRF flag is cleared to 0 automatically when data is transferred by the DTC. If an error occurs, an error flag is set but the RDRF flag is not. Consequently, the DTC is not activated, instead, an ERI interrupt request is sent to the CPU. Therefore, the error flag should be cleared.

14.9 Usage Notes

14.9.1 Module Stop Mode Setting

SCI operation can be disabled or enabled using the module stop control register. The initial setting is for SCI operation to be halted. Register access is enabled by clearing module stop mode. For details, refer to section 21, Power-Down Modes.

14.9.2 Break Detection and Processing

When framing error detection is performed, a break can be detected by reading the RxD pin value directly. In a break, the input from the RxD pin becomes all 0s, setting the FER flag, and possibly the PER flag. Note that as the SCI continues the receive operation after receiving a break, even if the FER flag is cleared to 0, it will be set to 1 again.

14.9.3 Mark State and Break Detection

When TE is 0, the TxD pin is used as an I/O port whose direction (input or output) and level are determined by DR and DDR. This can be used to set the TxD pin to mark state (high level) or send a break during serial data transmission. To maintain the communication line at mark state until TE is set to 1, set both DDR and DR to 1. As TE is cleared to 0 at this point, the TxD pin becomes an I/O port, and 1 is output from the TxD pin. To send a break during serial transmission, first set DDR to 1 and DR to 0, and then clear TE to 0. When TE is cleared to 0, the transmitter is initialized regardless of the current transmission state, the TxD pin becomes an I/O port, and 0 is output from the TxD pin.

14.9.4 Receive Error Flags and Transmit Operations (Clocked Synchronous Mode Only)

Transmission cannot be started when a receive error flag (ORER, PER, or FER) is set to 1, even if the TDRE flag is cleared to 0. Be sure to clear the receive error flags to 0 before starting transmission. Note also that receive error flags cannot be cleared to 0 even if the RE bit is cleared to 0.

Section 15 Controller Area Network (HCAN)

The HCAN is a module for controlling a controller area network (CAN) for realtime communication in vehicular and industrial equipment systems, etc. For details on CAN specification, refer to Bosch CAN Specification Version 2.0 1991, Robert Bosch GmbH.

The block diagram of the HCAN is shown in figure 15.1.

15.1 Features

- CAN version: Bosch 2.0B active compatible
 - Communication systems: NRZ (Non-Return to Zero) system (with bit-stuffing function)
 - Broadcast communication system
 - Transmission path: Bidirectional 2-wire serial communication
 - Communication speed: Max. 1 Mbps
 - Data length: 8 to 0 bytes
- Number of channels: 1
- Data buffers: 16 (one receive-only buffer and 15 buffers settable for transmission/reception)
- Data transmission: Two methods
 - Mailbox (buffer) number order (low-to-high)
 - Message priority (identifier) reverse-order (high-to-low)
- Data reception: Two methods
 - Message identifier match (transmit/receive-setting buffers)
 - Reception with message identifier masked (receive-only)
- CPU interrupts: 12
 - Error interrupt
 - Reset processing interrupt
 - Message reception interrupt
 - Message transmission interrupt
- HCAN operating modes
- Support for various modes
 - Hardware reset
 - Software reset
 - Normal status (error-active, error-passive)
 - Bus off status
 - HCAN configuration mode

- HCAN sleep mode
- HCAN halt mode
- Other features
 - DTC can be activated by message reception mailbox (HCAN mailbox 0 only)
- Module stop mode can be set

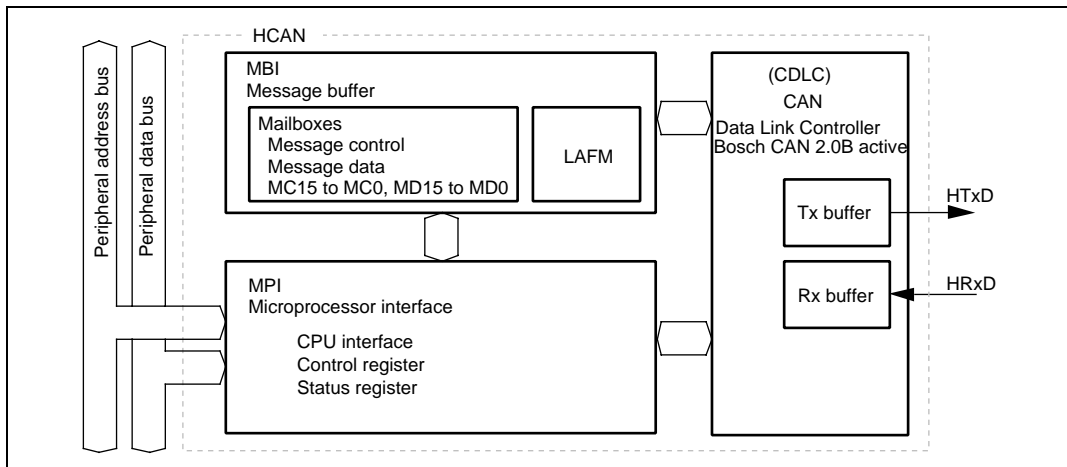

Figure 15.1 HCAN Block Diagram

- Message Buffer Interface (MBI)

The MBI, consisting of mailboxes and a local acceptance filter mask (LAFM), stores CAN transmit/receive messages (identifiers, data, etc.) Transmit messages are written by the CPU. For receive messages, the data received by the CDLC is stored automatically.
- Microprocessor Interface (MPI)

The MPI, consisting of a bus interface, control register, status register, etc., controls HCAN internal data, status, and so forth.
- CAN Data Link Controller (CDLC)

The CDLC, conforming to the Bosch CAN Ver. 2.0B active standard, performs transmission and reception of messages (data frames, remote frames, error frames, overload frames, inter-frame spacing), as well as CRC checking, bus arbitration, and other functions.

15.2 Input/Output Pins

Table 15.1 shows the HCAN's pins.

When using HCAN pins, settings must be made in the HCAN configuration mode (during initialization: MCR0 = 1 and GSR3 = 1).

Table 15.1 HCAN Pins

Name	Abbreviation	Input/Output	Function
HCAN transmit data pin	HTxD	Output	CAN bus transmission pin
HCAN receive data pin	HRxD	Input	CAN bus reception pin

A bus driver is necessary for the interface between the pins and the CAN bus. A Philips PCA82C250 compatible model is recommended.

15.3 Register Descriptions

The HCAN has the following registers.

- Master control register (MCR)
- General status register (GSR)
- Bit configuration register (BCR)
- Mailbox configuration register (MBCR)
- Transmit wait register (TXPR)
- Transmit wait cancel register (TXCR)
- Transmit acknowledge register (TXACK)
- Abort acknowledge register (ABACK)
- Receive complete register (RXPR)
- Remote request register (RFPR)
- Interrupt register (IRR)
- Mailbox interrupt mask register (MBIMR)
- Interrupt mask register (IMR)
- Receive error counter (REC)
- Transmit error counter (TEC)
- Unread message status register (UMSR)
- Local acceptance filter mask L (LAFML)

- Local acceptance filter mask H (LAFMH)
- Message control (8 bit × 8 registers × 16 sets) (MC15 to MC0)
- Message data (8 bit × 8 registers × 16 sets) (MD15 to MD0)
- HCAN Monitor Register (HCANMON)

15.3.1 Master Control Register (MCR)

MCR is an 8-bit register that controls the HCAN.

Bit	Bit Name	Initial Value	R/W	Description
7	MCR7	0	R/W	HCAN Sleep Mode Release When this bit is set to 1, the HCAN automatically exits HCAN sleep mode on detection of CAN bus operation.
6	—	0	R	Reserved This bit is always read as 0. The write value should always be 0.
5	MCR5	0	R/W	HCAN Sleep Mode When this bit is set to 1, the HCAN transits to HCAN sleep mode. When this bit is cleared to 0, HCAN sleep mode is released.
4, 3	—	All 0	R	Reserved These bits are always read as 0. The write value should always be 0.
2	MCR2	0	R/W	Message Transmission Method 0: Transmission order determined by message identifier priority 1: Transmission order determined by mailbox (buffer) number priority (TXPR1 > TXPR15)
1	MCR1	0	R/W	Halt Request When this bit is set to 1, the HCAN transits to HCAN HALT mode. When this bit is cleared to 0, HCAN HALT mode is released.

Bit	Bit Name	Initial Value	R/W	Description
0	MCR0	1	R/W	<p>Reset Request</p> <p>When this bit is set to 1, the HCAN transits to reset mode. For details, refer to 15.4.1, Hardware and Software Resets.</p> <p>[Setting condition]</p> <ul style="list-style-type: none"> 1-write (software reset) <p>[Clearing condition]</p> <ul style="list-style-type: none"> When 0 is written to this bit while the GSR3 bit in GSR is 1

15.3.2 General Status Register (GSR)

GSR is an 8-bit register that indicates the status of the CAN bus.

Bit	Bit Name	Initial Value	R/W	Description
7 to 4	—	All 0	R	<p>Reserved</p> <p>These bits are always read as 0. The write value should always be 0.</p>
3	GSR3	1	R	<p>Reset Status Bit</p> <p>Indicates whether the HCAN module is in the normal operation state or the reset state. This bit cannot be modified.</p> <p>[Setting conditions]</p> <ul style="list-style-type: none"> When entering configuration mode after the HCAN internal reset has finished Sleep mode <p>[Clearing condition]</p> <ul style="list-style-type: none"> When entering the normal operation state after the MCR0 bit in MCR is cleared to 0 (Note that there is a delay between clearing of the MCR0 bit and the GSR3 bit).

Bit	Bit Name	Initial Value	R/W	Description
2	GSR2	1	R	<p>Message Transmission Status Flag</p> <p>Flag that indicates whether the module is currently in the message transmission period. This bit cannot be modified.</p> <p>[Setting condition]</p> <ul style="list-style-type: none">• Third bit of Intermission after EOF (End of Frame) <p>[Clearing condition]</p> <ul style="list-style-type: none">• Start of message transmission (SOF)
1	GSR1	0	R	<p>Transmit/Receive Warning Flag</p> <p>This bit cannot be modified.</p> <p>[Clearing condition]</p> <ul style="list-style-type: none">• When $TEC < 96$ and $REC < 96$ or $TEC \geq 256$ (bus off state) <p>[Setting condition]</p> <ul style="list-style-type: none">• When $TEC \geq 96$ or $REC \geq 96$
0	GSR0	0	R	<p>Bus Off Flag</p> <p>This bit cannot be modified.</p> <p>[Setting condition]</p> <ul style="list-style-type: none">• When $TEC \geq 256$ (bus off state) <p>[Clearing condition]</p> <ul style="list-style-type: none">• Recovery from bus off state

15.3.3 Bit Configuration Register (BCR)

BCR is a 16-bit register that is used to set HCAN bit timing parameters and the baud rate prescaler. For details on parameters, refer to section 15.4.2, Initialization after Hardware Reset.

Bit	Bit Name	Initial Value	R/W	Description
15	BCR7	0	R/W	Re-Synchronization Jump Width (SJW)
14	BCR6	0	R/W	Set the maximum bit synchronization width. 00: 1 time quantum 01: 2 time quanta 10: 3 time quanta 11: 4 time quanta
13	BCR5	0	R/W	Baud Rate Prescaler (BRP)
12	BCR4	0	R/W	Set the length of time quanta.
11	BCR3	0	R/W	000000: $2 \times$ system clock
10	BCR2	0	R/W	000001: $4 \times$ system clock
9	BCR1	0	R/W	000010: $6 \times$ system clock
8	BCR0	0	R/W	: 111111: $128 \times$ system clock
7	BCR15	0	R/W	Bit Sample Point (BSP) Sets the point at which data is sampled. 0: Bit sampling at one point (end of time segment 1 (TSEG1)) 1: Bit sampling at three points (end of TSEG1 and preceding and following time quanta)
6	BCR14	0	R/W	Time Segment 2 (TSEG2)
5	BCR13	0	R/W	Set the TSEG2 width within a range of 2 to 8 time quanta.
4	BCR12	0	R/W	000: Setting prohibited 001: 2 time quanta 010: 3 time quanta 011: 4 time quanta 100: 5 time quanta 101: 6 time quanta 110: 7 time quanta 111: 8 time quanta

Bit	Bit Name	Initial Value	R/W	Description
3	BCR11	0	R/W	Time Segment 1 (TSEG1)
2	BCR10	0	R/W	Set the TSEG1 (PRSEG + PHSEG1) width to
1	BCR9	0	R/W	between 16 and 4 time quanta.
0	BCR8	0	R/W	0000: Setting prohibited
				0001: Setting prohibited
				0010: Setting prohibited
				0011: 4 time quanta
				0100: 5 time quanta
				0101: 6 time quanta
				0110: 7 time quanta
				0111: 8 time quanta
				1000: 9 time quanta
				1001: 10 time quanta
				1010: 11 time quanta
				1011: 12 time quanta
				1100: 13 time quanta
				1101: 14 time quanta
				1110: 15 time quanta
				1111: 16 time quanta

15.3.4 Mailbox Configuration Register (MBCR)

MBCR is a 16-bit register that is used to set the transfer direction for each mailbox.

Bit	Bit Name	Initial Value	R/W	Description
15	MBCR7	0	R/W	These bits set the transfer direction for the corresponding mailboxes 15 to 1. MBCR _n determines the transfer direction for mailbox n (n = 15 to 1).
14	MBCR6	0	R/W	
13	MBCR5	0	R/W	0: Corresponding mailbox is set for transmission 1: Corresponding mailbox is set for reception
12	MBCR4	0	R/W	
11	MBCR3	0	R/W	Bit 8 is reserved. This bit is always read as 1. The write value should always be 1.
10	MBCR2	0	R/W	
9	MBCR1	0	R/W	0: Corresponding mailbox is set for transmission 1: Corresponding mailbox is set for reception
8	—	1	R	
7	MBCR15	0	R/W	0: Corresponding mailbox is set for transmission 1: Corresponding mailbox is set for reception
6	MBCR14	0	R/W	
5	MBCR13	0	R/W	Bit 8 is reserved. This bit is always read as 1. The write value should always be 1.
4	MBCR12	0	R/W	
3	MBCR11	0	R/W	0: Corresponding mailbox is set for transmission 1: Corresponding mailbox is set for reception
2	MBCR10	0	R/W	
1	MBCR9	0	R/W	Bit 8 is reserved. This bit is always read as 1. The write value should always be 1.
0	MBCR8	0	R/W	

15.3.5 Transmit Wait Register (TXPR)

TXPR is a 16-bit register that is used to set a transmit wait after a transmit message is stored in a mailbox (buffer) (CAN bus arbitration wait).

Bit	Bit Name	Initial Value	R/W	Description
15	TXPR7	0	R/W	These bits set a transmit wait (CAN bus arbitration wait) for the corresponding mailboxes 15 to 1.
14	TXPR6	0	R/W	
13	TXPR5	0	R/W	When TXPR _n (n = 15 to 1) is set to 1, the message in mailbox n becomes the transmit wait state.
12	TXPR4	0	R/W	
11	TXPR3	0	R/W	[Clearing conditions]
10	TXPR2	0	R/W	
9	TXPR1	0	R/W	<ul style="list-style-type: none"> • Completion of message transmission • Completion of transmission cancellation
8	—	0	R	
7	TXPR15	0	R/W	Bit 8 is reserved. This bit is always read as 1. The write value should always be 1.
6	TXPR14	0	R/W	
5	TXPR13	0	R/W	
4	TXPR12	0	R/W	
3	TXPR11	0	R/W	
2	TXPR10	0	R/W	
1	TXPR9	0	R/W	
0	TXPR8	0	R/W	

15.3.6 Transmit Wait Cancel Register (TXCR)

TXCR is a 16-bit register that controls the cancellation of transmit wait messages in mailboxes (buffers).

Bit	Bit Name	Initial Value	R/W	Description
15	TXCR7	0	R/W	These bits cancel the transmit wait message in the corresponding mailboxes 15 to 1. When TXCRn (n = 15 to 1) is set to 1, the transmit wait message in mailbox n is canceled.
14	TXCR6	0	R/W	
13	TXCR5	0	R/W	[Clearing condition]
12	TXCR4	0	R/W	
11	TXCR3	0	R/W	<ul style="list-style-type: none"> Completion of TXPR clearing when transmit message is canceled normally
10	TXCR2	0	R/W	
9	TXCR1	0	R/W	Bit 8 is reserved. This bit is always read as 0. The write value should always be 0.
8	—	0	R	
7	TXCR15	0	R/W	
6	TXCR14	0	R/W	
5	TXCR13	0	R/W	
4	TXCR12	0	R/W	
3	TXCR11	0	R/W	
2	TXCR10	0	R/W	
1	TXCR9	0	R/W	
0	TXCR8	0	R/W	

15.3.7 Transmit Acknowledge Register (TXACK)

TXACK is a 16-bit register containing status flags that indicate the normal transmission of mailbox (buffer) transmit messages.

Bit	Bit Name	Initial Value	R/W	Description
15	TXACK7	0	R/(W)*	These bits are status flags that indicate error-free transmission of the transmit message in the corresponding mailboxes 15 to 1. When the message in mailbox n (n = 15 to 1) has been transmitted error-free, TXACKn is set to 1.
14	TXACK6	0	R/(W)*	
13	TXACK5	0	R/(W)*	
12	TXACK4	0	R/(W)*	
11	TXACK3	0	R/(W)*	[Setting condition]
10	TXACK2	0	R/(W)*	<ul style="list-style-type: none"> Completion of message transmission for corresponding mailbox
9	TXACK1	0	R/(W)*	
8	—	0	R	[Clearing condition]
7	TXACK15	0	R/(W)*	<ul style="list-style-type: none"> Writing 1
6	TXACK14	0	R/(W)*	
5	TXACK13	0	R/(W)*	Bit 8 is reserved. This bit is always read as 0. The write value should always be 0.
4	TXACK12	0	R/(W)*	
3	TXACK11	0	R/(W)*	
2	TXACK10	0	R/(W)*	
1	TXACK9	0	R/(W)*	
0	TXACK8	0	R/(W)*	

Note: * Only 1 can be written to clear the flag.

15.3.8 Abort Acknowledge Register (ABACK)

ABACK is a 16-bit register containing status flags that indicate the normal cancellation (aborting) of mailbox (buffer) transmit messages.

Bit	Bit Name	Initial Value	R/W	Description
15	ABACK7	0	R/(W)*	These bits are status flags that indicate error-free cancellation (abortion) of the transmit message in the corresponding mailboxes 15 to 1. When the message in mailbox n (n = 15 to 1) has been canceled error-free, ABACKn is set to 1.
14	ABACK6	0	R/(W)*	
13	ABACK5	0	R/(W)*	[Setting condition]
12	ABACK4	0	R/(W)*	
11	ABACK3	0	R/(W)*	• Completion of transmit message cancellation for corresponding mailbox
10	ABACK2	0	R/(W)*	
9	ABACK1	0	R/(W)*	[Clearing condition]
8	—	0	R	
7	ABACK15	0	R/(W)*	• Writing 1
6	ABACK14	0	R/(W)*	
5	ABACK13	0	R/(W)*	Bit 8 is reserved. This bit is always read as 0. The write value should always be 0.
4	ABACK12	0	R/(W)*	
3	ABACK11	0	R/(W)*	
2	ABACK10	0	R/(W)*	
1	ABACK9	0	R/(W)*	
0	ABACK8	0	R/(W)*	

Note: * Only 1 can be written to clear the flag.

15.3.9 Receive Complete Register (RXPR)

RXPR is a 16-bit register containing status flags that indicate the normal reception of messages in mailboxes (buffers). For reception of a remote frame, when a bit in this register is set to 1, the corresponding remote request register (RFPR) bit is also set to 1 simultaneously.

Bit	Bit Name	Initial Value	R/W	Description
15	RXPR7	0	R/(W)*	When the message in mailbox n (n = 15 to 1) has been received error-free, RXPRn is set to 1.
14	RXPR6	0	R/(W)*	
13	RXPR5	0	R/(W)*	[Setting condition]
12	RXPR4	0	R/(W)*	<ul style="list-style-type: none"> Completion of message (data frame or remote frame) reception in corresponding mailbox
11	RXPR3	0	R/(W)*	
10	RXPR2	0	R/(W)*	[Clearing condition]
9	RXPR1	0	R/(W)*	
8	RXPR0	0	R/(W)*	<ul style="list-style-type: none"> Writing 1
7	RXPR15	0	R/(W)*	
6	RXPR14	0	R/(W)*	
5	RXPR13	0	R/(W)*	
4	RXPR12	0	R/(W)*	
3	RXPR11	0	R/(W)*	
2	RXPR10	0	R/(W)*	
1	RXPR9	0	R/(W)*	
0	RXPR8	0	R/(W)*	

Note: * Only 1 can be written to clear the flag.

15.3.10 Remote Request Register (RFPR)

RFPR is a 16-bit register containing status flags that indicate normal reception of remote frames in mailboxes (buffers). When a bit in this register is set to 1, the corresponding receive complete register (RXPR) bit is also set to 1 simultaneously.

Bit	Bit Name	Initial Value	R/W	Description
15	RFPR7	0	R/(W)*	When mailbox n (n = 15 to 0) has received the remote frame error-free, RFPRn (n = 15 to 1) is set to 1.
14	RFPR6	0	R/(W)*	
13	RFPR5	0	R/(W)*	[Setting condition]
12	RFPR4	0	R/(W)*	
11	RFPR3	0	R/(W)*	<ul style="list-style-type: none"> Completion of remote frame reception in corresponding mailbox
10	RFPR2	0	R/(W)*	
9	RFPR1	0	R/(W)*	[Clearing condition]
8	RFPR0	0	R/(W)*	<ul style="list-style-type: none"> Writing 1
7	RFPR15	0	R/(W)*	
6	RFPR14	0	R/(W)*	
5	RFPR13	0	R/(W)*	
4	RFPR12	0	R/(W)*	
3	RFPR11	0	R/(W)*	
2	RFPR10	0	R/(W)*	
1	RFPR9	0	R/(W)*	
0	RFPR8	0	R/(W)*	

Note: * Only 1 can be written to clear the flag.

15.3.11 Interrupt Register (IRR)

IRR is a 16-bit interrupt status flag register.

Bit	Bit Name	Initial Value	R/W	Description
15	IRR7	0	R/(W)*	<p>Overload Frame Interrupt Flag</p> <p>Status flag indicating on overload frame has been transmitted by HCAN.</p> <p>[Setting condition]</p> <ul style="list-style-type: none">When an overload frame is transmitted in error active/passive state <p>[Clearing condition]</p> <ul style="list-style-type: none">Writing 1
14	IRR6	0	R/(W)*	<p>Bus Off Interrupt Flag</p> <p>Status flag indicating the bus off state caused by the transmit error counter.</p> <p>[Setting condition]</p> <ul style="list-style-type: none">When $TEC \geq 256$ <p>[Clearing condition]</p> <ul style="list-style-type: none">Writing 1
13	IRR5	0	R/(W)*	<p>Error Passive Interrupt Flag</p> <p>Status flag indicating the error passive state caused by the transmit/receive error counter.</p> <p>[Setting condition]</p> <ul style="list-style-type: none">When $TEC \geq 128$ or $REC \geq 128$ <p>[Clearing condition]</p> <ul style="list-style-type: none">Writing 1

Bit	Bit Name	Initial Value	R/W	Description
12	IRR4	0	R/(W)*	<p>Receive Overload Warning Interrupt Flag</p> <p>Status flag indicating the error warning state caused by the receive error counter.</p> <p>[Setting condition]</p> <ul style="list-style-type: none"> When $REC \geq 96$ <p>[Clearing condition]</p> <ul style="list-style-type: none"> Writing 1
11	IRR3	0	R/(W)*	<p>Transmit Overload Warning Interrupt Flag</p> <p>Status flag indicating the error warning state caused by the transmit error counter.</p> <p>[Setting condition]</p> <ul style="list-style-type: none"> When $TEC \geq 96$ <p>[Clearing condition]</p> <ul style="list-style-type: none"> Writing 1
10	IRR2	0	R	<p>Remote Frame Request Interrupt Flag</p> <p>Status flag indicating that a remote frame has been received in a mailbox (buffer), when MBIMR = 0.</p> <p>[Setting condition]</p> <ul style="list-style-type: none"> When remote frame reception is completed, when corresponding MBIMR = 0 <p>[Clearing condition]</p> <ul style="list-style-type: none"> Clearing of all bits in RFPR (remote request register)
9	IRR1	0	R	<p>Receive Message Interrupt Flag</p> <p>Status flag indicating that a mailbox (buffer) receive message has been received normally, when MBIMR = 0.</p> <p>[Setting condition]</p> <ul style="list-style-type: none"> When data frame or remote frame reception is completed, when corresponding MBIMR = 0 <p>[Clearing condition]</p> <ul style="list-style-type: none"> Clearing of all bits in RXPR (receive complete register)

Bit	Bit Name	Initial Value	R/W	Description
8	IRR0	1	R/(W)*	<p>Reset Interrupt Flag</p> <p>Status flag indicating that the HCAN module has been reset. This bit cannot be masked by the interrupt mask register (IMR). If this bit is not cleared to 0 after entering power-on reset or returning from software standby mode, interrupt processing will start immediately when the interrupt controller enables interrupts.</p> <p>[Setting condition]</p> <ul style="list-style-type: none"> When the reset operation has finished after entering power-on reset or software standby mode <p>[Clearing condition]</p> <ul style="list-style-type: none"> Writing 1
7 to 5	—	All 0	—	<p>Reserved</p> <p>These bits are always read as 0. The write value should always be 0.</p>
4	IRR12	0	R/(W)*	<p>Bus Operation Interrupt Flag</p> <p>Status flag indicating detection of a dominant bit due to bus operation when the HCAN module is in HCAN sleep mode.</p> <p>[Setting condition]</p> <ul style="list-style-type: none"> Bus operation (dominant bit) detection in HCAN sleep mode <p>[Clearing condition]</p> <ul style="list-style-type: none"> Writing 1
3, 2	—	All 0	—	<p>Reserved</p> <p>These bits are always read as 0. The write value should always be 0.</p>

Bit	Bit Name	Initial Value	R/W	Description
1	IRR9	0	R	<p>Unread Interrupt Flag</p> <p>Status flag indicating that a receive message has been overwritten before being read.</p> <p>[Setting condition]</p> <ul style="list-style-type: none"> When UMSR (unread message status register) is set <p>[Clearing condition]</p> <ul style="list-style-type: none"> Clearing of all bits in UMSR (unread message status register)
0	IRR8	0	R/(W)*	<p>Mailbox Empty Interrupt Flag</p> <p>Status flag indicating that the next transmit message can be stored in the mailbox.</p> <p>[Setting condition]</p> <ul style="list-style-type: none"> When TXPR (transmit wait register) is cleared by completion of transmission or completion of transmission abort <p>[Clearing condition]</p> <ul style="list-style-type: none"> Writing 1

Note: * Only 1 can be written to clear the flag.

15.3.12 Mailbox Interrupt Mask Register (MBIMR)

MBIMR is a 16-bit register that controls the enabling or disabling of individual mailbox (buffer) interrupt requests.

Bit	Bit Name	Initial Value	R/W	Description
15	MBIMR7	1	R/W	Mailbox Interrupt Mask (MBIMR _x)
14	MBIMR6	1	R/W	When MBIMR _n (n = 15 to 1) is cleared to 0, the interrupt request in mailbox n is enabled. When set to 1, the interrupt request is masked.
13	MBIMR5	1	R/W	
12	MBIMR4	1	R/W	The interrupt source in a transmit mailbox is TXPR clearing caused by transmission end or transmission cancellation. The interrupt source in a receive mailbox is RXPR setting on reception end.
11	MBIMR3	1	R/W	
10	MBIMR2	1	R/W	
9	MBIMR1	1	R/W	
8	MBIMR0	1	R/W	
7	MBIMR15	1	R/W	
6	MBIMR14	1	R/W	
5	MBIMR13	1	R/W	
4	MBIMR12	1	R/W	
3	MBIMR11	1	R/W	
2	MBIMR10	1	R/W	
1	MBIMR9	1	R/W	
0	MBIMR8	1	R/W	

15.3.13 Interrupt Mask Register (IMR)

IMR is a 16-bit register containing flags that enable or disable requests by individual interrupt sources. The reset interrupt flag cannot be masked.

Bit	Bit Name	Initial Value	R/W	Description
15	IMR7	1	R/W	Overload Frame Interrupt Mask When this bit is cleared to 0, an interrupt request by IRR7 (OVR0) is enabled. When set to 1, it is masked.
14	IMR6	1	R/W	Bus Off Interrupt Mask When this bit is cleared to 0, an interrupt request by IRR6 (ERS0) is enabled. When set to 1, it is masked.
13	IMR5	1	R/W	Error Passive Interrupt Mask When this bit is cleared to 0, an interrupt request by IRR5 (ERS0) is enabled. When set to 1, it is masked.
12	IMR4	1	R/W	Receive Overload Warning Interrupt Mask When this bit is cleared to 0, an interrupt request by IRR4 (OVR0) is enabled. When set to 1, it is masked.
11	IMR3	1	R/W	Transmit Overload Warning Interrupt Mask When this bit is cleared to 0, an interrupt request by IRR3 (OVR0) is enabled. When set to 1, it is masked.
10	IMR2	1	R/W	Remote Frame Request Interrupt Mask When this bit is cleared to 0, an interrupt request by IRR2 (OVR0) is enabled. When set to 1, it is masked.
9	IMR1	1	R/W	Receive Message Interrupt Mask When this bit is cleared to 0, an interrupt request by IRR1 (RM1) is enabled. When set to 1, it is masked.
8	—	0	R	Reserved This bit is always read as 0. The write value should always be 0.

Bit	Bit Name	Initial Value	R/W	Description
7 to 5	—	All 1	R	Reserved These bits are always read as 1. The write value should always be 0.
4	IMR12	1	R/W	Bus Operation Interrupt Mask When this bit is cleared to 0, an interrupt request by IRR12 (OVR0) is enabled. When set to 1, it is masked.
3, 2	—	All 1	R	Reserved These bits are always read as 1. The write value should always be 0.
1	IMR9	1	R/W	Unread Interrupt Mask When this bit is cleared to 0, an interrupt request by IRR9 (OVR0) is enabled. When set to 1, it is masked.
0	IMR8	1	R/W	Mailbox Empty Interrupt Mask When this bit is cleared to 0, an interrupt request by IRR8 (SLE0) is enabled. When set to 1, it is masked.

15.3.14 Receive Error Counter (REC)

The receive error counter (REC) is an 8-bit read-only register that functions as a counter indicating the number of receive message errors on the CAN bus. The count value is stipulated in the CAN protocol.

15.3.15 Transmit Error Counter (TEC)

The transmit error counter (TEC) is an 8-bit read-only register that functions as a counter indicating the number of transmit message errors on the CAN bus. The count value is stipulated in the CAN protocol.

15.3.16 Unread Message Status Register (UMSR)

UMSR is a 16-bit register containing status flags that indicate, for individual mailboxes (buffers), that a received message has been overwritten by a new receive message before being read. When overwritten by a new message, data in the unread receive message is lost.

Bit	Bit Name	Initial Value	R/W	Description
15	UMSR7	0	R/(W)*	The received message has been overwritten by a new message before being read.
14	UMSR6	0	R/(W)*	
13	UMSR5	0	R/(W)*	[Setting condition]
12	UMSR4	0	R/(W)*	<ul style="list-style-type: none"> When a new message is received before RXPR is cleared
11	UMSR3	0	R/(W)*	
10	UMSR2	0	R/(W)*	[Clearing condition]
9	UMSR1	0	R/(W)*	<ul style="list-style-type: none"> Writing 1
8	UMSR0	0	R/(W)*	
7	UMSR15	0	R/(W)*	
6	UMSR14	0	R/(W)*	
5	UMSR13	0	R/(W)*	
4	UMSR12	0	R/(W)*	
3	UMSR11	0	R/(W)*	
2	UMSR10	0	R/(W)*	
1	UMSR9	0	R/(W)*	
0	UMSR8	0	R/(W)*	

Note: * Only 1 can be written to clear the flag.

15.3.17 Local Acceptance Filter Masks (LAFML, LAFMH)

LAFML and LAFMH are 16-bit registers that individually set the identifier bits of the message to be stored in mailbox 0 as Don't Care. For details, refer to section 15.4.4, Message Reception. The relationship between the identifier bits and mask bits are shown in the following.

- LAFML

Bit	Bit Name	Initial Value	R/W	Description
15	LAFML7	0	R/W	When this bit is set to 1, ID-7 of the receive message identifier is not compared.
14	LAFML6	0	R/W	When this bit is set to 1, ID-6 of the receive message identifier is not compared.
13	LAFML5	0	R/W	When this bit is set to 1, ID-5 of the receive message identifier is not compared.
12	LAFML4	0	R/W	When this bit is set to 1, ID-4 of the receive message identifier is not compared.
11	LAFML3	0	R/W	When this bit is set to 1, ID-3 of the receive message identifier is not compared.
10	LAFML2	0	R/W	When this bit is set to 1, ID-2 of the receive message identifier is not compared.
9	LAFML1	0	R/W	When this bit is set to 1, ID-1 of the receive message identifier is not compared.
8	LAFML0	0	R/W	When this bit is set to 1, ID-0 of the receive message identifier is not compared.
7	LAFML15	0	R/W	When this bit is set to 1, ID-15 of the receive message identifier is not compared.
6	LAFML14	0	R/W	When this bit is set to 1, ID-14 of the receive message identifier is not compared.
5	LAFML13	0	R/W	When this bit is set to 1, ID-13 of the receive message identifier is not compared.
4	LAFML12	0	R/W	When this bit is set to 1, ID-12 of the receive message identifier is not compared.
3	LAFML11	0	R/W	When this bit is set to 1, ID-11 of the receive message identifier is not compared.
2	LAFML10	0	R/W	When this bit is set to 1, ID-10 of the receive message identifier is not compared.
1	LAFML9	0	R/W	When this bit is set to 1, ID-9 of the receive message identifier is not compared.
0	LAFML8	0	R/W	When this bit is set to 1, ID-8 of the receive message identifier is not compared.

- LAFMH

Bit	Bit Name	Initial Value	R/W	Description
15	LAFMH7	0	R/W	When this bit is set to 1, ID-20 of the receive message identifier is not compared.
14	LAFMH6	0	R/W	When this bit is set to 1, ID-19 of the receive message identifier is not compared.
13	LAFMH5	0	R/W	When this bit is set to 1, ID-18 of the receive message identifier is not compared.
12 to 10	—	All 0	R	Reserved These bits are always read as 0. The write value should always be 0.
9	LAFMH1	0	R/W	When this bit is set to 1, ID-17 of the receive message identifier is not compared.
8	LAFMH0	0	R/W	When this bit is set to 1, ID-16 of the receive message identifier is not compared.
7	LAFMH15	0	R/W	When this bit is set to 1, ID-28 of the receive message identifier is not compared.
6	LAFMH14	0	R/W	When this bit is set to 1, ID-27 of the receive message identifier is not compared.
5	LAFMH13	0	R/W	When this bit is set to 1, ID-26 of the receive message identifier is not compared.
4	LAFMH12	0	R/W	When this bit is set to 1, ID-25 of the receive message identifier is not compared.
3	LAFMH11	0	R/W	When this bit is set to 1, ID-24 of the receive message identifier is not compared.
2	LAFMH10	0	R/W	When this bit is set to 1, ID-23 of the receive message identifier is not compared.
1	LAFMH9	0	R/W	When this bit is set to 1, ID-22 of the receive message identifier is not compared.
0	LAFMH8	0	R/W	When this bit is set to 1, ID-21 of the receive message identifier is not compared.

15.3.18 Message Control (MC15 to MC0)

The message control register sets consist of eight 8-bit registers for one mailbox. The HCAN has 16 sets of these registers. Because message control registers are in RAM, their initial values after power-on are undefined. Be sure to initialize them by writing 1 or 0. Figure 15.2 shows the register names for each mailbox.

Mail box 0	MC0[1]	MC0[2]	MC0[3]	MC0[4]	MC0[5]	MC0[6]	MC0[7]	MC0[8]
Mail box 1	MC1[1]	MC1[2]	MC1[3]	MC1[4]	MC1[5]	MC1[6]	MC1[7]	MC1[8]
Mail box 2	MC2[1]	MC2[2]	MC2[3]	MC2[4]	MC2[5]	MC2[6]	MC2[7]	MC2[8]
Mail box 3	MC3[1]	MC3[2]	MC3[3]	MC3[4]	MC3[5]	MC3[6]	MC3[7]	MC3[8]
Mail box 15	MC15[1]	MC15[2]	MC15[3]	MC15[4]	MC15[5]	MC15[6]	MC15[7]	MC15[8]

Figure 15.2 Message Control Register Configuration

The setting of message control registers are shown in the following. Figures 15.3 and 15.4 show the correspondence between the identifiers and register bit names.

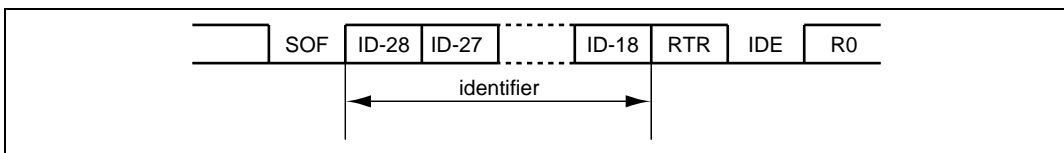

Figure 15.3 Standard Format

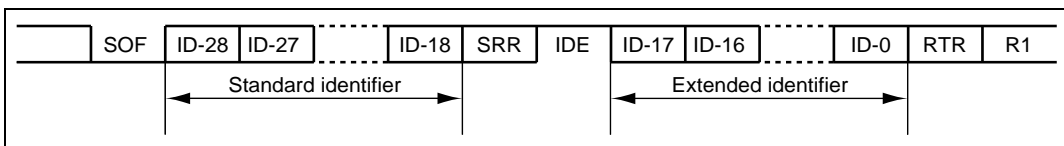

Figure 15.4 Extended Format

Register Name	Bit	Bit Name	R/W	Description
MCx[1]	7 to 4	—	R/W	The initial value of these bits is undefined. They must be initialized by writing 0 or 1.
	3 to 0	DLC3 to DLC0	R/W	Data Length Code Set the data length of a data frame or the data length requested in a remote frame within the range of 0 to 8 bits. 0000: 0 bytes 0001: 1 byte 0010: 2 bytes 0011: 3 bytes 0100: 4 bytes 0101: 5 bytes 0110: 6 bytes 0111: 7 bytes 1***: 8 bytes
MCx[2]	7 to 0	—	R/W	The initial value of these bits is undefined; they must be initialized by writing 0 or 1.
MCx[3]	7 to 0	—	R/W	
MCx[4]	7 to 0	—	R/W	
MCx[5]	7 to 5	ID-20 to ID-18	R/W	Sets ID-20 to ID-18 in the identifier.
	4	RTR	R/W	Remote Transmission Request Used to distinguish between data frames and remote frames. 0: Data frame 1: Remote frame
	3	IDE	R/W	Identifier Extension Used to distinguish between the standard format and extended format of data frames and remote frames. 0: Standard format 1: Extended format
	2	—	R/W	The initial value of this bit is undefined. It must be initialized by writing 0 or 1.
	1 to 0	ID-17 to ID-16	R/W	Sets ID-17 and ID-16 in the identifier.
MCx[6]	7 to 0	ID-28 to ID-21	R/W	Sets ID-28 to ID-21 in the identifier.
MCx[7]	7 to 0	ID-7 to ID-0	R/W	Sets ID-7 to ID-0 in the identifier.
MCx[8]	7 to 0	ID-15 to ID-8	R/W	Sets ID-15 to ID-8 in the identifier.

Note: x: Mailbox number

15.3.19 Message Data (MD15 to MD0)

The message data register sets consist of eight 8-bit registers for one mailbox. The HCAN has 16 sets of these registers. Because message data registers are in RAM, their initial values after power-on are undefined. Be sure to initialize them by writing 1 or 0. Figure 15.5 shows the register names for each mailbox.

Mail box 0	MD0[1]	MD0[2]	MD0[3]	MD0[4]	MD0[5]	MD0[6]	MD0[7]	MD0[8]
Mail box 1	MD1[1]	MD1[2]	MD1[3]	MD1[4]	MD1[5]	MD1[6]	MD1[7]	MD1[8]
Mail box 2	MD2[1]	MD2[2]	MD2[3]	MD2[4]	MD2[5]	MD2[6]	MD2[7]	MD2[8]
Mail box 3	MD3[1]	MD3[2]	MD3[3]	MD3[4]	MD3[5]	MD3[6]	MD3[7]	MD3[8]
Mail box 15	MD15[1]	MD15[2]	MD15[3]	MD15[4]	MD15[5]	MD15[6]	MD15[7]	MD15[8]

Figure 15.5 Message Data Configuration

15.3.20 HCAN Monitor Register (HCANMON)

HCANMON is an 8-bit register that enables/disables an HCAN receive interrupt, controls transmission stop of the HTxD pin, and reflects the states of the HCAN pins.

Bit	Bit Name	Initial Value	R/W	Description
7	RxDIE	0	R/W	<p>HRxD Interrupt Enable</p> <p>Selects whether an $\overline{\text{IRQ2}}$ interrupt is caused by PF0 or HRxD pin.</p> <p>0: An $\overline{\text{IRQ2}}$ interrupt is caused by pin PF0</p> <p>1: An $\overline{\text{IRQ2}}$ interrupt is caused by the HRxD pin</p>
6	TxSTP	0	R/W	<p>HTxD Transmission Stop</p> <p>Controls transmission stop of the HTxD pin.</p> <p>0: Enables transmission from the HTxD pin</p> <p>1: Fixes an output level of the HTxD pin at 1 and transmission is stopped</p>
5 to 2	—	Undefined	—	<p>Reserved</p> <p>These bits are always read as undefined values and cannot be modified.</p>
1	TxD	Undefined	R	<p>Transmission pin</p> <p>The state of the HTxD pin is read.</p> <p>This bit cannot be modified.</p>
0	RxD	Undefined	R	<p>Reception pin</p> <p>The state of the HRxD pin is read.</p> <p>This bit cannot be modified.</p>

15.4 Operation

15.4.1 Hardware and Software Resets

The HCAN can be reset by a hardware reset or software reset.

- **Hardware Reset**

At power-on reset, or in hardware or software standby mode, the HCAN is initialized by automatically setting the MCR reset request bit (MCR0) in MCR and the reset state bit (GSR3) in GSR. At the same time, all internal registers, except for message control and message data registers, are initialized by a hardware reset.

- **Software Reset**

The HCAN can be reset by setting the MCR reset request bit (MCR0) in MCR via software. In a software reset, the error counters (TEC and REC) are initialized, however other registers are not. If the MCR0 bit is set while the CAN controller is performing a communication operation (transmission or reception), the initialization state is not entered until message transfer has been completed. The reset status bit (GSR3) in GSR is set on completion of initialization.

15.4.2 Initialization after Hardware Reset

After a hardware reset, the following initialization processing should be carried out:

1. Clearing of IRR0 bit in the interrupt register (IRR)
2. Bit rate setting
3. Mailbox transmit/receive settings
4. Mailbox (RAM) initialization
5. Message transmission method setting

These initial settings must be made while the HCAN is in bit configuration mode. Configuration mode is a state in which the GSR3 bit in GSR is set to 1 by a reset. Configuration mode is exited by clearing the MCR0 bit in MCR to 0; when the MCR0 bit is cleared to 0, the HCAN automatically clears the GSR3 bit in GSR. There is a delay between clearing the MCR0 bit and clearing the GSR3 bit because the HCAN needs time to be internally reset. After the HCAN exits configuration mode, the power-up sequence begins, and communication with the CAN bus is possible as soon as 11 consecutive recessive bits have been detected.

IRR0 Clearing: The reset interrupt flag (IRR0) is always set after a power-on reset or recovery from software standby mode. Since an HCAN interrupt is initiated immediately when interrupts are enabled, IRR0 should be cleared.

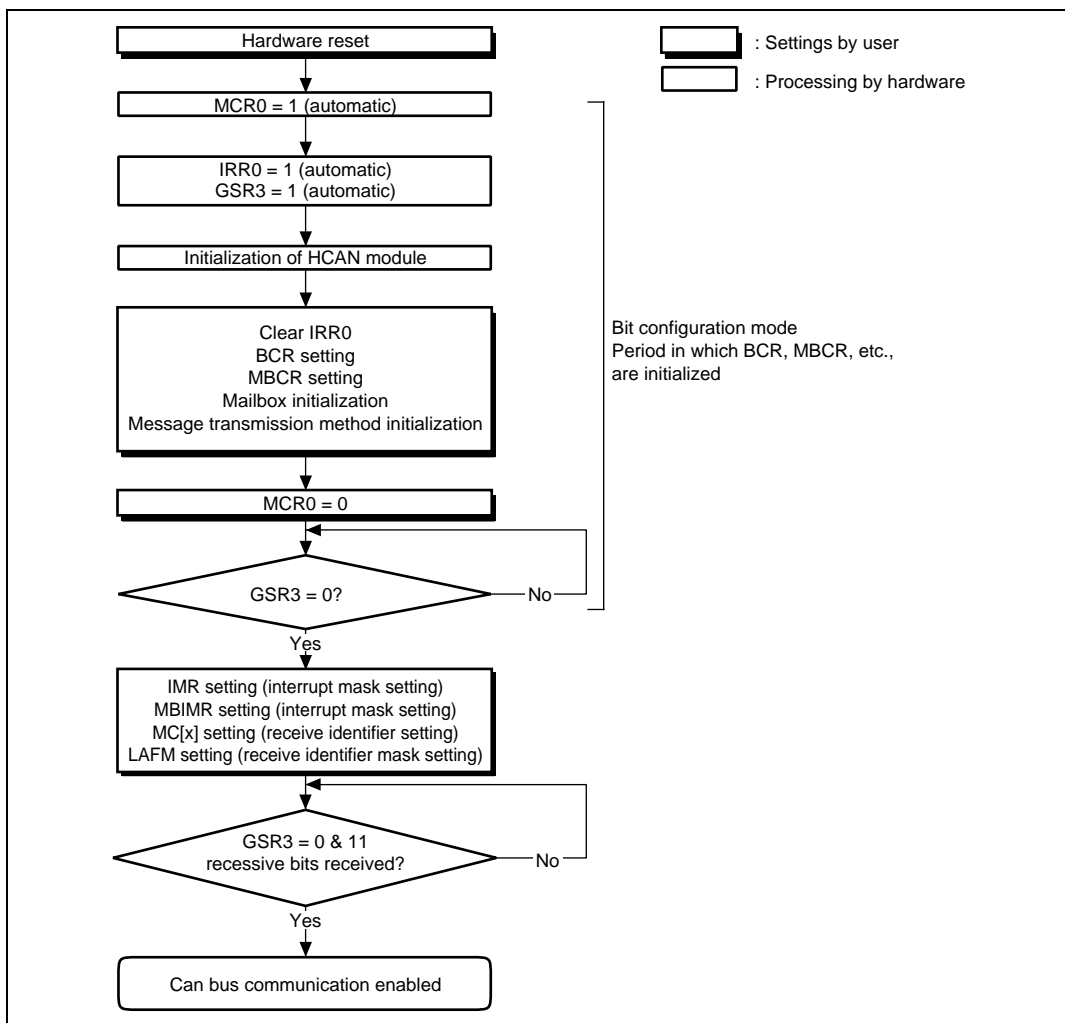

Figure 15.6 Hardware Reset Flowchart

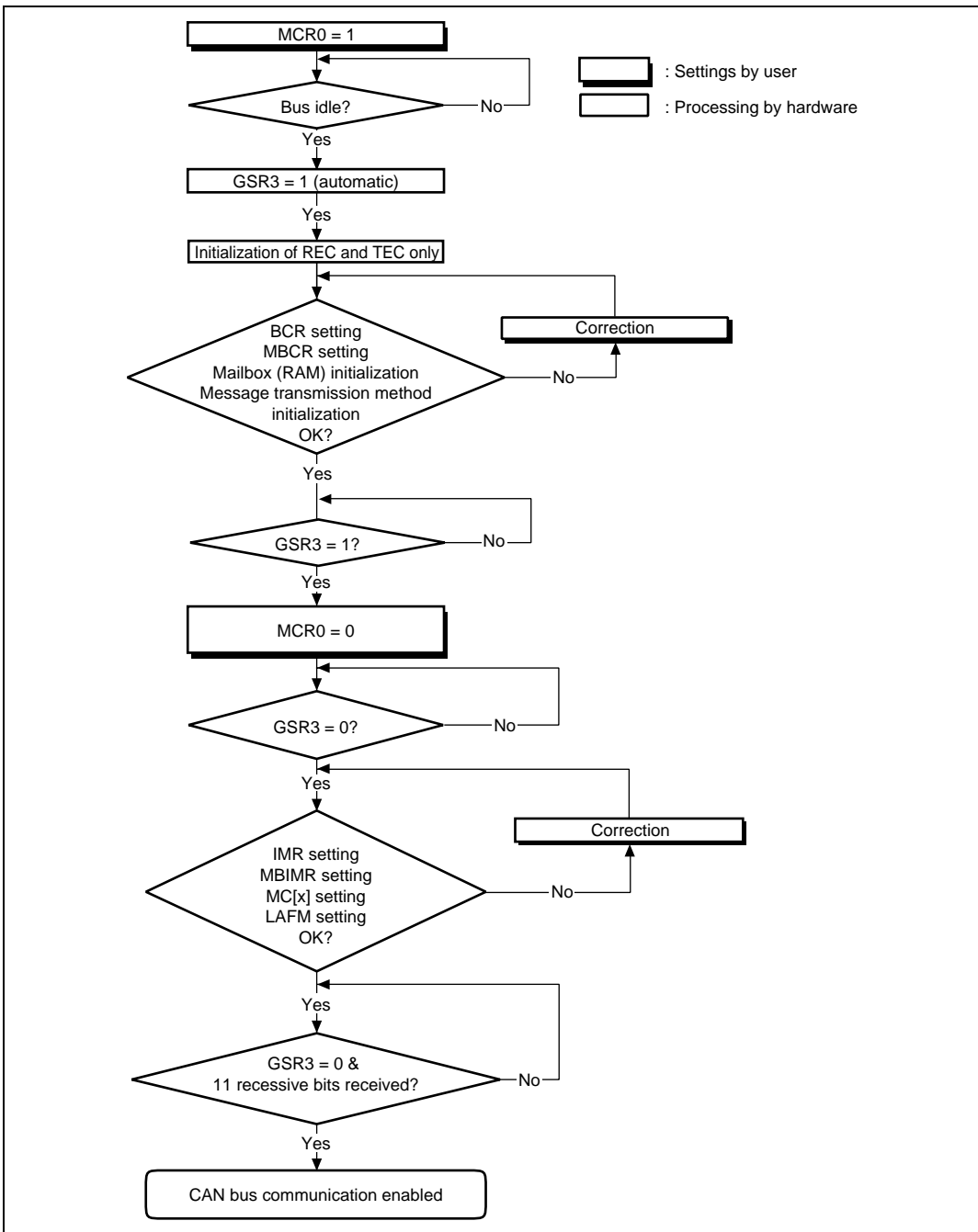

Figure 15.7 Software Reset Flowchart

Bit Rate and Bit Timing Settings: The bit rate and bit timing settings are made in the bit configuration register (BCR). Settings should be made such that all CAN controllers connected to the CAN bus have the same baud rate and bit width. The 1-bit time consists of the total of the settable time quanta (tq).

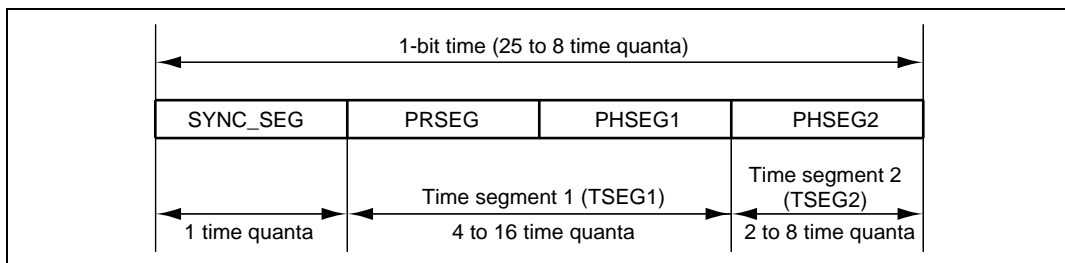

Figure 15.8 Detailed Description of One Bit

SYNC_SEG is a segment for establishing the synchronization of nodes on the CAN bus. Normal bit edge transitions occur in this segment. PRSEG is a segment for compensating for the physical delay between networks. PHSEG1 is a buffer segment for correcting phase drift (positive). This segment is extended when synchronization (resynchronization) is established. PHSEG2 is a buffer segment for correcting phase drift (negative). This segment is shortened when synchronization (resynchronization) is established. Limits on the settable value (TSEG1, TSEG2, BRP, BSP, and SJW) are shown in table 15.2.

Table 15.2 Limits for the Settable Value

Name	Abbreviation	Min. Value	Max. Value
Time segment 1	TSEG1	B'0011 ^{*2}	B'1111
Time segment 2	TSEG2	B'001 ^{*3}	B'111
Baud rate prescaler	BRP	B'000000	B'1111111
Bit sample point	BSP	B'0	B'1
Re-synchronization jump width	SJW ^{*1}	B'00	B'11

Notes: 1. SJW is stipulated in the CAN specifications:

$$3 \geq \text{SJW} \geq 0$$

2. The minimum value of TSEG2 is stipulated in the CAN specifications:
 $\text{TSEG2} \geq \text{SJW}$

3. The minimum value of TSEG1 is stipulated in the CAN specifications:
 $\text{TSEG1} > \text{TSEG2}$

Time quanta (tq) is an integer multiple of the number of system clocks, and is determined by the baud rate prescaler (BRP) as follows. f_{CLK} is the system clock frequency.

$$tq = 2 \times (\text{BPR setting} + 1) / f_{CLK}$$

The following formula is used to calculate the 1-bit time and bit rate.

$$\text{1-bit time} = tq \times (3 + \text{TSEG1} + \text{TSEG2})$$

$$\begin{aligned} \text{Bit rate} &= 1 / \text{Bit time} \\ &= f_{CLK} / \{2 \times (\text{BPR setting} + 1) \times (3 + \text{TSEG1} + \text{TSEG2})\} \end{aligned}$$

Note: $f_{CLK} = \phi$ (system clock)

A BCR value is used for BRP, TSEG1, and TSEG2.

Example: With a system clock of 24 MHz, a BRP setting of B'000000, a TSEG1 setting of B'0101, and a TSEG2 setting of B'100:

$$\text{Bit rate} = 24 / \{2 \times (0 + 1) \times (3 + 5 + 4)\} = 1 \text{ Mbps}$$

Table 15.3 Setting Range for TSEG1 and TSEG2 in BCR

		TSEG2 (BCR14 to BCR12)						
		001	010	011	100	101	110	111
TSEG1 (BCR11 to BCR8)	0011	No	Yes	No	No	No	No	No
	0100	Yes*	Yes	Yes	No	No	No	No
	0101	Yes*	Yes	Yes	Yes	No	No	No
	0110	Yes*	Yes	Yes	Yes	Yes	No	No
	0111	Yes*	Yes	Yes	Yes	Yes	Yes	No
	1000	Yes*	Yes	Yes	Yes	Yes	Yes	Yes
	1001	Yes*	Yes	Yes	Yes	Yes	Yes	Yes
	1010	Yes*	Yes	Yes	Yes	Yes	Yes	Yes
	1011	Yes*	Yes	Yes	Yes	Yes	Yes	Yes
	1100	Yes*	Yes	Yes	Yes	Yes	Yes	Yes
	1101	Yes*	Yes	Yes	Yes	Yes	Yes	Yes
	1110	Yes*	Yes	Yes	Yes	Yes	Yes	Yes
1111	Yes*	Yes	Yes	Yes	Yes	Yes	Yes	

Note: The time quantum values for TSEG1 and TSEG2 are determined by TSEG value + 1.

* Settable when bits BRP is not B'000000.

Mailbox Transmit/Receive Settings: The HCAN has 16 mailboxes. Mailbox 0 is receive-only, while mailboxes 15 to 1 can be set for transmission or reception. The initial status of mailboxes 15 to 1 is for transmission. Mailbox transmit/receive settings are not initialized by a software reset.

Clearing a bit to 0 in the mailbox configuration register (MBCR) designates the corresponding mailbox for transmission use, whereas a setting of 1 in MBCR designates the corresponding mailbox for reception use. When setting mailboxes for reception, in order to improve message reception efficiency, high-priority messages should be set in low-to-high mailbox order.

Mailbox (Message Control/Data) Initial Settings: Message control/data are held in RAM, and so their initial values are undefined after power is supplied. Initial values must therefore be set in all the mailboxes (by writing 0s or 1s).

Setting the Message Transmission Method: The following two kinds of message transmission methods are available.

- Transmission order determined by message identifier priority
- Transmission order determined by mailbox number priority

Either of the message transmission methods can be selected with the message transmission method bit (MCR2) in the master control register (MCR): When messages are set to be transmitted according to the message identifier priority, if several messages are designated as waiting for transmission (TXPR = 1), the message with the highest priority in the message identifier is stored in the transmit buffer. CAN bus arbitration is then carried out for the message stored in the transmit buffer, and the message is transmitted when the transmission right is acquired. When the TXPR bit is set, the highest-priority message is found and stored in the transmit buffer.

When messages are set to be transmitted according to the mailbox number priority, if several messages are designated as waiting for transmission (TXPR = 1), messages are stored in the transmit buffer in low-to-high mailbox order. CAN bus arbitration is then carried out for the message stored in the transmit buffer, and the message is transmitted when the transmission right is acquired.

15.4.3 Message Transmission

Messages are transmitted using mailboxes 15 to 1. The transmission procedure after initial settings is described below, and a transmission flowchart is shown in figure 15.9.

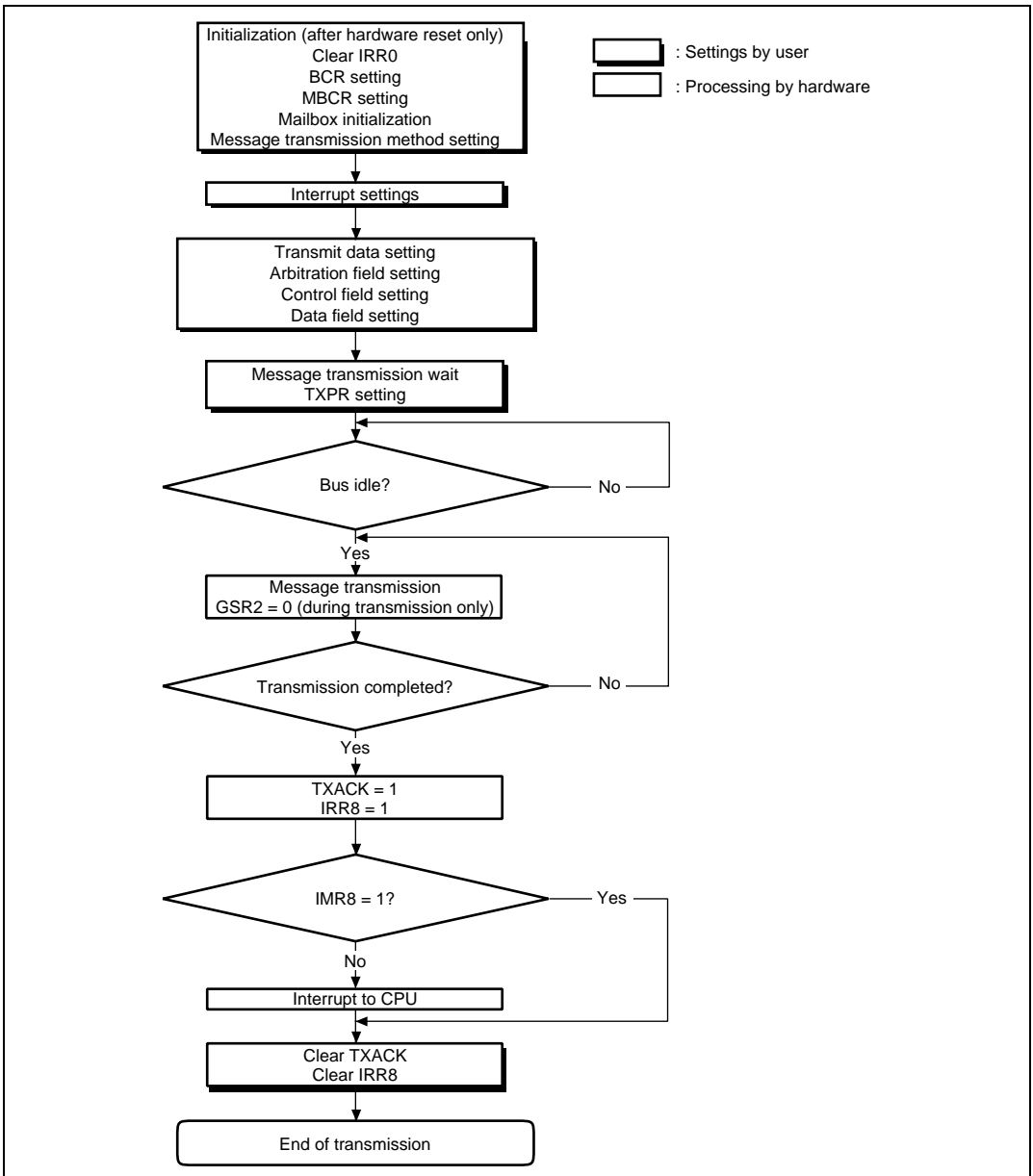

Figure 15.9 Transmission Flowchart

CPU Interrupt Source Settings: The CPU interrupt source is set by the interrupt mask register (IMR) and mailbox interrupt mask register (MBIMR). Transmission acknowledge and

transmission abort acknowledge interrupts can be generated for individual mailboxes in the mailbox interrupt mask register (MBIMR).

Arbitration Field Setting: The arbitration field is set by the message control registers MCx[8] to MCx[5] in a transmit mailbox. For a standard format, an 11-bit identifier (ID-28 to ID-18) and the RTR bit are set, and the IDE bit is cleared to 0. For an extended format, a 29-bit identifier (ID-28 to ID-0) and the RTR bit are set, and the IDE bit is set to 1.

Control Field Setting: In the control field, the byte length of the data to be transmitted is set within the range of zero to eight bytes. The register to be set is the message control register MCx[1] in a transmit mailbox.

Data Field Setting: In the data field, the data to be transmitted is set within the range zero to eight. The registers to be set are the message data registers MDx[8] to MDx[1]. The byte length of the data to be transmitted is determined by the data length code in the control field. Even if data exceeding the value set in the control field is set in the data field, up to the byte length set in the control field will actually be transmitted.

Message Transmission: If the corresponding mailbox transmit wait bit (TXPR15 to TXPR1) in the transmit wait register (TXPR) is set to 1 after message control and message data registers have been set, the message enters transmit wait state. If the message is transmitted error-free, the corresponding acknowledge bit (TXACK15 to TXACK1) in the transmit acknowledge register (TXACK) is set to 1, and the corresponding transmit wait bit (TXPR15 to TXPR1) in the transmit wait register (TXPR) is automatically cleared to 0. Also, if the corresponding bit (MBIMR1 to MBIMR15) in the mailbox interrupt mask register (MBIMR) and the mailbox empty interrupt bit (IRR8) in the interrupt mask register (IMR) are both simultaneously set to enable interrupts, interrupts may be sent to the CPU.

If transmission of a transmit message is aborted in the following cases, the message is retransmitted automatically:

- CAN bus arbitration failure (failure to acquire the bus)
- Error during transmission (bit error, stuff error, CRC error, frame error, or ACK error)

Message Transmission Cancellation: Transmission cancellation can be specified for a message stored in a mailbox as a transmit wait message. A transmit wait message is canceled by setting the bit for the corresponding mailbox (TXCR15 to TXCR1) to 1 in the transmit cancel register (TXCR). Clearing the transmit wait register (TXPR) does not cancel transmission. When cancellation is executed, the transmit wait register (TXPR) is automatically reset, and the corresponding bit is set to 1 in the abort acknowledge register (ABACK), and then an interrupt to the CPU can be requested. Also, if the corresponding bit (MBIMR15 to MBIMR1) in the mailbox

interrupt mask register (MBIMR) and the mailbox empty interrupt bit (IRR8) in the interrupt mask register (IMR) are both simultaneously set to enable interrupts, interrupts may be sent to the CPU.

However, a transmit wait message cannot be canceled at the following times:

- During internal arbitration or CAN bus arbitration
- During data frame or remote frame transmission

Figure 15.10 shows a flowchart for transmit message cancellation.

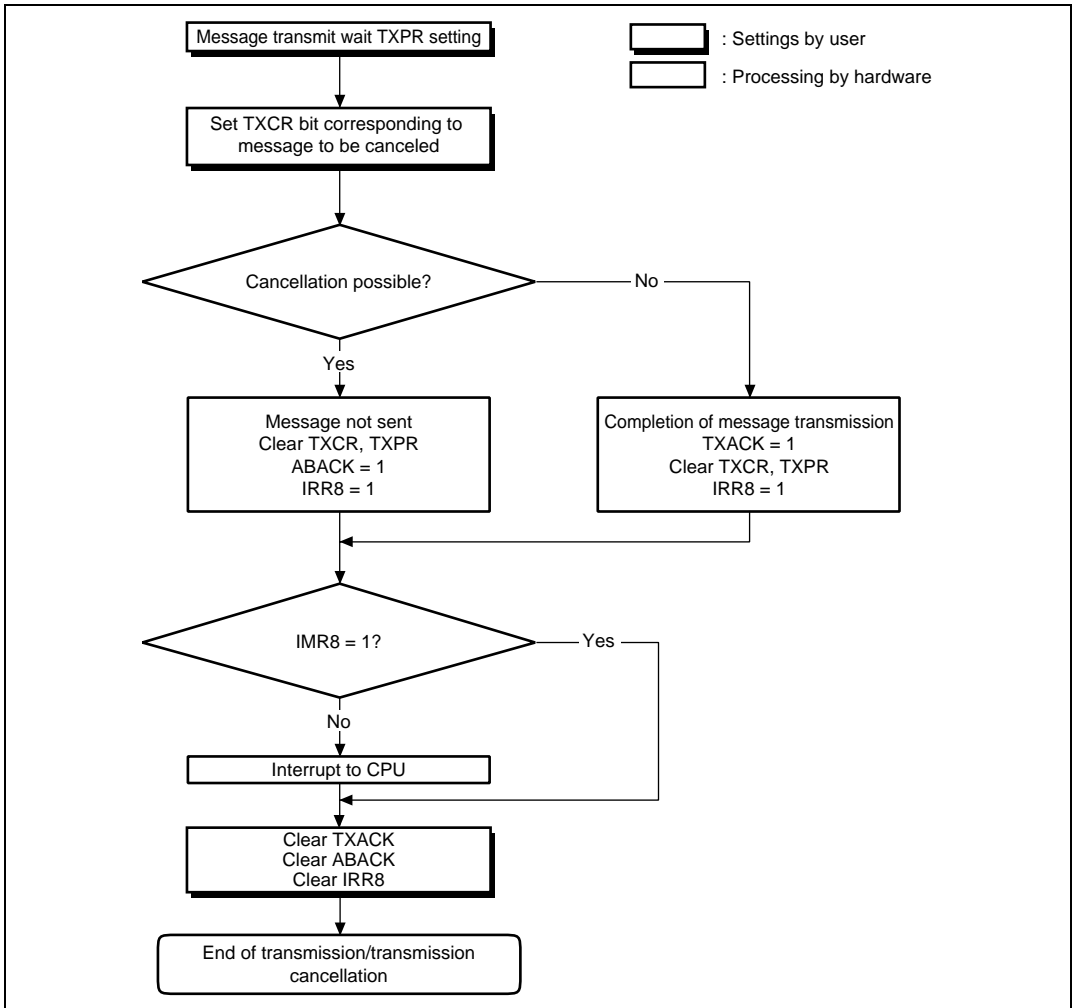

Figure 15.10 Transmit Message Cancellation Flowchart

15.4.4 Message Reception

The reception procedure after initial settings is described below. A reception flowchart is shown in Figure 15.11.

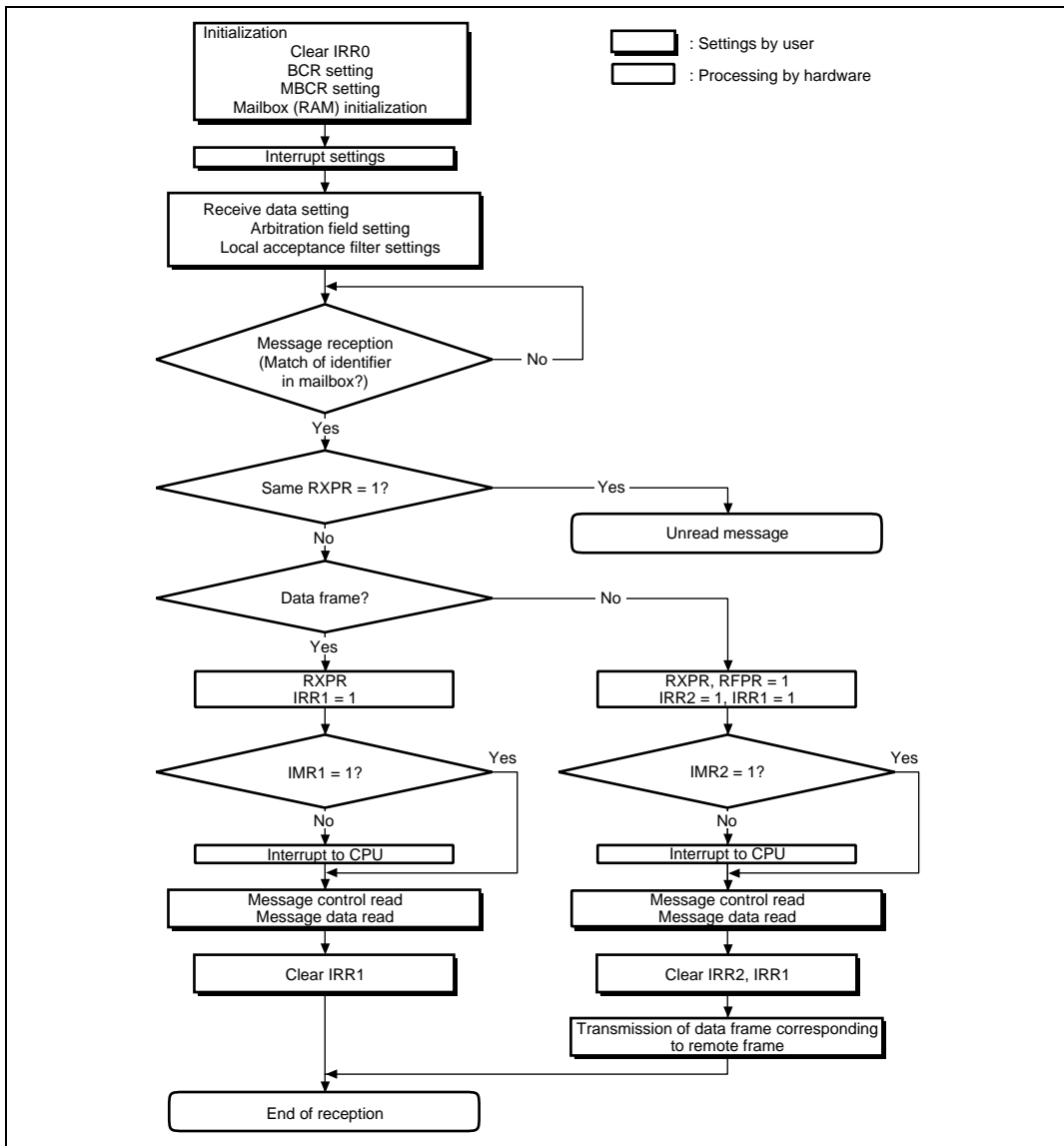

Figure 15.11 Reception Flowchart

CPU Interrupt Source Settings: CPU interrupt source settings are made in the interrupt mask register (IMR) and mailbox interrupt register (MBIMR). The message to be received is also specified. Data frame and remote frame receive wait interrupt requests can be generated for individual mailboxes in the MBIMR.

Arbitration Field Setting: To receive a message, the message identifier must be set in advance in the message control registers (MCx[8] to MCx[1]) for the receiving mailbox. When a message is received, all the bits in the receive message identifier are compared with those in each message control register identifier, and if a complete match is found, the message is stored in the matching mailbox. Mailbox 0 has a local acceptance filter mask (LAFM) that allows Don't Care settings. The LAFM setting can be made only for mailbox 0. By setting the Don't Care for all the bits in the receive message identifier, messages of multiple identifiers can be received.

Examples:

- When the identifier of mailbox 1 is 010_1010_1010 (standard format), only one kind of message identifier can be received by mailbox 1:
Identifier 1: 010_1010_1010
- When the identifier of mailbox 0 is 010_1010_1010 (standard format) and the LAFM setting is 000_0000_0011 (0: Care, 1: Don't Care), a total of four kinds of message identifiers can be received by mailbox 0:
Identifier 1: 010_1010_1000
Identifier 2: 010_1010_1001
Identifier 3: 010_1010_1010
Identifier 4: 010_1010_1011

Message Reception: When a message is received, a CRC check is performed automatically. If the result of the CRC check is normal, ACK is transmitted in the ACK field irrespective of whether the message can be received or not.

- Data frame reception
If the received message is confirmed to be error-free by the CRC check, the identifier in the mailbox (and also LAFM in the case of mailbox 0 only) and the identifier of the receive message are compared. If a complete match is found, the message is stored in the matching mailbox. The message identifier comparison is carried out on each mailbox in turn, starting with mailbox 0 and ending with mailbox 15. If a complete match is found, the comparison ends at that point, the message is stored in the matching mailbox, and the corresponding receive complete bit (RXPR15 to RXPR0) in the receive complete register (RXPR) is set. However, if the identifier matches that of mailbox 0 LAFM, the mailbox comparison sequence does not end at that point, but continues from mailbox 1. Therefore, the message for mailbox 0

can also be received by another mailbox. Note that the same message cannot be stored in two or more mailbox of the mailboxes 15 to 1. On receiving a message, a CPU interrupt request may be generated according to the settings of the mailbox interrupt mask register (MBIMR) and interrupt mask register (IMR).

- Remote frame reception

A mailbox can store two kinds of messages: data frames and remote frames. A remote frame differs from a data frame in the value of the remote transmission request bit (RTR) in the message control register and its 0-byte data field. The data length to be returned in a data frame must be stored in the data length code (DLC) in the message control.

When a remote frame (RTR = recessive) is received, the corresponding bit in the remote request wait register (RFPR) is set. Interrupts can be sent to the CPU according to the settings of the corresponding bit (MBIMR15 to MBIMR0) in the mailbox interrupt mask register (MBIMR) and the remote frame request interrupt mask (IRR2) in the interrupt mask register (IMR).

Unread Message Overwrite: If the receive message identifier matches the mailbox identifier, the receive message is stored in the mailbox regardless of whether the mailbox contains an unread message or not. If a message overwrite occurs, the corresponding bit (UMSR15 to UMSR0) in the unread message register (UMSR) is set. In overwriting an unread message, the unread message register (UMSR) is set when a new message is received before the corresponding bit in the receive complete register (RXPR) has been cleared. If the unread interrupt flag (IRR9) in the interrupt mask register (IMR) is set to enable interrupts at this time, an interrupt can be sent to the CPU. Figure 15.12 shows a flowchart for unread message overwriting.

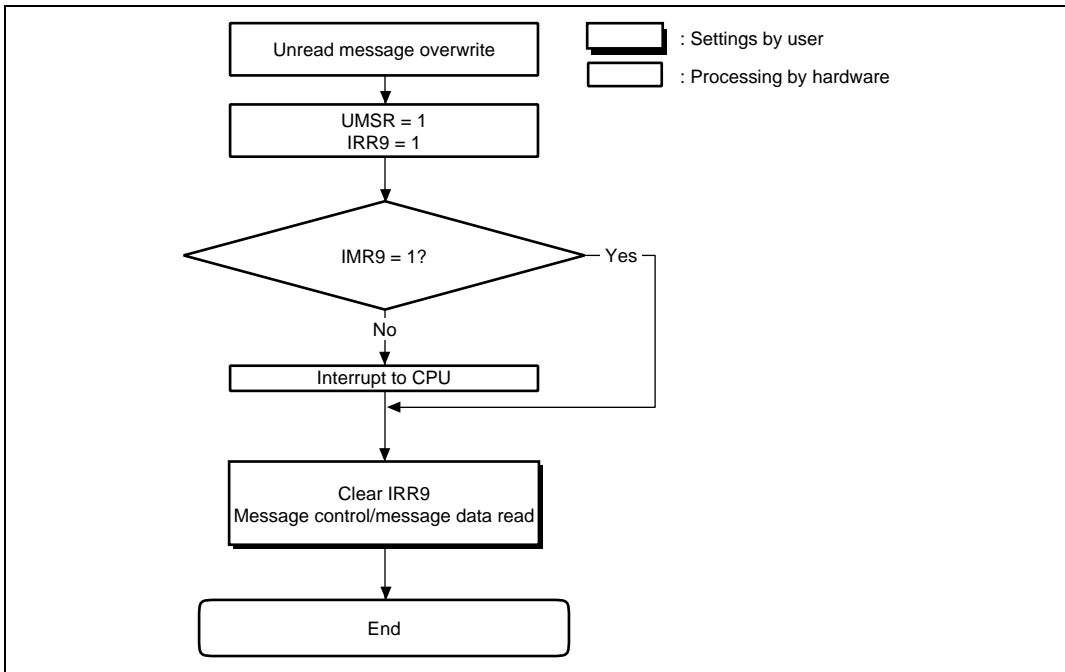

Figure 15.12 Unread Message Overwrite Flowchart

15.4.5 HCAN Sleep Mode

The HCAN is provided with an HCAN sleep mode that places the HCAN module in the sleep state in order to reduce current consumption. Figure 15.13 shows a flowchart of the HCAN sleep mode.

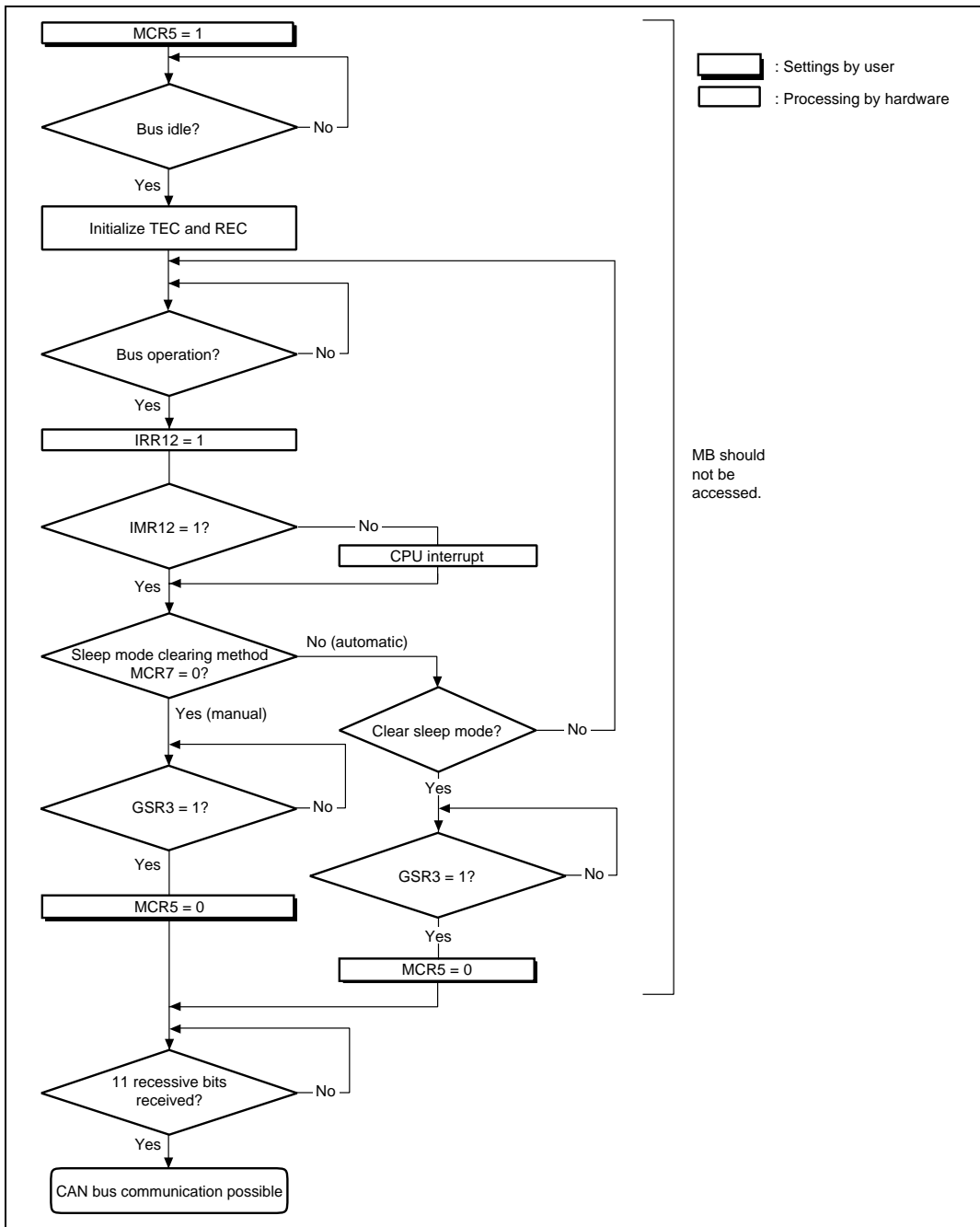

Figure 15.13 HCAN Sleep Mode Flowchart

HCAN sleep mode is entered by setting the HCAN sleep mode bit (MCR5) to 1 in the master control register (MCR). If the CAN bus is operating, the transition to HCAN sleep mode is delayed until the bus becomes idle.

Either of the following methods of clearing HCAN sleep mode can be selected:

- Clearing by software
- Clearing by CAN bus operation

In order to re-enter CAN bus communication enabled state, eleven recessive bits must be received after HCAN sleep mode was cleared.

Clearing by Software: HCAN sleep mode is cleared by writing a 0 to MCR5 from the CPU.

Clearing by CAN Bus Operation: The cancellation method is selected by the MCR7 bit setting in MCR. Clearing by CAN bus operation occurs automatically when the CAN bus performs an operation and this change is detected. In this case, the first message is not stored in a mailbox; messages will be received normally from the second message onward. When a change is detected on the CAN bus in HCAN sleep mode, the bus operation interrupt flag (IRR12) is set in the interrupt register (IRR). If the bus interrupt mask (IMR12) in the interrupt mask register (IMR) is set to enable interrupts at this time, an interrupt can be sent to the CPU.

15.4.6 HCAN Halt Mode

The HCAN halt mode is provided to enable mailbox settings to be changed without performing an HCAN hardware or software reset. Figure 15.14 shows a flowchart of the HCAN halt mode.

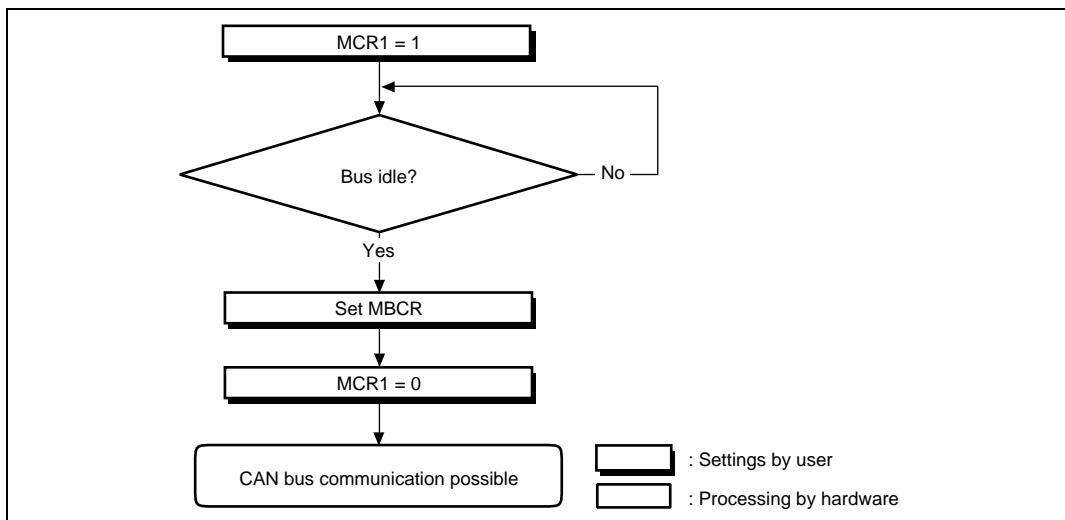

Figure 15.14 HCAN Halt Mode Flowchart

HCAN halt mode is entered by setting the halt request bit (MCR1) to 1 in the master control register (MCR). If the CAN bus is operating, the transition to HCAN halt mode is delayed until the bus becomes idle.

HCAN halt mode is cleared by clearing MCR1 to 0.

15.5 Interrupt Sources

Table 15.4 lists the HCAN interrupt sources. These sources can be masked except the reset processing interrupt by power-on reset (IRR0). Masking is implemented using the mailbox interrupt mask register (MBIMR), interrupt mask register (IMR), and IRQ enable register (IER). For details on the interrupt vector of each interrupt source, refer to section 5, Interrupt Controller.

Table 15.4 HCAN Interrupt Sources

Name	Description	Interrupt Flag	DTC Activation
ERS0/OVR0	Error passive interrupt ($TEC \geq 128$ or $REC \geq 128$)	IRR5	Not possible
	Bus off interrupt ($TEC \geq 256$)	IRR6	
	Reset processing interrupt by power-on reset	IRR0	
	Remote frame reception	IRR2	
	Error warning interrupt ($TEC \geq 96$)	IRR3	
	Error warning interrupt ($REC \geq 96$)	IRR4	
	Overload frame transmission interrupt	IRR7	
	Unread message overwrite	IRR9	
	Detection of CAN bus operation in HCAN sleep mode	IRR12	
RM0	Mailbox 0 message reception	IRR1	Possible
RM1	Mailbox 15 to 1 message reception	IRR1	Not possible
SLE0	Message transmission/transmit cancellation	IRR8	Not possible
IRQ2	Setting the RxDIE bit in HCANMON to 1 generates an IRQ2 interrupt caused by an HRxD input signal.	IRQ2F	Possible

15.6 DTC Interface

The DTC can be activated by the reception of a message in HCAN mailbox 0. When the DTC activation is set and DTC transfer ends, the RXPR0 and RFPR0 flags are automatically cleared. An interrupt request is not sent to the CPU by a reception interrupt from the HCAN. Figure 15.15 shows a DTC transfer flowchart.

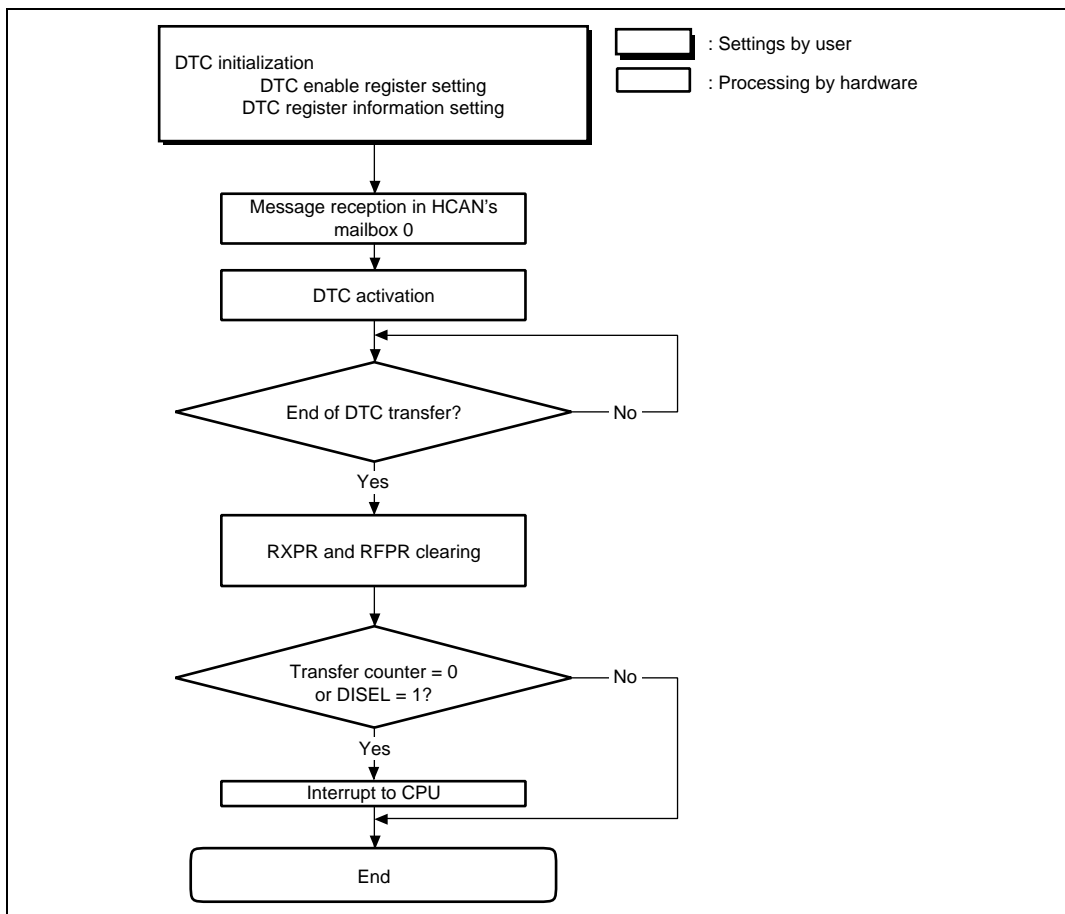

Figure 15.15 DTC Transfer Flowchart

15.7 CAN Bus Interface

A bus transceiver IC is necessary to connect the H8S/2628 Group to a CAN bus. A Philips PCA82C250 transceiver IC is recommended. If any other product is used, confirm that it is compatible with the PCA82C250. Figure 15.16 shows a sample connection diagram.

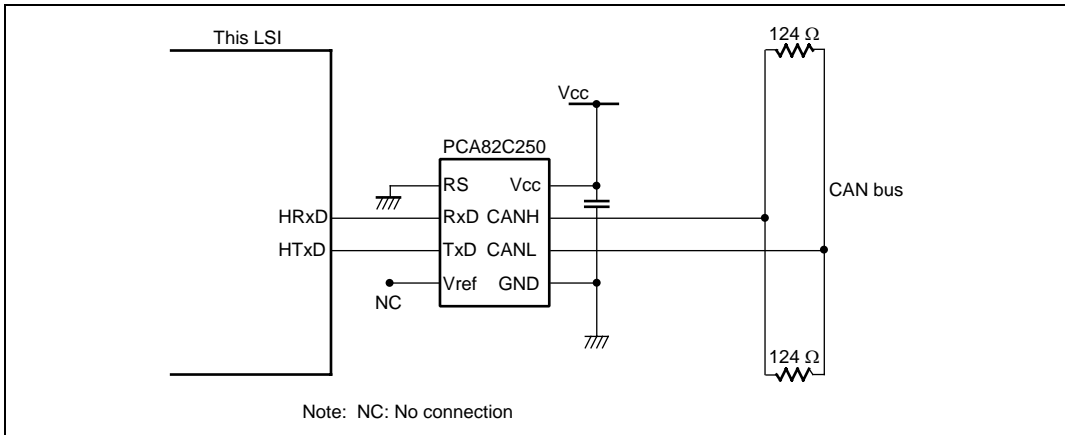

Figure 15.16 High-Speed Interface Using PCA82C250

15.8 Usage Notes

15.8.1 Module Stop Mode Setting

HCAN operation can be disabled or enabled using the module stop control register. The HCAN operation is set to be halted initially. Register access is enabled by clearing module stop mode. For details, refer to section 21, Power-Down Modes.

15.8.2 Reset

The HCAN is reset by a power-on reset, in hardware standby mode, and in software standby mode. All the registers are initialized by a reset, however mailboxes (message control (MCx[x])/message data (MDx[x])) are not initialized. Mailboxes (message control (MCx[x])/message data (MDx[x])) are initialized after power-on and at this time, their initial values are undefined. Therefore, always initialize mailboxes after a power-on reset, a transition to hardware standby mode, or software standby mode. After a power-on reset or recovery from software standby mode, the reset interrupt flag (IRR0) is automatically set. Since this bit cannot be masked in the interrupt mask register (IMR), an HCAN interrupt will be initiated immediately

after an HCAN interrupt is enabled by the interrupt controller without clearing the flag. IRR0 should therefore be cleared at initialization.

15.8.3 HCAN Sleep Mode

The bus operation interrupt flag (IRR12) in the interrupt register (IRR) is set by CAN bus operation in HCAN sleep mode. Therefore, this flag is not used by the HCAN to indicate sleep mode release. Note that the reset status bit (GSR3) in the general status register (GSR) is set even in sleep mode.

15.8.4 Interrupts

When the mailbox interrupt mask register (MBIMR) is set, the interrupt registers (IRR8, 2, 1) are not set by reception completion, transmission completion, or transmission cancellation of the set mailboxes.

15.8.5 Error Counters

In the case of error active and error passive, REC and TEC perform count up and down normally. In the bus-off state, 11-bit recessive sequences are counted (REC + 1) using REC. When REC reaches 96 during the count, IRR4 and GSR1 are set.

15.8.6 Register Access

Byte or word access can be performed for all HCAN registers. Longword access should be avoided.

15.8.7 HCAN Medium-Speed Mode

In medium-speed mode, the HCAN registers cannot be read/written.

15.8.8 Register Hold in Standby Modes

All HCAN registers are initialized in hardware standby mode and software standby mode.

15.8.9 Use on Bit Manipulation Instructions

Since the HCAN status flag is cleared by writing 1, do not use the bit manipulation instructions to clear the flag. To clear the flag, use the MOV instructions and write 1 only to the bit to be cleared.

15.8.10 HCAN TXCR Operation

1. When the transmit wait cancel register (TXCR) is used to cancel a transmit wait message in a transmit wait mailbox, the corresponding bit to TXCR and the transmit wait register (TXPR) may not be cleared even if transmission is canceled. This occurs when the following conditions are all satisfied.

Conditions:

- The HRxD pin is stacked to 1 because of a CAN bus error, etc.
- There is at least one mailbox waiting for transmission or being transmitted.
- The message transmission in a mailbox being transmitted is canceled by TXCR.

If this occurs, transmission is canceled. However, since TXPR and TXCR states are indicated wrongly that a message is being cancelled, transmission cannot be restarted even if the stack state of the HRxD pin is canceled and the CAN bus recovers the normal state. If there are at least two transmission messages, a message which is not being transmitted is canceled and a message being transmitted retains its state.

To avoid this, one of the following countermeasures must be executed.

Countermeasures:

- Transmission must not be canceled by TXCR. When transmission is normally completed after the CAN bus has recovered, TXPR is cleared and the HCAN recovers the normal state.
 - To cancel transmission, the corresponding bit to TXCR must be written to 1 continuously until the bit becomes 0. TXPR and TXCR are cleared and the HCAN recovers the normal state.
2. When the bus-off state is entered while TXPR is set and the transmit wait state is entered, the internal state machine does not operate even if TXCR is set during the bus-off state. Therefore transmission cannot be canceled. The message can be canceled when one message is transmitted or a transmission error occurs after the bus-off state is recovered. To clear a message after the bus-off state is recovered, the following countermeasure must be executed.

Countermeasure:

- A transmit wait message must be cleared by resetting the HCAN during the bus-off period. To reset the HCAN, the module stop bit (MSTPC3 in MSTPCRC) must be set or cleared. In this case, the HCAN is entirely reset. Therefore the initial settings must be made again.

15.8.11 HCAN Transmit Procedure

When transmission is set while the bus is in the idle state, if the next transmission is set or the set transmission is canceled under the following conditions within 50 μ s, the transmit message ID of being set may be damaged.

- When the second transmission has the message whose priority is higher than the first one.
- When the message of the highest priority is canceled in the first transmission.

Make whichever setting shown below to avoid the message IDs from being damaged.

- Set transmission in one TXPR. After transmission of all transmit messages is completed, set transmission again (mass transmission setting). The interval between transmission settings should be 50 μ s or longer.
- Make the transmission setting according to the priority of transmit messages.
- Set the interval to be 50 μ s or longer between TXPR and another TXPR or between TXPR and TXCR.

Table 15.5 Interval Limitation between TXPR and TXPR or between TXPR and TXCR

Baud Rate (bps)	Set Interval (μ s)
1 M	50
500 k	50
250 k	50

15.8.12 Canceling HCAN Reset and HCAN Sleep Mode

Before canceling the software reset for HCAN or HCAN sleep mode ($MCR0 = 0$ or $MCR5 = 0$), confirm that the reset status bit (GSR3) is set to 1.

15.8.13 Accessing Mailbox in HCAN Sleep Mode

The mailboxes should not be accessed in HCAN sleep mode. If mailboxes are accessed in HCAN sleep mode, the CPU may stop. When registers are accessed in HCAN sleep mode, the CPU does not stop. When mailboxes are accessed in modes other than HCAN sleep mode, the CPU does not stop.

Section 16 Synchronous Serial Communication Unit (SSU)

This LSI has two independent synchronous serial communication unit (SSU) channels. The SSU has master mode in which this LSI outputs clocks as a master device for synchronous serial communication and slave mode in which clocks are input from an external device for synchronous serial communication. Synchronous serial communication can be performed with devices having different clock polarity and clock phase. Figure 16.1 is a block diagram of the SSU.

16.1 Features

- Choice of master mode or slave mode
- Choice of standard mode or bidirectional mode
- Synchronous serial communication with devices with different clock polarity and clock phase
- Choice of 8/16/32-bit width of transmit/receive data
- Full-duplex communication capability
The shift register is incorporated, enabling transmission and reception to be executed simultaneously.
- Continuous serial communication
- Choice of LSB-first or MSB-first transfer
- Choice of a clock source
 $\phi/2$, $\phi/4$, $\phi/8$, $\phi/16$, $\phi/32$, $\phi/64$, $\phi/128$, $\phi/256$, or external clock
- Five interrupt sources
transmit-end, transmit-data-register-empty, receive-data-register-full, overrun-error, and conflict error
- Module stop mode can be set

Figure 16.1 shows a block diagram of the SSU.

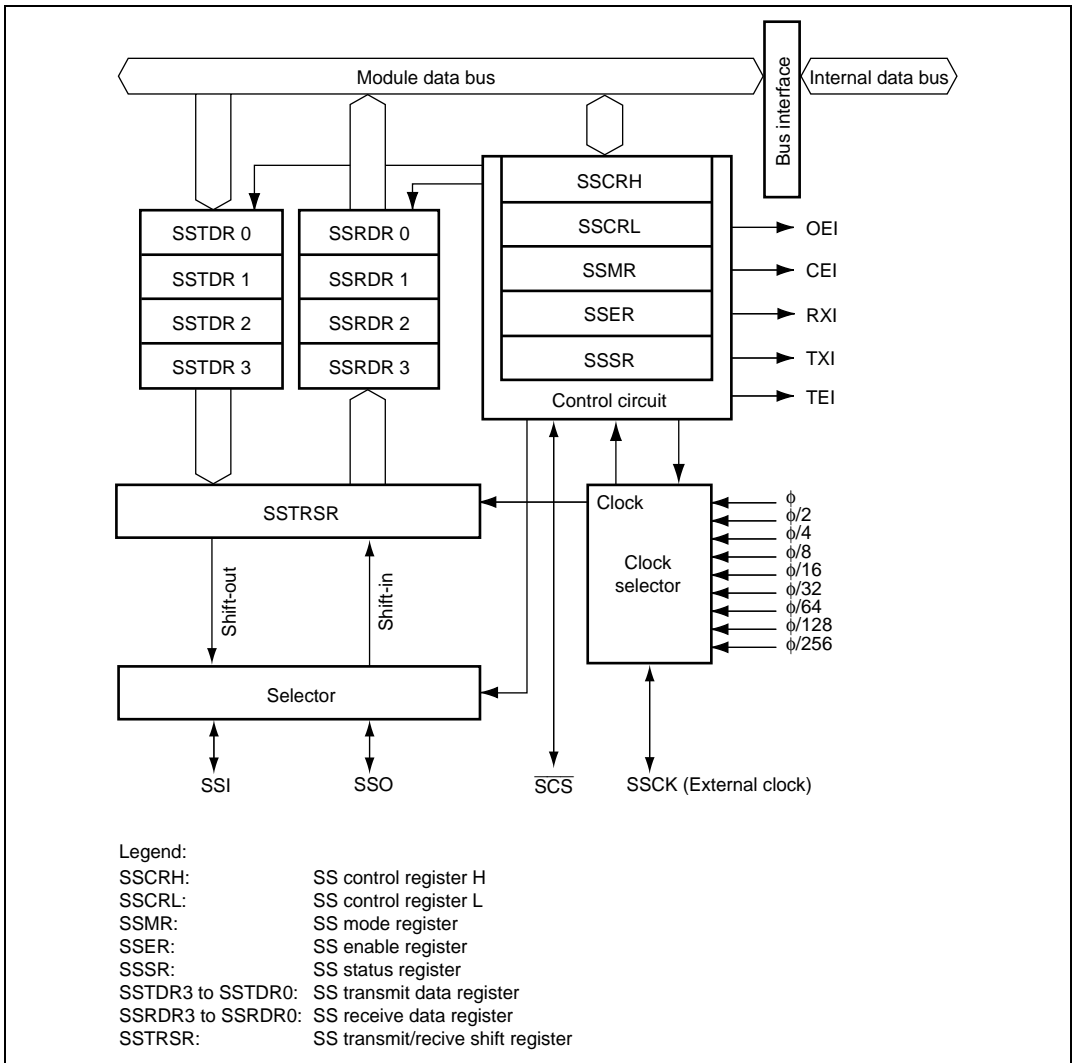

Figure 16.1 Block Diagram of SSU

16.2 Input/Output Pins

Table 16.1 shows the SSU pin configuration.

Table 16.1 Pin Configuration

Name	Symbol	I/O	Function
SSU clock	SSCK	I/O	SSU clock input/output
SSU receive data input	SSI	I/O	SSU receive data input/output
SSU transmit data output	SSO	I/O	SSU transmit data input/output
SSU chip select input/output	$\overline{\text{SCS}}$	I/O	SSU chip select input/output

16.3 Register Descriptions

The SSU has the following registers.

- SS control register H (SSCRH)
- SS control register L (SSCRL)
- SS mode register (SSMR)
- SS enable register (SSER)
- SS status register (SSSR)
- SS transmit data register 3 to 0 (SSTDR3 to SSTDR0)
- SS receive data register 3 to 0 (SSRDR3 to SSRDR0)

16.3.1 SS Control Register H (SSCRH)

SSCRH specifies master/slave device selection, bidirectional mode enable, SSO pin output value selection, SSCK pin selection, and \overline{SCS} pin selection.

Bit	Bit Name	Initial Value	R/W	Description
7	MSS	0	R/W	<p>Master/Slave Device Selection</p> <p>Selects that this module is used in master mode or slave mode. When master mode is selected, transfer clocks are output from the SSCK pin. When the CE bit in SSSR is set, this bit is automatically cleared.</p> <p>0: Slave mode is selected 1: Master mode is selected</p>
6	BIDE	0	R/W	<p>Bidirectional Mode Enable</p> <p>Selects that both serial data input pin and output pin are used or one of them is used. However, transmission and reception are not performed simultaneously when bidirectional mode is selected. For details, section 16.4.3, Relationship between Data I/O Pins and Shift Register.</p> <p>0: Standard mode (two pins are used as data input and output) 1: Bidirectional mode (one pin is used for data input and output)</p>
5	—	0	—	<p>Reserved</p> <p>The write value should always be 0.</p>
4	SOL	0	R/W	<p>Serial Data Output Value Selection</p> <p>The output level of serial data, which retains that of the last bit, can be modified by operating this bit before or after transmission. When modifying the output level, use the MOV instruction after clearing the SOLP bit to 0. Since writing to this bit during data transmission causes malfunctions, this bit should not be modified.</p> <p>0: Serial data output is modified to low level 1: Serial data output is modified to high level</p>

Bit	Bit Name	Initial Value	R/W	Description
3	SOLP	1	R/W	<p>SOL Bit Write Protect</p> <p>When modifying the output level of serial data, use the MOV instruction after setting SOL to 1 and clearing SOLP to 0, or by clearing SOL and SOLP to 0.</p> <p>0: Output level can be modified by the SOL value 1: Output level cannot be modified by the SOL value. This bit is always read as 1</p>
2	SCKS	0	R/W	<p>SSCK Pin Selection</p> <p>Selects that the SSCK pin functions as a port or a serial clock pin. When MSS = 1, the SSCK pin functions as a serial clock output pin regardless of the setting of this bit.</p> <p>0: Functions as an I/O port 1: Functions as a serial clock</p>
1	CSS1	0	R/W	\overline{SCS} Pin Selection
0	CSS0	0	R/W	<p>Select that the \overline{SCS} pin functions as a port or \overline{SCS} input or output. However, when MSS = 0, the \overline{SCS} pin functions as an input pin regardless of the CSS1 and CSS0 settings.</p> <p>00: I/O port 01: Functions as \overline{SCS} input 10: Functions as \overline{SCS} automatic input/output (however, functions as \overline{SCS} input before and after transfer and outputs a low level during transfer) 11: Functions as \overline{SCS} automatic output (however, outputs a high level before and after transfer and outputs a low level during transfer)</p>

16.3.2 SS Control Register L (SSCRL)

SSCRL selects software reset and transmit/receive data width.

Bit	Bit Name	Initial Value	R/W	Description
7, 6	—	All 0	—	Reserved The write value should always be 0.
5	SRES	0	R/W	Software Reset Setting this bit to 1 forcibly resets the SSU internal sequencer. After that, this bit is automatically cleared. The ORER, TEND, TDRE, RDRF, and CE bits in SSSR and the TE and RE bits in SSER are also initialized. Values of other bits for SSU registers are held. To stop transfer, set this bit to 1 to reset the SSU internal sequencer.
4 to 2	—	All 0	—	Reserved The write value should always be 0.
1	DATS1	0	R/W	Transmit/Receive Data Length Selection
0	DATS0	0	R/W	Select serial data length from 8, 16, and 32 bits. 00: 8 bits 01: 16 bits 10: 32 bits 11: Setting invalid

16.3.3 SS Mode Register (SSMR)

SSMR selects the MSB first/LSB first, clock phase, clock polarity, and clock rate of synchronous serial communication.

Bit	Bit Name	Initial Value	R/W	Description
7	MLS	0	R/W	MSB First/LSB First Selects the serial data is transmitted in MSB first or LSB first. 0: LSB first 1: MSB first
6	CPOS	0	R/W	Clock Polarity Selection Selects SSCK clock polarity. 0: High output in idle mode, and low output in active mode 1: Low output in idle mode, and high output in active mode
5	CPHS	0	R/W	Clock Phase Selection Selects SSCK clock phase. 0: Data changes at the first edge 1: Data is latched at the first edge
4, 3	—	All 0	—	Reserved The write value should always be 0.
2	CKS2	0	R/W	Transfer Clock Rate Selection
1	CKS1	0	R/W	Select the transfer clock rate (prescaler division rate) when a master mode is selected.
0	CKS0	0	R/W	000: $\phi/2$ 001: $\phi/4$ 010: $\phi/8$ 011: $\phi/16$ 100: $\phi/32$ 101: $\phi/64$ 110: $\phi/128$ 111: $\phi/256$

16.3.4 SS Enable Register (SSER)

SSER performs transfer/receive control of synchronous serial communication and setting of interrupt enable.

Bit	Bit Name	Initial Value	R/W	Description
7	TE	0	R/W	Transmit Enable When this bit is set to 1, transmission is enabled.
6	RE	0	R/W	Receive Enable When this bit is set to 1, reception is enabled.
5, 4	—	All 0	—	Reserved The write value should always be 0.
3	TEIE	0	R/W	Transmit End Interrupt Enable When this bit is set to 1, TEI interrupt request is enabled.
2	TIE	0	R/W	Transmit Interrupt Enable When this bit is set to 1, TXI interrupt request is enabled.
1	RIE	0	R/W	Receive Interrupt Enable When this bit is set to 1, RXI interrupt request is enabled.
0	CEIE	0	R/W	Conflict Error Interrupt Enable When this bit is set to 1, CEI interrupt request is enabled.

16.3.5 SS Status Register (SSSR)

SSSR is a status flag register for interrupts.

Bit	Bit Name	Initial Value	R/W	Description
7	—	0	—	Reserved The write value should always be 0.
6	ORER	0	R/W	<p>Overrun Error</p> <p>If the next data is received while RDRF = 1, an overrun error occurs, indicating abnormal termination. SSRDR stores 1-frame receive data before an overrun error occurs and loses data received later. While ORER = 1, continuous serial reception cannot be continued. Serial transmission cannot be continued, either.</p> <p>[Setting condition]</p> <ul style="list-style-type: none"> When the next reception data is transferred to SSRDR while RDRF = 1 <p>[Clearing condition]</p> <ul style="list-style-type: none"> When 0 is written to ORER after reading ORER = 1
5, 4	—	All 0	—	Reserved The write value should always be 0.
3	TEND	1	R	<p>Transmit End</p> <p>[Setting condition]</p> <ul style="list-style-type: none"> When the last bit of transmit data is transmitted with TDRE = 1 <p>[Clearing conditions]</p> <ul style="list-style-type: none"> When 0 is written to the TEND bit after reading TEND = 1 When data is written to SSTDR

Bit	Bit Name	Initial Value	R/W	Description
2	TDRE	1	R/W	<p>Transmit Data Register Empty</p> <p>Indicates whether or not SSTDR contains transmit data.</p> <p>[Setting conditions]</p> <ul style="list-style-type: none">• When the TE bit in SSER is 0• When data is transferred from SSTDR to SSTRSR and SSTDR is ready to be written to. <p>[Clearing conditions]</p> <ul style="list-style-type: none">• When 0 is written to the TDRE bit after reading TDRE = 1• When data is written to SSTDR with TE = 1
1	RDRF	0	R/W	<p>Receive Data Register Full</p> <p>Indicates whether or not SSRDR contains received data.</p> <p>[Setting condition]</p> <ul style="list-style-type: none">• When receive data is transferred from SSTRSR to SSRDR after successful data reception <p>[Clearing conditions]</p> <ul style="list-style-type: none">• When 0 is written to RDRF after reading RDRF = 1• When received data is read from SSRDR

Bit	Bit Name	Initial Value	R/W	Description
0	CE	0	R/W	<p>Conflict/Incomplete Error</p> <p>Indicates that a conflict error has occurred when 0 is externally input via the $\overline{\text{SCS}}$ pin with $\text{MSS} = 1$.</p> <p>If the $\overline{\text{SCS}}$ pin level changes to 1 during slave operation, an incomplete error occurs because it is determined that a master device has terminated the transfer. Data reception does not continue while the CE bit is set to 1. Reset the SSU internal sequencer by setting the SRES bit in SSCRL to 1 before resuming transfer after incomplete error.</p> <p>[Setting conditions]</p> <ul style="list-style-type: none"> • When a low level is input to the $\overline{\text{SCS}}$ pin in master device mode (MSS in SSCRH = 1) • When a 1 is input to the $\overline{\text{SCS}}$ pin during slave device mode (MSS in SSCRH = 0) transfer <p>[Clearing condition]</p> <ul style="list-style-type: none"> • When 0 is written to the CE bit after reading $\text{CE} = 1$

16.3.6 SS Transmit Data Register 3 to 0 (SSTDR3 to SSTDR0)

SSTDR is an 8-bit register that stores transmit data. When 8-bit data length is selected by bits DATS1 and DATS0 in SSCRL, SSTDR0 is valid. When 16-bit data length is selected, SSTDR0 and SSTDR1 are valid. When 32-bit data length is selected, SSTDR3 to SSTDR0 are valid. Do not attempt to access invalid SS transmit data registers.

When the SSU detects that SSTRSR is empty, it transfers the transmit data written in SSTDR to SSTRSR and starts transmission. If the next transmit data has already been written to SSTDR during serial transmission, the SSU transfers the written data to SSTRSR to continue transmission. Although SSTDR can be read or written to by the CPU and DTC at all times, to achieve reliable serial transmission, write transmit data to SSTDR after confirming that the TDRE bit in SSSR is set to 1. The initial value of this register is H'00.

16.3.7 SS Receive Data Register 3 to 0 (SSRDR3 to SSRDR0)

SSRDR is an 8-bit register that stores receive data. When 8-bit data length is selected by bits DATS1 and DATS0 in SSCRL, SSRDR0 is valid. When 16-bit data length is selected, SSRDR0 and SSRDR1 are valid. When 32-bit data length is selected, SSRDR3 to SSRDR0 are valid. Do not attempt to access invalid SS receive data registers.

When the SSU has received 1-byte data, it transfers the received serial data from SSTRSR to SSRDR where it is stored. After this, SSTRSR is receive-enabled. Since SSTRSR and SSRDR function as a double buffer in this way, continuous receive operations can be performed. Read SSRDR after confirming that the RDRF bit in SSSR is set to 1. SSRDR cannot be written to by the CPU. The initial value of this register is H'00.

16.3.8 SS Shift Register (SSTRSR)

SSTRSR is a shift register that transmits and receives serial data.

When data from SSTDR to SSTRSR is transferred with MLS = 0, bit 0 of transmit data is bit 0 in the SSTDR contents (LSB first communication). When data from SSTDR to SSTRSR is transferred with MLS = 1, bit 0 of transmit data is bit 7 in the SSTDR contents (MSB first communication). To perform serial data transmission, the SSU transfers data starting from LSB (bit 0) in SSTRSR to the SSO pin.

In reception, the SSU sets serial data that has been input from the SSI pin to SSTRSR starting from LSB (bit 0) and converts it into parallel data. When 1-byte data has been received, the SSTRSR contents are automatically transferred to SSRDR. SSTRSR cannot be directly accessed by the CPU.

16.4 Operation

16.4.1 Transfer Clock

A transfer clock can be selected from eight internal clocks and an external clock. When using this module, set SCKS in SSCRH to 1 to select the SSCK pin as a serial clock. When MSS in SSCRH is 1, an internal clock is selected and the SSCK pin is used as an output pin. When transfer is started, the clock with the transfer rate set by bits CKS2 to CKS0 in SSMR is output from the SSCK pin. When MSS = 0, an external clock is selected and the SSCK pin is used as an input pin.

16.4.2 Relationship of Clock Phase, Polarity, and Data

The relationship of clock phase, polarity, and transfer data depends on the combination of CPOS and CPHS in SSMR. Figure 16.2 shows the relationship.

Setting the MLS bit specifies that MSB or LSB first communication. When MLS = 0, data is transferred from the LSB to MSB. When MLS = 1, data is transferred from the MSB to LSB.

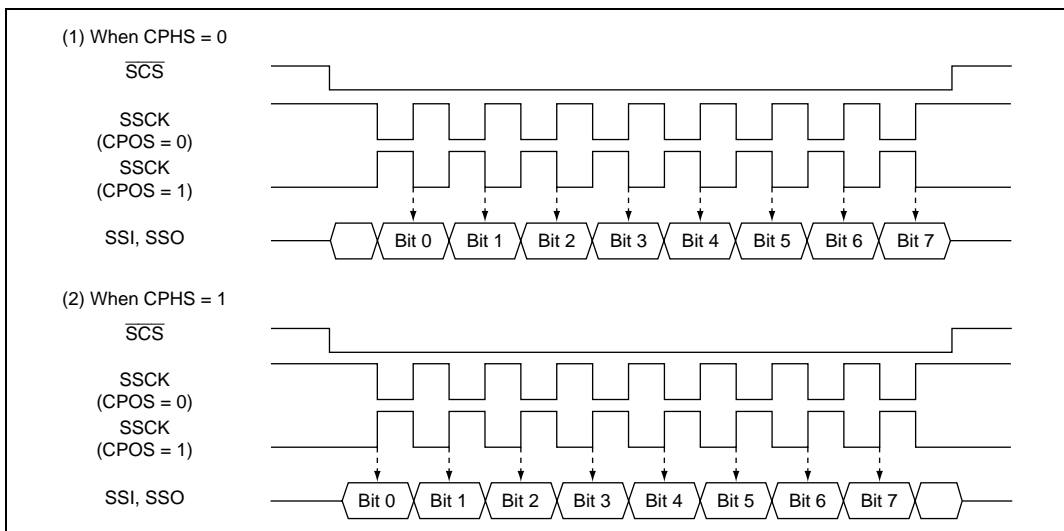

Figure 16.2 Relationship of Clock Phase, Polarity, and Data

16.4.3 Relationship between Data I/O Pins and the Shift Register

The connection between data I/O pins and the shift register (SSTRSR) depends on the combination of the MSS and BIDE bits in SSCRH. Figure 16.3 shows the connection.

The SSU transmits serial data from the SSO pin and receives serial data from the SSI pin when operating with $BIDE = 0$ and $MSS = 1$ (standard, master mode) (see figure 16.3 (1)). The SSU transmits serial data from the SSI pin and receives serial data from the SSO pin when operating with $BIDE = 0$ and $MSS = 0$ (standard, slave mode) (see figure 16.3 (2)).

The SSU transmits and receives serial data from the SSO pin regardless of master or slave mode when operating with $BIDE = 1$ (bidirectional mode) (see figure 16.3 (3) and (4)).

However, even if both the TE and RE bits are set to 1, transmission and reception are not performed simultaneously. Either the TE or RE bit must be selected.

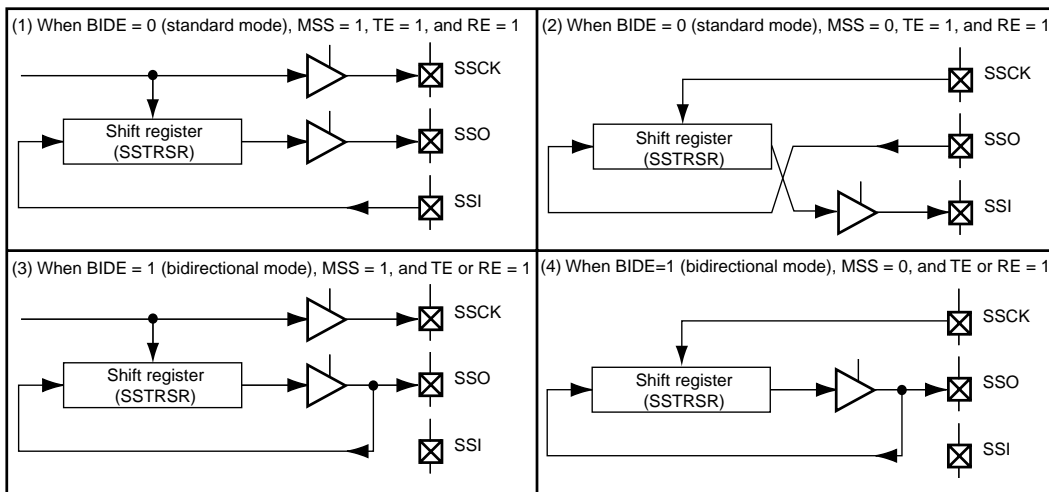

Figure 16.3 Relationship between Data I/O Pins and the Shift Register

16.4.4 Data Transmission and Data Reception

The SSU performs data communications using the bus with four lines: the clock line (SSCK), data input (SSI or SSO), data output (SSI or SSO), and chip select (\overline{SCS}).

The SSU also supports bidirectional mode in which the data is output and input using one pin.

SSU Initialization

Figure 16.4 shows an example of the SSU initialization. Before transmitting and receiving data, first clear the TE and RE bits in SSER to 0, then initialize the SSU.

Note: When the operating mode or transfer format is changed for example, the TE and RE bits must be cleared to 0. When the TE bit is cleared to 0, the TDRE bit is set to 1. Note that clearing the RE bit to 0 does not initialize the values of the RDRF and ORER bits or the contents of SSRDR.

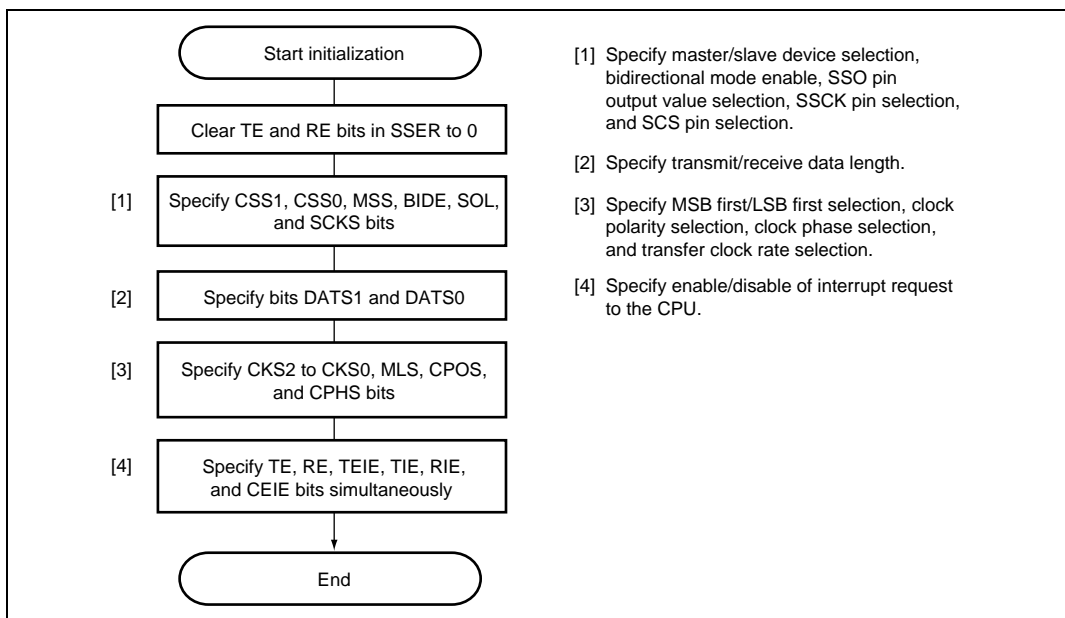

Figure 16.4 Example of SSU Initialization

Data Transmission

Figure 16.5 shows an example of transmission operation, and figure 16.6 shows an example of data transmission flowchart.

When transmitting data, the SSU operates as shown below.

In master device mode, the SSU outputs a transfer clock and data. In slave device mode, when a low level signal is input to the \overline{SCS} pin and a transfer clock is input to the SSCK pin, the SSU outputs data in synchronization with the transfer clock.

Writing transmit data to SSTDR after initialization of the SSU automatically clears the TDRE bit in SSSR to 0, and the contents of SSTDR is transferred to SSTRSR. After that, the SSU sets the TDRE bit to 1 and starts transmission. At this time, if the TIE bit in SSER is set to 1, a TXI interrupt is generated.

When 1-frame data has been transferred with the TDRE bit cleared to 0, the SSTDR contents are transferred to SSTRSR to start the next transmission. When the 8th bit of transmit data has been transferred with the TDRE bit set to 1, the TEND bit in SSSR is set to 1 and the state is retained. At this time, if the TEIE bit is set to 1, a TEI interrupt is generated. After transmission, the output level of the SSCK pin is fixed at a high level when CPOS = 0 and at a low level when CPOS = 1.

While the ORER bit in SSSR is set to 1, transmission is not performed. Check that the ORER bit is cleared to 0.

(1) When 8-bit data length is selected (SSTDR0 is valid) with CPOS = 0 and CPHS = 0

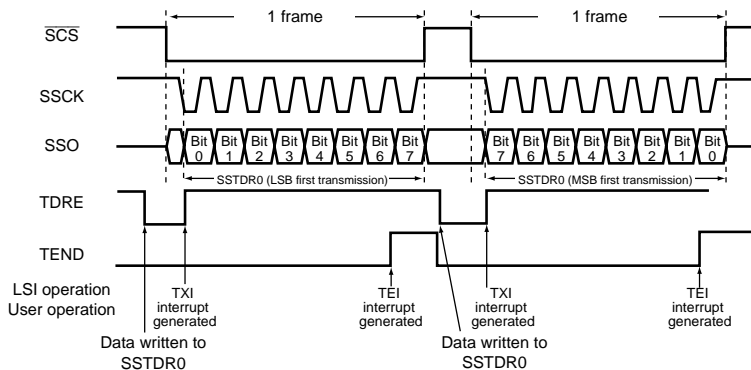

(2) When 16-bit data length is selected (SSTDR0 and SSTDR1 are valid) with CPOS = 0 and CPHS = 0

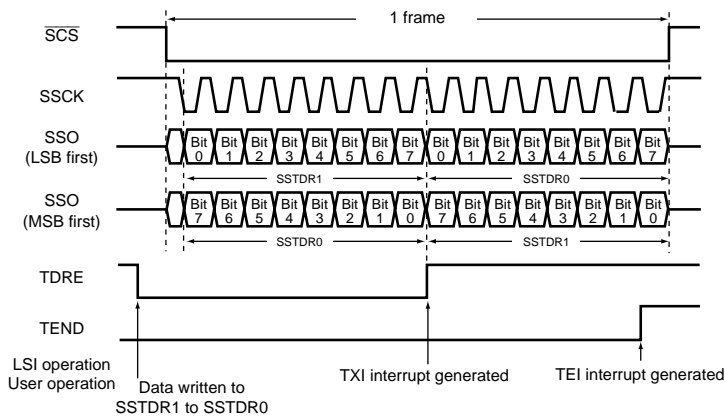

(3) When 32-bit data length is selected (SSTDR0, SSTDR1, SSTDR2, and SSTDR3 are valid) with CPOS = 0 and CPHS = 0

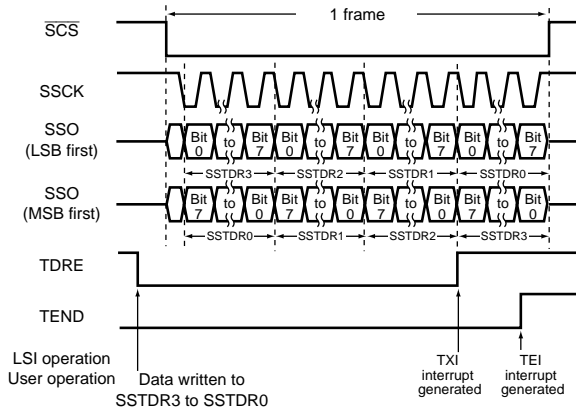

Figure 16.5 Example of Transmission Operation

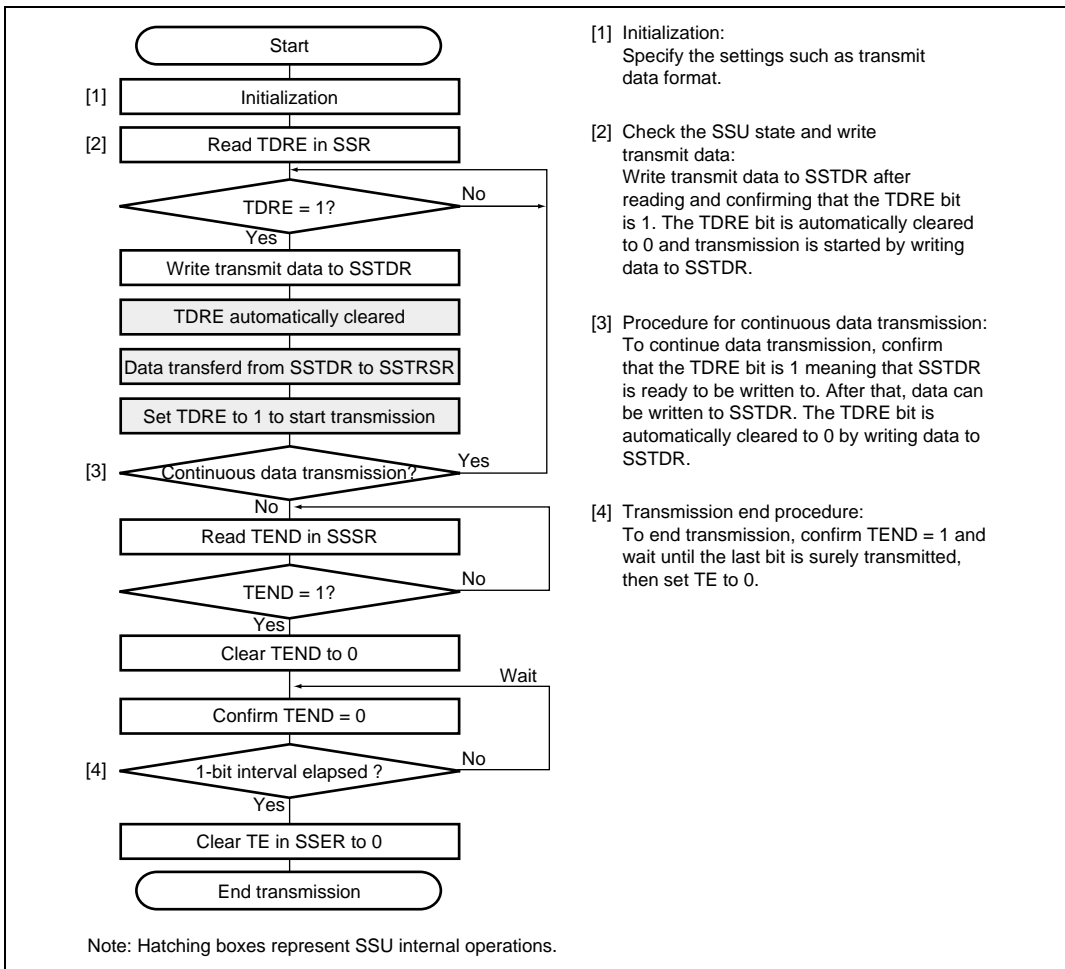

Figure 16.6 Example of Data Transmission Flowchart

Data Reception

Figure 16.7 shows an example of reception operation, and figure 16.8 shows an example of data reception flowchart.

When receiving data, the SSU operates as shown below.

After initialization, the SSU dummy-reads SSRDR and data reception is started.

In master device mode, the SSU outputs a transfer clock and receives data. In slave device mode, when a low level signal is input to the \overline{SCS} pin and a transfer clock is input to the SSCK pin, the SSU receives data in synchronization with the transfer clock.

When 1-frame data has been received, the received data is stored in SSRDR. At this time, if the RIE bit is set to 1, an RXI interrupt is generated. The RDRF bit is automatically cleared to 0 by reading SSRDR.

(1) When 8-bit data length is selected (SSRDR0 is valid) with CPOS = 0 and CPHS = 0

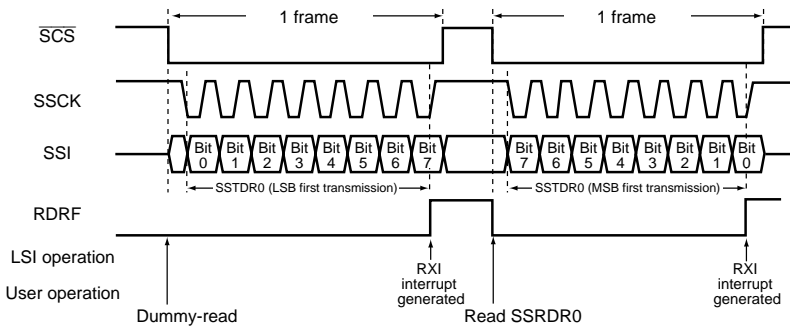

(2) When 16-bit data length is selected (SSRDR0 and SSRDR1 are valid) with CPOS = 0 and CPHS = 0

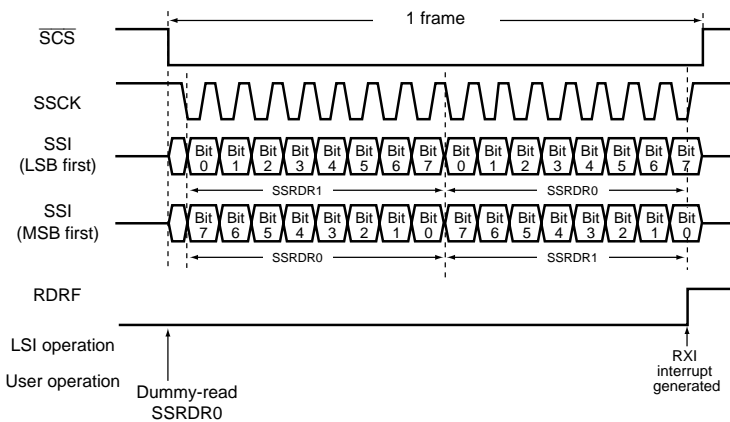

(3) When 32-bit data length is selected (SSRDR0, SSRDR1, SSRDR2, and SSRDR3 are valid) with CPOS = 0 and CPHS = 0

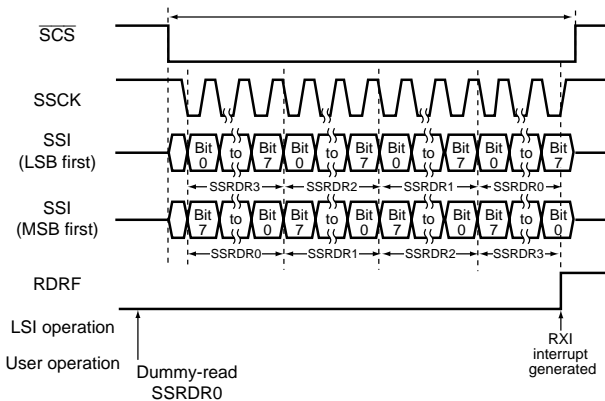
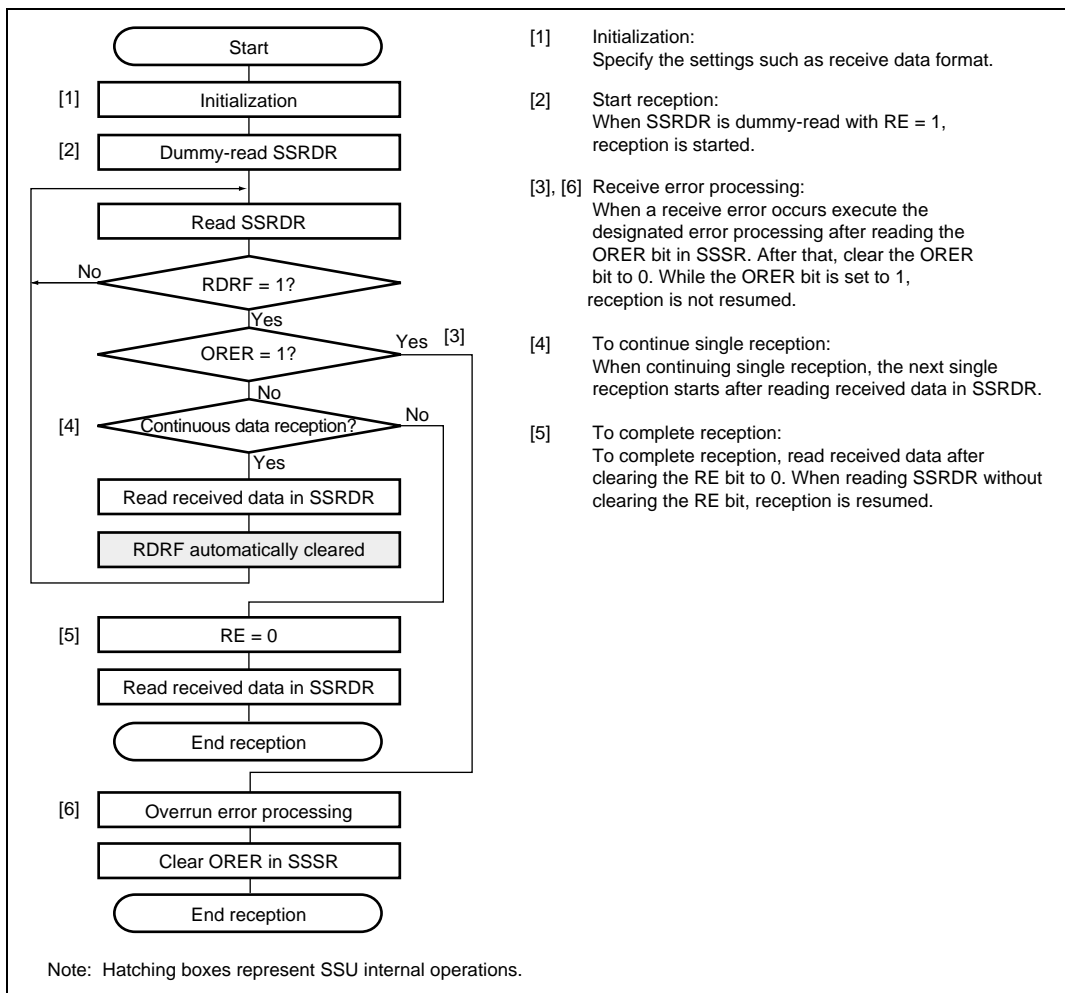

Figure 16.7 Example of Reception Operation



- [1] Initialization:
Specify the settings such as receive data format.
- [2] Start reception:
When SSRDR is dummy-read with RE = 1, reception is started.
- [3], [6] Receive error processing:
When a receive error occurs execute the designated error processing after reading the ORER bit in SSSR. After that, clear the ORER bit to 0. While the ORER bit is set to 1, reception is not resumed.
- [4] To continue single reception:
When continuing single reception, the next single reception starts after reading received data in SSRDR.
- [5] To complete reception:
To complete reception, read received data after clearing the RE bit to 0. When reading SSRDR without clearing the RE bit, reception is resumed.

Figure 16.8 Example of Data Reception Flowchart

Data Transmission/Reception

Figure 16.9 shows an example of simultaneous transmission/reception operation. The data transmission/reception is performed combining the data transmission and data reception as mentioned above. The data transmission/reception is started by writing transmit data to SSTDR with $TE = RE = 1$.

When the RDRF has been set to 1 at the 8th rising edge of the transfer clock (in a case of 8-bit data length), the ORER bit in SSSR is set to 1. This indicates that an overrun error (OEI) has occurred. At this time, data transmission/reception is stopped. While the ORER bit in SSSR is set to 1, transmission/reception is not performed. To resume the transmission/reception, clear the ORER bit to 0.

Before switching transmission mode ($TE = 1$) or reception mode ($RE = 1$) to transmission/reception mode ($TE = RE = 1$), clear the TE and RE bits to 0. When starting the transfer, confirm that the TEND, RDRF, and ORER bits are cleared to 0 before setting the TE and RE bits to 1.

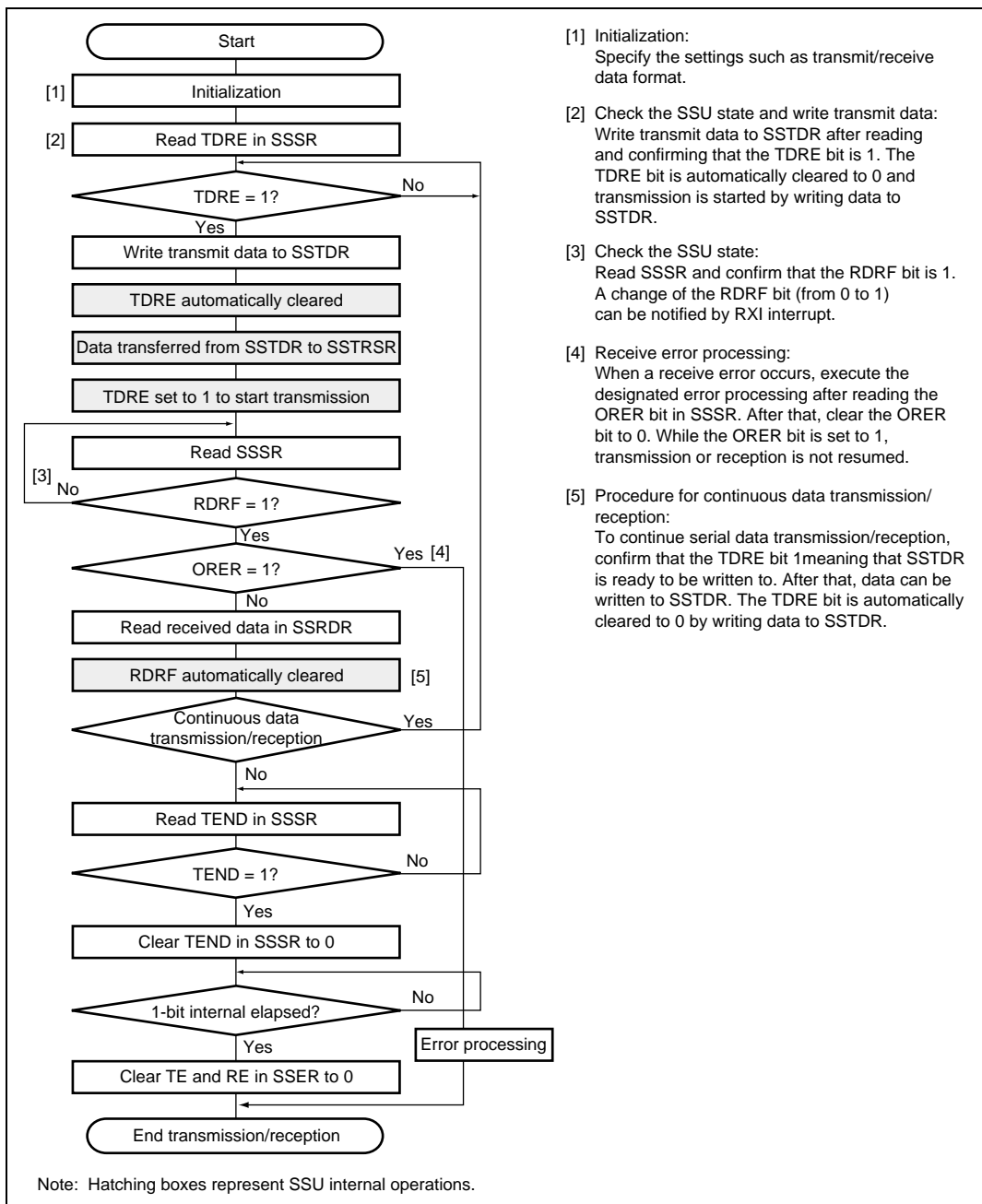

Figure 16.9 Example of Simultaneous Transmission/Reception Flowchart

16.4.5 $\overline{\text{SCS}}$ Pin Control and Conflict Error

When bits CSS1 and CSS0 in SSCRH are specified to B'10, the $\overline{\text{SCS}}$ pin functions as an input (Hi-Z) to detect conflict error. The conflict detection period starts when setting the MSS bit in SSCRH to 1 and ends when starting serial transfer. When a low level signal is input to the $\overline{\text{SCS}}$ pin within the period, a conflict error occurs. At this time, the CE bit in SSSR is set to 1 and the MSS bit is cleared to 0.

Note: While the CE bit is set to 1, transmission or reception is not resumed. Clear the CE bit to 0 before resuming the transmission or reception.

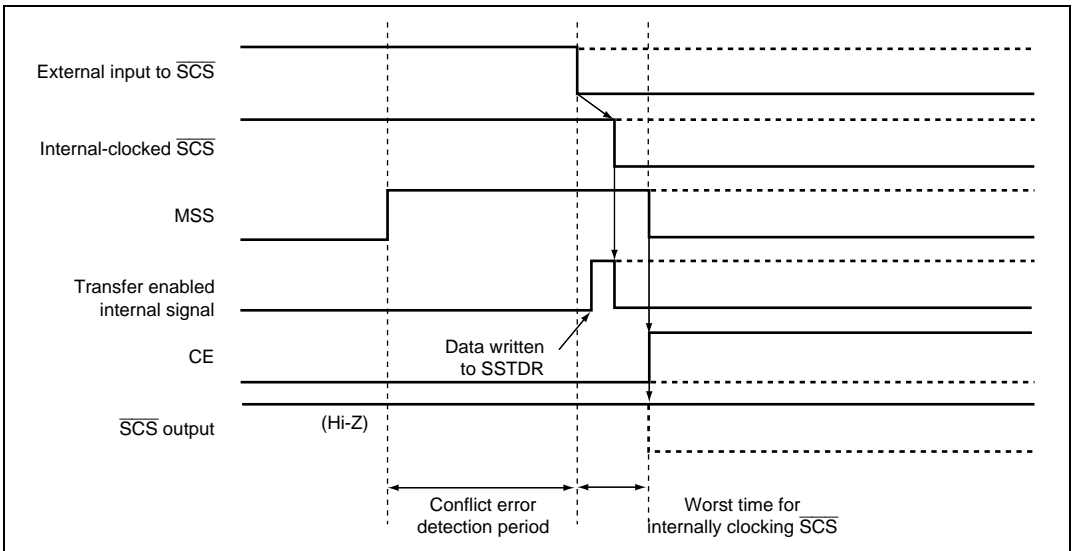

Figure 16.10 Conflict Error Detection Timing (Before Transfer Start)

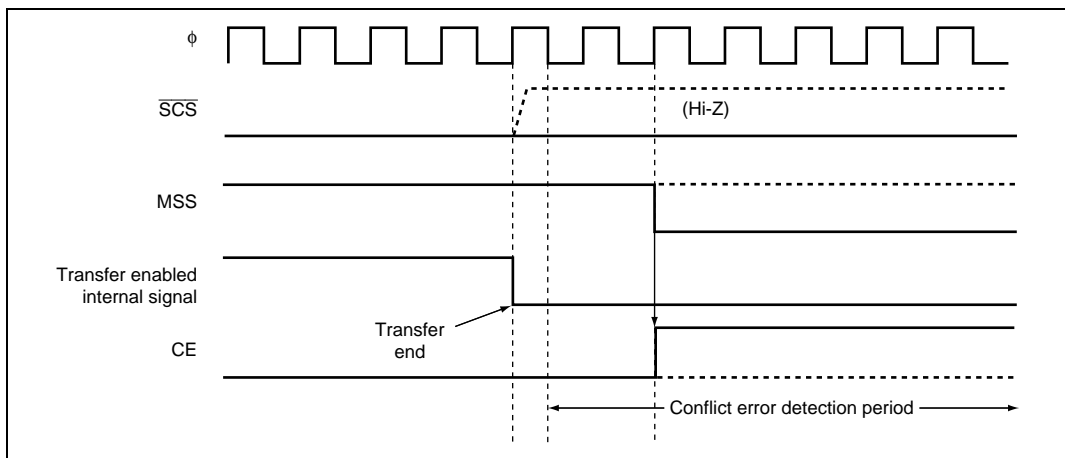

Figure 16.11 Conflict Error Detection Timing (After Transfer End)

16.5 Interrupt Requests

The SSU interrupt requests consist of transmit data register empty, transmit end, receive data register full, overrun error, and conflict error. Of these interrupt sources, transmit data register empty, transmit end, receive data register full can activate the DTC for data transfer.

The TDRE, TEND, and RDRF bits are automatically cleared to 0 by the DTC data transfer. Since these interrupt requests are allocated to four vector addresses: SSEr_i0, SSRx_i0, SSTx_i0 and SSERT_i1, the interrupt sources must be distinguished by flags. Table 16.2 lists interrupt sources.

Table 16.2 Interrupt Sources

Channel	Abbreviation	Interrupt Request	Symbol	Interrupt Condition
0	SSEr_i0	Overrun error	OEI	RIE = 1, ORER = 1
		Conflict error	CEI	CEIE = 1, CE = 1
	SSRx_i0	Receive data register full	RXI	RIE = 1, RDRF = 1
	SSTx_i0	Transmit data register empty	TXI	TIE = 1, TDRE = 1
		Transmit end	TEI	TEIE = 1, TEND = 1
1	SSERT_i1	Overrun error	OEI	RIE = 1, ORER = 1
		Conflict error	CEI	CEIE = 1, CE = 1
		Receive data register full	RXI	RIE = 1, RDRF = 1
		Transmit data register empty	TXI	TIE = 1, TDRE = 1
		Transmit end	TEI	TEIE = 1, TEND = 1

When interrupt conditions shown in table 16.2 are satisfied and the I bit in CCR is 0, the CPU executes interrupt exception processing. Clear each interrupt source in the exception processing.

16.6 Usage Note

16.6.1 Setting of Module Stop Mode

The SSU can be enabled/disabled by the module stop control register setting and is disabled by the initial value. Canceling module stop mode enables to access the SSU registers. For details, see section 21, Power-Down Modes.

Section 17 A/D Converter

This LSI includes a successive approximation type 10-bit A/D converter that allows up to sixteen analog input channels to be selected. The block diagram of the A/D converter is shown in figure 17.1.

17.1 Features

- 10-bit resolution
- Sixteen input channels
- Conversion time: 11.08 μ s per channel (at 24 MHz operation)
- Two operating modes
 - Single mode: Single-channel A/D conversion
 - Scan mode: Continuous A/D conversion on 1 to 4 channels
- Four data registers
 - Conversion results are held in a 16-bit data register for each channel
- Sample and hold function
- Three conversion start methods
 - Software
 - 16-bit timer pulse unit (TPU) conversion start trigger
 - External trigger signal
- Interrupt request
 - An A/D conversion end interrupt request (ADI) can be generated
- Module stop mode can be set

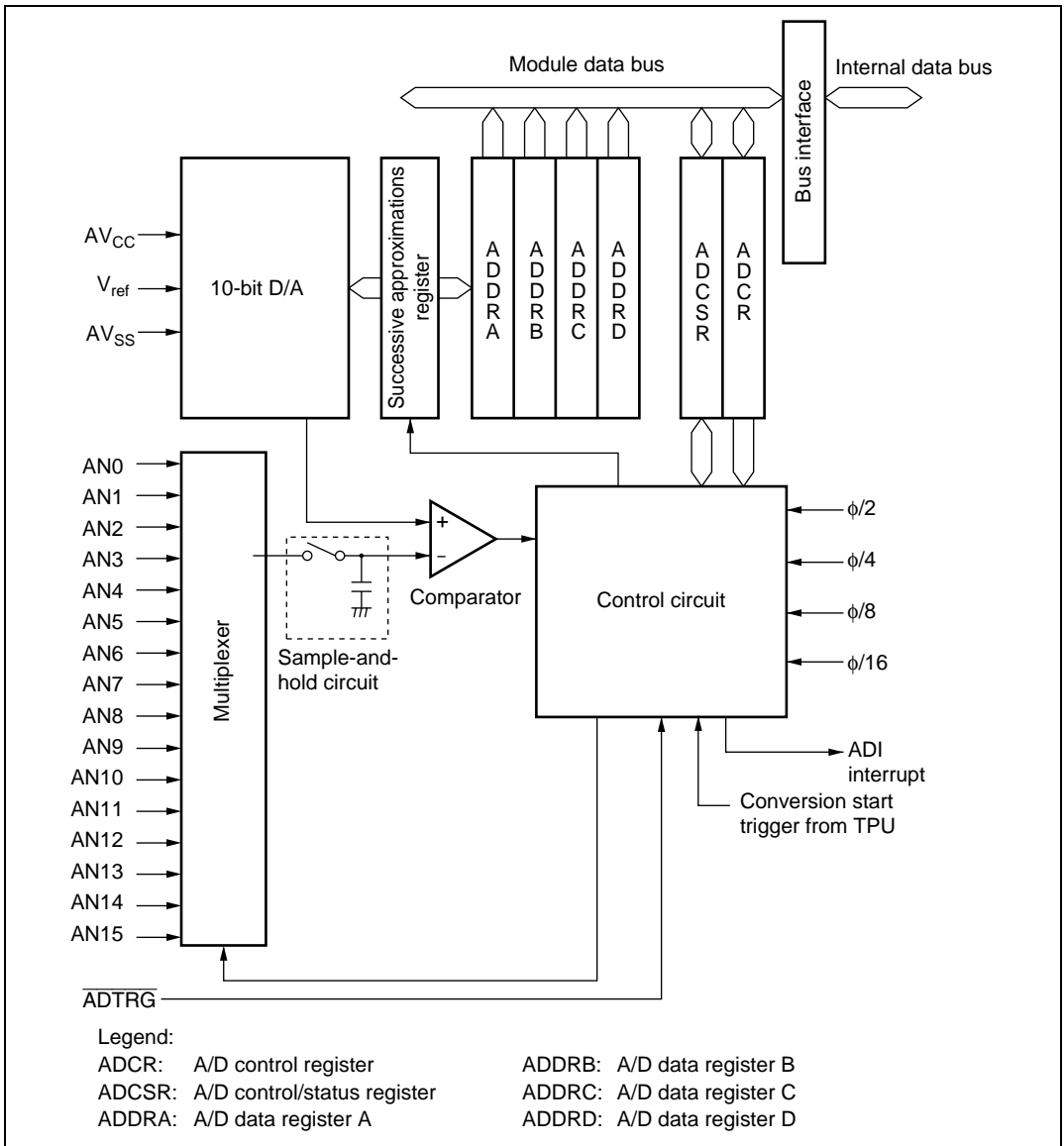

Figure 17.1 Block Diagram of A/D Converter

17.2 Input/Output Pins

Table 17.1 summarizes the input pins used by the A/D converter. 12 analog input pins are divided into three groups, each of which includes four channels; analog input pins 3 to 0 (AN3 to AN0) comprising group 0, analog input pins 7 to 4 (AN7 to AN4) comprising group 1, analog input pins 11 to 8 (AN11 to AN8) comprising group 2, and analog input pins 15 to 12 (AN15 to AN12) comprising group 3. The AV_{CC} and AV_{SS} pins are the power supply pins for the A/D converter analog section. The V_{ref} pin is the A/D conversion reference voltage pin.

Table 17.1 Pin Configuration

Pin Name	Symbol	I/O	Function
Analog power supply pin	AV _{CC}	Input	Analog section power supply and reference voltage
Analog ground pin	AV _{SS}	Input	Analog section ground and reference voltage
Reference voltage pin	V _{ref}	Input	Reference voltage of A/D conversion
Analog input pin 0	AN0	Input	Group 0 analog input pins
Analog input pin 1	AN1	Input	
Analog input pin 2	AN2	Input	
Analog input pin 3	AN3	Input	
Analog input pin 4	AN4	Input	Group 1 analog input pins
Analog input pin 5	AN5	Input	
Analog input pin 6	AN6	Input	
Analog input pin 7	AN7	Input	
Analog input pin 8	AN8	Input	Group 2 analog input pins
Analog input pin 9	AN9	Input	
Analog input pin 10	AN10	Input	
Analog input pin 11	AN11	Input	
Analog input pin 12	AN12	Input	Group 3 analog input pins
Analog input pin 13	AN13	Input	
Analog input pin 14	AN14	Input	
Analog input pin 15	AN15	Input	
A/D external trigger input pin	ADTRG	Input	External trigger input pin for starting A/D conversion

17.3 Register Description

The A/D converter has the following registers. Module stop mode for the A/D converter is specified with the MSTPA1 bit in the module stop control register (MSTPCRA). For details on the module stop control register A (MSTPCRA), refer to section 21.1.2, Module Stop Control Register A to C (MSTPCRA to MSTPCRC).

- A/D data register A (ADDRA)
- A/D data register B (ADDRB)
- A/D data register C (ADDRC)
- A/D data register D (ADDRD)
- A/D control/status register (ADCSR)
- A/D control register (ADCR)

17.3.1 A/D Data Registers A to D (ADDRA to ADDR D)

There are four 16-bit read-only ADDR registers ADDRA to ADDR D, used to store the results of A/D conversion. The ADDR registers to store conversion results for each channel are shown in table 17.2.

The converted 10-bit data is stored in bits 6 to 15 in ADDR. The lower 6 bits are always read as 0.

The data bus between the CPU and the A/D converter is 8 bits wide. The upper byte can be read directly from the CPU, however the lower byte should be read via a temporary register. The temporary register contents are transferred from the ADDR when the upper byte data is read. When reading the ADDR, always read the upper byte first, and then read the lower byte, or read in word unit. Otherwise, the read contents are not guaranteed.

Table 17.2 Analog Input Channels and Corresponding ADDR Registers

Analog Input Channel				
CH3 = 0		CH3 = 1		A/D Data Register to Store the A/D Conversion Results
Group 0 (CH2 = 0)	Group 1 (CH2 = 1)	Group 2 (CH2 = 0)	Group 3 (CH2 = 1)	
AN0	AN4	AN8	AN12	ADDRA
AN1	AN5	AN9	AN13	ADDRB
AN2	AN6	AN10	AN14	ADDRC
AN3	AN7	AN11	AN15	ADDRD

17.3.2 A/D Control/Status Register (ADCSR)

ADCSR controls A/D conversion operations.

Bit	Bit Name	Initial Value	R/W	Description
7	ADF	0	R/(W)	<p>A/D End Flag</p> <p>A status flag that indicates the end of A/D conversion.</p> <p>[Setting conditions]</p> <ul style="list-style-type: none"> • When A/D conversion ends in single mode • When A/D conversion ends on all specified channels selected in scan mode <p>[Clearing conditions]</p> <ul style="list-style-type: none"> • When 0 is written after reading ADF = 1 • When the DTC is activated by an ADI interrupt and ADDR is read
6	ADIE	0	R/W	<p>A/D Interrupt Enable</p> <p>A/D conversion end interrupt (ADI) is enabled when this bit is set to 1.</p>
5	ADST	0	R/W	<p>A/D Start</p> <p>Clearing this bit to 0 stops A/D conversion, and the A/D converter enters the wait state.</p> <p>Setting this bit to 1 starts A/D conversion. In single mode, this bit is automatically cleared to 0 when conversion on the specified channel is complete. In scan mode, conversion continues sequentially on the specified channels until this bit is cleared to 0 by software, a reset, or a transition to software standby mode, hardware standby mode or module stop mode.</p>

Bit	Bit Name	Initial Value	R/W	Description	
4	SCAN	0	R/W	Scan Mode Selects the A/D conversion operating mode. 0: Single mode 1: Scan mode	
3	CH3	0	R/W	Channel Select 0 to 3	
2	CH2	0	R/W	Select analog input channels.	
1	CH1	0	R/W	When SCAN = 0	When SCAN = 1
0	CH0	0	R/W	0000: AN0	0000: AN0
				0001: AN1	0001: AN1, AN0
				0010: AN2	0010: AN2 to AN0
				0011: AN3	0011: AN3 to AN0
				0100: AN4	0100: AN4
				0101: AN5	0101: AN5, AN4
				0110: AN6	0110: AN6 to AN4
				0111: AN7	0111: AN7 to AN4
				1000: AN8	1000: AN8
				1001: AN9	1001: AN9, AN8
				1010: AN10	1010: AN10 to AN8
				1011: AN11	1011: AN11 to AN8
				1100: AN12	1100: AN12
				1101: AN13	1101: AN13, AN12
				1110: AN14	1110: AN14 to AN12
				1111: AN15	1111: AN15 to AN12

17.3.3 A/D Control Register (ADCR)

The ADCR enables A/D conversion started by an external trigger signal.

Bit	Bit Name	Initial Value	R/W	Description
7	TRGS1	0	R/W	Timer Trigger Select 1 and 0
6	TRGS0	0	R/W	Enable the start of A/D conversion by a trigger signal. Bits TRGS0 and TRGS1 should be set while A/D conversion is stopped (ADST = 0). 00: A/D conversion is started by software 01: A/D conversion is started by TPU conversion start trigger 10: Start of A/D conversion by 8-bit timer conversion start trigger is allowed 11: A/D conversion is started by the $\overline{\text{ADTRG}}$ pin
5, 4	—	All 1	—	Reserved These bits are always read as 1.
3	CKS1	0	R/W	Clock Select 1 and 0
2	CKS0	0	R/W	Specify the A/D conversion time. The conversion time should be changed only when ADST = 0. Specify a value within the range shown in table 23.7. 00: Conversion time = 530 states (max.) 01: Conversion time = 266 states (max.) 10: Conversion time = 134 states (max.) 11: Conversion time = 68 states (max.)
1, 0	—	All 1	—	Reserved These bits are always read as 1.

17.4 Operation

The A/D converter operates by successive approximation with 10-bit resolution. It has two operating modes; single mode and scan mode. When changing the operating mode or analog input channel, clear the ADST bit in ADCSR to 0 first in order to prevent incorrect operation. The ADST bit can be set at the same time as the operating mode or analog input channel is changed.

17.4.1 Single Mode

In single mode, A/D conversion is performed only once on the specified single channel as follows.

1. A/D conversion is started when the ADST bit is set to 1 by software or external trigger input.
2. When A/D conversion is completed, the result is transferred to the A/D data register corresponding to the channel.
3. On completion of conversion, the ADF bit in ADCSR is set to 1. If the ADIE bit is set to 1 at this time, an ADI interrupt request is generated.
4. The ADST bit retains 1 during A/D conversion. When A/D conversion ends, the ADST bit is automatically cleared to 0 and the A/D converter enters the wait state. If the ADST bit is cleared to 0 during A/D conversion, the conversion is stopped and the A/D converter enters the wait state.

17.4.2 Scan Mode

In scan mode, A/D conversion is to be performed sequentially on the specified channels up to four channels as follows.

1. When the ADST bit is set to 1 by software, TPU or external trigger input, A/D conversion starts on the first channel in the group (for example, AN0 when CH3 and CH2 = 00, AN4 when CH3 and CH2 = 01, AN8 when CH3 and CH2 = 10, or AN12 when CH3 and CH2 = 11).
2. When the A/D conversion is completed on one channel, the result is sequentially transferred to the A/D data register corresponding to the channel.
3. When the conversion is completed on all the selected channels, the ADF bit in ADCSR is set to 1. If the ADIE bit is set to 1 at this time, an ADI interrupt is requested after A/D conversion ends. Then, the A/D converter restarts the conversion from the first channel in the group.
4. Steps 2 to 3 are repeated as long as the ADST bit is set to 1. When the ADST bit is cleared to 0, the A/D conversion stops and the A/D converter enters the wait state.

17.4.3 Input Sampling and A/D Conversion Time

The A/D converter includes the sample-and-hold circuit. The A/D converter samples the analog input when the A/D conversion start delay time (t_D) has passed after the ADST bit is set to 1, and then conversion is started. Figure 17.2 shows the A/D conversion timing. Table 17.3 shows the A/D conversion time.

As shown in figure 17.2, the A/D conversion time (t_{CONV}) includes t_D and input sampling time (t_{SPL}). The length of t_D varies depending on the timing of the write access to ADCSR. Therefore, the total conversion time varies within the range shown in table 17.3.

In scan mode, the values given in table 17.3 indicate the first conversion time. The second and subsequent conversion time is shown in table 17.4. In both cases, set bits CKS1 and CKS0 in ADCR within the range shown in table 23.7.

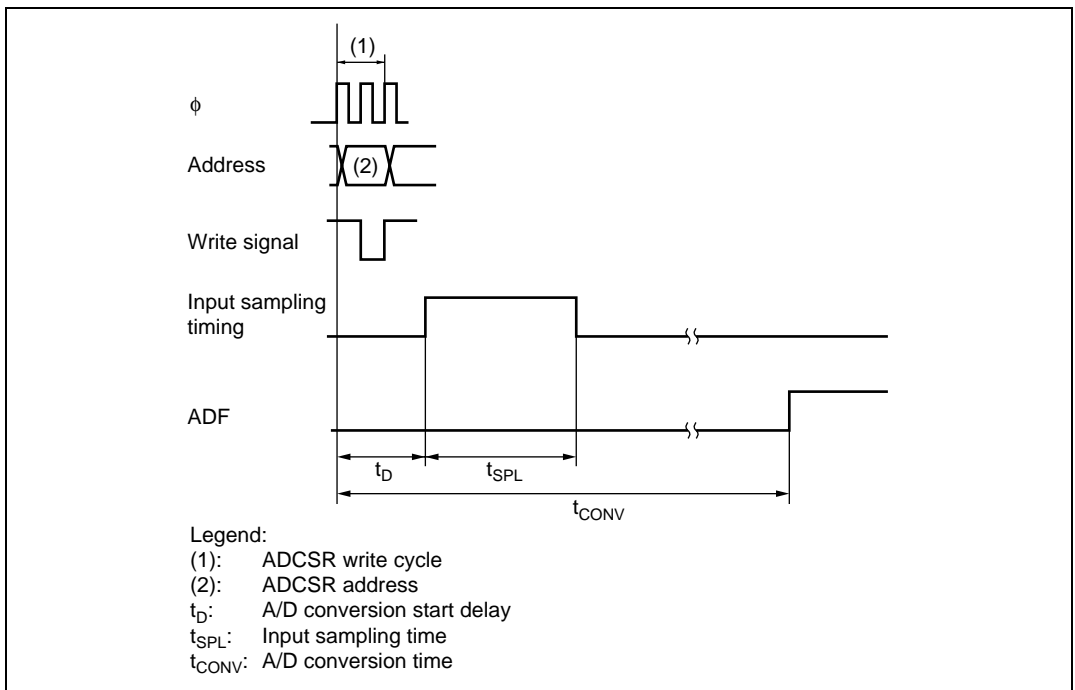

Figure 17.2 A/D Conversion Timing

Table 17.3 A/D Conversion Time (Single Mode)

Item	Symbol	CKS1 = 0						CKS1 = 1					
		CKS0 = 0			CKS0 = 1			CKS0 = 0			CKS0 = 1		
		Min	Typ	Max	Min	Typ	Max	Min	Typ	Max	Min	Typ	Max
A/D conversion start delay	t_D	18	—	33	10	—	17	6	—	9	4	—	5
Input sampling time	t_{SPL}	—	127	—	—	63	—	—	31	—	—	15	—
A/D conversion time	t_{CONV}	515	—	530	259	—	266	131	—	134	67	—	68

Note: All values represent the number of states.

Table 17.4 A/D Conversion Time (Scan Mode)

CKS1	CKS0	Conversion Time (State)
0	0	512 (Fixed)
	1	256 (Fixed)
1	0	128 (Fixed)
	1	64 (Fixed)

17.4.4 External Trigger Input Timing

A/D conversion can be externally triggered. When bits TRGS0 and TRGS1 in ADCR are set to 11, an external trigger is input on the $\overline{\text{ADTRG}}$ pin. At the falling edge of the $\overline{\text{ADTRG}}$ pin, the ADST bit in ADCSR is set to 1, and the A/D conversion starts. Other operations are the same as when the ADST bit has been set to 1 by software in both single and scan modes. Figure 17.3 shows the timing.

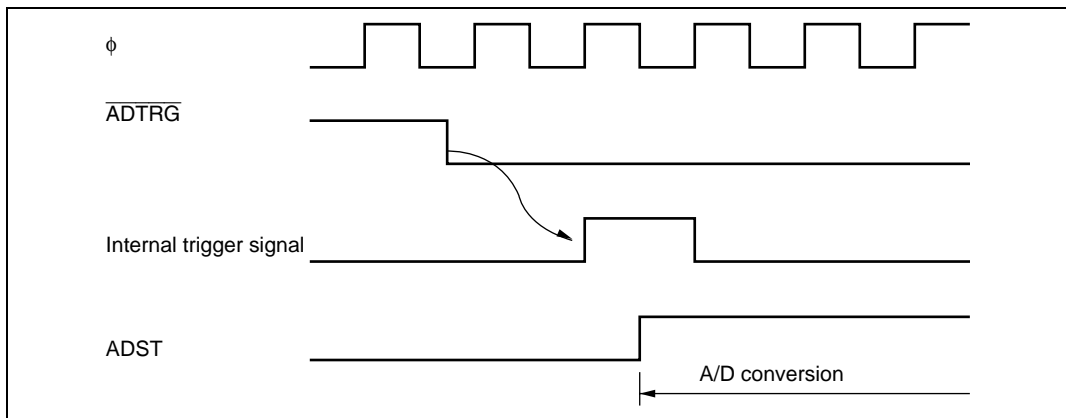

Figure 17.3 External Trigger Input Timing

17.5 Interrupt Source

When A/D conversion is completed, the A/D converter generates an A/D conversion end interrupt (ADI). The ADI interrupt request is enabled when the ADIE bit is set to 1 while the ADF bit in ADCSR is set to 1 after A/D conversion is completed. The DTC can be activated by an ADI interrupt. Having the converted data read by the DTC in response to an ADI interrupt enables continuous conversion without imposing a load on software.

Table 17.5 A/D Converter Interrupt Source

Name	Interrupt Source	Interrupt Source Flag	DTC Activation
ADI	A/D conversion completed	ADF	Possible

17.6 A/D Conversion Accuracy Definitions

This LSI's A/D conversion accuracy definitions are given below.

- Resolution
The number of A/D converter digital output codes
- Quantization error
The deviation inherent in the A/D converter, given by 1/2 LSB (see figure 17.4).
- Offset error
The deviation of the analog input voltage value from the ideal A/D conversion characteristic when the digital output changes from the minimum voltage value B'0000000000 (H'000) to B'0000000001 (H'001) (see figure 17.5).
- Full-scale error
The deviation of the analog input voltage value from the ideal A/D conversion characteristic when the digital output changes from B'1111111110 (H'3FE) to B'1111111111 (H'3FF) (see figure 17.5).
- Nonlinearity error
The error with respect to the ideal A/D conversion characteristic between zero voltage and full-scale voltage. Does not include offset error, full-scale error, or quantization error (see figure 17.5).
- Absolute accuracy
The deviation between the digital value and the analog input value. Includes offset error, full-scale error, quantization error, and nonlinearity error.

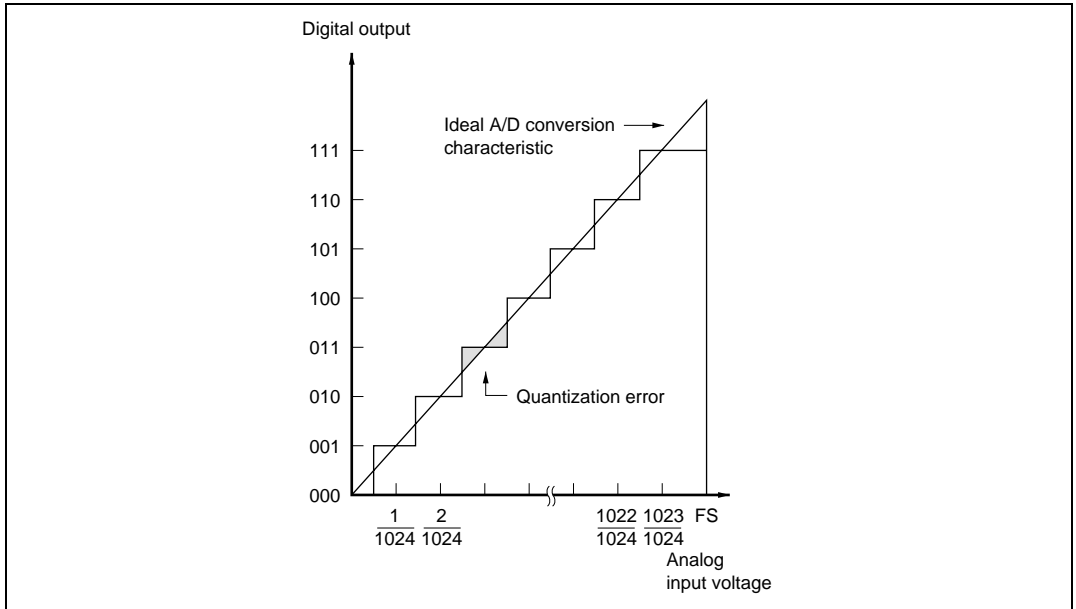

Figure 17.4 A/D Conversion Accuracy Definitions

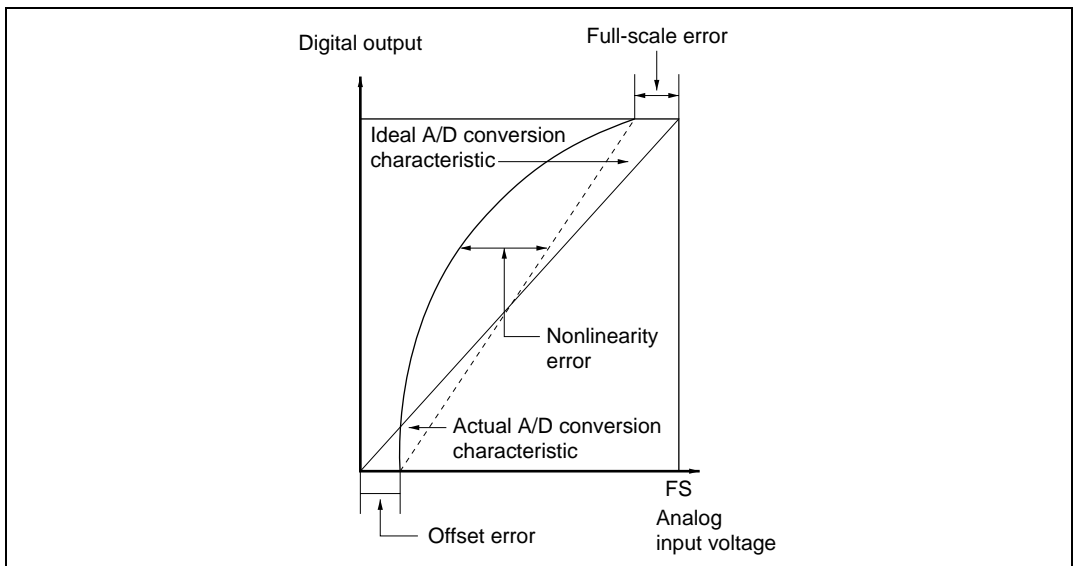

Figure 17.5 A/D Conversion Accuracy Definitions

17.7 Usage Notes

17.7.1 Module Stop Mode Setting

Operation of the A/D converter can be disabled or enabled using the module stop control register. The initial setting is for operation of the A/D converter to be halted. Register access is enabled by clearing module stop mode. For details, refer to section 21, Power-Down Modes.

17.7.2 Permissible Signal Source Impedance

This LSI's analog input is designed such that conversion accuracy is guaranteed for an input signal for which the signal source impedance is $5\text{ k}\Omega$ or less. This specification is provided to enable the A/D converter's sample-and-hold circuit input capacitance to be charged within the sampling time; if the sensor output impedance exceeds $5\text{ k}\Omega$, charging may be insufficient and it may not be possible to guarantee A/D conversion accuracy. However, for A/D conversion in single mode with a large capacitance provided externally, the input load will essentially comprise only the internal input resistance of $10\text{ k}\Omega$, and the signal source impedance is ignored. However, as a low-pass filter effect is obtained in this case, it may not be possible to follow an analog signal with a large differential coefficient (e.g., $5\text{ mV}/\mu\text{s}$ or greater) (see figure 17.6). When converting a high-speed analog signal or converting in scan mode, a low-impedance buffer should be inserted.

17.7.3 Influences on Absolute Accuracy

Adding capacitance results in coupling with GND, and therefore noise in GND may adversely affect absolute accuracy. Be sure to make the connection to an electrically stable GND such as AVSS.

Care is also required to insure that filter circuits do not communicate with digital signals on the mounting board (i.e., acting as antennas).

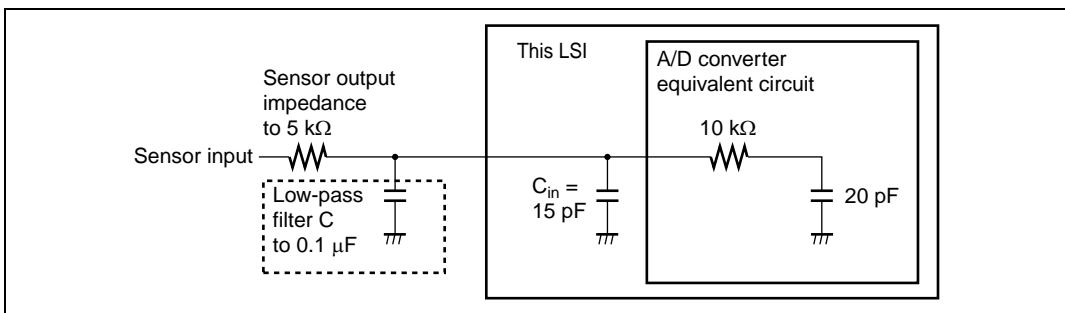

Figure 17.6 Example of Analog Input Circuit

17.7.4 Range of Analog Power Supply and Other Pin Settings

If the conditions below are not met, the reliability of the device may be adversely affected.

- Analog input voltage range
The voltage applied to analog input pin ANn during A/D conversion should be in the range $AV_{SS} \leq VN_n \leq AV_{CC}$.
- Relationship between AVcc, AVss and Vcc, Vss
Set $AV_{SS} = V_{SS}$ as the relationship between AVcc, AVss and Vcc, Vss. If the A/D converter is not used, the AVcc and AVss pins must not be left open.
- Setting range of the Vref pin
The reference voltage set by the Vref pin should be in the range $V_{ref} \leq AV_{CC}$.

17.7.5 Notes on Board Design

In board design, digital circuitry and analog circuitry should be as mutually isolated as possible, and layout in which digital circuit signal lines and analog circuit signal lines cross or are in close proximity should be avoided as far as possible. Failure to do so may result in incorrect operation of the analog circuitry due to inductance, adversely affecting A/D conversion values. Also, digital circuitry must be isolated from the analog input signals (AN15 to AN0) and analog power supply (AVcc) by the analog ground (AVss). Also, the analog ground (AVss) should be connected at one point to a stable digital ground (Vss) on the board.

17.7.6 Notes on Noise Countermeasures

A protection circuit should be connected in order to prevent damage due to abnormal voltage, such as an excessive surge at the analog input pins (AN15 to AN0), between AVcc and AVss, as shown in figure 17.7. Also, the bypass capacitors connected to AVcc and the filter capacitor connected to AN15 to AN0 must be connected to AVss.

If a filter capacitor is connected, the input currents at the analog input pins (AN15 to AN0) are averaged, and so an error may arise. Also, when A/D conversion is performed frequently, as in scan mode, if the current charged and discharged by the capacitance of the sample-and-hold circuit in the A/D converter exceeds the current input via the input impedance (R_{in}), an error will arise in the analog input pin voltage. Careful consideration is therefore required when deciding circuit constants.

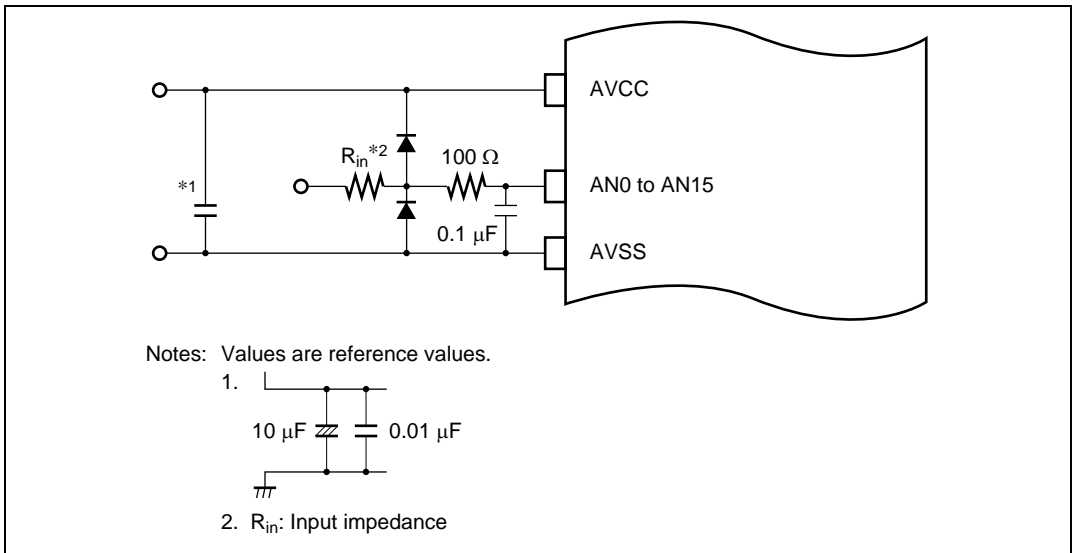

Figure 17.7 Example of Analog Input Protection Circuit

Table 17.6 Analog Pin Specifications

Item	Min	Max	Unit
Analog input capacitance	—	20	pF
Permissible signal source impedance	—	5	k Ω

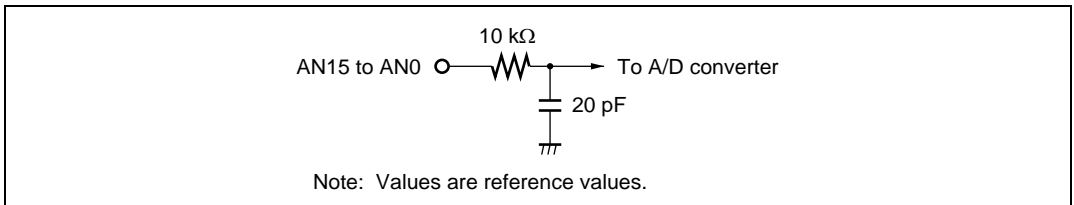

Figure 17.8 Analog Input Pin Equivalent Circuit

Section 18 RAM

The H8S/2628 has 8 kbytes, and the H8S/2627 has 6 kbytes of on-chip high-speed static RAM. The RAM is connected to the CPU by a 16-bit data bus, enabling one-state access by the CPU to both byte data and word data.

The on-chip RAM can be enabled or disabled by means of the RAME bit in the system control register (SYSCR). For details on SYSCR, refer to section 3.2.2, System Control Register (SYSCR).

Product Model		ROM Type	Capacity	Address
H8S/2628 Group	HD64F2628	Flash memory version	8 kbytes	H'FFD000 to H'FFEFBF
	HD6432628	Masked ROM version	8 kbytes	H'FFD000 to H'FFEFBF
	HD6432627		6 kbytes	H'FFD800 to H'FFEFBF

Section 19 ROM

The features of the flash memory are summarized below.

The block diagram of the flash memory is shown in figure 19.1.

19.1 Features

- Size: 128 kbytes
- Programming/erase methods
 - The flash memory is programmed 128 bytes at a time. Erase is performed in single-block units. The flash memory is configured as follows: 32 kbytes \times 2 blocks, 28 kbytes \times 1 block, 16 kbytes \times 1 block, 8 kbytes \times 2 blocks, and 1 kbyte \times 4 blocks. To erase the entire flash memory, each block must be erased in turn.
- Reprogramming capability
 - The flash memory can be reprogrammed up to 100 times.
- Three programming modes
 - Boot mode
 - User mode
 - Programmer mode
 - On-board programming/erasing can be done in boot mode, in which the boot program built into the chip is started to erase or program of the entire flash memory. In normal user program mode, individual blocks can be erased or programmed.
- Programmer mode
 - Flash memory can be programmed/erased in programmer mode using a PROM programmer, as well as in on-board programming mode.
- Automatic bit rate adjustment
 - For data transfer in boot mode, this LSI's bit rate can be automatically adjusted to match the transfer bit rate of the host.
- Programming/erasing protection
 - Sets software protection against flash memory programming/erasing.

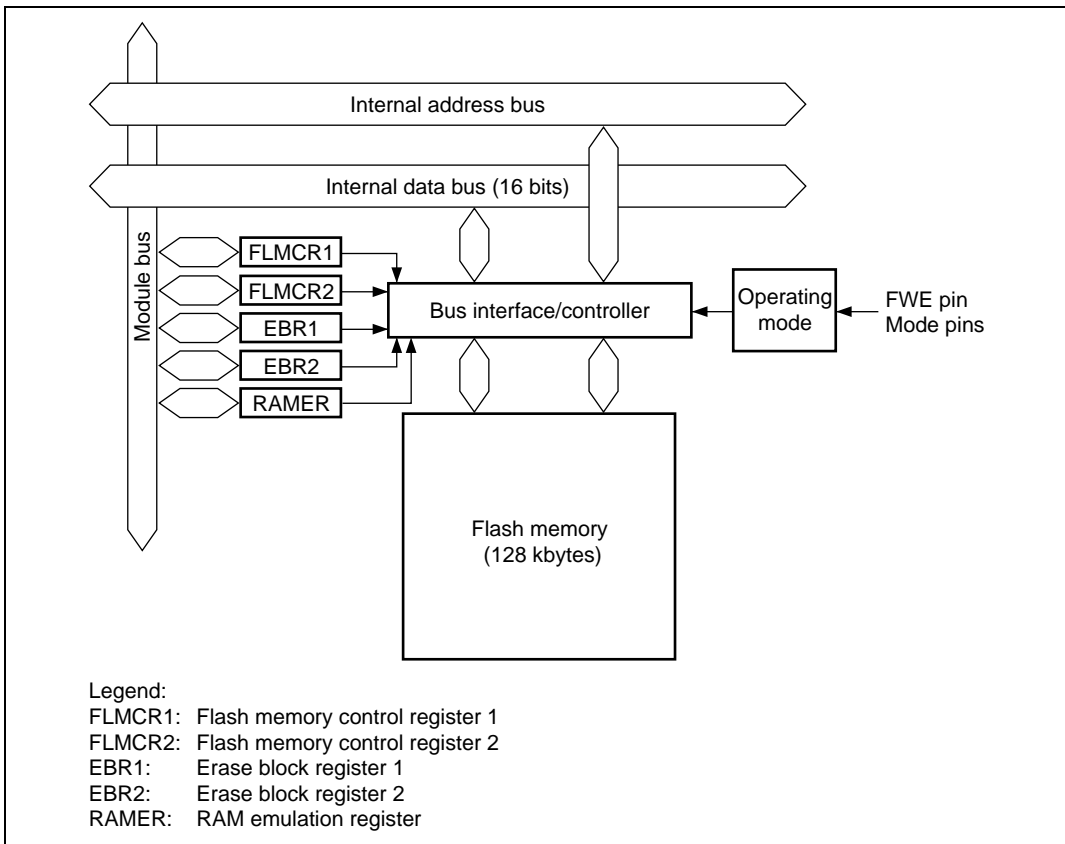

Figure 19.1 Block Diagram of Flash Memory

19.2 Mode Transitions

When the mode pins and the FWE pin are set in the reset state and a reset-start is executed, this LSI enters an operating mode as shown in figure 19.2. In user mode, flash memory can be read but not programmed or erased.

The boot, user program and programmer modes are provided as modes to write and erase the flash memory.

The differences between boot mode and user program mode are shown in table 19.1.

Figure 19.3 shows the operation flow for boot mode and figure 19.4 shows that for user program mode.

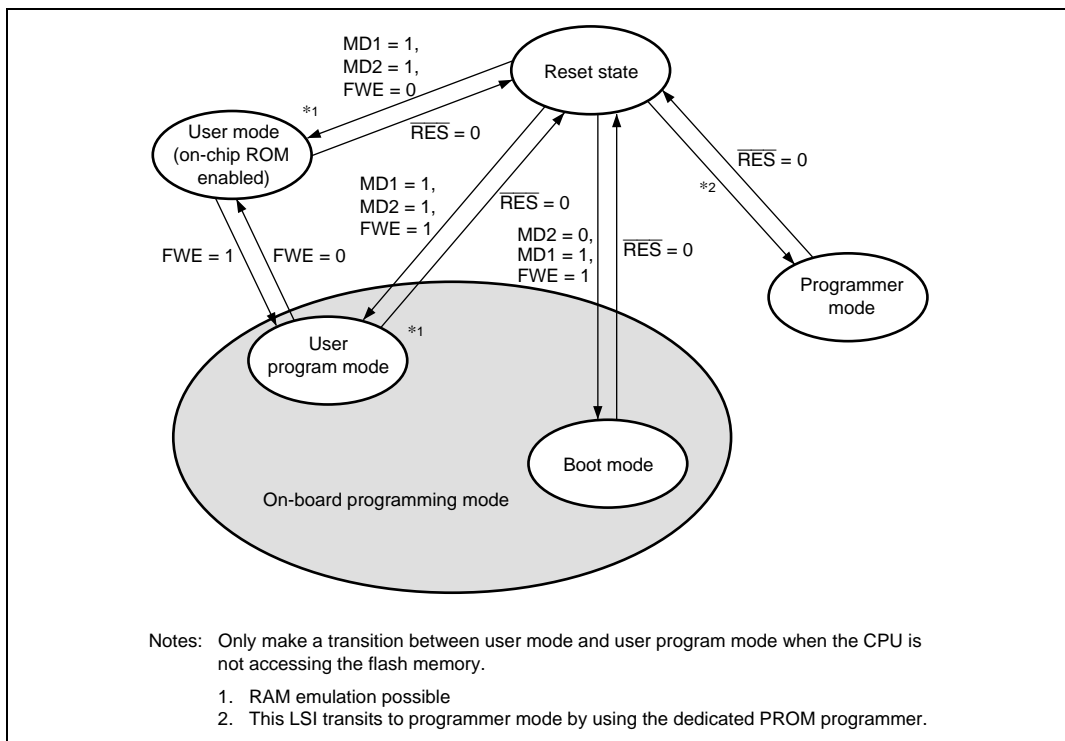

Figure 19.2 Flash Memory State Transitions

Table 19.1 Differences between Boot Mode and User Program Mode

	Boot Mode	User Program Mode
Total erase	Yes	Yes
Block erase	No	Yes
Programming control program*	(2)	(1) (2) (3)

(1) Erase/erase-verify

(2) Program/program-verify

(3) Emulation

Note: * To be provided by the user, in accordance with the recommended algorithm.

1. Initial state

The old program version or data remains written in the flash memory. The user should prepare the programming control program and new application program beforehand in the host.

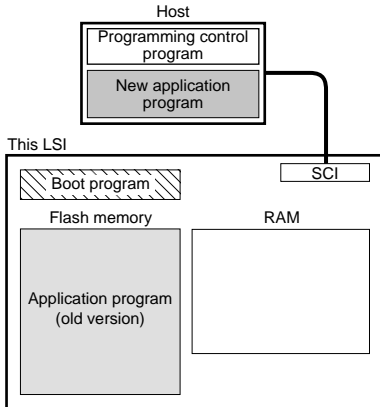

2. Programming control program transfer

When boot mode is entered, the boot program in this LSI (originally incorporated in the chip) is started and the programming control program in the host is transferred to RAM via SCI communication. The boot program required for flash memory erasing is automatically transferred to the RAM boot program area.

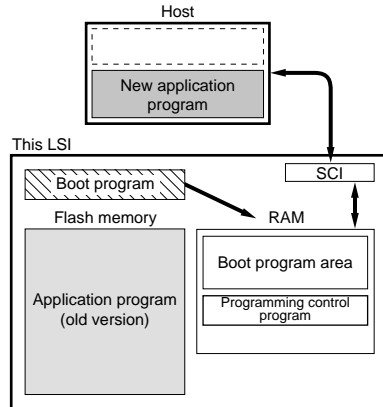

3. Flash memory initialization

The erase program in the boot program area (in RAM) is executed, and the flash memory is initialized (to H'FF). In boot mode, total flash memory erasure is performed, without regard to blocks.

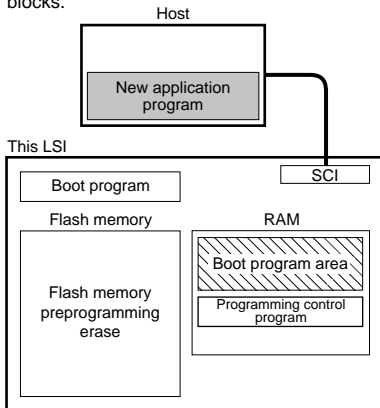

4. Writing new application program

The programming control program transferred from the host to RAM is executed, and the new application program in the host is written into the flash memory.

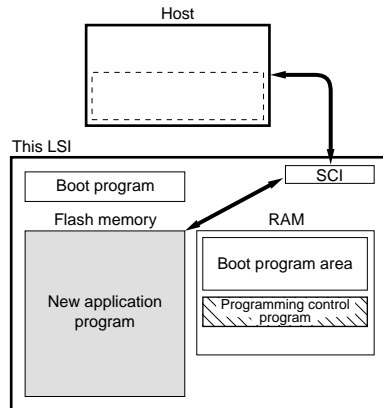

 Program execution state

Figure 19.3 Boot Mode

1. Initial state

The FWE assessment program that confirms that user program mode has been entered, and the program that will transfer the programming/erase control program from flash memory to on-chip RAM should be written into the flash memory by the user beforehand. The programming/erase control program should be prepared in the host or in the flash memory.

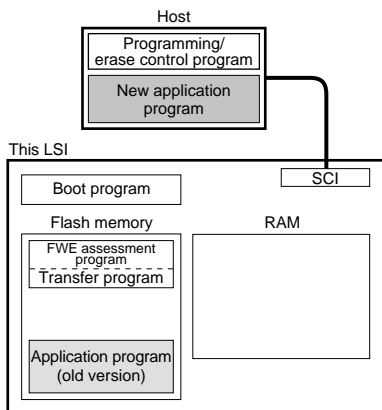

2. Programming/erase control program transfer

When user program mode is entered, user software confirms this fact, executes transfer program in the flash memory, and transfers the programming/erase control program to RAM.

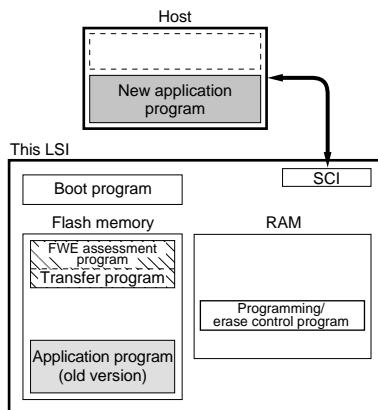

3. Flash memory initialization

The programming/erase program in RAM is executed, and the flash memory is initialized (to H'FF). Erasing can be performed in block units, but not in byte units.

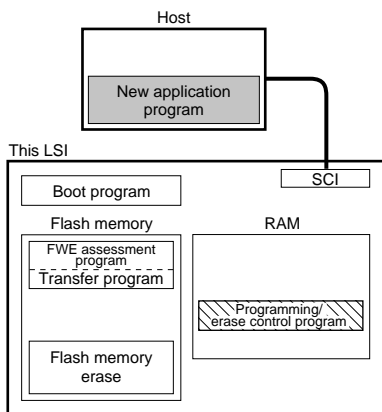

4. Writing new application program

Next, the new application program in the host is written into the erased flash memory blocks. Do not write to unerased blocks.

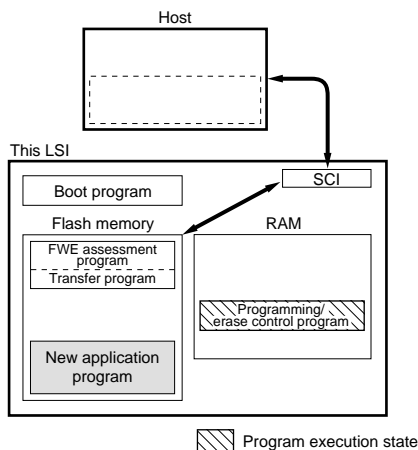

Figure 19.4 User Program Mode

19.3 Block Configuration

Figure 19.5 shows the block configuration of 128-kbyte flash memory. The thick lines indicate erasing units, the narrow lines indicate programming units, and the values are addresses. The flash memory is divided into 32 kbytes (2 blocks), 28 kbytes (1 block), 16 kbytes (1 block), 8 kbytes (2 blocks), and 1 kbyte (4 blocks). Erasing is performed in these units. Programming is performed in 128-byte units starting from an address with lower eight bits H'00 or H'80.

EB0 Erase unit 1 kbyte	H'000000	H'000001	H'000002	← Programming unit: 128 bytes →	H'00007F
	H'000380	H'000381	H'000382		H'0003FF
EB1 Erase unit 1 kbyte	H'000400	H'000401	H'000402	← Programming unit: 128 bytes →	H'00047F
	H'000780	H'000781	H'000782		H'0007FF
EB2 Erase unit 1 kbyte	H'000800	H'000801	H'000802	← Programming unit: 128 bytes →	H'00087F
	H'000B80	H'000B81	H'000B82		H'000BFF
EB3 Erase unit 1 kbyte	H'000C00	H'000C01	H'000C02	← Programming unit: 128 bytes →	H'000C7F
	H'000F80	H'000F81	H'000F82		H'000FFF
EB4 Erase unit 28 kbytes	H'001000	H'001001	H'001002	← Programming unit: 128 bytes →	H'00107F
	H'007F80	H'007F81	H'007F82		H'007FFF
EB5 Erase unit 16 kbytes	H'008000	H'008001	H'008002	← Programming unit: 128 bytes →	H'00807F
	H'00BF80	H'00BF81	H'00BF82		H'00BFFF
EB6 Erase unit 8 kbytes	H'00C000	H'00C001	H'00C002	← Programming unit: 128 bytes →	H'00C07F
	H'00DF80	H'00DF81	H'00DF82		H'00DFFF
EB7 Erase unit 8 kbytes	H'00E000	H'00E001	H'00E002	← Programming unit: 128 bytes →	H'00E07F
	H'00FF80	H'00FF81	H'00FF82		H'00FFFF
EB8 Erase unit 32 kbytes	H'010000	H'010001	H'010002	← Programming unit: 128 bytes →	H'01007F
	H'017F80	H'017F81	H'017F82		H'017FFF
EB9 Erase unit 32 kbytes	H'018000	H'018001	H'018002	← Programming unit: 128 bytes →	H'01807F
	H'01FF80	H'01FF81	H'01FF82		H'01FFFF

Figure 19.5 Flash Memory Block Configuration

19.4 Input/Output Pins

The flash memory is controlled by means of the pins shown in table 19.2.

Table 19.2 Pin Configuration

Pin Name	I/O	Function
$\overline{\text{RES}}$	Input	Reset
FWE	Input	Flash program/erase protection by hardware
MD2	Input	Sets this LSI's operating mode
MD1	Input	Sets this LSI's operating mode
MD0	Input	Sets this LSI's operating mode
TxD2	Output	Serial transmit data output
RxD2	Input	Serial receive data input

19.5 Register Descriptions

The flash memory has the following registers.

Flash memory control register 1 (FLMCR1)

Flash memory control register 2 (FLMCR2)

Erase block register 1 (EBR1)

Erase block register 2 (EBR2)

RAM emulation register (RAMER)

19.5.1 Flash Memory Control Register 1 (FLMCR1)

FLMCR1 makes the flash memory enter program mode, program-verify mode, erase mode, or erase-verify mode. For details on the register setting, refer to section 19.8, Flash Memory Programming/
Erasing.

Bit	Bit Name	Initial Value	R/W	Description
7	FWE	—	R	Reflects the input level at the FWE pin. It is set to 1 when a low level is input to the FWE pin, and cleared to 0 when a high level is input.
6	SWE	0	R/W	Software Write Enable When this bit is set to 1, flash memory programming/erasing is enabled. When this bit is cleared to 0, other FLMCR1 register bits and all EBR1 and EBR2 bits cannot be set.
5	ESU1	0	R/W	Erase Setup When this bit is set to 1, the flash memory changes to the erase setup state. When it is cleared to 0, the erase setup state is cancelled.
4	PSU1	0	R/W	Program Setup When this bit is set to 1, the flash memory changes to the program setup state. When it is cleared to 0, the program setup state is cancelled. Set this bit to 1 before setting the P1 bit in FLMCR1.
3	EV1	0	R/W	Erase-Verify When this bit is set to 1, the flash memory changes to erase-verify mode. When it is cleared to 0, erase-verify mode is cancelled.
2	PV1	0	R/W	Program-Verify When this bit is set to 1, the flash memory changes to program-verify mode. When it is cleared to 0, program-verify mode is cancelled.
1	E1	0	R/W	Erase When this bit is set to 1 while the SWE1 and ESU1 bits are 1, the flash memory changes to erase mode. When it is cleared to 0, erase mode is cancelled.
0	P1	0	R/W	Program When this bit is set to 1 while the SWE1 and PSU1 bits are 1, the flash memory changes to program mode. When it is cleared to 0, program mode is cancelled.

19.5.2 Flash Memory Control Register 2 (FLMCR2)

FLMCR2 indicates the state of flash memory programming/erasing. FLMCR2 is a read-only register, and should not be written to.

Bit	Bit Name	Initial Value	R/W	Description
7	FLER	0	R	Indicates that an error has occurred during flash memory programming or erasing. When the flash memory enters the error-protection state, this bit is set to 1. See section 19.9.3, Error Protection, for details.
6 to 0	—	All 0	—	Reserved These bits are always read as 0.

19.5.3 Erase Block Register 1 (EBR1)

EBR1 specifies the flash memory erase area block. EBR1 is initialized to H'00 when the SWE bit in FLMCR1 is 0. Do not set more than one bit at a time, otherwise, all the bits in EBR1 are automatically cleared to 0.

Bit	Bit Name	Initial Value	R/W	Description
7	EB7	0	R/W	When this bit is set to 1, 8 kbytes of EB7 (H'00E000 to H'00FFFF) will be erased.
6	EB6	0	R/W	When this bit is set to 1, 8 kbytes of EB6 (H'00C000 to H'00DFFF) will be erased.
5	EB5	0	R/W	When this bit is set to 1, 16 kbytes of EB5 (H'008000 to H'00BFFF) will be erased.
4	EB4	0	R/W	When this bit is set to 1, 28 kbytes of EB4 (H'001000 to H'007FFF) will be erased.
3	EB3	0	R/W	When this bit is set to 1, 1 kbyte of EB3 (H'000C00 to H'000FFF) will be erased.
2	EB2	0	R/W	When this bit is set to 1, 1 kbyte of EB2 (H'000800 to H'000BFF) will be erased.
1	EB1	0	R/W	When this bit is set to 1, 1 kbyte of EB1 (H'000400 to H'0007FF) will be erased.
0	EB0	0	R/W	When this bit is set to 1, 1 kbyte of EB0 (H'000000 to H'0003FF) will be erased.

19.5.4 Erase Block Register 2 (EBR2)

EBR2 specifies the flash memory erase area block. EBR1 is initialized to H'00 when the SWE bit in FLMCR1 is 0. Do not set more than one bit at a time, otherwise, all the bits in EBR1 are automatically cleared to 0.

Bit	Bit Name	Initial Value	R/W	Description
7 to 2	—	All 0	—	Reserved These bits are always read as 0.
1	EB9	0	R/W	When this bit is set to 1, 32 kbytes of EB9 (H'018000 to H'01FFFF) will be erased.
0	EB8	0	R/W	When this bit is set to 1, 32 kbytes of EB8 (H'010000 to H'017FFF) will be erased.

19.5.5 RAM Emulation Register (RAMER)

RAMER specifies the area of flash memory to be overlapped with part of RAM when emulating real-time flash memory programming. RAMER settings should be made in user mode or user program mode. To ensure correct operation of the emulation function, the ROM for which RAM emulation is performed should not be accessed immediately after this register has been modified. If accessed, normal access execution is not guaranteed.

Bit	Bit Name	Initial Value	R/W	Description
7	—	0	—	Reserved
6	—	0	—	These bits are always read as 0.
5	—	0	R/W	Reserved
4	—	0		Only 0 should be written to these bits.
3	RAMS	0	R/W	RAM Select Specifies selection or non-selection of flash memory emulation in RAM. When RAMS = 1, the flash memory is overlapped with part of RAM, and all flash memory blocks are program/erase-protected.

Bit	Bit Name	Initial Value	R/W	Description
2	RAM2	0	R/W	Flash Memory Area Selection
1	RAM1	0	R/W	Specifies one of the following flash memory areas to overlap the RAM area of H'FFE000 to H'FFE3FF when the RAMS bit is set to 1. The areas correspond with 1-kbyte erase blocks. 00x: H'000000 to H'0003FF (EB0) 01x: H'000400 to H'0007FF (EB1) 10x: H'000800 to H'000BFF (EB2) 11x: H'000C00 to H'000FFF (EB3) Legend: x: Don't care
0	RAM0	0	R/W	

19.6 On-Board Programming Modes

There are two modes for programming/erasing of the flash memory; boot mode enabling on-board programming/erasing and programmer mode enabling programming/erasing with a PROM programmer. On-board programming/erasing can also be performed in user program mode. At reset-start in reset mode, this LSI changes to a mode depending on the MD pin settings and FWE pin setting, as shown in table 19.3. The input level of each pin must be defined four states before the reset ends.

When boot mode is entered, the boot program built into this LSI is initiated. The boot program transfers the programming control program from the externally-connected host to on-chip RAM via SCI_2. After erasing the entire flash memory, the programming control program is executed. This can be used for programming initial values in the on-board state or for a forcible return in case that programming/erasing cannot be performed in user program mode. In user program mode, individual blocks can be erased and programmed by branching to the user program/erase control program prepared by the user.

Table 19.3 Setting On-Board Programming Modes

MD2	MD1	MD0	FWE	LSI State after Reset End
1	1	1	1	User Mode
0	1	1	1	Boot Mode

19.6.1 Boot Mode

Table 19.4 shows the boot mode operations from a reset end to a branch to the programming control program.

1. In boot mode, the flash memory programming control program must be prepared in the host beforehand. Prepare a programming control program in accordance with the description in section 19.8, Flash Memory Programming/Erasing.
2. SCI_2 should be set to asynchronous mode with the transfer format of 8-bit data, 1 stop bit, and no parity.
3. When the boot program is initiated, the chip measures the low-level period of asynchronous SCI communication data (H'00) transmitted continuously from the host. The chip then calculates the bit rate of transmission from the host, and adjusts the SCI_2 bit rate to match that of the host. The reset should end with the RxD pin high. The RxD and TxD pins should be pulled up on the board if necessary. After the reset is complete, it takes approximately 100 states before the chip is ready to measure the low-level period.
4. When the bit rate matching is completed, the chip transmits 1-byte data H'00 to the host to indicate the end of bit rate adjustment. The host should confirm that this adjustment end indication (H'00) has been received normally, and transmit 1-byte data H'55 to the chip. If reception could not be performed normally, initiate boot mode again by a reset. Depending on the host's transfer bit rate and system clock frequency of this LSI, there will be a discrepancy between the bit rates of the host and the chip. To operate the SCI properly, set the host's transfer bit rate and system clock frequency of this LSI within the ranges listed in table 19.5.
5. In boot mode, a part of the on-chip RAM area is used by the boot program. The area H'FFE800 to H'FFEFBF is used to store the programming control program to be transferred from the host. The boot program area cannot be used until the execution is shifted to the programming control program.
6. Before branching to the programming control program, the chip terminates transfer operations by SCI_2 (by clearing the RE and TE bits in SCR to 0), however the adjusted bit rate value is retained in BRR. Therefore, the programming control program can still use it for transfer of write data or verify data with the host. At this time, the TxD pin is in the high level output state. The contents of the CPU general registers are undefined immediately after branching to the programming control program. These registers must be initialized at the beginning of the programming control program, since the stack pointer (SP), in particular, is used implicitly in subroutine calls, etc.
7. Boot mode can be cleared by a reset. End the reset by driving the reset pin low, waiting at least 20 states, and then setting the mode (MD) pins. Boot mode is also cleared when a WDT overflow occurs.
8. Do not change the MD pin input level in boot mode.

9. All interrupts are disabled during programming or erasing of the flash memory.

Table 19.4 Boot Mode Operation

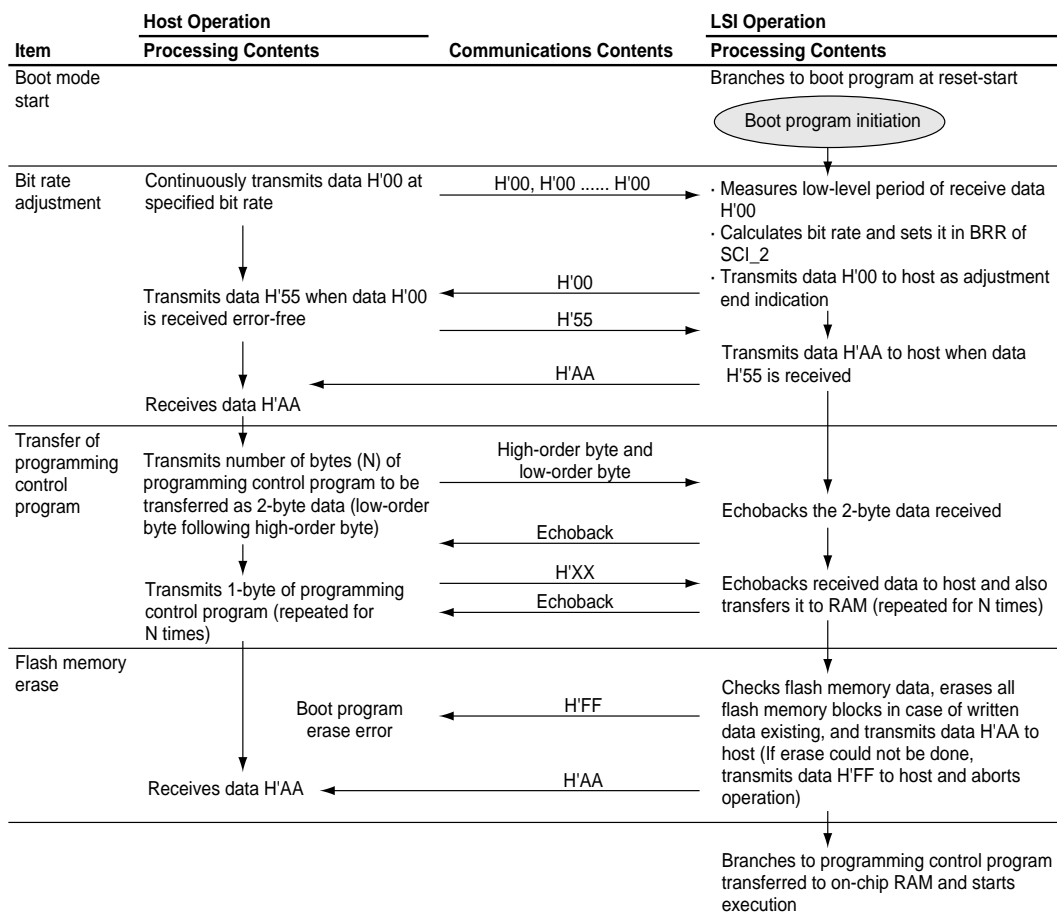

Table 19.5 System Clock Frequencies for which Automatic Adjustment of LSI Bit Rate is Possible

Host Bit Rate	System Clock Frequency Range of LSI
19,200 bps	24 MHz
9,600 bps	24 to 8 MHz
4,800 bps	24 to 4 MHz

19.6.2 Programming/Erasing in User Program Mode

On-board programming/erasing of an individual flash memory block can also be performed in user program mode by branching to a user program/erase control program. The user must set branching conditions and provide on-board means of supplying programming data. The flash memory must contain the user program/erase control program or a program that provides the user program/erase control program from external memory. Since the flash memory itself cannot be read during programming/erasing, transfer the user program/erase control program to on-chip RAM, as in boot mode. Figure 19.6 shows a sample procedure for programming/erasing in user program mode. Prepare a user program/erase control program in accordance with the description in section 19.8, Flash Memory Programming/Erasing.

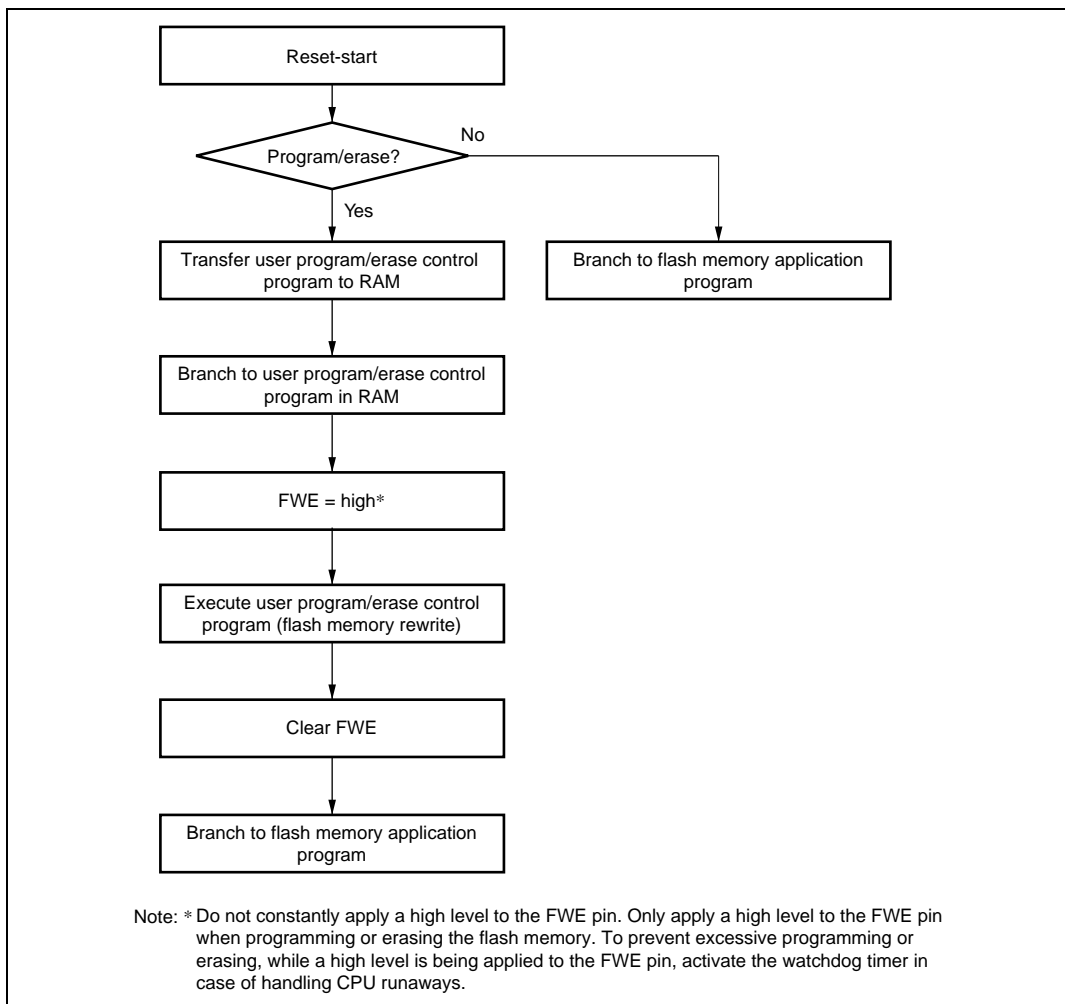

Figure 19.6 Programming/Erasing Flowchart Example in User Program Mode

19.7 Flash Memory Emulation in RAM

A setting in the RAM emulation register (RAMER) enables part of RAM to be overlapped onto the flash memory area so that data to be written to flash memory can be emulated in RAM in real time. Emulation can be performed in user mode or user program mode. Figure 19.7 shows an example of emulation of real-time flash memory programming.

1. Set RAMER to overlap part of RAM onto the area for which real-time programming is required.
2. Emulation is performed using the overlapping RAM.
3. After the program data has been confirmed, the RAMS bit is cleared, thus releasing the RAM overlap.
4. The data written in the overlapping RAM is written into the flash memory space (EB0).

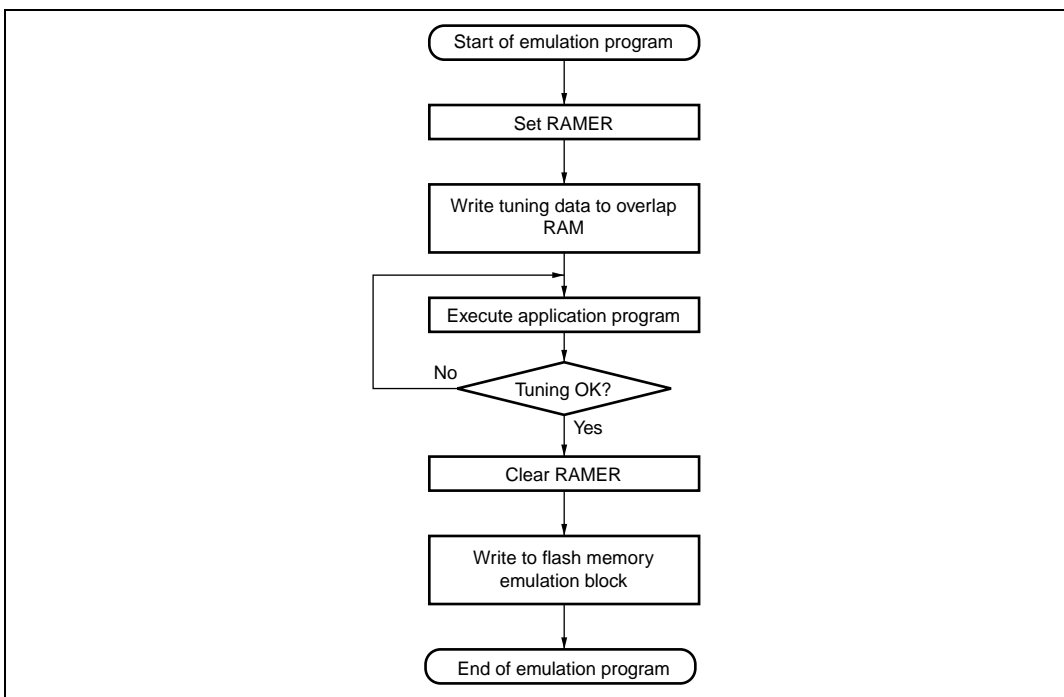

Figure 19.7 Flowchart for Flash Memory Emulation in RAM

An example in which flash memory block area EB0 is overlapped is shown in figure 19.8.

1. The RAM area to be overlapped is fixed at a 1-kbyte area in the range H'FFE000 to H'FFE3FF.
2. The flash memory area to overlap is selected by RAMER from a 1-kbyte area of the EB0 to EB3 blocks.
3. The overlapped RAM area can be accessed from both the flash memory addresses and RAM addresses.
4. When the RAMS bit in RAMER is set to 1, program/erase protection is enabled for all flash memory blocks (emulation protection). In this state, setting the P1 or E1 bit in FLMCR1 to 1 does not make a transition to program mode or erase mode.
5. A RAM area cannot be erased by execution of software in accordance with the erase algorithm.
6. Block area EB0 contains the vector table. When performing RAM emulation, the vector table is needed in the overlap RAM.

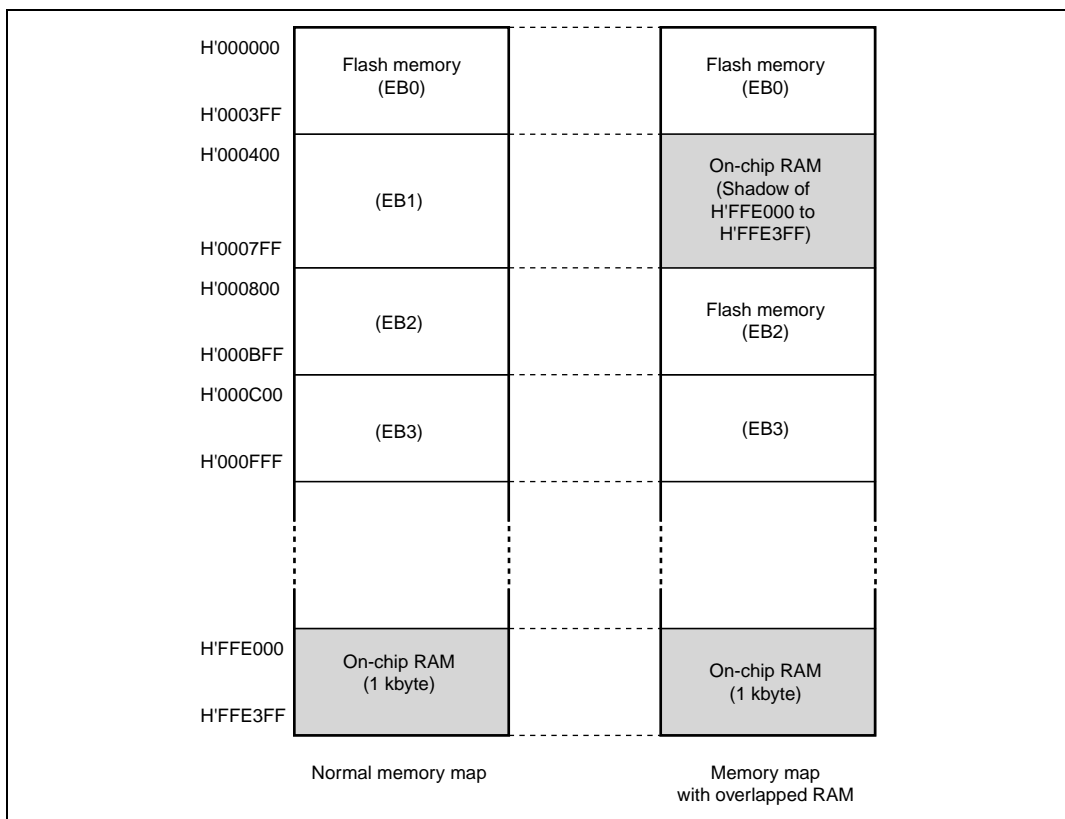

Figure 19.8 Example of RAM Overlap Operation

19.8 Flash Memory Programming/Erasing

The flash memory is programmed or erased in on-board programming mode by a software method using the CPU. Depending on the FLMCR1 setting, the flash memory operates in one of the following four modes: Program mode, program-verify mode, erase mode, and erase-verify mode. The programming control program in boot mode and the user program/erase control program in user program mode perform programming/erasing in combination with these modes. Flash memory programming and erasing should be performed in accordance with the descriptions in section 19.8.1, Program/Program-Verify, and section 19.8.2, Erase/Erase-Verify, respectively.

19.8.1 Program/Program-Verify

When writing data or programs to the flash memory, the program/program-verify flowchart shown in figure 19.9 should be followed. Performing programming operations according to this flowchart will enable data or programs to be written to the flash memory without subjecting the chip to voltage stress or sacrificing program data reliability.

1. Programming must be done on erased addresses. Do not perform additional programming or previously programmed addresses.
2. Programming should be performed in units of 128 bytes. A 128-byte data must be transferred even if data to be written is fewer than 128 bytes. In this case, H'FF data must be written to the extra addresses.
3. Prepare the following data storage areas in RAM: A 128-byte programming data area, a 128-byte reprogramming data area, and a 128-byte additional-programming data area. Perform reprogramming data computation and additional programming data computation according to figure 19.9.
4. Consecutively transfer 128 bytes of data in byte units from the reprogramming data area or additional-programming data area to the flash memory. The program address and 128-byte data are latched in the flash memory. The lower 8 bits of the start address in the flash memory destination area must be H'00 or H'80.
5. The time during which the P1 bit is set to 1 is the programming time. Figure 19.9 shows the allowable programming times.
6. The watchdog timer (WDT) is set to prevent overprogramming due to program runaway, etc. Set the overflow cycle to approximately 6.6 ms.
7. For a dummy write to a verify address, write 1-byte data H'FF to an address whose lower 2 bits are B'00. Verify data can be read in longwords from the address to which a dummy write was performed.
8. The number of repetitions of the program/program-verify sequence for the same bit should be less than 1,000.

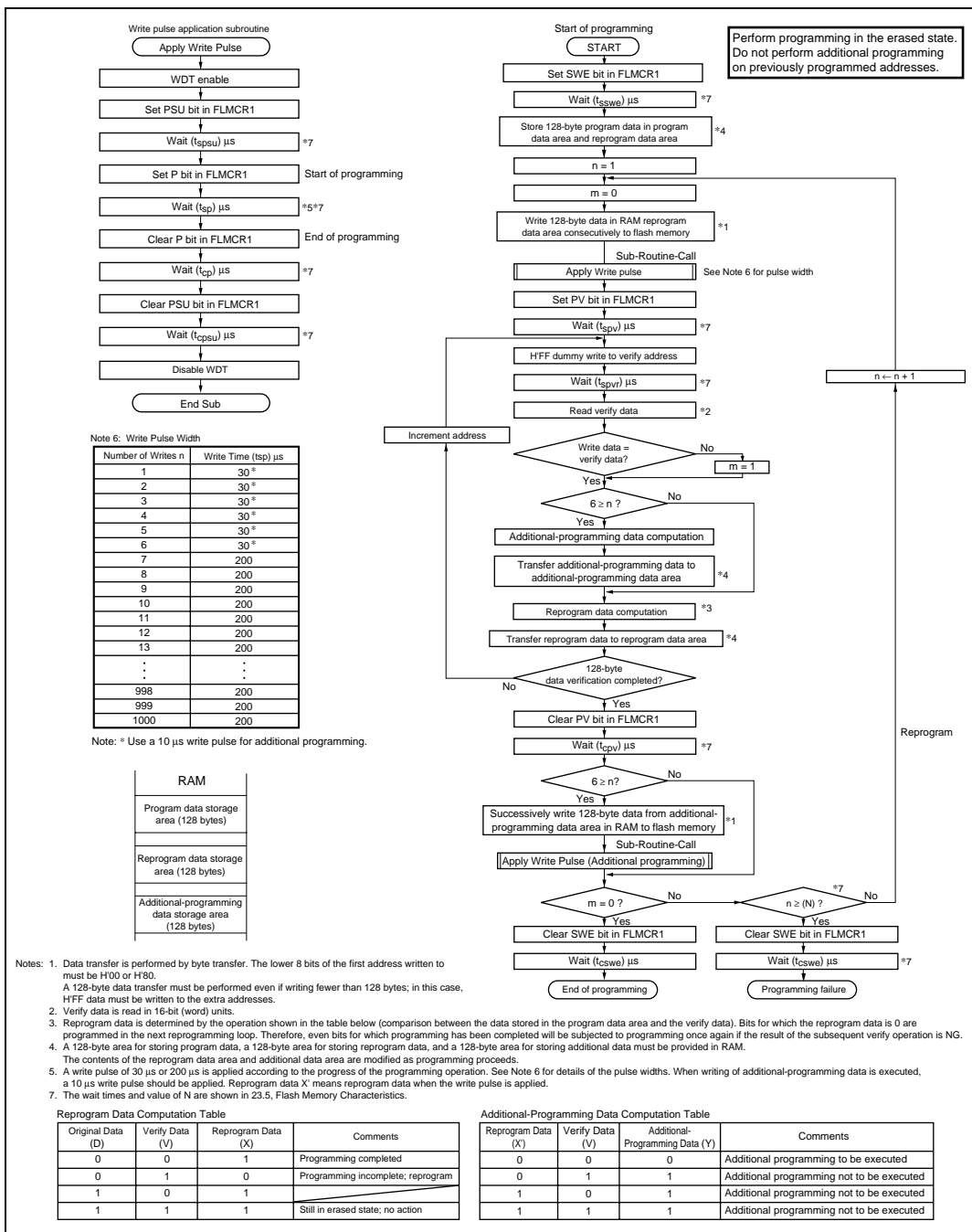

Figure 19.9 Program/Program-Verify Flowchart

19.8.2 Erase/Erase-Verify

When erasing flash memory, the erase/erase-verify flowchart shown in figure 19.10 should be followed.

1. Prewriting (setting erase block data to all 0s) is not necessary.
2. Erasing is performed in block units. Specify a single block to be erased with the erase block registers (EBR2 and EBR1). To erase multiple blocks, each block must be erased in turn.
3. The time during which the E bit is set to 1 is the flash memory erase time.
4. The watchdog timer (WDT) is set to prevent overerasing due to program runaway, etc. Set the overflow cycle to approximately 19.8 ms.
5. For a dummy write to a verify address, write 1-byte data H'FF to an address whose lower two bits are B'00. Verify data can be read in longwords from the address to which a dummy write was performed.
6. If the read data is not erased successfully, set erase mode again, and repeat the erase/erase-verify sequence as before. Note that the number of repetitions of the erase/erase-verify sequence should be less than 100.

19.8.3 Interrupt Handling when Programming/Erasing Flash Memory

All interrupts, including the $\overline{\text{NMI}}$ interrupt, should be disabled while flash memory is being programmed, erased, or the boot program is being executed, for the following three reasons:

1. Interrupt during programming/erasing may cause a violation of the programming or erasing algorithm, with the result that normal operation cannot be assured.
2. If interrupt exception handling starts before the vector address is written or during programming/erasing, a correct vector cannot be fetched and the CPU malfunctions.
3. If an interrupt occurs during boot program execution, normal boot mode sequence cannot be carried out.

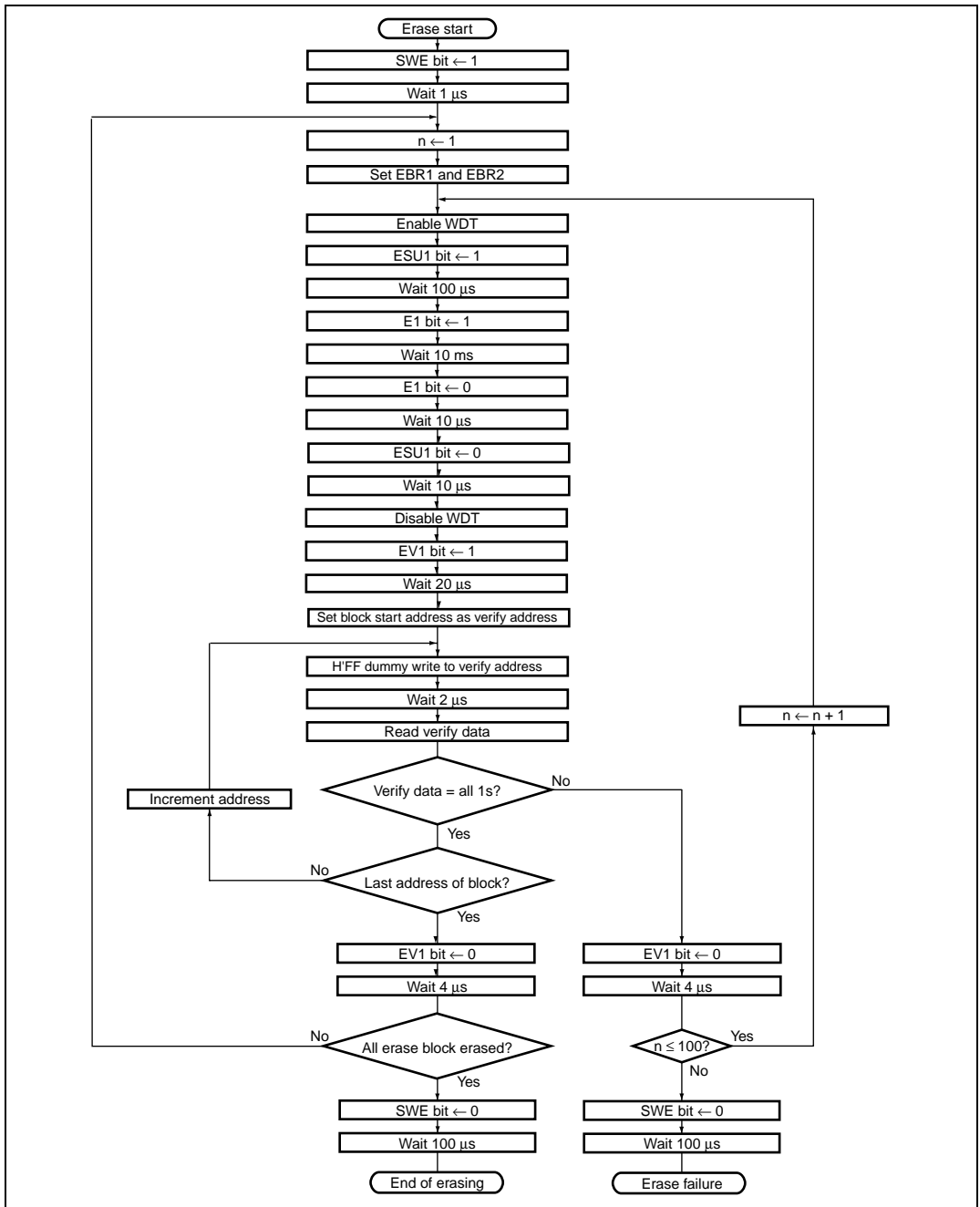

Figure 19.10 Erase/Eraser-Verify Flowchart

19.9 Program/Erase Protection

There are three kinds of flash memory program/erase protection; hardware protection, software protection, and error protection.

19.9.1 Hardware Protection

Hardware protection refers to a state in which programming/erasing of flash memory is forcibly disabled or aborted because of a transition to reset or standby mode. Flash memory control register 1 (FLMCR1), flash memory control register 2 (FLMCR2), and erase block register 1 (EBR1) are initialized. In a reset via the $\overline{\text{RES}}$ pin, the reset state is not entered unless the $\overline{\text{RES}}$ pin is held low until oscillation settles after powering on. In the case of a reset during operation, hold the $\overline{\text{RES}}$ pin low for the $\overline{\text{RES}}$ pulse width specified in the AC characteristics section.

19.9.2 Software Protection

Software protection can be implemented against programming/erasing of all flash memory blocks by clearing the SWE bit in FLMCR1. When software protection is in effect, setting the P1 or E1 bit in FLMCR1 does not cause a transition to program mode or erase mode. By setting the erase block register 1 (EBR1), erase protection can be set for individual blocks. When EBR1 is set to H'00, erase protection is set for all blocks.

19.9.3 Error Protection

In error protection, an error is detected when CPU runaway occurs during flash memory programming/erasing, or operation is not performed in accordance with the program/erase algorithm, and the program/erase operation is aborted. Aborting the program/erase operation prevents damage to the flash memory due to overprogramming or overerasing.

When the following errors are detected during programming/erasing of flash memory, the FLER bit in FLMCR2 is set to 1, and the error protection state is entered.

- When the flash memory of the relevant address area is read during programming/erasing (including vector read and instruction fetch)
- Immediately after exception handling (excluding a reset) during programming/erasing
- When a SLEEP instruction is executed during programming/erasing

The FLMCR2, FLMCR1, and EBR1 settings are retained, however program mode or erase mode is aborted at the point at which the error occurred. Program mode or erase mode cannot be re-

entered by re-setting the P1 or E1 bit. However, PV1 and EV1 bit setting is enabled, and a transition can be made to verify mode. Error protection can be cleared only by a power-on reset.

19.10 Programmer Mode

In programmer mode, a PROM programmer can be used to perform programming/erasing via a socket adapter, just as for a discrete flash memory. Use a PROM programmer that supports the Renesas 128-kbyte flash memory on-chip MCU device type (FZTAT128V5A).

19.11 Power-Down States for Flash Memory

In user mode, the flash memory will operate in either of the following states:

- Normal operating mode
The flash memory can be read and written to.
- Standby mode
All flash memory circuits are halted.

Table 19.6 shows the correspondence between the operating modes of the H8S/2628 Group and the flash memory. When the flash memory returns to its normal operating state from standby mode, a period to settle the power supply circuits that were stopped is needed. When the flash memory returns to its normal operating state, bits STS2 to STS0 in SBYCR must be set to provide a wait time of at least 20 μ s, even when the external clock is being used.

Table 19.6 Flash Memory Operating States

LSI Operating State	Flash Memory Operating State
Active mode	Normal operating mode
Standby mode	Standby mode

19.12 Note on Switching from F-ZTAT Version to Masked ROM Version

The masked ROM version does not have the internal registers for flash memory control that are provided in the F-ZTAT version. Table 19.7 lists the registers that are present in the F-ZTAT version but not in the masked ROM version. If a register listed in table 19.7 is read in the masked ROM version, an undefined value will be returned. Therefore, if application software developed on the F-ZTAT version is switched to a masked ROM version product, it must be modified to ensure that the registers in table 19.7 have no effect.

Table 19.7 Registers Present in F-ZTAT Version but Absent in Masked ROM Version

Register	Abbreviation	Address
Flash memory control register 1	FLMCR1	H'FFA8
Flash memory control register 2	FLMCR2	H'FFA9
Erase block register 1	EBR1	H'FFAA
Erase block register 2	EBR2	H'FFAB
RAM emulation register	RAMER	H'FEDB

Section 20 Clock Pulse Generator

This LSI has an on-chip clock pulse generator that generates the system clock (ϕ), the bus master clock, and internal clocks. The clock pulse generator consists of an oscillator, PLL circuit, clock selection circuit, medium-speed clock divider, and bus master clock selection circuit. A block diagram of the clock pulse generator is shown in figure 20.1.

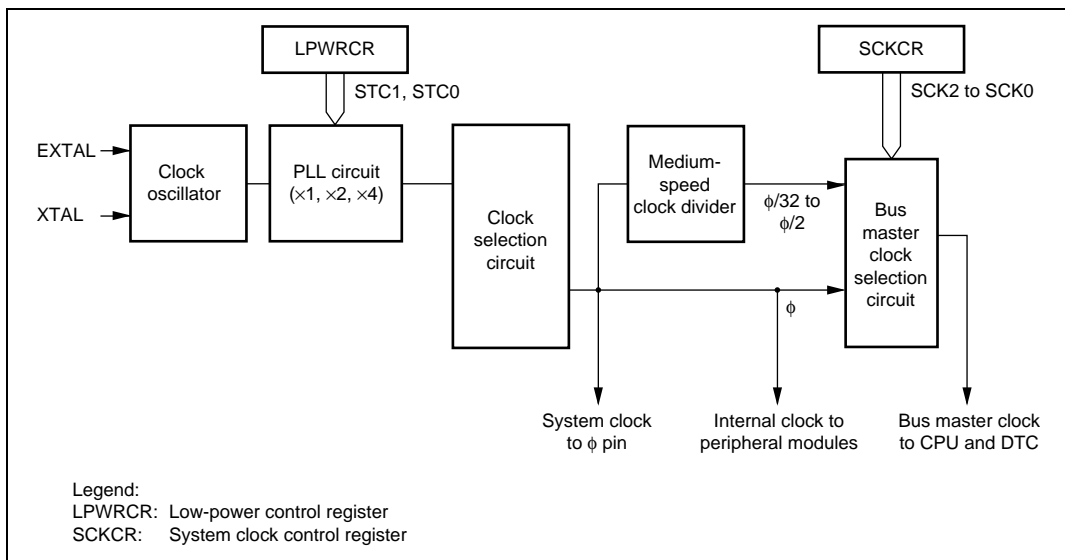

Figure 20.1 Block Diagram of Clock Pulse Generator

The frequency can be changed by means of the PLL circuit. Frequency changes are performed by software by settings in the low-power control register (LPWRCR) and system clock control register (SCKCR).

20.1 Register Descriptions

The on-chip clock pulse generator has the following registers.

- System clock control register (SCKCR)
- Low-power control register (LPWRCCR)

20.1.1 System Clock Control Register (SCKCR)

SCKCR performs ϕ clock output control, selection of operation when the PLL circuit frequency multiplication factor is changed, and medium-speed mode control.

Bit	Bit Name	Initial Value	R/W	Description
7	PSTOP	0	R/W	ϕ Clock Output Disable Controls ϕ output. High-speed Mode, Medium-Speed Mode 0: ϕ output 1: Fixed high Sleep Mode 0: ϕ output 1: Fixed high Software Standby Mode 0: Fixed high 1: Fixed high Hardware Standby Mode 0: High impedance 1: High impedance
6 to 4	—	All 0	—	Reserved These bits are always read as 0.
3	STCS	0	R/W	Frequency Multiplication Factor Switching Mode Select Selects the operation when the PLL circuit frequency multiplication factor is changed. 0: Specified multiplication factor is valid after transition to software standby mode 1: Specified multiplication factor is valid immediately after STC1 bit and STC0 bit are rewritten

Bit	Bit Name	Initial Value	R/W	Description
2	SCK2	0	R/W	System Clock Select 2 to 0
1	SCK1	0	R/W	These bits select the bus master clock.
0	SCK0	0	R/W	000: High-speed mode 001: Medium-speed clock is $\phi/2$ 010: Medium-speed clock is $\phi/4$ 011: Medium-speed clock is $\phi/8$ 100: Medium-speed clock is $\phi/16$ 101: Medium-speed clock is $\phi/32$ 11x: Setting prohibited

Legend:

x: Don't care

20.1.2 Low-Power Control Register (LPWRCR)

Bit	Bit Name	Initial Value	R/W	Description
7 to 4	—	All 0	—	Reserved The write value should always be 0.
3, 2	—	All 0	R/W	Reserved These bits can be read from and write to, but should not be set to 1.
1	STC1	0	R/W	Frequency Multiplication Factor
0	STC0	0	R/W	The STC bits specify the frequency multiplication factor of the PLL circuit. 00: $\times 1$ 01: $\times 2$ 10: $\times 4$ 11: Setting prohibited

20.2 Oscillator

Clock pulses can be supplied by connecting a crystal resonator, or by input of an external clock. In either case, the input clock should not exceed 24 MHz.

20.2.1 Connecting a Crystal Resonator

Circuit Configuration: A crystal resonator can be connected as shown in the example in figure 20.2. Select the damping resistance R_d according to table 20.1. An AT-cut parallel-resonance crystal should be used.

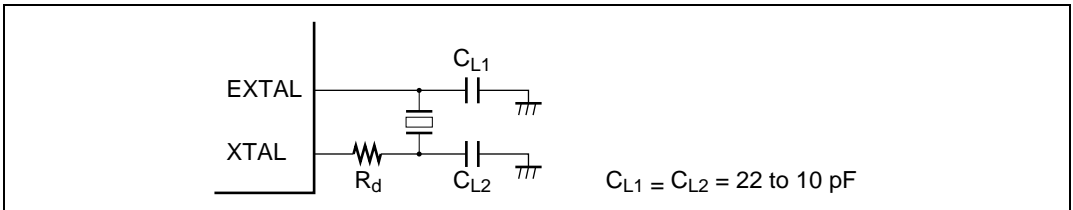

Figure 20.2 Connection of Crystal Resonator (Example)

Table 20.1 Damping Resistance Value

Frequency (MHz)	4	8	10	12	16	20	24
R_d (Ω)	500	200	0	0	0	0	0

Figure 20.3 shows the equivalent circuit of the crystal resonator. Use a crystal resonator that has the characteristics shown in table 20.2.

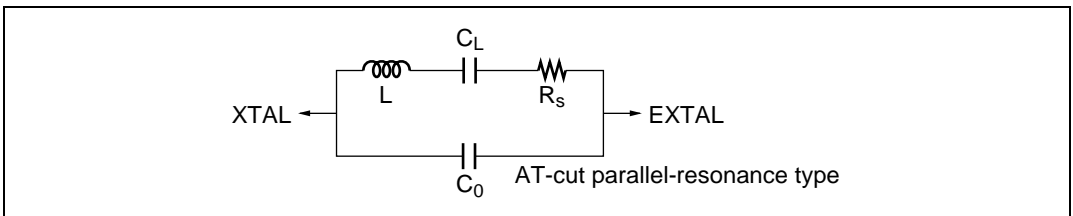

Figure 20.3 Crystal Resonator Equivalent Circuit

Table 20.2 Crystal Resonator Characteristics

Frequency (MHz)	4	8	10	12	16	20	24
R_S max (Ω)	120	80	70	60	50	40	30
C_0 max (pF)	7	7	7	7	7	7	7

20.2.2 External Clock Input

Circuit Configuration: An external clock signal can be input as shown in the examples in figure 20.4. If the XTAL pin is left open, ensure that stray capacitance does not exceed 10 pF. When complementary clock is input to the XTAL pin, the external clock input should be fixed high in standby mode.

**Figure 20.4 External Clock Input (Examples)**

Table 20.3 shows the input conditions for the external clock.

Table 20.3 External Clock Input Conditions

Item	Symbol	$V_{CC} = 5.0\text{ V} \pm 10\%$		Unit	Test Conditions
		Min	Max		
External clock input low pulse width	t_{EXL}	15	—	ns	Figure 20.5
External clock input high pulse width	t_{EXH}	15	—	ns	
External clock rise time	t_{EXr}	—	5	ns	
External clock fall time	t_{EXf}	—	5	ns	

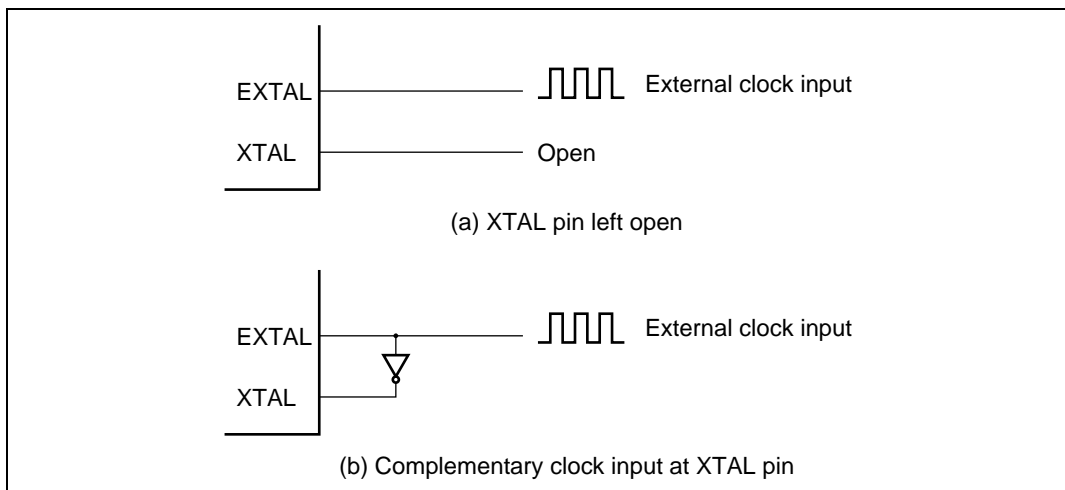
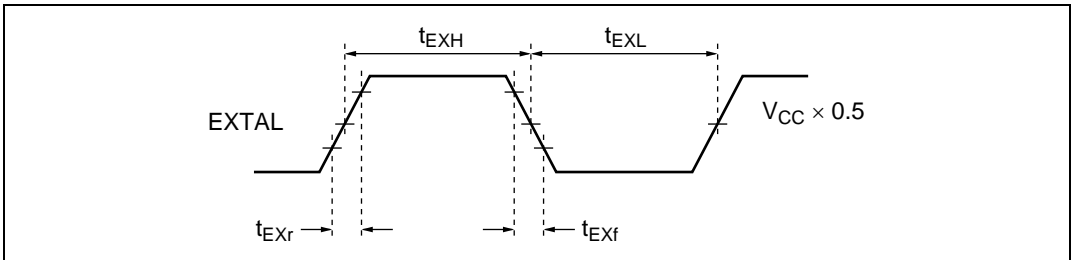

Figure 20.5 External Clock Input Timing

20.3 PLL Circuit

The PLL circuit multiplies the frequency of the clock from the oscillator by a factor of 1, 2, or 4. The multiplication factor is set by the STC0 bit and the STC1 bit in LPWRCR. The phase of the rising edge of the internal clock is controlled so as to match that at the EXTAL pin.

When the multiplication factor of the PLL circuit is changed, the operation varies according to the setting of the STCS bit in SCKCR.

When STCS = 0, the setting becomes valid after a transition to software standby mode. The transition time count is performed in accordance with the setting of bits STS2 to STS0 in SBYCR. For details on SBYCR, refer to section 21.1.1, Standby Control Register (SBYCR).

1. The initial PLL circuit multiplication factor is 1.
2. STS2 to STS0 are set to give the specified transition time.
3. The target value is set in STC1 and STC0, and a transition is made to software standby mode.
4. The clock pulse generator stops and the value set in STC1 and STC0 becomes valid.
5. Software standby mode is cleared, and a transition time is secured in accordance with the setting in STS2 to STS0.
6. After the set transition time has elapsed, this LSI resumes operation using the target multiplication factor.

If a PC break is set for the SLEEP instruction, software standby mode is entered and break exception handling is executed after the oscillation settling time. In this case, the instruction following the SLEEP instruction is executed after execution of the RTE instruction. When STCS = 1, this LSI operates on the changed multiplication factor immediately after bits STC1 and STC0 are rewritten.

20.4 Medium-Speed Clock Divider

The medium-speed clock divider divides the system clock to generate $\phi/2$, $\phi/4$, $\phi/8$, $\phi/16$, and $\phi/32$.

20.5 Bus Master Clock Selection Circuit

The bus master clock selection circuit selects the clock supplied to the bus master by setting the bits SCK2 to SCK0 in SCKCR. The bus master clock can be selected from high-speed mode, or medium-speed clocks ($\phi/2$, $\phi/4$, $\phi/8$, $\phi/16$, $\phi/32$).

20.6 Usage Notes

20.6.1 Note on Crystal Resonator

As various characteristics related to the crystal resonator are closely linked to the user's board design, thorough evaluation is necessary on the user's part, using the resonator connection examples shown in this section as a guide. As the resonator circuit ratings will depend on the floating capacitance of the resonator and the mounting circuit, the ratings should be determined in consultation with the resonator manufacturer. The design must ensure that a voltage exceeding the maximum rating is not applied to the oscillator pin.

20.6.2 Note on Board Design

When designing the board, place the crystal resonator and its load capacitors as close as possible to the XTAL and EXTAL pins. Other signal lines should be routed away from the oscillator circuit, as shown in figure 20.6. This is to prevent induction from interfering with correct oscillation.

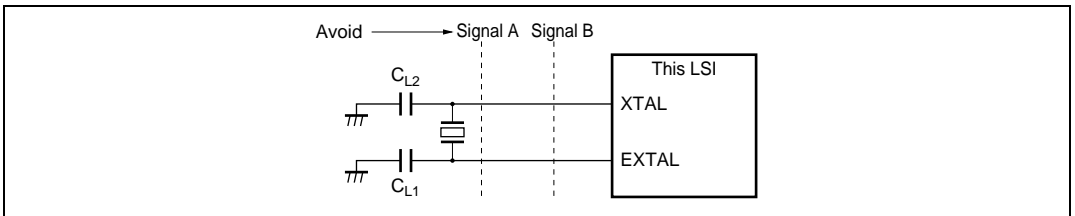
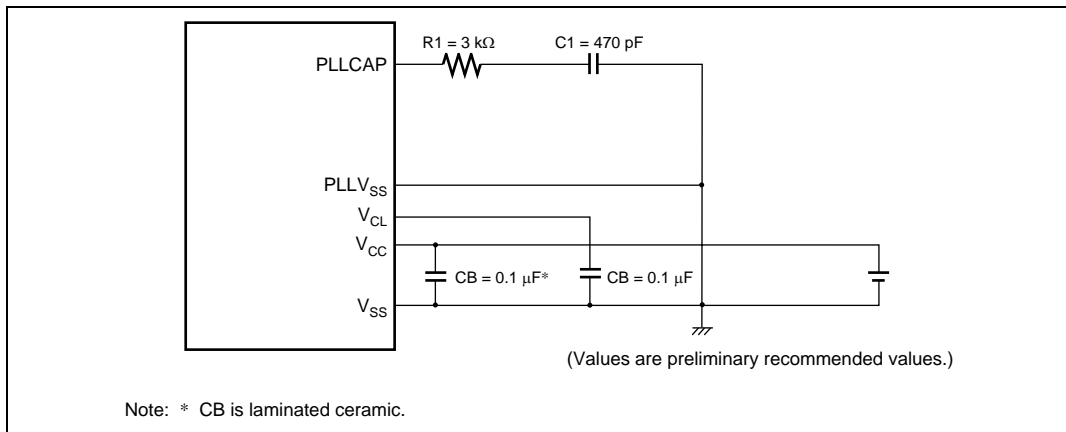

Figure 20.6 Note on Board Design of Oscillator Circuit

Figure 20.7 shows external circuitry recommended to be provided around the PLL circuit. Place oscillation settling capacitor C1 and resistor R1 close to the PLLCAP pin, and ensure that no other signal lines cross this line. Separate PLLVss from the other Vcc and Vss lines at the board power supply source, and be sure to insert bypass capacitors CB close to the pins.

**Figure 20.7 External Circuitry Recommended for PLL Circuit**

Section 21 Power-Down Modes

In addition to the normal program execution state, this LSI has five power-down modes in which operation of the CPU and oscillator is halted and power consumption is reduced. Low-power operation can be achieved by individually controlling the CPU, on-chip peripheral modules, and so on.

This LSI's operating modes are as follows:

1. High-speed mode
2. Medium-speed mode
3. Sleep mode
4. Module stop mode
5. Software standby mode
6. Hardware standby mode

2. to 6. are power-down modes. Sleep mode is a CPU state, medium-speed mode is a CPU and bus master state, and module stop mode is an internal peripheral function (including bus masters other than the CPU) state. Some of these states can be combined.

After a reset, the LSI is in high-speed mode.

Figure 21.1 shows possible transitions between modes. Table 21.1 shows the conditions of transition made by the SLEEP instruction and recovery from power-down mode by an interrupt. Table 21.2 shows the internal states in each mode.

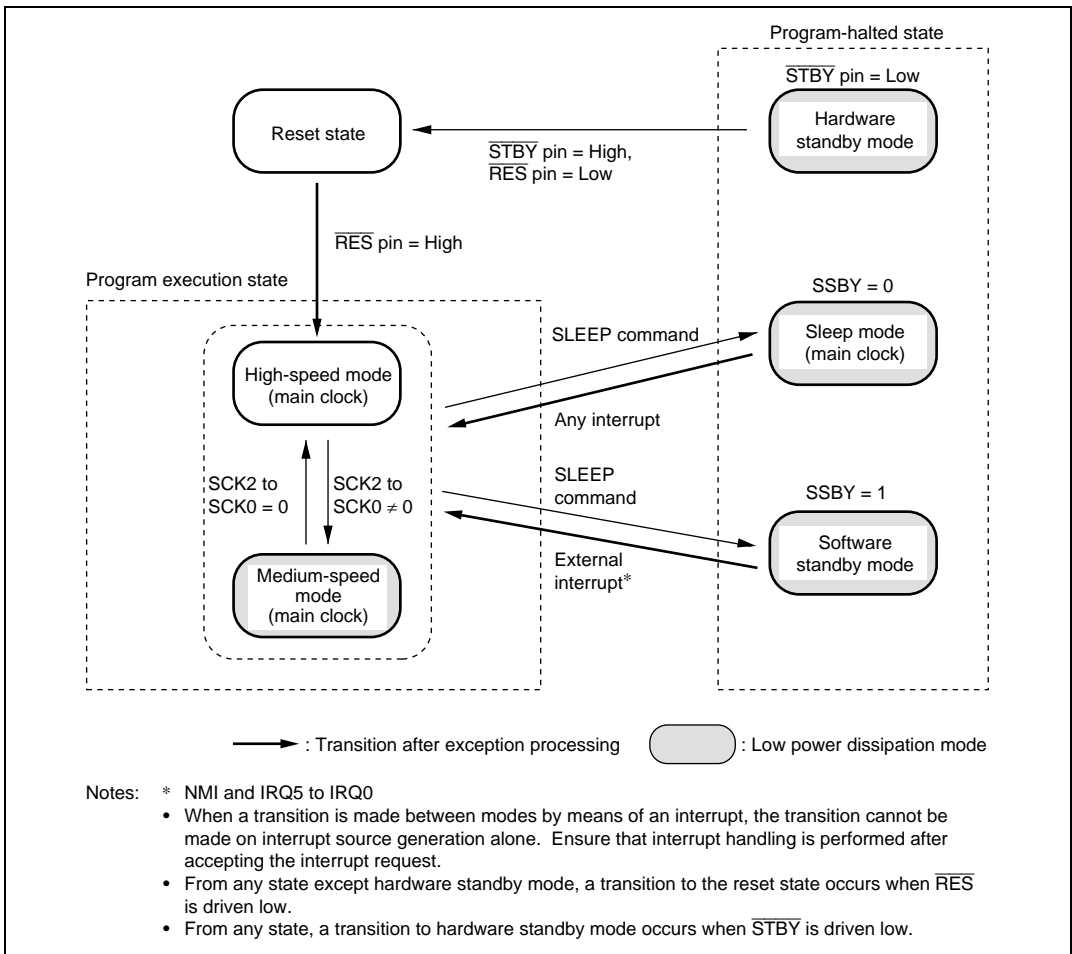

Figure 21.1 Mode Transition Diagram

Table 21.1 Low Power Consumption Mode Transition Conditions

Pre-Transition State	Status of Control Bit at Transition	State after Transition Invoked by SLEEP Command	State after Transition Back from Low Power Mode Invoked by Interrupt
	SSBY		
High-speed/ Medium-speed	0	Sleep	High-speed/Medium-speed
	1	Software standby	High-speed/Medium-speed

Table 21.2 LSI Internal States in Each Mode

Function		High-Speed	Medium-Speed	Sleep	Module Stop	Software Standby	Hardware Standby
System clock pulse generator		Operate	Operate	Operate	Operate	Halted	Halted
CPU	Instructions Registers	Operate	Medium-speed operation	Halted (retained)	High/medium-speed operation	Halted (retained)	Halted (undefined)
External interrupts	NMI IRQ5 to IRQ0	Operate	Operate	Operate	Operate	Operate	Halted
Peripheral functions	PBC DTC	Operate	Medium-speed operation	Operate	Halted (retained)	Halted (retained)	Halted (reset)
	I/O	Operate	Operate	Operate	Operate	Retained	High impedance
	TPU TMR PPG	Operate	Operate	Operate	Halted (retained)	Halted (retained)	Halted (reset)
	WDT	Operate	Operate	Operate	Operate	Halted (retained)	Halted (reset)
	SCI HCAN A/D	Operate	Operate	Operate	Halted* (reset/retained)	Halted (reset)	Halted (reset)
	RAM	Operate	Medium-speed operation	Operate (DTC)	Operate	Retained	Retained
	SSU	Operate	Operate	Operate	Halted (reset)	Halted (reset)	Halted (reset)

Notes: Halted (retained) means that internal register values are retained. The internal state is in the operation suspended state.

Halted (reset) means that internal register values and internal states are initialized.

In module stop mode, only modules for which a stop setting has been made are halted (reset or retained).

* The SCI's TDR, RDR, and SSR are halted (reset), and the other registers are halted (retained).

21.1 Register Descriptions

Registers related to the power down mode are shown below. For details on the system clock control register (SCKCR), refer to section 20.1.1, System Clock Control Register (SCKCR).

- System clock control register (SCKCR)
- Standby control register (SBYCR)
- Module stop control register A (MSTPCRA)
- Module stop control register B (MSTPCRB)
- Module stop control register C (MSTPCRC)

21.1.1 Standby Control Register (SBYCR)

SBYCR is an 8-bit readable/writable register that performs software standby mode control.

Bit	Bit Name	Initial Value	R/W	Description
7	SSBY	0	R/W	<p>Software Standby</p> <p>This bit specifies the transition mode after executing the SLEEP instruction</p> <p>0: Shifts to sleep mode when the SLEEP instruction is executed</p> <p>1: Shifts to software standby mode when the SLEEP instruction is executed</p> <p>This bit does not change when clearing the software standby mode by using external interrupts and shifting to normal operation. This bit should be written with 0 when clearing.</p>

Bit	Bit Name	Initial Value	R/W	Description	
6	STS2	0	R/W	Standby Timer Select 2 to 0	
5	STS1	0	R/W	<p>These bits select the MCU wait time for clock settling when software standby mode is cancelled by an external interrupt. With a crystal oscillator (table 21.3), select a wait time of 8 ms (oscillation settling time) or more, depending on the operating frequency. With an external clock, select a wait time of 2 ms or more.</p> <p>000: Standby time = 8,192 states 001: Standby time = 16,384 states 010: Standby time = 32,768 states 011: Standby time = 65,536 states 100: Standby time = 131,072 states 101: Standby time = 262,144 states 110: Reserved 111: Standby time = 16 states</p>	
4	STS0	0	R/W		
3	—	1	R/W		Reserved The write value should always be 0.
2 to 0	—	All 0	—		Reserved These bits are always read as 0 and cannot be modified.

21.1.2 Module Stop Control Registers A to C (MSTPCRA to MSTPCRC)

MSTPCR is comprised of three 8-bit readable/writable registers, and performs module stop mode control. Setting a bit to 1 causes the corresponding module to enter module stop mode. Clearing the bit to 0 clears the module stop mode.

- MSTPCRA

Bit	Bit Name	Initial Value	R/W	Module
7	MSTPA7*	0	R/W	
6	MSTPA6	0	R/W	Data transfer controller (DTC)
5	MSTPA5	1	R/W	16-bit timer pulse unit (TPU)
4	MSTPA4	1	R/W	8-bit timer (TMR_1, TMR_0)
3	MSTPA3	1	R/W	Programmable pulse generator (PPG)
2	MSTPA2*	1	R/W	
1	MSTPA1	1	R/W	A/D converter
0	MSTPA0	1	R/W	8-bit timer (TMR_3, TMR_2)

- MSTPCRB

Bit	Bit Name	Initial Value	R/W	Module
7	MSTPB7	1	R/W	Serial communication interface 0 (SCI0)
6	MSTPB6*	1	R/W	
5	MSTPB5	1	R/W	Serial communication interface 2 (SCI2)
4	MSTPB4*	1	R/W	
3	MSTPB3*	1	R/W	
2	MSTPB2*	1	R/W	
1	MSTPB1*	1	R/W	
0	MSTPB0*	1	R/W	

- MSTPCRC

Bit	Bit Name	Initial Value	R/W	Module
7	MSTPC7*	1	R/W	
6	MSTPC6*	1	R/W	
5	MSTPC5*	1	R/W	
4	MSTPC4	1	R/W	PC break controller (PBC)
3	MSTPC3	1	R/W	Controller area network (HCAN)
2	MSTPC2	1	R/W	Synchronous serial communication unit (SSU)
1	MSTPC1*	1	R/W	
0	MSTPC0*	1	R/W	

Note: * MSTPA7 is a readable/writable bit with an initial value of 0. The write value should always be 0.
MSTPA2, MSTPB6, MSTPB4 to MSTPB0, MSTPC7 to MSTPC5, MSTPC1, and MSTPC0 are readable/writable bits with an initial value of 1. The write value should always be 1.

21.2 Medium-Speed Mode

When the SCK2 to SCK0 bits in SCKCR are set to 1, the operating mode changes to medium-speed mode as soon as the current bus cycle ends. In medium-speed mode, the CPU operates on the operating clock ($\phi/2$, $\phi/4$, $\phi/8$, $\phi/16$, or $\phi/32$) specified by the SCK2 to SCK0 bits. Bus masters (DTC) other than the CPU also operate in medium-speed mode. On-chip peripheral modules other than bus masters always operate on the high-speed clock (ϕ).

In medium-speed mode, a bus access is executed in the specified number of states with respect to the bus master operating clock. For example, if $\phi/4$ is selected as the operating clock, on-chip memory is accessed in 4 states, and internal I/O registers in 8 states.

Medium-speed mode is cleared by clearing all of bits SCK2 to SCK0 to 0. A transition is made to high-speed mode and medium-speed mode is cleared at the end of the current bus cycle.

If a SLEEP instruction is executed when the SSBY bit in SBYCR is cleared to 0, a transition is made to sleep mode. When sleep mode is cleared by an interrupt, medium-speed mode is restored.

When the SLEEP instruction is executed with the SSBY bit = 1, operation shifts to the software standby mode. When software standby mode is cleared by an external interrupt, medium-speed mode is restored.

When the $\overline{\text{RES}}$ pin is set low and medium-speed mode is cancelled, operation shifts to the reset state. The same applies in the case of a reset caused by overflow of the watchdog timer.

When the $\overline{\text{STBY}}$ pin is driven low, a transition is made to hardware standby mode.

Figure 21.2 shows the timing for transition to and clearance of medium-speed mode.

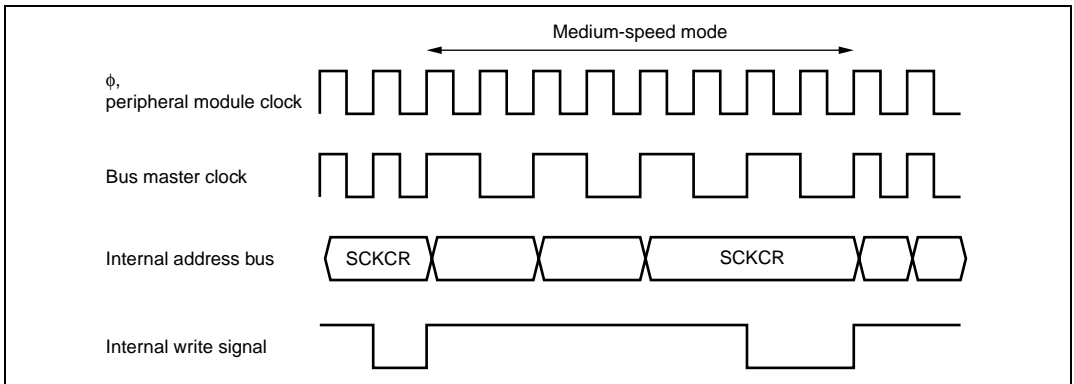

Figure 21.2 Medium-Speed Mode Transition and Clearance Timing

21.3 Sleep Mode

21.3.1 Transition to Sleep Mode

If SLEEP instruction is executed when the SBYCR SSBY bit = 0, the CPU enters the sleep mode. In sleep mode, CPU operation stops, however the contents of the CPU's internal registers are retained. Other peripheral modules do not stop.

21.3.2 Clearing Sleep Mode

Sleep mode is cleared by any interrupt, or signals at the $\overline{\text{RES}}$, or $\overline{\text{STBY}}$ pins.

- **Exiting Sleep Mode by Interrupts:**
When an interrupt occurs, sleep mode is exited and interrupt exception processing starts. Sleep mode is not exited if the interrupt is disabled, or if interrupts other than NMI are masked by the CPU.
- **Exiting Sleep Mode by $\overline{\text{RES}}$ pin:**
Setting the $\overline{\text{RES}}$ pin low level selects the reset state. After the stipulated reset input duration, driving the $\overline{\text{RES}}$ pin high level restart the CPU performing reset exception processing.

- Exiting Sleep Mode by \overline{STBY} Pin:
When the \overline{STBY} pin level is driven low, a transition is made to hardware standby mode.

21.4 Software Standby Mode

21.4.1 Transition to Software Standby Mode

A transition is made to software standby mode if the SLEEP instruction is executed when the SBYCR SSBY bit is set to 1. In this mode, the CPU, on-chip peripheral modules, and oscillator, all stop. However, the contents of the CPU's internal registers, on-chip RAM data, and the states of on-chip peripheral modules other than the SCI, SSU, HCAN, A/D converter, and the states of I/O ports, are retained. In this mode, the oscillator stops, and therefore power consumption is significantly reduced.

21.4.2 Clearing Software Standby Mode

Software standby mode is cleared by an external interrupt (NMI pin, or pins $\overline{IRQ5}$ to $\overline{IRQ0}$), or by means of the \overline{RES} pin or \overline{STBY} pin.

- Clearing with an interrupt
When an NMI or $\overline{IRQ5}$ to $\overline{IRQ0}$ interrupt request signal is input, clock oscillation starts, and after the time set in bits STS2 to STS0 in SBYCR has elapsed, stable clocks are supplied to the entire chip, software standby mode is cleared, and interrupt exception handling is started.
When clearing software standby mode with an $\overline{IRQ5}$ to $\overline{IRQ0}$ interrupt, set the corresponding enable bit to 1 and ensure that no interrupt with a higher priority than interrupts $\overline{IRQ5}$ to $\overline{IRQ0}$ is generated. Software standby mode cannot be cleared if the interrupt has been masked on the CPU side or has been designated as a DTC activation source.
- Clearing with the \overline{RES} pin
When the \overline{RES} pin is driven low, clock oscillation is started. At the same time as clock oscillation starts, clocks are supplied to the entire chip. Note that the \overline{RES} pin must be held low until clock oscillation settles. When the \overline{RES} pin goes high, the CPU begins reset exception handling.
- Clearing with the \overline{STBY} pin
When the \overline{STBY} pin is driven low, a transition is made to hardware standby mode.

21.4.3 Setting Oscillation Stabilization Time after Clearing Software Standby Mode

Bits STS2 to STS0 in SBYCR should be set as described below.

- Using a Crystal Oscillator:
Set bits STS2 to STS0 so that the standby time is at least 8 ms (the oscillation settling time). Table 21.3 shows the standby times for different operating frequencies and settings of bits STS2 to STS0.
- Using an External Clock
The PLL circuit requires a time for settling. Set bits STS2 to STS0 so that the standby time is at least 2 ms(the oscillation settling time).

Table 21.3 Oscillation Stabilization Time Settings

STS2	STS1	STS0	Standby Time	24 MHz	20 MHz	16 MHz	12 MHz	10 MHz	8 MHz	6 MHz	4 MHz	Unit
0	0	0	8,192 states	0.34	0.41	0.51	0.68	0.8	1.0	1.3	2.0	ms
		1	16,384 states	0.68	0.82	1.0	1.3	1.6	2.0	2.7	4.1	
	1	0	32,768 states	1.4	1.6	2.0	2.7	3.3	4.1	5.5	8.2	
		1	65,536 states	2.7	3.3	4.1	5.5	6.6	8.2	10.9	16.4	
1	0	0	131,072 states	5.5	6.6	8.2	10.9	13.1	16.4	21.8	32.8	
		1	262,144 states	10.9	13.1	16.4	21.8	26.2	32.8	43.6	65.6	
	1	0	Reserved	—	—	—	—	—	—	—	—	—
		1	16 states*	0.7	0.8	1.0	1.3	1.6	2.0	1.7	4.0	

■: Recommended time setting

Note: * Cannot be used in this LSI.

21.4.4 Software Standby Mode Application Example

Figure 21.3 shows an example in which a transition is made to software standby mode at the falling edge on the NMI pin, and software standby mode is cleared at the rising edge on the NMI pin.

In this example, an NMI interrupt is accepted with the NMIEG bit in SYSCR cleared to 0 (falling edge specification), then the NMIEG bit is set to 1 (rising edge specification), the SSBY bit is set to 1, and a SLEEP instruction is executed, causing a transition to software standby mode.

Software standby mode is then cleared at the rising edge on the NMI pin.

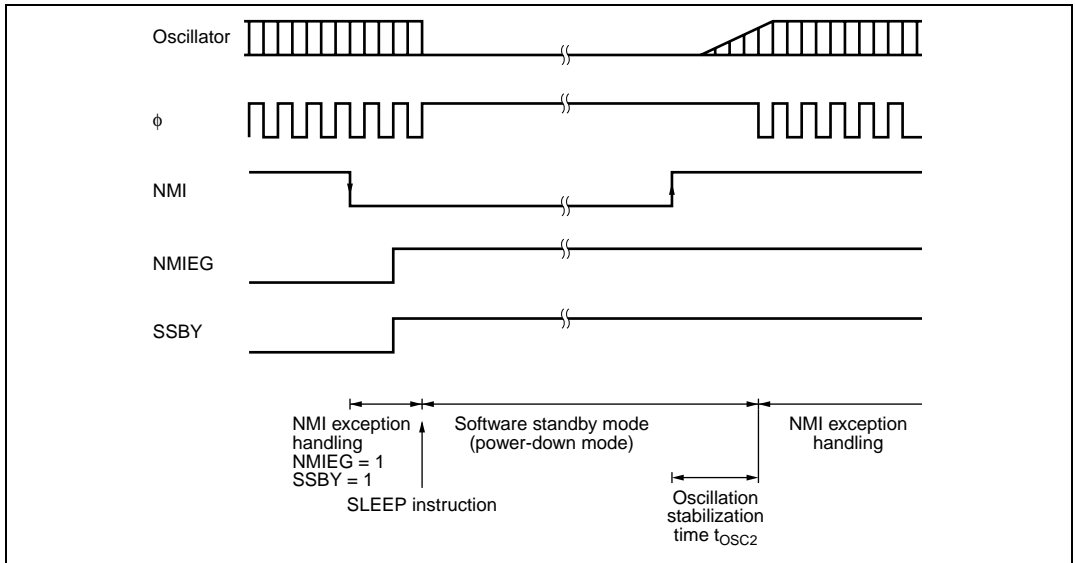

Figure 21.3 Software Standby Mode Application Example

21.5 Hardware Standby Mode

21.5.1 Transition to Hardware Standby Mode

When the $\overline{\text{STBY}}$ pin is driven low, a transition is made to hardware standby mode from any mode.

In hardware standby mode, all functions enter the reset state and stop operation, resulting in a significant reduction in power consumption. As long as the prescribed voltage is supplied, on-chip RAM data is retained. I/O ports are set to the high-impedance state.

In order to retain on-chip RAM data, the RAME bit in SYSCR should be cleared to 0 before driving the $\overline{\text{STBY}}$ pin low.

Do not change the state of the mode pins (MD2 to MD0) while this LSI is in hardware standby mode.

21.5.2 Clearing Hardware Standby Mode

Hardware standby mode is cleared by means of the $\overline{\text{STBY}}$ pin and the $\overline{\text{RES}}$ pin. When the $\overline{\text{STBY}}$ pin is driven high while the $\overline{\text{RES}}$ pin is low, the reset state is set and clock oscillation is started. Ensure that the $\overline{\text{RES}}$ pin is held low until the clock oscillator settles (at least 8 ms—the oscillation settling time—when using a crystal oscillator). When the $\overline{\text{RES}}$ pin is subsequently driven high, a transition is made to the program execution state via the reset exception handling state.

21.5.3 Hardware Standby Mode Timings

Timing of Transition to Hardware Standby Mode

1. To retain RAM contents with the RAME bit set to 1 in SYSCR

Drive the $\overline{\text{RES}}$ signal low at least 10 states before the $\overline{\text{STBY}}$ signal goes low, as shown in figure 21.4. After $\overline{\text{STBY}}$ has gone low, $\overline{\text{RES}}$ has to wait for at least 0 ns before becoming high.

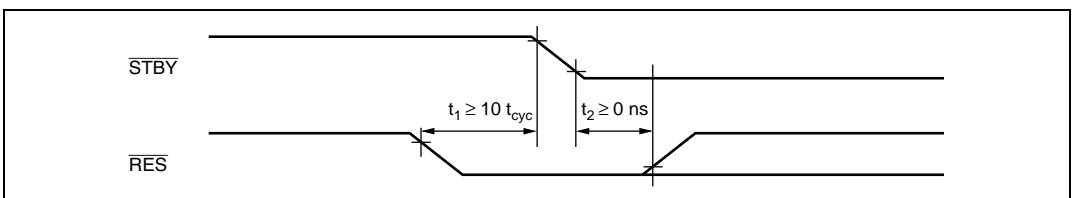

Figure 21.4 Timing of Transition to Hardware Standby Mode

- To retain RAM contents with the RAME bit cleared to 0 in SYSCR, or when RAM contents do not need to be retained

$\overline{\text{RES}}$ does not have to be driven low as in the above case.

Timing of Recovery from Hardware Standby Mode

Drive the $\overline{\text{RES}}$ signal low approximately 100 ns or more before $\overline{\text{STBY}}$ goes high to execute a power-on reset.

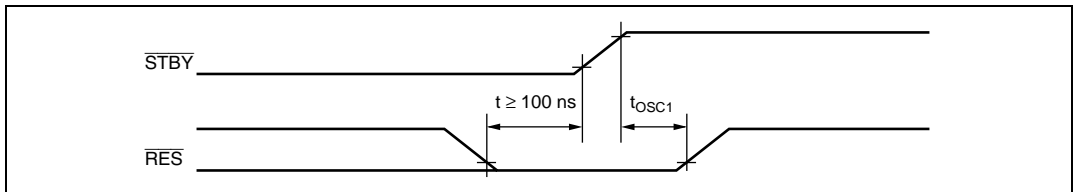

Figure 21.5 Timing of Recovery from Hardware Standby Mode

21.6 Module Stop Mode

Module stop mode can be set for individual on-chip peripheral modules.

When the corresponding MSTP bit in MSTPCR is set to 1, module operation stops at the end of the bus cycle and a transition is made to module stop mode. The CPU continues operating independently.

When the corresponding MSTP bit is cleared to 0, module stop mode is cleared and the module starts operating at the end of the bus cycle. In module stop mode, the internal states of modules other than the SCI*, HCAN, and A/D converter are retained.

After reset clearance, all modules other than DTC are in module stop mode.

When an on-chip peripheral module is in module stop mode, read/write access to its registers is disabled.

Note: * The internal states of some SCI registers are retained.

21.7 ϕ Clock Output Disabling Function

The output of the ϕ clock can be controlled by means of the PSTOP bit in SCKCR, and DDR for the corresponding port. When the PSTOP bit is set to 1, the ϕ clock stops at the end of the bus cycle, and ϕ output goes high. ϕ clock output is enabled when the PSTOP bit is cleared to 0. When DDR for the corresponding port is cleared to 0, ϕ clock output is disabled and input port mode is set. Table 21.4 shows the state of the ϕ pin in each processing state.

Table 21.4 ϕ Pin State in Each Processing State

Register Settings		Normal Mode	Sleep Mode	Software Standby Mode	Hardware Standby Mode
DDR	PSTOP				
0	×	High impedance	High impedance	High impedance	High impedance
1	0	ϕ output	ϕ output	Fixed high	High impedance
1	1	Fixed high	Fixed high	Fixed high	High impedance

21.8 Usage Notes

21.8.1 I/O Port Status

In software standby mode, I/O port states are retained. Therefore, there is no reduction in current consumption for the output current when a high-level signal is output.

21.8.2 Current Consumption during Oscillation Stabilization Wait Period

Current consumption increases during the oscillation settling wait period.

21.8.3 DTC Module Stop

Depending on the operating status of the DTC, MSTPA6 bit may not be set to 1. Setting of the DTC module stop mode should be carried out only when the respective module is not activated.

For details, refer to section 8, Data Transfer Controller (DTC).

21.8.4 On-Chip Peripheral Module Interrupt

Relevant interrupt operations cannot be performed in module stop mode. Consequently, if module stop mode is entered when an interrupt has been requested, it will not be possible to clear the CPU interrupt source or the DTC activation source.

Interrupts should therefore be disabled before entering module stop mode.

21.8.5 Writing to MSTPCR

MSTPCR should only be written to by the CPU.

Section 22 List of Registers

The register list gives information on the on-chip I/O register addresses, how the register bits are configured, and the register states in each operating mode. The information is given as shown below.

1. Register addresses (address order)
 - Registers are listed from the lower allocation addresses.
 - When the address is 16-bit wide, the address of the upper byte is given in the list.
 - Registers are classified by functional modules.
 - The access size is indicated.
2. Register bits
 - Bit configurations of the registers are described in the same order as the register addresses.
 - Reserved bits are indicated by — in the bit name column.
 - Bit number in the bit-name column indicates that the whole register is allocated as a counter or for holding data.
 - When registers consist of 16 bits, bits are described from the MSB side.
3. Register states in each operating mode
 - Register states are described in the same order as the register addresses.
 - The register states described here are for the basic operating modes. If there is a specific reset for an on-chip peripheral module, refer to the section on that on-chip peripheral module.

22.1 Register Addresses (Address Order)

The data-bus width column indicates the number of bits. The access-state column shows the number of states of the selected basic clock that is required for access to the register.

Register Name	Abbreviation	Number of Bits	Address*	Module	Data Width	Access State
Master control register	MCR	8	H'F800	HCAN	16	4
General status register	GSR	8	H'F801	HCAN	16	4
Bit configuration register	BCR	16	H'F802	HCAN	16	4
Mailbox configuration register	MBCR	16	H'F804	HCAN	16	4
Transmit wait register	TXPR	16	H'F806	HCAN	16	4
Transmit wait cancel register	TXCR	16	H'F808	HCAN	16	4
Transmit acknowledge register	TXACK	16	H'F80A	HCAN	16	4
Abort acknowledge register	ABACK	16	H'F80C	HCAN	16	4
Receive complete register	RXPR	16	H'F80E	HCAN	16	4
Remote request register	RFPR	16	H'F810	HCAN	16	4
Interrupt register	IRR	16	H'F812	HCAN	16	4
Mailbox interrupt mask register	MBIMR	16	H'F814	HCAN	16	4
Interrupt mask register	IMR	16	H'F816	HCAN	16	4
Receive error counter	REC	8	H'F818	HCAN	16	4
Transmit error counter	TEC	8	H'F819	HCAN	16	4
Unread message status register	UMSR	16	H'F81A	HCAN	16	4
Local acceptance filter mask L	LAFML	16	H'F81C	HCAN	16	4
Local acceptance filter mask H	LAFMH	16	H'F81E	HCAN	16	4
Message control 0[1]	MC0[1]	8	H'F820	HCAN	16	4
Message control 0[2]	MC0[2]	8	H'F821	HCAN	16	4
Message control 0[3]	MC0[3]	8	H'F822	HCAN	16	4
Message control 0[4]	MC0[4]	8	H'F823	HCAN	16	4
Message control 0[5]	MC0[5]	8	H'F824	HCAN	16	4
Message control 0[6]	MC0[6]	8	H'F825	HCAN	16	4
Message control 0[7]	MC0[7]	8	H'F826	HCAN	16	4
Message control 0[8]	MC0[8]	8	H'F827	HCAN	16	4

Register Name	Abbreviation	Number of Bits	Address*	Module	Data Width	Access State
Message control 1[1]	MC1[1]	8	H'F828	HCAN	16	4
Message control 1[2]	MC1[2]	8	H'F829	HCAN	16	4
Message control 1[3]	MC1[3]	8	H'F82A	HCAN	16	4
Message control 1[4]	MC1[4]	8	H'F82B	HCAN	16	4
Message control 1[5]	MC1[5]	8	H'F82C	HCAN	16	4
Message control 1[6]	MC1[6]	8	H'F82D	HCAN	16	4
Message control 1[7]	MC1[7]	8	H'F82E	HCAN	16	4
Message control 1[8]	MC1[8]	8	H'F82F	HCAN	16	4
Message control 2[1]	MC2[1]	8	H'F830	HCAN	16	4
Message control 2[2]	MC2[2]	8	H'F831	HCAN	16	4
Message control 2[3]	MC2[3]	8	H'F832	HCAN	16	4
Message control 2[4]	MC2[4]	8	H'F833	HCAN	16	4
Message control 2[5]	MC2[5]	8	H'F834	HCAN	16	4
Message control 2[6]	MC2[6]	8	H'F835	HCAN	16	4
Message control 2[7]	MC2[7]	8	H'F836	HCAN	16	4
Message control 2[8]	MC2[8]	8	H'F837	HCAN	16	4
Message control 3[1]	MC3[1]	8	H'F838	HCAN	16	4
Message control 3[2]	MC3[2]	8	H'F839	HCAN	16	4
Message control 3[3]	MC3[3]	8	H'F83A	HCAN	16	4
Message control 3[4]	MC3[4]	8	H'F83B	HCAN	16	4
Message control 3[5]	MC3[5]	8	H'F83C	HCAN	16	4
Message control 3[6]	MC3[6]	8	H'F83D	HCAN	16	4
Message control 3[7]	MC3[7]	8	H'F83E	HCAN	16	4
Message control 3[8]	MC3[8]	8	H'F83F	HCAN	16	4
Message control 4[1]	MC4[1]	8	H'F840	HCAN	16	4
Message control 4[2]	MC4[2]	8	H'F841	HCAN	16	4
Message control 4[3]	MC4[3]	8	H'F842	HCAN	16	4
Message control 4[4]	MC4[4]	8	H'F843	HCAN	16	4
Message control 4[5]	MC4[5]	8	H'F844	HCAN	16	4
Message control 4[6]	MC4[6]	8	H'F845	HCAN	16	4

Register Name	Abbreviation	Number of Bits	Address*	Module	Data Width	Access State
Message control 4[7]	MC4[7]	8	H'F846	HCAN	16	4
Message control 4[8]	MC4[8]	8	H'F847	HCAN	16	4
Message control 5[1]	MC5[1]	8	H'F848	HCAN	16	4
Message control 5[2]	MC5[2]	8	H'F849	HCAN	16	4
Message control 5[3]	MC5[3]	8	H'F84A	HCAN	16	4
Message control 5[4]	MC5[4]	8	H'F84B	HCAN	16	4
Message control 5[5]	MC5[5]	8	H'F84C	HCAN	16	4
Message control 5[6]	MC5[6]	8	H'F84D	HCAN	16	4
Message control 5[7]	MC5[7]	8	H'F84E	HCAN	16	4
Message control 5[8]	MC5[8]	8	H'F84F	HCAN	16	4
Message control 6[1]	MC6[1]	8	H'F850	HCAN	16	4
Message control 6[2]	MC6[2]	8	H'F851	HCAN	16	4
Message control 6[3]	MC6[3]	8	H'F852	HCAN	16	4
Message control 6[4]	MC6[4]	8	H'F853	HCAN	16	4
Message control 6[5]	MC6[5]	8	H'F854	HCAN	16	4
Message control 6[6]	MC6[6]	8	H'F855	HCAN	16	4
Message control 6[7]	MC6[7]	8	H'F856	HCAN	16	4
Message control 6[8]	MC6[8]	8	H'F857	HCAN	16	4
Message control 7[1]	MC7[1]	8	H'F858	HCAN	16	4
Message control 7[2]	MC7[2]	8	H'F859	HCAN	16	4
Message control 7[3]	MC7[3]	8	H'F85A	HCAN	16	4
Message control 7[4]	MC7[4]	8	H'F85B	HCAN	16	4
Message control 7[5]	MC7[5]	8	H'F85C	HCAN	16	4
Message control 7[6]	MC7[6]	8	H'F85D	HCAN	16	4
Message control 7[7]	MC7[7]	8	H'F85E	HCAN	16	4
Message control 7[8]	MC7[8]	8	H'F85F	HCAN	16	4
Message control 8[1]	MC8[1]	8	H'F860	HCAN	16	4
Message control 8[2]	MC8[2]	8	H'F861	HCAN	16	4
Message control 8[3]	MC8[3]	8	H'F862	HCAN	16	4
Message control 8[4]	MC8[4]	8	H'F863	HCAN	16	4

Register Name	Abbreviation	Number of Bits	Address*	Module	Data Width	Access State
Message control 8[5]	MC8[5]	8	H'F864	HCAN	16	4
Message control 8[6]	MC8[6]	8	H'F865	HCAN	16	4
Message control 8[7]	MC8[7]	8	H'F866	HCAN	16	4
Message control 8[8]	MC8[8]	8	H'F867	HCAN	16	4
Message control 9[1]	MC9[1]	8	H'F868	HCAN	16	4
Message control 9[2]	MC9[2]	8	H'F869	HCAN	16	4
Message control 9[3]	MC9[3]	8	H'F86A	HCAN	16	4
Message control 9[4]	MC9[4]	8	H'F86B	HCAN	16	4
Message control 9[5]	MC9[5]	8	H'F86C	HCAN	16	4
Message control 9[6]	MC9[6]	8	H'F86D	HCAN	16	4
Message control 9[7]	MC9[7]	8	H'F86E	HCAN	16	4
Message control 9[8]	MC9[8]	8	H'F86F	HCAN	16	4
Message control 10[1]	MC10[1]	8	H'F870	HCAN	16	4
Message control 10[2]	MC10[2]	8	H'F871	HCAN	16	4
Message control 10[3]	MC10[3]	8	H'F872	HCAN	16	4
Message control 10[4]	MC10[4]	8	H'F873	HCAN	16	4
Message control 10[5]	MC10[5]	8	H'F874	HCAN	16	4
Message control 10[6]	MC10[6]	8	H'F875	HCAN	16	4
Message control 10[7]	MC10[7]	8	H'F876	HCAN	16	4
Message control 10[8]	MC10[8]	8	H'F877	HCAN	16	4
Message control 11[1]	MC11[1]	8	H'F878	HCAN	16	4
Message control 11[2]	MC11[2]	8	H'F879	HCAN	16	4
Message control 11[3]	MC11[3]	8	H'F87A	HCAN	16	4
Message control 11[4]	MC11[4]	8	H'F87B	HCAN	16	4
Message control 11[5]	MC11[5]	8	H'F87C	HCAN	16	4
Message control 11[6]	MC11[6]	8	H'F87D	HCAN	16	4
Message control 11[7]	MC11[7]	8	H'F87E	HCAN	16	4
Message control 11[8]	MC11[8]	8	H'F87F	HCAN	16	4
Message control 12[1]	MC12[1]	8	H'F880	HCAN	16	4
Message control 12[2]	MC12[2]	8	H'F881	HCAN	16	4

Register Name	Abbreviation	Number of Bits	Address*	Module	Data Width	Access State
Message control 12[3]	MC12[3]	8	H'F882	HCAN	16	4
Message control 12[4]	MC12[4]	8	H'F883	HCAN	16	4
Message control 12[5]	MC12[5]	8	H'F884	HCAN	16	4
Message control 12[6]	MC12[6]	8	H'F885	HCAN	16	4
Message control 12[7]	MC12[7]	8	H'F886	HCAN	16	4
Message control 12[8]	MC12[8]	8	H'F887	HCAN	16	4
Message control 13[1]	MC13[1]	8	H'F888	HCAN	16	4
Message control 13[2]	MC13[2]	8	H'F889	HCAN	16	4
Message control 13[3]	MC13[3]	8	H'F88A	HCAN	16	4
Message control 13[4]	MC13[4]	8	H'F88B	HCAN	16	4
Message control 13[5]	MC13[5]	8	H'F88C	HCAN	16	4
Message control 13[6]	MC13[6]	8	H'F88D	HCAN	16	4
Message control 13[7]	MC13[7]	8	H'F88E	HCAN	16	4
Message control 13[8]	MC13[8]	8	H'F88F	HCAN	16	4
Message control 14[1]	MC14[1]	8	H'F890	HCAN	16	4
Message control 14[2]	MC14[2]	8	H'F891	HCAN	16	4
Message control 14[3]	MC14[3]	8	H'F892	HCAN	16	4
Message control 14[4]	MC14[4]	8	H'F893	HCAN	16	4
Message control 14[5]	MC14[5]	8	H'F894	HCAN	16	4
Message control 14[6]	MC14[6]	8	H'F895	HCAN	16	4
Message control 14[7]	MC14[7]	8	H'F896	HCAN	16	4
Message control 14[8]	MC14[8]	8	H'F897	HCAN	16	4
Message control 15[1]	MC15[1]	8	H'F898	HCAN	16	4
Message control 15[2]	MC15[2]	8	H'F899	HCAN	16	4
Message control 15[3]	MC15[3]	8	H'F89A	HCAN	16	4
Message control 15[4]	MC15[4]	8	H'F89B	HCAN	16	4
Message control 15[5]	MC15[5]	8	H'F89C	HCAN	16	4
Message control 15[6]	MC15[6]	8	H'F89D	HCAN	16	4
Message control 15[7]	MC15[7]	8	H'F89E	HCAN	16	4
Message control 15[8]	MC15[8]	8	H'F89F	HCAN	16	4

Register Name	Abbreviation	Number of Bits	Address*	Module	Data Width	Access State
Message data 0[1]	MD0[1]	8	H'F8B0	HCAN	16	4
Message data 0[2]	MD0[2]	8	H'F8B1	HCAN	16	4
Message data 0[3]	MD0[3]	8	H'F8B2	HCAN	16	4
Message data 0[4]	MD0[4]	8	H'F8B3	HCAN	16	4
Message data 0[5]	MD0[5]	8	H'F8B4	HCAN	16	4
Message data 0[6]	MD0[6]	8	H'F8B5	HCAN	16	4
Message data 0[7]	MD0[7]	8	H'F8B6	HCAN	16	4
Message data 0[8]	MD0[8]	8	H'F8B7	HCAN	16	4
Message data 1[1]	MD1[1]	8	H'F8B8	HCAN	16	4
Message data 1[2]	MD1[2]	8	H'F8B9	HCAN	16	4
Message data 1[3]	MD1[3]	8	H'F8BA	HCAN	16	4
Message data 1[4]	MD1[4]	8	H'F8BB	HCAN	16	4
Message data 1[5]	MD1[5]	8	H'F8BC	HCAN	16	4
Message data 1[6]	MD1[6]	8	H'F8BD	HCAN	16	4
Message data 1[7]	MD1[7]	8	H'F8BE	HCAN	16	4
Message data 1[8]	MD1[8]	8	H'F8BF	HCAN	16	4
Message data 2[1]	MD2[1]	8	H'F8C0	HCAN	16	4
Message data 2[2]	MD2[2]	8	H'F8C1	HCAN	16	4
Message data 2[3]	MD2[3]	8	H'F8C2	HCAN	16	4
Message data 2[4]	MD2[4]	8	H'F8C3	HCAN	16	4
Message data 2[5]	MD2[5]	8	H'F8C4	HCAN	16	4
Message data 2[6]	MD2[6]	8	H'F8C5	HCAN	16	4
Message data 2[7]	MD2[7]	8	H'F8C6	HCAN	16	4
Message data 2[8]	MD2[8]	8	H'F8C7	HCAN	16	4
Message data 3[1]	MD3[1]	8	H'F8C8	HCAN	16	4
Message data 3[2]	MD3[2]	8	H'F8C9	HCAN	16	4
Message data 3[3]	MD3[3]	8	H'F8CA	HCAN	16	4
Message data 3[4]	MD3[4]	8	H'F8CB	HCAN	16	4
Message data 3[5]	MD3[5]	8	H'F8CC	HCAN	16	4
Message data 3[6]	MD3[6]	8	H'F8CD	HCAN	16	4

Register Name	Abbreviation	Number of Bits	Address*	Module	Data Width	Access State
Message data 3[7]	MD3[7]	8	H'F8CE	HCAN	16	4
Message data 3[8]	MD3[8]	8	H'F8CF	HCAN	16	4
Message data 4[1]	MD4[1]	8	H'F8D0	HCAN	16	4
Message data 4[2]	MD4[2]	8	H'F8D1	HCAN	16	4
Message data 4[3]	MD4[3]	8	H'F8D2	HCAN	16	4
Message data 4[4]	MD4[4]	8	H'F8D3	HCAN	16	4
Message data 4[5]	MD4[5]	8	H'F8D4	HCAN	16	4
Message data 4[6]	MD4[6]	8	H'F8D5	HCAN	16	4
Message data 4[7]	MD4[7]	8	H'F8D6	HCAN	16	4
Message data 4[8]	MD4[8]	8	H'F8D7	HCAN	16	4
Message data 5[1]	MD5[1]	8	H'F8D8	HCAN	16	4
Message data 5[2]	MD5[2]	8	H'F8D9	HCAN	16	4
Message data 5[3]	MD5[3]	8	H'F8DA	HCAN	16	4
Message data 5[4]	MD5[4]	8	H'F8DB	HCAN	16	4
Message data 5[5]	MD5[5]	8	H'F8DC	HCAN	16	4
Message data 5[6]	MD5[6]	8	H'F8DD	HCAN	16	4
Message data 5[7]	MD5[7]	8	H'F8DE	HCAN	16	4
Message data 5[8]	MD5[8]	8	H'F8DF	HCAN	16	4
Message data 6[1]	MD6[1]	8	H'F8E0	HCAN	16	4
Message data 6[2]	MD6[2]	8	H'F8E1	HCAN	16	4
Message data 6[3]	MD6[3]	8	H'F8E2	HCAN	16	4
Message data 6[4]	MD6[4]	8	H'F8E3	HCAN	16	4
Message data 6[5]	MD6[5]	8	H'F8E4	HCAN	16	4
Message data 6[6]	MD6[6]	8	H'F8E5	HCAN	16	4
Message data 6[7]	MD6[7]	8	H'F8E6	HCAN	16	4
Message data 6[8]	MD6[8]	8	H'F8E7	HCAN	16	4
Message data 7[1]	MD7[1]	8	H'F8E8	HCAN	16	4
Message data 7[2]	MD7[2]	8	H'F8E9	HCAN	16	4
Message data 7[3]	MD7[3]	8	H'F8EA	HCAN	16	4
Message data 7[4]	MD7[4]	8	H'F8EB	HCAN	16	4

Register Name	Abbreviation	Number of Bits	Address*	Module	Data Width	Access State
Message data 7[5]	MD7[5]	8	H'F8EC	HCAN	16	4
Message data 7[6]	MD7[6]	8	H'F8ED	HCAN	16	4
Message data 7[7]	MD7[7]	8	H'F8EE	HCAN	16	4
Message data 7[8]	MD7[8]	8	H'F8EF	HCAN	16	4
Message data 8[1]	MD8[1]	8	H'F8F0	HCAN	16	4
Message data 8[2]	MD8[2]	8	H'F8F1	HCAN	16	4
Message data 8[3]	MD8[3]	8	H'F8F2	HCAN	16	4
Message data 8[4]	MD8[4]	8	H'F8F3	HCAN	16	4
Message data 8[5]	MD8[5]	8	H'F8F4	HCAN	16	4
Message data 8[6]	MD8[6]	8	H'F8F5	HCAN	16	4
Message data 8[7]	MD8[7]	8	H'F8F6	HCAN	16	4
Message data 8[8]	MD8[8]	8	H'F8F7	HCAN	16	4
Message data 9[1]	MD9[1]	8	H'F8F8	HCAN	16	4
Message data 9[2]	MD9[2]	8	H'F8F9	HCAN	16	4
Message data 9[3]	MD9[3]	8	H'F8FA	HCAN	16	4
Message data 9[4]	MD9[4]	8	H'F8FB	HCAN	16	4
Message data 9[5]	MD9[5]	8	H'F8FC	HCAN	16	4
Message data 9[6]	MD9[6]	8	H'F8FD	HCAN	16	4
Message data 9[7]	MD9[7]	8	H'F8FE	HCAN	16	4
Message data 9[8]	MD9[8]	8	H'F8FF	HCAN	16	4
Message data 10[1]	MD10[1]	8	H'F900	HCAN	16	4
Message data 10[2]	MD10[2]	8	H'F901	HCAN	16	4
Message data 10[3]	MD10[3]	8	H'F902	HCAN	16	4
Message data 10[4]	MD10[4]	8	H'F903	HCAN	16	4
Message data 10[5]	MD10[5]	8	H'F904	HCAN	16	4
Message data 10[6]	MD10[6]	8	H'F905	HCAN	16	4
Message data 10[7]	MD10[7]	8	H'F906	HCAN	16	4
Message data 10[8]	MD10[8]	8	H'F907	HCAN	16	4
Message data 11[1]	MD11[1]	8	H'F908	HCAN	16	4
Message data 11[2]	MD11[2]	8	H'F909	HCAN	16	4

Register Name	Abbreviation	Number of Bits	Address*	Module	Data Width	Access State
Message data 11[3]	MD11[3]	8	H'F90A	HCAN	16	4
Message data 11[4]	MD11[4]	8	H'F90B	HCAN	16	4
Message data 11[5]	MD11[5]	8	H'F90C	HCAN	16	4
Message data 11[6]	MD11[6]	8	H'F90D	HCAN	16	4
Message data 11[7]	MD11[7]	8	H'F90E	HCAN	16	4
Message data 11[8]	MD11[8]	8	H'F90F	HCAN	16	4
Message data 12[1]	MD12[1]	8	H'F910	HCAN	16	4
Message data 12[2]	MD12[2]	8	H'F911	HCAN	16	4
Message data 12[3]	MD12[3]	8	H'F912	HCAN	16	4
Message data 12[4]	MD12[4]	8	H'F913	HCAN	16	4
Message data 12[5]	MD12[5]	8	H'F914	HCAN	16	4
Message data 12[6]	MD12[6]	8	H'F915	HCAN	16	4
Message data 12[7]	MD12[7]	8	H'F916	HCAN	16	4
Message data 12[8]	MD12[8]	8	H'F917	HCAN	16	4
Message data 13[1]	MD13[1]	8	H'F918	HCAN	16	4
Message data 13[2]	MD13[2]	8	H'F919	HCAN	16	4
Message data 13[3]	MD13[3]	8	H'F91A	HCAN	16	4
Message data 13[4]	MD13[4]	8	H'F91B	HCAN	16	4
Message data 13[5]	MD13[5]	8	H'F91C	HCAN	16	4
Message data 13[6]	MD13[6]	8	H'F91D	HCAN	16	4
Message data 13[7]	MD13[7]	8	H'F91E	HCAN	16	4
Message data 13[8]	MD13[8]	8	H'F91F	HCAN	16	4
Message data 14[1]	MD14[1]	8	H'F920	HCAN	16	4
Message data 14[2]	MD14[2]	8	H'F921	HCAN	16	4
Message data 14[3]	MD14[3]	8	H'F922	HCAN	16	4
Message data 14[4]	MD14[4]	8	H'F923	HCAN	16	4
Message data 14[5]	MD14[5]	8	H'F924	HCAN	16	4
Message data 14[6]	MD14[6]	8	H'F925	HCAN	16	4
Message data 14[7]	MD14[7]	8	H'F926	HCAN	16	4
Message data 14[8]	MD14[8]	8	H'F927	HCAN	16	4

Register Name	Abbreviation	Number of Bits	Address*	Module	Data Width	Access State
Message data 15[1]	MD15[1]	8	H'F928	HCAN	16	4
Message data 15[2]	MD15[2]	8	H'F929	HCAN	16	4
Message data 15[3]	MD15[3]	8	H'F92A	HCAN	16	4
Message data 15[4]	MD15[4]	8	H'F92B	HCAN	16	4
Message data 15[5]	MD15[5]	8	H'F92C	HCAN	16	4
Message data 15[6]	MD15[6]	8	H'F92D	HCAN	16	4
Message data 15[7]	MD15[7]	8	H'F92E	HCAN	16	4
Message data 15[8]	MD15[8]	8	H'F92F	HCAN	16	4
HCAN monitor register	HCANMON	8	H'FA00	HCAN	16	4
SS control register H_0	SSCRH_0	8	H'FB00	SSU_0	16	3
SS control register L_0	SSCRL_0	8	H'FB01	SSU_0	16	3
SS mode register_0	SSMR_0	8	H'FB02	SSU_0	16	3
SS enable register_0	SSER_0	8	H'FB03	SSU_0	16	3
SS status register_0	SSSR_0	8	H'FB04	SSU_0	16	3
SS transmit data register 0_0	SSTDR0_0	8	H'FB06	SSU_0	16	3
SS transmit data register 1_0	SSTDR1_0	8	H'FB07	SSU_0	16	3
SS transmit data register 2_0	SSTDR2_0	8	H'FB08	SSU_0	16	3
SS transmit data register 3_0	SSTDR3_0	8	H'FB09	SSU_0	16	3
SS receive data register 0_0	SSRDR0_0	8	H'FB0A	SSU_0	16	3
SS receive data register 1_0	SSRDR1_0	8	H'FB0B	SSU_0	16	3
SS receive data register 2_0	SSRDR2_0	8	H'FB0C	SSU_0	16	3
SS receive data register 3_0	SSRDR3_0	8	H'FB0D	SSU_0	16	3
SS control register H_1	SSCRH_1	8	H'FB10	SSU_1	16	3
SS control register L_1	SSCRL_1	8	H'FB11	SSU_1	16	3
SS mode register_1	SSMR_1	8	H'FB12	SSU_1	16	3
SS enable register_1	SSER_1	8	H'FB13	SSU_1	16	3
SS status register_1	SSSR_1	8	H'FB14	SSU_1	16	3
SS transmit data register 0_1	SSTDR0_1	8	H'FB16	SSU_1	16	3
SS transmit data register 1_1	SSTDR1_1	8	H'FB17	SSU_1	16	3
SS transmit data register 2_1	SSTDR2_1	8	H'FB18	SSU_1	16	3

Register Name	Abbreviation	Number of Bits	Address*	Module	Data Width	Access State
SS transmit data register 3_1	SSTDR3_1	8	H'FB19	SSU_1	16	3
SS receive data register 0_1	SSRDR0_1	8	H'FB1A	SSU_1	16	3
SS receive data register 1_1	SSRDR1_1	8	H'FB1B	SSU_1	16	3
SS receive data register 2_1	SSRDR2_1	8	H'FB1C	SSU_1	16	3
SS receive data register 3_1	SSRDR3_1	8	H'FB1D	SSU_1	16	3
Port D realtime input data register	PDRTIDR	8	H'FB40	PORT	16	3
Timer control register_2	TCR_2	8	H'FDC0	TMR_2	8	2
Timer control register_3	TCR_3	8	H'FDC1	TMR_3	8	2
Timer control/status register_2	TCSR_2	8	H'FDC2	TMR_2	8	2
Timer control/status register_3	TCSR_3	8	H'FDC3	TMR_3	8	2
Timer constant register A_2	TCORA_2	8	H'FDC4	TMR_2	8	2
Timer constant register A_3	TCORA_3	8	H'FDC5	TMR_3	8	2
Timer constant register B_2	TCORB_2	8	H'FDC6	TMR_2	8	2
Timer constant register B_3	TCORB_3	8	H'FDC7	TMR_3	8	2
Timer counter_2	TCNT_2	8	H'FDC8	TMR_2	8	2
Timer counter_3	TCNT_3	8	H'FDC9	TMR_3	8	2
Standby control register	SBYCR	8	H'FDE4	SYSTEM	8	2
System control register	SYSCR	8	H'FDE5	SYSTEM	8	2
System clock control register	SCKCR	8	H'FDE6	SYSTEM	8	2
Mode control register	MDCR	8	H'FDE7	SYSTEM	8	2
Module stop control register A	MSTPCRA	8	H'FDE8	SYSTEM	8	2
Module stop control register B	MSTPCRB	8	H'FDE9	SYSTEM	8	2
Module stop control register C	MSTPCRC	8	H'FDEA	SYSTEM	8	2
Low-power control register	LPWRCR	8	H'FDEC	SYSTEM	8	2
Break address register A	BARA	32	H'FE00	PBC	32	2
Break address register B	BARB	32	H'FE04	PBC	32	2
Break control register A	BCRA	8	H'FE08	PBC	8	2
Break control register B	BCRB	8	H'FE09	PBC	8	2
IRQ sense control register H	ISCRH	8	H'FE12	INT	8	2
IRQ sense control register L	ISCR L	8	H'FE13	INT	8	2

Register Name	Abbreviation	Number of Bits	Address*	Module	Data Width	Access State
IRQ enable register	IER	8	H'FE14	INT	8	2
IRQ status register	ISR	8	H'FE15	INT	8	2
DTC enable register A	DTCERA	8	H'FE16	DTC	8	2
DTC enable register B	DTCERB	8	H'FE17	DTC	8	2
DTC enable register C	DTCERC	8	H'FE18	DTC	8	2
DTC enable register D	DTCERD	8	H'FE19	DTC	8	2
DTC enable register E	DTCERE	8	H'FE1A	DTC	8	2
DTC enable register F	DTCERF	8	H'FE1B	DTC	8	2
DTC enable register G	DTCERG	8	H'FE1C	DTC	8	2
DTC vector register	DTVECR	8	H'FE1F	DTC	8	2
PPG output control register	PCR	8	H'FE26	PPG	8	2
PPG output mode register	PMR	8	H'FE27	PPG	8	2
Next data enable register H	NDERH	8	H'FE28	PPG	8	2
Next data enable register L	NDERL	8	H'FE29	PPG	8	2
Output data register H	PODRH	8	H'FE2A	PPG	8	2
Output data register L	PODRL	8	H'FE2B	PPG	8	2
Next data register H	NDRH	8	H'FE2C	PPG	8	2
Next data register L	NDRL	8	H'FE2D	PPG	8	2
Next data register H	NDRH	8	H'FE2E	PPG	8	2
Next data register L	NDRL	8	H'FE2F	PPG	8	2
Port 1 data direction register	P1DDR	8	H'FE30	PORT	8	2
Port 3 data direction register	P3DDR	8	H'FE32	PORT	8	2
Port 7 data direction register	P7DDR	8	H'FE36	PORT	8	2
Port A data direction register	PADDR	8	H'FE39	PORT	8	2
Port B data direction register	PBDDR	8	H'FE3A	PORT	8	2
Port C data direction register	PCDDR	8	H'FE3B	PORT	8	2
Port D data direction register	PDDDR	8	H'FE3C	PORT	8	2
Port F data direction register	PFDDR	8	H'FE3E	PORT	8	2
Port A pull-up MOS control register	PAPCR	8	H'FE40	PORT	8	2
Port B pull-up MOS control register	PBPCR	8	H'FE41	PORT	8	2

Register Name	Abbreviation	Number of Bits	Address*	Module	Data Width	Access State
Port C pull-up MOS control register	PCPCR	8	H'FE42	PORT	8	2
Port D pull-up MOS control register	PDPCR	8	H'FE43	PORT	8	2
Port 3 open drain control register	P3ODR	8	H'FE46	PORT	8	2
Port A open drain control register	PAODR	8	H'FE47	PORT	8	2
Port B open drain control register	PBODR	8	H'FE48	PORT	8	2
Port C open drain control register	PCODR	8	H'FE49	PORT	8	2
Timer control register_3	TCR_3	8	H'FE80	TPU_3	16	2
Timer mode register_3	TMDR_3	8	H'FE81	TPU_3	16	2
Timer I/O control register H_3	TIORH_3	8	H'FE82	TPU_3	16	2
Timer I/O control register L_3	TIORL_3	8	H'FE83	TPU_3	16	2
Timer interrupt enable register_3	TIER_3	8	H'FE84	TPU_3	16	2
Timer status register_3	TSR_3	8	H'FE85	TPU_3	16	2
Timer counter H_3	TCNTH_3	8	H'FE86	TPU_3	16	2
Timer counter L_3	TCNTL_3	8	H'FE87	TPU_3	16	2
Timer general register AH_3	TGRAH_3	8	H'FE88	TPU_3	16	2
Timer general register AL_3	TGRAL_3	8	H'FE89	TPU_3	16	2
Timer general register BH_3	TGRBH_3	8	H'FE8A	TPU_3	16	2
Timer general register BL_3	TGRBL_3	8	H'FE8B	TPU_3	16	2
Timer general register CH_3	TGRCH_3	8	H'FE8C	TPU_3	16	2
Timer general register CL_3	TGRCL_3	8	H'FE8D	TPU_3	16	2
Timer general register DH_3	TGRDH_3	8	H'FE8E	TPU_3	16	2
Timer general register DL_3	TGRDL_3	8	H'FE8F	TPU_3	16	2
Timer control register_4	TCR_4	8	H'FE90	TPU_4	16	2
Timer mode register_4	TMDR_4	8	H'FE91	TPU_4	16	2
Timer I/O control register_4	TIOR_4	8	H'FE92	TPU_4	16	2
Timer interrupt enable register_4	TIER_4	8	H'FE94	TPU_4	16	2
Timer status register_4	TSR_4	8	H'FE95	TPU_4	16	2
Timer counter H_4	TCNTH_4	8	H'FE96	TPU_4	16	2
Timer counter L_4	TCNTL_4	8	H'FE97	TPU_4	16	2
Timer general register AH_4	TGRAH_4	8	H'FE98	TPU_4	16	2

Register Name	Abbreviation	Number of Bits	Address*	Module	Data Width	Access State
Timer general register AL_4	TGRAL_4	8	H'FE99	TPU_4	16	2
Timer general register BH_4	TGRBH_4	8	H'FE9A	TPU_4	16	2
Timer general register BL_4	TGRBL_4	8	H'FE9B	TPU_4	16	2
Timer control register_5	TCR_5	8	H'FEA0	TPU_5	16	2
Timer mode register_5	TMDR_5	8	H'FEA1	TPU_5	16	2
Timer I/O control register_5	TIOR_5	8	H'FEA2	TPU_5	16	2
Timer interrupt enable register_5	TIER_5	8	H'FEA4	TPU_5	16	2
Timer status register_5	TSR_5	8	H'FEA5	TPU_5	16	2
Timer counter H_5	TCNTH_5	8	H'FEA6	TPU_5	16	2
Timer counter L_5	TCNTL_5	8	H'FEA7	TPU_5	16	2
Timer general register AH_5	TGRAH_5	8	H'FEA8	TPU_5	16	2
Timer general register AL_5	TGRAL_5	8	H'FEA9	TPU_5	16	2
Timer general register BH_5	TGRBH_5	8	H'FEAA	TPU_5	16	2
Timer general register BL_5	TGRBL_5	8	H'FEAB	TPU_5	16	2
Timer start register	TSTR	8	H'FEB0	TPU common	16	2
Timer synchro register	TSYR	8	H'FEB1	TPU common	16	2
Interrupt priority register A	IPRA	8	H'FEC0	INT	8	2
Interrupt priority register B	IPRB	8	H'FEC1	INT	8	2
Interrupt priority register C	IPRC	8	H'FEC2	INT	8	2
Interrupt priority register D	IPRD	8	H'FEC3	INT	8	2
Interrupt priority register E	IPRE	8	H'FEC4	INT	8	2
Interrupt priority register F	IPRF	8	H'FEC5	INT	8	2
Interrupt priority register G	IPRG	8	H'FEC6	INT	8	2
Interrupt priority register H	IPRH	8	H'FEC7	INT	8	2
Interrupt priority register J	IPRJ	8	H'FEC9	INT	8	2
Interrupt priority register K	IPRK	8	H'FECA	INT	8	2
Interrupt priority register M	IPRM	8	H'FECC	INT	8	2
RAM emulation register	RAMER	8	H'FEDB	ROM	8	2
Port 1 data register	P1DR	8	H'FF00	PORT	8	2

Register Name	Abbreviation	Number of Bits	Address*	Module	Data Width	Access State
Port 3 data register	P3DR	8	H'FF02	PORT	8	2
Port 7 data register	P7DR	8	H'FF06	PORT	8	2
Port A data register	PADR	8	H'FF09	PORT	8	2
Port B data register	PBDR	8	H'FF0A	PORT	8	2
Port C data register	PCDR	8	H'FF0B	PORT	8	2
Port D data register	PDDR	8	H'FF0C	PORT	8	2
Port F data register	PFDR	8	H'FF0E	PORT	8	2
Timer control register_0	TCR_0	8	H'FF10	TPU_0	16	2
Timer mode register_0	TMDR_0	8	H'FF11	TPU_0	16	2
Timer I/O control register H_0	TIORH_0	8	H'FF12	TPU_0	16	2
Timer I/O control register L_0	TIORL_0	8	H'FF13	TPU_0	16	2
Timer interrupt enable register_0	TIER_0	8	H'FF14	TPU_0	16	2
Timer status register_0	TSR_0	8	H'FF15	TPU_0	16	2
Timer counter H_0	TCNTH_0	8	H'FF16	TPU_0	16	2
Timer counter L_0	TCNTL_0	8	H'FF17	TPU_0	16	2
Timer general register AH_0	TGRAH_0	8	H'FF18	TPU_0	16	2
Timer general register AL_0	TGRAL_0	8	H'FF19	TPU_0	16	2
Timer general register BH_0	TGRBH_0	8	H'FF1A	TPU_0	16	2
Timer general register BL_0	TGRBL_0	8	H'FF1B	TPU_0	16	2
Timer general register CH_0	TGRCH_0	8	H'FF1C	TPU_0	16	2
Timer general register CL_0	TGRCL_0	8	H'FF1D	TPU_0	16	2
Timer general register DH_0	TGRDH_0	8	H'FF1E	TPU_0	16	2
Timer general register DL_0	TGRDL_0	8	H'FF1F	TPU_0	16	2
Timer control register_1	TCR_1	8	H'FF20	TPU_1	16	2
Timer mode register_1	TMDR_1	8	H'FF21	TPU_1	16	2
Timer I/O control register_1	TIOR_1	8	H'FF22	TPU_1	16	2
Timer interrupt enable register_1	TIER_1	8	H'FF24	TPU_1	16	2
Timer status register_1	TSR_1	8	H'FF25	TPU_1	16	2
Timer counter H_1	TCNTH_1	8	H'FF26	TPU_1	16	2
Timer counter L_1	TCNTL_1	8	H'FF27	TPU_1	16	2

Register Name	Abbreviation	Number of Bits	Address*	Module	Data Width	Access State
Timer general register AH_1	TGRAH_1	8	H'FF28	TPU_1	16	2
Timer general register AL_1	TGRAL_1	8	H'FF29	TPU_1	16	2
Timer general register BH_1	TGRBH_1	8	H'FF2A	TPU_1	16	2
Timer general register BL_1	TGRBL_1	8	H'FF2B	TPU_1	16	2
Timer control register_2	TCR_2	8	H'FF30	TPU_2	16	2
Timer mode register_2	TMDR_2	8	H'FF31	TPU_2	16	2
Timer I/O control register_2	TIOR_2	8	H'FF32	TPU_2	16	2
Timer interrupt enable register_2	TIER_2	8	H'FF34	TPU_2	16	2
Timer status register_2	TSR_2	8	H'FF35	TPU_2	16	2
Timer counterH_2	TCNTH_2	8	H'FF36	TPU_2	16	2
Timer counter L_2	TCNTL_2	8	H'FF37	TPU_2	16	2
Timer general register AH_2	TGRAH_2	8	H'FF38	TPU_2	16	2
Timer general register AL_2	TGRAL_2	8	H'FF39	TPU_2	16	2
Timer general register BH_2	TGRBH_2	8	H'FF3A	TPU_2	16	2
Timer general register BL_2	TGRBL_2	8	H'FF3B	TPU_2	16	2
Timer control register_0	TCR_0	8	H'FF68	TMR_0	8	2
Timer control register_1	TCR_1	8	H'FF69	TMR_1	8	2
Timer control/status register_0	TCSR_0	8	H'FF6A	TMR_0	8	2
Timer control/status register_1	TCSR_1	8	H'FF6B	TMR_1	8	2
Time constant register A_0	TCORA_0	8	H'FF6C	TMR_0	8	2
Time constant register A_1	TCORA_1	8	H'FF6D	TMR_1	8	2
Time constant register B_0	TCORB_0	8	H'FF6E	TMR_0	8	2
Time constant register B_1	TCORB_1	8	H'FF6F	TMR_1	8	2
Timer counter_0	TCNT_0	8	H'FF70	TMR_0	8	2
Timer counter_1	TCNT_1	8	H'FF71	TMR_1	8	2
Timer control/status register_0	TCSR_0	8	H'FF74	WDT_0	16	2
Timer counter_0	TCNT_0	8	H'FF75	WDT_0	16	2
Reset control/status register	RSTCSR	8	H'FF77	WDT	16	2
Serial mode register_0	SMR_0	8	H'FF78	SCI_0	8	2
Bit rate register_0	BRR_0	8	H'FF79	SCI_0	8	2

Register Name	Abbreviation	Number of Bits	Address*	Module	Data Width	Access State
Serial control register_0	SCR_0	8	H'FF7A	SCI_0	8	2
Transmit data register_0	TDR_0	8	H'FF7B	SCI_0	8	2
Serial status register_0	SSR_0	8	H'FF7C	SCI_0	8	2
Receive data register_0	RDR_0	8	H'FF7D	SCI_0	8	2
Smart card mode register_0	SCMR_0	8	H'FF7E	SCI_0	8	2
Serial mode register_2	SMR_2	8	H'FF88	SCI_2	8	2
Bit rate register_2	BRR_2	8	H'FF89	SCI_2	8	2
Serial control register_2	SCR_2	8	H'FF8A	SCI_2	8	2
Transmit data register_2	TDR_2	8	H'FF8B	SCI_2	8	2
Serial status register_2	SSR_2	8	H'FF8C	SCI_2	8	2
Receive data register_2	RDR_2	8	H'FF8D	SCI_2	8	2
Smart card mode register_2	SCMR_2	8	H'FF8E	SCI_2	8	2
A/D data register AH	ADDRAH	8	H'FF90	A/D	8	2
A/D data register AL	ADDRAL	8	H'FF91	A/D	8	2
A/D data register BH	ADDRBH	8	H'FF92	A/D	8	2
A/D data register BL	ADDRBL	8	H'FF93	A/D	8	2
A/D data register CH	ADDRCH	8	H'FF94	A/D	8	2
A/D data register CL	ADDRCL	8	H'FF95	A/D	8	2
A/D data register DH	ADDRDH	8	H'FF96	A/D	8	2
A/D data register DL	ADDRDL	8	H'FF97	A/D	8	2
A/D control/status register	ADCSR	8	H'FF98	A/D	8	2
A/D control register	ADCR	8	H'FF99	A/D	8	2
Flash memory control register 1	FLMCR1	8	H'FFA8	ROM	8	2
Flash memory control register 2	FLMCR2	8	H'FFA9	ROM	8	2
Erase block register 1	EBR1	8	H'FFAA	ROM	8	2
Erase block register 2	EBR2	8	H'FFAB	ROM	8	2
Port 1 register	PORT1	8	H'FFB0	PORT	8	2
Port 3 register	PORT3	8	H'FFB2	PORT	8	2
Port 4 register	PORT4	8	H'FFB3	PORT	8	2
Port 7 register	PORT7	8	H'FFB6	PORT	8	2

Register Name	Abbreviation	Number of Bits	Address*	Module	Data Width	Access State
Port 9 register	PORT9	8	H'FFB8	PORT	8	2
Port A register	PORTA	8	H'FFB9	PORT	8	2
Port B register	PORTB	8	H'FFBA	PORT	8	2
Port C register	PORTC	8	H'FFBB	PORT	8	2
Port D register	PORTD	8	H'FFBC	PORT	8	2
Port F register	PORTF	8	H'FFBE	PORT	8	2

Note: * Lower 16 bits of the address.

22.2 Register Bits

The bit names of the registers in the on-chip peripheral modules are listed below. The 16-bit register is indicated in two rows, 8 bits for each row.

Abbreviation	Bit 7	Bit 6	Bit 5	Bit 4	Bit 3	Bit 2	Bit 1	Bit 0	Module
MCR	MCR7	—	MCR5	—	—	MCR2	MCR1	MCR0	HCAN
GSR	—	—	—	—	GSR3	GSR2	GSR1	GSR0	
BCR	BCR7	BCR6	BCR5	BCR4	BCR3	BCR2	BCR1	BCR0	
	BCR15	BCR14	BCR13	BCR12	BCR11	BCR10	BCR9	BCR8	
MBCR	MBCR7	MBCR6	MBCR5	MBCR4	MBCR3	MBCR2	MBCR1	—	
	MBCR15	MBCR14	MBCR13	MBCR12	MBCR11	MBCR10	MBCR9	MBCR8	
TXPR	TXPR7	TXPR6	TXPR5	TXPR4	TXPR3	TXPR2	TXPR1	—	
	TXPR15	TXPR14	TXPR13	TXPR12	TXPR11	TXPR10	TXPR9	TXPR8	
TXCR	TXCR7	TXCR6	TXCR5	TXCR4	TXCR3	TXCR2	TXCR1	—	
	TXCR15	TXCR14	TXCR13	TXCR12	TXCR11	TXCR10	TXCR9	TXCR8	
TXACK	TXACK7	TXACK6	TXACK5	TXACK4	TXACK3	TXACK2	TXACK1	—	
	TXACK15	TXACK14	TXACK13	TXACK12	TXACK11	TXACK10	TXACK9	TXACK8	
ABACK	ABACK7	ABACK6	ABACK5	ABACK4	ABACK3	ABACK2	ABACK1	—	
	ABACK15	ABACK14	ABACK13	ABACK12	ABACK11	ABACK10	ABACK9	ABACK8	
RXPR	RXPR7	RXPR6	RXPR5	RXPR4	RXPR3	RXPR2	RXPR1	RXPR0	
	RXPR15	RXPR14	RXPR13	RXPR12	RXPR11	RXPR10	RXPR9	RXPR8	
RFPR	RFPR7	RFPR6	RFPR5	RFPR4	RFPR3	RFPR2	RFPR1	RFPR0	
	RFPR15	RFPR14	RFPR13	RFPR12	RFPR11	RFPR10	RFPR9	RFPR8	
IRR	IRR7	IRR6	IRR5	IRR4	IRR3	IRR2	IRR1	IRR0	
	—	—	—	IRR12	—	—	IRR9	IRR8	
MBIMR	MBIMR7	MBIMR6	MBIMR5	MBIMR4	MBIMR3	MBIMR2	MBIMR1	MBIMR0	
	MBIMR15	MBIMR14	MBIMR13	MBIMR12	MBIMR11	MBIMR10	MBIMR9	MBIMR8	
IMR	IMR7	IMR6	IMR5	IMR4	IMR3	IMR2	IMR1	—	
	—	—	—	IMR12	—	—	IMR9	IMR8	
REC	Bit 7	Bit 6	Bit 5	Bit 4	Bit 3	Bit 2	Bit 1	Bit 0	
TEC	Bit 7	Bit 6	Bit 5	Bit 4	Bit 3	Bit 2	Bit 1	Bit 0	

Abbrevia- tion	Bit 7	Bit 6	Bit 5	Bit 4	Bit 3	Bit 2	Bit 1	Bit 0	Module
UMSR	UMSR7	UMSR6	UMSR5	UMSR4	UMSR3	UMSR2	UMSR1	UMSR0	HCAN
	UMSR15	UMSR14	UMSR13	UMSR12	UMSR11	UMSR10	UMSR9	UMSR8	
LAFML	LAFML7	LAFML6	LAFML5	LAFML4	LAFML3	LAFML2	LAFML1	LAFML0	
	LAFML15	LAFML14	LAFML13	LAFML12	LAFML11	LAFML10	LAFML9	LAFML8	
LAFMH	LAFMH7	LAFMH6	LAFMH5	—	—	—	LAFMH1	LAFMH0	
	LAFMH15	LAFMH14	LAFMH13	LAFMH12	LAFMH11	LAFMH10	LAFMH9	LAFMH8	
MC0[1]	—	—	—	—	DLC3	DLC2	DLC1	DLC0	
MC0[2]	—	—	—	—	—	—	—	—	
MC0[3]	—	—	—	—	—	—	—	—	
MC0[4]	—	—	—	—	—	—	—	—	
MC0[5]	ID-20	ID-19	ID-18	RTR	IDE	—	ID-17	ID-16	
MC0[6]	ID-28	ID-27	ID-26	ID-25	ID-24	ID-23	ID-22	ID-21	
MC0[7]	ID-7	ID-6	ID-5	ID-4	ID-3	ID-2	ID-1	ID-0	
MC0[8]	ID-15	ID-14	ID-13	ID-12	ID-11	ID-10	ID-9	ID-8	
MC1[1]	—	—	—	—	DLC3	DLC2	DLC1	DLC0	
MC1[2]	—	—	—	—	—	—	—	—	
MC1[3]	—	—	—	—	—	—	—	—	
MC1[4]	—	—	—	—	—	—	—	—	
MC1[5]	ID-20	ID-19	ID-18	RTR	IDE	—	ID-17	ID-16	
MC1[6]	ID-28	ID-27	ID-26	ID-25	ID-24	ID-23	ID-22	ID-21	
MC1[7]	ID-7	ID-6	ID-5	ID-4	ID-3	ID-2	ID-1	ID-0	
MC1[8]	ID-15	ID-14	ID-13	ID-12	ID-11	ID-10	ID-9	ID-8	
MC2[1]	—	—	—	—	DLC3	DLC2	DLC1	DLC0	
MC2[2]	—	—	—	—	—	—	—	—	
MC2[3]	—	—	—	—	—	—	—	—	
MC2[4]	—	—	—	—	—	—	—	—	
MC2[5]	ID-20	ID-19	ID-18	RTR	IDE	—	ID-17	ID-16	
MC2[6]	ID-28	ID-27	ID-26	ID-25	ID-24	ID-23	ID-22	ID-21	
MC2[7]	ID-7	ID-6	ID-5	ID-4	ID-3	ID-2	ID-1	ID-0	
MC2[8]	ID-15	ID-14	ID-13	ID-12	ID-11	ID-10	ID-9	ID-8	

Abbrevia- tion	Bit 7	Bit 6	Bit 5	Bit 4	Bit 3	Bit 2	Bit 1	Bit 0	Module
MC3[1]	—	—	—	—	DLC3	DLC2	DLC1	DLC0	HCAN
MC3[2]	—	—	—	—	—	—	—	—	
MC3[3]	—	—	—	—	—	—	—	—	
MC3[4]	—	—	—	—	—	—	—	—	
MC3[5]	ID-20	ID-19	ID-18	RTR	IDE	—	ID-17	ID-16	
MC3[6]	ID-28	ID-27	ID-26	ID-25	ID-24	ID-23	ID-22	ID-21	
MC3[7]	ID-7	ID-6	ID-5	ID-4	ID-3	ID-2	ID-1	ID-0	
MC3[8]	ID-15	ID-14	ID-13	ID-12	ID-11	ID-10	ID-9	ID-8	
MC4[1]	—	—	—	—	DLC3	DLC2	DLC1	DLC0	
MC4[2]	—	—	—	—	—	—	—	—	
MC4[3]	—	—	—	—	—	—	—	—	
MC4[4]	—	—	—	—	—	—	—	—	
MC4[5]	ID-20	ID-19	ID-18	RTR	IDE	—	ID-17	ID-16	
MC4[6]	ID-28	ID-27	ID-26	ID-25	ID-24	ID-23	ID-22	ID-21	
MC4[7]	ID-7	ID-6	ID-5	ID-4	ID-3	ID-2	ID-1	ID-0	
MC4[8]	ID-15	ID-14	ID-13	ID-12	ID-11	ID-10	ID-9	ID-8	
MC5[1]	—	—	—	—	DLC3	DLC2	DLC1	DLC0	
MC5[2]	—	—	—	—	—	—	—	—	
MC5[3]	—	—	—	—	—	—	—	—	
MC5[4]	—	—	—	—	—	—	—	—	
MC5[5]	ID-20	ID-19	ID-18	RTR	IDE	—	ID-17	ID-16	
MC5[6]	ID-28	ID-27	ID-26	ID-25	ID-24	ID-23	ID-22	ID-21	
MC5[7]	ID-7	ID-6	ID-5	ID-4	ID-3	ID-2	ID-1	ID-0	
MC5[8]	ID-15	ID-14	ID-13	ID-12	ID-11	ID-10	ID-9	ID-8	
MC6[1]	—	—	—	—	DLC3	DLC2	DLC1	DLC0	
MC6[2]	—	—	—	—	—	—	—	—	
MC6[3]	—	—	—	—	—	—	—	—	
MC6[4]	—	—	—	—	—	—	—	—	
MC6[5]	ID-20	ID-19	ID-18	RTR	IDE	—	ID-17	ID-16	
MC6[6]	ID-28	ID-27	ID-26	ID-25	ID-24	ID-23	ID-22	ID-21	

Abbrevia- tion	Bit 7	Bit 6	Bit 5	Bit 4	Bit 3	Bit 2	Bit 1	Bit 0	Module
MC6[7]	ID-7	ID-6	ID-5	ID-4	ID-3	ID-2	ID-1	ID-0	HCAN
MC6[8]	ID-15	ID-14	ID-13	ID-12	ID-11	ID-10	ID-9	ID-8	
MC7[1]	—	—	—	—	DLC3	DLC2	DLC1	DLC0	
MC7[2]	—	—	—	—	—	—	—	—	
MC7[3]	—	—	—	—	—	—	—	—	
MC7[4]	—	—	—	—	—	—	—	—	
MC7[5]	ID-20	ID-19	ID-18	RTR	IDE	—	ID-17	ID-16	
MC7[6]	ID-28	ID-27	ID-26	ID-25	ID-24	ID-23	ID-22	ID-21	
MC7[7]	ID-7	ID-6	ID-5	ID-4	ID-3	ID-2	ID-1	ID-0	
MC7[8]	ID-15	ID-14	ID-13	ID-12	ID-11	ID-10	ID-9	ID-8	
MC8[1]	—	—	—	—	DLC3	DLC2	DLC1	DLC0	
MC8[2]	—	—	—	—	—	—	—	—	
MC8[3]	—	—	—	—	—	—	—	—	
MC8[4]	—	—	—	—	—	—	—	—	
MC8[5]	ID-20	ID-19	ID-18	RTR	IDE	—	ID-17	ID-16	
MC8[6]	ID-28	ID-27	ID-26	ID-25	ID-24	ID-23	ID-22	ID-21	
MC8[7]	ID-7	ID-6	ID-5	ID-4	ID-3	ID-2	ID-1	ID-0	
MC8[8]	ID-15	ID-14	ID-13	ID-12	ID-11	ID-10	ID-9	ID-8	
MC9[1]	—	—	—	—	DLC3	DLC2	DLC1	DLC0	
MC9[2]	—	—	—	—	—	—	—	—	
MC9[3]	—	—	—	—	—	—	—	—	
MC9[4]	—	—	—	—	—	—	—	—	
MC9[5]	ID-20	ID-19	ID-18	RTR	IDE	—	ID-17	ID-16	
MC9[6]	ID-28	ID-27	ID-26	ID-25	ID-24	ID-23	ID-22	ID-21	
MC9[7]	ID-7	ID-6	ID-5	ID-4	ID-3	ID-2	ID-1	ID-0	
MC9[8]	ID-15	ID-14	ID-13	ID-12	ID-11	ID-10	ID-9	ID-8	
MC10[1]	—	—	—	—	DLC3	DLC2	DLC1	DLC0	
MC10[2]	—	—	—	—	—	—	—	—	
MC10[3]	—	—	—	—	—	—	—	—	
MC10[4]	—	—	—	—	—	—	—	—	

Abbrevia- tion	Bit 7	Bit 6	Bit 5	Bit 4	Bit 3	Bit 2	Bit 1	Bit 0	Module
MC10[5]	ID-20	ID-19	ID-18	RTR	IDE	—	ID-17	ID-16	HCAN
MC10[6]	ID-28	ID-27	ID-26	ID-25	ID-24	ID-23	ID-22	ID-21	
MC10[7]	ID-7	ID-6	ID-5	ID-4	ID-3	ID-2	ID-1	ID-0	
MC10[8]	ID-15	ID-14	ID-13	ID-12	ID-11	ID-10	ID-9	ID-8	
MC11[1]	—	—	—	—	DLC3	DLC2	DLC1	DLC0	
MC11[2]	—	—	—	—	—	—	—	—	
MC11[3]	—	—	—	—	—	—	—	—	
MC11[4]	—	—	—	—	—	—	—	—	
MC11[5]	ID-20	ID-19	ID-18	RTR	IDE	—	ID-17	ID-16	
MC11[6]	ID-28	ID-27	ID-26	ID-25	ID-24	ID-23	ID-22	ID-21	
MC11[7]	ID-7	ID-6	ID-5	ID-4	ID-3	ID-2	ID-1	ID-0	
MC11[8]	ID-15	ID-14	ID-13	ID-12	ID-11	ID-10	ID-9	ID-8	
MC12[1]	—	—	—	—	DLC3	DLC2	DLC1	DLC0	
MC12[2]	—	—	—	—	—	—	—	—	
MC12[3]	—	—	—	—	—	—	—	—	
MC12[4]	—	—	—	—	—	—	—	—	
MC12[5]	ID-20	ID-19	ID-18	RTR	IDE	—	ID-17	ID-16	
MC12[6]	ID-28	ID-27	ID-26	ID-25	ID-24	ID-23	ID-22	ID-21	
MC12[7]	ID-7	ID-6	ID-5	ID-4	ID-3	ID-2	ID-1	ID-0	
MC12[8]	ID-15	ID-14	ID-13	ID-12	ID-11	ID-10	ID-9	ID-8	
MC13[1]	—	—	—	—	DLC3	DLC2	DLC1	DLC0	
MC13[2]	—	—	—	—	—	—	—	—	
MC13[3]	—	—	—	—	—	—	—	—	
MC13[4]	—	—	—	—	—	—	—	—	
MC13[5]	ID-20	ID-19	ID-18	RTR	IDE	—	ID-17	ID-16	
MC13[6]	ID-28	ID-27	ID-26	ID-25	ID-24	ID-23	ID-22	ID-21	
MC13[7]	ID-7	ID-6	ID-5	ID-4	ID-3	ID-2	ID-1	ID-0	
MC13[8]	ID-15	ID-14	ID-13	ID-12	ID-11	ID-10	ID-9	ID-8	
MC14[1]	—	—	—	—	DLC3	DLC2	DLC1	DLC0	
MC14[2]	—	—	—	—	—	—	—	—	

Abbrevia- tion	Bit 7	Bit 6	Bit 5	Bit 4	Bit 3	Bit 2	Bit 1	Bit 0	Module
MC14[3]	—	—	—	—	—	—	—	—	HCAN
MC14[4]	—	—	—	—	—	—	—	—	
MC14[5]	ID-20	ID-19	ID-18	RTR	IDE	—	ID-17	ID-16	
MC14[6]	ID-28	ID-27	ID-26	ID-25	ID-24	ID-23	ID-22	ID-21	
MC14[7]	ID-7	ID-6	ID-5	ID-4	ID-3	ID-2	ID-1	ID-0	
MC14[8]	ID-15	ID-14	ID-13	ID-12	ID-11	ID-10	ID-9	ID-8	
MC15[1]	—	—	—	—	DLC3	DLC2	DLC1	DLC0	
MC15[2]	—	—	—	—	—	—	—	—	
MC15[3]	—	—	—	—	—	—	—	—	
MC15[4]	—	—	—	—	—	—	—	—	
MC15[5]	ID-20	ID-19	ID-18	RTR	IDE	—	ID-17	ID-16	
MC15[6]	ID-28	ID-27	ID-26	ID-25	ID-24	ID-23	ID-22	ID-21	
MC15[7]	ID-7	ID-6	ID-5	ID-4	ID-3	ID-2	ID-1	ID-0	
MC15[8]	ID-15	ID-14	ID-13	ID-12	ID-11	ID-10	ID-9	ID-8	
MD0[1]	Bit 7	Bit 6	Bit 5	Bit 4	Bit 3	Bit 2	Bit 1	Bit 0	
MD0[2]	Bit 7	Bit 6	Bit 5	Bit 4	Bit 3	Bit 2	Bit 1	Bit 0	
MD0[3]	Bit 7	Bit 6	Bit 5	Bit 4	Bit 3	Bit 2	Bit 1	Bit 0	
MD0[4]	Bit 7	Bit 6	Bit 5	Bit 4	Bit 3	Bit 2	Bit 1	Bit 0	
MD0[5]	Bit 7	Bit 6	Bit 5	Bit 4	Bit 3	Bit 2	Bit 1	Bit 0	
MD0[6]	Bit 7	Bit 6	Bit 5	Bit 4	Bit 3	Bit 2	Bit 1	Bit 0	
MD0[7]	Bit 7	Bit 6	Bit 5	Bit 4	Bit 3	Bit 2	Bit 1	Bit 0	
MD0[8]	Bit 7	Bit 6	Bit 5	Bit 4	Bit 3	Bit 2	Bit 1	Bit 0	
MD1[1]	Bit 7	Bit 6	Bit 5	Bit 4	Bit 3	Bit 2	Bit 1	Bit 0	
MD1[2]	Bit 7	Bit 6	Bit 5	Bit 4	Bit 3	Bit 2	Bit 1	Bit 0	
MD1[3]	Bit 7	Bit 6	Bit 5	Bit 4	Bit 3	Bit 2	Bit 1	Bit 0	
MD1[4]	Bit 7	Bit 6	Bit 5	Bit 4	Bit 3	Bit 2	Bit 1	Bit 0	
MD1[5]	Bit 7	Bit 6	Bit 5	Bit 4	Bit 3	Bit 2	Bit 1	Bit 0	
MD1[6]	Bit 7	Bit 6	Bit 5	Bit 4	Bit 3	Bit 2	Bit 1	Bit 0	
MD1[7]	Bit 7	Bit 6	Bit 5	Bit 4	Bit 3	Bit 2	Bit 1	Bit 0	
MD1[8]	Bit 7	Bit 6	Bit 5	Bit 4	Bit 3	Bit 2	Bit 1	Bit 0	

Abbrevia- tion	Bit 7	Bit 6	Bit 5	Bit 4	Bit 3	Bit 2	Bit 1	Bit 0	Module
MD2[1]	Bit 7	Bit 6	Bit 5	Bit 4	Bit 3	Bit 2	Bit 1	Bit 0	HCAN
MD2[2]	Bit 7	Bit 6	Bit 5	Bit 4	Bit 3	Bit 2	Bit 1	Bit 0	
MD2[3]	Bit 7	Bit 6	Bit 5	Bit 4	Bit 3	Bit 2	Bit 1	Bit 0	
MD2[4]	Bit 7	Bit 6	Bit 5	Bit 4	Bit 3	Bit 2	Bit 1	Bit 0	
MD2[5]	Bit 7	Bit 6	Bit 5	Bit 4	Bit 3	Bit 2	Bit 1	Bit 0	
MD2[6]	Bit 7	Bit 6	Bit 5	Bit 4	Bit 3	Bit 2	Bit 1	Bit 0	
MD2[7]	Bit 7	Bit 6	Bit 5	Bit 4	Bit 3	Bit 2	Bit 1	Bit 0	
MD2[8]	Bit 7	Bit 6	Bit 5	Bit 4	Bit 3	Bit 2	Bit 1	Bit 0	
MD3[1]	Bit 7	Bit 6	Bit 5	Bit 4	Bit 3	Bit 2	Bit 1	Bit 0	
MD3[2]	Bit 7	Bit 6	Bit 5	Bit 4	Bit 3	Bit 2	Bit 1	Bit 0	
MD3[3]	Bit 7	Bit 6	Bit 5	Bit 4	Bit 3	Bit 2	Bit 1	Bit 0	
MD3[4]	Bit 7	Bit 6	Bit 5	Bit 4	Bit 3	Bit 2	Bit 1	Bit 0	
MD3[5]	Bit 7	Bit 6	Bit 5	Bit 4	Bit 3	Bit 2	Bit 1	Bit 0	
MD3[6]	Bit 7	Bit 6	Bit 5	Bit 4	Bit 3	Bit 2	Bit 1	Bit 0	
MD3[7]	Bit 7	Bit 6	Bit 5	Bit 4	Bit 3	Bit 2	Bit 1	Bit 0	
MD3[8]	Bit 7	Bit 6	Bit 5	Bit 4	Bit 3	Bit 2	Bit 1	Bit 0	
MD4[1]	Bit 7	Bit 6	Bit 5	Bit 4	Bit 3	Bit 2	Bit 1	Bit 0	
MD4[2]	Bit 7	Bit 6	Bit 5	Bit 4	Bit 3	Bit 2	Bit 1	Bit 0	
MD4[3]	Bit 7	Bit 6	Bit 5	Bit 4	Bit 3	Bit 2	Bit 1	Bit 0	
MD4[4]	Bit 7	Bit 6	Bit 5	Bit 4	Bit 3	Bit 2	Bit 1	Bit 0	
MD4[5]	Bit 7	Bit 6	Bit 5	Bit 4	Bit 3	Bit 2	Bit 1	Bit 0	
MD4[6]	Bit 7	Bit 6	Bit 5	Bit 4	Bit 3	Bit 2	Bit 1	Bit 0	
MD4[7]	Bit 7	Bit 6	Bit 5	Bit 4	Bit 3	Bit 2	Bit 1	Bit 0	
MD4[8]	Bit 7	Bit 6	Bit 5	Bit 4	Bit 3	Bit 2	Bit 1	Bit 0	
MD5[1]	Bit 7	Bit 6	Bit 5	Bit 4	Bit 3	Bit 2	Bit 1	Bit 0	
MD5[2]	Bit 7	Bit 6	Bit 5	Bit 4	Bit 3	Bit 2	Bit 1	Bit 0	
MD5[3]	Bit 7	Bit 6	Bit 5	Bit 4	Bit 3	Bit 2	Bit 1	Bit 0	
MD5[4]	Bit 7	Bit 6	Bit 5	Bit 4	Bit 3	Bit 2	Bit 1	Bit 0	
MD5[5]	Bit 7	Bit 6	Bit 5	Bit 4	Bit 3	Bit 2	Bit 1	Bit 0	
MD5[6]	Bit 7	Bit 6	Bit 5	Bit 4	Bit 3	Bit 2	Bit 1	Bit 0	

Abbrevia- tion	Bit 7	Bit 6	Bit 5	Bit 4	Bit 3	Bit 2	Bit 1	Bit 0	Module
MD5[7]	Bit 7	Bit 6	Bit 5	Bit 4	Bit 3	Bit 2	Bit 1	Bit 0	HCAN
MD5[8]	Bit 7	Bit 6	Bit 5	Bit 4	Bit 3	Bit 2	Bit 1	Bit 0	
MD6[1]	Bit 7	Bit 6	Bit 5	Bit 4	Bit 3	Bit 2	Bit 1	Bit 0	
MD6[2]	Bit 7	Bit 6	Bit 5	Bit 4	Bit 3	Bit 2	Bit 1	Bit 0	
MD6[3]	Bit 7	Bit 6	Bit 5	Bit 4	Bit 3	Bit 2	Bit 1	Bit 0	
MD6[4]	Bit 7	Bit 6	Bit 5	Bit 4	Bit 3	Bit 2	Bit 1	Bit 0	
MD6[5]	Bit 7	Bit 6	Bit 5	Bit 4	Bit 3	Bit 2	Bit 1	Bit 0	
MD6[6]	Bit 7	Bit 6	Bit 5	Bit 4	Bit 3	Bit 2	Bit 1	Bit 0	
MD6[7]	Bit 7	Bit 6	Bit 5	Bit 4	Bit 3	Bit 2	Bit 1	Bit 0	
MD6[8]	Bit 7	Bit 6	Bit 5	Bit 4	Bit 3	Bit 2	Bit 1	Bit 0	
MD7[1]	Bit 7	Bit 6	Bit 5	Bit 4	Bit 3	Bit 2	Bit 1	Bit 0	
MD7[2]	Bit 7	Bit 6	Bit 5	Bit 4	Bit 3	Bit 2	Bit 1	Bit 0	
MD7[3]	Bit 7	Bit 6	Bit 5	Bit 4	Bit 3	Bit 2	Bit 1	Bit 0	
MD7[4]	Bit 7	Bit 6	Bit 5	Bit 4	Bit 3	Bit 2	Bit 1	Bit 0	
MD7[5]	Bit 7	Bit 6	Bit 5	Bit 4	Bit 3	Bit 2	Bit 1	Bit 0	
MD7[6]	Bit 7	Bit 6	Bit 5	Bit 4	Bit 3	Bit 2	Bit 1	Bit 0	
MD7[7]	Bit 7	Bit 6	Bit 5	Bit 4	Bit 3	Bit 2	Bit 1	Bit 0	
MD7[8]	Bit 7	Bit 6	Bit 5	Bit 4	Bit 3	Bit 2	Bit 1	Bit 0	
MD8[1]	Bit 7	Bit 6	Bit 5	Bit 4	Bit 3	Bit 2	Bit 1	Bit 0	
MD8[2]	Bit 7	Bit 6	Bit 5	Bit 4	Bit 3	Bit 2	Bit 1	Bit 0	
MD8[3]	Bit 7	Bit 6	Bit 5	Bit 4	Bit 3	Bit 2	Bit 1	Bit 0	
MD8[4]	Bit 7	Bit 6	Bit 5	Bit 4	Bit 3	Bit 2	Bit 1	Bit 0	
MD8[5]	Bit 7	Bit 6	Bit 5	Bit 4	Bit 3	Bit 2	Bit 1	Bit 0	
MD8[6]	Bit 7	Bit 6	Bit 5	Bit 4	Bit 3	Bit 2	Bit 1	Bit 0	
MD8[7]	Bit 7	Bit 6	Bit 5	Bit 4	Bit 3	Bit 2	Bit 1	Bit 0	
MD8[8]	Bit 7	Bit 6	Bit 5	Bit 4	Bit 3	Bit 2	Bit 1	Bit 0	
MD9[1]	Bit 7	Bit 6	Bit 5	Bit 4	Bit 3	Bit 2	Bit 1	Bit 0	
MD9[2]	Bit 7	Bit 6	Bit 5	Bit 4	Bit 3	Bit 2	Bit 1	Bit 0	
MD9[3]	Bit 7	Bit 6	Bit 5	Bit 4	Bit 3	Bit 2	Bit 1	Bit 0	
MD9[4]	Bit 7	Bit 6	Bit 5	Bit 4	Bit 3	Bit 2	Bit 1	Bit 0	

Abbrevia- tion	Bit 7	Bit 6	Bit 5	Bit 4	Bit 3	Bit 2	Bit 1	Bit 0	Module
MD9[5]	Bit 7	Bit 6	Bit 5	Bit 4	Bit 3	Bit 2	Bit 1	Bit 0	HCAN
MD9[6]	Bit 7	Bit 6	Bit 5	Bit 4	Bit 3	Bit 2	Bit 1	Bit 0	
MD9[7]	Bit 7	Bit 6	Bit 5	Bit 4	Bit 3	Bit 2	Bit 1	Bit 0	
MD9[8]	Bit 7	Bit 6	Bit 5	Bit 4	Bit 3	Bit 2	Bit 1	Bit 0	
MD10[1]	Bit 7	Bit 6	Bit 5	Bit 4	Bit 3	Bit 2	Bit 1	Bit 0	
MD10[2]	Bit 7	Bit 6	Bit 5	Bit 4	Bit 3	Bit 2	Bit 1	Bit 0	
MD10[3]	Bit 7	Bit 6	Bit 5	Bit 4	Bit 3	Bit 2	Bit 1	Bit 0	
MD10[4]	Bit 7	Bit 6	Bit 5	Bit 4	Bit 3	Bit 2	Bit 1	Bit 0	
MD10[5]	Bit 7	Bit 6	Bit 5	Bit 4	Bit 3	Bit 2	Bit 1	Bit 0	
MD10[6]	Bit 7	Bit 6	Bit 5	Bit 4	Bit 3	Bit 2	Bit 1	Bit 0	
MD10[7]	Bit 7	Bit 6	Bit 5	Bit 4	Bit 3	Bit 2	Bit 1	Bit 0	
MD10[8]	Bit 7	Bit 6	Bit 5	Bit 4	Bit 3	Bit 2	Bit 1	Bit 0	
MD11[1]	Bit 7	Bit 6	Bit 5	Bit 4	Bit 3	Bit 2	Bit 1	Bit 0	
MD11[2]	Bit 7	Bit 6	Bit 5	Bit 4	Bit 3	Bit 2	Bit 1	Bit 0	
MD11[3]	Bit 7	Bit 6	Bit 5	Bit 4	Bit 3	Bit 2	Bit 1	Bit 0	
MD11[4]	Bit 7	Bit 6	Bit 5	Bit 4	Bit 3	Bit 2	Bit 1	Bit 0	
MD11[5]	Bit 7	Bit 6	Bit 5	Bit 4	Bit 3	Bit 2	Bit 1	Bit 0	
MD11[6]	Bit 7	Bit 6	Bit 5	Bit 4	Bit 3	Bit 2	Bit 1	Bit 0	
MD11[7]	Bit 7	Bit 6	Bit 5	Bit 4	Bit 3	Bit 2	Bit 1	Bit 0	
MD11[8]	Bit 7	Bit 6	Bit 5	Bit 4	Bit 3	Bit 2	Bit 1	Bit 0	
MD12[1]	Bit 7	Bit 6	Bit 5	Bit 4	Bit 3	Bit 2	Bit 1	Bit 0	
MD12[2]	Bit 7	Bit 6	Bit 5	Bit 4	Bit 3	Bit 2	Bit 1	Bit 0	
MD12[3]	Bit 7	Bit 6	Bit 5	Bit 4	Bit 3	Bit 2	Bit 1	Bit 0	
MD12[4]	Bit 7	Bit 6	Bit 5	Bit 4	Bit 3	Bit 2	Bit 1	Bit 0	
MD12[5]	Bit 7	Bit 6	Bit 5	Bit 4	Bit 3	Bit 2	Bit 1	Bit 0	
MD12[6]	Bit 7	Bit 6	Bit 5	Bit 4	Bit 3	Bit 2	Bit 1	Bit 0	
MD12[7]	Bit 7	Bit 6	Bit 5	Bit 4	Bit 3	Bit 2	Bit 1	Bit 0	
MD12[8]	Bit 7	Bit 6	Bit 5	Bit 4	Bit 3	Bit 2	Bit 1	Bit 0	
MD13[1]	Bit 7	Bit 6	Bit 5	Bit 4	Bit 3	Bit 2	Bit 1	Bit 0	
MD13[2]	Bit 7	Bit 6	Bit 5	Bit 4	Bit 3	Bit 2	Bit 1	Bit 0	

Abbrevia- tion	Bit 7	Bit 6	Bit 5	Bit 4	Bit 3	Bit 2	Bit 1	Bit 0	Module
MD13[3]	Bit 7	Bit 6	Bit 5	Bit 4	Bit 3	Bit 2	Bit 1	Bit 0	HCAN
MD13[4]	Bit 7	Bit 6	Bit 5	Bit 4	Bit 3	Bit 2	Bit 1	Bit 0	
MD13[5]	Bit 7	Bit 6	Bit 5	Bit 4	Bit 3	Bit 2	Bit 1	Bit 0	
MD13[6]	Bit 7	Bit 6	Bit 5	Bit 4	Bit 3	Bit 2	Bit 1	Bit 0	
MD13[7]	Bit 7	Bit 6	Bit 5	Bit 4	Bit 3	Bit 2	Bit 1	Bit 0	
MD13[8]	Bit 7	Bit 6	Bit 5	Bit 4	Bit 3	Bit 2	Bit 1	Bit 0	
MD14[1]	Bit 7	Bit 6	Bit 5	Bit 4	Bit 3	Bit 2	Bit 1	Bit 0	
MD14[2]	Bit 7	Bit 6	Bit 5	Bit 4	Bit 3	Bit 2	Bit 1	Bit 0	
MD14[3]	Bit 7	Bit 6	Bit 5	Bit 4	Bit 3	Bit 2	Bit 1	Bit 0	
MD14[4]	Bit 7	Bit 6	Bit 5	Bit 4	Bit 3	Bit 2	Bit 1	Bit 0	
MD14[5]	Bit 7	Bit 6	Bit 5	Bit 4	Bit 3	Bit 2	Bit 1	Bit 0	
MD14[6]	Bit 7	Bit 6	Bit 5	Bit 4	Bit 3	Bit 2	Bit 1	Bit 0	
MD14[7]	Bit 7	Bit 6	Bit 5	Bit 4	Bit 3	Bit 2	Bit 1	Bit 0	
MD14[8]	Bit 7	Bit 6	Bit 5	Bit 4	Bit 3	Bit 2	Bit 1	Bit 0	
MD15[1]	Bit 7	Bit 6	Bit 5	Bit 4	Bit 3	Bit 2	Bit 1	Bit 0	
MD15[2]	Bit 7	Bit 6	Bit 5	Bit 4	Bit 3	Bit 2	Bit 1	Bit 0	
MD15[3]	Bit 7	Bit 6	Bit 5	Bit 4	Bit 3	Bit 2	Bit 1	Bit 0	
MD15[4]	Bit 7	Bit 6	Bit 5	Bit 4	Bit 3	Bit 2	Bit 1	Bit 0	
MD15[5]	Bit 7	Bit 6	Bit 5	Bit 4	Bit 3	Bit 2	Bit 1	Bit 0	
MD15[6]	Bit 7	Bit 6	Bit 5	Bit 4	Bit 3	Bit 2	Bit 1	Bit 0	
MD15[7]	Bit 7	Bit 6	Bit 5	Bit 4	Bit 3	Bit 2	Bit 1	Bit 0	
MD15[8]	Bit 7	Bit 6	Bit 5	Bit 4	Bit 3	Bit 2	Bit 1	Bit 0	
HCAN MON	RXDIE	TxSTP	—	—	—	—	TxD	RxD	

Abbrevia- tion	Bit 7	Bit 6	Bit 5	Bit 4	Bit 3	Bit 2	Bit 1	Bit 0	Module
SSCRH _0	MSS	BIDE	—	SOL	SOLP	SCKS	CSS1	CSS0	SSU_0
SSCRL _0	—	—	SRES	—	—	—	DATS1	DATS0	
SSMR _0	MLS	CPOS	CPHS	—	—	CKS2	CKS1	CKS0	
SSER _0	TE	RE	—	—	TEIE	TIE	RIE	CEIE	
SSSR _0	—	ORER	—	—	TEND	TDRE	RDRF	CE	
SSTDR0 _0	Bit 7	Bit 6	Bit 5	Bit 4	Bit 3	Bit 2	Bit 1	Bit 0	
SSTDR1 _0	Bit 7	Bit 6	Bit 5	Bit 4	Bit 3	Bit 2	Bit 1	Bit 0	
SSTDR2 _0	Bit 7	Bit 6	Bit 5	Bit 4	Bit 3	Bit 2	Bit 1	Bit 0	
SSTDR3 _0	Bit 7	Bit 6	Bit 5	Bit 4	Bit 3	Bit 2	Bit 1	Bit 0	
SSRDR0 _0	Bit 7	Bit 6	Bit 5	Bit 4	Bit 3	Bit 2	Bit 1	Bit 0	
SSRDR1 _0	Bit 7	Bit 6	Bit 5	Bit 4	Bit 3	Bit 2	Bit 1	Bit 0	
SSRDR2 _0	Bit 7	Bit 6	Bit 5	Bit 4	Bit 3	Bit 2	Bit 1	Bit 0	
SSRDR3 _0	Bit 7	Bit 6	Bit 5	Bit 4	Bit 3	Bit 2	Bit 1	Bit 0	

Abbrevia- tion	Bit 7	Bit 6	Bit 5	Bit 4	Bit 3	Bit 2	Bit 1	Bit 0	Module
SSCRH _1	MSS	BIDE	—	SOL	SOLP	SCKS	CSS1	CSS0	SSU_1
SSCRL _1	—	—	SRES	—	—	—	DATS1	DATS0	
SSMR_1	MLS	CPOS	CPHS	—	—	CKS2	CKS1	CKS0	
SSER_1	TE	RE	—	—	TEIE	TIE	RIE	CEIE	
SSSR_1	—	ORER	—	—	TEND	TDRE	RDRF	CE	
SSTDR0 _1	Bit 7	Bit 6	Bit 5	Bit 4	Bit 3	Bit 2	Bit 1	Bit 0	
SSTDR1 _1	Bit 7	Bit 6	Bit 5	Bit 4	Bit 3	Bit 2	Bit 1	Bit 0	
SSTDR2 _1	Bit 7	Bit 6	Bit 5	Bit 4	Bit 3	Bit 2	Bit 1	Bit 0	
SSTDR3 _1	Bit 7	Bit 6	Bit 5	Bit 4	Bit 3	Bit 2	Bit 1	Bit 0	
SSRDR0 _1	Bit 7	Bit 6	Bit 5	Bit 4	Bit 3	Bit 2	Bit 1	Bit 0	
SSRDR1 _1	Bit 7	Bit 6	Bit 5	Bit 4	Bit 3	Bit 2	Bit 1	Bit 0	
SSRDR2 _1	Bit 7	Bit 6	Bit 5	Bit 4	Bit 3	Bit 2	Bit 1	Bit 0	
SSRDR3 _1	Bit 7	Bit 6	Bit 5	Bit 4	Bit 3	Bit 2	Bit 1	Bit 0	
PDRTIDR	Bit 7	Bit 6	Bit 5	Bit 4	Bit 3	Bit 2	Bit 1	Bit 0	PORT
TCR_2	CMIEB	CMIEA	OVIE	CCLR1	CCLR0	CKS2	CKS1	CKS0	TMR_2,
TCR_3	CMIEB	CMIEA	OVIE	CCLR1	CCLR0	CKS2	CKS1	CKS0	TMR_3
TCSR_2	CMFB	CMFA	OVF	ADTE	OS3	OS2	OS1	OS0	
TCSR_3	CMFB	CMFA	OVF	—	OS3	OS2	OS1	OS0	
TCORA _2	Bit 7	Bit 6	Bit 5	Bit 4	Bit 3	Bit 2	Bit 1	Bit 0	
TCORA _3	Bit 7	Bit 6	Bit 5	Bit 4	Bit 3	Bit 2	Bit 1	Bit 0	

Abbrevia- tion	Bit 7	Bit 6	Bit 5	Bit 4	Bit 3	Bit 2	Bit 1	Bit 0	Module
TCORB _2	Bit 7	Bit 6	Bit 5	Bit 4	Bit 3	Bit 2	Bit 1	Bit 0	TMR_2, TMR_3
TCORB _3	Bit 7	Bit 6	Bit 5	Bit 4	Bit 3	Bit 2	Bit 1	Bit 0	
TCNT_2	Bit 7	Bit 6	Bit 5	Bit 4	Bit 3	Bit 2	Bit 1	Bit 0	
TCNT_3	Bit 7	Bit 6	Bit 5	Bit 4	Bit 3	Bit 2	Bit 1	Bit 0	
SBYCR	SSBY	STS2	STS1	STS0	—	—	—	—	SYSTEM
SYSCR	MACS	—	INTM1	INTM0	NMIEG	—	—	RAME	
SCKCR	PSTOP	—	—	—	STCS	SCK2	SCK1	SCK0	
MDCR	—	—	—	—	—	MDS2	MDS1	MDS0	
MSTP CRA	MSTPA7	MSTPA6	MSTPA5	MSTPA4	MSTPA3	MSTPA2	MSTPA1	MSTPA0	
MSTP CRB	MSTPB7	MSTPB6	MSTPB5	MSTPB4	MSTPB3	MSTPB2	MSTPB1	MSTPB0	
MSTP CRC	MSTPC7	MSTPC6	MSTPC5	MSTPC4	MSTPC3	MSTPC2	MSTPC1	MSTPC0	
LPWR CR	—	—	—	—	—	—	STC1	STC0	
BARA	—	—	—	—	—	—	—	—	PBC
	BAA23	BAA22	BAA21	BAA20	BAA19	BAA18	BAA17	BAA16	
	BAA15	BAA14	BAA13	BAA12	BAA11	BAA10	BAA9	BAA8	
	BAA7	BAA6	BAA5	BAA4	BAA3	BAA2	BAA1	BAA0	
BARB	—	—	—	—	—	—	—	—	
	BAB23	BAB22	BAB21	BAB20	BAB19	BAB18	BAB17	BAB16	
	BAB15	BAB14	BAB13	BAB12	BAB11	BAB10	BAB9	BAB8	
	BAB7	BAB6	BAB5	BAB4	BAB3	BAB2	BAB1	BAB0	
BCRA	CMFA	CDA	BAMRA2	BAMRA1	BAMRA0	CSELA1	CSELA0	BIEA	
BCRB	CMFB	CDB	BAMRB2	BAMRB1	BAMRB0	CSELB1	CSELB0	BIEB	
ISCRH	—	—	—	—	IRQ5SCB	IRQ5SCA	IRQ4SCB	IRQ4SCA	INT
ISCR L	IRQ3SCB	IRQ3SCA	IRQ2SCB	IRQ2SCA	IRQ1SCB	IRQ1SCA	IRQ0SCB	IRQ0SCA	
IER	—	—	IRQ5E	IRQ4E	IRQ3E	IRQ2E	IRQ1E	IRQ0E	
ISR	—	—	IRQ5F	IRQ4F	IRQ3F	IRQ2F	IRQ1F	IRQ0F	

Abbrevia- tion	Bit 7	Bit 6	Bit 5	Bit 4	Bit 3	Bit 2	Bit 1	Bit 0	Module
DTCERA	DTCEA7	DTCEA6	DTCEA5	DTCEA4	DTCEA3	DTCEA2	DTCEA1	DTCEA0	DTC
DTCERB	DTCEB7	DTCEB6	DTCEB5	DTCEB4	DTCEB3	DTCEB2	DTCEB1	DTCEB0	
DTCERC	DTCEC7	DTCEC6	DTCEC5	DTCEC4	DTCEC3	DTCEC2	DTCEC1	DTCEC0	
DTCERD	DTCED7	DTCED6	DTCED5	DTCED4	DTCED3	DTCED2	DTCED1	DTCED0	
DTCERE	DTCEE7	DTCEE6	DTCEE5	DTCEE4	DTCEE3	DTCEE2	DTCEE1	DTCEE0	
DTCERF	DTCEF7	DTCEF6	DTCEF5	DTCEF4	DTCEF3	DTCEF2	DTCEF1	DTCEF0	
DTCERG	DTCEG7	DTCEG6	DTCEG5	DTCEG4	DTCEG3	DTCEG2	DTCEG1	DTCEG0	
DTVECR	SWDTE	DTVEC6	DTVEC5	DTVEC4	DTVEC3	DTVEC2	DTVEC1	DTVEC0	
PCR	G3CMS1	G3CMS0	G2CMS1	G2CMS0	G1CMS1	G1CMS0	G0CMS1	G0CMS0	PPG
PMR	G3INV	G2INV	—	—	G3NOV	G2NOV	—	—	
NDERH	NDER15	NDER14	NDER13	NDER12	NDER11	NDER10	NDER9	NDER8	
NDERL	NDER7	NDER6	NDER5	NDER4	NDER3	NDER2	NDER1	NDER0	
PODRH	POD15	POD14	POD13	POD12	POD11	POD10	POD9	POD8	
PODRL	POD7	POD6	POD5	POD4	POD3	POD2	POD1	POD0	
NDRH	NDR15	NDR14	NDR13	NDR12	NDR11	NDR10	NDR9	NDR8	
NDRL	NDR7	NDR6	NDR5	NDR4	NDR3	NDR2	NDR1	NDR0	
NDRH	—	—	—	—	NDR11	NDR10	NDR9	NDR8	
NDRL	—	—	—	—	NDR3	NDR2	NDR1	NDR0	
P1DDR	P17DDR	P16DDR	P15DDR	P14DDR	P13DDR	P12DDR	P11DDR	P10DDR	PORT
P3DDR	P37DDR	P36DDR	P35DDR	P34DDR	P33DDR	P32DDR	P31DDR	P30DDR	
P7DDR	P77DDR	P76DDR	P75DDR	P74DDR	P73DDR	P72DDR	P71DDR	P70DDR	
PADDR	—	—	—	—	PA3DDR	PA2DDR	PA1DDR	PA0DDR	
PBDDR	PB7DDR	PB6DDR	PB5DDR	PB4DDR	PB3DDR	PB2DDR	PB1DDR	PB0DDR	
PCDDR	PC7DDR	PC6DDR	PC5DDR	PC4DDR	PC3DDR	PC2DDR	PC1DDR	PC0DDR	
PDDDR	PD7DDR	PD6DDR	PD5DDR	PD4DDR	PD3DDR	PD2DDR	PD1DDR	PD0DDR	
PFDDR	PF7DDR	PF6DDR	PF5DDR	PF4DDR	PF3DDR	PF2DDR	PF1DDR	PF0DDR	
PAPCR	—	—	—	—	PA3PCR	PA2PCR	PA1PCR	PA0PCR	
PBPCR	PB7PCR	PB6PCR	PB5PCR	PB4PCR	PB3PCR	PB2PCR	PB1PCR	PB0PCR	
PCPCR	PC7PCR	PC6PCR	PC5PCR	PC4PCR	PC3PCR	PC2PCR	PC1PCR	PC0PCR	
PDPCR	PD7PCR	PD6PCR	PD5PCR	PD4PCR	PD3PCR	PD2PCR	PD1PCR	PD0PCR	

Abbrevia- tion	Bit 7	Bit 6	Bit 5	Bit 4	Bit 3	Bit 2	Bit 1	Bit 0	Module
P3ODR	P37ODR	P36ODR	P35ODR	P34ODR	P33ODR	P32ODR	P31ODR	P30ODR	PORT
PAODR	—	—	—	—	PA3ODR	PA2ODR	PA1ODR	PA0ODR	
PBODR	PB7ODR	PB6ODR	PB5ODR	PB4ODR	PB3ODR	PB2ODR	PB1ODR	PB0ODR	
PCODR	PC7ODR	PC6ODR	PC5ODR	PC4ODR	PC3ODR	PC2ODR	PC1ODR	PC0ODR	
TCR_3	CCLR2	CCLR1	CCLR0	CKEG1	CKEG0	TPSC2	TPSC1	TPSC0	TPU_3
TMDR_3	—	—	BFB	BFA	MD3	MD2	MD1	MD0	
TIORH_3	IOB3	IOB2	IOB1	IOB0	IOA3	IOA2	IOA1	IOA0	
TIORL_3	IOD3	IOD2	IOD1	IOD0	IOC3	IOC2	IOC1	IOC0	
TIER_3	TTGE	—	—	TCIEV	TGIED	TGIEC	TGIEB	TGIEA	
TSR_3	—	—	—	TCFV	TGFD	TGFC	TGFB	TGFA	
TCNTH_3	Bit 15	Bit 14	Bit 13	Bit 12	Bit 11	Bit 10	Bit 9	Bit 8	
TCNTL_3	Bit 7	Bit 6	Bit 5	Bit 4	Bit 3	Bit 2	Bit 1	Bit 0	
TGRAH_3	Bit 15	Bit 14	Bit 13	Bit 12	Bit 11	Bit 10	Bit 9	Bit 8	
TGRAL_3	Bit 7	Bit 6	Bit 5	Bit 4	Bit 3	Bit 2	Bit 1	Bit 0	
TGRBH_3	Bit 15	Bit 14	Bit 13	Bit 12	Bit 11	Bit 10	Bit 9	Bit 8	
TGRBL_3	Bit 7	Bit 6	Bit 5	Bit 4	Bit 3	Bit 2	Bit 1	Bit 0	
TGRCH_3	Bit 15	Bit 14	Bit 13	Bit 12	Bit 11	Bit 10	Bit 9	Bit 8	
TGRCL_3	Bit 7	Bit 6	Bit 5	Bit 4	Bit 3	Bit 2	Bit 1	Bit 0	
TGRDH_3	Bit 15	Bit 14	Bit 13	Bit 12	Bit 11	Bit 10	Bit 9	Bit 8	
TGRDL_3	Bit 7	Bit 6	Bit 5	Bit 4	Bit 3	Bit 2	Bit 1	Bit 0	
TCR_4	—	CCLR1	CCLR0	CKEG1	CKEG0	TPSC2	TPSC1	TPSC0	TPU_4
TMDR_4	—	—	—	—	MD3	MD2	MD1	MD0	
TIOR_4	IOB3	IOB2	IOB1	IOB0	IOA3	IOA2	IOA1	IOA0	
TIER_4	TTGE	—	TCIEU	TCIEV	—	—	TGIEB	TGIEA	
TSR_4	TCFD	—	TCFU	TCFV	—	—	TGFB	TGFA	
TCNTH_4	Bit 15	Bit 14	Bit 13	Bit 12	Bit 11	Bit 10	Bit 9	Bit 8	
TCNTL_4	Bit 7	Bit 6	Bit 5	Bit 4	Bit 3	Bit 2	Bit 1	Bit 0	
TGRAH_4	Bit 15	Bit 14	Bit 13	Bit 12	Bit 11	Bit 10	Bit 9	Bit 8	
TGRAL_4	Bit 7	Bit 6	Bit 5	Bit 4	Bit 3	Bit 2	Bit 1	Bit 0	
TGRBH_4	Bit 15	Bit 14	Bit 13	Bit 12	Bit 11	Bit 10	Bit 9	Bit 8	
TGRBL_4	Bit 7	Bit 6	Bit 5	Bit 4	Bit 3	Bit 2	Bit 1	Bit 0	

Abbrevia- tion	Bit 7	Bit 6	Bit 5	Bit 4	Bit 3	Bit 2	Bit 1	Bit 0	Module
TCR_5	—	CCLR1	CCLR0	CKEG1	CKEG0	TPSC2	TPSC1	TPSC0	TPU_5
TMDR_5	—	—	—	—	MD3	MD2	MD1	MD0	
TIOR_5	IOB3	IOB2	IOB1	IOB0	IOA3	IOA2	IOA1	IOA0	
TIER_5	TTGE	—	TCIEU	TCIEV	—	—	TGIEB	TGIEA	
TSR_5	TCFD	—	TCFU	TCFV	—	—	TGFB	TGFA	
TCNTH_5	Bit 15	Bit 14	Bit 13	Bit 12	Bit 11	Bit 10	Bit 9	Bit 8	
TCNTL_5	Bit 7	Bit 6	Bit 5	Bit 4	Bit 3	Bit 2	Bit 1	Bit 0	
TGRAH_5	Bit 15	Bit 14	Bit 13	Bit 12	Bit 11	Bit 10	Bit 9	Bit 8	
TGRAL_5	Bit 7	Bit 6	Bit 5	Bit 4	Bit 3	Bit 2	Bit 1	Bit 0	
TGRBH_5	Bit 15	Bit 14	Bit 13	Bit 12	Bit 11	Bit 10	Bit 9	Bit 8	
TGRBL_5	Bit 7	Bit 6	Bit 5	Bit 4	Bit 3	Bit 2	Bit 1	Bit 0	
TSTR	—	—	CST5	CST4	CST3	CST2	CST1	CST0	TPU common
TSYR	—	—	SYNC5	SYNC4	SYNC3	SYNC2	SYNC1	SYNC0	
IPRA	—	IPR6	IPR5	IPR4	—	IPR2	IPR1	IPR0	INT
IPRB	—	IPR6	IPR5	IPR4	—	IPR2	IPR1	IPR0	
IPRC	—	IPR6	IPR5	IPR4	—	IPR2	IPR1	IPR0	
IPRD	—	IPR6	IPR5	IPR4	—	IPR2	IPR1	IPR0	
IPRE	—	IPR6	IPR5	IPR4	—	IPR2	IPR1	IPR0	
IPRF	—	IPR6	IPR5	IPR4	—	IPR2	IPR1	IPR0	
IPRG	—	IPR6	IPR5	IPR4	—	IPR2	IPR1	IPR0	
IPRH	—	IPR6	IPR5	IPR4	—	IPR2	IPR1	IPR0	
IPRJ	—	IPR6	IPR5	IPR4	—	IPR2	IPR1	IPR0	
IPRK	—	IPR6	IPR5	IPR4	—	IPR2	IPR1	IPR0	
IPRM	—	IPR6	IPR5	IPR4	—	IPR2	IPR1	IPR0	
RAMER	—	—	—	—	RAMS	RAM2	RAM1	RAM0	FLASH (F-ZTAT Version)
P1DR	P17DR	P16DR	P15DR	P14DR	P13DR	P12DR	P11DR	P10DR	PORT
P3DR	P37DR	P36DR	P35DR	P34DR	P33DR	P32DR	P31DR	P30DR	
P7DR	P77DR	P76DR	P75DR	P74DR	P73DR	P72DR	P71DR	P70DR	
PADR	—	—	—	—	PA3DR	PA2DR	PA1DR	PA0DR	

Abbrevia- tion	Bit 7	Bit 6	Bit 5	Bit 4	Bit 3	Bit 2	Bit 1	Bit 0	Module
PBDR	PB7DR	PB6DR	PB5DR	PB4DR	PB3DR	PB2DR	PB1DR	PB0DR	PORT
PCDR	PC7DR	PC6DR	PC5DR	PC4DR	PC3DR	PC2DR	PC1DR	PC0DR	
PDDR	PD7DR	PD6DR	PD5DR	PD4DR	PD3DR	PD2DR	PD1DR	PD0DR	
PFDR	PF7DR	PF6DR	PF5DR	PF4DR	PF3DR	PF2DR	PF1DR	PF0DR	
TCR_0	CCLR2	CCLR1	CCLR0	CKEG1	CKEG0	TPSC2	TPSC1	TPSC0	TPU_0
TMDR_0	—	—	BFB	BFA	MD3	MD2	MD1	MD0	
TIORH_0	IOB3	IOB2	IOB1	IOB0	IOA3	IOA2	IOA1	IOA0	
TIORL_0	IOD3	IOD2	IOD1	IOD0	IOC3	IOC2	IOC1	IOC0	
TIER_0	TTGE	—	—	TCIEV	TGIED	TGIEC	TGIEB	TGIEA	
TSR_0	—	—	—	TCFV	TGFD	TGFC	TGFB	TGFA	
TCNTH_0	Bit 15	Bit 14	Bit 13	Bit 12	Bit 11	Bit 10	Bit 9	Bit 8	
TCNTL_0	Bit 7	Bit 6	Bit 5	Bit 4	Bit 3	Bit 2	Bit 1	Bit 0	
TGRAH_0	Bit 15	Bit 14	Bit 13	Bit 12	Bit 11	Bit 10	Bit 9	Bit 8	
TGRAL_0	Bit 7	Bit 6	Bit 5	Bit 4	Bit 3	Bit 2	Bit 1	Bit 0	
TGRBH_0	Bit 15	Bit 14	Bit 13	Bit 12	Bit 11	Bit 10	Bit 9	Bit 8	
TGRBL_0	Bit 7	Bit 6	Bit 5	Bit 4	Bit 3	Bit 2	Bit 1	Bit 0	
TGRCH_0	Bit 15	Bit 14	Bit 13	Bit 12	Bit 11	Bit 10	Bit 9	Bit 8	
TGRCL_0	Bit 7	Bit 6	Bit 5	Bit 4	Bit 3	Bit 2	Bit 1	Bit 0	
TGRDH_0	Bit 15	Bit 14	Bit 13	Bit 12	Bit 11	Bit 10	Bit 9	Bit 8	
TGRDL_0	Bit 7	Bit 6	Bit 5	Bit 4	Bit 3	Bit 2	Bit 1	Bit 0	
TCR_1	—	CCLR1	CCLR0	CKEG1	CKEG0	TPSC2	TPSC1	TPSC0	TPU_1
TMDR_1	—	—	—	—	MD3	MD2	MD1	MD0	
TIOR_1	IOB3	IOB2	IOB1	IOB0	IOA3	IOA2	IOA1	IOA0	
TIER_1	TTGE	—	TCIEU	TCIEV	—	—	TGIEB	TGIEA	
TSR_1	TCFD	—	TCFU	TCFV	—	—	TGFB	TGFA	
TCNTH_1	Bit 15	Bit 14	Bit 13	Bit 12	Bit 11	Bit 10	Bit 9	Bit 8	
TCNTL_1	Bit 7	Bit 6	Bit 5	Bit 4	Bit 3	Bit 2	Bit 1	Bit 0	
TGRAH_1	Bit 15	Bit 14	Bit 13	Bit 12	Bit 11	Bit 10	Bit 9	Bit 8	
TGRAL_1	Bit 7	Bit 6	Bit 5	Bit 4	Bit 3	Bit 2	Bit 1	Bit 0	
TGRBH_1	Bit 15	Bit 14	Bit 13	Bit 12	Bit 11	Bit 10	Bit 9	Bit 8	
TGRBL_1	Bit 7	Bit 6	Bit 5	Bit 4	Bit 3	Bit 2	Bit 1	Bit 0	

Abbrevia- tion	Bit 7	Bit 6	Bit 5	Bit 4	Bit 3	Bit 2	Bit 1	Bit 0	Module
TCR_2	—	CCLR1	CCLR0	CKEG1	CKEG0	TPSC2	TPSC1	TPSC0	TPU_2
TMDR_2	—	—	—	—	MD3	MD2	MD1	MD0	
TIOR_2	IOB3	IOB2	IOB1	IOB0	IOA3	IOA2	IOA1	IOA0	
TIER_2	TTGE	—	TCIEU	TCIEV	—	—	TGIEB	TGIEA	
TSR_2	TCFD	—	TCFU	TCFV	—	—	TGFB	TGFA	
TCNTH_2	Bit 15	Bit 14	Bit 13	Bit 12	Bit 11	Bit 10	Bit 9	Bit 8	
TCNTL_2	Bit 7	Bit 6	Bit 5	Bit 4	Bit 3	Bit 2	Bit 1	Bit 0	
TGRAH_2	Bit 15	Bit 14	Bit 13	Bit 12	Bit 11	Bit 10	Bit 9	Bit 8	
TGRAL_2	Bit 7	Bit 6	Bit 5	Bit 4	Bit 3	Bit 2	Bit 1	Bit 0	
TGRBH_2	Bit 15	Bit 14	Bit 13	Bit 12	Bit 11	Bit 10	Bit 9	Bit 8	
TGRBL_2	Bit 7	Bit 6	Bit 5	Bit 4	Bit 3	Bit 2	Bit 1	Bit 0	
TCR_0	CMIEB	CMIEA	OVIE	CCLR1	CCLR0	CKS2	CKS1	CKS0	TMR_0, TMR_1
TCR_1	CMIEB	CMIEA	OVIE	CCLR1	CCLR0	CKS2	CKS1	CKS0	
TCSR_0	CMFB	CMFA	OVF	ADTE	OS3	OS2	OS1	OS0	
TCSR_1	CMFB	CMFA	OVF	—	OS3	OS2	OS1	OS0	
TCORA_0	Bit 7	Bit 6	Bit 5	Bit 4	Bit 3	Bit 2	Bit 1	Bit 0	
TCORA_1	Bit 7	Bit 6	Bit 5	Bit 4	Bit 3	Bit 2	Bit 1	Bit 0	
TCORB_0	Bit 7	Bit 6	Bit 5	Bit 4	Bit 3	Bit 2	Bit 1	Bit 0	
TCORB_1	Bit 7	Bit 6	Bit 5	Bit 4	Bit 3	Bit 2	Bit 1	Bit 0	
TCNT_0	Bit 7	Bit 6	Bit 5	Bit 4	Bit 3	Bit 2	Bit 1	Bit 0	
TCNT_1	Bit 7	Bit 6	Bit 5	Bit 4	Bit 3	Bit 2	Bit 1	Bit 0	
TCSR_0	OVF	WT/IT	TME	—	—	CKS2	CKS1	CKS0	WDT_0
TCNT_0	Bit 7	Bit 6	Bit 5	Bit 4	Bit 3	Bit 2	Bit 1	Bit 0	
RSTCSR	WOVF	RSTE	RSTS	—	—	—	—	—	
SMR_0*1	C/A	CHR	PE	O/E	STOP	MP	CKS1	CKS0	SCI_0
(SMR_0*2)	(GM)	(BLK)	(PE)	(O/E)	(BCP1)	(BCP0)	(CKS1)	(CKS0)	
BRR_0	Bit 7	Bit 6	Bit 5	Bit 4	Bit 3	Bit 2	Bit 1	Bit 0	
SCR_0	TIE	RIE	TE	RE	MPIE	TEIE	CKE1	CKE0	
TDR_0	Bit 7	Bit 6	Bit 5	Bit 4	Bit 3	Bit 2	Bit 1	Bit 0	
SSR_0*1	TDRE	RDRF	ORER	FER	PER	TEND	MPB	MPBT	

Abbrevia- tion	Bit 7	Bit 6	Bit 5	Bit 4	Bit 3	Bit 2	Bit 1	Bit 0	Module
(SSR_0*2)	(TDRE)	(RDRF)	(ORER)	(ERS)	(PER)	(TEND)	(MPB)	(MPBT)	SCI_0
RDR_0	Bit 7	Bit 6	Bit 5	Bit 4	Bit 3	Bit 2	Bit 1	Bit 0	
SCMR_0	—	—	—	—	SDIR	SINV	—	SMIF	
SMR_2*1	C/A	CHR	PE	O/E	STOP	MP	CKS1	CKS0	SCI_2
(SMR_2*2)	(GM)	(BLK)	(PE)	(O/E)	(BCP1)	(BCP0)	(CKS1)	(CKS0)	
BRR_2	Bit 7	Bit 6	Bit 5	Bit 4	Bit 3	Bit 2	Bit 1	Bit 0	
SCR_2	TIE	RIE	TE	RE	MPIE	TEIE	CKE1	CKE0	
TDR_2	Bit 7	Bit 6	Bit 5	Bit 4	Bit 3	Bit 2	Bit 1	Bit 0	
SSR_2*1	TDRE	RDRF	ORER	FER	PER	TEND	MPB	MPBT	
(SSR_2*2)	(TDRE)	(RDRF)	(ORER)	(ERS)	(PER)	(TEND)	(MPB)	(MPBT)	
RDR_2	Bit 7	Bit 6	Bit 5	Bit 4	Bit 3	Bit 2	Bit 1	Bit 0	
SCMR_2	—	—	—	—	SDIR	SINV	—	SMIF	
ADDRAH	AD9	AD8	AD7	AD6	AD5	AD4	AD3	AD2	A/D
ADDRAL	AD1	AD0	—	—	—	—	—	—	
ADDRBH	AD9	AD8	AD7	AD6	AD5	AD4	AD3	AD2	
ADDRBL	AD1	AD0	—	—	—	—	—	—	
ADDRCH	AD9	AD8	AD7	AD6	AD5	AD4	AD3	AD2	
ADDRCL	AD1	AD0	—	—	—	—	—	—	
ADDRDH	AD9	AD8	AD7	AD6	AD5	AD4	AD3	AD2	
ADDRDL	AD1	AD0	—	—	—	—	—	—	
ADCSR	ADF	ADIE	ADST	SCAN	CH3	CH2	CH1	CH0	
ADCR	TRGS1	TRGS0	—	—	CKS1	CKS0	—	—	
FLMCR1	FWE	SWE	ESU1	PSU1	EV1	PV1	E1	P1	FLASH (F-ZTAT Version)
FLMCR2	FLER	—	—	—	—	—	—	—	
EBR1	EB7	EB6	EB5	EB4	EB3	EB2	EB1	EB0	
EBR2	—	—	—	—	—	—	EB9	EB8	
PORT1	P17	P16	P15	P14	P13	P12	P11	P10	PORT
PORT3	P37	P36	P35	P34	P33	P32	P31	P30	
PORT4	P47	P46	P45	P44	P43	P42	P41	P40	
PORT7	P77	P76	P75	P74	P73	P72	P71	P70	
PORT9	P97	P96	P95	P94	P93	P92	P91	P90	

Abbrevia- tion	Bit 7	Bit 6	Bit 5	Bit 4	Bit 3	Bit 2	Bit 1	Bit 0	Module
PORTA	—	—	—	—	PA3	PA2	PA1	PA0	PORT
PORTB	PB7	PB6	PB5	PB4	PB3	PB2	PB1	PB0	
PORTC	PC7	PC6	PC5	PC4	PC3	PC2	PC1	PC0	
PORTD	PD7	PD6	PD5	PD4	PD3	PD2	PD1	PD0	
PORTF	PF7	PF6	PF5	PF4	PF3	PF2	PF1	PF0	

Notes: 1. Normal serial communication interface mode.

2. Smart Card interface mode.

Some bit functions of SMR differ in normal serial communication interface mode and Smart Card interface mode.

22.3 Register States in Each Operating Mode

Register Abbreviation	Reset	High Speed	Medium Speed	Sleep	Module Stop	Software Standby	Hardware Standby	Module
MCR	Initialized	—	—	—	Initialized	Initialized	Initialized	HCAN
GSR	Initialized	—	—	—	Initialized	Initialized	Initialized	
BCR	Initialized	—	—	—	Initialized	Initialized	Initialized	
MBCR	Initialized	—	—	—	Initialized	Initialized	Initialized	
TXPR	Initialized	—	—	—	Initialized	Initialized	Initialized	
TXCR	Initialized	—	—	—	Initialized	Initialized	Initialized	
TXACK	Initialized	—	—	—	Initialized	Initialized	Initialized	
ABACK	Initialized	—	—	—	Initialized	Initialized	Initialized	
RXPR	Initialized	—	—	—	Initialized	Initialized	Initialized	
RFPR	Initialized	—	—	—	Initialized	Initialized	Initialized	
IRR	Initialized	—	—	—	Initialized	Initialized	Initialized	
MBIMR	Initialized	—	—	—	Initialized	Initialized	Initialized	
IMR	Initialized	—	—	—	Initialized	Initialized	Initialized	
REC	Initialized	—	—	—	Initialized	Initialized	Initialized	
TEC	Initialized	—	—	—	Initialized	Initialized	Initialized	
UMSR	Initialized	—	—	—	Initialized	Initialized	Initialized	
LAFML	Initialized	—	—	—	Initialized	Initialized	Initialized	
LAFMH	Initialized	—	—	—	Initialized	Initialized	Initialized	
MC0[1]	—	—	—	—	—	—	—	
MC0[2]	—	—	—	—	—	—	—	
MC0[3]	—	—	—	—	—	—	—	
MC0[4]	—	—	—	—	—	—	—	
MC0[5]	—	—	—	—	—	—	—	
MC0[6]	—	—	—	—	—	—	—	
MC0[7]	—	—	—	—	—	—	—	
MC0[8]	—	—	—	—	—	—	—	
MC1[1]	—	—	—	—	—	—	—	
MC1[2]	—	—	—	—	—	—	—	

Register Abbreviation	Reset	High Speed	Medium Speed	Sleep	Module Stop	Software Standby	Hardware Standby	Module
MC1[3]	—	—	—	—	—	—	—	HCAN
MC1[4]	—	—	—	—	—	—	—	
MC1[5]	—	—	—	—	—	—	—	
MC1[6]	—	—	—	—	—	—	—	
MC1[7]	—	—	—	—	—	—	—	
MC1[8]	—	—	—	—	—	—	—	
MC2[1]	—	—	—	—	—	—	—	
MC2[2]	—	—	—	—	—	—	—	
MC2[3]	—	—	—	—	—	—	—	
MC2[4]	—	—	—	—	—	—	—	
MC2[5]	—	—	—	—	—	—	—	
MC2[6]	—	—	—	—	—	—	—	
MC2[7]	—	—	—	—	—	—	—	
MC2[8]	—	—	—	—	—	—	—	
MC3[1]	—	—	—	—	—	—	—	
MC3[2]	—	—	—	—	—	—	—	
MC3[3]	—	—	—	—	—	—	—	
MC3[4]	—	—	—	—	—	—	—	
MC3[5]	—	—	—	—	—	—	—	
MC3[6]	—	—	—	—	—	—	—	
MC3[7]	—	—	—	—	—	—	—	
MC3[8]	—	—	—	—	—	—	—	
MC4[1]	—	—	—	—	—	—	—	
MC4[2]	—	—	—	—	—	—	—	
MC4[3]	—	—	—	—	—	—	—	
MC4[4]	—	—	—	—	—	—	—	
MC4[5]	—	—	—	—	—	—	—	
MC4[6]	—	—	—	—	—	—	—	
MC4[7]	—	—	—	—	—	—	—	
MC4[8]	—	—	—	—	—	—	—	

Register Abbreviation	Reset	High Speed	Medium Speed	Sleep	Module Stop	Software Standby	Hardware Standby	Module
MC5[1]	—	—	—	—	—	—	—	HCAN
MC5[2]	—	—	—	—	—	—	—	
MC5[3]	—	—	—	—	—	—	—	
MC5[4]	—	—	—	—	—	—	—	
MC5[5]	—	—	—	—	—	—	—	
MC5[6]	—	—	—	—	—	—	—	
MC5[7]	—	—	—	—	—	—	—	
MC5[8]	—	—	—	—	—	—	—	
MC6[1]	—	—	—	—	—	—	—	
MC6[2]	—	—	—	—	—	—	—	
MC6[3]	—	—	—	—	—	—	—	
MC6[4]	—	—	—	—	—	—	—	
MC6[5]	—	—	—	—	—	—	—	
MC6[6]	—	—	—	—	—	—	—	
MC6[7]	—	—	—	—	—	—	—	
MC6[8]	—	—	—	—	—	—	—	
MC7[1]	—	—	—	—	—	—	—	
MC7[2]	—	—	—	—	—	—	—	
MC7[3]	—	—	—	—	—	—	—	
MC7[4]	—	—	—	—	—	—	—	
MC7[5]	—	—	—	—	—	—	—	
MC7[6]	—	—	—	—	—	—	—	
MC7[7]	—	—	—	—	—	—	—	
MC7[8]	—	—	—	—	—	—	—	
MC8[1]	—	—	—	—	—	—	—	
MC8[2]	—	—	—	—	—	—	—	
MC8[3]	—	—	—	—	—	—	—	
MC8[4]	—	—	—	—	—	—	—	
MC8[5]	—	—	—	—	—	—	—	
MC8[6]	—	—	—	—	—	—	—	

Register Abbreviation	Reset	High Speed	Medium Speed	Sleep	Module Stop	Software Standby	Hardware Standby	Module
MC8[7]	—	—	—	—	—	—	—	HCAN
MC8[8]	—	—	—	—	—	—	—	
MC9[1]	—	—	—	—	—	—	—	
MC9[2]	—	—	—	—	—	—	—	
MC9[3]	—	—	—	—	—	—	—	
MC9[4]	—	—	—	—	—	—	—	
MC9[5]	—	—	—	—	—	—	—	
MC9[6]	—	—	—	—	—	—	—	
MC9[7]	—	—	—	—	—	—	—	
MC9[8]	—	—	—	—	—	—	—	
MC10[1]	—	—	—	—	—	—	—	
MC10[2]	—	—	—	—	—	—	—	
MC10[3]	—	—	—	—	—	—	—	
MC10[4]	—	—	—	—	—	—	—	
MC10[5]	—	—	—	—	—	—	—	
MC10[6]	—	—	—	—	—	—	—	
MC10[7]	—	—	—	—	—	—	—	
MC10[8]	—	—	—	—	—	—	—	
MC11[1]	—	—	—	—	—	—	—	
MC11[2]	—	—	—	—	—	—	—	
MC11[3]	—	—	—	—	—	—	—	
MC11[4]	—	—	—	—	—	—	—	
MC11[5]	—	—	—	—	—	—	—	
MC11[6]	—	—	—	—	—	—	—	
MC11[7]	—	—	—	—	—	—	—	
MC11[8]	—	—	—	—	—	—	—	
MC12[1]	—	—	—	—	—	—	—	
MC12[2]	—	—	—	—	—	—	—	
MC12[3]	—	—	—	—	—	—	—	
MC12[4]	—	—	—	—	—	—	—	

Register Abbreviation	Reset	High Speed	Medium Speed	Sleep	Module Stop	Software Standby	Hardware Standby	Module
MC12[5]	—	—	—	—	—	—	—	HCAN
MC12[6]	—	—	—	—	—	—	—	
MC12[7]	—	—	—	—	—	—	—	
MC12[8]	—	—	—	—	—	—	—	
MC13[1]	—	—	—	—	—	—	—	
MC13[2]	—	—	—	—	—	—	—	
MC13[3]	—	—	—	—	—	—	—	
MC13[4]	—	—	—	—	—	—	—	
MC13[5]	—	—	—	—	—	—	—	
MC13[6]	—	—	—	—	—	—	—	
MC13[7]	—	—	—	—	—	—	—	
MC13[8]	—	—	—	—	—	—	—	
MC14[1]	—	—	—	—	—	—	—	
MC14[2]	—	—	—	—	—	—	—	
MC14[3]	—	—	—	—	—	—	—	
MC14[4]	—	—	—	—	—	—	—	
MC14[5]	—	—	—	—	—	—	—	
MC14[6]	—	—	—	—	—	—	—	
MC14[7]	—	—	—	—	—	—	—	
MC14[8]	—	—	—	—	—	—	—	
MC15[1]	—	—	—	—	—	—	—	
MC15[2]	—	—	—	—	—	—	—	
MC15[3]	—	—	—	—	—	—	—	
MC15[4]	—	—	—	—	—	—	—	
MC15[5]	—	—	—	—	—	—	—	
MC15[6]	—	—	—	—	—	—	—	
MC15[7]	—	—	—	—	—	—	—	
MC15[8]	—	—	—	—	—	—	—	
MD0[1]	—	—	—	—	—	—	—	
MD0[2]	—	—	—	—	—	—	—	

Register Abbreviation	Reset	High Speed	Medium Speed	Sleep	Module Stop	Software Standby	Hardware Standby	Module
MD0[3]	—	—	—	—	—	—	—	HCAN
MD0[4]	—	—	—	—	—	—	—	
MD0[5]	—	—	—	—	—	—	—	
MD0[6]	—	—	—	—	—	—	—	
MD0[7]	—	—	—	—	—	—	—	
MD0[8]	—	—	—	—	—	—	—	
MD1[1]	—	—	—	—	—	—	—	
MD1[2]	—	—	—	—	—	—	—	
MD1[3]	—	—	—	—	—	—	—	
MD1[4]	—	—	—	—	—	—	—	
MD1[5]	—	—	—	—	—	—	—	
MD1[6]	—	—	—	—	—	—	—	
MD1[7]	—	—	—	—	—	—	—	
MD1[8]	—	—	—	—	—	—	—	
MD2[1]	—	—	—	—	—	—	—	
MD2[2]	—	—	—	—	—	—	—	
MD2[3]	—	—	—	—	—	—	—	
MD2[4]	—	—	—	—	—	—	—	
MD2[5]	—	—	—	—	—	—	—	
MD2[6]	—	—	—	—	—	—	—	
MD2[7]	—	—	—	—	—	—	—	
MD2[8]	—	—	—	—	—	—	—	
MD3[1]	—	—	—	—	—	—	—	
MD3[2]	—	—	—	—	—	—	—	
MD3[3]	—	—	—	—	—	—	—	
MD3[4]	—	—	—	—	—	—	—	
MD3[5]	—	—	—	—	—	—	—	
MD3[6]	—	—	—	—	—	—	—	
MD3[7]	—	—	—	—	—	—	—	
MD3[8]	—	—	—	—	—	—	—	

Register Abbreviation	Reset	High Speed	Medium Speed	Sleep	Module Stop	Software Standby	Hardware Standby	Module
MD4[1]	—	—	—	—	—	—	—	HCAN
MD4[2]	—	—	—	—	—	—	—	
MD4[3]	—	—	—	—	—	—	—	
MD4[4]	—	—	—	—	—	—	—	
MD4[5]	—	—	—	—	—	—	—	
MD4[6]	—	—	—	—	—	—	—	
MD4[7]	—	—	—	—	—	—	—	
MD4[8]	—	—	—	—	—	—	—	
MD5[1]	—	—	—	—	—	—	—	
MD5[2]	—	—	—	—	—	—	—	
MD5[3]	—	—	—	—	—	—	—	
MD5[4]	—	—	—	—	—	—	—	
MD5[5]	—	—	—	—	—	—	—	
MD5[6]	—	—	—	—	—	—	—	
MD5[7]	—	—	—	—	—	—	—	
MD5[8]	—	—	—	—	—	—	—	
MD6[1]	—	—	—	—	—	—	—	
MD6[2]	—	—	—	—	—	—	—	
MD6[3]	—	—	—	—	—	—	—	
MD6[4]	—	—	—	—	—	—	—	
MD6[5]	—	—	—	—	—	—	—	
MD6[6]	—	—	—	—	—	—	—	
MD6[7]	—	—	—	—	—	—	—	
MD6[8]	—	—	—	—	—	—	—	
MD7[1]	—	—	—	—	—	—	—	
MD7[2]	—	—	—	—	—	—	—	
MD7[3]	—	—	—	—	—	—	—	
MD7[4]	—	—	—	—	—	—	—	
MD7[5]	—	—	—	—	—	—	—	
MD7[6]	—	—	—	—	—	—	—	

Register Abbreviation	Reset	High Speed	Medium Speed	Sleep	Module Stop	Software Standby	Hardware Standby	Module
MD7[7]	—	—	—	—	—	—	—	HCAN
MD7[8]	—	—	—	—	—	—	—	
MD8[1]	—	—	—	—	—	—	—	
MD8[2]	—	—	—	—	—	—	—	
MD8[3]	—	—	—	—	—	—	—	
MD8[4]	—	—	—	—	—	—	—	
MD8[5]	—	—	—	—	—	—	—	
MD8[6]	—	—	—	—	—	—	—	
MD8[7]	—	—	—	—	—	—	—	
MD8[8]	—	—	—	—	—	—	—	
MD9[1]	—	—	—	—	—	—	—	
MD9[2]	—	—	—	—	—	—	—	
MD9[3]	—	—	—	—	—	—	—	
MD9[4]	—	—	—	—	—	—	—	
MD9[5]	—	—	—	—	—	—	—	
MD9[6]	—	—	—	—	—	—	—	
MD9[7]	—	—	—	—	—	—	—	
MD9[8]	—	—	—	—	—	—	—	
MD10[1]	—	—	—	—	—	—	—	
MD10[2]	—	—	—	—	—	—	—	
MD10[3]	—	—	—	—	—	—	—	
MD10[4]	—	—	—	—	—	—	—	
MD10[5]	—	—	—	—	—	—	—	
MD10[6]	—	—	—	—	—	—	—	
MD10[7]	—	—	—	—	—	—	—	
MD10[8]	—	—	—	—	—	—	—	
MD11[1]	—	—	—	—	—	—	—	
MD11[2]	—	—	—	—	—	—	—	
MD11[3]	—	—	—	—	—	—	—	
MD11[4]	—	—	—	—	—	—	—	

Register Abbreviation	Reset	High Speed	Medium Speed	Sleep	Module Stop	Software Standby	Hardware Standby	Module
MD11[5]	—	—	—	—	—	—	—	HCAN
MD11[6]	—	—	—	—	—	—	—	
MD11[7]	—	—	—	—	—	—	—	
MD11[8]	—	—	—	—	—	—	—	
MD12[1]	—	—	—	—	—	—	—	
MD12[2]	—	—	—	—	—	—	—	
MD12[3]	—	—	—	—	—	—	—	
MD12[4]	—	—	—	—	—	—	—	
MD12[5]	—	—	—	—	—	—	—	
MD12[6]	—	—	—	—	—	—	—	
MD12[7]	—	—	—	—	—	—	—	
MD12[8]	—	—	—	—	—	—	—	
MD13[1]	—	—	—	—	—	—	—	
MD13[2]	—	—	—	—	—	—	—	
MD13[3]	—	—	—	—	—	—	—	
MD13[4]	—	—	—	—	—	—	—	
MD13[5]	—	—	—	—	—	—	—	
MD13[6]	—	—	—	—	—	—	—	
MD13[7]	—	—	—	—	—	—	—	
MD13[8]	—	—	—	—	—	—	—	
MD14[1]	—	—	—	—	—	—	—	
MD14[2]	—	—	—	—	—	—	—	
MD14[3]	—	—	—	—	—	—	—	
MD14[4]	—	—	—	—	—	—	—	
MD14[5]	—	—	—	—	—	—	—	
MD14[6]	—	—	—	—	—	—	—	
MD14[7]	—	—	—	—	—	—	—	
MD14[8]	—	—	—	—	—	—	—	
MD15[1]	—	—	—	—	—	—	—	
MD15[2]	—	—	—	—	—	—	—	

Register Abbreviation	Reset	High Speed	Medium Speed	Sleep	Module Stop	Software Standby	Hardware Standby	Module
MD15[3]	—	—	—	—	—	—	—	HCAN
MD15[4]	—	—	—	—	—	—	—	
MD15[5]	—	—	—	—	—	—	—	
MD15[6]	—	—	—	—	—	—	—	
MD15[7]	—	—	—	—	—	—	—	
MD15[8]	—	—	—	—	—	—	—	
HCANMON	Initialized	—	—	—	—	—	Initialized	
SSCRH_0	Initialized	—	—	—	Initialized	Initialized	Initialized	SSU_0
SSCRL_0	Initialized	—	—	—	Initialized	Initialized	Initialized	
SSMR_0	Initialized	—	—	—	Initialized	Initialized	Initialized	
SSER_0	Initialized	—	—	—	Initialized	Initialized	Initialized	
SSSR_0	Initialized	—	—	—	Initialized	Initialized	Initialized	
SSTDR0_0	Initialized	—	—	—	Initialized	Initialized	Initialized	
SSTDR1_0	Initialized	—	—	—	Initialized	Initialized	Initialized	
SSTDR2_0	Initialized	—	—	—	Initialized	Initialized	Initialized	
SSTDR3_0	Initialized	—	—	—	Initialized	Initialized	Initialized	
SSRDR0_0	Initialized	—	—	—	Initialized	Initialized	Initialized	
SSRDR1_0	Initialized	—	—	—	Initialized	Initialized	Initialized	
SSRDR2_0	Initialized	—	—	—	Initialized	Initialized	Initialized	
SSRDR3_0	Initialized	—	—	—	Initialized	Initialized	Initialized	
SSCRH_1	Initialized	—	—	—	Initialized	Initialized	Initialized	SSU_1
SSCRL_1	Initialized	—	—	—	Initialized	Initialized	Initialized	
SSMR_1	Initialized	—	—	—	Initialized	Initialized	Initialized	
SSER_1	Initialized	—	—	—	Initialized	Initialized	Initialized	
SSSR_1	Initialized	—	—	—	Initialized	Initialized	Initialized	
SSTDR0_1	Initialized	—	—	—	Initialized	Initialized	Initialized	
SSTDR1_1	Initialized	—	—	—	Initialized	Initialized	Initialized	
SSTDR2_1	Initialized	—	—	—	Initialized	Initialized	Initialized	
SSTDR3_1	Initialized	—	—	—	Initialized	Initialized	Initialized	
SSRDR0_1	Initialized	—	—	—	Initialized	Initialized	Initialized	

Register Abbreviation	Reset	High Speed	Medium Speed	Sleep	Module Stop	Software Standby	Hardware Standby	Module	
SSRDR1_1	Initialized	—	—	—	Initialized	Initialized	Initialized	SSU_1	
SSRDR2_1	Initialized	—	—	—	Initialized	Initialized	Initialized		
SSRDR3_1	Initialized	—	—	—	Initialized	Initialized	Initialized		
PDRTIDR	Initialized	—	—	—	—	—	Initialized	PORT	
TCR_2	Initialized	—	—	—	—	—	Initialized	TMR_2, TMR_3	
TCR_3	Initialized	—	—	—	—	—	Initialized		
TCSR_2	Initialized	—	—	—	—	—	Initialized		
TCSR_3	Initialized	—	—	—	—	—	Initialized		
TCORA_2	Initialized	—	—	—	—	—	Initialized		
TCORA_3	Initialized	—	—	—	—	—	Initialized		
TCORB_2	Initialized	—	—	—	—	—	Initialized		
TCORB_3	Initialized	—	—	—	—	—	Initialized		
TCNT_2	Initialized	—	—	—	—	—	Initialized		
TCNT_3	Initialized	—	—	—	—	—	Initialized		
SBYCR	Initialized	—	—	—	—	—	—	SYSTEM	
SYSCR	Initialized	—	—	—	—	—	—		
SCKCR	Initialized	—	—	—	—	—	—		
MDCR	Initialized	—	—	—	—	—	—		
MSTPCRA	Initialized	—	—	—	—	—	—		
MSTPCRB	Initialized	—	—	—	—	—	—		
MSTPCRC	Initialized	—	—	—	—	—	—		
LPWRCR	Initialized	—	—	—	—	—	—		
BARA	Initialized	—	—	—	—	—	Initialized		PBC
BARB	Initialized	—	—	—	—	—	Initialized		
BCRA	Initialized	—	—	—	—	—	Initialized		
BCRB	Initialized	—	—	—	—	—	Initialized		
ISCRH	Initialized	—	—	—	—	—	Initialized	INT	
ISCR_L	Initialized	—	—	—	—	—	Initialized		
IER	Initialized	—	—	—	—	—	Initialized		
ISR	Initialized	—	—	—	—	—	Initialized		

Register Abbreviation	Reset	High Speed	Medium Speed	Sleep	Module Stop	Software Standby	Hardware Standby	Module
DTCERA	Initialized	—	—	—	—	—	Initialized	DTC
DTCERB	Initialized	—	—	—	—	—	Initialized	
DTCERC	Initialized	—	—	—	—	—	Initialized	
DTCERD	Initialized	—	—	—	—	—	Initialized	
DTCERE	Initialized	—	—	—	—	—	Initialized	
DTCERF	Initialized	—	—	—	—	—	Initialized	
DTCERG	Initialized	—	—	—	—	—	Initialized	
DTVECR	Initialized	—	—	—	—	—	Initialized	
PCR	Initialized	—	—	—	—	—	Initialized	PPG
PMR	Initialized	—	—	—	—	—	Initialized	
NDERH	Initialized	—	—	—	—	—	Initialized	
NDERL	Initialized	—	—	—	—	—	Initialized	
PODRH	Initialized	—	—	—	—	—	Initialized	
PODRL	Initialized	—	—	—	—	—	Initialized	
NDRH	Initialized	—	—	—	—	—	Initialized	
NDRL	Initialized	—	—	—	—	—	Initialized	
NDRH	Initialized	—	—	—	—	—	Initialized	
NDRL	Initialized	—	—	—	—	—	Initialized	
P1DDR	Initialized	—	—	—	—	—	—	PORT
P3DDR	Initialized	—	—	—	—	—	—	
P7DDR	Initialized	—	—	—	—	—	—	
PADDR	Initialized	—	—	—	—	—	—	
PBDDR	Initialized	—	—	—	—	—	—	
PCDDR	Initialized	—	—	—	—	—	—	
PDDDR	Initialized	—	—	—	—	—	—	
PFDDR	Initialized	—	—	—	—	—	—	
PAPCR	Initialized	—	—	—	—	—	—	
PBPCR	Initialized	—	—	—	—	—	—	
PCPCR	Initialized	—	—	—	—	—	—	
PDPCR	Initialized	—	—	—	—	—	—	

Register Abbreviation	Reset	High Speed	Medium Speed	Sleep	Module Stop	Software Standby	Hardware Standby	Module
P3ODR	Initialized	—	—	—	—	—	—	PORT
PAODR	Initialized	—	—	—	—	—	—	
PBODR	Initialized	—	—	—	—	—	—	
PCODR	Initialized	—	—	—	—	—	—	
TCR_3	Initialized	—	—	—	—	—	Initialized	TPU_3
TMDR_3	Initialized	—	—	—	—	—	Initialized	
TIORH_3	Initialized	—	—	—	—	—	Initialized	
TIORL_3	Initialized	—	—	—	—	—	Initialized	
TIER_3	Initialized	—	—	—	—	—	Initialized	
TSR_3	Initialized	—	—	—	—	—	Initialized	
TCNTH_3	Initialized	—	—	—	—	—	Initialized	
TCNTL_3	Initialized	—	—	—	—	—	Initialized	
TGRAH_3	Initialized	—	—	—	—	—	Initialized	
TGRAL_3	Initialized	—	—	—	—	—	Initialized	
TGRBH_3	Initialized	—	—	—	—	—	Initialized	
TGRBL_3	Initialized	—	—	—	—	—	Initialized	
TGRCH_3	Initialized	—	—	—	—	—	Initialized	
TGRCL_3	Initialized	—	—	—	—	—	Initialized	
TGRDH_3	Initialized	—	—	—	—	—	Initialized	
TGRDL_3	Initialized	—	—	—	—	—	Initialized	
TCR_4	Initialized	—	—	—	—	—	Initialized	TPU_4
TMDR_4	Initialized	—	—	—	—	—	Initialized	
TIOR_4	Initialized	—	—	—	—	—	Initialized	
TIER_4	Initialized	—	—	—	—	—	Initialized	
TSR_4	Initialized	—	—	—	—	—	Initialized	
TCNTH_4	Initialized	—	—	—	—	—	Initialized	
TCNTL_4	Initialized	—	—	—	—	—	Initialized	
TGRAH_4	Initialized	—	—	—	—	—	Initialized	
TGRAL_4	Initialized	—	—	—	—	—	Initialized	
TGRBH_3	Initialized	—	—	—	—	—	Initialized	
TGRBL_4	Initialized	—	—	—	—	—	Initialized	

Register Abbreviation	Reset	High Speed	Medium Speed	Sleep	Module Stop	Software Standby	Hardware Standby	Module
TCR_5	Initialized	—	—	—	—	—	Initialized	TPU_5
TMDR_5	Initialized	—	—	—	—	—	Initialized	
TIOR_5	Initialized	—	—	—	—	—	Initialized	
TIER_5	Initialized	—	—	—	—	—	Initialized	
TSR_5	Initialized	—	—	—	—	—	Initialized	
TCNTH_5	Initialized	—	—	—	—	—	Initialized	
TCNTL_5	Initialized	—	—	—	—	—	Initialized	
TGRAH_5	Initialized	—	—	—	—	—	Initialized	
TGRAL_5	Initialized	—	—	—	—	—	Initialized	
TGRBH_5	Initialized	—	—	—	—	—	Initialized	
TGRBL_5	Initialized	—	—	—	—	—	Initialized	
TSTR	Initialized	—	—	—	—	—	Initialized	TPU common
TSYR	Initialized	—	—	—	—	—	Initialized	
IPRA	Initialized	—	—	—	—	—	Initialized	INT
IPRB	Initialized	—	—	—	—	—	Initialized	
IPRC	Initialized	—	—	—	—	—	Initialized	
IPRD	Initialized	—	—	—	—	—	Initialized	
IPRE	Initialized	—	—	—	—	—	Initialized	
IPRF	Initialized	—	—	—	—	—	Initialized	
IPRG	Initialized	—	—	—	—	—	Initialized	
IPRH	Initialized	—	—	—	—	—	Initialized	
IPRJ	Initialized	—	—	—	—	—	Initialized	
IPRK	Initialized	—	—	—	—	—	Initialized	
IPRM	Initialized	—	—	—	—	—	Initialized	
RAMER	Initialized	—	—	—	—	—	Initialized	ROM
P1DR	Initialized	—	—	—	—	—	—	PORT
P3DR	Initialized	—	—	—	—	—	—	
P7DR	Initialized	—	—	—	—	—	—	
PADR	Initialized	—	—	—	—	—	—	
PBDR	Initialized	—	—	—	—	—	—	

Register Abbreviation	Reset	High Speed	Medium Speed	Sleep	Module Stop	Software Standby	Hardware Standby	Module
PCDR	Initialized	—	—	—	—	—	—	PORT
PDDR	Initialized	—	—	—	—	—	—	
PFDR	Initialized	—	—	—	—	—	—	
TCR_0	Initialized	—	—	—	—	—	Initialized	TPU_0
TMDR_0	Initialized	—	—	—	—	—	Initialized	
TIORH_0	Initialized	—	—	—	—	—	Initialized	
TIORL_0	Initialized	—	—	—	—	—	Initialized	
TIER_0	Initialized	—	—	—	—	—	Initialized	
TSR_0	Initialized	—	—	—	—	—	Initialized	
TCNTH_0	Initialized	—	—	—	—	—	Initialized	
TCNTL_0	Initialized	—	—	—	—	—	Initialized	
TGRAH_0	Initialized	—	—	—	—	—	Initialized	
TGRAL_0	Initialized	—	—	—	—	—	Initialized	
TGRBH_0	Initialized	—	—	—	—	—	Initialized	
TGRBL_0	Initialized	—	—	—	—	—	Initialized	
TGRCH_0	Initialized	—	—	—	—	—	Initialized	
TGRCL_0	Initialized	—	—	—	—	—	Initialized	
TGRDH_0	Initialized	—	—	—	—	—	Initialized	
TGRDL_0	Initialized	—	—	—	—	—	Initialized	
TCR_1	Initialized	—	—	—	—	—	Initialized	TPU_1
TMDR_1	Initialized	—	—	—	—	—	Initialized	
TIOR_1	Initialized	—	—	—	—	—	Initialized	
TIER_1	Initialized	—	—	—	—	—	Initialized	
TSR_1	Initialized	—	—	—	—	—	Initialized	
TCNTH_1	Initialized	—	—	—	—	—	Initialized	
TCNTL_1	Initialized	—	—	—	—	—	Initialized	
TGRAH_1	Initialized	—	—	—	—	—	Initialized	
TGRAL_1	Initialized	—	—	—	—	—	Initialized	
TGRBH_1	Initialized	—	—	—	—	—	Initialized	
TGRBL_1	Initialized	—	—	—	—	—	Initialized	

Register Abbreviation	Reset	High Speed	Medium Speed	Sleep	Module Stop	Software Standby	Hardware Standby	Module
TCR_2	Initialized	—	—	—	—	—	Initialized	TPU_2
TMDR_2	Initialized	—	—	—	—	—	Initialized	
TIOR_2	Initialized	—	—	—	—	—	Initialized	
TIER_2	Initialized	—	—	—	—	—	Initialized	
TSR_2	Initialized	—	—	—	—	—	Initialized	
TCNTH_2	Initialized	—	—	—	—	—	Initialized	
TCNTL_2	Initialized	—	—	—	—	—	Initialized	
TGRAH_2	Initialized	—	—	—	—	—	Initialized	
TGRAL_2	Initialized	—	—	—	—	—	Initialized	
TGRBH_2	Initialized	—	—	—	—	—	Initialized	
TGRBL_2	Initialized	—	—	—	—	—	Initialized	
TCR_0	Initialized	—	—	—	—	—	Initialized	TMR_0,
TCR_1	Initialized	—	—	—	—	—	Initialized	TMR_1
TCSR_0	Initialized	—	—	—	—	—	Initialized	
TCSR_1	Initialized	—	—	—	—	—	Initialized	
TCORA_0	Initialized	—	—	—	—	—	Initialized	
TCORA_1	Initialized	—	—	—	—	—	Initialized	
TCORB_0	Initialized	—	—	—	—	—	Initialized	
TCORB_1	Initialized	—	—	—	—	—	Initialized	
TCNT_0	Initialized	—	—	—	—	—	Initialized	
TCNT_1	Initialized	—	—	—	—	—	Initialized	
TCSR_0	Initialized	—	—	—	—	—	Initialized	WDT_0
TCNT_0	Initialized	—	—	—	—	—	Initialized	
RSTCSR	Initialized	—	—	—	—	—	Initialized	
SMR_0	Initialized	—	—	—	—	—	Initialized	SCI_0
BRR_0	Initialized	—	—	—	—	—	Initialized	
SCR_0	Initialized	—	—	—	—	—	Initialized	
TDR_0	Initialized	—	—	—	—	Initialized	Initialized	
SSR_0	Initialized	—	—	—	—	Initialized	Initialized	
RDR_0	Initialized	—	—	—	—	Initialized	Initialized	
SCMR_0	Initialized	—	—	—	—	—	Initialized	

Register Abbreviation	Reset	High Speed	Medium Speed	Sleep	Module Stop	Software Standby	Hardware Standby	Module
SMR_2	Initialized	—	—	—	—	—	Initialized	SCI_2
BRR_2	Initialized	—	—	—	—	—	Initialized	
SCR_2	Initialized	—	—	—	—	—	Initialized	
TDR_2	Initialized	—	—	—	Initialized	Initialized	Initialized	
SSR_2	Initialized	—	—	—	Initialized	Initialized	Initialized	
RDR_2	Initialized	—	—	—	Initialized	Initialized	Initialized	
SCMR_2	Initialized	—	—	—	—	—	Initialized	
ADDRAH	Initialized	—	—	—	Initialized	Initialized	Initialized	A/D
ADDRAL	Initialized	—	—	—	Initialized	Initialized	Initialized	
ADDRBH	Initialized	—	—	—	Initialized	Initialized	Initialized	
ADDRBL	Initialized	—	—	—	Initialized	Initialized	Initialized	
ADDRCH	Initialized	—	—	—	Initialized	Initialized	Initialized	
ADDRCL	Initialized	—	—	—	Initialized	Initialized	Initialized	
ADDRDH	Initialized	—	—	—	Initialized	Initialized	Initialized	
ADDRDL	Initialized	—	—	—	Initialized	Initialized	Initialized	
ADCSR	Initialized	—	—	—	Initialized	Initialized	Initialized	
ADCR	Initialized	—	—	—	Initialized	Initialized	Initialized	
FLMCR1	Initialized	—	—	—	—	—	Initialized	ROM
FLMCR2	Initialized	—	—	—	—	—	Initialized	
EBR1	Initialized	—	—	—	—	—	Initialized	
EBR2	Initialized	—	—	—	—	—	Initialized	
PORT1	Initialized	—	—	—	—	—	—	PORT
PORT3	Initialized	—	—	—	—	—	—	
PORT4	Initialized	—	—	—	—	—	—	
PORT7	Initialized	—	—	—	—	—	—	
PORT9	Initialized	—	—	—	—	—	—	
PORTA	Initialized	—	—	—	—	—	—	
PORTB	Initialized	—	—	—	—	—	—	
PORTC	Initialized	—	—	—	—	—	—	
PORTD	Initialized	—	—	—	—	—	—	
PORTF	Initialized	—	—	—	—	—	—	

Note: — is not initialized.

Section 23 Electrical Characteristics

23.1 Absolute Maximum Ratings

Table 23.1 lists the absolute maximum ratings.

Table 23.1 Absolute Maximum Ratings

Item	Symbol	Value	Unit
Power supply voltage	V_{CC}	-0.3 to +7.0	V
Input voltage (XTAL, EXTAL)	V_{in}	-0.3 to $V_{CC} + 0.3$	V
Input voltage (ports 4 and 9)	V_{in}	-0.3 to $AV_{CC} + 0.3$	V
Input voltage (except XTAL, EXTAL, ports 4 and 9)	V_{in}	-0.3 to $V_{CC} + 0.3$	V
Analog power supply voltage	AV_{CC}	-0.3 to +7.0	V
Analog input voltage	V_{AN}	-0.3 to $AV_{CC} + 0.3$	V
Operating temperature	T_{opr}	Regular specifications: -20 to +75	°C
		Wide-range specifications: -40 to +85	°C
Storage temperature	T_{stg}	-55 to +125	°C

Caution: Permanent damage to the chip may result if absolute maximum rating are exceeded.

23.2 DC Characteristics

Table 23.2 lists the DC characteristics. Table 23.3 lists the permissible output currents.

Table 23.2 DC Characteristics

Conditions: $V_{CC} = 4.5\text{ V to }5.5\text{ V}$, $AV_{CC} = 4.5\text{ V to }5.5\text{ V}$, $V_{SS} = AV_{SS} = 0\text{ V}$,
 $T_a = -20^\circ\text{C to }+75^\circ\text{C}$ (regular specifications), $T_a = -40^\circ\text{C to }+85^\circ\text{C}$ (wide-range specifications)*¹

Item	Symbol	Min	Typ	Max	Unit	Test Conditions	
Schmitt trigger input voltage	$\overline{\text{IRQ5}}$ to $\overline{\text{IRQ0}}$	V_T^-	$V_{CC} \times 0.2$	—	—	V	
		V_T^+	—	—	$V_{CC} \times 0.7$	V	
		$V_T^+ - V_T^-$	$V_{CC} \times 0.05$	—	—	V	
Input high voltage	$\overline{\text{RES}}$, $\overline{\text{STBY}}$, NMI, MD2 to MD0, FWE	V_{IH}	$V_{CC} \times 0.9$	—	$V_{CC} + 0.3$	V	
	EXTAL		$V_{CC} \times 0.7$	—	$V_{CC} + 0.3$	V	
	Ports 7, 3, 1, A to D, F, HRxD		$V_{CC} \times 0.7$	—	$V_{CC} + 0.3$	V	
	Ports 9 and 4		$AV_{CC} \times 0.7$	—	$AV_{CC} + 0.3$	V	
Input low voltage	$\overline{\text{RES}}$, $\overline{\text{STBY}}$, NMI, MD2 to MD0, FWE	V_{IL}	-0.3	—	$V_{CC} \times 0.1$	V	
	EXTAL		-0.3	—	$V_{CC} \times 0.2$	V	
	Ports 7, 3, 1, A to D, F, HRxD		-0.3	—	$V_{CC} \times 0.2$	V	
	Ports 9, 4		-0.3	—	$AV_{CC} \times 0.2$	V	
Output high voltage	All output pins	V_{OH}	$V_{CC} - 0.5$	—	—	V	$I_{OH} = -200\ \mu\text{A}$
			$V_{CC} - 1.0$	—	—	V	$I_{OH} = -1\ \text{mA}$
Output low voltage	All output pins	V_{OL}	—	—	0.4	V	$I_{OL} = 1.6\ \text{mA}$

Item	Symbol	Min	Typ	Max	Unit	Test Conditions
Input leakage current	\overline{RES}	$ I_{in} $	—	—	1.0	μA $V_{in} = 0.5$ to $V_{CC} - 0.5$ V
	\overline{STBY} , NMI, MD2 to MD0, FWE, HRxD		—	—	1.0	μA
	Ports 9, 4		—	—	1.0	μA $V_{in} = 0.5$ to $AV_{CC} - 0.5$ V
Input pull-up MOS current	Ports A to D	$-I_P$	30	—	300	μA $V_{in} = 0$ V
Input capacitance	\overline{RES}	C_{in}	—	—	30	pF $V_{in} = 0$ V
	NMI		—	—	30	pF $f = 1$ MHz
	All input pins except \overline{RES} and NMI		—	—	15	pF $T_a = 25^\circ C$
Current consumption*2	Normal operation	I_{CC}^{*3}	—	80	90	mA $f = 24$ MHz $V_{CC} = 5.0$ V $V_{CC} = 5.5$ V
	Sleep mode		—	60	70	mA $f = 24$ MHz $V_{CC} = 5.0$ V $V_{CC} = 5.5$ V
	All modules stopped		—	55	—	mA $f = 24$ MHz, $V_{CC} = 5.0$ V (reference values)
	Medium-speed mode ($\phi/32$)		—	65	—	mA $f = 24$ MHz, $V_{CC} = 5.0$ V (reference values)
	Standby mode		—	2.0	5.0	μA $T_a \leq 50^\circ C$ μA $50^\circ C < T_a$
Analog power supply current	During A/D conversion	AI_{CC}	—	1.0	2.0	mA $AV_{CC} = 5.0$ V
	Idle		—	—	5.0	μA
Reference power supply current	During A/D conversion	AI_{CC}	—	1.0	2.0	mA $V_{ref} = 5.0$ V
	Idle		—	—	5.0	μA
RAM standby voltage	V_{RAM}	2.0	—	—	V	

Notes: 1. If the A/D converter is not used, do not leave the AV_{CC} , V_{ref} , and AV_{SS} pins open. Apply a voltage between 4.5 V and 5.5 V to the AV_{CC} pin by connecting them to V_{CC} , for instance.

2. Current consumption values are for $V_{IH} = V_{CC}$ (EXTAL), AV_{CC} (ports 4 and 9), or V_{CC} (other), and $V_{IL} = 0$ V, with all output pins unloaded and the on-chip pull-up MOS transistors in the off state.
3. I_{CC} depends on V_{CC} and f as follows:
 $I_{CC} (\text{max}) = 27 + 0.435 \times V_{CC} \times f$ (normal operation)
 $I_{CC} (\text{max}) = 27 + 0.3 \times V_{CC} \times f$ (sleep mode)

Table 23.3 Permissible Output Currents

Conditions: $V_{CC} = 4.5$ V to 5.5 V, $AV_{CC} = 4.5$ V to 5.5 V, $V_{SS} = AV_{SS} = 0$ V,
 $T_a = -20^\circ\text{C}$ to $+75^\circ\text{C}$ (regular specifications), $T_a = -40^\circ\text{C}$ to $+85^\circ\text{C}$ (wide-range specifications)*

Item		Symbol	Min	Typ	Max	Unit
Permissible output low current (per pin)	All output pins	$V_{CC} = 4.5$ to 5.5 V	I_{OL}	—	—	10 mA
Permissible output low current (total)	Total of all output pins	$V_{CC} = 4.5$ to 5.5 V	ΣI_{OL}	—	—	100 mA
Permissible output high current (per pin)	All output pins	$V_{CC} = 4.5$ to 5.5 V	$-I_{OH}$	—	—	2.0 mA
Permissible output high current (total)	Total of all output pins	$V_{CC} = 4.5$ to 5.5 V	$\Sigma -I_{OH}$	—	—	30 mA

Note: * To protect chip reliability, do not exceed the output current values in table 23.3.

23.3 AC Characteristics

Figure 23.1 shows the test conditions for the AC characteristics.

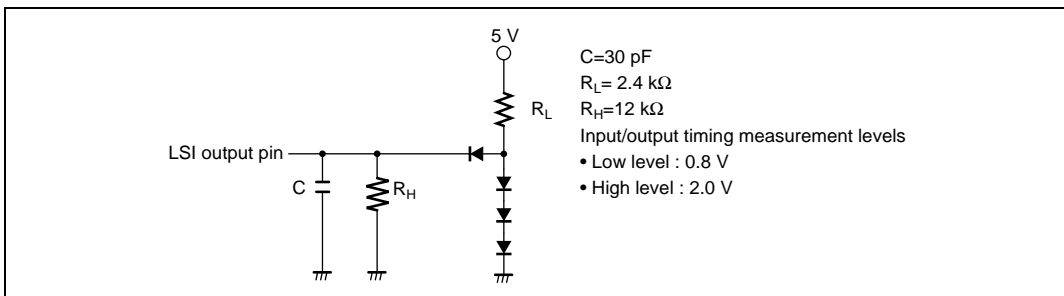
**Figure 23.1 Output Load Circuit**

23.3.1 Clock Timing

Table 23.4 lists the clock timing

Table 23.4 Clock Timing

Conditions : $V_{CC} = 4.5\text{ V to }5.5\text{ V}$, $AV_{CC} = 4.5\text{ V to }5.5\text{ V}$, $V_{SS} = AV_{SS} = 0\text{ V}$,
 $\phi = 4\text{ MHz to }24\text{ MHz}$, $T_a = -20^\circ\text{C to }+75^\circ\text{C}$ (regular specifications),
 $T_a = -40^\circ\text{C to }+85^\circ\text{C}$ (wide-range specifications)

Item	Symbol	Min	Max	Unit	Test Conditions
Clock cycle time	t_{cyc}	41.6	250	ns	Figure 23.2
Clock high pulse width	t_{CH}	8	—	ns	
Clock low pulse width	t_{CL}	8	—	ns	
Clock rise time	t_{Cr}	—	13	ns	
Clock fall time	t_{Cf}	—	13	ns	
Oscillation settling time at reset (crystal)	t_{OSC1}	20	—	ms	Figure 23.3
Oscillation settling time in software standby (crystal)	t_{OSC2}	8	—	ms	Figure 21.3
External clock output settling delay time	t_{DEXT}	2	—	ms	Figure 23.3

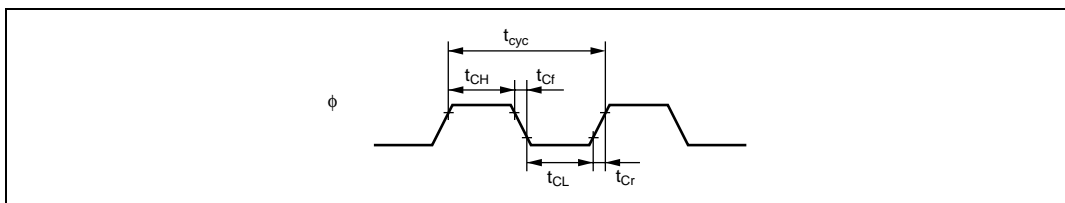

Figure 23.2 System Clock Timing

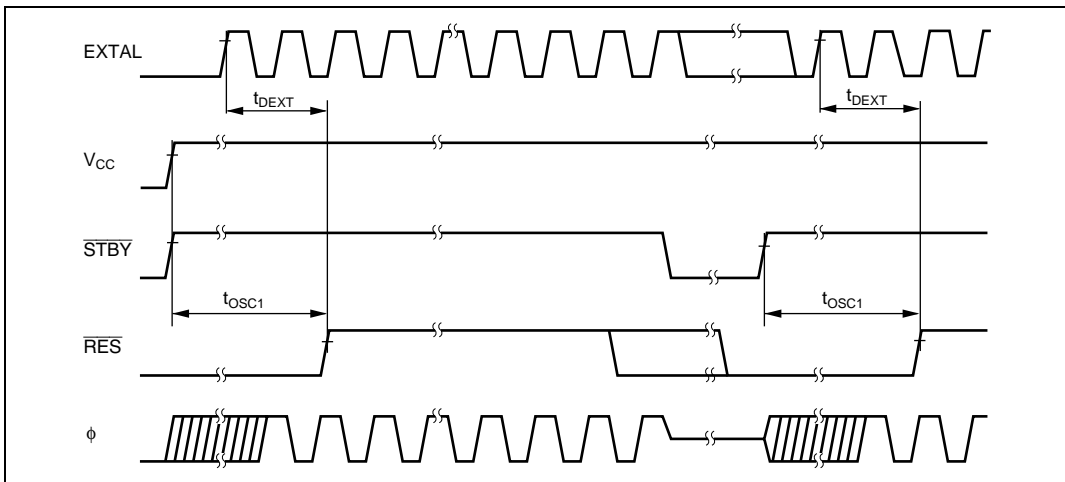

Figure 23.3 Oscillation Settling Timing

23.3.2 Control Signal Timing

Table 23.5 lists the control signal timing.

Table 23.5 Control Signal Timing

Conditions: $V_{CC} = 4.5\text{ V to }5.5\text{ V}$, $AV_{CC} = 4.5\text{ V to }5.5\text{ V}$, $V_{SS} = AV_{SS} = 0\text{ V}$,
 $\phi = 4\text{ MHz to }24\text{ MHz}$, $T_a = -20^\circ\text{C to }+75^\circ\text{C}$ (regular specifications),
 $T_a = -40^\circ\text{C to }+85^\circ\text{C}$ (wide-range specifications)

Item	Symbol	Min	Max	Unit	Test Conditions
$\overline{\text{RES}}$ setup time	t_{RESS}	200	—	ns	Figure 23.4
$\overline{\text{RES}}$ pulse width	t_{RESW}	20	—	t_{cyc}	
NMI setup time	t_{NMIS}	150	—	ns	Figure 23.5
NMI hold time	t_{NMIH}	10	—	ns	
NMI pulse width (exiting software standby mode)	t_{NMIW}	200	—	ns	
$\overline{\text{IRQ}}$ setup time	t_{IRQS}	150	—	ns	
$\overline{\text{IRQ}}$ hold time	t_{IRQH}	10	—	ns	
$\overline{\text{IRQ}}$ pulse width (exiting software standby mode)	t_{IRQW}	200	—	ns	

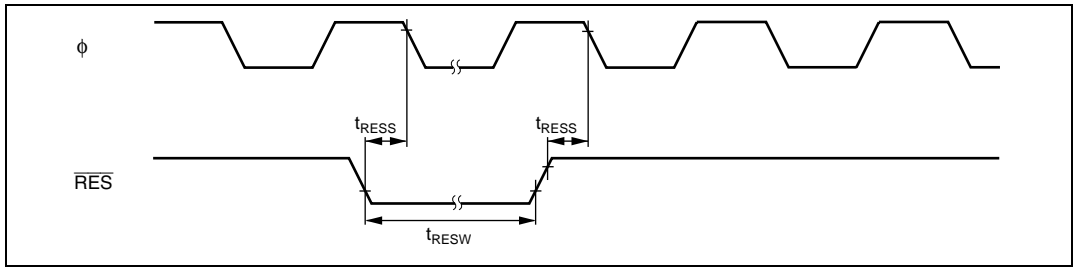

Figure 23.4 Reset Input Timing

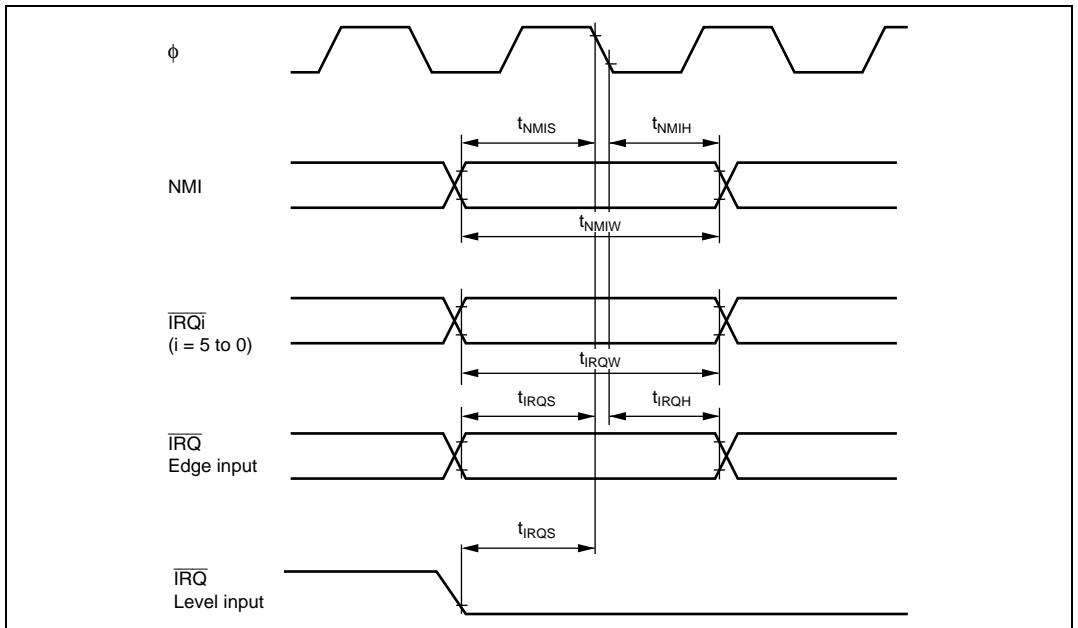

Figure 23.5 Interrupt Input Timing

23.3.3 Timing of On-Chip Peripheral Modules

Table 23.6 lists the timing of on-chip peripheral modules.

Table 23.6 Timing of On-Chip Peripheral Modules

Conditions: $V_{CC} = 4.5\text{ V to }5.5\text{ V}$, $AV_{CC} = 4.5\text{ V to }5.5\text{ V}$, $V_{SS} = AV_{SS} = 0$, $\phi = 4\text{ MHz to }24\text{ MHz}$,

$T_a = -20^\circ\text{C to }+75^\circ\text{C}$ (regular specifications), $T_a = -40^\circ\text{C to }+85^\circ\text{C}$ (wide-range specifications)

Item		Symbol	Min	Max	Unit	Test Conditions	
I/O port	Output data delay time	t_{PWD}	—	40	ns	Figure 23.6	
	Input data setup time	t_{PRS}	25	—			
	Input data hold time	t_{PRH}	25	—			
	Realtime input port data hold time	t_{RTIPH}	4	—	t_{cyc}	Figure 23.7	
TPU	Timer output delay time	t_{TOCD}	—	40	ns	Figure 23.8	
	Timer input setup time	t_{TICS}	25	—			
	Timer clock input setup time	t_{TCKS}	25	—	ns	Figure 23.9	
	Timer clock pulse width	Single edge	t_{TCKWH}	1.5	—		t_{cyc}
Both edges		t_{TCKWL}	2.5	—			
SCI	Input clock cycle	Asynchronous	t_{Scyc}	4	—	t_{cyc}	Figure 23.10
		Synchronous		6	—		
	Input clock pulse width	t_{SCKW}	0.4	0.6	t_{Scyc}		
	Input clock rise time	t_{SCKr}	—	1.5	t_{cyc}		
	Input clock fall time	t_{SCKf}	—	1.5			
	Transmit data delay time	t_{TXD}	—	40	ns	Figure 23.11	
	Receive data setup time (synchronous)	t_{RXS}	40	—			
Receive data hold time (synchronous)	t_{RXH}	40	—				

Item		Symbol	Min	Max	Unit	Test Conditions
A/D converter	Trigger input setup time	t_{TRGS}	30	—	ns	Figure 23.12
HCAN*	Transmit data delay time	t_{HTXD}	—	80	ns	Figure 23.13
	Receive data setup time	t_{HRXS}	80	—		
	Receive data hold time	t_{HRXH}	80	—		
PPG	Pulse output delay time	t_{POD}	—	40	ns	Figure 23.14
TMR	Timer output delay time	t_{TMOD}	—	40	ns	Figure 23.15
	Timer reset input setup time	t_{TMRS}	25	—	ns	Figure 23.17
	Timer clock input setup time	t_{TMCS}	25	—	ns	Figure 23.16
	Timer clock pulse width	Single edge	t_{TMCWH}	1.5	—	t_{CYC}
Both edges		t_{TMCWL}	2.5	—		

Note: * The HCAN input signal is asynchronous. However, its state is judged to have changed at the rising-edge (two clock cycles) of the ϕ clock signal shown in figure 23.13. The HCAN output signal is also asynchronous. Its state changes based on the rising-edge (two clock cycles) of the ϕ clock signal shown in figure 23.13.

Table 23.7 Timing of SSU

Conditions: $V_{CC} = 4.5 \text{ V to } 5.5 \text{ V}$, $AV_{CC} = 4.5 \text{ V to } 5.5 \text{ V}$, $V_{SS} = AV_{SS} = 0$, $\phi = 4 \text{ MHz to } 24 \text{ MHz}$,

$T_a = -20^\circ\text{C to } +75^\circ\text{C}$ (regular specifications), $T_a = -40^\circ\text{C to } +85^\circ\text{C}$ (wide-range specifications)

Item			Symbol	Min	Max	Unit	Test Conditions
SSU	Clock cycle	Master	t_{SUCYC}	2	256	t_{CYC}	Figure 23.18 Figure 23.19
		Slave		4	256		
	Clock high level pulse width	Master	t_{HI}	20	—	ns	Figure 23.20 Figure 23.21
		Slave		60	—		
	Clock low level pulse width	Master	t_{LO}	20	—	ns	
		Slave		60	—		
	Clock rise time		t_{RISE}	—	20	ns	
	Clock fall time		t_{FALL}	—	20	ns	
	Data input setup time	Master	t_{SU}	30	—	ns	
		Slave		30	—		
	Data input hold time	Master	t_H	10	—	ns	
		Slave		10	—		
	SCS setup time	Master	t_{LEAD}	1.5	—	t_{CYC}	
		Slave		1.5	—		
	SCS hold time	Master	t_{LAG}	1.5	—	t_{CYC}	
		Slave		1.5	—		
	Data output delay time	Master	t_{OD}	—	40	ns	
		Slave		—	40		
	Data output hold time	Master	t_{OH}	30	—	ns	
		Slave		30	—		
	Continuous transmit delay time	Master	t_{TD}	1.5	—	t_{CYC}	
		Slave		1.5	—		
	Slave access time		t_{SA}	—	1	t_{CYC}	
	Slave out release time		t_{REL}	—	1	t_{CYC}	

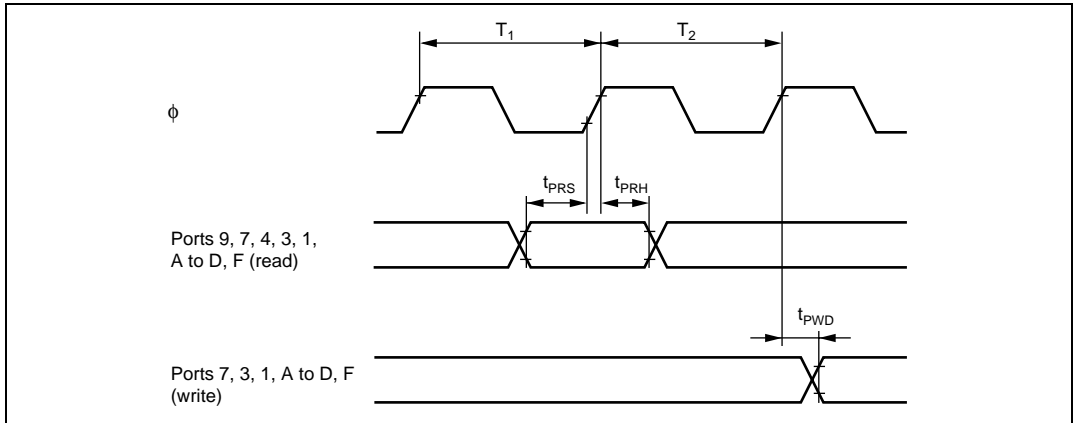

Figure 23.6 I/O Port Input/Output Timing

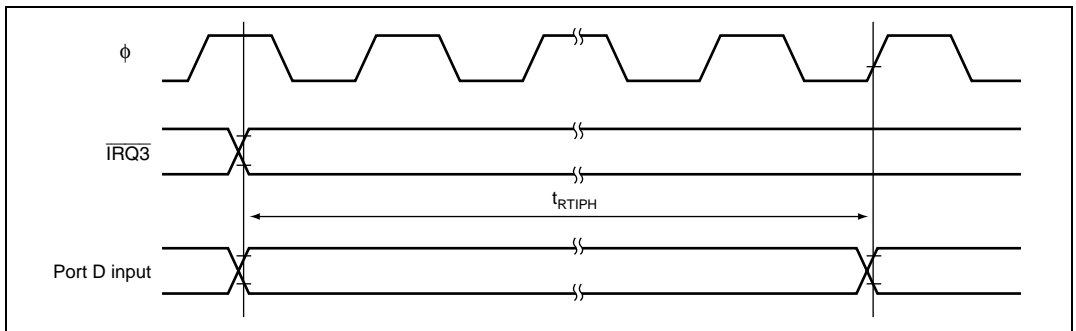

Figure 23.7 Realtime Input Port Data Input Timing

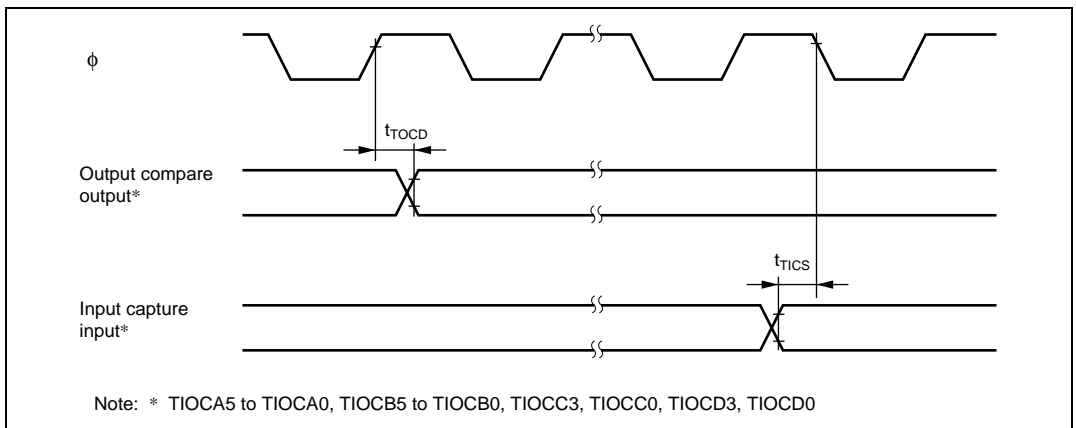

Figure 23.8 TPU Input/Output Timing

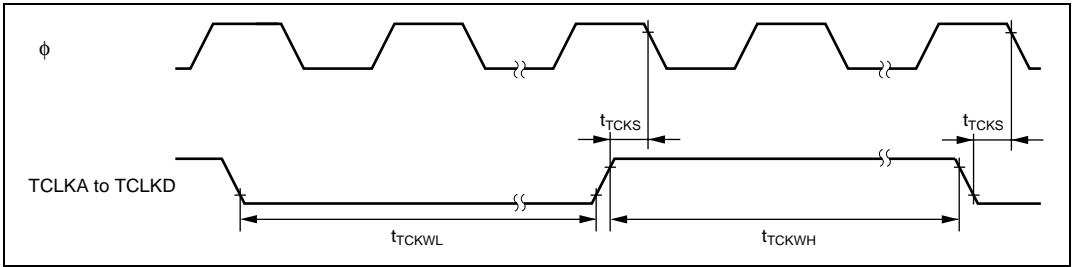

Figure 23.9 TPU Clock Input Timing

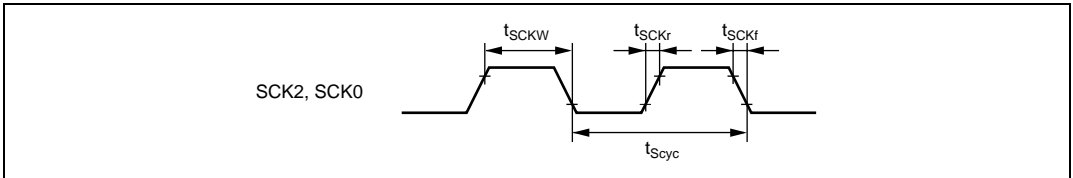

Figure 23.10 SCK Clock Input Timing

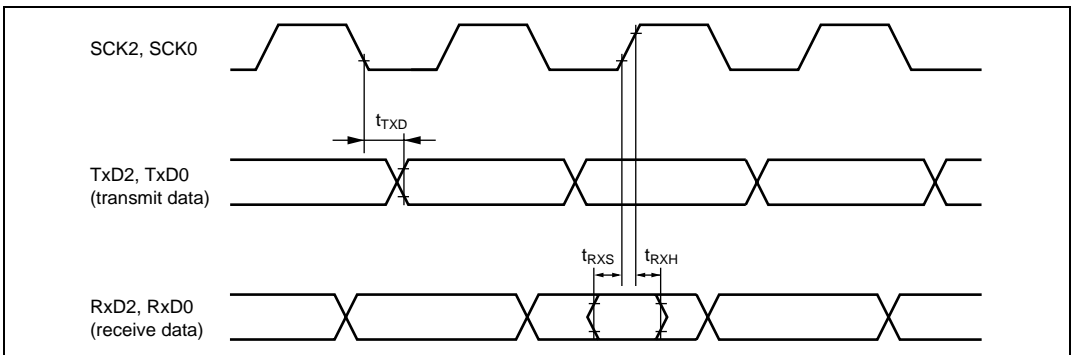

Figure 23.11 SCI Input/Output Timing (Clocked Synchronous Mode)

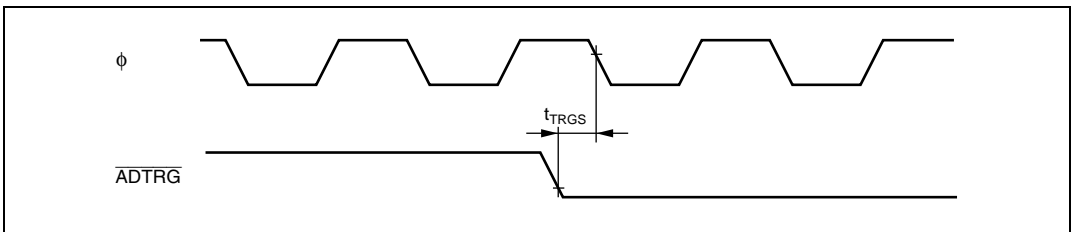
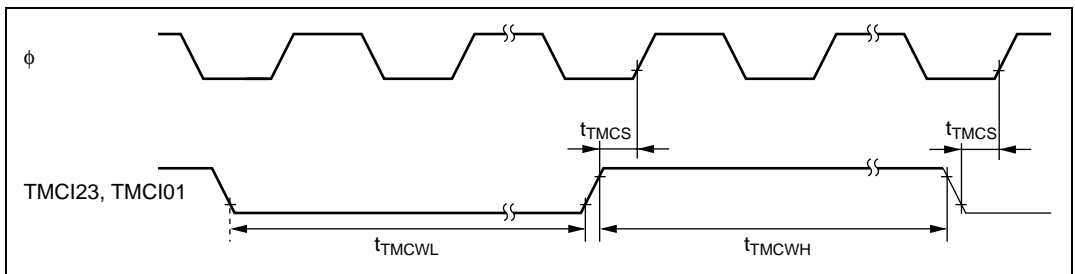
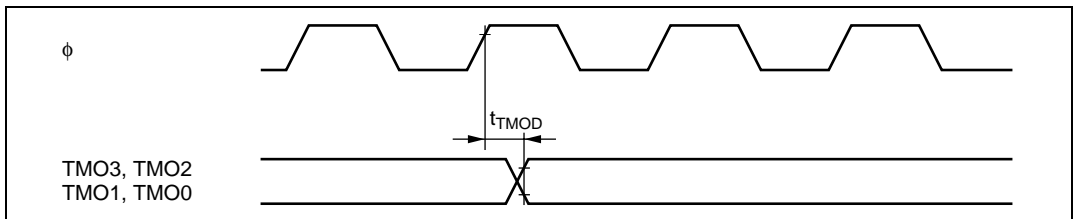
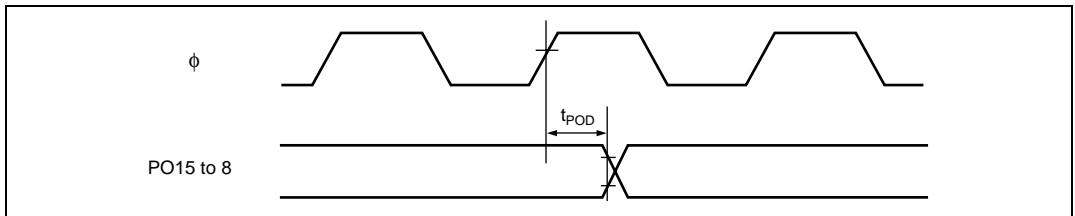
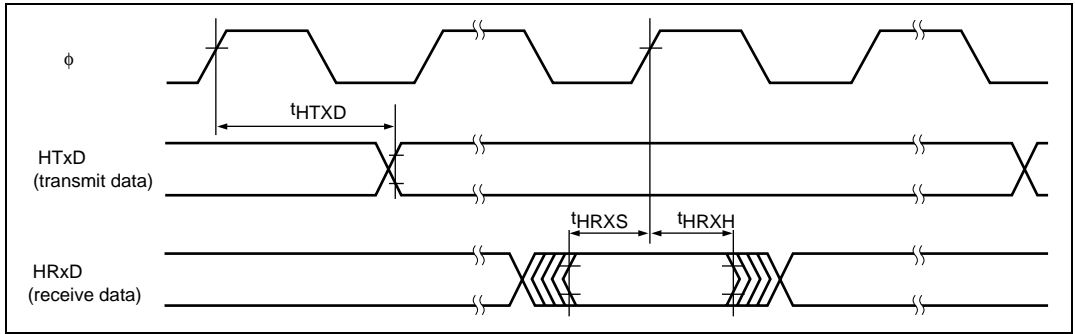

Figure 23.12 A/D Converter External Trigger Input Timing



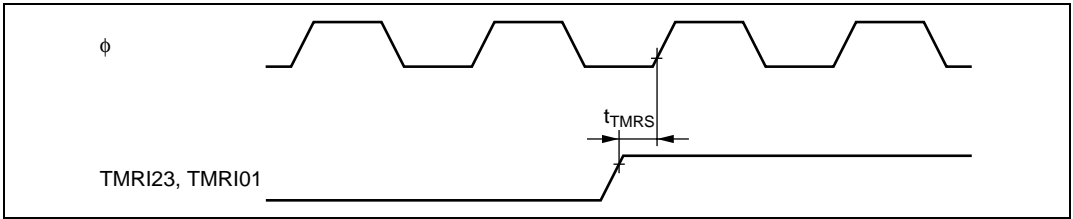

Figure 23.17 8-Bit Timer Reset Input Timing

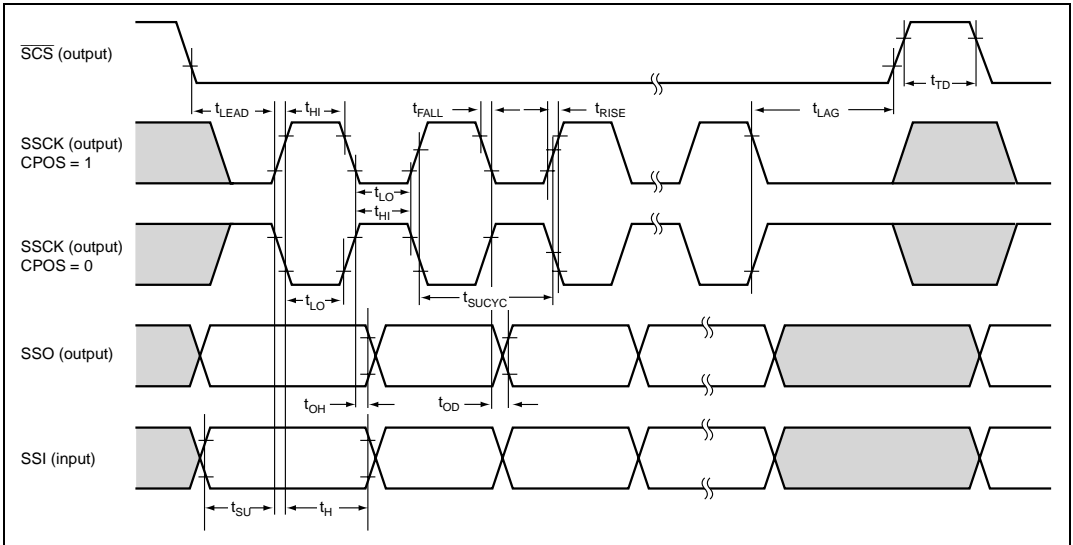

Figure 23.18 SSU Timing (Master, CPHS = 1)

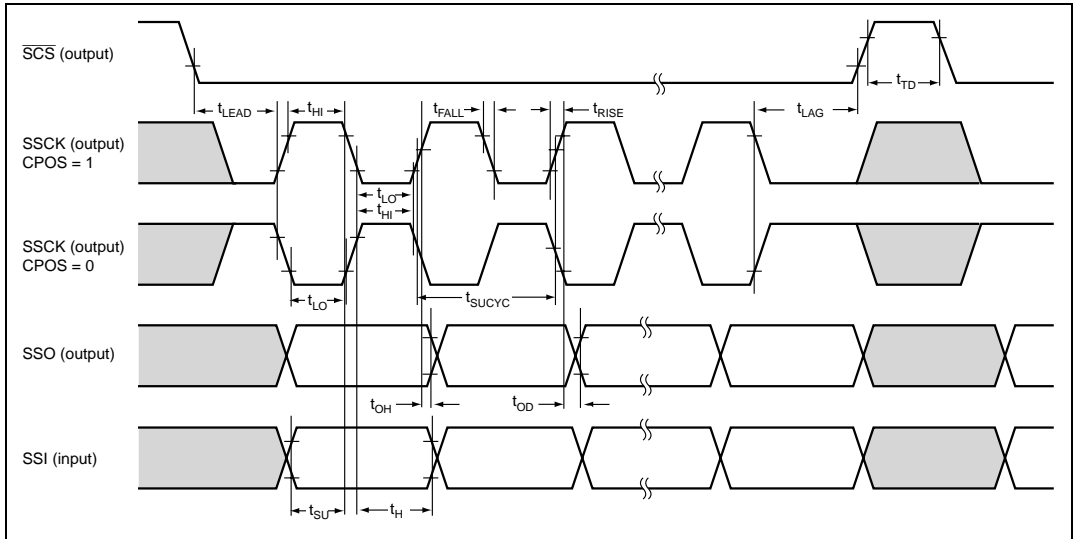

Figure 23.19 SSU Timing (Master, CPHS = 0)

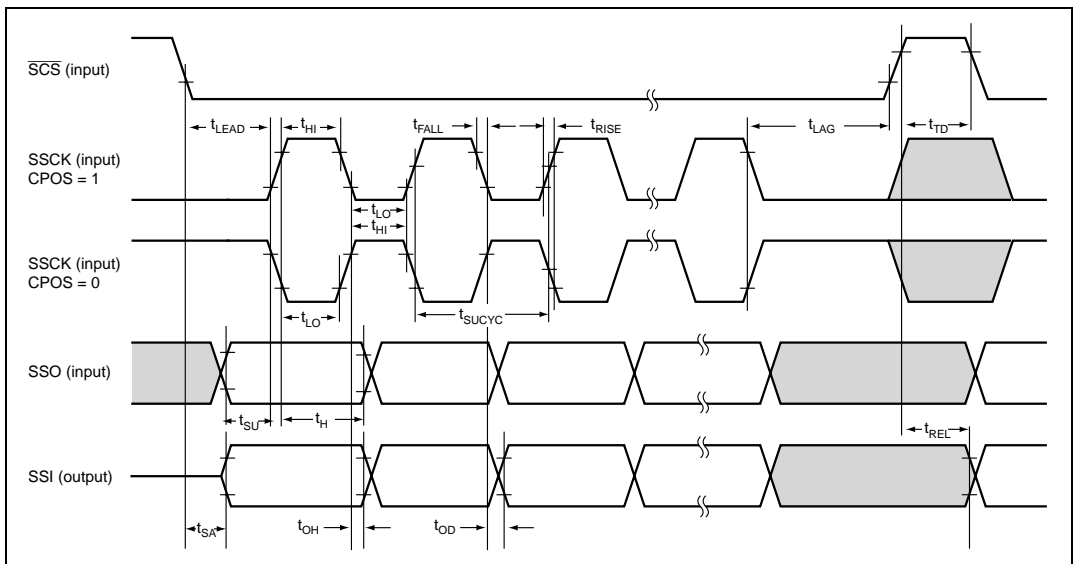

Figure 23.20 SSU Timing (Slave, CPHS = 1)

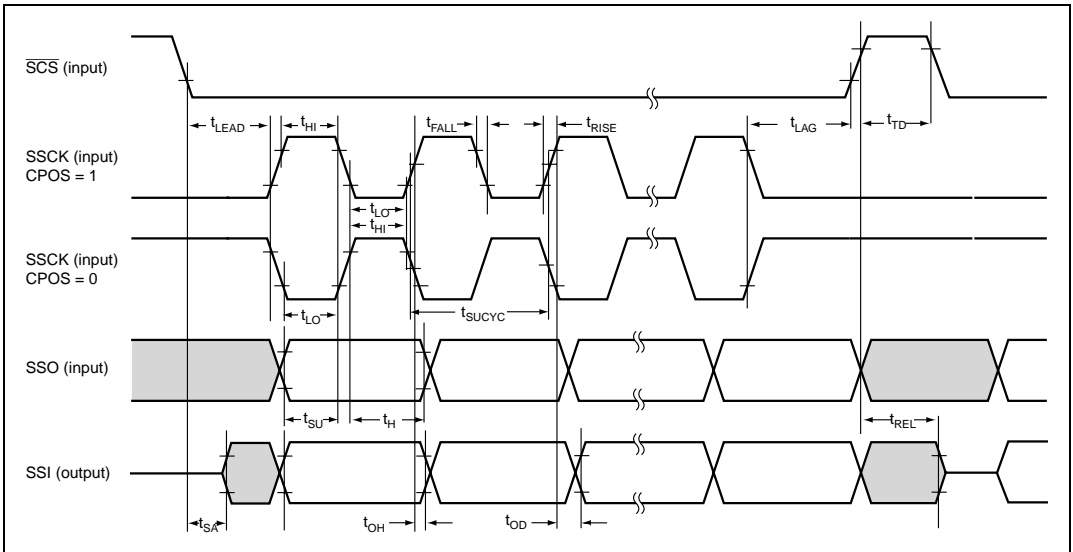

Figure 23.21 SSU Timing (Slave, CPHS = 0)

23.4 A/D Conversion Characteristics

Table 23.8 lists the A/D conversion characteristics.

Table 23.8 A/D Conversion Characteristics

Conditions: $V_{CC} = 4.5\text{ V to }5.5\text{ V}$, $AV_{CC} = 4.5\text{ V to }5.5\text{ V}$, $V_{SS} = AV_{SS} = 0\text{ V}$,
 $\phi = 4\text{ MHz to }24\text{ MHz}$, $T_a = -20^\circ\text{C to }+75^\circ\text{C}$ (regular specifications),
 $T_a = -40^\circ\text{C to }+85^\circ\text{C}$ (wide-range specifications)

Item	Min	Typ	Max	Unit
Resolution	10	10	10	bits
Conversion time	10	—	200	μs
Analog input capacitance	—	—	20	pF
Permissible signal-source impedance	—	—	5	$\text{k}\Omega$
Nonlinearity error	—	—	± 3.5	LSB
Offset error	—	—	± 3.5	LSB
Full-scale error	—	—	± 3.5	LSB
Quantization	—	± 0.5	—	LSB
Absolute accuracy	—	—	± 4.0	LSB

23.5 Flash Memory Characteristics

Table 23.9 lists the flash memory characteristics.

Table 23.9 Flash Memory Characteristics

Conditions: $V_{CC} = 4.5\text{ V to }5.5\text{ V}$, $AV_{CC} = 4.5\text{ V to }5.5\text{ V}$,

$V_{SS} = PLLV_{SS} = AV_{SS} = 0\text{ V}$,

$T_a = 0\text{ to }+75^\circ\text{C}$ (Programming/erasing operating temperature range)

Item	Symbol	Min	Typ	Max	Unit	Test Condition	
Programming time ^{*1*2*4}	t_P	—	10	200	ms/ 128 bytes		
Erase time ^{*1*3*5}	t_E	—	100	1200	ms/block		
Reprogramming count	N_{WEC}	—	—	100	Times		
Programming	Wait time after SWE bit setting ^{*1}	t_{SSWE}	1	1	—	μs	
	Wait time after PSU1 bit setting ^{*1}	t_{SPSU}	50	50	—	μs	
	Wait time after P1 bit setting ^{*1*4}	t_{SP30}	28	30	32	μs	Programming time wait
		t_{SP200}	198	200	202	μs	Programming time wait
		t_{SP10}	8	10	12	μs	Additional- programming time wait
	Wait time after P1 bit clear ^{*1}	t_{CP}	5	5	—	μs	
	Wait time after PSU1 bit clear ^{*1}	t_{CPSU}	5	5	—	μs	
	Wait time after PV1 bit setting ^{*1}	t_{SPV}	4	4	—	μs	
	Wait time after H'FF dummy write ^{*1}	t_{SPVR}	2	2	—	μs	
	Wait time after PV1 bit clear ^{*1}	t_{CPV}	2	2	—	μs	
Wait time after SWE bit clear ^{*1}	t_{CSWE}	100	100	—	μs		
Maximum programming count ^{*1*4}	N	—	—	1000	Times		
Erase	Wait time after SWE bit setting ^{*1}	t_{SSWE}	1	1	—	μs	
	Wait time after ESU1 bit setting ^{*1}	t_{SESU}	100	100	—	μs	
	Wait time after E1 bit setting ^{*1*5}	t_{SE}	10	10	100	ms	Erase time wait
	Wait time after E1 bit clear ^{*1}	t_{CE}	10	10	—	μs	
	Wait time after ESU1 bit clear ^{*1}	t_{CESU}	10	10	—	μs	
	Wait time after EV1 bit setting ^{*1}	t_{SEV}	20	20	—	μs	
	Wait time after H'FF dummy write ^{*1}	t_{SEVR}	2	2	—	μs	
	Wait time after EV1 bit clear ^{*1}	t_{CEV}	4	4	—	μs	
	Wait time after SWE bit clear ^{*1}	t_{CSWE}	100	100	—	μs	
Maximum erase count ^{*1*5}	N	12	—	120	Times		

- Notes:
1. Make each time setting in accordance with the program/program-verify flowchart or erase/erase-verify flowchart.
 2. Programming time per 128 bytes (shows the total period for which the P1 bit in the flash memory control register (FLMCR1) is set. It does not include the programming verification time.)
 3. Block erase time (shows the total period for which the E1-bit FLMCR1 is set. It does not include the erase verification time.)
 4. To specify the maximum programming time value (t_p (max)) in the 128-bytes programming algorithm, set the max. value (1000) for the maximum programming count (n).

The wait time after P1 bit setting should be changed as follows according to the value of the programming counter (n).

Programming counter (n) = 1 to 6: $t_{sp30} = 30 \mu\text{s}$

Programming counter (n) = 7 to 1000: $t_{sp200} = 200 \mu\text{s}$

[In additional programming]

Programming counter (n) = 1 to 6: $t_{sp10} = 10 \mu\text{s}$

5. For the maximum erase time (t_E (max)), the following relationship applies between the wait time after E1 bit setting (t_{se}) and the maximum erase count (N):

$$t_E \text{ (max)} = \text{Wait time after E1 bit setting } (t_{se}) \times \text{maximum erase count } (N)$$

To set the maximum erase time, the values of (t_{se}) and (N) should be set so as to satisfy the above formula.

Examples: When $t_{se} = 100 \text{ ms}$, $N = 12$ times

When $t_{se} = 10 \text{ ms}$, $N = 120$ times

Appendix

A. I/O Port States in Each Pin State

Port Name	MCU Operating Mode	Reset	Hardware Standby Mode	Software Standby Mode	Program Execution State Sleep Mode
Port 1	7	T	T	Keep	I/O port
Port 3	7	T	T	Keep	I/O port
Port 4	7	T	T	T	Input port
Port 7	7	T	T	Keep	I/O port
Port 9	7	T	T	T	Input port
Port A	7	T	T	Keep	I/O port
Port B	7	T	T	Keep	I/O port
Port C	7	T	T	Keep	I/O port
Port D	7	T	T	Keep	I/O port
PF7	7	T	T	[DDR = 0] T [DDR = 1] H	[DDR = 0] T [DDR = 1] Clock output
PF6	7	T	T	Keep	I/O port
PF5					
PF4					
PF3					
PF2					
PF1					
PF0					
HTxD	7	H	T	H	Output
HRxD	7	Input	T	T	Input

Legend:

H: High level

T: High impedance

Keep: Input port becomes high-impedance, output port retains state

B. Product Code Lineup

Product Type		Type Name		Package (Package Code)
H8S/2628	F-ZTAT version	Standard product	HD64F2628	QFP-100 (FP-100M)
	Masked ROM version	Standard product	HD6432628	
H8S/2627	Masked ROM version	Standard product	HD6432627	

C. Package Dimensions

The package dimension that is shown in the Renesas Technology Semiconductor Package Data Book has priority.

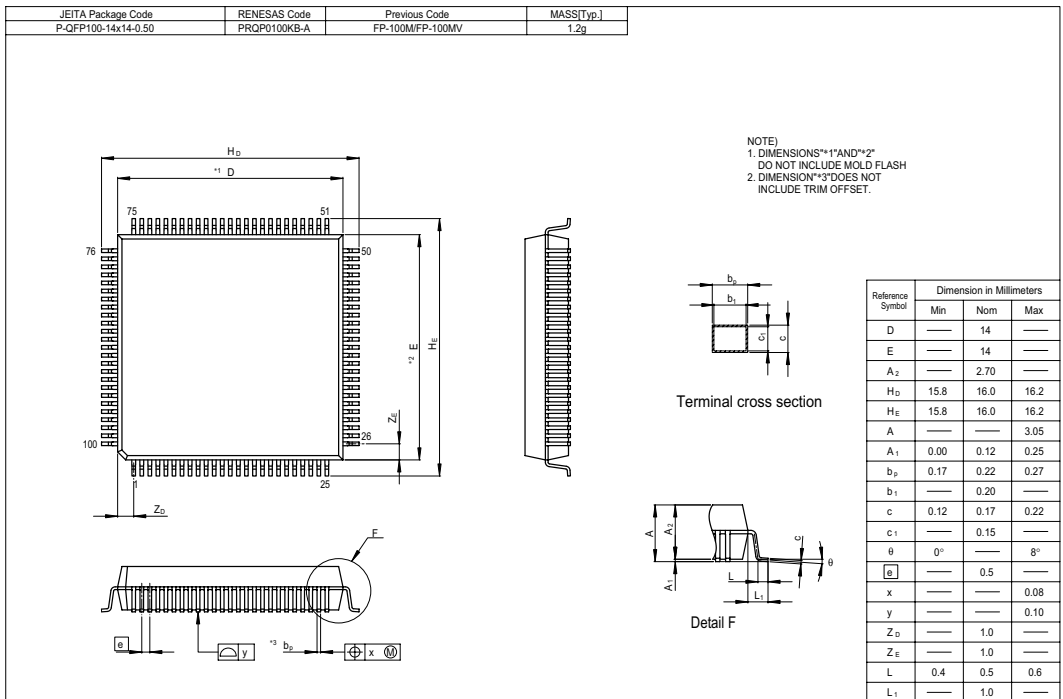

Figure C.1 FP-100M Package Dimensions

Index

- 16-Bit Timer Pulse Unit (TPU) 167
 - Buffer Operation..... 212
 - Cascaded Operation..... 217
 - Free-running count operation 206
 - Input Capture..... 209
 - periodic count operation 206
 - Phase Counting Mode 224
 - PWM Modes 219
 - Synchronous Operation 211
 - toggle output..... 207
 - Waveform Output by Compare Match
..... 207
- 8-Bit Timers 251
 - 16-Bit Count Mode..... 267
 - Cascaded Connection 267
 - Compare-Match Count Mode..... 267
 - Pulse Output 262
 - TCNT Incrementation Timing..... 263
 - Toggle output 271
- A/D Converter 449
 - A/D Converter Activation 233
 - A/D trigger input 165
 - Conversion Time 457
 - External Trigger..... 459
 - Scan Mode..... 456
 - Single Mode 456
- Address Map..... 53
- Address Space 18
- Addressing Modes 39
 - Absolute Address 41
 - Immediate..... 42
 - Memory Indirect..... 42
 - Program-Counter Relative..... 42
 - Register Direct..... 40
 - Register Indirect 40
 - Register Indirect with Displacement . 40
 - Register Indirect with Post-Increment41
 - Register Indirect with Pre-Decrement 41
- Bcc 27, 36
- Bit Rate 403
- break address 87, 90
- break conditions..... 90
- Bus Arbitration 99
- bus cycle 95
- Bus Masters 99
- Clock Pulse Generator 491
- Condition Field 38
- Condition-Code Register (CCR)..... 22
- CPU Operating Modes..... 14
 - Advanced Mode..... 15
 - Normal Mode..... 14
- data direction register..... 127
- data register..... 127
- Data Transfer Controller..... 101
 - Activation by Software 121
 - Block Transfer Mode 115
 - Chain Transfer 117, 123
 - DTC Vector Table 109
 - Normal Mode..... 113, 122
 - Register Information..... 109
 - Repeat Mode..... 114
 - software activation..... 118
 - Software Activation 124
 - vector number for the software
activation interrupt..... 107
- Effective Address..... 39, 43
- Effective Address Extension..... 38
- Exception Handling 55
 - Interrupts..... 61
 - Reset Exception Handling 57
 - Stack Status..... 63
 - Traces 60
 - Trap Instruction 62
- Extended Control Register (EXR) 21

Flash memory	467	Interrupt Control Modes	78
Flash Memory		Interrupt Controller	65
Boot Mode	478	Interrupt Exception Handling Vector Table	
Emulation	482	74
Erase/Erase-Verify	486	Interrupt Mask Bit	22
erasing units	472	interrupt mask level	21
Program/Program-Verify	484	interrupt priority register (IPR)	65
programming units	472	Interrupts	
Programming/Erasing in User Program		ADI	459
Mode	480	CMIA	268
General Registers	20	CMIB	268
HCAN	97, 371	ERS0/OVR0	416
11 consecutive recessive bits	400	NMI	73
Arbitration field	407, 410	OVI	268
buffer segment	403	RM0	416
Configuration mode	400	RM1	416
Control field	407	SLE0	416
Data field	407	SWDTEND	118
Data frame	410	TCIU_1	232
DTC Interface	417	TCIU_2	232
HCAN Halt Mode	415	TCIU_4	232
HCAN Sleep Mode	412	TCIU_5	232
mailbox	396	TCIV_0	232
Message Control (MC0 to MC15) ...	396	TCIV_1	232
Message Data (MD0 to MD15)	398	TCIV_2	232
Message transmission cancellation..	407	TCIV_3	232
Message Transmission Method	405	TCIV_4	232
Remote frame	411	TCIV_5	232
remote transmission request bit	411	TGIA_0	232
Unread message overwrite	411	TGIA_1	232
input pull-up MOS	127	TGIA_2	232
Instruction Set	27	TGIA_3	232
Arithmetic Operations Instructions ...	30	TGIA_4	232
Bit Manipulation Instructions	34	TGIA_5	232
Block Data Transfer Instructions	38	TGIB_0	232
Branch Instructions	36	TGIB_1	232
Data Transfer Instructions	29	TGIB_2	232
Logic Operations Instructions	32	TGIB_3	232
Shift Instructions	33	TGIB_4	232
System Control Instructions	37	TGIB_5	232

TGIC_0.....	232	EBR2	476, 534, 554, 572
TGIC_3.....	232	FLMCR1.....	473, 534, 554, 572
TGID_0	232	FLMCR2.....	475, 534, 554, 572
TGID_3	232	GSR	375, 518, 536, 556
WOVI.....	301	HCANMON.....	399, 527, 545, 565
MAC instruction.....	51	IER.....	69, 529, 548, 566
memory cycle	95	IMR.....	391, 518, 536, 556
Multiply-Accumulate Register (MAC).....	23	IPR.....	68, 531, 551, 569
On-Board Programming	477	IRR	386, 518, 536, 556
open-drain control register.....	127	ISCR	70, 528, 548, 566
Operating Mode Selection.....	49	ISR.....	72, 529, 548, 566
Operation Field.....	38	LAFMH	394, 518, 537, 556
PC Break Controller	87	LAFML.....	394, 518, 537, 556
Pin Arrangement.....	3	LPWRCR.....	493, 528, 548, 566
PLL Circuit.....	497	MBCR.....	379, 518, 536, 556
port register.....	127	MBIMR	390, 518, 536, 556
Program Counter (PC).....	21	MC.....	396, 518, 537, 556
Program/Erase Protection.....	488	MCR	374, 518, 536, 556
Programmable Pulse Generator	275	MD.....	398, 523, 541, 560
Non-Overlapping Pulse Output	288	MDCR	50, 528, 548, 566
output trigger	282	MRA	104
Programmer Mode.....	489	MRB	105
Register Field.....	38	MSTPCR	506, 528, 548, 566
Registers		NDER	278, 529, 549, 567
ABACK.....	383, 518, 536, 556	NDR.....	280, 529, 549, 567
ADCR.....	455, 534, 554, 572	P1DDR	131, 529, 549, 567
ADCSR.....	453, 534, 554, 572	P1DR	132, 531, 551, 569
ADDR.....	452, 534, 554, 572	PADDR.....	145, 529, 549, 567
BARA.....	88, 528, 548, 566	PADR.....	146, 532, 551, 569
BARB.....	89, 528, 548, 566	PAODR.....	147, 530, 550, 568
BCR.....	377, 518, 536, 556	PAPCR	147, 529, 549, 567
BCRA.....	89, 528, 548, 566	PBDDR.....	149, 529, 549, 567
BCRB	90, 528, 548, 566	PBDR.....	150, 532, 552, 569
BRR.....	323, 534, 553, 571	PBODR.....	151, 530, 550, 568
CRA.....	105	PBPCR.....	151, 529, 549, 567
CRB.....	106	PCDDR.....	154, 529, 549, 567
DAR.....	105	PCDR.....	155, 532, 552, 570
DTCER.....	106, 529, 549, 567	PCODR.....	156, 530, 550, 568
DTVECR.....	107, 529, 549, 567	PCPCR.....	156, 530, 549, 567
EBR1	475, 534, 554, 572	PCR.....	282, 529, 549, 567

PDDDR	160, 529, 549, 567	TCNTH.....	552
PDDR	161, 532, 552, 570	TCOR	254, 528, 547, 566
PDPCR	162, 530, 549, 567	TCR	255, 528, 547, 566
PFDDR	163, 529, 549, 567	TCSR	257, 528, 547, 566
PFDR	164, 532, 552, 570	TDR	308, 534, 553, 571
PMR	283, 529, 549, 567	TEC.....	392, 518, 536, 556
PODR	279, 529, 549, 567	TGR	213, 530, 550, 568
PORT1.....	132, 534, 554, 572	TIER	198, 530, 550, 568
PORT4.....	140, 534, 554, 572	TIOR.....	181, 530, 550, 568
PORT9.....	144, 535, 554, 572	TMDR.....	179, 530, 550, 568
PORTA.....	146, 535, 555, 572	TSR.....	308, 530, 550, 568
PORTB.....	150, 535, 555, 572	TSTR	203, 531, 551, 569
PORTC.....	155, 535, 555, 572	TSYR.....	204, 531, 551, 569
PORTD.....	161, 535, 555, 572	TXACK	382, 518, 536, 556
PORTF	164, 535, 555, 572	TXCR	381, 518, 536, 556
RAMER.....	476, 531, 551, 569	TXPR.....	380, 518, 536, 556
RDR.....	308, 534, 554, 571	UMSR.....	393, 518, 537, 556
REC	392, 518, 536, 556	Reset	57
RFPR	385, 518, 536, 556	Serial Communication Interface	305
RSR	308	Asynchronous Mode.....	330
RSTCSR	299, 533, 553, 571	bit rate.....	323
RXPR	384, 518, 536, 556	Break.....	370
SAR	105	framing error.....	337
SBYCR.....	504, 528, 548, 566	Mark State.....	370
SCKCR.....	492, 528, 548, 566	overrun error	337
SCMR.....	322, 534, 554, 571	parity error	337
SCR	313, 534, 553, 571	stack pointer (SP).....	20
SMR	309, 534, 553, 571	Time Quanta (TQ)	404
SSR.....	316, 534, 553, 571	Trace Bit	21
SYSCR	51, 528, 548, 566	TRAPA instruction	42, 62
TCNT	203, 254, 296, 532, 533, 550, 553, 571	Watchdog Timer	295
		Interval Timer Mode.....	300

**Renesas 16-Bit Single-Chip Microcomputer
Hardware Manual
H8S/2628 Group**

Publication Date: 1st Edition, September 2002
Rev.3.00, October 04, 2005

Published by: Sales Strategic Planning Div.
Renesas Technology Corp.

Edited by: Customer Support Department
Global Strategic Communication Div.
Renesas Solutions Corp.

Renesas Technology Corp. Sales Strategic Planning Div. Nippon Bldg., 2-6-2, Ohte-machi, Chiyoda-ku, Tokyo 100-0004, Japan



RENESAS SALES OFFICES

<http://www.renesas.com>

Refer to "<http://www.renesas.com/en/network>" for the latest and detailed information.

Renesas Technology America, Inc.

450 Holger Way, San Jose, CA 95134-1368, U.S.A
Tel: <1> (408) 382-7500, Fax: <1> (408) 382-7501

Renesas Technology Europe Limited

Dukes Meadow, Millboard Road, Bourne End, Buckinghamshire, SL8 5FH, United Kingdom
Tel: <44> (1628) 585-100, Fax: <44> (1628) 585-900

Renesas Technology Hong Kong Ltd.

7th Floor, North Tower, World Finance Centre, Harbour City, 1 Canton Road, Tsimshatsui, Kowloon, Hong Kong
Tel: <852> 2265-6688, Fax: <852> 2730-6071

Renesas Technology Taiwan Co., Ltd.

10th Floor, No.99, Fushing North Road, Taipei, Taiwan
Tel: <886> (2) 2715-2888, Fax: <886> (2) 2713-2999

Renesas Technology (Shanghai) Co., Ltd.

Unit2607 Ruijing Building, No.205 Maoming Road (S), Shanghai 200020, China
Tel: <86> (21) 6472-1001, Fax: <86> (21) 6415-2952

Renesas Technology Singapore Pte. Ltd.

1 Harbour Front Avenue, #06-10, Keppel Bay Tower, Singapore 098632
Tel: <65> 6213-0200, Fax: <65> 6278-8001

Renesas Technology Korea Co., Ltd.

Kukje Center Bldg. 18th Fl., 191, 2-ka, Hangang-ro, Yongsan-ku, Seoul 140-702, Korea
Tel: <82> 2-796-3115, Fax: <82> 2-796-2145

Renesas Technology Malaysia Sdn. Bhd.

Unit 906, Block B, Menara Amcorp, Amcorp Trade Centre, No.18, Jalan Persiaran Barat, 46050 Petaling Jaya, Selangor Darul Ehsan, Malaysia
Tel: <603> 7955-9390, Fax: <603> 7955-9510

H8S/2628 Group Hardware Manual



Renesas Technology Corp.

2-6-2, Ote-machi, Chiyoda-ku, Tokyo, 100-0004, Japan