

Silicon NPN Power Transistors

2SC4663

DESCRIPTION

- With ITO-220 package
- Switching power transistor

PINNING

PIN	DESCRIPTION
1	Base
2	Collector
3	Emitter

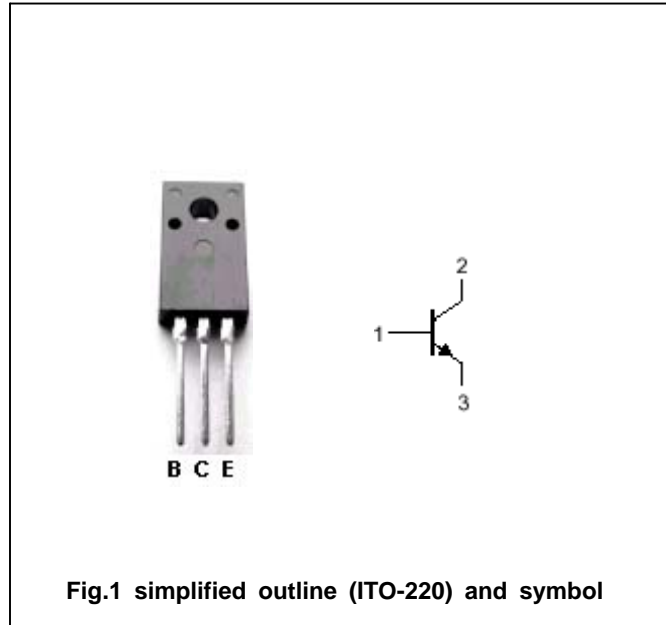

Absolute maximum ratings(Ta=25)

SYMBOL	PARAMETER	CONDITIONS	VALUE	UNIT
V _{CB0}	Collector-base voltage	Open emitter	250	V
V _{CEO}	Collector-emitter voltage	Open base	200	V
V _{EBO}	Emitter-base voltage	Open collector	7	V
I _C	Collector current		5	A
I _{CM}	Collector current-Peak		10	A
I _B	Base current		2	A
I _{BM}	Base current-Peak		4	A
P _T	Total power dissipation	T _C =25	25	W
T _j	Junction temperature		150	
T _{stg}	Storage temperature		-55~150	

THERMAL CHARACTERISTICS

SYMBOL	PARAMETER	MAX	UNIT
R _{th j-C}	Thermal resistance junction case	5.0	/W

Silicon NPN Power Transistors

2SC4663

CHARACTERISTICS

T_j=25 unless otherwise specified

SYMBOL	PARAMETER	CONDITIONS	MIN	TYP.	MAX	UNIT
V _{CEO(SUS)}	Collector-emitter sustaining voltage	I _C =0.1A ; I _B =0	200			V
V _{CEsat}	Collector-emitter saturation voltage	I _C =2.5A; I _B =0.5A			1.0	V
V _{BEsat}	Emitter-base saturation voltage	I _C =2.5A; I _B =0.5A			1.5	V
I _{CBO}	Collector cut-off current	At rated volatge			0.1	mA
I _{CEO}					0.1	mA
I _{EBO}	Emitter cut-off current	At rated volatge			0.1	mA
h _{FE-1}	DC current gain	I _C =2.5A ; V _{CE} =2V	10		25	
h _{FE-2}	DC current gain	I _C =1mA ; V _{CE} =2V	10			
f _T	Transition frequency	I _C =0.5A ; V _{CE} =10V		13		MHz
t _{on}	Turn-on time	I _C =2.5A; I _{B1} =0.5A I _{B2} =1A , R _L =60 V _{BB2} =4V			0.3	μs
t _s	Storage time				1.0	μs
t _f	Fall time				0.1	μs

Silicon NPN Power Transistors

2SC4663

PACKAGE OUTLINE

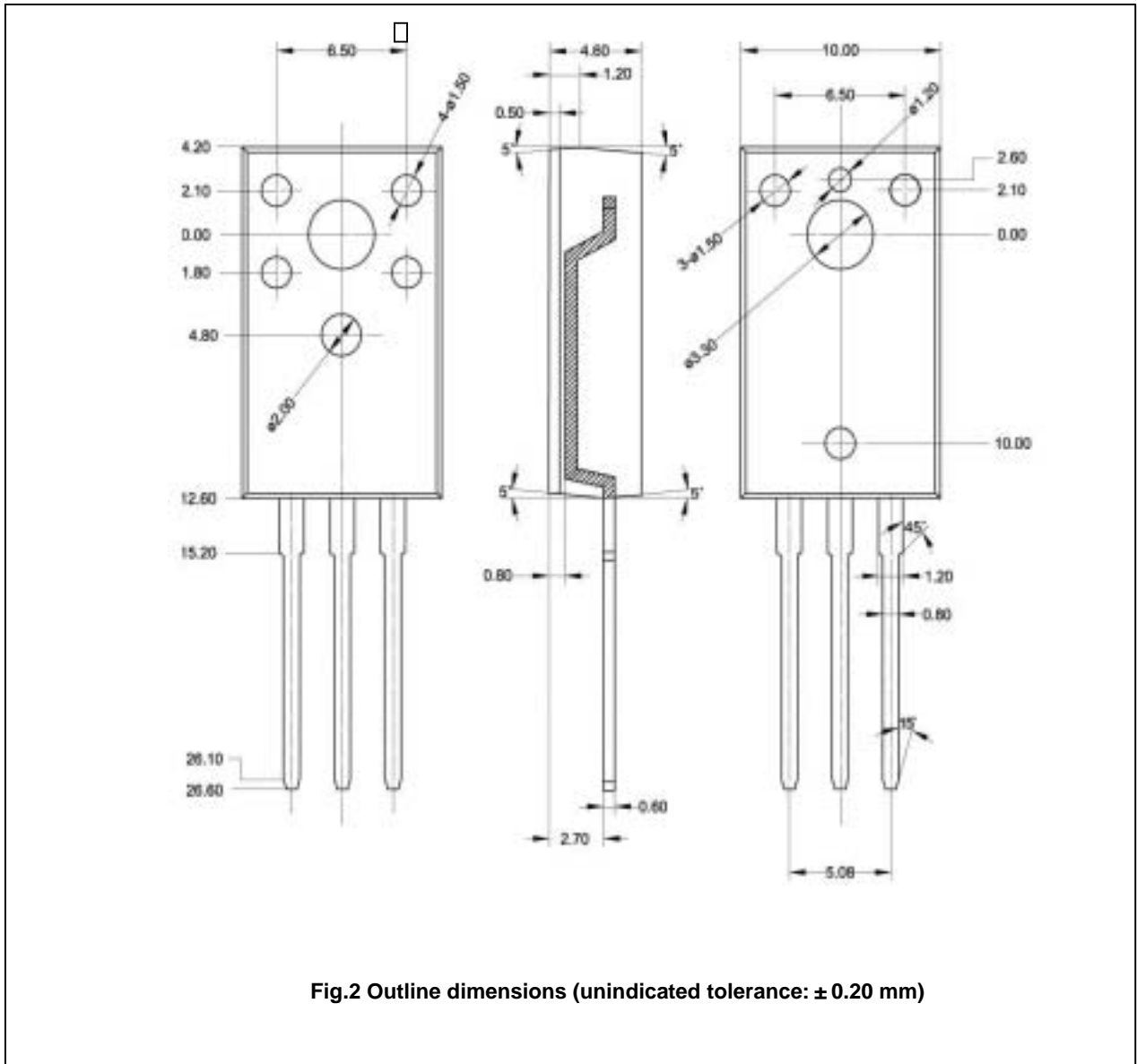

Fig.2 Outline dimensions (unindicated tolerance: ± 0.20 mm)