

**Silicon NPN Power Transistors**

**2SC2209**

**DESCRIPTION**

- With TO-126 package
- Complement to type 2SA963
- High collector power dissipation

**APPLICATIONS**

- For low-frequency power amplification

**PINNING**

PIN	DESCRIPTION
1	Emitter
2	Collector;connected to mounting base
3	Base

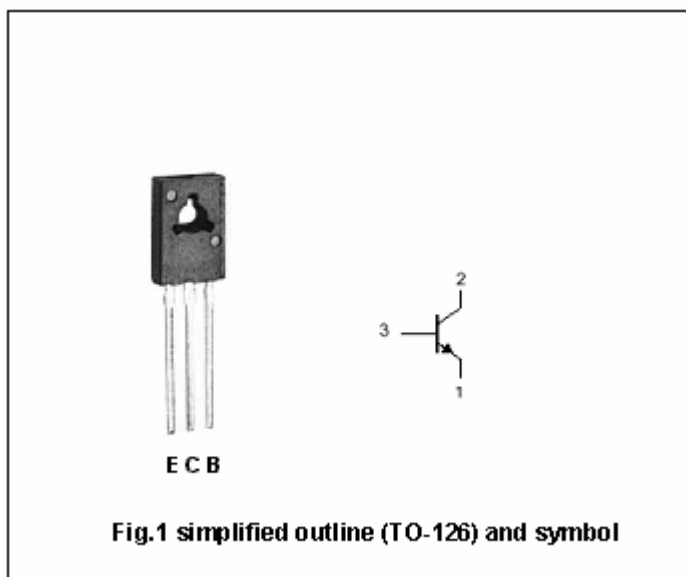

**Absolute Maximum Ratings (Ta=25°C)**

SYMBOL	PARAMETER	CONDITIONS	VALUE	UNIT
V <sub>CBO</sub>	Collector-base voltage	Open emitter	50	V
V <sub>CEO</sub>	Collector-emitter voltage	Open base	40	V
V <sub>EBO</sub>	Emitter-base voltage	Open collector	5	V
I <sub>C</sub>	Collector current (DC)		1.5	A
I <sub>CM</sub>	Collector current-peak		3	A
P <sub>C</sub>	Collector power dissipation	T <sub>C</sub> =25°C	10	W
T <sub>j</sub>	Junction temperature		150	°C
T <sub>stg</sub>	Storage temperature		-55~150	°C

## Silicon NPN Power Transistors

## 2SC2209

## CHARACTERISTICS

T<sub>j</sub>=25°C unless otherwise specified

SYMBOL	PARAMETER	CONDITIONS	MIN	TYP.	MAX	UNIT
V <sub>(BR)CEO</sub>	Collector-emitter breakdown voltage	I <sub>C</sub> =2mA; I <sub>B</sub> =0	40			V
V <sub>(BR)CBO</sub>	Collector-base breakdown voltage	I <sub>C</sub> =1mA; I <sub>E</sub> =0	50			V
V <sub>CEsat</sub>	Collector-emitter saturation voltage	I <sub>C</sub> =1.5A; I <sub>B</sub> =150mA			1.0	V
V <sub>BEsat</sub>	Base-emitter saturation voltage	I <sub>C</sub> =2A; I <sub>B</sub> =0.2A			1.5	V
I <sub>CBO</sub>	Collector cut-off current	V <sub>CB</sub> =20V; I <sub>E</sub> =0			1	μA
I <sub>CEO</sub>	Collector cut-off current	V <sub>CE</sub> =10V; I <sub>B</sub> =0			100	μA
I <sub>EBO</sub>	Emitter cut-off current	V <sub>EB</sub> =5V; I <sub>C</sub> =0			10	μA
h <sub>FE</sub>	DC current gain	I <sub>C</sub> =1A; V <sub>CE</sub> =5V	80		220	
C <sub>OB</sub>	Output capacitance	I <sub>E</sub> =0; V <sub>CB</sub> =5V; f=1MHz		50		pF
f <sub>T</sub>	Transition frequency	I <sub>C</sub> =0.5A; V <sub>CB</sub> =5V; f=200MHz		150		MHz

◆ h<sub>FE</sub> Classifications

Q	R
80-160	120-220

PACKAGE OUTLINE

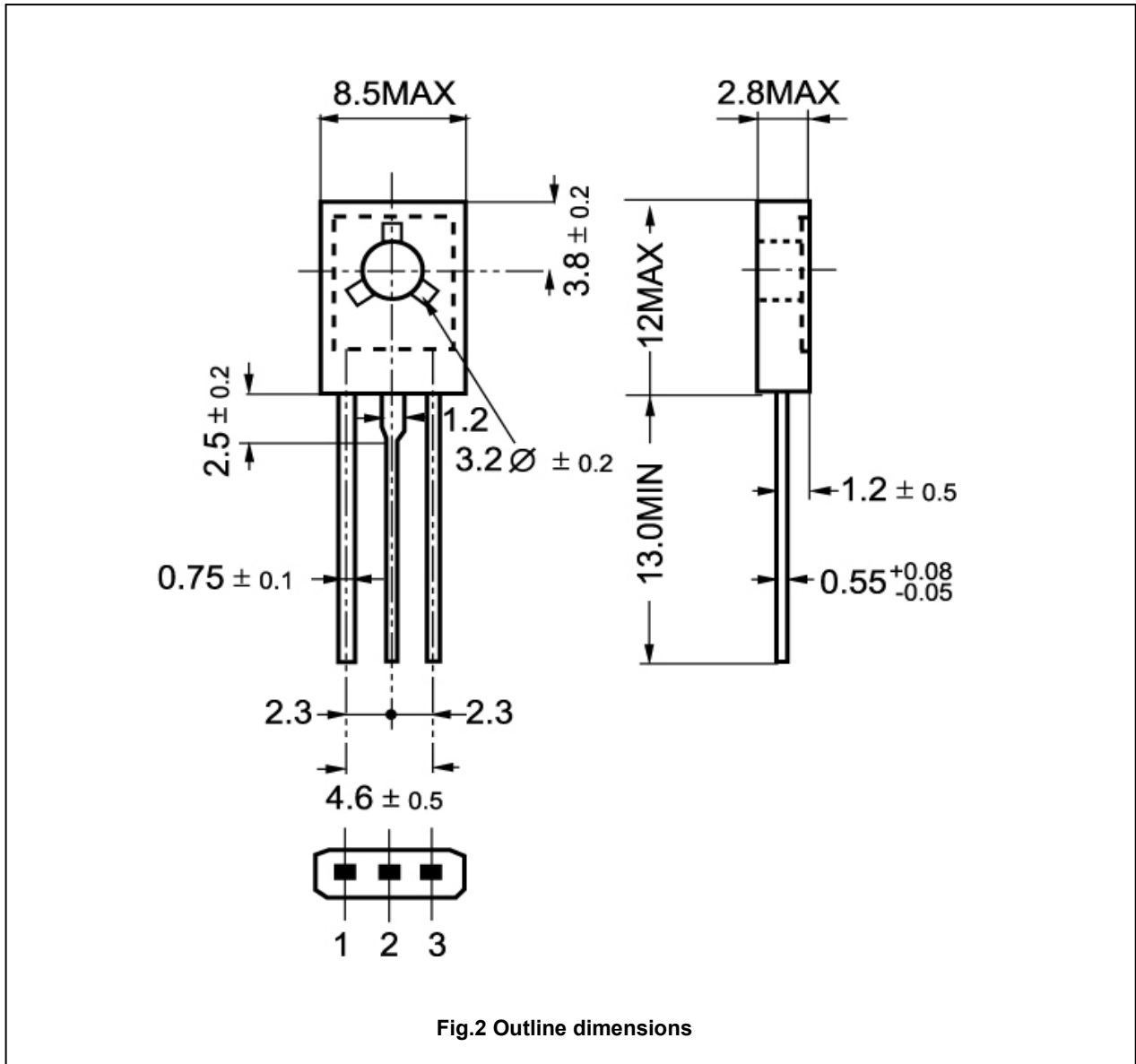

Silicon NPN Power Transistors

2SC2209

