



Shanghai Lunsure Electronic
Technology Co.,Ltd
Tel:0086-21-37185008
Fax:0086-21-57152769

BAT45

30Milliamp Small Signal Schottky Diode 15 Volt

Features

- Metal-to-silicon junction
- Low turn-on voltage
- Ultrafast switching speed

Maximum Ratings

- Operating Temperature: -55°C to +125°C
- Storage Temperature: 55°C to +150°C
- Maximum Thermal Resistance; 400°C/W Junction To Ambient

Electrical Characteristics @ 25°C Unless Otherwise Specified

Peak Reverse Voltage	V_{RM}	15V	
Forward continuous Current	I_F	30mA	$T_A = 25^\circ C$
Junction Temperature	T_J	125°C	
Peak Forward Surge Current	I_{FSM}	60mA	$T_p \leq 1s,$ $T_A = 25^\circ C$
Maximum Instantaneous Forward Voltage	V_F	0.38V 0.50V 1.0V	$I_F = 1mA$ $I_F = 10mA$ $I_F = 30mA$
Maximum DC Reverse Current At Rated DC Blocking Voltage	I_R	100nA	$V_R = 6.0Volts$ $T_J = 25^\circ C$
Reverse Breakover Voltage	V_R	15V	$I_R = 10\mu A$
Typical Junction Capacitance	C_J	1.1pF	Measured at 1.0MHz, $V_R = 1V$

Pulse Test: 300µSec pulse width, 2% duty cycle

DO-35

DIMENSIONS					
DIM	INCHES		MM		NOTE
	MIN	MAX	MIN	MAX	
A	---	.166	---	4.2	
B	---	.079	---	2.00	
C	---	.020	---	.52	
D	1.000	---	25.40	---	

BAT45

Figure 1. Forward current versus forward voltage at different temperatures (typical values)

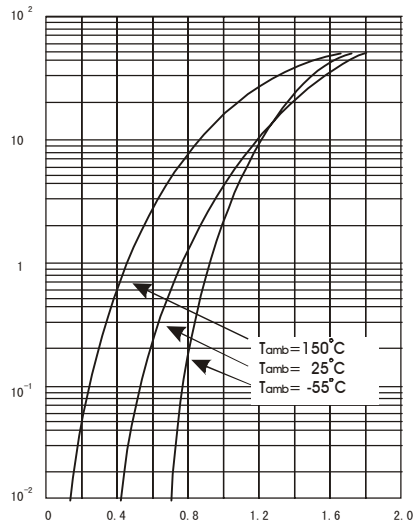

Figure 2. Forward current versus forward voltage (typical values)

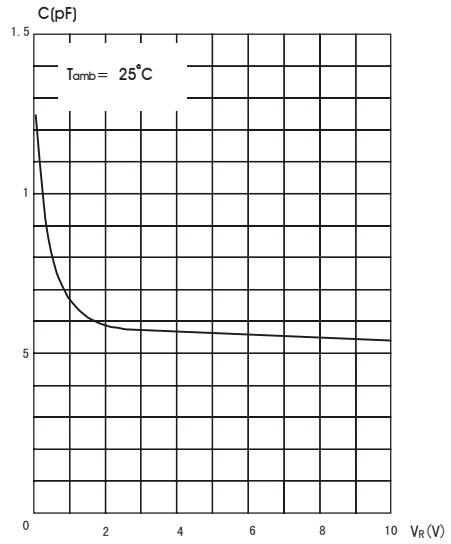

Figure 3. Reverse current versus ambient temperature

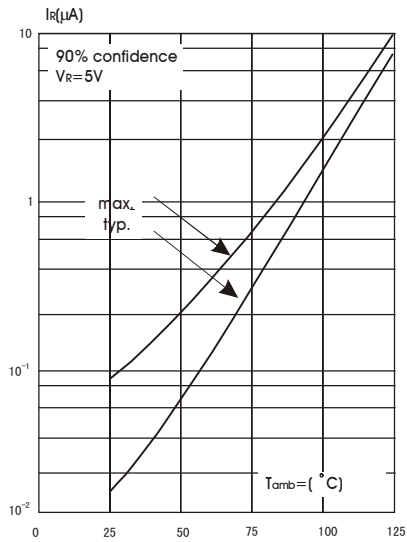

Figure 4. Reverse current versus continuous reverse voltage (typical values)

