

Document Title

64K x16 bit Super Low Power and Low Voltage Full CMOS Static RAM

Revision History

Revision No.	History	Draft Date	Remark
0.0	Initial Draft	May 9 , 2003	
0.1	2' nd Draft    Add Pb-free part number	February 13 , 2004	

**Emerging Memory & Logic Solutions Inc.**

IT Venture Tower Eastside 11F, 78, Karac-Dong, Songpa-Ku, Seoul, Rep.of Korea    Zip Code : 138-160  
Tel : +82-2-2142-1759~1766    Fax : +82-2-2142-1769 /    Homepage : www.emlsi.com

---

The attached datasheets are provided by EMLSI reserve the right to change the specifications and products. EMLSI will answer to your questions about device. If you have any questions, please contact the EMLSI office.

**FEATURES**

- Process Technology : 0.18µm Full CMOS
- Organization : 64K x 16 bit
- Power Supply Voltage : 2.7V ~ 3.6V
- Low Data Retention Voltage : 1.5V(Min.)
- Three state output and TTL Compatible
- Package Type : 44-TSOP2

**GENERAL DESCRIPTION**

The EM611FV16U families are fabricated by EMLSI' s advanced full CMOS process technology. The families support industrial temperature range and Chip Scale Package for user flexibility of system design. The families also supports low data retention voltage for battery back-up operation with low data retention current.

**PRODUCT FAMILY**

Product Family	Operating Temperature	Vcc Range	Speed	Power Dissipation		PKG Type
				Standby (I <sub>SB1</sub> , Typ.)	Operating (I <sub>CC1</sub> .Max.)	
EM611FV16U	Industrial (-40 ~ 85°C)	2.7V~3.6V	55 <sup>1)</sup> /70ns	0.5 µA <sup>2)</sup>	3 mA	44 TSOP2

1. The parameter is measured with 30pF test load.  
2. Typical values are measured at Vcc=3.3V, T<sub>A</sub>=25°C and not 100% tested.

**PIN DESCRIPTION**

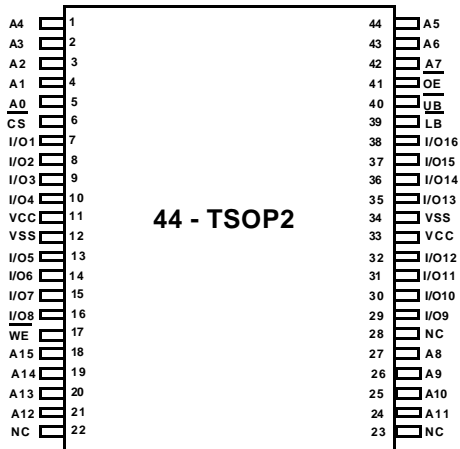

Name	Function	Name	Function
$\overline{CS}$	Chip select input	Vcc	Power Supply
$\overline{OE}$	Output Enable input	Vss	Ground
$\overline{WE}$	Write Enable input	$\overline{UB}$	Upper Byte (I/O <sub>9-16</sub> )
A <sub>0</sub> -A <sub>15</sub>	Address Inputs	$\overline{LB}$	Lower Byte (I/O <sub>1-8</sub> )
I/O <sub>1</sub> -I/O <sub>16</sub>	Data Inputs/outputs	NC	No Connection

**FUNCTIONAL BLOCK DIAGRAM**

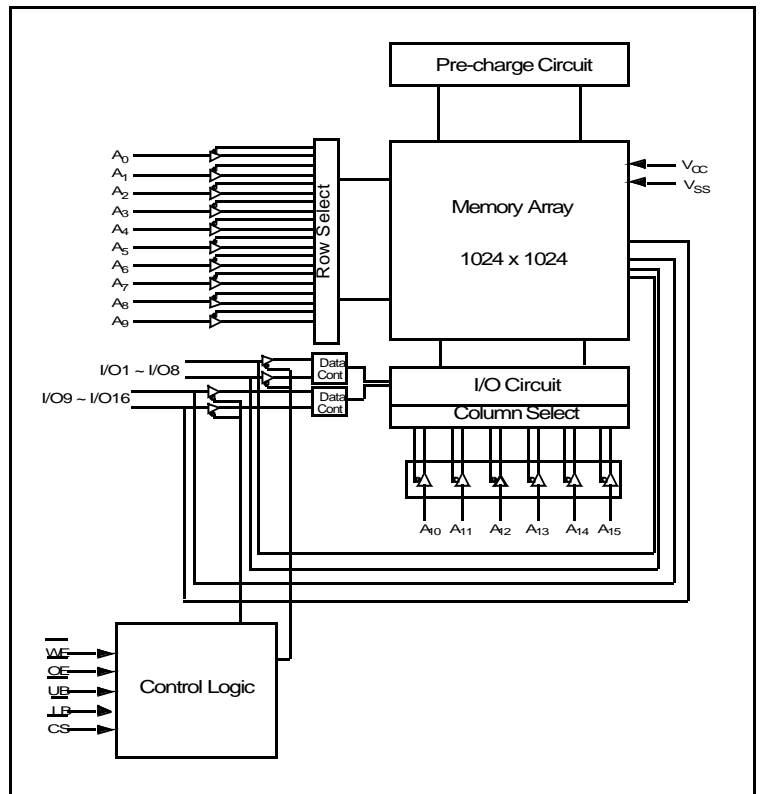

**ABSOLUTE MAXIMUM RATINGS \***

Parameter	Symbol	Ratings	Unit
Voltage on Any Pin Relative to Vss	$V_{IN}, V_{OUT}$	-0.2 to $V_{CC}+0.3$ (Max. 4.0V)	V
Voltage on Vcc supply relative to Vss	$V_{CC}$	-0.2 to 4.0V	V
Power Dissipation	$P_D$	1.0	W
Operating Temperature	$T_A$	-40 to 85	°C

\* Stresses greater than those listed under “Absolute Maximum Ratings” may cause permanent damage to the device. Functional operation should be restricted to recommended operating condition. Exposure to absolute maximum rating conditions for extended periods may affect reliability.

**FUNCTIONAL DESCRIPTION**

$\overline{CS}$	$\overline{OE}$	$\overline{WE}$	$\overline{LB}$	$\overline{UB}$	I/O <sub>1-8</sub>	I/O <sub>9-16</sub>	Mode	Power
H	X	X	X	X	High-Z	High-Z	Deselected	Stand by
L	H	H	X	X	High-Z	High-Z	Output Disabled	Active
L	X	X	H	H	High-Z	High-Z	Output Disabled	Active
L	L	H	L	H	Data Out	High-Z	Lower Byte Read	Active
L	L	H	H	L	High-Z	Data Out	Upper Byte Read	Active
L	L	H	L	L	Data Out	Data Out	Word Read	Active
L	X	L	L	H	Data In	High-Z	Lower Byte Write	Active
L	X	L	H	L	High-Z	Data In	Upper Byte Write	Active
L	X	L	L	L	Data In	Data In	Word Write	Active

Note: X means don't care. (Must be low or high state)

**RECOMMENDED DC OPERATING CONDITIONS** <sup>1)</sup>

Parameter	Symbol	Min	Typ	Max	Unit
Supply voltage	$V_{CC}$	2.7	3.3	3.6	V
Ground	$V_{SS}$	0	0	0	V
Input high voltage	$V_{IH}$	2.2	-	$V_{CC} + 0.2$ <sup>2)</sup>	V
Input low voltage	$V_{IL}$	-0.2 <sup>3)</sup>	-	0.6	V

1.  $T_A = -40$  to  $85^\circ\text{C}$ , otherwise specified
2. Overshoot:  $V_{CC} + 2.0$  V in case of pulse width  $\leq 20$ ns
3. Undershoot:  $-2.0$  V in case of pulse width  $\leq 20$ ns
4. Overshoot and undershoot are sampled, not 100% tested.

**CAPACITANCE** <sup>1)</sup> ( $f = 1\text{MHz}$ ,  $T_A = 25^\circ\text{C}$ )

Item	Symbol	Test Condition	Min	Max	Unit
Input capacitance	$C_{IN}$	$V_{IN} = 0\text{V}$	-	8	pF
Input/Output capacitance	$C_{IO}$	$V_{IO} = 0\text{V}$	-	10	pF

1. Capacitance is sampled, not 100% tested

**DC AND OPERATING CHARACTERISTICS**

Parameter	Symbol	Test Conditions	Min	Typ	Max	Unit
Input leakage current	$I_{LI}$	$V_{IN} = V_{SS}$ to $V_{CC}$	-1	-	1	$\mu\text{A}$
Output leakage current	$I_{LO}$	$\overline{CS} = V_{IH}$ or $\overline{OE} = V_{IH}$ or $\overline{WE} = V_{IL}$ , $V_{IO} = V_{SS}$ to $V_{CC}$	-1	-	1	$\mu\text{A}$
Operating power supply	$I_{CC}$	$I_{IO} = 0\text{mA}$ , $\overline{CS} = V_{IL}$ , $V_{IN} = V_{IH}$ or $V_{IL}$	-	-	3	mA
Average operating current	$I_{CC1}$	Cycle time = $1\mu\text{s}$ , 100% duty, $I_{IO} = 0\text{mA}$ , $\overline{CS} \leq 0.2\text{V}$ , $V_{IN} \leq 0.2\text{V}$ or $V_{IN} \geq V_{CC} - 0.2\text{V}$	-	-	3	mA
	$I_{CC2}$	Cycle time = Min, $I_{IO} = 0\text{mA}$ , 100% duty, $\overline{CS} = V_{IL}$ , $V_{IN} = V_{IL}$ or $V_{IH}$	55ns 70ns	- -	26 20	mA
Output low voltage	$V_{OL}$	$I_{OL} = 2.1\text{mA}$	-	-	0.4	V
Output high voltage	$V_{OH}$	$I_{OH} = -1.0\text{mA}$	2.4	-	-	V
Standby Current (TTL)	$I_{SB}$	$\overline{CS} = V_{IH}$ , Other inputs = $V_{IH}$ or $V_{IL}$	-	-	0.3	mA
Standby Current (CMOS)	$I_{SB1}$	$\overline{CS} \geq V_{CC} - 0.2\text{V}$ Other inputs = $0 \sim V_{CC}$ (Typ. condition : $V_{CC} = 3.3\text{V}$ @ $25^\circ\text{C}$ ) (Max. condition : $V_{CC} = 3.6\text{V}$ @ $85^\circ\text{C}$ )	LL LF	-	0.5 <sup>1)</sup>	5 $\mu\text{A}$

**NOTES**

1. Typical values are measured at  $V_{CC} = 3.3\text{V}$ ,  $T_A = 25^\circ\text{C}$  and not 100% tested.

**AC OPERATING CONDITIONS**
**Test Conditions** (Test Load and Test Input/Output Reference)

 Input Pulse Level : 0.4 to 2.2V  
 Input Rise and Fall Time : 5ns  
 Input and Output reference Voltage : 1.5V  
 Output Load (See right) : CL = 100pF + 1 TTL

$$CL^{(1)} = 30\text{pF} + 1 \text{ TTL}$$

1. Including scope and Jig capacitance

 2.  $R_1=3070\Omega$ ,  $R_2=3150\Omega$ 

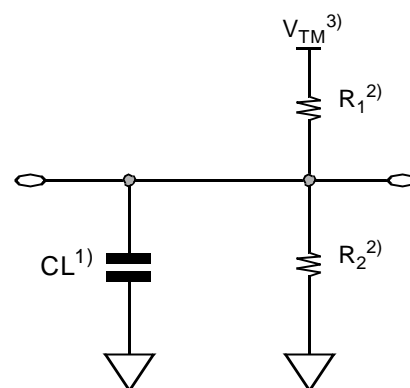
 3.  $V_{TM}=2.8\text{V}$ 

**READ CYCLE** ( $V_{CC} = 2.7$  to  $3.6\text{V}$ ,  $Gnd = 0\text{V}$ ,  $T_A = -40^\circ\text{C}$  to  $+85^\circ\text{C}$ )

Parameter	Symbol	55ns		70ns		Unit
		Min	Max	Min	Max	
Read cycle time	$t_{RC}$	55	-	70	-	ns
Address access time	$t_{AA}$	-	55	-	70	ns
Chip select to output	$t_{CO}$	-	55	-	70	ns
Output enable to valid output	$t_{OE}$	-	25	-	35	ns
$\overline{UB}$ , $\overline{LB}$ access time	$t_{BA}$		30		35	ns
Chip select to low-Z output	$t_{LZ}$	10	-	10	-	ns
$\overline{UB}$ , $\overline{LB}$ enable to low-Z output	$t_{BLZ}$	5	-	5	-	ns
Output enable to low-Z output	$t_{OLZ}$	5	-	5	-	ns
Chip disable to high-Z output	$t_{HZ}$	0	20	0	25	ns
$\overline{UB}$ , $\overline{LB}$ disable to high-Z output	$t_{BHZ}$	0	20	0	25	ns
Output disable to high-Z output	$t_{OHZ}$	0	20	0	25	ns
Output hold from address change	$t_{OH}$	10	-	10	-	ns

**WRITE CYCLE** ( $V_{CC} = 2.7$  to  $3.6\text{V}$ ,  $Gnd = 0\text{V}$ ,  $T_A = -40^\circ\text{C}$  to  $+85^\circ\text{C}$ )

Parameter	Symbol	55ns		70ns		Unit
		Min	Max	Min	Max	
Write cycle time	$t_{WC}$	55	-	70	-	ns
Chip select to end of write	$t_{CW}$	45	-	60	-	ns
Address setup time	$t_{As}$	0	-	0	-	ns
Address valid to end of write	$t_{AW}$	45	-	60	-	ns
$\overline{UB}$ , $\overline{LB}$ valid to end of write	$t_{BW}$	45	-	60	-	ns
Write pulse width	$t_{WP}$	40	-	50	-	ns
Write recovery time	$t_{WR}$	0	-	0	-	ns
Write to output high-Z	$t_{WHZ}$	0	25	0	30	ns
Data to write time overlap	$t_{DW}$	25		30		ns
Data hold from write time	$t_{DH}$	0	-	0	-	ns
End write to output low-Z	$t_{OW}$	5	-	5	-	ns

**TIMING DIAGRAMS**

**TIMING WAVEFORM OF READ CYCLE(1).** (Address Controlled,  $\overline{CS}=\overline{OE}=V_{IL}$ ,  $\overline{WE}=V_{IH}$ ,  $\overline{UB}$  or/and  $\overline{LB}=V_{IL}$ )

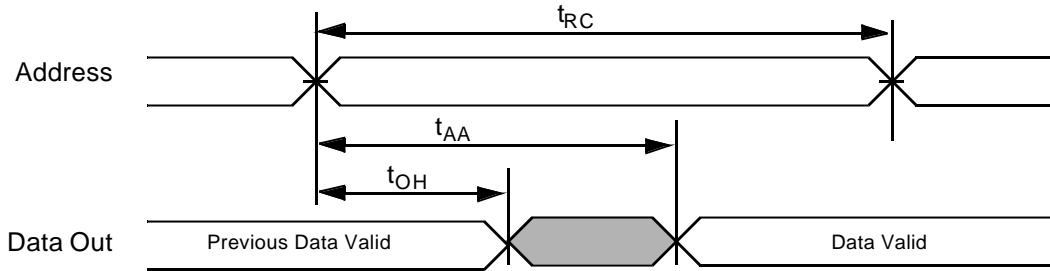

**TIMING WAVEFORM OF READ CYCLE(2)** ( $\overline{WE} = V_{IH}$ )

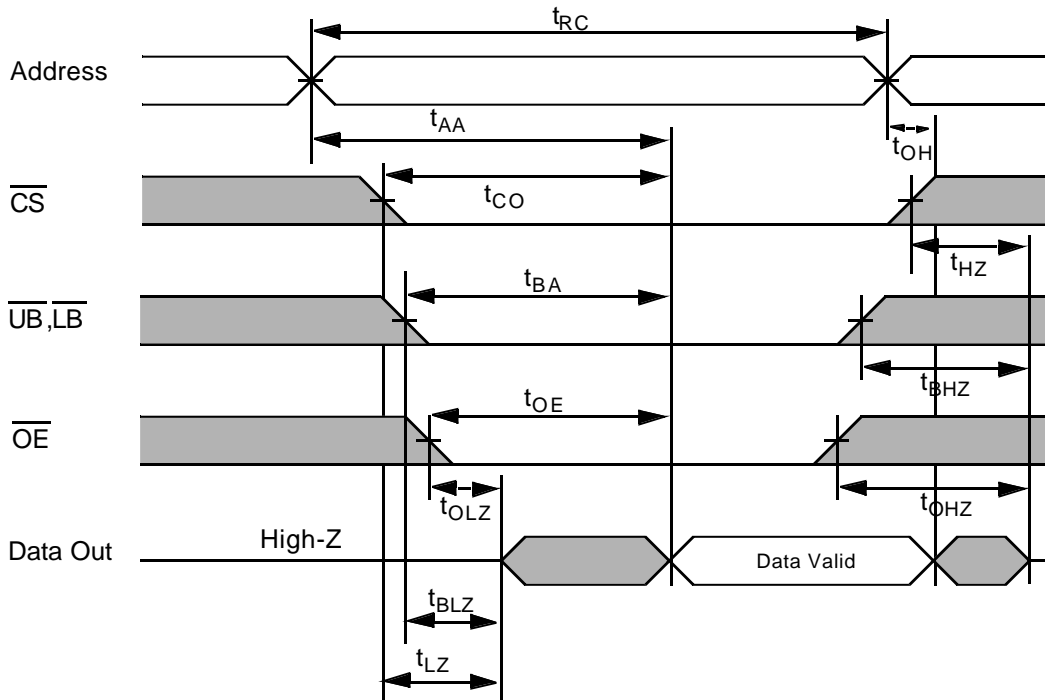

**NOTES (READ CYCLE)**

1.  $t_{HZ}$  and  $t_{OHZ}$  are defined as the outputs achieve the open circuit conditions and are not referenced to output voltage levels.
2. At any given temperature and voltage condition,  $t_{HZ}(\text{Max.})$  is less than  $t_{LZ}(\text{Min.})$  both for a given device and from device to device interconnection.

**TIMING WAVEFORM OF WRITE CYCLE(1) ( $\overline{WE}$  CONTROLLED)**

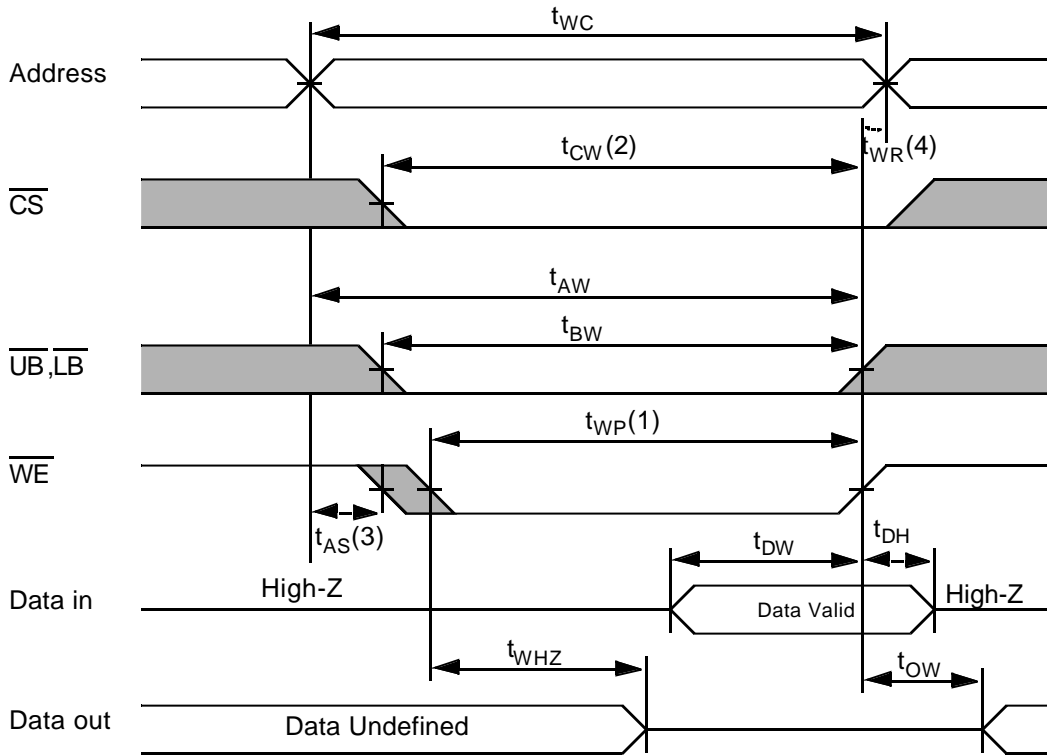

**TIMING WAVEFORM OF WRITE CYCLE(2) ( $\overline{CS}$  CONTROLLED)**

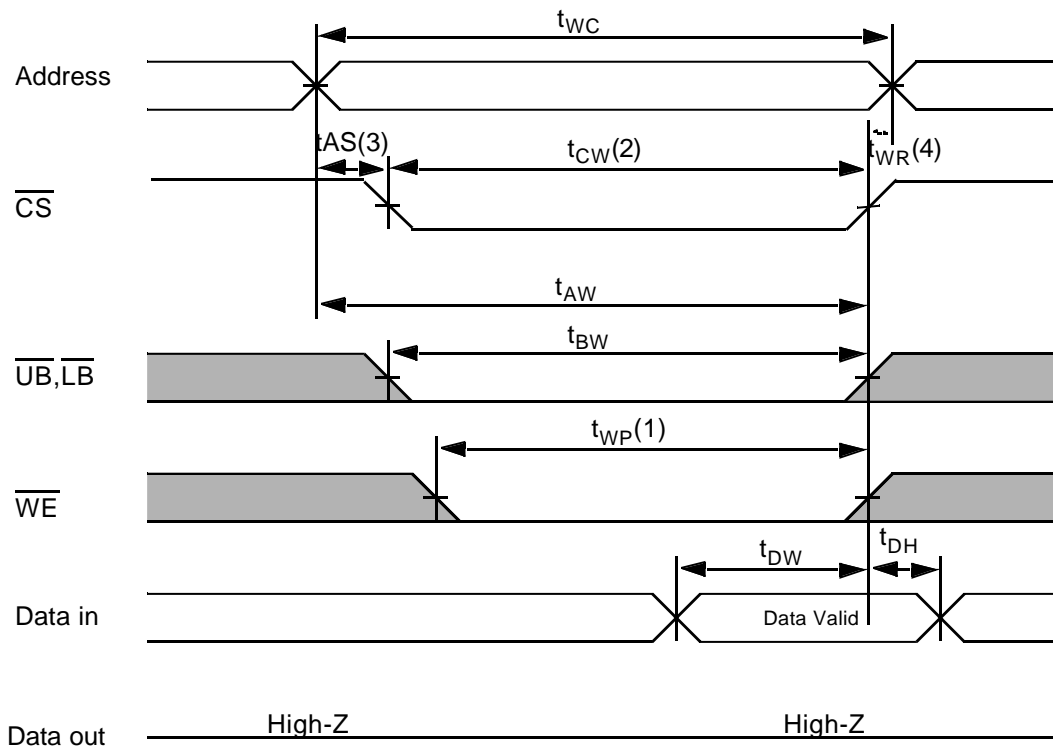

**TIMING WAVEFORM OF WRITE CYCLE(3) ( $\overline{UB}$ ,  $\overline{LB}$  CONTROLLED)**

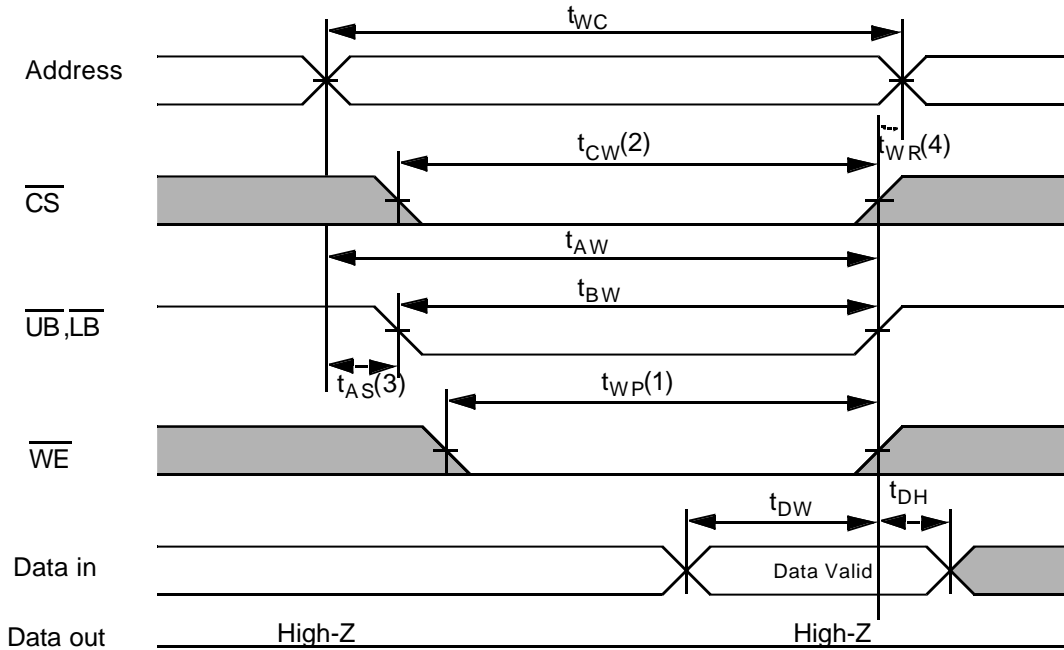

**NOTES (WRITE CYCLE)**

1. A write occurs during the overlap( $t_{WP}$ ) of low  $\overline{CS}$  and low  $\overline{WE}$ . A write begins when  $\overline{CS}$  goes low and  $\overline{WE}$  goes low with asserting  $\overline{UB}$  or  $\overline{LB}$  for single byte operation or simultaneously asserting  $\overline{UB}$  and  $\overline{LB}$  for double byte operation. A write ends at the earliest transition when  $\overline{CS}$  goes high and  $\overline{WE}$  goes high. The  $t_{WP}$  is measured from the beginning of write to the end of write.
2.  $t_{CW}$  is measured from the  $\overline{CS}$  going low to end of write.
3.  $t_{AS}$  is measured from the address valid to the beginning of write.
4.  $t_{WR}$  is measured from the end of write to the address change.  $t_{WR}$  applied in case a write ends as  $\overline{CS}$  or  $\overline{WE}$  going high.



**DATA RETENTION CHARACTERISTICS**

Parameter	Symbol	Test Condition	Min	Typ <sup>2)</sup>	Max	Unit
V <sub>CC</sub> for Data Retention	V <sub>DR</sub>	I <sub>SB1</sub> Test Condition (Chip Disabled) <sup>1)</sup>	1.5	-	3.6	V
Data Retention Current	I <sub>DR</sub>	V <sub>CC</sub> =1.5V, I <sub>SB1</sub> Test Condition (Chip Disabled) <sup>1)</sup>	-	0.25	-	μA
Chip Deselect to Data Retention Time	t <sub>SDR</sub>	See data retention wave form	0	-	-	ns
Operation Recovery Time	t <sub>RDR</sub>		t <sub>RC</sub>	-	-	

**NOTES**

1. See the I<sub>SB1</sub> measurement condition of datasheet page 4.
2. Typical values are measured at T<sub>A</sub>=25°C and not 100% tested.

**DATA RETENTION WAVE FORM**

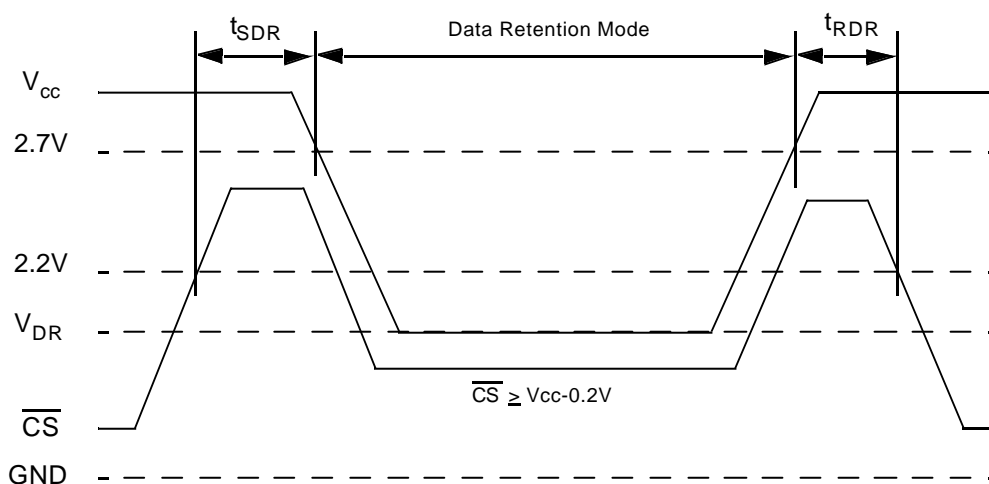

Unit: millimeters

**PACKAGE DIMENSION**

44 PIN THIN SMALL OUTLINE PACKAGE TYPE II (400F)

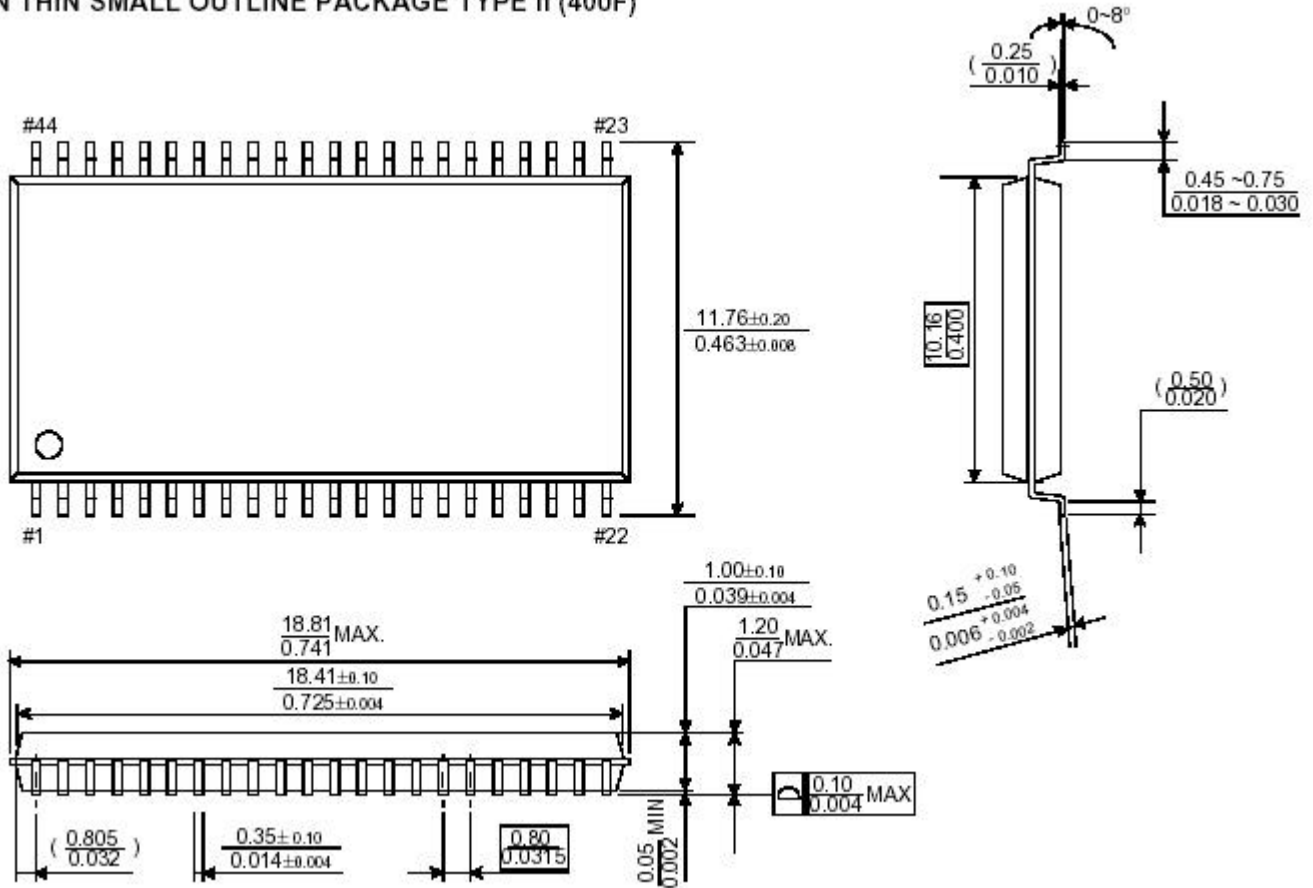

**MEMORY FUNCTION GUIDE**

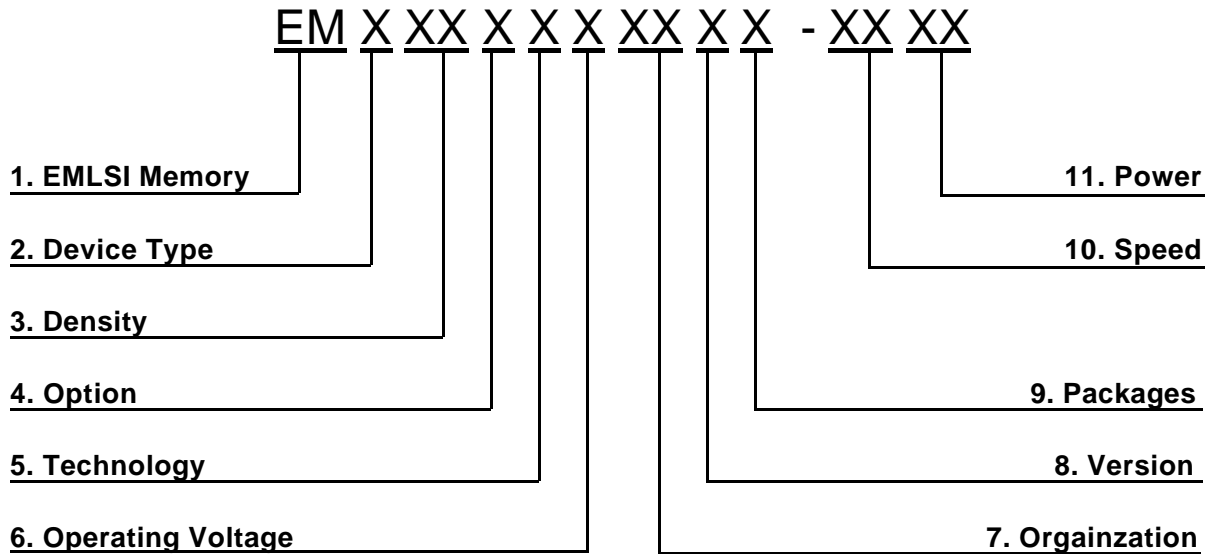

- 1. Memory Component
- 2. Device Type
  - 6 ----- Low Power SRAM
  - 7 ----- STRAM
- 3. Density
  - 1 ----- 1M
  - 2 ----- 2M
  - 4 ----- 4M
  - 8 ----- 8M
  - 16 ----- 16M
  - 32 ----- 32M
  - 64 ----- 64M
- 4. Option
  - 0 ----- Dual CS
  - 1 ----- Single CS
- 5. Technology
  - Blank ----- CMOS
  - F ----- Full CMOS
- 6. Operating Voltage
  - Blank ----- 5.0V
  - V ----- 2.7V~3.6V
  - U ----- 3.0V
  - S ----- 2.5V
  - R ----- 2.0V
  - P ----- 1.8V
- 7. Organization
  - 8 ----- x8 bit
  - 16 ----- x16 bit
  - 32 ----- x32 bit

- 8. Version
  - Blank ----- Mother Die
  - A ----- First revision
  - B ----- Second revision
  - C ----- Third revision
  - D ----- Fourth revision
  - E ----- Fifth revision
  - F ----- Sixth revision
- 9. Package
  - Blank ----- FPBGA
  - S ----- 32 sTSOP1
  - T ----- 32 TSOP1
  - U ----- 44 TSOP2
  - W ----- Wafer
- 10. Speed
  - 45 ----- 45ns
  - 55 ----- 55ns
  - 70 ----- 70ns
  - 85 ----- 85ns
  - 10 ----- 100ns
  - 12 ----- 120ns
- 11. Power
  - LL ----- Low Low Power
  - LF ----- Low Low Power(Pb-Free)
  - L ----- Low Power
  - S ----- Standard Power