

# AS1542

Product Brief

## 16-Channel, 1 Msps, 12-Bit ADC with Sequencer

### 1 General Description

The AS1542 is a 12-bit high-speed, low-power, 16-channel, successive-approximation ADC that operates from a single 2.7 to 5.25V supply. The device features high throughput rates (1Msps) and a low-noise, wide-bandwidth track-and-hold amplifier that can handle input frequencies in excess of 1 MHz.

The AS1542 features 16 single-ended or 8 fully differential analog inputs with a channel sequencer to allow a programmed selection of channels to be converted sequentially. The conversion time is determined by the SCLK frequency (also used as the master clock to control the conversion).

The conversion process and data acquisition are controlled using a chip select pin and a serial clock signal, allowing the device to easily interface with microprocessors or DSPs. The input signal is sampled on the falling edge of CSN and conversion is also initiated at this point. There are no pipeline delays associated with the device.

The AS1542 uses advanced design techniques to achieve very low power dissipation at high throughput rates. At maximum throughput rates, the AS1542 consumes just 2.8mA (@3.6V), and 3.5mA (@5.25V).

By using internal control register, single-ended or fully-differential conversion mode with different input ranges can be used with either straight binary or twos complement output coding.

The device is available in a TSSOP-28 pin package.

### 2 Key Features

- Single Supply Operation with VDRIVE Function: 2.7 to 5.25V
- Fast Throughput Rate: 1 Msps
- Sequencer & Channel Counter
- Software-Configurable Analog Input Types:
  - 16-Channel Single-Ended
  - 8-Channel Fully-Differential
- Software-Configurable Input Range
- Low Power Consumption at Max Throughput Rates:
  - 10.1mW @ 1Msps (3.6V Supply)
  - 18.4mW @ 1Msps (5.25V Supply)
- Shutdown Mode Current: 0.5µA
- Flexible Power/Serial Clock Speed Management
- Wide Input Bandwidth: 71dB SNR @ 50 kHz Input Frequency
- No Pipeline Delays
- High Speed SPI/QSPI/Microwire/DSP Interface
- TSSOP-28 Package

### 3 Applications

The devices are ideal for remote sensors, data-acquisition and data-logging devices, pen-digitizers, process control, or any other space-limited A/D application with low power-consumption requirements.

Figure 1. Typical Application

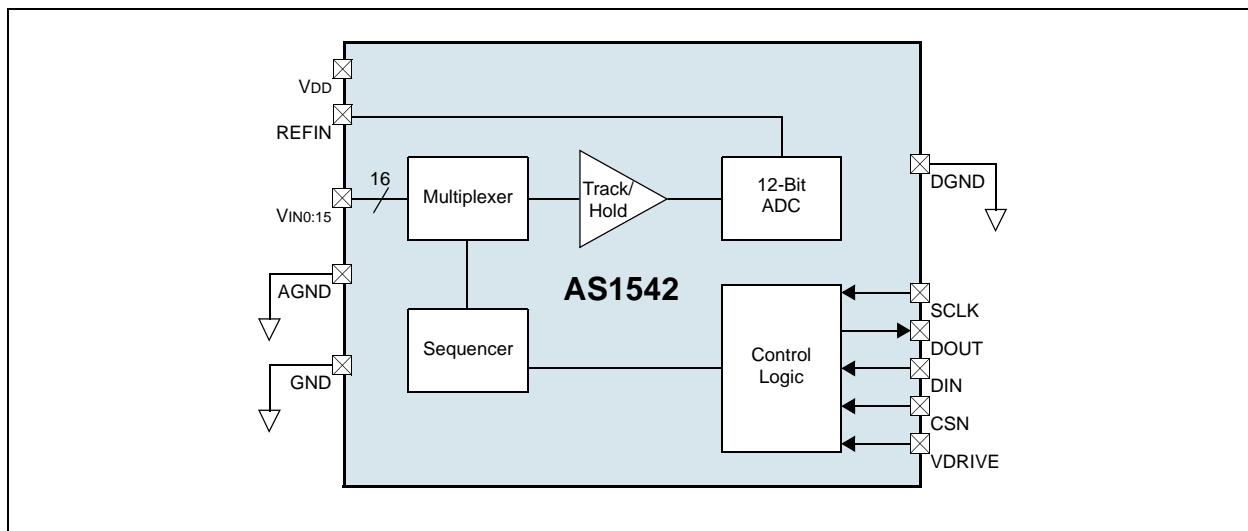

## Copyrights

Copyright © 1997-2007, austriamicrosystems AG, Schloss Premstaetten, 8141 Unterpremstaetten, Austria-Europe. Trademarks Registered ®. All rights reserved. The material herein may not be reproduced, adapted, merged, translated, stored, or used without the prior written consent of the copyright owner.

All products and companies mentioned are trademarks or registered trademarks of their respective companies.

## Disclaimer

Devices sold by austriamicrosystems AG are covered by the warranty and patent indemnification provisions appearing in its Term of Sale. austriamicrosystems AG makes no warranty, express, statutory, implied, or by description regarding the information set forth herein or regarding the freedom of the described devices from patent infringement. austriamicrosystems AG reserves the right to change specifications and prices at any time and without notice. Therefore, prior to designing this product into a system, it is necessary to check with austriamicrosystems AG for current information. This product is intended for use in normal commercial applications. Applications requiring extended temperature range, unusual environmental requirements, or high reliability applications, such as military, medical life-support or life-sustaining equipment are specifically not recommended without additional processing by austriamicrosystems AG for each application. For shipments of less than 100 parts the manufacturing flow might show deviations from the standard production flow, such as test flow or test location.

The information furnished here by austriamicrosystems AG is believed to be correct and accurate. However, austriamicrosystems AG shall not be liable to recipient or any third party for any damages, including but not limited to personal injury, property damage, loss of profits, loss of use, interruption of business or indirect, special, incidental or consequential damages, of any kind, in connection with or arising out of the furnishing, performance or use of the technical data herein. No obligation or liability to recipient or any third party shall arise or flow out of austriamicrosystems AG rendering of technical or other services.



## Contact Information

### Headquarters

austriamicrosystems AG  
A-8141 Schloss Premstaetten, Austria

Tel: +43 (0) 3136 500 0  
Fax: +43 (0) 3136 525 01

For Sales Offices, Distributors and Representatives, please visit:

<http://www.austriamicrosystems.com/contact>