

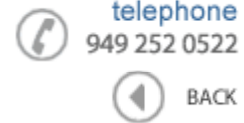

Data Sheet



Product Category: SMD Quartz Crystal

Series Number	Package	Description	Last Modified
224	Ultra Slim	32.768 KHz Crystal	Jan. 02 2005

## FEATURES

- Ultra slim package
- Low profile
- Tape & Reel
- Long term stability
- Industry standard footprint
- Excellent shock resistance
- Excellent environmental characteristics
- RoHs / Lead Free compliant



## OPERATING CONDITIONS / ELECTRICAL CHARACTERISTICS

PARAMETERS		CHARACTERISTICS	UNITS
Nominal Frequency	$f_O$	32.768 (typ.)	KHz
Turnover Temperature	$T_O$	+25 $\pm$ 5	$^{\circ}$ C
Operating Temperature	$T_{OPR}$	-40 ~ +85	$^{\circ}$ C
Storage Temperature	$T_{STG}$	-55 ~ +125	$^{\circ}$ C
Equivalent Series Resistance	$R_1$	65 max.	Kohm
Load Capacitance	$C_L$	12.5 (typ.) / 7.0 (Optional)	pF
Motional Capacitance	$C_1$	1.9 (typ.)	fF
Shunt Capacitance	$C_0$	0.8 (typ.)	pF
Temperature Coefficient	K	-0.000000040 / $^{\circ}$ C <sup>2</sup> max.	-
Drive Level	$D_L$	1 max.	$\mu$ W
Insulation Resistance	IR	500 min. DC 100V	Mohm
Aging (First Year)	$\Delta f/fo$	$\pm$ 3 PPM max. @25 $^{\circ}$ C	PPM
Frequency Tolerance	@25 $^{\circ}$ C	$\pm$ 20	PPM
Q Factor	Q	40,000 min.	-

**PACKAGE DIMENSIONS (mm)**

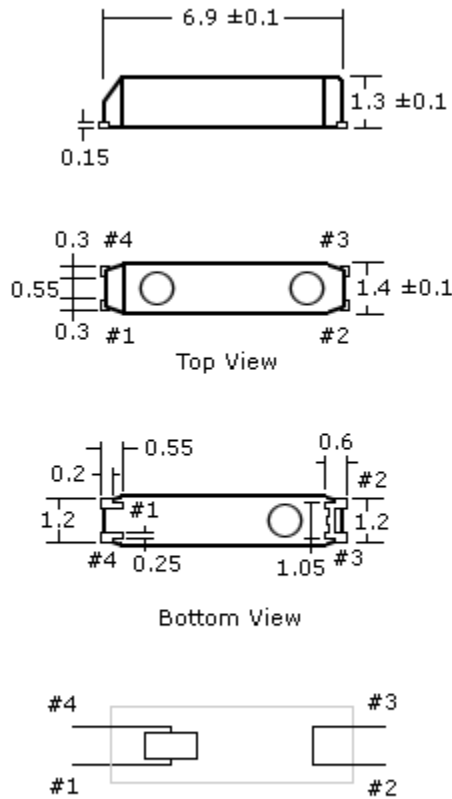

Figure 1) Pin Connection

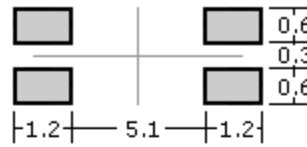
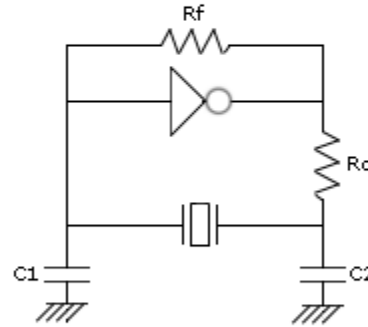

Figure 2) Land Pattern - Top View

**RECOMMENDED OSCILLATION CIRCUIT**



**ELECTRICAL CHARACTERISTICS**

IC: 74HCU04AP  
 Rf: 10 Megohms  
 Rd: 330 Kohms  
 C1 = 14pF  
 C2 = 14pF  
 Vdd = 3.0V

**PART NUMBER GUIDE**

Size	Figure No.	Frequency	Load Capacitance	Part Number	Packaging**
SMD	1, & 2	32.768	12.5	<b>224-000312-20</b>	Blank* = Bulk -TR = Tape/ Reel
			7.0	<b>224-000307-20</b>	

**NOTE:** - Deviations on all parameters available. Please consult Oscilent for details.

**DEFINITIONS:** - Click on the characteristic names above, for definitions of the particular characteristic.

**\*STANDARDS:** - "Blank" part number selections, indicate standard variables for the particular characteristic.

**\*\*PACKAGING:** - Click on the packaging name above for tape/reel specifications

**Oscilent Corporation** - CALL **949.252.0522**

**Series No.:** **224**

18195 East McDermott Street , Building D , Irvine , CA 92614 , USA  
 Fax: 949.252.0599 , E-Mail: Sales@Oscilent.com