

10/100Base-TX Interface Module with Enhanced Common Mode Attenuation

EPF8143SE & EPF8143SE-RC



- Recommended for Enable EL40C331, Broadcom BCM5201, BCM5202 & Level One LXT970 when connected per appropriate schematic
- Designed to operate from -40°C to +85°C @ 8 mA DC Bias
- Complies with or exceeds IEEE 802.3 & ANSI X3.263 Standards
- Add "-RC" after part number for RoHS Compliant
- Peak Solder Rating (see Note 2)

Electrical Parameters @ 25° C

OCL @ 70°C	Insertion Loss (dB Max.)		Return Loss (dB Min.)			Common Mode Rejection (dB Min.)			Crosstalk (dB Min.)
	100 KHz, 0.1 Vrms 8 mA DC Bias	0.1-100 MHz	150 MHz	1-30 MHz	60 MHz	100 MHz	1-30 MHz	30-100 MHz	
	Xmit/Rcv	Xmit/Rcv	Xmit/Rcv	Xmit/Rcv	Xmit/Rcv	Xmit/Rcv	Xmit/Rcv	Xmit/Rcv	Xmit/Rcv
350 µH	-1/-1	-3/-3	-18/-18	-12/-12	-10/-10	-40/-40	-35/-30	-10/-10	-35

• Isolation : 1500 Vrms • Impedance : 100 • Rise Time : 3.0 nS Max. •

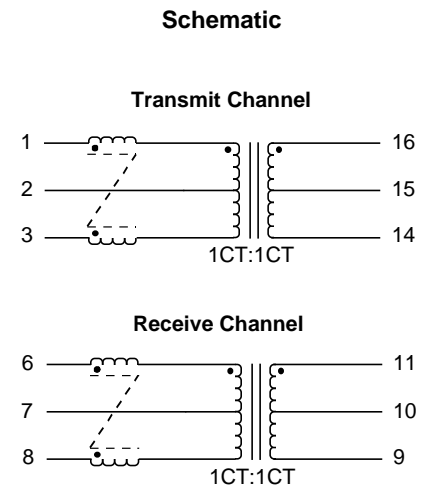
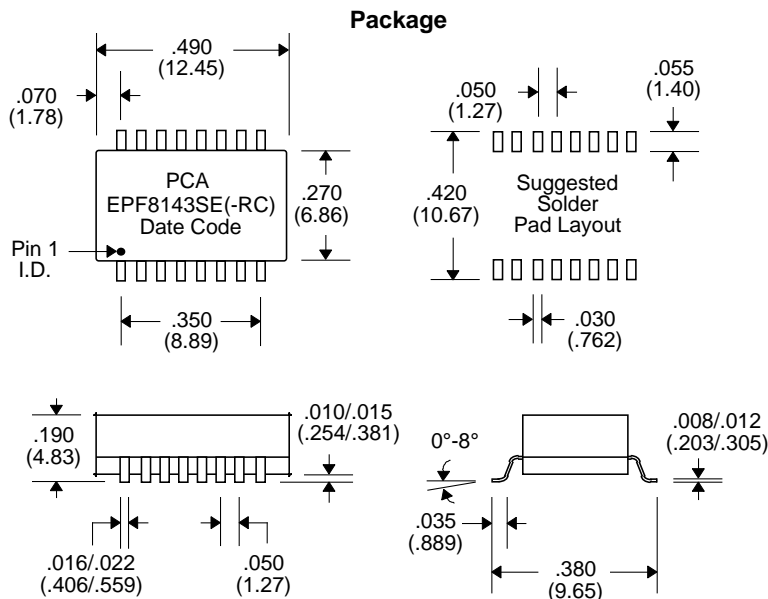

Notes :	EPF8143SE	EPF8143SE-RC
1. Lead Finish	SnPb	Hot Dipped Sn or SAC
2. Peak Temperature Rating	225°C	260°C
3. Moisture Sensitive Levels	MSL = 3 (168 Hours, 30°C/60%RH)	MSL = 4 (72 Hours, 30°C/60%RH)
4. Weight	0.912 grams	0.912 grams
5. Packaging Information	(Tube) 40 pieces/tube	40 pieces/tube
	(Tape & Reel) 650 pieces/13" reel	650 pieces/13" reel

Unless Otherwise Specified Dimensions are in Inches /mm ± .010 / .25