



SPRINTMAG® III MAGNETO IGNITION SYSTEM

Mallory's new Magneto Ignition System is designed for Sprint Cars, Modifieds, Supermodifieds, drag racing and any other motorsport that uses a magneto system. Using rare earth magnets, the SPRINTMAG® III delivers higher spark plug current and longer spark duration than other mags. Package includes a highly efficient, oil-filled, external transformer.

SPRINTMAG® III Magneto Ignition System

Chevy V8 265-454 Std Deck	5358514
Chevy V8 w/Pro Cap	5358644
Chevy V8 w/Slip Collar (Gearte)	5358714
Ford V8 351W	5356314
Ford V8 351C 429-460	5354614
Chrysler V8 270-360	5357914

Smaller size fits all injector and air cleaner systems—9" height from engine flange, 3-1/2" diameter

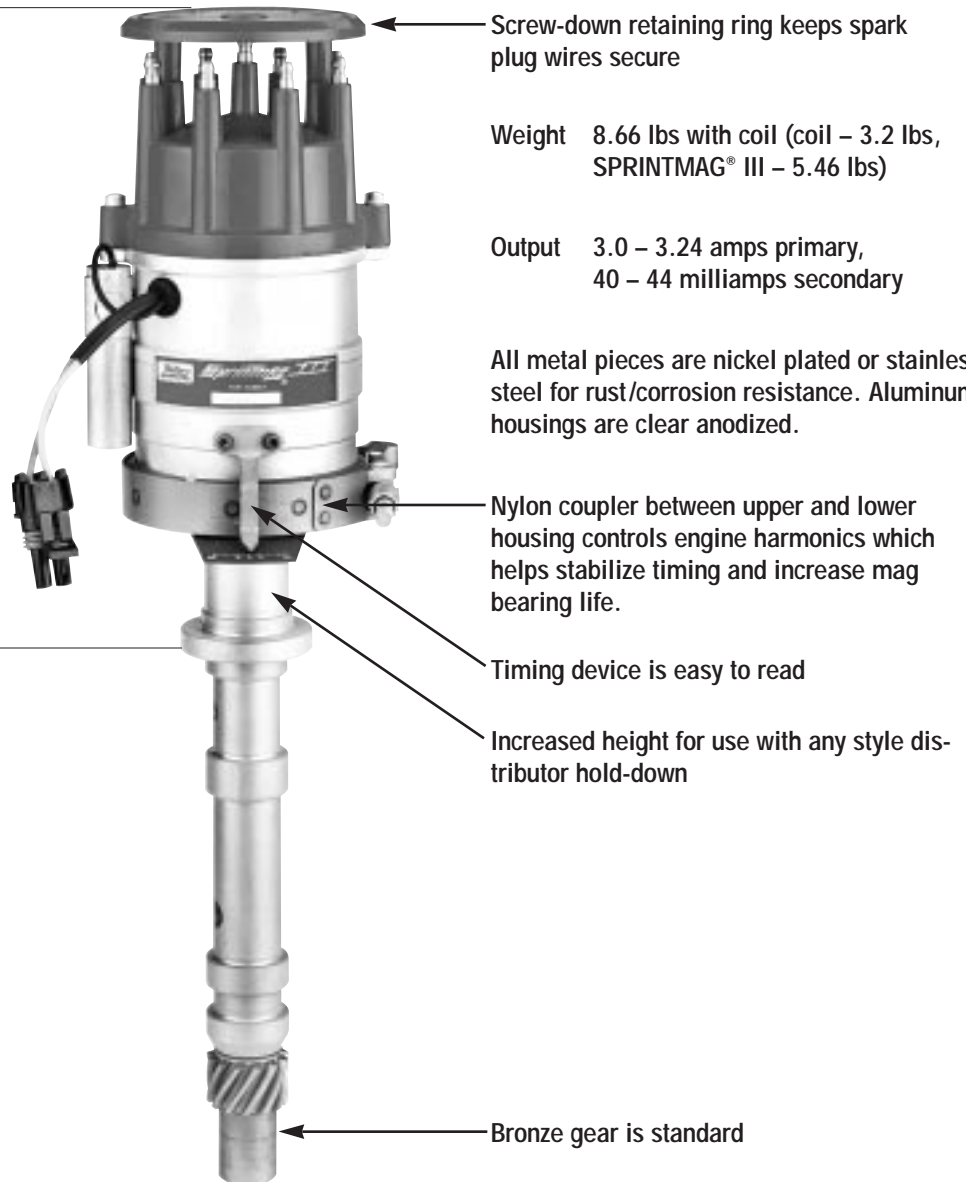

Screw-down retaining ring keeps spark plug wires secure

Weight 8.66 lbs with coil (coil - 3.2 lbs, SPRINTMAG® III - 5.46 lbs)

Output 3.0 - 3.24 amps primary, 40 - 44 milliamps secondary

All metal pieces are nickel plated or stainless steel for rust/corrosion resistance. Aluminum housings are clear anodized.

Nylon coupler between upper and lower housing controls engine harmonics which helps stabilize timing and increase mag bearing life.

Timing device is easy to read

Increased height for use with any style distributor hold-down

Bronze gear is standard



Oil-filled, rubber-mounted mag transformer weighs 3.2 lbs.



Mallory is a division of the Mr. Gasket Performance Group
550 Mallory Way
Carson City, NV 89701
(775) 882-6600